

Installation & Operating Manual

NOTICE: SAVE THESE INSTRUCTIONS

HARMAN®

BUILT TO A STANDARD, NOT A PRICE

Model(s):

Accentra Pellet Insert

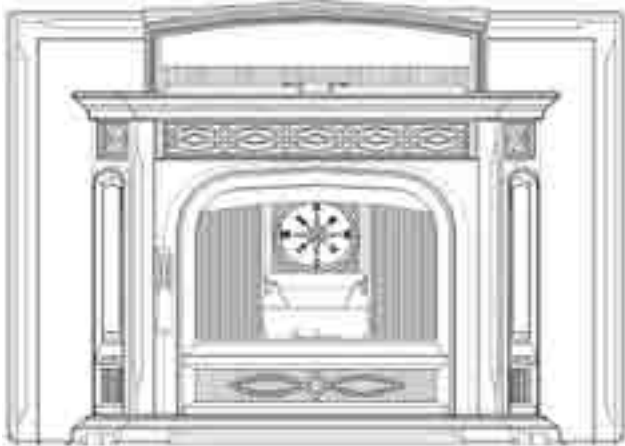

This unit has been retired.
Service parts pages within have
been removed.
For replacement parts, please
refer to the individual service parts
list located on the brand websites.



WARNING



HOT SURFACES!

Glass and other surfaces are hot during operation and cool down.

Hot glass will cause burns.

- Do not touch glass until it is cooled
- NEVER allow children to touch glass
- Keep children away
- CAREFULLY SUPERVISE children in same room as stove.
- Alert children and adults to hazards of high temperatures.

High temperatures may ignite clothing or other flammable materials.

- Keep clothing, furniture, draperies and other flammable materials away.

NOTE

To obtain a French translation of this manual, please contact your dealer or visit www.harmanstoves.com

Pour obtenir une traduction française de ce manuel, s'il vous plaît contacter votre revendeur ou visitez www.harmanstoves.com

Contact your local dealer with questions on installation, operation or service.

This Fireplace insert may be installed into a masonry fireplace, an approved manufactured wood burning fireplace (see page 25), Or, It may be built in to a wall or mantle system when using the optional zero clearance cabinet (see page 26).

SAFETY NOTICE

PLEASE READ THIS ENTIRE MANUAL BEFORE YOU INSTALL AND USE YOUR NEW ROOM HEATER. FAILURE TO FOLLOW INSTRUCTIONS MAY RESULT IN PROPERTY DAMAGE, BODILY INJURY, OR EVEN DEATH.

FOR USE IN THE U.S. AND CANADA. SUITABLE FOR INSTALLATION IN MOBILE HOMES

IF THIS APPLIANCE IS NOT PROPERLY INSTALLED, A HOUSE FIRE MAY RESULT. FOR YOUR SAFETY, FOLLOW INSTALLATION DIRECTIONS. DO NOT USE MAKESHIFT COMPROMISES.

CONTACT LOCAL BUILDING OR FIRE OFFICIALS ABOUT RESTRICTIONS AND INSTALLATION INSPECTION REQUIREMENTS IN YOUR AREA.

CONTACT YOUR LOCAL AUTHORITY (SUCH AS MUNICIPAL BUILDING DEPARTMENT, FIRE DEPARTMENT, FIRE PREVENTION BUREAU, ETC.) TO DETERMINE THE NEED FOR A PERMIT.

CETTE GUIDE D'UTILISATION EST DISPONIBLE EN FRANCAIS. CHEZ VOTRE CONCESSIONNAIRE DE HARMAN.

SAVE THESE INSTRUCTIONS.



Test réalisés par OMNI-Test Laboratories, Inc.
 Report #/Rapport #135-S-12-2, 135-S-12b-6
 Tested to/Testé à: ASTM E1509-04, ULC/ORD-C1482-M1990,
 ULC-S628-93

This pellet burning appliance has been tested and listed for use in
 Manufactured Homes in accordance with
 OAR 814-23-900 through 814-23-909

Normes Européennes:
 NF EN 14785 CETIAT – Déc. 2006
 AEMC MESURES EN 50366 – Déc. 2006
 EMITECH, APAVE & BFP Electronique – Février 2004
 EN 55014-1, EN 55014-2, EN 61000-3-2, EN 61000-3-3

Prevent House Fires

Install and use only in accordance with the manufacturer's installa-
 tion and operation instructions. Contact local building or fire officials
 about restrictions and inspection in your area.

WARNING: FOR MANUFACTURED HOMES: Do not install appli-
 ance in a sleeping room. An outside combustion air inlet must be
 provided. The structural integrity of the manufactured home floor,
 ceiling and walls must be maintained.

Refer to manufacturer's instructions and local codes for precautions
 required for passing chimney through a combustible wall or ceiling.
 Inspect and clean exhaust venting system frequently in accordance
 with manufacturer's instructions.

Use a 3" or 4" diameter type "L" or "PL" venting system, or 4" stain-
 less steel flex as per owner's manual.

Do not connect this unit to a chimney flue servicing another ap-
 pliance.

FOR USE WITH PELLETIZED WOOD FUEL OR UP TO A 50%
 CORN AND PELLETT MIXTURE ONLY.

Input Rating Max: 5 lb. fuel/hr.
 Electrical Rating: 240 VAC, 50 Hz, Start 2.0 AMPS, Run 1.1 AMPS
 US Electrical Rating: 115 VAC, 60 Hz, Start 4.1 AMPS, Run 2.1 AMPS

Emission of CO in Combustion:
 Nominal Heat Output: <.02%. Reduced Heat Output: <.04%
 Flue Gas Temperature: 224 C
 Thermal Output: 10.5kW
 Energy Efficiency: Nominal: 84%, Reduced: 73%
 Route power cord away from unit.

DANGER: Risk of electrical shock. Disconne-
 servicing.
 For further instruction refer to owner's
 Replace glass only with 5mm ceram
 Keep viewing and ash removal dr

MINIMUM CLEARANCE*
 Non-combustible floor
 to the sides and front
 (US).

US Environmen... otecton Agency
 This model is exempt from EPA Certification under 40 CFR 60.531
 by definition (wood heater(A) "Air-to-Fuel Ratio")

Agence Américaine pour la Protection de l'Environnement
 Ce modèle est dispensé par EPA certification d'après
 40 CFR 60.531 par définition
 [Appareil à bois (A) « Ratio air/combustible »]

HARMAN®
 352 Mountain House Road
 Halifax PA 17032 (USA)

DO NOT REMOVE THIS LABEL/NE PAS
 ENLEVER CETTE ÉTIQUETTE
 MADE IN THE USA /FABRIQUÉ AUX USA

Modèle : ACCENTRA INSERT
 Appareil de chauffage à granulés de bois

Serial No. 008
 N° de série:



BARCODE LABEL

PREVENTION DES INCENDIES

Respecter scrupuleusement les instructions du constructeur pour
 l'installation et les consignes de fonctionnement. Respecter les
 règles de sécurité en vigueur dans votre région.

AVERTISSEMENT POUR MOBILE HOMES : Ne pas installer dans
 une chambre. Il est impératif de prévoir une prise d'air extérieur.
 L'intégrité structurale du plancher, du plafond et des murs doit être
 strictement préservée.

Se reporter aux instructions du fabricant et aux réglementations
 spécifiques locales concernant les précautions requises lors de la
 traversée d'un mur ou d'un plafond.

Contrôler et nettoyer fréquemment tout le système d'évacuation des
 fumées conformément aux recommandations du constructeur.

Réaliser l'évacuation des fumées en... les conduits « Spécial
 granulés » de Ø 125 mm ou de... inox double peau
 Ø 125 mm à l'aide d'un adaptat... indiqué dans la
 notice d'utilisation.

Ne pas raccorder ce po... minée déjà utilisé
 pour un autre appareil
 FONCTIONNE EXCI... GRANULES DE BOIS.

Consommation r...
 Caractéristiqu...
 240 VAC - ... narrage 2,0 A

Intensité... 1,1 A
 Tenir l... à l'écart du poêle.
 DA'... cution. Débrancher l'appareil avant toute

... un plus complète, se reporter à la notice

... vitre qu'avec une vitre céramique 5 mm de même
 ... nible auprès de votre revendeur.

... rite frontale et le couvercle de trémie hermétiquement clos
 ... e fonctionnement de l'appareil.
 ... ance calorifique émise: Nominale: 10,5 KW Réduite: 1,8 KW
 ... ncentration CO (à 13 % O2)

... à puissance nominale: < 0,02 % à puissance réduite: < 0,04 %
 Rendement: à puissance nominale: 84 % à puissance réduite: 73%

ECARTS MINIMUM DE SÉCURITÉ
 La protection de sol doit être constituée de matériau
 incombustible et s'étendre de 457 mm (18") à l'avant et
 203 mm (8") sur les côtés (CANADA).

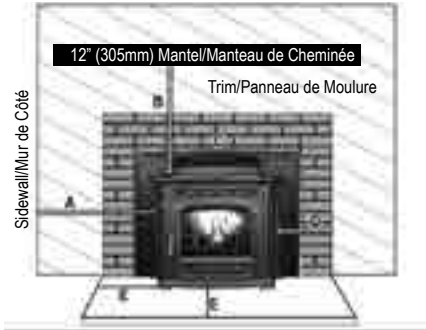

- A. Insert Body to side wall - 10" (254 mm)
- B. Insert Body to 12" (305mm) Mantel/ Manteau de
 Cheminée - 12" (305 mm)
- C. Insert Body to combustible trim above - 3/4" (19 mm)
- D. Insert Body to side trim - 6" (152 mm)
- E. Floor protection. Measured from glass. - 6" (U.S.) -OR
 8" (203mm) to sides and 18" (457mm) in front (CANADA)

Date of Manufacture / Date de fabrication
 2013 2014 2015 JAN FEB MAR APR MAY JUN JUL AUG SEP OCT NOV DEC

PN. 3-90-00676

Manufactured by/Fabriqué par: Hearth and Home Technologies

Rev D IGN

The Accentra Pellet Insert will give you more heat, better temperature control and a level of convenience you won't find in any other pellet burning insert. The Accentra Insert's many outstanding features make it the best value pellet insert on the market today.

The Accentra's versatile design lets you convert a heat wasting fireplace into an efficient heating source. The Accentra Insert could also be a fireplace hearth for your home that doesn't require a chimney. A special zero clearance fireplace kit converts the Accentra insert into a fireplace that can be placed in virtually any corner or against any wall of your home.

The Accentra's on-board microprocessor constantly senses room temperature and automatically makes adjustments in the feed rate and air supply so you get just the right amount of heat 24 hours a day. This remarkable technology lets you fill the hopper, set the desired temperature and walk away. The Accentra insert lights automatically, brings the room up to the exact temperature and will turn off if no heat is required. No other pellet insert offers such accurate and trouble free temperature control. The control technology gives you the widest heat output range of any insert on the market making it an ideal choice to take the chill off in the spring and fall and to heat your home during the coldest months of the winter.

As with all Harman pellet stoves, maintenance is minimal and cleaning is easy. The Accentra Insert lets you burn close to a ton of pellets before ash removal is needed. And what is even better, the Harman Insert Track System lets you slide the insert out of the fireplace so that it can be cleaned or serviced without having to disconnect the venting system. This innovative design is only available on Harman pellet inserts and lets you easily reach key components for cleaning.

Modèle : ACCENTRA INSERT
Appareil de chauffage à granulés de bois

Serial No. / N° de série: **008**

PREVENTION DES INCENDIES
Respecter scrupuleusement les instructions du constructeur pour l'installation et les consignes de fonctionnement. Respecter les règles de sécurité en vigueur dans votre région.

AVERTISSEMENT POUR MOBILE HOMES - Ne pas installer dans une chambre. Il est impératif de prévoir une prise d'air extérieur. L'intégrité structurale du plancher, du plafond et des murs doit être strictement préservée.

PREVENTION DES INCENDIES
Respecter scrupuleusement les instructions du constructeur pour l'installation et les consignes de fonctionnement. Respecter les règles de sécurité en vigueur dans votre région.

AVERTISSEMENT POUR MOBILE HOMES - Ne pas installer dans une chambre. Il est impératif de prévoir une prise d'air extérieur. L'intégrité structurale du plancher, du plafond et des murs doit être strictement préservée.

Se reporter aux instructions du fabricant et aux réglementations spécifiques locales concernant les précautions requises lors de la traversée d'un mur ou d'un plafond.

Contrôler et nettoyer fréquemment tout le système d'évacuation des fumées conformément aux recommandations du constructeur.

Réaliser l'évacuation des fumées en utilisant des conduits « Spécial granulés » de Ø 125 mm ou de la gaine flexible non doublée peu Ø 125 mm à l'aide d'un adaptateur adéquat comme indiqué dans la notice d'utilisation.

Ne pas recouvrir ce poêle à un conduit de cheminée déjà utilisé pour un autre appareil.

FONCTIONNE EXCLUSIVEMENT AVEC DES GRANULES DE BOIS.
Consommation maximum: 2,27 t/gh
Caractéristiques électriques:
240 VAC - 50 Hz - Intensité au démarrage 2,0 A
Intensité fonctionnement normal 1,1 A
Tenir le cordon d'alimentation à l'écart du poêle.
DANGER: Risque d'électrocution. Débrancher l'appareil avant toute intervention.
Pour une information plus complète, se reporter à la notice d'utilisation.

Ne remplacer la vitre qu'avec une vitre céramique 5 mm de même qualité disponible auprès de votre vendeur.
Tenir la porte frontale et la couverture de trémie hermétiquement clos durant le fonctionnement de l'appareil.

Performance calorifique nette: nominale: 10,5 kW Réduite: 1,8 kW
Consommation CO (à 1% O₂)
à puissance nominale: < 0,02% à puissance réduite: < 0,04%
à puissance nominale: 94% à puissance réduite: 73%

ÉCARTS MINIMUM DE SÉCURITÉ
La protection de sol doit être constituée de matériau incombustible et d'épaisseur de 457 mm (18") à l'avant et 203 mm (8") sur les côtés (CANADA).

US Environmental Protection Agency
This model is exempt from EPA Certification under 40 CFR 60.531 (by definition (wood heater(A) (Acid-Fuel Red))
Agence Américaine pour la Protection de l'Environnement
Ce modèle est dispensé par EPA certification d'après 40 CFR 60.531 par définition (Appareil à bois (A) « Ratio air/combustible »)

HARMAN®
352 Mountain House Road
Halifax, PA 17032 (USA)

DO NOT REMOVE THIS LABEL AND ENLEVER CETTE ÉTIQUETTE MADE IN THE USA / FABRIQUÉ AUX USA

Date of Manufacture / Date de fabrication
2013 2014 2015 JAN FEB MAR APR MAY JUN JUL AUG SEP OCT NOV DEC

Manufactured by/Fabrique par: Harman and Home Technologies Rev D 104

Please copy your serial number from the label on your stove to the box below.

SERIAL NUMBER
Hearth & Home Technologies
352 Mountain House Road
Halifax, PA 17032
www.harmanstoves.com

<h2>Table of Contents</h2>	
Automatic Operation	4
Manual Operation	6
ESP Control	8
Assembly & Installation	9
Venting	21
Maintenance	28
Trouble-Shooting	33
Specifications	34
Wiring Diagram	35
Warranty	36
Service Parts List	38
Power Failures / Back-up	44
Fuel Specifications	45
Corn / Pellet Mixture	46

Appliance Certification.

Model: Accentra Insert

Test Lab: Omni-Test Laboratories

Type: Pellet Burning Fireplace Insert / Room Heater

Standard(s): ASTM E1509-04, ULC S628-93 and ULC C1482-M1990. In accordance with OAR 814-23-900 through 814-23-909

Report #: 135-S-12-2

Note: This appliance is also approved for installation into a shop.



Fig. 1

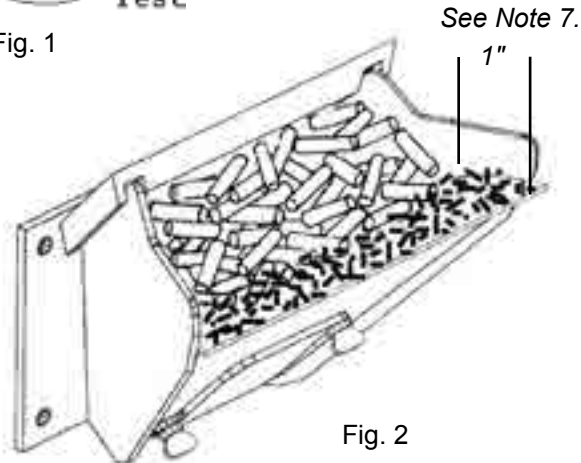

Fig. 2

1. *Fines are small pieces of broken pellets (sawdust). Fines do not flow easily and often build up on the hopper funnel bottom angles. These fines can be pushed into the feeder opening and then fill the hopper with pellets. As the system works, they will be burned.*
2. *The "TEST" cycle will operate the feed motor for exactly one minute. Turning to "TEST" again and again may load too much fuel into the burn pot causing excessive smoke on start-up.*
3. *The firebox low pressure switch will not allow the auger motor or the igniter element to operate if the view door is open.*
4. *Adjust Feed Rate. If this is your first fire or you are trying different pellets, set the feed adjuster to #4, Fig. 1. This is a conservative number and will probably need to be increased. After you know a feed rate setting that works well, use that setting. Remember, if your feed rate is too high you may waste fuel.*
5. *This is usually a weekly maintenance procedure. Cleaning the burn pot with the scraper with a small amount of new fuel in the bottom is not a problem. First, scrape the ashes off the front of the burn pot into the ash pan. Then scrape the holed surface downward into the burn pot. When the stove feeds, these scrapings will be pushed out by the feeder.*
6. *The ash pan can hold the ashes from approximately 1 ton of premium fuel. This means the ashes will only need to be emptied a few times a year.*
7. *Setting the feed adjuster # for maximum burn: With the unit burning in "AUTO", turn to "Stove Mode" and put the fan on "H". Set the Temperature Dial to #7. Allow the unit to burn for about 30 minutes and check ash on front of burn pot. Fig. 2. If the ash line is larger than 1", turn the feed adjuster from #4 to #5. Allow another 30 minutes of burn time and check again. If, at #6 setting, a 1" or less ash bed is not obtainable, it is not a problem. The 1" ash bed is only at maximum burn rate and during normal operation, the ash bed will be larger.*

Starting First Fire

Igniter Switch to "AUTO" (up position)

Make sure the unit is plugged into a properly grounded, 120 VAC, 60 Hz electrical source. The power light should be the only light lit.

Note: Be sure there is no fuel or other combustibles in the ash pan prior to lighting.

1. Turn Mode Selector to "OFF".
2. Fill hopper with pellets.
3. Clean burn pot with scraper, if necessary.
4. If starting after an empty hopper, turn Feed Adjuster to "TEST" (for one 60 second cycle).² This will flow pellets into the auger tube and also allow you to check the motors for operation. **NOTE: The auger motor will not operate with the view door or hopper lid open.**
5. Turn Feed Adjuster to #4.⁴
6. Flip the Igniter Switch up into the "AUTO" position.
7. Turn the Temperature Dial to the desired room temperature.
8. Turn Mode Selector to Room Temperature or Stove Temperature.
9. Fill hopper with pellets and remove ashes as required.

Keep the hopper lid and firebox doors closed while in operation. Maintain door seals in good condition. Failure to do so will affect operation of the appliance and may permit escape of smoke or gases into the living space.

WARNING

BURNING GARBAGE, USE OF IMPROPER FUELS, FIRE STARTERS OR ALTERING THE STOVE FOR HIGHER HEAT OUTPUT MAY CAUSE DAMAGE TO THE STOVE AND COULD RESULT IN A HOUSE FIRE. USE ONLY APPROVED FUELS AND FOLLOW ONLY THESE OPERATION GUIDELINES.

WARNING

NEVER USE GASOLINE, GASOLINE-TYPE LANTERN FUEL, KEROSENE, CHARCOAL LIGHTER FLUID, OR SIMILAR LIQUIDS TO START OR 'FRESHEN UP' A FIRE IN THIS HEATER. KEEP ALL SUCH LIQUIDS WELL AWAY FROM THE HEATER, WHILE IN USE.

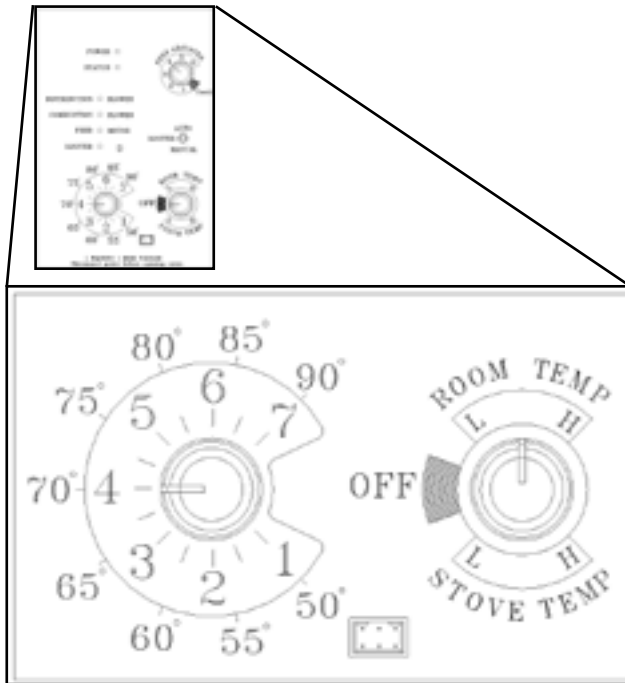

Fig. 3

Room Temperature Mode: This setting will produce a room temperature of 70 degrees with the distribution blower at medium speed.

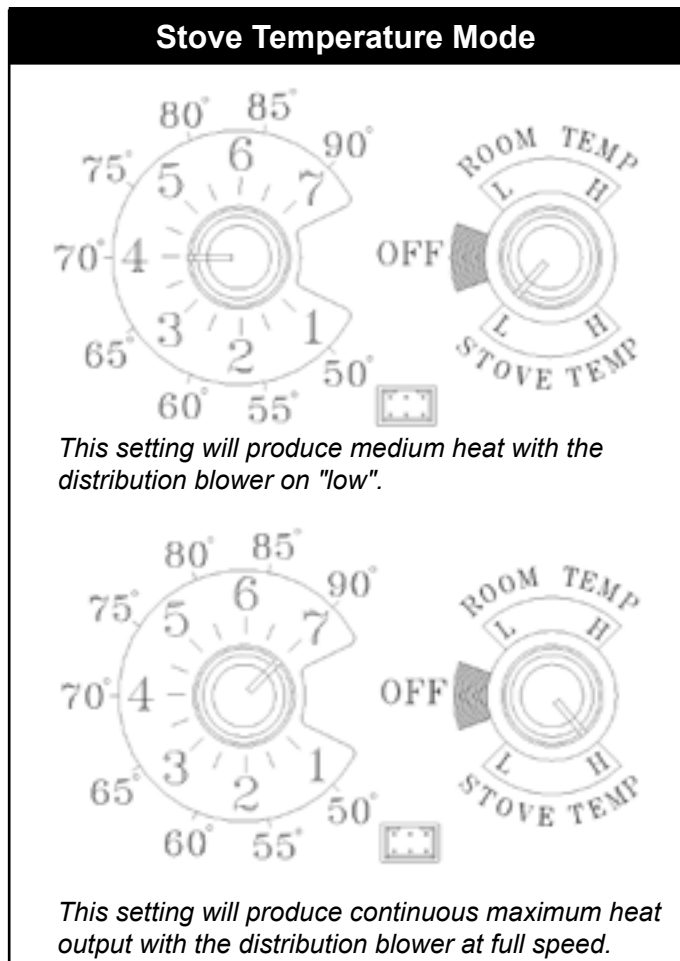

Fig. 4

The Accentra Insert is more than just automatic ignition, it is also automatic temperature control. The automatic system will allow the fire size to be adjusted to match the heating needs and even put the fire out if necessary. If heat is needed after the fire is out, the Accentra Insert will automatically re-ignite and adjust the fire size to match the heating need. The totally automatic room sensor mode is recommended because of its efficiency. The unit can be switched between "AUTO" and "MANUAL" at any time during operation.

Igniter switch to "AUTO"

Room Temperature Mode

In "Room Temp Mode" heat output is controlled automatically by the Room Sensing Probe. When the Room Sensing Probe calls for heat, the stove will increase output. When the Room Sensing Probe is getting close to the set temperature, the stove will begin to level off output and keep the fire burning at just the right temperature to maintain that setting.

High output is determined by the feed rate setting. This setting, generally on #4, can be increased if higher burn rates are necessary (Fig. 1). The unit's maximum burn rate should not create less than 1" of ash on the burn pot front edge(See Fig. 2). Overfeeding is not a safety concern, but fuel may be wasted if unburned pellets fall into the ash pan.

In "Room Temp Mode" a constant fuel consumption rate is sacrificed for exact room temperature. Therefore, as it gets colder more pellets will be burned automatically.

The distribution blower speed will vary according to the position of the mode selector pointer, and fire size.

Igniter switch to "AUTO"

Stove Temperature Mode

This allows for automatic ignition upon start-up only. The unit can then be set at any desired setting. The heat output and fuel consumption will remain constant regardless of room temperature (See Fig 4). The unit's maximum feed rate should not create less than 1" of ash on the burn pot front edge. See Fig 2.

The unit's low burn or maintenance setting is as low as it will go. It will not go out unless it runs out of fuel or is turned off.

Shut-Down Procedure

To kill the fire or stop burning the stove, turn the Mode Selector to "OFF". This will cause the fire to diminish and burn out. When the fire burns out and the stove cools down everything will stop.

If you pull the plug to shut down the stove, all motors will stop. This may cause incomplete combustion and smoke in the firebox. If the load door is opened, the smoke may escape.

The best way to shut down the stove is simply let it run out of pellets, then the stove will shut down automatically.



Fig. 5



Fig. 6

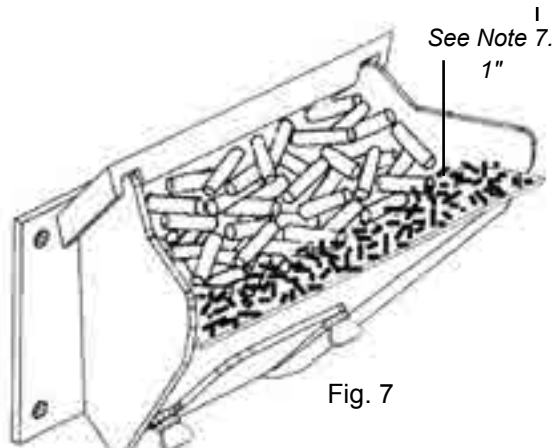

Fig. 7

1. Fines are small pieces of broken pellets (sawdust). Fines do not flow easily and often build up on the hopper funnel bottom angles. These fines can be pushed into the feeder opening and then fill the hopper with pellets. As the system works, they will be burned.
2. The "TEST" cycle will operate the feeder motor for exactly one minute. Turning to "TEST" again and again may load too much fuel into the burn pot causing excessive smoke on start-up.
3. The firebox low pressure switch will not allow the auger motor or the igniter element to operate if the view door or the hopper lid are open.
4. Adjust Feed Rate. If this is your first fire or you are trying different pellets, set the feed adjuster to #4, Fig. 5. This is a conservative number and will probably need to be increased. After you know a feed rate setting that works well, use that setting. Remember, if your feed rate is too high you may waste fuel.
5. This is usually a weekly maintenance procedure. Cleaning the burn pot with the scraper with a small amount of new fuel in the bottom is not a problem. First, scrape the ashes off the front of the burn pot into the ash pan. Then scrape the holed surface downward into the burn pot. When the stove is ignited these scrapings will be pushed out by the feeder.
6. The ash pan can hold the ashes from approximately 1 ton of premium fuel. This means the ashes will only need to be emptied a few times a year.
7. Setting the feed adjuster # for maximum burn: With the unit burning in "AUTO", turn to "Stove Mode" and put the fan on "H". Set the Temperature Dial to #7. Allow the unit to burn for about 30 minutes and check ash on front of burn pot. Fig. 9. If the ash line is larger than 1", turn the feed adjuster from #4 to #5. Allow another 30 minutes of burn time and check again. If , at #6 setting, a 1" or less ash bed is not obtainable, it is not a problem. The 1" ash bed is only at maximum burn rate and during normal operation, the ash bed will be larger.

Starting First Fire

Igniter Switch to "MANUAL" (down position) Make sure the unit is plugged into a 120 VAC, 60 Hz electrical source. The power light should be the only light lit.

NOTE: Be sure there is no fuel or other combustibles in the ash pan prior to lighting.

1. Turn FEED ADJUSTER to desired feed rate. No. 4 is good for most pellets.
2. Turn the MODE SELECTOR to "OFF" and then to the desired mode. This will reset control and start the combustion motor.
3. Turn the TEMPERATURE DIAL to the desired setting.
4. Clean burn pot with scraper if necessary.
5. Fill burn pot with pellets, only level with front edge. (Do Not Over Fill).
6. Add starting gel on top of the pellets. Stir gel into pellets for fast lighting.
7. Light starting gel with a match, and close the door. Operation will begin when the fire reaches the proper temperature.
8. Fill hopper with pellets and remove ashes as required.

Store fuel in a dry area, away from all ignition sources and outside all limits of the stove's clearance requirements to combustibles. Do not store the fuel where it interferes with the refueling of the stove or emptying of ashes. Do not store any ashes removed from the stove near the fuel or other combustible materials.

WARNING

BURNING GARBAGE, USE OF IMPROPER FUELS, FIRE STARTERS OR ALTERING THE STOVE FOR HIGHER HEAT OUTPUT MAY CAUSE DAMAGE TO THE STOVE AND COULD RESULT IN A HOUSE FIRE. USE ONLY APPROVED FUELS AND FOLLOW ONLY THESE OPERATION GUIDELINES.

WARNING

NEVER USE GASOLINE, GASOLINE-TYPE LANTERN FUEL, KEROSENE, CHARCOAL LIGHTER FLUID, OR SIMILAR LIQUIDS TO START OR 'FRESHEN UP' A FIRE IN THIS HEATER. KEEP ALL SUCH LIQUIDS WELL AWAY FROM THE HEATER WHILE IN USE.

The Accentra Insert is capable of manual operation. This also allows the operator to manually control operation during an emergency (i.e. igniter failure, when using a 502H battery backup, or when using certain generators.)

The unit can be switched between "AUTO" and "MANUAL" at any time during operation.

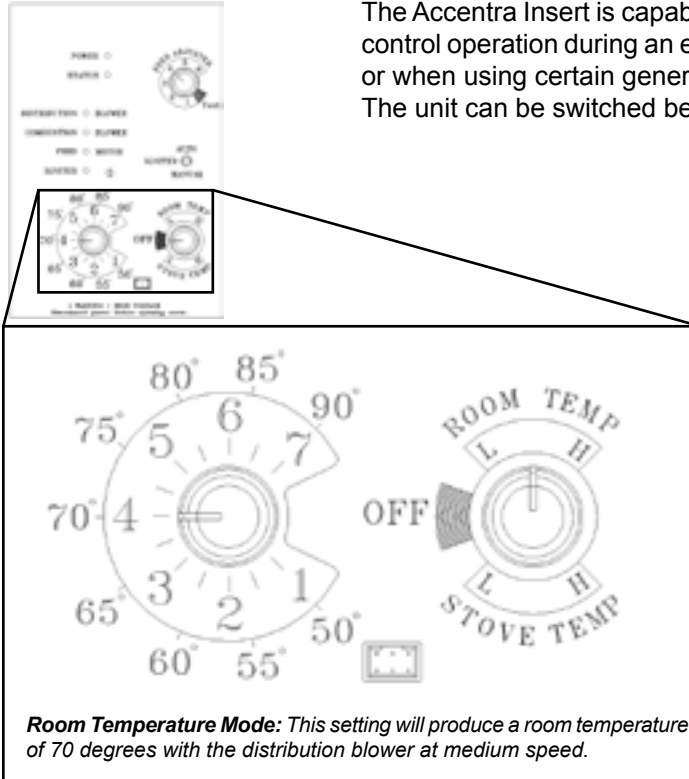

Fig. 8

NOTE: When starting the unit in the "AUTO" mode and switching to "MANUAL", you may switch at any time. Once an ignition cycle is started, it will continue regardless of mode.

Igniter Switch to "MANUAL"

Room Temperature Mode

The fire will have to be lit with starting gel and a match, or started automatically, see "Automatic Operation". Turn to "Manual" position once the start cycle begins.

The difference between "AUTO" Room Temperature Mode and "Manual" Room Temperature Mode is that the fire will not go out as the room temperature goes above the control board setting. The unit can only go to low burn and will remain there until it runs out of fuel or until more heat is needed and the feed rate increases. Feed rate adjustments and dial settings are the same as "AUTO" settings.

Igniter Switch to "MANUAL"

Stove Temperature Mode

The advantage of this mode is to allow the operator to have a large viewing fire without blowing extra heat into the room.

During operation, with the temperature dial set at #4 or less, the distribution fan will not operate. A #4 on the temperature dial and a #4 on the feed adjuster is approximately 80% output. It is not necessary to operate the distribution blower below this point. Therefore, there can be a higher feed rate (a larger viewing fire) without an excess of hot air blowing into the room.

An example of when to use the Manual Stove Temperature Mode is if you want to watch a large fire and the room is already up to temperature. The Stove Temperature Mode allows you to have a larger fire and a lower sound level, without the distribution blower.

NOTE: During the use of this mode, if you keep increasing the temperature dial setting to increase the fire size, the distribution blower will automatically come on when the ESP Temperature reaches 350° F, or 81% output.

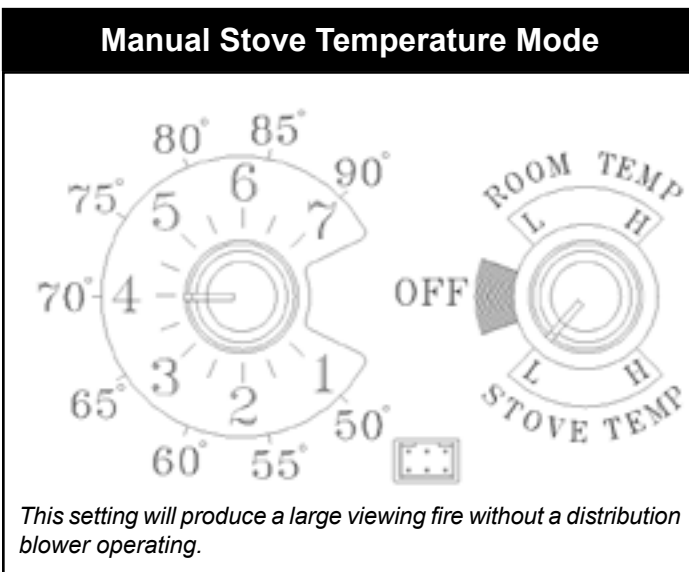

Fig. 9

Power Light

Indicates power to the control.

Status Light

Will be lit in either stove or room temp mode when pointer is not within off position band except after normal shut down. Blinks to indicate errors listed below.

Indicates power to distribution blower.

Indicates power to combustion blower

Indicates power to the feed motor.

Indicates igniter is on.

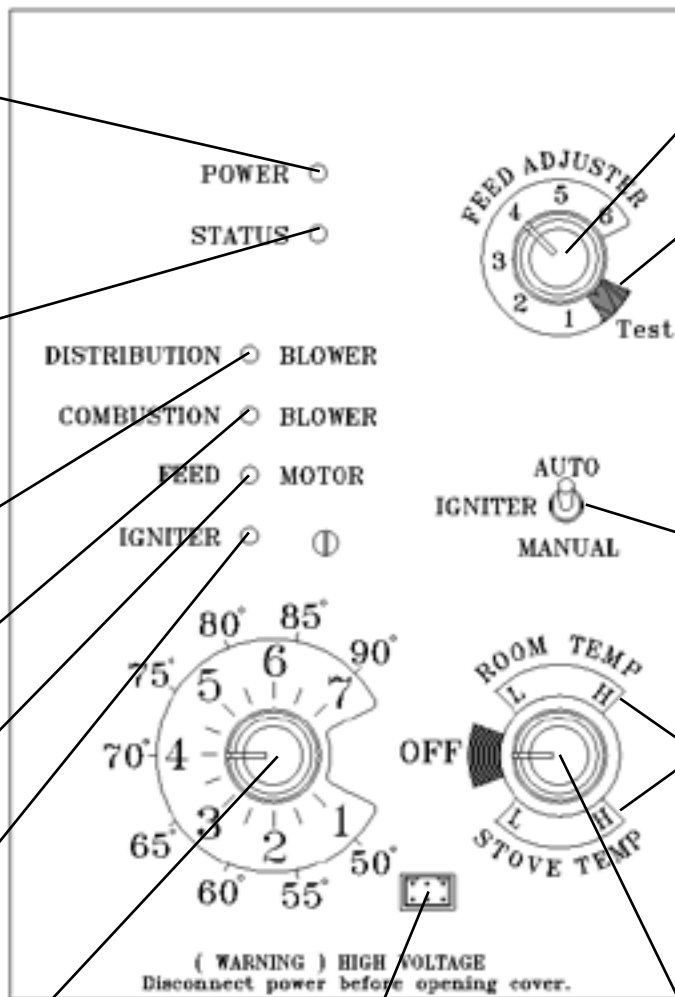

Feed adjuster

Sets the maximum feed rate

Test

Runs all motors at full speed for one minute to check operation. Afterwards the control will simulate a minimum burn with the combustion blower remaining on low.

Igniter switch

Set to appropriate Start-Up mode.

Distribution Blower speed adjustment range.

L = low
H = high
Variable speed anywhere between L and H; although as the stove temp. goes up, so does the L and H scale.

Temp dial

Allows you to adjust the room temperature setting, in Room Temp Mode, using the outer scale marked in degrees Fahrenheit. It also allows you to adjust the stove temperature setting, while in Stove Temp Mode, using the inner scale marked from 1 to 7.

Dealer Diagnostic Port

For dealer maintenance only. Requires special DDM monitor supplied to Harman Dealers exclusively.

Mode Selector

Allows you to choose between Room Temp Mode, Stove Temp Mode, or OFF. Also allows you to vary the distribution blower speed by turning the knob to the high or low side of each mode.

Status light error messages:

3 Blinks: Indicates that the ESP (Exhaust Sensing Probe) has failed, has a broken connection, or has gone out of range too many times. This requires a manual reset*.

4 Blinks: Can occur only in Room Temp Mode and indicates Room Sensing Probe failed or not installed. If a Room Sensing Probe is then installed, the status light will automatically reset.

NOTE: Unit will not start in "AUTO" with this status error.

5 Blinks (In Igniter Auto. Mode Only): Indicates that the unit has failed to light within the 36 minute start cycle. To reset - Turn Mode Selector to "OFF", then turn to either mode again.)

6 Blinks : Indicates that the control has calculated poor or incomplete combustion occurring for more than 25 minutes.

A six blink status may be set if the stove is allowed to run out of pellets. To reset, turn mode selector to "OFF" then back on to the desired mode. If the unit was not out of pellets, see Troubleshooting section, Page 33, for more details.

* **Manual reset**- disconnect power cord for a few seconds and reconnect. If error still occurs call your Dealer.

How to Reduce the Weight for Installation

1. Remove the top/lid assembly and side panels.

Note: Removal of the cast hopper lid itself is NOT necessary or recommended.

Note: The hopper lid must be in the "OPEN" position before the top/lid assembly can be lifted off or reinstalled on the stove body.

There are (4) 1/4-20 x 1/2" flange head bolts securing the top/lid assembly to the stove body. They can be removed from the underside with a 3/8" socket.

The cast top and lid assembly bolt down bars:

On each side of the stove body, underneath the cast top, are (2) 1/4" flange head bolts. See Fig. 12.

These bolts pull the cast top and lid assembly down onto the hopper gasket to seal the hopper.

They also allow for a small amount of front to back adjustment for alignment of the top into the wing pockets.

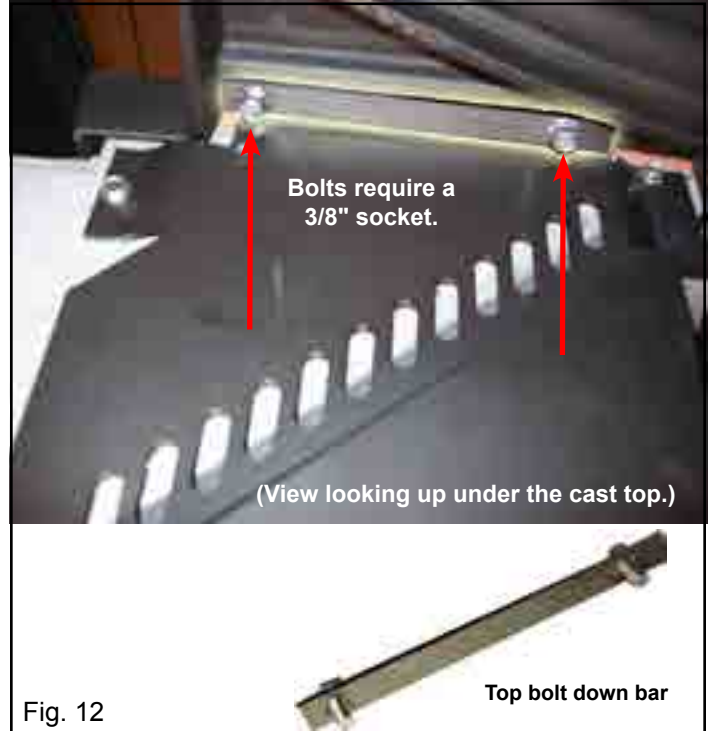
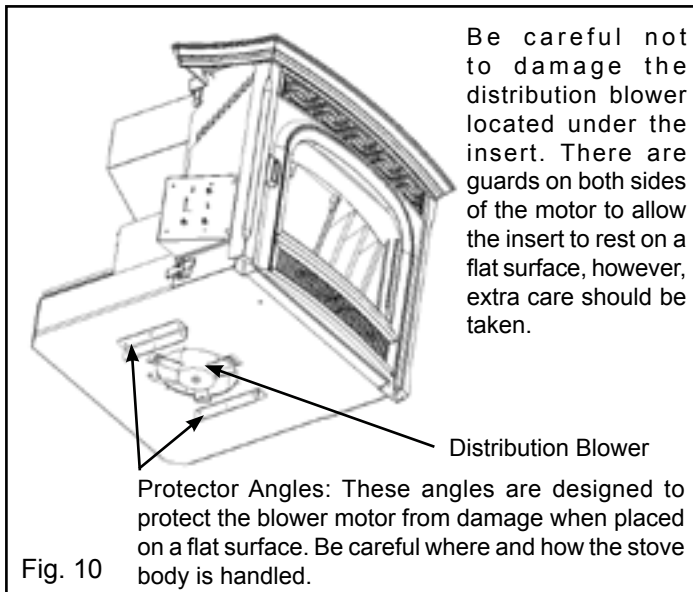

NOTICE: When removing the top and lid assembly, first remove the hopper lid position switch from its mounting bracket. Loosen the switch retainer nut, and allow the switch to drop out of the bracket. **Leave the bracket in place.**

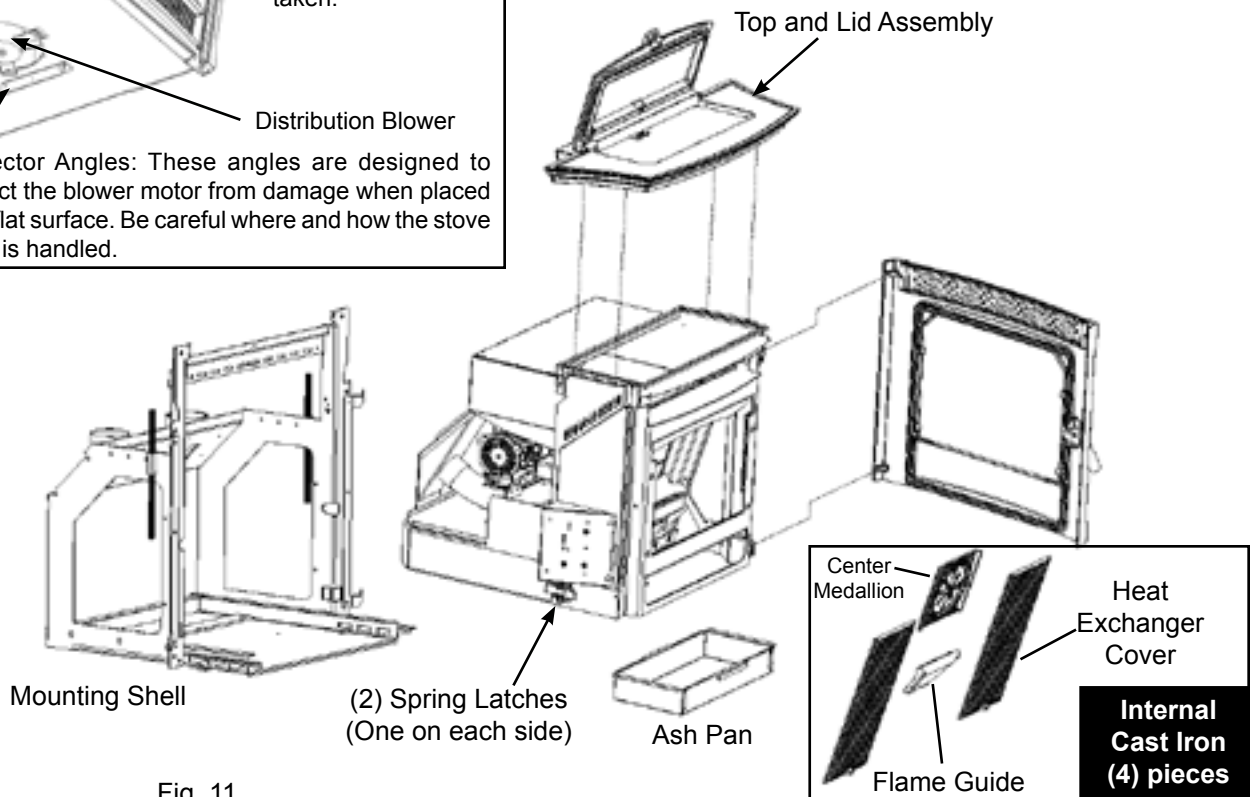



Fig. 13

Lasered hinge pin pivoting point

Up and down clearance adjustment slots.

Cast side panel hinge

Remove the cast side panels by lifting them upward off of the hinge pins. See Fig. 13.

How to Reduce the Weight for Installation, cont'd

2. Remove the door by swinging it open approximately 90° and lift it upward until it clears the hinge pins.
3. Remove the ash pan
4. Remove the (4) internal pieces of cast iron. See Fig. 14 and 15.

Removing the Center Medallion

- Lift up on the 2 bottom corners of the medallion until it is higher than the top of the flame guide. Fig. 14
- Pull the bottom edge of the medallion front approximately 1 inch.
- Pull downward on the corners of the medallion until the top is released from the 2 retainers that keep the top aligned when in place.

Note: The heat exchanger covers will tilt to the front when the center medallion is removed.

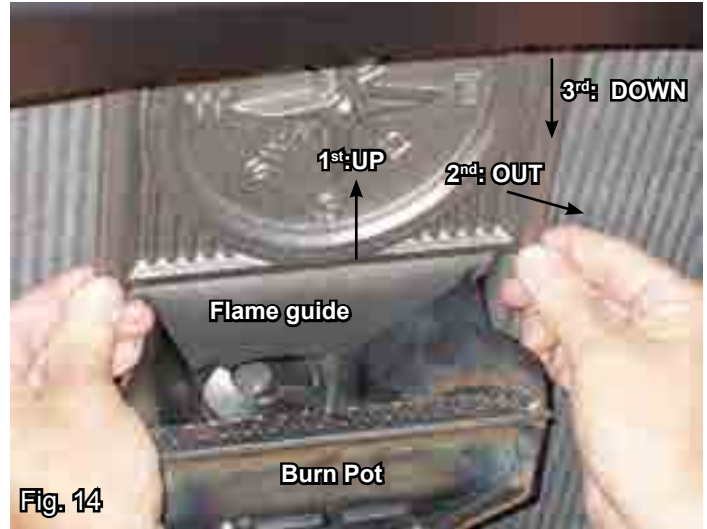

Fig. 14

Removing the Heat Exchanger Covers

- Remove the heat exchanger cover by lifting it upward about 1/2 inch and move the bottom edge front until it sits flat on the firebox bottom.
- Rotate the edge of the heat exchanger closest to the burnpot until it is in front of the burnpot.
- Tip the top of the heat exchanger toward the middle of the opening until it can be lifted up and out.

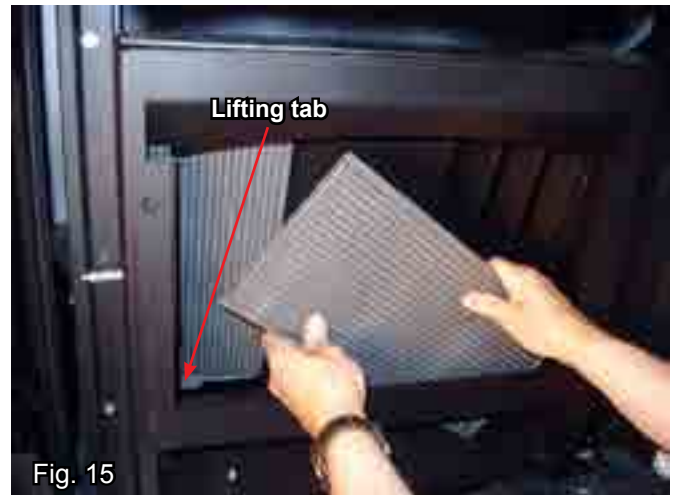

Fig. 15

Beginning Installation

IMPORTANT: The mounting frame/surround assembly and flue piping is the most critical part of the installation and must be done correctly and installed **securely**.

1. Choose the chimney configuration that is best suited for the installation. See venting section. Page 21

Note: If 100% outside air is desired or required, the outside air option will need to be installed on the stove's body. (See instructions included with outside air kit (part #1-00-674080.) See Page 22.

2. Make sure the unit will fit into the fireplace opening. When installing in smaller fireplaces, test fit the mounting frame into the firebox. Note: The unit overhangs to the rear. See Fig. 17

3. **Installing the 3 piece cast surround:** Install the left and right cast sides to the mounting frame using the 1/4-20 x 3/8 bolts supplied. Install (4) 1/4-20 x 3/4" set screws into the top wing. Then install the top wing onto the frame using the (4) 1/4-20 nuts. The left and right side should be done before the center section is installed. Make sure the bolts are loose. Do not remove the side panel hinges. The left and right side wings should be standing up aligned with the side of the mounting frame and slid inward towards the center. Note: The wings mount on the rear side below the notch and on the front side above the notch. See Fig. 16 & 18. Slide the cast ash lip onto the frame and check to make sure it can go against the roped frame rails and fits into the pockets on the left and right cast sides. See Fig. 19.

Install the center section.

4. If the wing extension is required, it should be installed next.

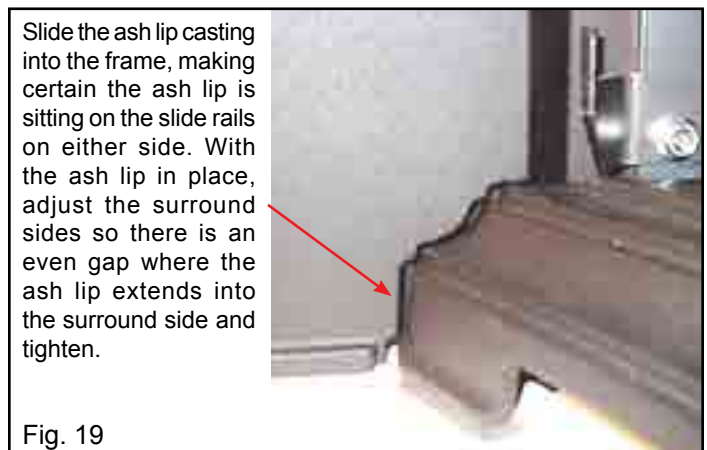
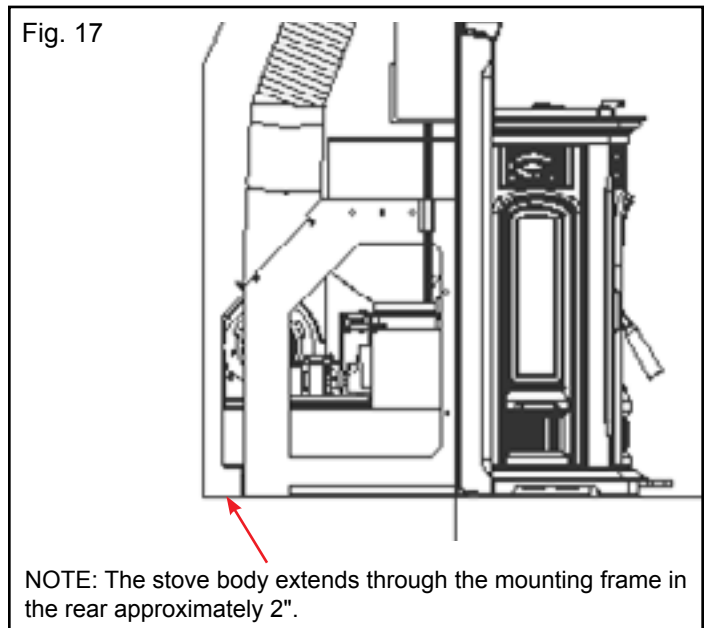
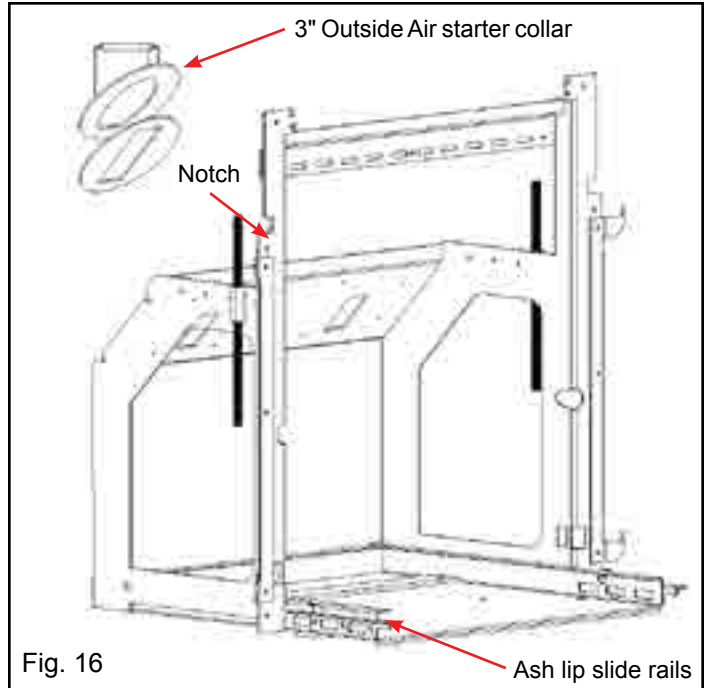
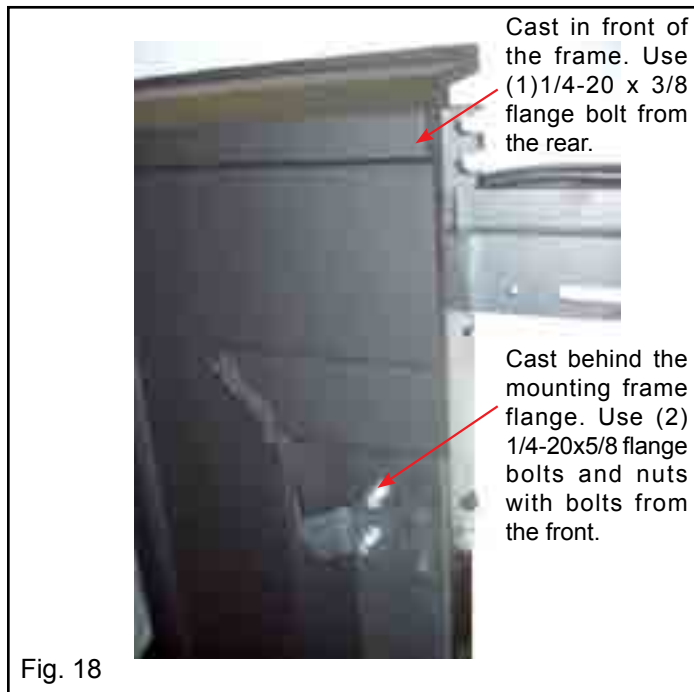

Optional Wing Extension

The optional wing extension is made for fireplace openings which are larger than the cast wing. The standard wing extension is 48" wide by 34" high.

Custom sized wing extensions can be purchased from your dealer, for any fireplace openings larger than the standard wing extension area.

These optional wing extensions will have a 1/2 inch return bend as shown in fig. 20. Custom oversized wing extensions with a radius top can be ordered with a radius of your choosing. These radius wing extensions WILL NOT have a return bend, although they will be made of thicker metal to reduce warpage.



Fig. 20

5. The power cord can be installed exiting the left (standard) or right side of the surround. If a right side cord is desired, follow the instructions below.

Changing the cord exit location from the left side to the right side:

The cord is located on the left side, standard from Harman. (See fig 21.)

To route the cord to the right side:

Cut the wire-ties looping the cord to the left

Re-route the cord along the top of the steel angle and down the right side.

Re-tie (not supplied by Harman) the wire through the notches provided in the mounting frame. Then down the right side rail.

Do not remove or move the cord retainer, it is made to reach both the right and left sides.

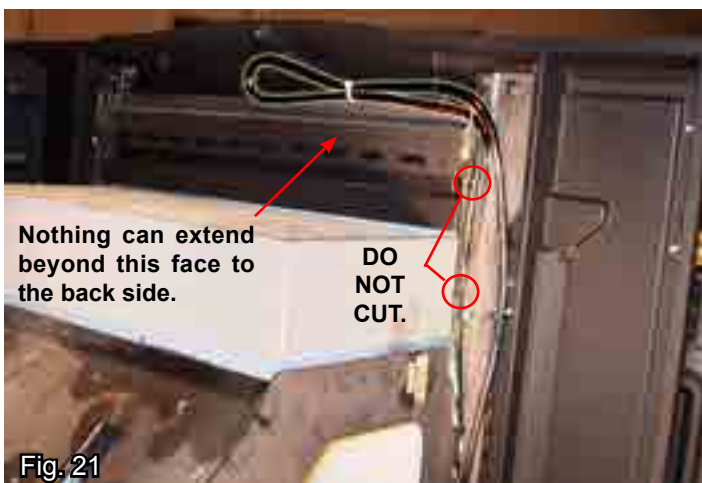

Fig. 21

Connecting the cord retainer to the wing

With the three wing pieces completed, the cord retainer must be bolted to the bottom rear of the wing. Either left exit (shown in fig. 22) or right exit.

At the bottom rear edge of the right and left wing there is a small radius indent for the cord to exit between the wing and the fireplace face.

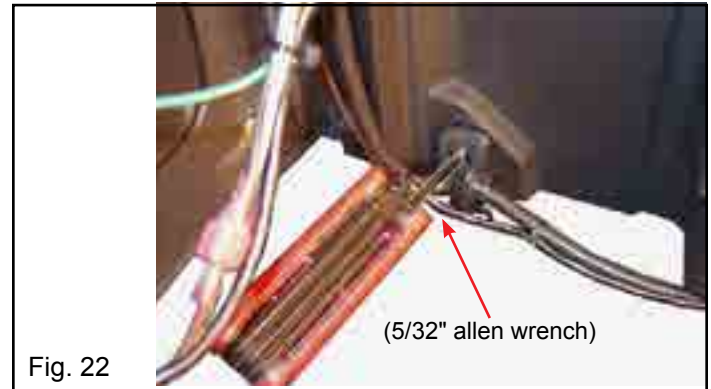

Fig. 22

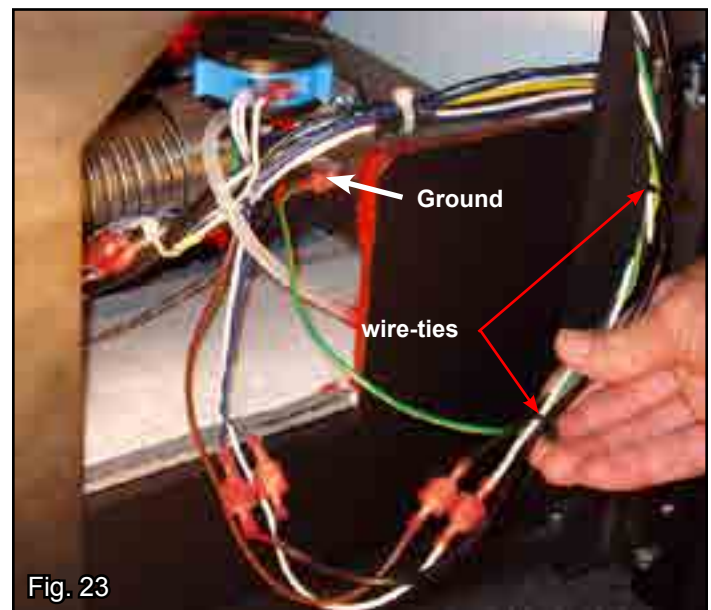

Fig. 23

6. You must now decide whether to install the room sensor as a wall sensor or as a return air sensor. Harman highly recommends that the room sensor be installed. If you are installing the room sensor as a wall sensor, the long black 2 wire cable must be wire-tied to the power cord. This wire is long enough to reach the end of the power cord so the installer can reach past the hearth to the location where the extension wire (18/2 thermostat wire, not supplied by Harman) can be spliced to go to the wall location chosen for the room sensor.

7. If the room sensor is used as a return air sensor rather than a room thermostat/sensor, the black cable will not be used. The room sensor itself (gray or black cable with black and red wires) will be connected to the blue twisted wires from the control board.

Note: The stove body must be able to slide out of the shell to the limit of the power cord wires for cleaning and service. Therefore, if the room sensor is connected as a return air sensor, the wire should be connected long enough to allow this, but not too long that it would get tangled or pinched anywhere.

Notice: The male/female connections between the mounting shell and the stove body should always be maintained. Wirenut or taped splices should never be used.

Connecting the room sensor as a return air sensor

Insert the sensor end of the wire from the rear of the mounting frame through the hole as shown in fig. 24 .

Wire-tie the sensor end so that the sensing tip is in the middle of the front return air opening. See Fig. 25.

Wire-tie the sensor wire to the inside of the mounting frame up to the cord grounding location. Follow the power wiring to where you make the male/female terminal connection to the twisted blue wires.

There are (2) crimp-on connectors in the hardware pack that must be installed on the internal ends of the room sensor wires.



Fig. 24



Fig. 25

Side Return Air Holes

8. Install the (4) 3/8-16 x 1" leveling bolts into the threaded holes in the bottom pan of the mounting shell. The front two leveling bolts may not be necessary, but the back two will need to be used to level the wing so that it is flush with the fireplace face. See Fig. 26

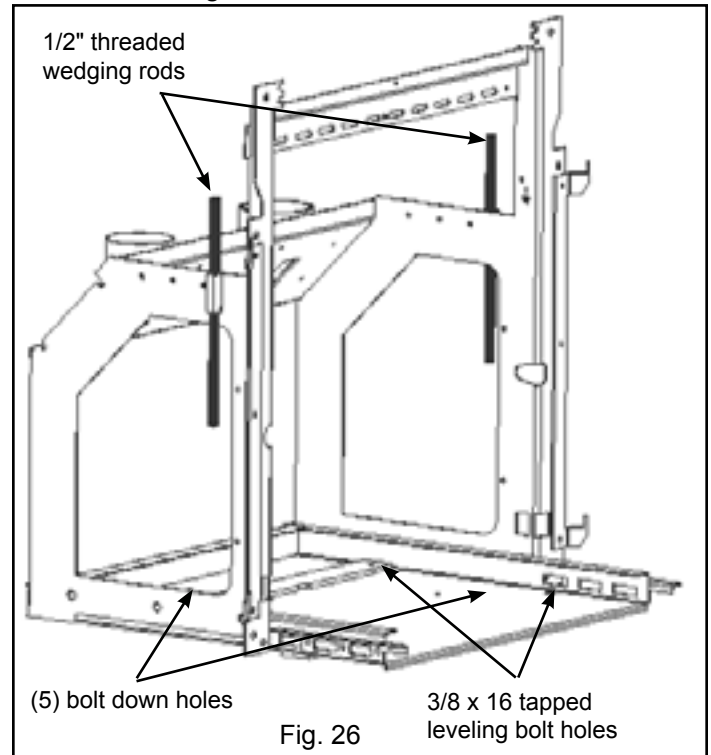

9. Install the completed frame/surround assembly into the firebox and level/plumb the wing to the fireplace face using the leveling bolts as jacks.

If needed, the installed HCS 1/4-20 x 1 Z5 bolt can be used to adjust the squareness of the stove body in the cage.

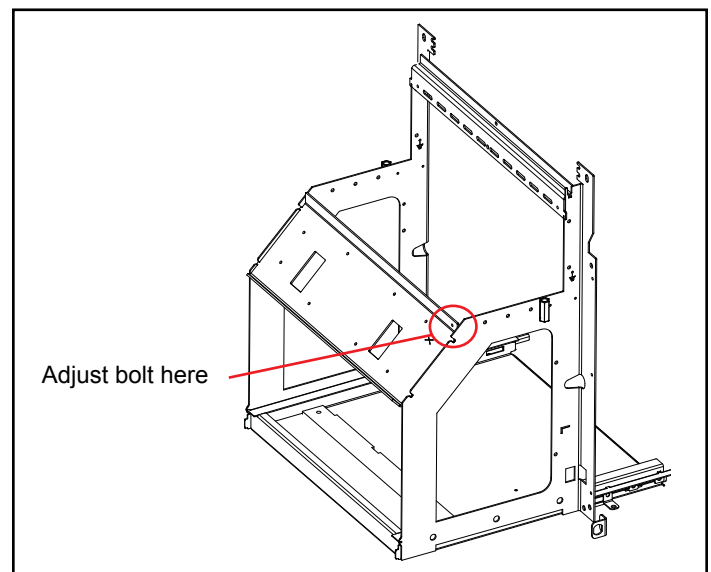

* Floor protection must be used from hearth opening to 6" (152mm) in front of door glass and 6" (152mm) to each side of the stove body to protect combustibles from hot ashes. A minimum size will be 16.5" deep by 30" wide and be made of a non-combustible material or meet UL approval.

- A = to sidewall
- B = to 12" mantel
- C = to 3/4" trim
- D = to 3/4" trim
- E = floor protection

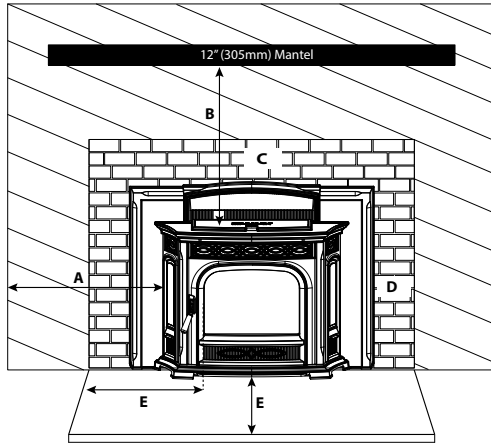

CLEARANCES:	A	B	C	D	E
From Insert Body:	10"	12"	0"*	6"	6" (From Glass)

*3/4" trim, zero clearance to cast surround

10. Test fit the cast ash lip (See fig. 25) on the shell frame mounting rails. The ash lip should slide on these side rails without lifting upward off of the rails as the ash lip is slid inward. A small clearance of about 1/16" is an ideal space between the legs of the ash lip and the hearth. This cast ash lip is a decorative part that does not and should not support any weight.
 11. Tighten the (2) 1/2" threaded rods up against the lintel of the fireplace opening. It is also recommended to use some form of anchoring screws through the bottom of the shell into the hearth. There are up to 5 holes provided. Note: It is a good idea to check the ash lip again. The frame may have shifted when the final anchoring was completed. See fig. 26.
 12. Complete the flue piping, and outside air piping, if used. Make sure the damper area is sealed.
- WARNING! DO NOT CONNECT THIS UNIT TO ANY AIR DISTRIBUTION DUCT OR SYSTEM.**
13. If a rear exit flue configuration is used, with or without outside air, make sure the flue pipe termination clearances are followed as per the manufacturers recommendations.

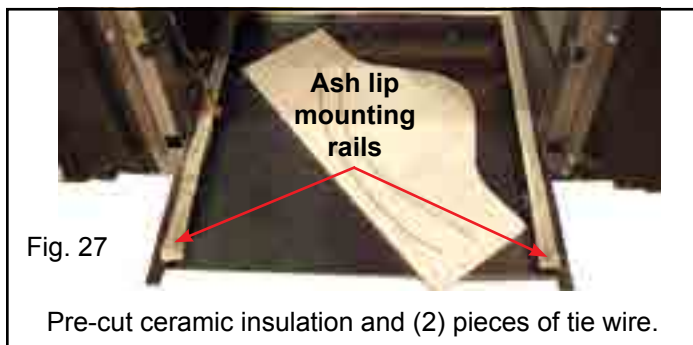

Fig. 27



Flue Pipe Stub Assembly

There are three different flue pipe stubs available.

1. The unit comes standard with the largest, for use with 4" stainless steel flex pipe.
2. Part #1-00-674040 is for use with 4" PL vent starter pipe.
3. Part # 1-00-674039 is for use with 3" PL vent starter pipe and also for use with 3" aluminum flex duct for outside air connections.

The flue stub assembly base is a round plate which allows it to swivel to allow the flue pipe to exit the mounting frame in other positions rather than straight up. See fig. 28.

14. Install the flue pipe insulation wrap. See Fig. 27. This ceramic insulation is precut to form around the flue pipe stub, to reduce heat transfer into the area around the rear of the hopper and motor area. **This insulation must be installed in all configurations, even if a rear discharge is used.** See Fig. 29.

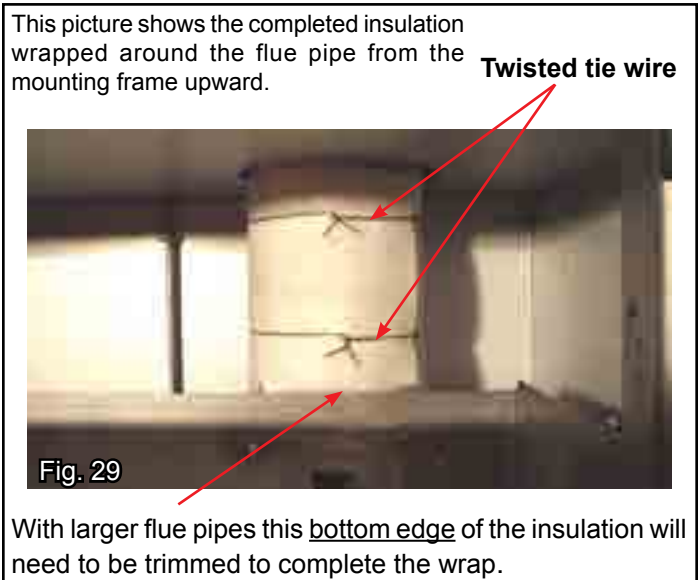

With larger flue pipes this bottom edge of the insulation will need to be trimmed to complete the wrap.

15. Install the cast side panels by sliding them down over the lasered hinge pin. Note: Check for rotational swing, but finish with them in the open position. The cast side panels may need adjustment after the stove body is latched into place and the front door is closed.

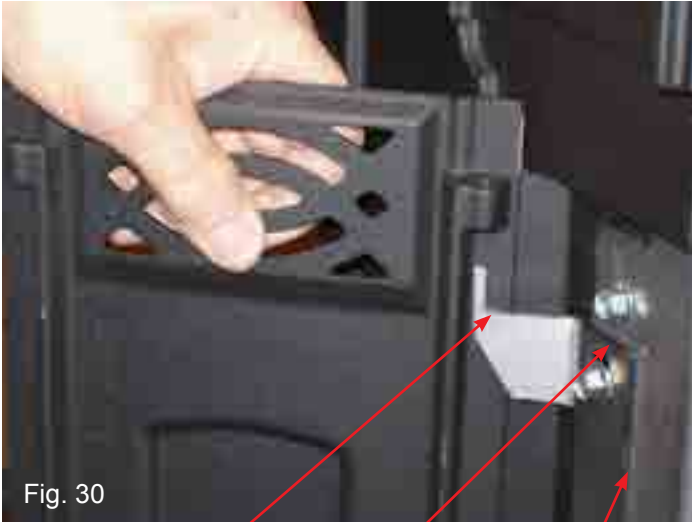

Fig. 30

Lasered hinge pin pivoting point
 Up and down clearance adjustment slots.
 Cast side panel hinge

16. Place the stove body on the mounting shell gasketed rails and insert the body into the opening far enough that it can't tip out. Note: A service rail kit (Part #1-00-08007), or a pair of 2 x 4's supported in front of the hearth will make this job easier. See Fig. 31.
17. Complete the following electrical connections (CAUTION: Disconnect the power cord.) There are 5 connections that must be completed. See Fig. 33 & 34.

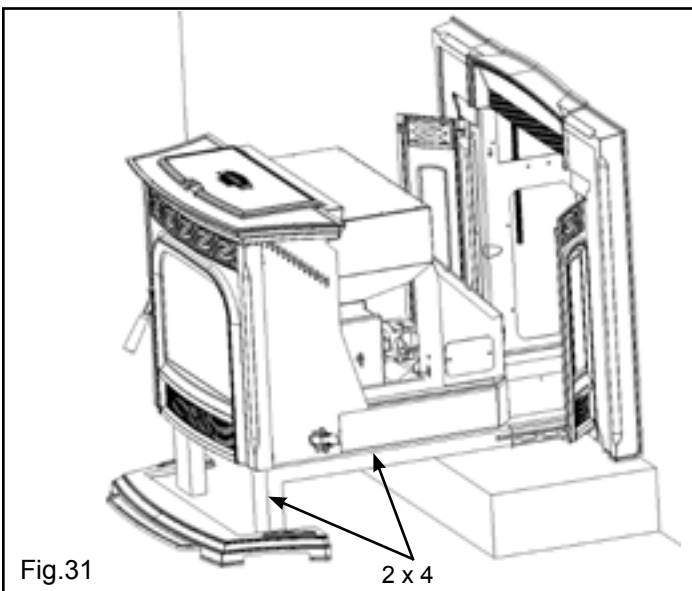

Fig.31

2 x 4

Connecting the ground from the wing to the stove body

The green wire with a female terminal is the stove body ground. See Fig. 32

On the combustion air inlet box there is a male terminal ground.

If service is performed on this stove, this ground connection must be the first one on and the last one off.

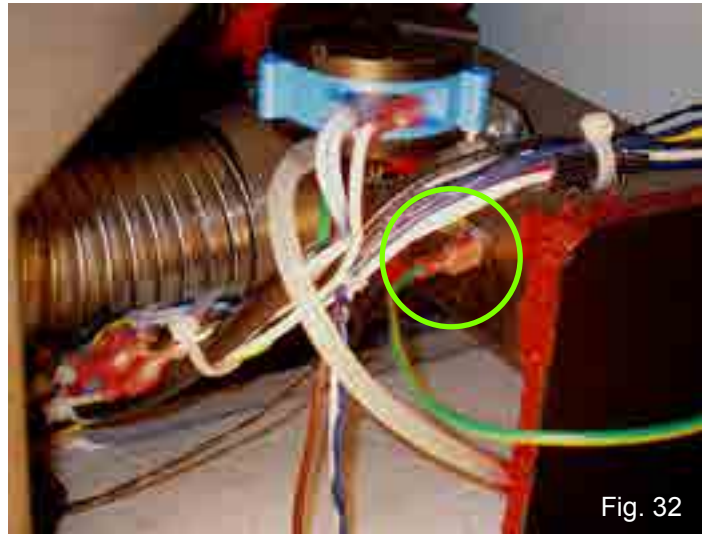

Fig. 32

Connecting the power cord

The white from the mounting frame connects to the white of the insert body. The black from the mounting frame connects to the brown of the insert body.

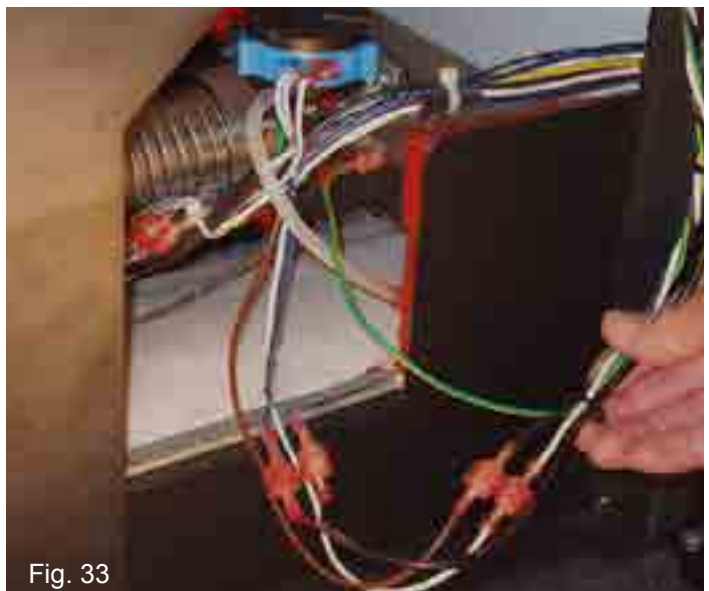

Fig. 33

Connecting the Room Sensor

- Connecting the room sensor to the blue twisted wires from the control board:
- (2) 3/16 inch male terminals are provided for the ends of the room sensor wires.
- They will mate with the female terminals on the blue twisted wires.
- These connections are “not polarity specific.”

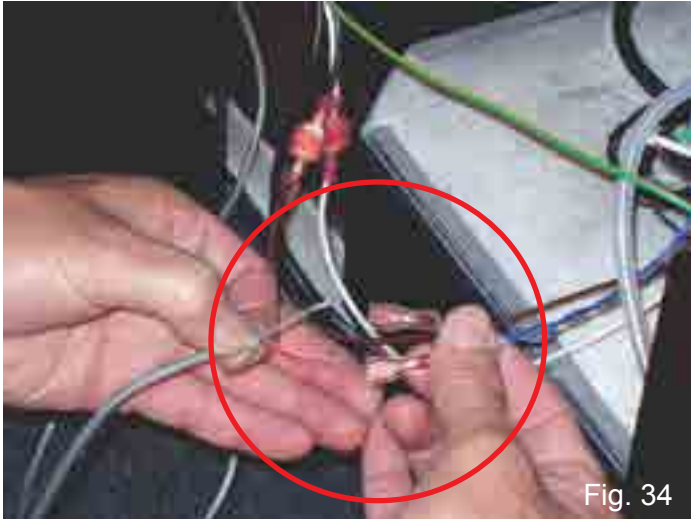

Fig. 34

18. Install the front door. Check the latch and gasketing.

Hopper Seal

- Inspect the silicone sponge hopper to top seal gasket.
- Look for tears or areas where the gasket may not seal properly to the bottom of the cast top. This only needs to be done when the top is removed. This is NOT necessary if the cast top is not removed. (Not part of any monthly, semi-annual or annual maintenance.)



19. Inspect the silicone sponge gasket on the top edge of the hopper.
 - If it is okay, put the cast top/hopper lid assembly (see Fig. 35) into place over the hopper.
 - Make sure the hopper lid is open to install the top, then close it to keep from getting pinched in case the lid falls unexpectedly.
 - Insert the (4) 1/4-20 x 1/2 flange head bolts into the mounting hole but do not tighten them. See page 9, fig. 12.

20. "Test" the unit with the stove body pulled out. This will allow you to see the motors in operation.
 - Turn the control to the "OFF" position.
 - Plug the unit into a 120 VAC, 60 Hz outlet.
 - Turn the control to "test". All of the motors should operate at full voltage for 60 seconds.

Note: The door must be closed for the feed motor to operate.

- With the "Test" completed, turn the feed adjuster off of test, and unplug the unit.

21. Inspect the flue docking gasket. See Fig. 36.

Docking Gasket

Every time the unit is pulled out of the mounting frame, the orange high temperature docking gasket should be inspected. Check for tears or signs that the gasket is not sealing properly.



Fig. 36

22. Slide the stove body into the mounting frame.

- Note: The two spring latches on the bottom right and left side of the body must be in the proper position to enter the latch holes. (See fig. 37).
- Latch the (2) spring latches into place.

23. Shift the cast top/hopper lid assembly inward as far as possible to achieve a parallel fit with the surround sides. See Fig. 39. Tighten the cast top/hopper lid assembly bolts with a 3/8" socket. See page 9, Fig. 12.

24. Install and adjust the side panel magnets.

- In the hardware pack are (2) magnets, (2) spacers and (2) 10-32 x 1 1/4" bolts and nuts.
- Bolt the magnets through the holes provided in the cast ash lip.

Important: The spacer must be on top of the hole, the magnet on top of the spacer, with the bolt going, down, through the hole, with the nut at the bottom, under the ash lip. See fig. 38.

25. Check the fit of the cast ash lip to make sure that it can be slid in and out easily. The cast ash lip can remain in place at this time. Note: The cast side panel hinges can be moved upward if necessary to gain clearance for the cast ash lip.

Cast Side Panel Installation

- The stove body must be pulled out of the mounting frame several inches to install the cast side panels.
- Slide the cast side panel down over the hinge pins.
- Slide the stove body in and latch into place.

Note: The cast side panels must be left in the open position to allow access to the latches.

- Slide the ash lip into place. (This would be inward until the rear of the cast iron touches the mounting frame front.)
- Close the cast side panels.
- Check the gap alignment and the top and bottom gap spacing.
- The top and bottom spacing can be adjusted by loosening the 3 bolts and sliding the hinge up or down until the spacing suits.
- With the front door closed and latched, check the vertical space alignment. The only method of changing or adjusting this gap is by bending (slightly) the hinge angle. See fig. 39.
- Due to the use of all cast iron parts, some small amounts of misalignment are expected. Since some parts are angled and some have rounded edges, this misalignment is very seldom noticeable.
- It is very important that the cast side panels open and close freely for control board access.

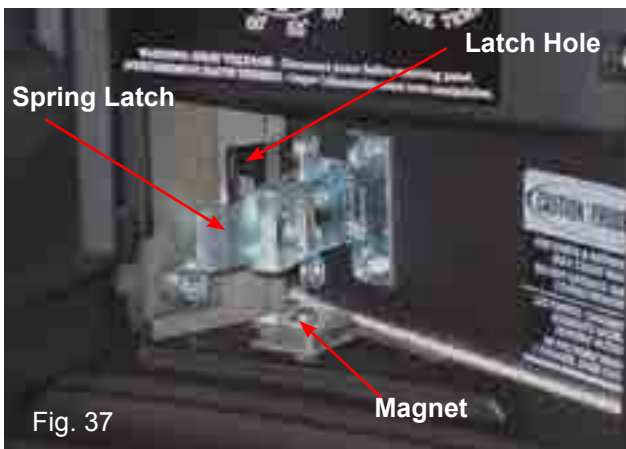

Wiring

Always disconnect the power cord before the unit is pulled from the mounting frame.

As you can see, the control board is easily accessible from the rear with the body pulled out of the frame, even if it is only pulled out several inches.

- Always inspect the wiring harness of the 11 pin socket (large white flat plug where all of the power wires terminate.)
- Always inspect the wiring harness where the wires transfer from the control to the rear inside of the body.
- Make sure there are no worn or frayed areas.

Inspect the wiring harness transition area: This is the area that comes closest to the mounting frame as the unit is slid in and out of the frame.

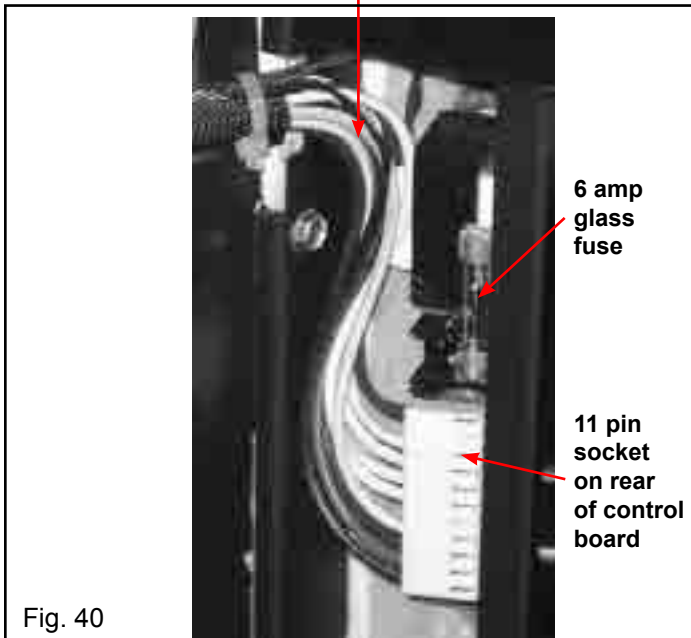

REMINDERS

- Do not allow pellets or sawdust to build up on the hopper lip.
- Inspect the hopper lid gasket for damage. A good hopper lid seal is very important for proper operation.

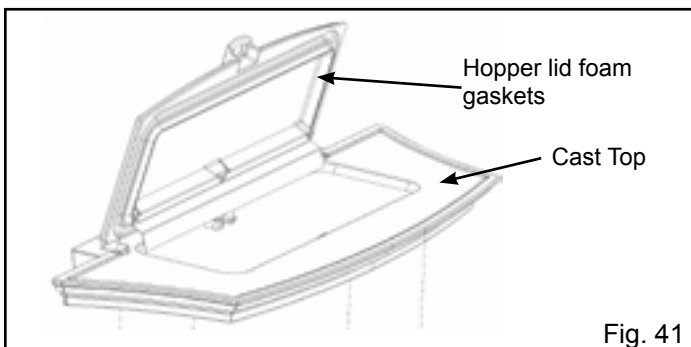

Log Set Option



Install the log bracket with the two thumb screws provided.



Center the log in the firebox opening with the bottom front edge over the thumb screws. The log branch tips only rest on the bracket arms for easy installation and removal.

IMPORTANT NOTE: BEFORE CLEANING THE HEAT EXCHANGERS, THE LOG AND THE LOG BRACKET MUST BE REMOVED.

After the installation is completed, but before the first fire is lit, check and record the high and low draft readings.

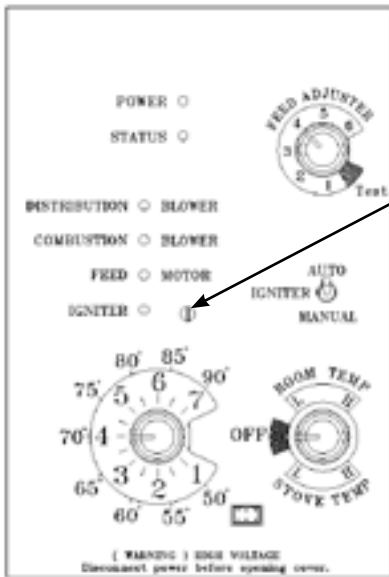

Fig. 44

Combustion Motor Speed Control
Low draft only set point.
 The small straight screwdriver slot is plastic; therefore, the unit can be adjusted while in operation.

These units are pre-tested at the factory with exactly 120 VAC, 60 Hz. They are checked and adjusted for firebox tightness, gasket leakage, motor operation and igniter operation. The stove is then factory set at a high adjustment. **NOTE: Low draft adjustment may be required. The factory low draft setting may not be correct for the unit's permanent installation conditions.**

The control board on the Accentra Insert is equipped with a low draft adjustment port. Located on the control face just to the right of the igniter light. See Figure 44. This voltage adjustment is provided to allow the unit to be adjusted for the household voltage where the unit is going to be in permanent operation. NOTE: The line voltage varies from area to area and often home to home.

The low draft voltage should be adjusted to achieve the most efficient burn on low burn or "maintenance". This voltage adjustment allows the installer to change the low voltage set point approximately 15 volts. This adjustment should be done by the installer during set up because a draft meter reading is **required** to insure proper set up.

If the unit is not adjusted properly, it does not cause a safety concern. If the unit is adjusted too high, only efficiency is lost. If the unit is adjusted too low, the low draft pressure switch will not allow the feeder motor or the igniter to operate.

Fig. 45

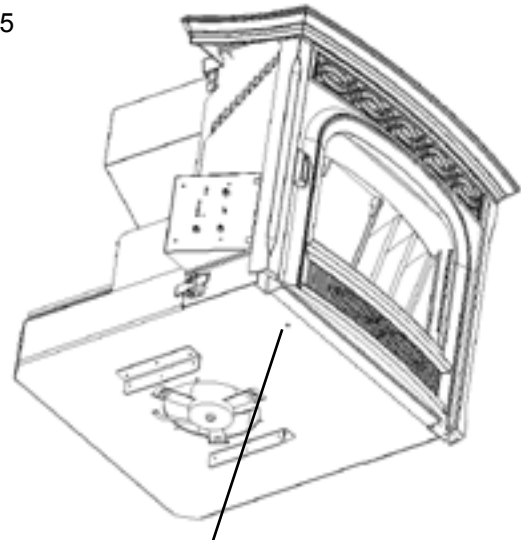

Draft Meter bolt hole location

The head of the plug bolt can be accessed through the bottom distribution air inlet with the cast ash lip removed.

A simple draft test should be performed after completing the flue pipe installation. To record the results for future reference:

1. Plug unit into a 120 VAC, 60 Hz outlet.
2. Close the hopper lid and front view door. Neither pellets or a fire are required for this test.
3. With the mode selector in the "OFF" position, turn the feed adjuster to "TEST".
4. Record the high draft _____ in. W.C. (Normal is -.45 to -.55) The control will be on the High Draft for a total of 1 minute.
5. After 1 minute, the combustion motor will go down to low draft and the distribution blower will go on high. Allow approximately 15 seconds to pass for the combustion motor to slow before checking the low draft.
6. If the low draft is between .30 and .35, record the reading _____ in. W.C. If the reading is higher, slowly turn the set screw counter-clockwise until the draft lowers. If the reading is lower, very slowly turn the set screw clockwise until the draft increases.

NOTE: In some cases, the draft may not go as low as .30 even with the set screw completely counter-clockwise.

Mobile Home Installation

Mobile home installation should be done in accordance with the Manufactured Home and Safety Standard (HUD), CFR 3280, Part 24.

When installing the Accentra in a mobile home several requirements must be followed:

1. The unit must be bolted to the floor. This can be done with 1/4" lag screws through the 5 holes in the base plate shown in Fig. 26.
2. The unit must also be connected to outside air. See page 22. All mobile home installations require the use of outside air, this will increase the heating efficiency of the unit and keep it from suffering any effects associated with room air starvation such as poor combustion and or erratic operation. Periodically check the air inlet for any obstructions such as snow or ice build up.

Kitchen exhaust fans, clothes dryers and other similar devices may cause improper operation of the pellet stove, if, while in use, it keeps the room in a negative pressure, thus allowing pipe joints, not completely sealed, to leak exhaust into the room. Be sure to allow adequate ventilation while using such appliances

3. Floor protection and clearances must be followed. Floor protection and clearances to combustibles must be followed as per installation instructions for the stove. Clearances may only be reduced by means approved by the regulatory authority.
4. Unit must be grounded to the metal frame of the mobile home.
5. Smoke alarms and smoke detectors are recommended to be used with wood and biomass fueled stoves. When opening the firebox door some exhaust may escape into the room and set off the alarm. If this should happen ventilate the room to remove the smoke and reset the alarm, if the alarm would go off when no one was working with the stove ventilate the room and have your home checked to find the source of the leak.

WARNING

MOBILE/MANUFACTURED HOME GUIDELINES DO NOT ALLOW INSTALLATION IN A SLEEPING ROOM.

CAUTION

THE STRUCTURAL INTEGRITY OF THE MOBILE HOME FLOOR, WALL, AND CEILING/ROOF MUST BE MAINTAINED.

Safety Reminders

When installing and operating your Harman Accentra Insert, respect basic safety standards. Read these instructions carefully before you attempt to install or operate the Accentra Insert. Failure to do so may result in damage to property or personal injury and may void the product warranty.

Consult with your local building code agency and insurance representative before you begin your installation to ensure compliance with local codes, including the need for permits and follow-up inspections.

CAUTION: This appliance must be vented to the outside.

Due to high temperatures, this stove should be placed out of traffic and away from furniture and draperies.

Children and adults should be alerted to the hazards of high surface temperatures and should stay away to avoid burn to skin and/or clothing.

Young children should be carefully supervised when they are in the same room as the stove.

Clothing and other flammable materials should not be placed on or near this stove.

Installation and repair of this stove should be done by a qualified service person. The appliance should be inspected before use and at least annually by a qualified service person. More frequent cleaning will be required. It is imperative that control compartments, burners, and circulating air passageways of this stove be kept clean.

CAUTION

**THE STOVE IS HOT WHILE IN OPERATION.
KEEP CHILDREN, CLOTHING AND FURNITURE AWAY.
CONTACT MAY CAUSE SKIN BURNS.**

WARNING

**KEEP COMBUSTIBLE MATERIALS SUCH AS GRASS,
LEAVES, ETC. AT LEAST 3 FEET AWAY FROM THE
POINT DIRECTLY UNDER THE VENT TERMINATION.**

WARNING

**USE OF IMPROPER FUELS, FIRE STARTERS OR
ALTERING THE STOVE FOR HIGHER HEAT OUTPUT
MAY CAUSE DAMAGE TO THE STOVE AND COULD
RESULT IN A HOUSE FIRE. USE ONLY APPROVED
FUELS AND OPERATION GUIDELINES**

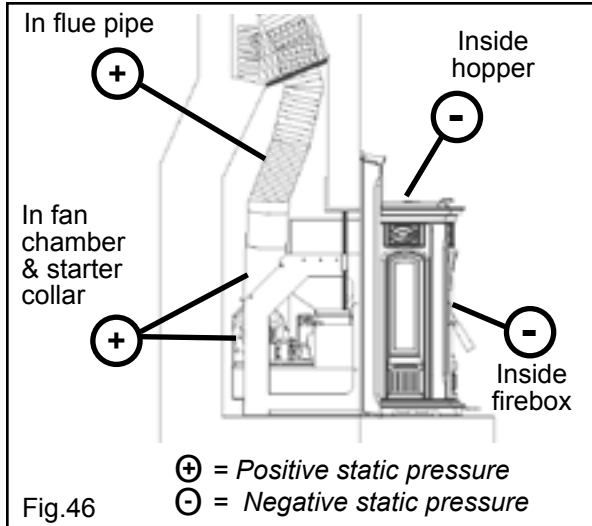

A combustion blower is used to extract the combustion gases from the firebox. This causes a negative pressure in the firebox and a positive pressure in the venting system as shown in fig. 46. The longer the vent pipe and more elbows used in the system, the greater the flow resistance.

The recommended maximum flue lengths for the Accentra Insert are as follows:

4" Stainless Steel Flex: 30 Lineal ft. Vertical*

4" PL Vent Pipe:

4" PL Vent Pipe: 30 Lineal ft. Vertical*

4" PL Vent Pipe: 14 ft. Vertical w/1-90° and 4 lineal ft. horizontal*

If additional 4" PL Vent fittings are required, the overall length must be reduced by:

- Vertical 90° or T: 2.5'
- Vertical 45°: 1.5'
- Horizontal 90° or : 5.0'
- Horizontal 45°: 2.5'

3" PL Vent Pipe:

20 Lineal ft. vertical*

8 Lineal ft. vertical w/1-90° & 4 lineal ft. horizontal*

If additional 3" PL Vent fittings are required, the overall length must be reduced by:

- Vertical 90° or T: 2.0'
- Vertical 45°: 1.0'
- Horizontal 90° or T: 4.0'
- Horizontal 45°: 2.0'

* Long runs of flex or PL vent pipe installed directly vertical from the flue stub may require more frequent cleaning due to fly ash falling off inside and collecting directly above the combustion blower outlet.

Any use of horizontal venting will require more frequent cleaning. It is the responsibility of the installer to make sure the entire flue configuration is accessible for cleaning.

4" stainless steel flex vent piping is only allowed for use in masonry fireplaces and chimneys or factory built wood burning fireplaces with class A metal chimneys. All pellet vent pipe must be secured together either by means provided by pipe manufacturer or by 3 screws at each joint.

Use only the specified venting components. Use of any other components will void the product warranty and may pose a hazard.

Do Not Install A Flue Damper In The Exhaust Venting System Of This Appliance.

DO NOT CONNECT THIS UNIT TO A CHIMNEY FLUE SERVING ANOTHER APPLIANCE.

Avoiding Smoke and Odors

Negative Pressure, Shut-down, and Power Failure:

To reduce the probability of back-drafting or burn-back in the pellet burning appliance during power failure or shut-down conditions, the stove must be able to draft naturally without exhaust blower operation. Negative pressure in the house will resist this natural draft if not accounted for in the pellet appliance installation.

Heat rises in the house and leaks out at upper levels. This air must be replaced with cold air from outdoors, which flows into lower levels of the house. Vents and chimneys into basements and lower levels of the house can become the conduit for air supply, and reverse under these conditions.

Outside Air:

Hearth & Home Technologies recommend attaching outside air in all installations, especially lower level and main floor locations.

Per national building codes, consideration must be given to combustion air supply to all combustion appliances. Failure to supply adequate combustion air for all appliance demands, may lead to back-drafting of those and other appliances.

When the appliance is side-wall vented: The air intake is best located on the same exterior wall as the exhaust vent outlet and located lower on the wall than the exhaust vent outlet.

When the appliance is roof vented: The air intake is best located on the exterior wall oriented towards the prevailing wind direction during the heating season.

The outside air connection will supply the demands of the pellet appliance, but consideration must be given to the total house demand. House demand may consume some air needed for the stove, especially during a power failure. It may be necessary to add additional ventilation to the space in which the pellet appliance is located. Consult with your local HVAC professional to determine the ventilation demands for your house.

Vent Pipe

Be sure to use approved pellet vent pipe wall and ceiling pass-through fittings to go through combustible walls and ceilings. Be sure to use a starting collar to attach the venting system to the stove. The starting collar must be secured to the flue stub with at least three screws, and sealed with high temp silicone caulking.

4" stainless steel flex vent piping is only allowed for use in masonry fireplaces and chimneys or factory built wood burning fireplaces with class A metal chimneys.

Pellet venting pipe (also known as Type L or PL vent) is constructed of two layers with air space between the layers. This air space acts as an insulator and reduces the outside surface temperature to allow a clearance to combustibles of only 3 inches. The sections of pipe lock together to form an air tight seal in most cases; however, in some cases a perfect seal is not achieved. For this reason and the fact that the Accentra Insert operates with a positive vent pressure, we specify that the joints also be sealed with silicone.

When passing through an exterior wall or roof, be sure to use the appropriate pass-through device providing an adequate vapor barrier. Venting manufacturers generally provide these pass-through devices.

Outside Air

The outside air kit consists of a flue stub pipe, fiberglass gasket, silicone gasket, intake box and a section of flex pipe. See Fig. 47.

An adjustable chimney intake extension, part # 1-00-674104 is available to be used on masonry chimneys only. See Fig. 48.

Additional information and diagrams can be found on pages 23 thru 27, under venting.

To install outside air, use kit part number 1-10-674080. Follow the installation instructions provided with the kit.

Vent Configurations:

To reduce probability of reverse drafting during shut-down conditions, Hearth & Home Technologies strongly recommends:

- Installing the pellet vent with a minimum vertical run of five feet, preferably terminating above the roof line.
- Installing the outside air intake at least four feet below the vent termination.

To prevent soot damage to exterior walls of the house and to prevent re-entry of soot or ash into the house:

- Maintain specified clearances to windows, doors, and air inlets, including air conditioners.
- Vents should not be placed below ventilated soffits. Run the vent above the roof.
- Avoid venting into alcove locations.
- Vents should not terminate under overhangs, decks or onto covered porches.
- Maintain minimum clearance of 12 inches from the vent termination to the exterior wall. If you see deposits developing on the wall, you may need to extend this distance to accommodate your installation conditions.

Hearth & Home Technologies assumes no responsibility for, nor does the warranty extend to, smoke damage caused by reverse drafting of pellet appliances under shut-down or power failure conditions.

100% Outside Air Kit

100% Outside Air Kit
1-00-674080

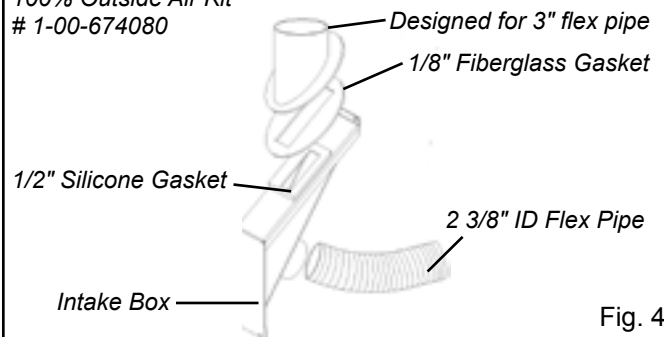

Fig. 47

Adjustable Chimney Intake Extension Part # 1-00-674104

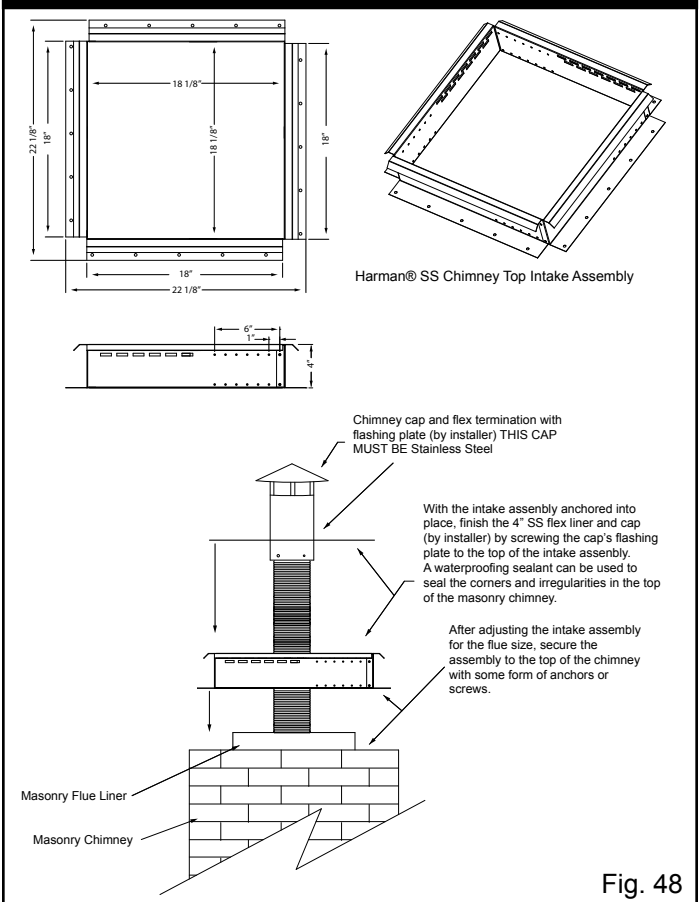

Fig. 48

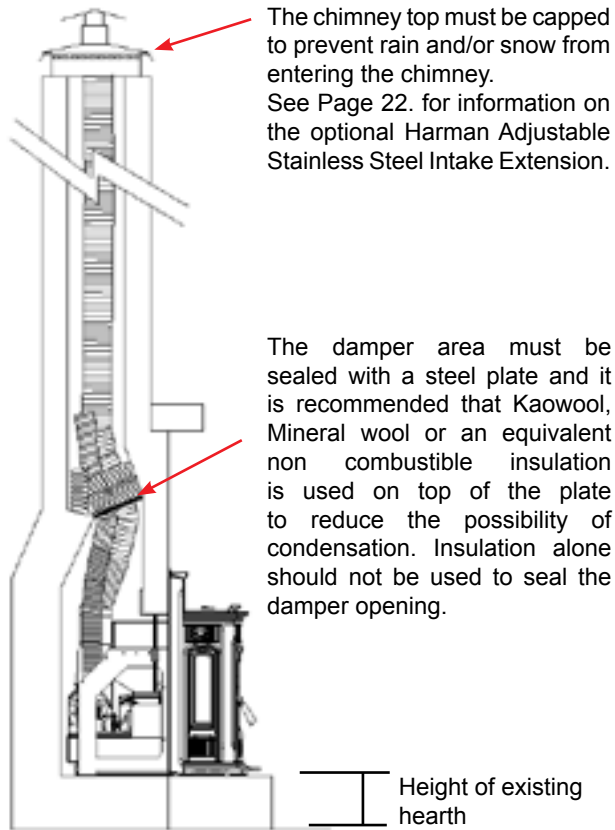

Fig. 49

#1 Installing into an existing fireplace chimney

This method provides excellent venting with 100% outside air which is the most efficient operation of this unit. This method also provides natural draft in the event of a power failure.

A 4 inch stainless steel flex pipe is needed for the flue pipe, and 3" aluminum or Stainless Steel Flex Pipe is used for the intake.

WARNING

CHIMNEY CONNECTOR PIPE MAY NOT PASS THROUGH CONCEALED SPACES INCLUDING AN ATTIC, ROOF SPACE, CLOSET, FLOOR OR CEILING.

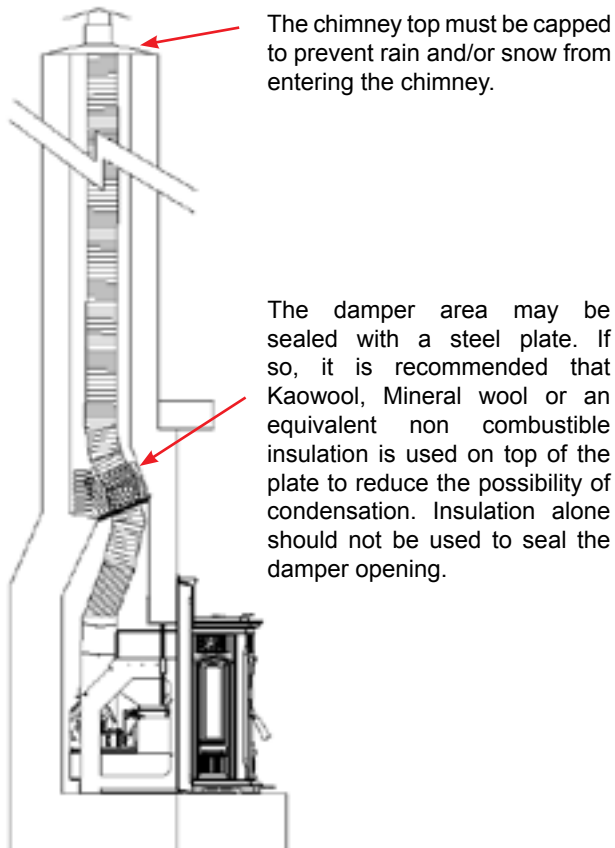

Fig. 50

#2 Installing into an existing fireplace chimney

This method provides excellent venting for normal operation. This method also provides natural draft in the event of a power failure.

A cap should be installed on the chimney to keep out rain. Combustion air is provided from the living area and enters the feed system from around the wing and stove body spaces.

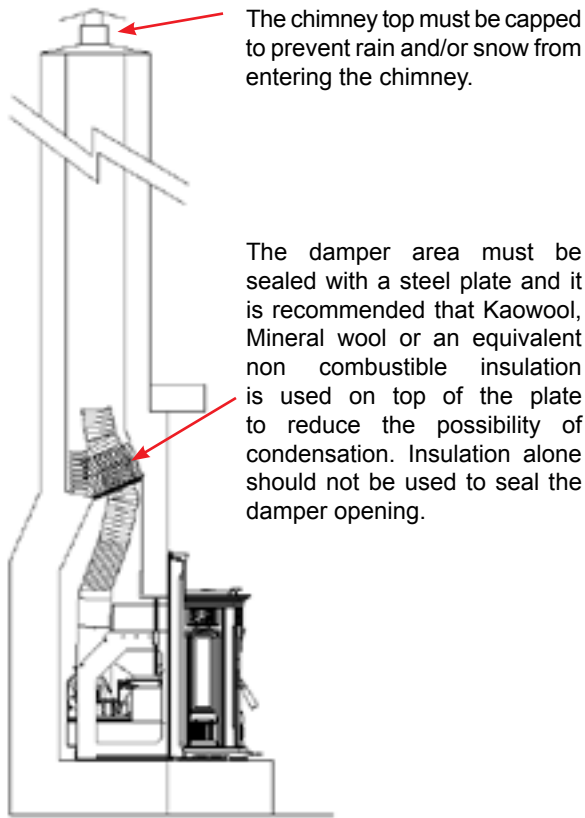

Fig. 51

#3 Installing into an existing chimney

This method provides excellent venting for normal operation. This method also provides natural draft in the event of a power failure. If the chimney condition is questionable you may want to install a liner as in method #2.

This is the minimum allowed vent pipe using 4" stainless steel flex pipe.

The vent pipe must extend past the damper sealing area by at least 12 inches.

Note: The insulation material must not be allowed to expand to the point that it covers the end of the flex pipe.

The chimney should be capped with any style cap that will not allow rain or snow to enter.

In some places in the US and Canada, it is required that the vent pipe extend all the way to the top of the chimney. Check your local codes.

WARNING
CHIMNEY CONNECTOR PIPE MAY NOT PASS THROUGH CONCEALED SPACES INCLUDING AN ATTIC, ROOF SPACE, CLOSET, FLOOR OR CEILING.

#4 Preferred method

This method provides excellent venting for normal operation and in a fireplace with inadequate flue space, or a height of over 30 feet. A 3" or 4" PL vent pipe should be used with the needed swivel flue stub.

NOTE: The flue stub insulation wrap must still be used with this method. See page 14, Fig. 27 & 29. With a 100% outside air kit the outside air can be installed in the same manner as the flue pipe.

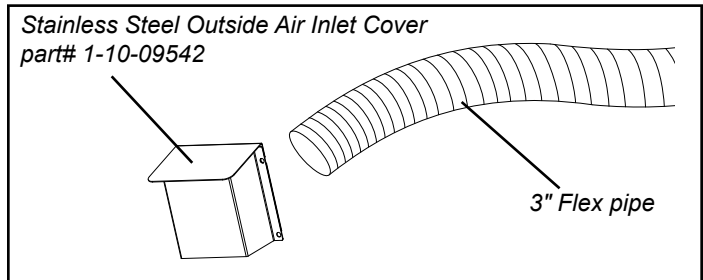

CAUTION
KEEP COMBUSTIBLES (SUCH AS GRASS, LEAVES, ETC.) AT LEAST 3 FEET AWAY FROM THE FLUE OUTLET ON THE OUTSIDE OF THE BUILDING.

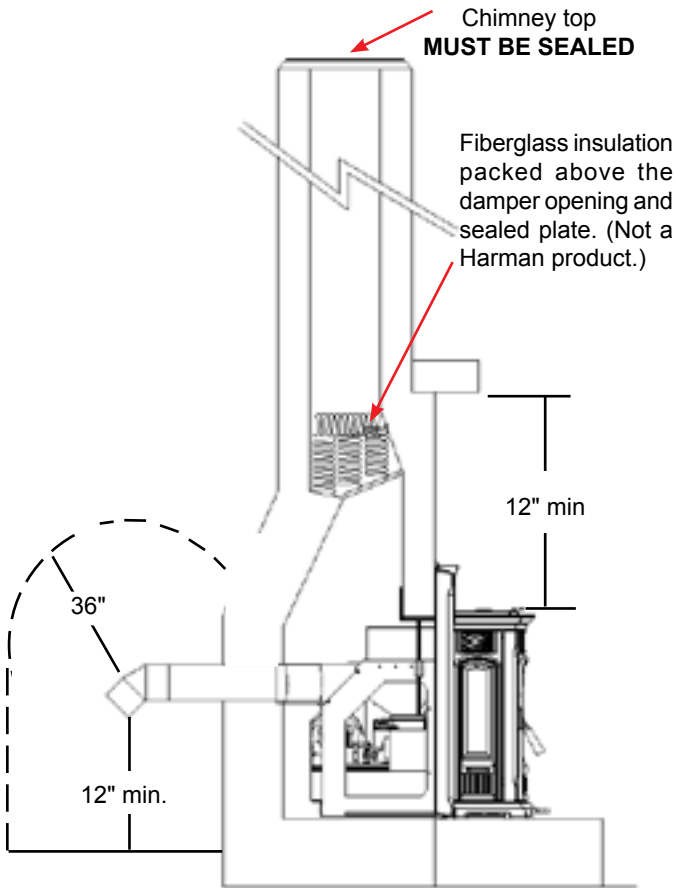

Fig. 52

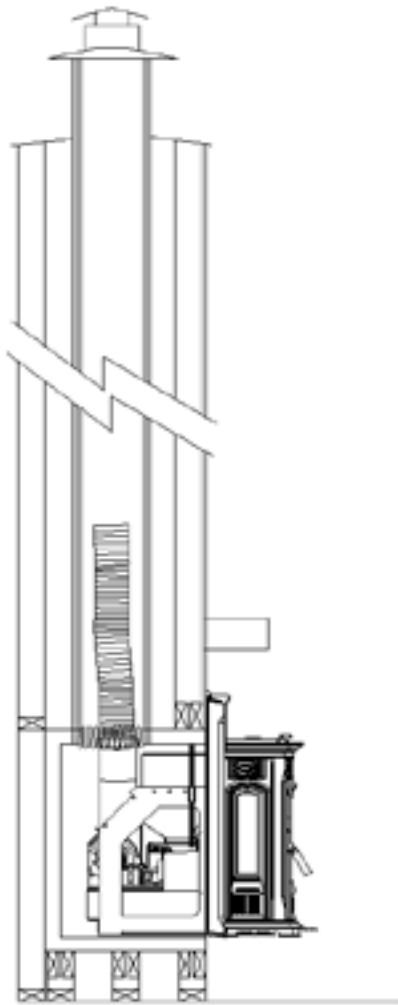

Fig. 53

Installing the Accentra Insert into an existing factory built wood burning fireplace

When installing the Accentra Insert into a factory built wood burning fireplace, the Manufactured Fireplace Installation Kit # 1-00-674205 must be used. In addition, several things need to be taken into consideration.

The size of the fireplace opening. Will the unit fit into the opening? Many of these units have metal smoke shields inside the top that can be removed to gain height. Often the side and rear refractory can be removed to gain depth and width. In some circumstances, the front lower lip or grill work may also be removed. Be sure and follow the guidelines in the kit instructions. Because of the special track system, it is also permitted to remove the floor refractory and/or insulation in the bottom of the manufactured fireplace, right down to the outer sheet metal, which must be left in place for floor protection under the insert mounting frame. Floor protection guidelines, as listed on page 14 must also be followed.

Note: If the Harman Accentra Insert is installed into a factory built wood burning fireplace, this label (Harman part # 3-90-00675) **MUST** be attached to the altered fireplace. This label is included in the Manufactured fireplace installation kit.

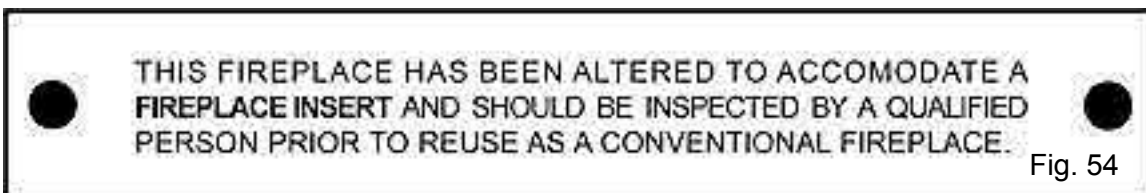

Fig. 54

OPTIONAL HOPPER CONFIGURATIONS FOR SMALLER FIREPLACE OPENINGS:

The Harman Accentra Insert can be factory built with shorter hopper configurations.

The standard requires a 24" opening. Part #1-90-00674

Option 1: Requires a 22" opening height. Part #1-90-00675

Option 2: Requires a 20" opening height. Part #1-90-00676

Keep in mind the hopper capacities will decrease with the optional heights.

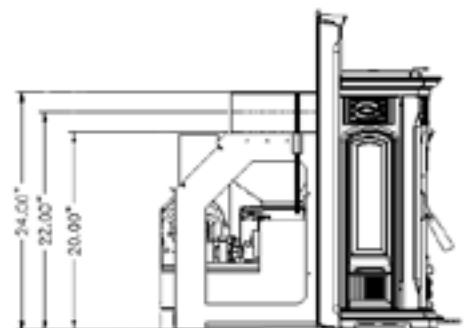

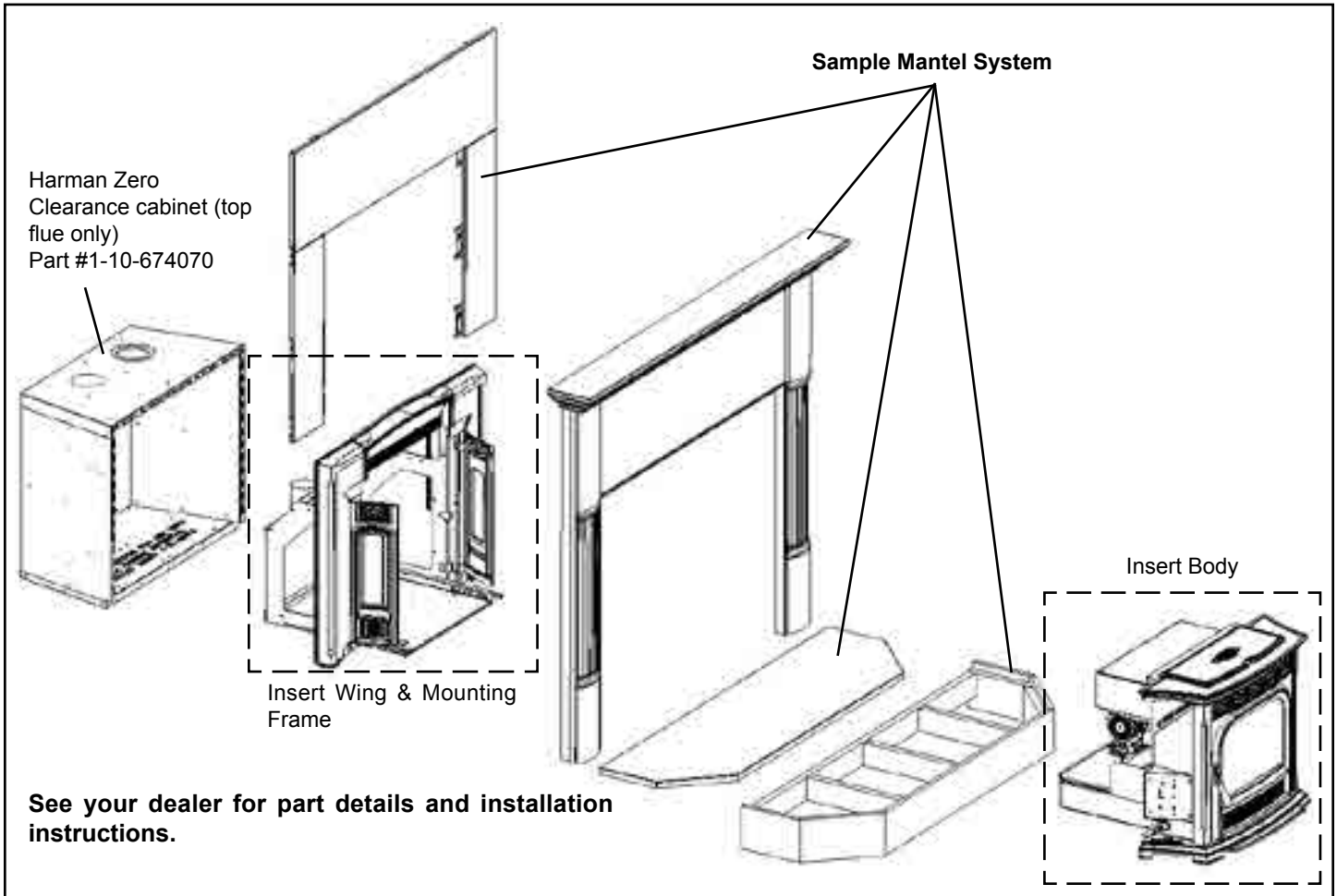

Fig. 55

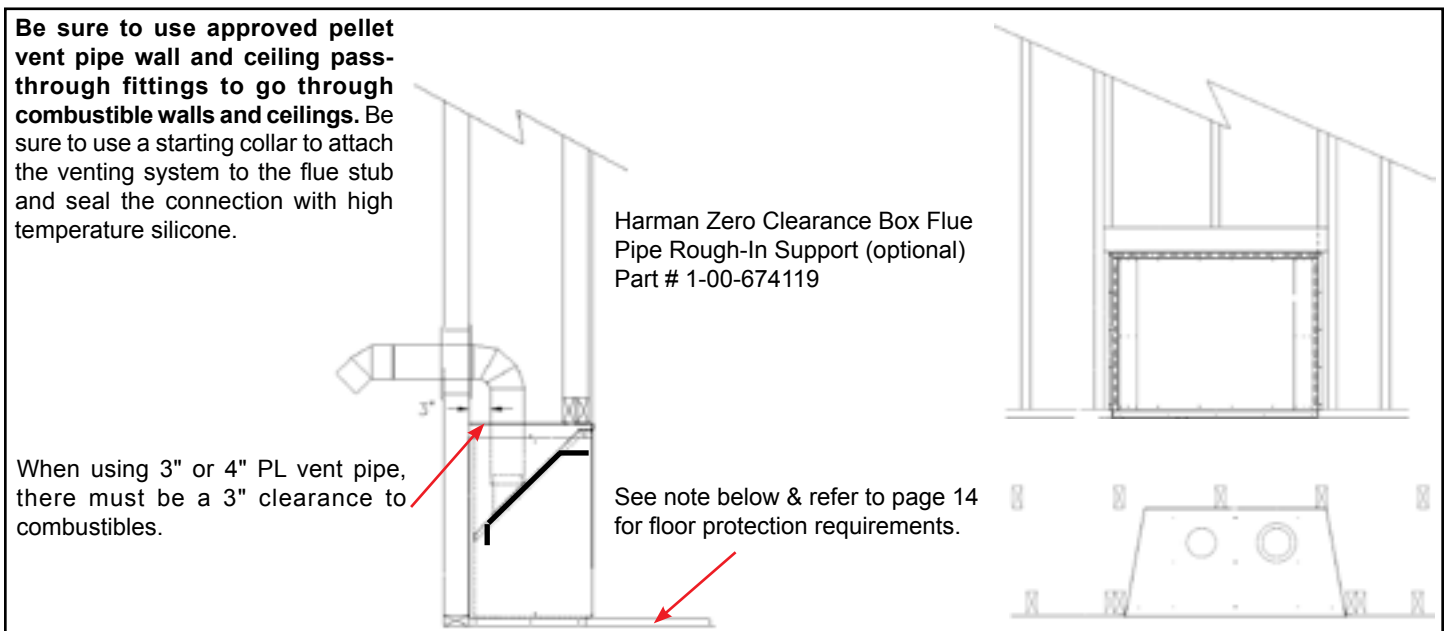

Fig. 56

Note: Combustible materials are allowed to touch the cabinet anywhere behind the front mounting flanges except vent clearance areas. The hearth substructure may be built of combustible material although a non-combustible hearth surface (tile, stone, metal, glass) must extend as far as shown on the appliance's Testing Label.

Requirements for Terminating the Venting

WARNING: Venting terminals must not be recessed into a wall or siding.

NOTE: Only PL or L vent pipe wall pass-throughs and fire stops should be used when venting through combustible materials.

NOTE: Always take into consideration the effect the prevailing wind direction or other wind currents will cause with flyash and /or smoke when placing the termination.

In addition, the following must be observed:

- A. The clearance above grade must be a minimum of 12".
- B. The clearance to a window or door that may be opened must be a minimum of 48" to the side and 48" below the window/door, and 12" above the window/door. **(with outside air installed, 18" to side and below)**
- C. A 12" clearance to a permanently closed window is recommended to prevent condensation on the window.
- D. The vertical clearance to a ventilated soffit located above the terminal within a horizontal distance of 2 feet (60 cm) from the center-line of the terminal must be a minimum of 18".
- E. The clearance to an unventilated soffit must be a minimum of 12".
- F. The clearance to an outside corner is 11" from center of pipe.
- G. The clearance to an inside corner is 12".

- H. A vent must not be installed within 3 feet (90 cm) above a gas meter/regulator assembly when measured from the horizontal center-line of the regulator.
- I. The clearance to service regulator vent outlet must be a minimum of 6 feet.
- J. The clearance to a non-mechanical air supply inlet to the building or the combustion air inlet to any other appliance must be a minimum of 48".
- K. The clearance to a mechanical air supply inlet must be a minimum of 10 feet. **(with outside air installed, 6 feet)**
- L. The clearance above a paved sidewalk or a paved driveway located on public property must be a minimum of 7 feet.
- M. The clearance under a veranda, porch, deck or balcony must be a minimum of 12 inches. **(B. also)**

NOTE: The clearance to vegetation and other exterior combustibles such as mulch is 36" as measured from the center of the outlet or cap. This 36" radius continues to grade or a minimum of 7 feet below the outlet.

Certain Canadian and or Local codes or regulations may require different clearances.

A vent shall not terminate directly above a side-walk or paved driveway which is located between two single family dwellings and serves both dwellings.

Only permitted if veranda, porch, deck, or balcony is fully open on a minimum of 2 sides beneath the floor.

NOTE: Where passage through a wall, or partition of combustible construction is desired, the installation shall conform to CAN/CSA-B365. (If in Canada)

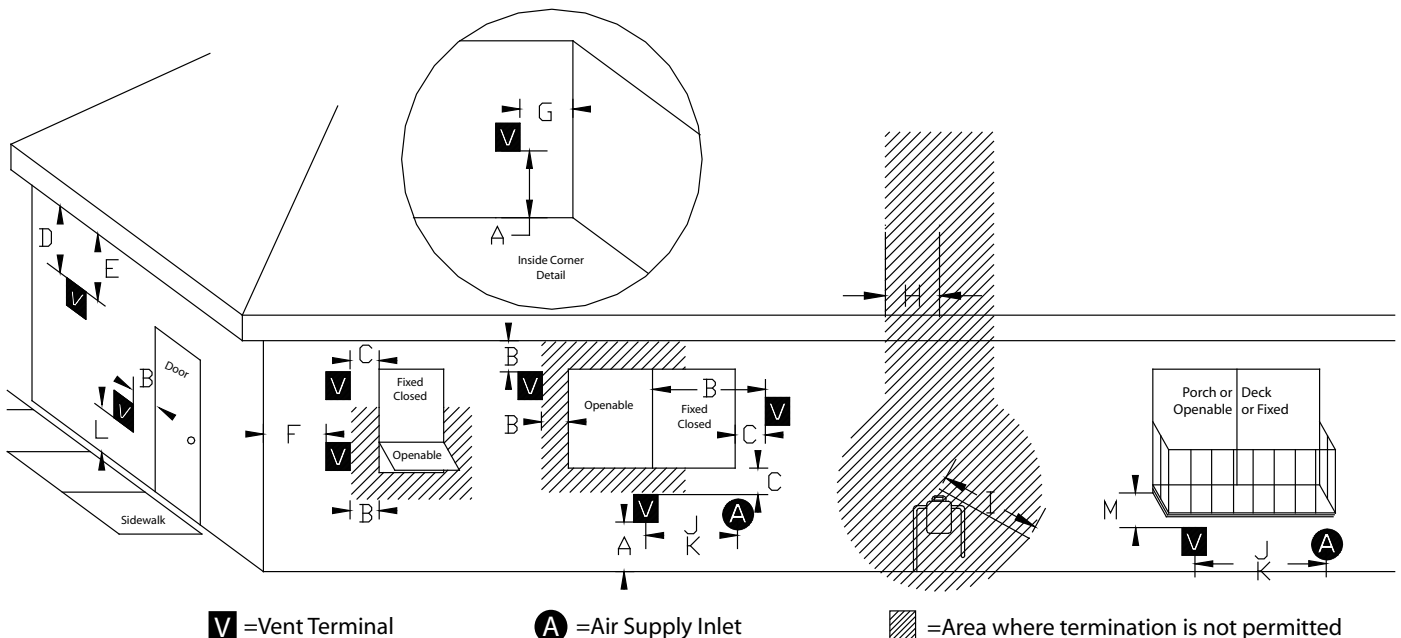

The glass used in your stove is manufactured to exact standards to withstand the high heat of the fire, but like all glass, it must be treated with common sense and care. Never abuse the glass by slamming the door shut or striking the glass with a heavy object. If the glass is broken or damaged, do not operate the stove until it has been replaced.

Glass - Replacement

If the stove's glass is cracked or broken, you must replace it before operating your stove. Remove pieces carefully. Replace glass only with Harman replacement glass; **do not use substitutes.**

Carefully remove damaged glass, gasket material, and hold down clips (set aside).

Install the self adhesive 1/4" gasket material around the front face of the glass. Set the glass panel and gasket gently onto the door. Install the hold down clips and tighten with bolts.

Glass - Cleaning

Sometimes it will be necessary to clean accumulated ash from the glass surface; allowing this ash to remain on the glass for long periods can result in "etching" due to the acidity of the ash. Never clean the glass while it is hot, and **do not** use abrasive substances. Wash the surface with cool water, and rinse thoroughly. You may wish to use a non-abrasive cleaner specifically designed for use on stove glass. In any case, dry thoroughly before relighting your stove.

Disposal of ashes: Ashes should be placed in a metal container with a tight fitting lid. The closed container of ashes should be placed on a non-combustible floor or on the ground, well away from all combustible materials, pending final disposal. If the ashes are disposed of by burial in soil or otherwise locally dispersed, they should be retained in the closed container until all cinders have thoroughly cooled.

Soot and fly ash: Formation and need for removal. The products of combustion contain small particles of fly ash. The fly ash will collect in the exhaust venting system and will restrict the flow of the flue gases. Pellet fuels have different ash contents depending on what type of wood has been used to make the pellets. **We recommend to clean the system after approximately 1 ton of pellets have been burned and judge from that how often the stove should be cleaned, remember if you change pellets it may change how often you have to clean your stove.**

When burning wood slowly, the potential exists for creosote to form. The venting system should be inspected periodically throughout the heating season to determine if a creosote buildup has occurred. If a significant layer of creosote has accumulated (3mm or more), it should be removed to reduce the risk of a chimney fire. If a fire occurs, call the fire department, shut down the stove, and evacuate the residence. Before using the appliance, have the venting system thoroughly inspected and replace any damaged components.

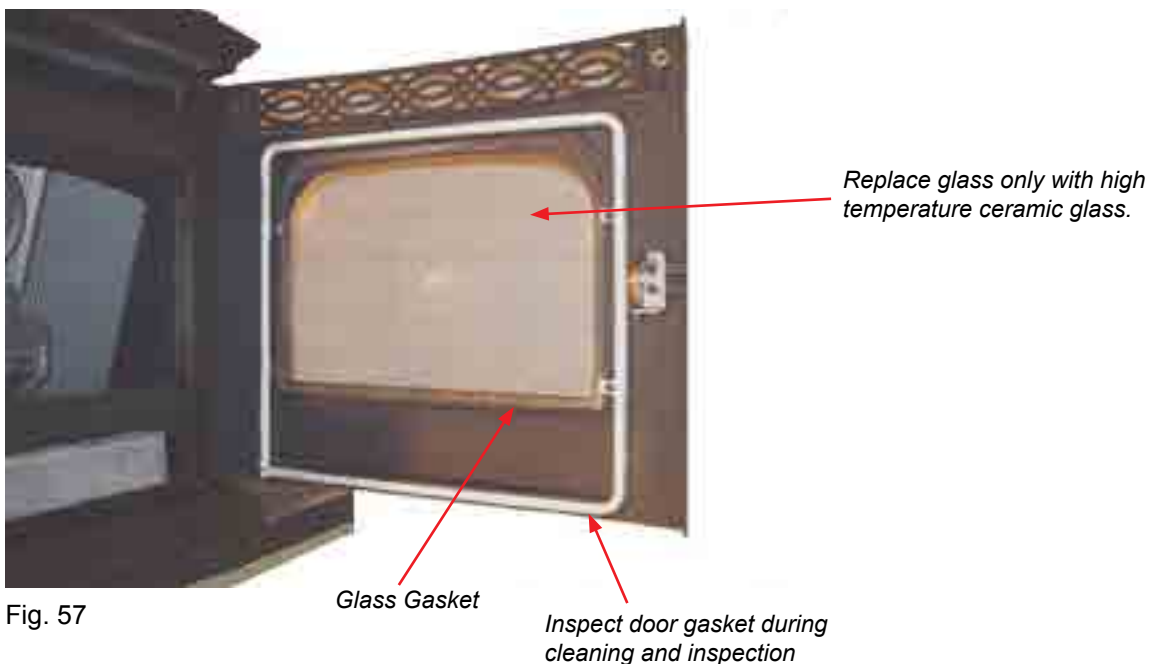

Fig. 57

Glass Gasket

Inspect door gasket during cleaning and inspection



Burn Pot Cleaning and Maintenance

Whenever adding fuel, take the opportunity to clean the burn pot. **(Weekly at minimum)**

- Scrape the top holed surface and sides of the burn pot down to auger tube. (Fig. 58) It is not necessary to completely remove all material from the burn pot. The excess will be pushed out during the next use.

Monthly, or after each ton of fuel burned:

- Loosen the (2) wing thumb screws on the lower front angle of the burn pot. (Fig. 59)
- Lift off the clean-out cover (Fig. 59) to open the bottom clean-out chamber. (Fig. 60)



DANGER

Disconnect the power to the unit before removing cover.

- Clean ash buildup from inside the chamber while cover is off. Use the scraper to tap on the top front edge of the burn pot. This will help knock pieces of ash, loosened by the scraping process, down through the holes. It also helps knock scale off of the igniter element.

Figure 60

The igniter is made to be removable for service by insulated male/female wire connectors. These connections between the hot leads (the wires inside the burn pot) and the cold leads (the wires from the control board) are always pulled to the inside rear of the feeder body. **(Not coiled inside the burn pot.)**

It is very important that these connections are to the inside rear of the feeder body. Also, the extra wire of the igniter wire service loop must be pulled out through the rear of the feeder and tied up so that it will not be damaged by any moving parts.

Burn pot igniter
Igniter hot lead wires
(High temperature)



WARNING

Use caution when cleaning burn pot clean-out chamber. Do not damage the high temperature igniter wires.

Note: The hot lead/cold lead connection must always be pulled to the rear of the feeder body before operation.

Viewed from below through the ash pan opening.



Monthly Cleaning- continued:

There is a 2" square exhaust tube on each side (lower left and right corners) of the firebox. They can only be seen with the cast heat exchanger covers removed.

Cleaning the Heat Exchanger tubes

Using the cleaning brush provided, clean these tubes after every 1 ton of pellets are used.

These tubes are an important part of the heat exchanger. Efficiency will be lost if they are not properly maintained. The right side tube is a straight passage to the combustion blower chamber. The Left side tube follows straight back then makes a right turn, across the back, to the combustion chamber. You will need to use the entire length of the cleaning brush handle to properly clean this tube.



Cleaning the Heat Exchanger

The accordion heat exchanger surfaces are the primary source of heat transfer into the room. Therefore, it is very important to keep them clean from flyash and soot buildup.

- The heat exchanger surfaces should be cleaned after approximately every 1 ton of pellets are used.
- Use the scraper provided to clean all the way into the point.
- Note: An old paint brush works well to clean these surfaces.
- Note: The unit "must be cold" before using anything other than a wire brush.
- There are 2 primary air inlet holes on the rear flange of the burnpot. They should be checked for blockage and cleaned with a vacuum if necessary. Note: The bottom of the flame guide has 2 notches that match the holes.





Feeder Chamber

This chamber may get a buildup of fines from the feeder mechanism movement. This area should be checked and cleaned at least once a year.

To remove the feeder cover:

- Remove the 5/16" wing nut.
- Slide the cover off of the threaded stud.
- Inspect and clean the inner chamber if necessary. See Fig. 65.
- Reinstall the cover making certain it is centered on the feeder body and tighten as tightly as you can by hand.

The combustion blower is made to be removed easily for inspection and cleaning. See Fig. 67.

The combustion blower is mounted on a precision cut gasketless mounting plate. This plate is held into place with (3) thumb screws. See Fig. 67.

To remove the combustion blower:

- Turn the thumb screws counterclockwise approximately 5 turns. Rotate the entire assembly counter clockwise until the points of the retaining slots are visible.
- Remove the blower assembly with the fan blade by pulling it directly away from the blower housing.
- The cord on the motor is long enough to allow the motor to be set down on the black plastic fan cover. This allows for easy access to inspect and clean the area. See Fig. 66.
- With the blower assembly out, inspection should be done on the surfaces of the blower assembly and the housing opening where they meet. These surfaces **MUST** be clean and free from dirt, grit, flyash, soot or nicks in the metal. This gasketless seal relies on an extremely close tolerance. Therefore, anything other than a clean joint may cause exhaust gases and/or flyash to escape.
- The assembly can only be reinstalled in one position: with the motor winding in the upward location. See Fig. 67. The mounting plate will not allow for any other position.
- Always make sure that the assembly is fully seated and the (3) thumb screws are tightened before operating the unit.

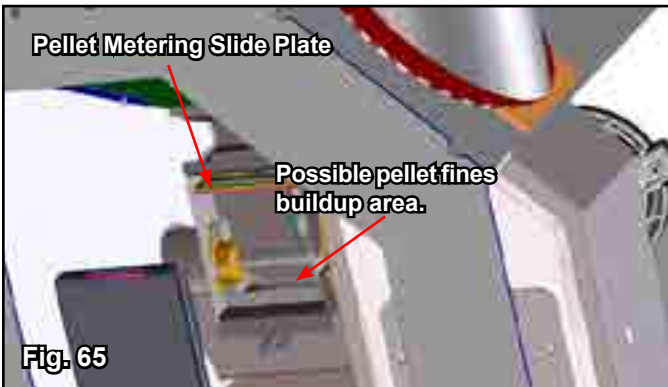

Accentra Insert Motor & Component Locations

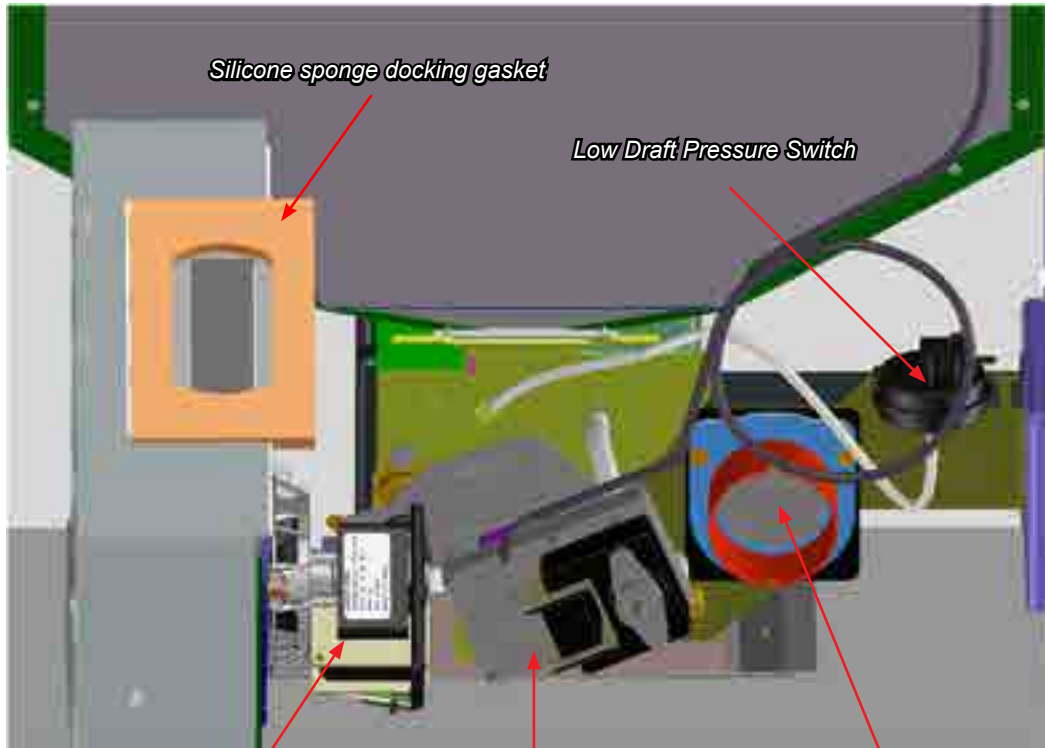

Silicone sponge docking gasket

Low Draft Pressure Switch

Combustion Motor

Feed Motor

Backdraft Damper Assembly

Always check to see if the damper plate swings freely inward and that the seating edges are not covered with dirt or lint.

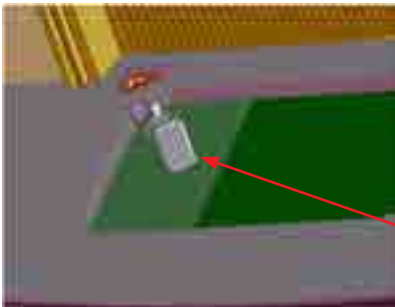

Hopper Lid Position Switch

Accentra Pellet Insert Safety Devices

The **Control Board/ESP** combination is responsible for all high limit safety control. There are 2 high limits, one normal operation high limit and one backup high limit. The control has an automatic diagnostic circuit that continuously monitors the ESP and Room Sensor for faults. If a fault should occur, the control sends a status alert and at the same time the unit goes down to minimum feed/minimum burn as a safety condition.

Distribution Blower (under unit) See Fig. 10, Page 9.

The **Hopper Lid Position Switch** is found in the rear corner of the hopper opening. If the hopper lid is not fully closed, the switch opens, interrupting the power to the feed motor and the igniter circuits. This prevents possible injury from reaching into the feeder mechanism during operation.

The **Low Draft Pressure Switch** is a differential pressure switch that monitors the negative pressure (Draft) in the firebox. If the draft becomes too low for proper combustion, the switch opens, cutting power to the feed motor and the igniter circuits. This switch is connected into the AC (high voltage) wiring.

STOVE DOES NOT FEED

1. No fuel in hopper.
2. Firebox draft may be too low for sensing switch in feeder circuit to operate. **Check for closed doors**, loose or missing gasket on doors or hopper lid.
3. Hopper lid must contact the lid position switch.
4. Feed motor will not run until the ESP control senses a certain temperature. Maybe you did not put enough fuel or starting gel in the burn pot before manually lighting the fire.
5. Restriction in the hopper or feeder. Remove all fuel and examine. Clear the obstruction.
6. Feed motor has failed.

PARTIALLY BURNED PELLETS

1. Feed rate too high.
2. Poor air to fuel mixture. (Check burn pot clean-out cover and air intake).
3. Burn pot or heat exchanger tubes may need to be cleaned.
4. Combination of all the above.
5. **#6 status blink**: A 6 blink control board status indication is caused by poor or incomplete combustion. The circuit board has the ability to track the combustion through feed settings and ESP temperatures. When the control board has calculated poor or incomplete combustion, it will shut down the unit as a safety feature. (Poor or incomplete combustion is a contributor of creosote which may cause a chimney fire)

A 6 blink status may be caused by several things:

1. Blocked or partially blocked flue.
2. Blocked or partially blocked inlet air.
 - a. Backdraft damper on the inlet pipe may be stuck closed.
 - b. If outside air is installed, the inlet cover may be blocked.
3. The air chamber under the burnpot may be filled with fines and small bits of ash.
4. The holes in the burnpot may be getting filled with ash or carbon buildup.
5. Combustion blower fan blades may need cleaned.
6. Fuel restrictions as noted above.

SMOKE SMELL

Seal the vent pipe joints and connection to stove with silicone. The exhaust vent is the only part of the system that is under positive pressure.

FIRE HAS GONE OUT- Check for status light.

1. No fuel in hopper.
2. Draft is too low, blocked flue.
3. Something is restricting fuel flow.
4. Hopper lid not closed properly.
5. Feed motor or combustion blower has failed.

SMOKE IS VISIBLE COMING OUT OF VENT

1. Air-fuel ratio is too rich.
 - a. Feed rate too high.
 - b. Draft too low caused by a gasket leak.

LOW HEAT OUTPUT

1. Feed rate too low
2. Draft too low because of gasket leak.
3. Poor quality or damp pellets
4. Combination of 1 and 2.

Helpful Hints

Cleaning Burn Pot

Whenever your stove is not burning, take the opportunity to scrape the burn pot to remove carbon buildup. A vacuum cleaner is handy to remove the residue. Be sure the stove is cold if you use a vacuum.

Carbon buildup can be scraped loose with the fire burning using the special tool provided with your stove. Scrape the floor and sides of the burn pot. The carbon will be pushed out by the incoming fuel. Always wear gloves to do this.

Removing Ashes

Turn the Temp Dial to number 1 approximately 30 minutes before removing ashes. This will result in a cooler stove and ash pan.

Maximum Feed Adjuster settings are not needed in most cases. Operating in the normal range (#4) is recommended when maximum heat output is not required. The ESP probe prevents the stove from being over-fired. Keep the stove free of dust and dirt.

Fuel

The Accentra is approved for burning any grade of pelletized bio-mass fuel. It is also approved for burning shelled corn in a mixture with wood pellets, up to 50%. (See Page 46)

It should be noted, however, that higher ash content will require more frequent ash removal, scraping of the burn pot, and may provide less BTU's per pound.

The moisture content of pellets must not exceed 8%, and corn must not exceed 15%. Higher moisture will rob BTU's and may not burn properly.

Fuel should **not** be stored within the stove installation clearances or within the space required for charging and ash removal. See Page 14.

57 lbs. - 25.85 kg
 48 lbs. - 21.75 kg
 38 lbs. - 17.25 kg

Unit #1-90-00674 - Hopper Capacity
 Unit #1-90-00675 - Hopper Capacity
 Unit #1-90-00676 - Hopper Capacity

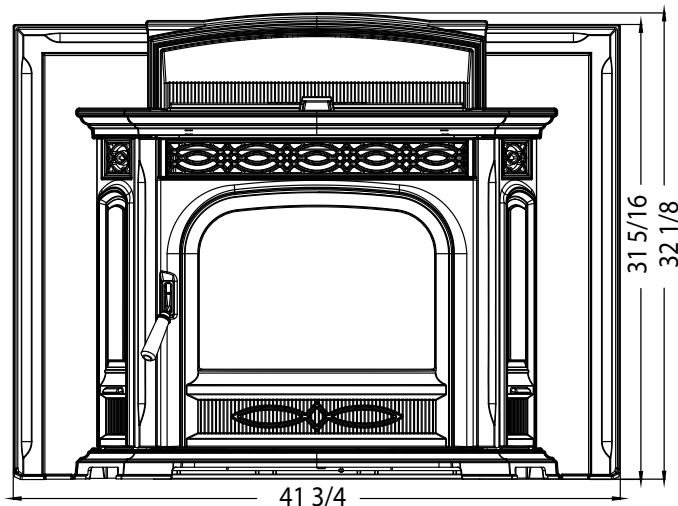
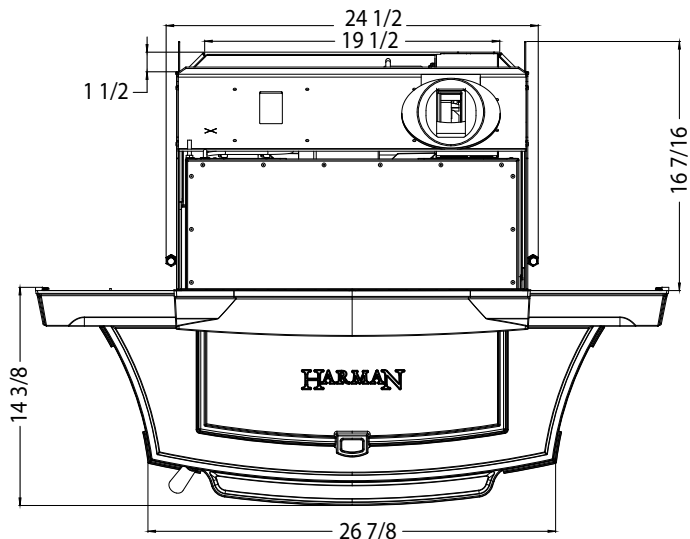
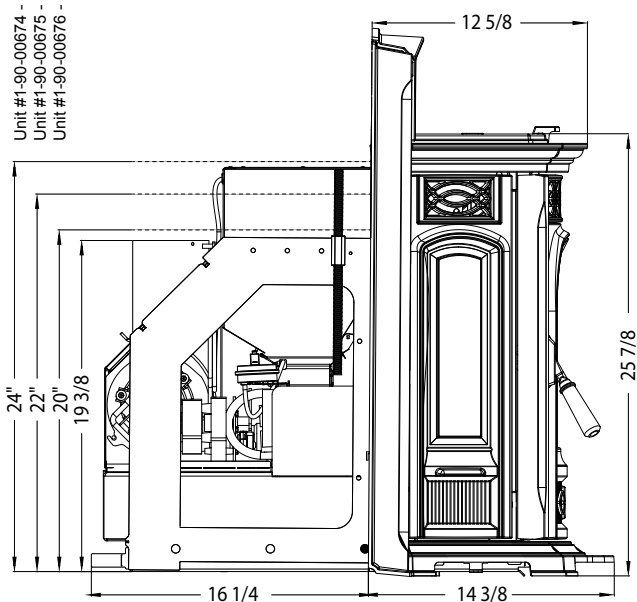

Weight	450 lbs.
Blower	180 cfm
Hopper Capacity	57 lbs. (24" hopper #1-90-00674)
Fuel	Wood Pellets
Outside Air Size	3 inches
Fuse Rating	6 amp
BTU Range	0 to 42,000
Feed Rate	.75 lbs./hr. on minimum(on maintenance) 5 lbs./ hr. on maximum
Vent Size	4 inch Pellet Vent Pipe, standard, 3 inch Pellet Vent Pipe, option
Maximum Wattage	440 Watts (Start cycle and test)
Start Cycle Wattage	340 Watts
Normal Run Wattage	255 Watts

Accentra Insert Wiring Diagram

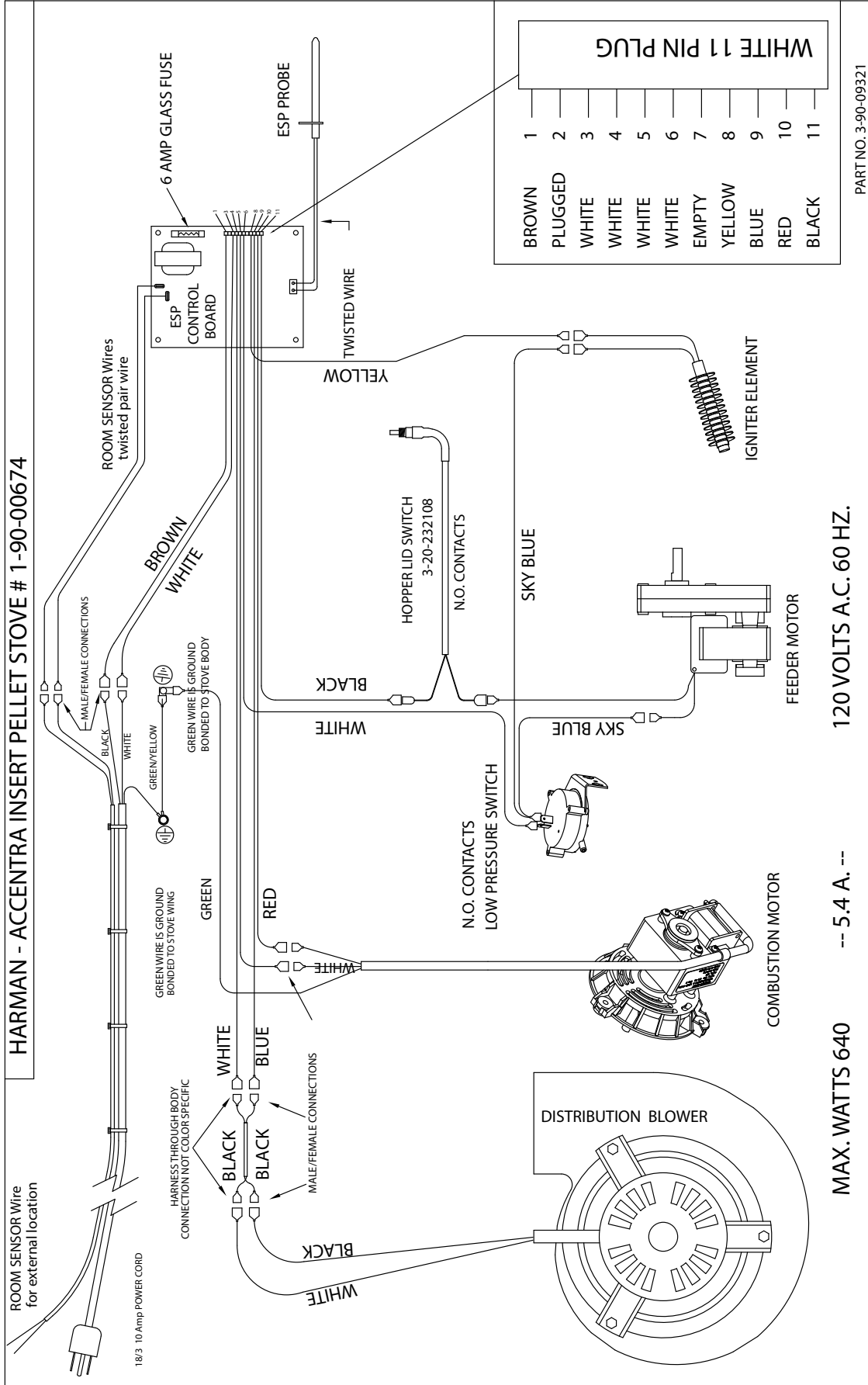

Hearth & Home Technologies LIMITED LIFETIME WARRANTY

Hearth & Home Technologies, on behalf of its hearth brands ("HHT"), extends the following warranty for HHT gas, wood, pellet, coal and electric hearth appliances that are purchased from an HHT authorized dealer.

WARRANTY COVERAGE:

HHT warrants to the original owner of the HHT appliance at the site of installation, and to any transferee taking ownership of the appliance at the site of installation within two years following the date of original purchase, that the HHT appliance will be free from defects in materials and workmanship at the time of manufacture. After installation, if covered components manufactured by HHT are found to be defective in materials or workmanship during the applicable warranty period, HHT will, at its option, repair or replace the covered components. HHT, at its own discretion, may fully discharge all of its obligations under such warranties by replacing the product itself or refunding the verified purchase price of the product itself. The maximum amount recoverable under this warranty is limited to the purchase price of the product. This warranty is subject to conditions, exclusions and limitations as described below.

WARRANTY PERIOD:

Warranty coverage begins on the date of original purchase. In the case of new home construction, warranty coverage begins on the date of first occupancy of the dwelling or six months after the sale of the product by an independent, authorized HHT dealer/ distributor, whichever occurs earlier. The warranty shall commence no later than 24 months following the date of product shipment from HHT, regardless of the installation or occupancy date. The warranty period for parts and labor for covered components is produced in the following table.

The term "Limited Lifetime" in the table below is defined as: 20 years from the beginning date of warranty coverage for gas appliances, and 10 years from the beginning date of warranty coverage for wood, pellet, and coal appliances. These time periods reflect the minimum expected useful lives of the designated components under normal operating conditions.

Warranty Period		HHT Manufactured Appliances and Venting							Components Covered
Parts	Labor	Gas	Wood	Pellet	EPA Wood	Coal	Electric	Venting	
1 Year		X	X	X	X	X	X	X	All parts and material except as covered by Conditions, Exclusions, and Limitations listed
2 years				X	X	X			Igniters, electronic components, and glass
		X	X	X	X	X			Factory-installed blowers
				X					Molded refractory panels
3 years				X					Firepots and burnpots
5 years	1 year			X	X				Castings and baffles
7 years	3 years		X	X	X				Manifold tubes, HHT chimney and termination
10 years	1 year	X							Burners, logs and refractory
Limited Lifetime	3 years	X	X	X	X	X			Firebox and heat exchanger
90 Days		X	X	X	X	X	X	X	All replacement parts beyond warranty period

See conditions, exclusions, and limitations on next page.

WARRANTY CONDITIONS:

- This warranty only covers HHT appliances that are purchased through an HHT authorized dealer or distributor. A list of HHT authorized dealers is available on the HHT branded websites.
- This warranty is only valid while the HHT appliance remains at the site of original installation.
- This warranty is only valid in the country in which the HHT authorized dealer or distributor that sold the appliance resides.
- Contact your installing dealer for warranty service. If the installing dealer is unable to provide necessary parts, contact the nearest HHT authorized dealer or supplier. Additional service fees may apply if you are seeking warranty service from a dealer other than the dealer from whom you originally purchased the product.
- Check with your dealer in advance for any costs to you when arranging a warranty call. Travel and shipping charges for parts are not covered by this warranty.

WARRANTY EXCLUSIONS:

This warranty does not cover the following:

- Changes in surface finishes as a result of normal use. As a heating appliance, some changes in color of interior and exterior surface finishes may occur. This is not a flaw and is not covered under warranty.
- Damage to printed, plated, or enameled surfaces caused by fingerprints, accidents, misuse, scratches, melted items, or other external sources and residues left on the plated surfaces from the use of abrasive cleaners or polishes.
- Repair or replacement of parts that are subject to normal wear and tear during the warranty period. These parts include: paint, wood, pellet and coal gaskets, firebricks, grates, flame guides, batteries and the discoloration of glass.
- Minor expansion, contraction, or movement of certain parts causing noise. These conditions are normal and complaints related to this noise are not covered by this warranty.
- Damages resulting from: (1) failure to install, operate, or maintain the appliance in accordance with the installation instructions, operating instructions, and listing agent identification label furnished with the appliance; (2) failure to install the appliance in accordance with local building codes; (3) shipping or improper handling; (4) improper operation, abuse, misuse, continued operation with damaged, corroded or failed components, accident, or improperly/incorrectly performed repairs; (5) environmental conditions, inadequate ventilation, negative pressure, or drafting caused by tightly sealed constructions, insufficient make-up air supply, or handling devices such as exhaust fans or forced air furnaces or other such causes; (6) use of fuels other than those specified in the operating instructions; (7) installation or use of components not supplied with the appliance or any other components not expressly authorized and approved by HHT; (8) modification of the appliance not expressly authorized and approved by HHT in writing; and/or (9) interruptions or fluctuations of electrical power supply to the appliance.
- Non-HHT venting components, hearth components or other accessories used in conjunction with the appliance.
- Any part of a pre-existing fireplace system in which an insert or a decorative gas appliance is installed.
- HHT's obligation under this warranty does not extend to the appliance's capability to heat the desired space. Information is provided to assist the consumer and the dealer in selecting the proper appliance for the application. Consideration must be given to appliance location and configuration, environmental conditions, insulation and air tightness of the structure.

This warranty is void if:

- The appliance has been over-fired or operated in atmospheres contaminated by chlorine, fluorine, or other damaging chemicals. Over-firing can be identified by, but not limited to, warped plates or tubes, rust colored cast iron, bubbling, cracking and discoloration of steel or enamel finishes.
- The appliance is subjected to prolonged periods of dampness or condensation.
- There is any damage to the appliance or other components due to water or weather damage which is the result of, but not limited to, improper chimney or venting installation.

LIMITATIONS OF LIABILITY:

- The owner's exclusive remedy and HHT's sole obligation under this warranty, under any other warranty, express or implied, or in contract, tort or otherwise, shall be limited to replacement, repair, or refund, as specified above. In no event will HHT be liable for any incidental or consequential damages caused by defects in the appliance. Some states do not allow exclusions or limitation of incidental or consequential damages, so these limitations may not apply to you. This warranty gives you specific rights; you may also have other rights, which vary from state to state. EXCEPT TO THE EXTENT PROVIDED BY LAW, HHT MAKES NO EXPRESS WARRANTIES OTHER THAN THE WARRANTY SPECIFIED HEREIN. THE DURATION OF ANY IMPLIED WARRANTY IS LIMITED TO DURATION OF THE EXPRESSED WARRANTY SPECIFIED ABOVE.

Addendum

Minimizing Smoke During Loss of Power Using Battery Back-up

Harman® strongly recommends installing battery back-up to minimize entry of smoke into the room in the event of power loss.

Your pellet/biomass burning appliance relies on a combustion blower to remove exhaust. A power failure will cause the combustion blower to stop. This may lead to exhaust seeping into the room. Vertical rise in the venting may provide natural draft. It is, however, no guarantee against leakage.

There are two Harman® approved battery back-up options for your appliance:

Uninterruptible Power Supply (UPS) UPS battery back-ups are available online or at computer and office equipment stores. Your Harman® appliance with Rev E or later software available beginning in November 2010 may be plugged directly into a Harman® approved UPS:

- The APC (American Power Conversion) model #BE750G and the TrippLite model INTERNET750U are tested and approved. Other brands or models may not be compatible.

When power is lost, a fully charged UPS will power a safe, combustion blower only shut-down. Your appliance will pulse the blower every few seconds to clear exhaust until the fire is out. **NOTE: The UPS provides safe shut-down only. It is not intended for continued operation.**

Your appliance will recognize when power is restored. What happens depends on ESP temperature and whether it is equipped with automatic ignition:

- In **“Automatic” setting**, units equipped with automatic ignition will respond to the set point and ESP temperature and resume normal operation.
- In **“Manual” setting** or for units without automatic ignition:
 - If the ESP is cool, the appliance will remain shut down.
 - If the fire is out and the ESP is still warm, the feeder may restart. Since the fire is out, the ESP temperature will not rise. The unit will then shut-down, and may flash a six-blink status error. (See ESP error codes)
 - If the fire is still burning, it will resume normal operation.

Contact your dealer if you have questions about UPS compatibility with your appliance.

Harman® Surefire 512H Battery Back-up The 512H connects to a 12 volt deep cycle battery that will run your appliance for up to eight (8) hours. It includes a trickle charge feature that keeps your battery charged when power is available. **NOTE: If the power is out for longer than battery life, smoke leakage may still occur unless your stove has been safely shut down.**

CAUTION! Always keep appliance doors and hopper lid closed and latched during operation and during power failures to minimize risk of smoke or burn-back.

CAUTION! Use only Harman® approved battery back-up devices. Other products may not operate properly, can create unsafe conditions or damage your appliance.

Fuel and Fuel Storage

Pellet fuel quality can fluctuate from manufacturer to manufacturer, and even from bag to bag. Hearth & Home Technologies recommends using only fuel that is certified by the Pellet Fuels Institute (PFI).

Fuel Material

- Made from sawdust and/or other wood by-products
- Shelled field corn (when mixed with wood pellets)
- Source material typically determines ash content

Higher Ash Content Material

- Hardwoods with high mineral content
- Bark and leaves as source material
- "Standard" grade pellets, corn and other biomass

Lower Ash Content Material

- Softwood; pine, fir, etc.
- Materials with lower mineral content
- "Premium" grade pellets

Shelled field corn

- Must be 15% moisture content or less
- Must be clean and free of debris
- Must be mixed with wood pellets. (Up to 50%)
- Stalk parts, excessive fines and cob remnants may cause feed system jams or blockage

CAUTION! Do not burn fuel that contains an additive; (such as soybean oil)

- May cause hopper fire
- Damage to product may result

Read the list of ingredients on the packaging. If you are buying field corn, the only ingredient listed should be field corn.

WARNING! Risk of Chemical Poisoning!

Do **NOT** burn treated seed corn

- Chemical pesticides are harmful or fatal if swallowed
- Burning treated seed corn will void the product warranty

Clinkers

Minerals and other non-combustible materials, like sand, will turn into a hard glass-like substance when heated.

Trees from different areas will vary in mineral content. For this reason, some fuels will produce more clinkers than others.

Moisture

Always burn dry fuel. Burning fuel with high moisture content takes energy to dry and tends to cool the appliance thus, robbing heat from your home. Damp pellet fuel could turn back into sawdust which does not flow properly through the feed system.

Size

- Pellets are either 1/4 inch or 5/16 inch (6-8mm) in diameter
- Length should be no more than 1-1/2 inches (38mm)
- Pellet length can vary from lot to lot from the same manufacturer

Performance

- Higher ash content requires more frequent maintenance.
- "Premium" grade pellets will produce the highest heat output.
- Burning pellets longer than 1-1/2 inches (38mm) can cause inconsistent feeding and/or ignition.

We recommend that you buy fuel in multi-ton lots whenever possible. However, we do recommend trying different brands prior to purchasing multi-ton lots, to ensure your satisfaction.

CAUTION! Tested and approved for use with wood pellets and a mixture of shelled field corn and wood pellets ONLY. Burning of any other fuel will void your warranty.

When changing from wood pellets to a corn/pellet mixture, the FEED ADJUSTER will likely need adjusted to a lower setting. When under maximum demand, ensure there is no unburned fuel being pushed into the ash pan.

Storage

- Wood pellets should be left in their original sealed bag until ready to use, to prevent moisture.
- Shelled corn should be stored in a tightly sealed container to prevent moisture and to deter pests
- Do not store fuel within the specified clearance areas, or in a location that will interfere with routine cleaning and maintenance procedures.

CAUTION

Tested and approved for use with wood pellets and a mixture of shelled field corn and wood pellets ONLY. Burning of any other fuel will void your warranty.

NOTICE

Hearth & Home Technologies is not responsible for stove performance or extra maintenance required as a result of using fuel with higher ash or mineral content.

Addendum for Burning Corn and Pellet Fuel Mixture

Harman pellet burning, free-standing stoves and inserts have been tested to ASTM E1509 for burning shelled corn in a mixture with wood pellets. The listing approves up to a 50% corn and 50% pellet mixture. Different mixtures of corn will have distinctively different burn characteristics depending upon moisture content and variety. The operator should closely monitor the stove's operation when burning a new corn/pellet mixture or a different variety of corn, and make any necessary adjustments to feed rate. Since corn is typically higher in ash and moisture content, cleaning and ash removal will be needed more frequently.

Operation in Stove Temp mode

Set feed adjuster to # 3. Set temperature knob to #3, Turn mode selector knob onto "Stove Temp" mode. After the fire has lit, watch that the fuel does not feed too fast that it pushes the red glowing fuel bed off of the burn pot grate. If it does, lower the feed adjuster setting or use a lower percentage of corn in the mixture. After the stove has burned for 10 minutes and the entire fuel bed is burning, the feed adjuster and temperature knobs may be adjusted for higher heat output if desired. Maximum feed has been reached when the fire bed is about ½ to 1 inch from the end of the burn pot. Settings will vary with different types, moisture levels and mix ratios of corn. If you are having difficulty burning a 50% corn / 50% wood pellet mixture, try a lower percentage of corn.

Operation in Room Temp mode

Set feed adjuster to # 2 or # 3. Set temperature knob to desired amount. Turn mode selector knob onto "Room Temp" mode. After the fire has lit, watch that the fuel does not feed too fast that it pushes the red glowing fuel bed off of the burn pot grate. After the stove has burned for 10 minutes and the entire fuel bed is burning, the feed adjuster may be set to a higher output level if desired. Maximum feed has been reached when the fire bed is about ½ to 1 inch from the end of the burn pot. It is recommended that after burning at the desired settings, turn the stove off and allow it to cool, then turn it back on in "Room Temp" mode and watch the stove restart and verify correct operation. Settings will vary with different types, moisture levels and mix ratios of corn. If you are having difficulty burning a 50% corn 50% wood pellet mixture, try a lower percentage of corn.

Changes to Maintenance Schedule

Wood pellets average around 6% moisture content or less. Corn will be 14 or 15% moisture. With more moisture in the fuel, more maintenance will be incurred. Burn pot scraping may need to be done once per day. The ash pan will fill more quickly and may need emptied weekly. Most importantly, remove the burn pot cleanout cover weekly to clean the air passage and the igniter element. Excessive buildup on the igniter may lead to shortened igniter life.

Venting Consideration: Check with your venting manufacturer regarding possible exclusions when a mixture of corn and pellets is burned.

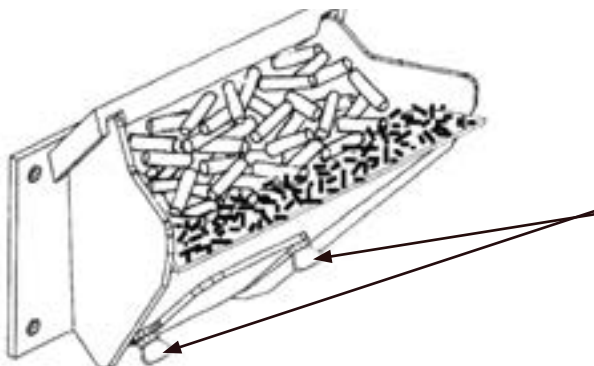

Loosen these two wing screws for access to clean the air passage and igniter.

At Harman, we build each product to a standard, not a price. This powerful heating appliance boasts uncompromising attention to detail and helps preserve our planet by using environmentally responsible fuels.



(Signature of Boxer)

Your premium quality hearth product designed and assembled by the experienced and skilled members at Harman in Halifax, PA, USA.

HARMAN[®]

BUILT TO A STANDARD, NOT A PRICE

Proudly Printed On 100% Recycled Paper

