

Owner's Manual

Operation & Care

This unit has been retired. Service parts pages within have been removed. For replacement parts, please refer to the individual service parts list located on the brand website.

INSTALLER: Leave this manual with party responsible for use and operation.
OWNER: Retain this manual for future reference.



Contact your dealer with questions on installation, operation, or service.

NOTICE: DO NOT DISCARD THIS MANUAL



QUADRA-FIRE®

PELLET BURNING STOVE

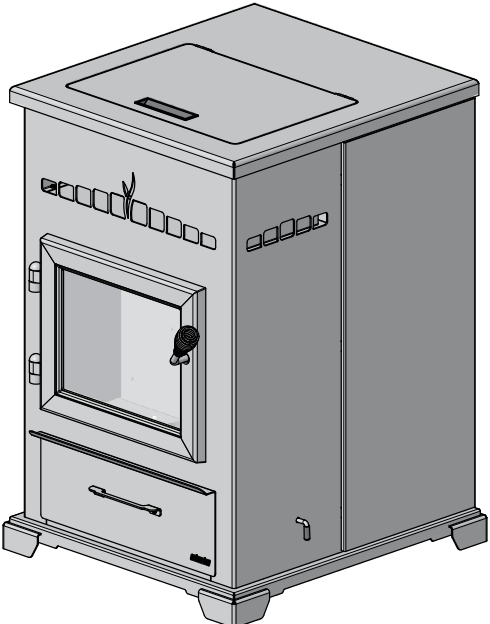
**MODEL NUMBER:
CAB50-C**



WARNING





If the information in these instructions is not followed exactly, a fire could result causing property damage, personal injury, or death.

- Do not store or use gasoline or other flammable vapors and liquids in the vicinity of this or any other appliance.
- Do not over fire - If appliance or chimney connector glows, you are over firing. Over firing will void your warranty.
- Comply with all minimum clearances to combustibles as specified.

Failure to comply may cause house fire.

WARNING



HOT SURFACES!
Glass and other surfaces are hot during operation AND cool down.

Hot glass will cause burns.

- Do not touch glass until it is cooled
- NEVER allow children to touch glass
- Keep children away
- CAREFULLY SUPERVISE children in same room as fireplace.
- Alert children and adults to hazards of high temperatures
- **High temperatures may ignite clothing or other flammable materials.**
- Keep clothing, furniture, draperies and other flammable materials away.

CAUTION



Check building codes prior to installation.

- Installation MUST comply with local, regional, state and national codes and regulations.
- Consult local building, fire officials or authorities having jurisdiction about restrictions, installation inspection, and permits.

NOTE: To obtain a French translation of this manual, please contact your dealer or visit www.quadrafire.com.

REMARQUE : Pour obtenir une traduction française de ce manuel, s'il vous plaît contacter votre revendeur ou visitez www.quadrafire.com.

CAUTION



Tested and approved for wood pellets, Burning of any other type of fuel voids your warranty.

Installation and service of this appliance should be performed by qualified personnel. Hearth & Home Technologies recommends HHT Factory Trained or NFI certified professionals.



Congratulations

and Welcome to the Quadra-Fire Family!

NOTE: Clearances may only be reduced by means approved by the regulatory authority having jurisdiction

A. Sample of Serial Number / Safety Label

LOCATION: Back of appliance

Model Name

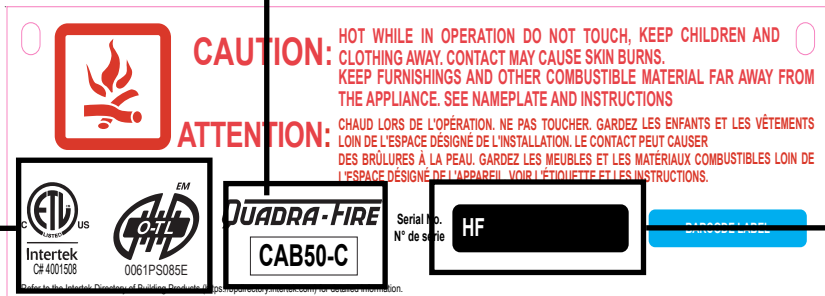

Test Lab and Report Number

Serial Number

Listed Solid Fuel Room Heater/Pellet Type. Also suitable for Mobile Home Installation. This appliance has been tested and listed for use in Manufactured Homes in accordance with QAR 814-23-9000 through 814-23-909.

Appareil de chauffage de combustible solide/de type de bûchettes. Appareil de chauffage dans les maisons mobiles. Cet appareil a été testé et enregistré pour l'usage dans les Maisons Mobiles en accord avec QAR 814-23-9000 jusqu'à 814-23-909.

Certified to: ASTM STD E1509; Certified to: ULC STD S627 Room Heating Pellet Burning Type, (UM) 84-HUD FOR USE ONLY WITH PELLETED WOOD. Do not use any other type of fuel. Intertek-Test Laboratories has determined that this appliance complies with Canadian Standards Association (CSA) B415.1 and Title 40 of the U.S. Code of Federal Regulations, Part 60, SubPart AAA. Input Rating: 49,869 Btu/hr. Electrical Rating: 115 VAC, 60 Hz, Start 5.1 Amps, Run 3.0 AMPS. Route power cord away from unit. Do not route cord under or in front of appliance. Do not obstruct the space beneath the heater.

Certifié à : ASTM E1509; Certifié à : ULC S627 Room Heating Pellet Burning Type, (UM) 84-HUD POUR USAGE AVEC LES BOULETTES DE BOIS. N'utiliser aucun autre genre de combustible. Intertek-Test Laboratories a déterminé que cet appareil se conforme avec la norme de l'Association Canadienne de normalisation (CSA) B415.1 ainsi que le Titre 40 du Code Fédéral de Régulations des États-Unis, partie 60, sous-partie AAA. Puissance de Rendement : 49,869 Btu/hr. Puissance Électrique : 115 VAC, 60 Hz, Début 5.1 Amps, Courir 3.0 Amps. Eloignez le fil électrique de l'appareil. Ne pas faire passer le fil électrique au dessus ou en dessous de l'appareil. Ne pas bloquer l'espace au dessous de l'appareil.

DANGER: Risk of electrical shock. Disconnect power supply before servicing. Replace glass only with 5mm ceramic available from your dealer. To start, set thermostat above room temperature, the stove will light automatically. To shutdown, set thermostat to below room temperature. For further instruction refer to owner's manual.

DANGER: Il y a risque de décharge électrique. Déconnectez le fil électrique de la prise de contact avant le service. Remplacez la vitre seulement avec une vitre céramique 5 mm disponible chez votre fournisseur. Pour allumer, monter la température du thermostat au-dessus de la température de la pièce, le poêle s'allumera automatiquement. Pour éteindre, descendre la température du thermostat en dessous de la température de la pièce. Pour des instructions supplémentaires, référez vous au manuel du propriétaire. Réglez la température de la pièce et la porte des cendres fermées hermétiquement durant l'opération.

PREVENT HOUSE FIRES
Install and use only in accordance with manufacturer's installation and operating instructions. Contact local building or fire officials about restrictions and inspection in our area.

PREVENTION DES FEUX DE MAISON
Installez et utilisez en accord avec les instructions d'installation et d'opération du fabricant. Contactez le bureau de la construction ou les officiels locaux au sujet des restrictions et des inspections d'installation dans votre voisinage. Ne pas obtenir l'estimation de la construction de la maison sans l'avis de votre architecte.

WARNING - FOR MOBILE HOMES: Do not install appliance in a sleeping room. An outside combustion air inlet must be provided. The structural integrity of the mobile home floor, ceiling and walls must be maintained.

AVIS - Pour les Maisons Mobiles: Ne pas installer dans une chambre à coucher. Un tuyau extérieur de combustion d'air doit être installé et ne pas être obstrué lorsque l'appareil est en usage. La structure intégrale du plancher, du plafond et des murs de la maison mobile doit être maintenue intacte.

Refer to manufacturer's instructions and local codes for precautions required for passing chimney through a combustible wall or ceiling. Inspect and clean vent system frequently in accordance with manufacturer's instructions. **DO NOT CONNECT THIS UNIT TO CHIMNEY SERVING ANOTHER APPLIANCE.** Use a 3" or 4" diameter type "L" or "PL" venting system.

Référez-vous aux instructions du fabricant et aux codes locaux pour les précautions requises pour passer une cheminée à travers un mur ou un plafond combustibles, et les compensations maximums. Inspectez et nettoyez la cheminée fréquemment. Ne pas connecter cet appareil à une cheminée servant un autre appareil. Utilisez un système de ventilation "L" ou "PL" diamètre 76mm ou 102mm.

MINIMUM CLEARANCES TO COMBUSTIBLES / ESPACES LIBRES MINIMUM DES MATÉRIEAUX COMBUSTIBLES:

A	Back Wall / Mur Arrière	2 in [51mm]
B	Side Wall / Mur De Côté	14 in [356mm]
CORNER INSTALLATION / INSTALLATION DU COIN :		
C	Side Wall / Mur De Côté	2 in [51mm]
VERTICAL 3 in. - 3 in. ADAPTER KIT (PART TPVNT-5) INSTALLATION:		
UN ASSEMBLAGE POUR ADAPTEUR 3-3 in (76-76mm) POUR INSTALLATION VERTICALE:		
D	Pipe to Back Wall / Un Tuyau Mur Arrière	1 in [25mm]
E	Side Wall / Mur De Côté	14 in [356mm]
F	Back Wall / Mur Arrière	6.25 in [159mm]
CORNER INSTALLATION WITH VERTICAL ADAPTER KIT:		
INSTALLATION DU COIN AVEC UN ASSEMBLAGE D'ADAPTEUR VERTICAL:		
G	Side Wall / Mur De Côté	2 in [51mm]
ALCOVE INSTALLATION / INSTALLATION DE L'ALCÔVE:		
Min. Alcove Height / Une hauteur minimum de falçave		56.75 in [1441mm]
Min. Alcove Side Wall / Une hauteur minimum mur de côté de falçave		14 in [356mm]
Min. Alcove Width / Une épaisseur minimum mur de côté de falçave		53 in [1346mm]
Max. Mantle Depth / La profondeur maximum de la manteau de cheminée		48 in [1219mm]
Max. Mantle Depth / Profondeur maximum de la manteau de cheminée		36 in [914mm]
Top of Unit to Combustibles / Vue du haut des matériaux combustibles		21 in [533mm]

FLOOR PROTECTION / PROTECTION DU SOL
Floor protector must be non-combustible material, extending beneath heater and to the front/sides/rear as indicated. Measure front distance (I) from the surface of the glass door.

Le poêle doit être placé sur une assise non combustible s'étendant tout autour de lui, comme les schémas l'indiquent. Mesurez la distance du devant (I) de la surface de la porte vitrée.

USA
G = 2 in
H* = 2 in
I = 6 in

CANADA
G = 203 mm
H* = 51 mm
I = 152 mm

*Non-combustible floor protection must extend 2 inches (51mm) beneath the flue pipe when installed with horizontal venting or under the Top Vent Adapter with vertical installation. **RECOMMENDED IN USA; REQUIRED IN CANADA.**

*Un protecteur incombustible de plancher doit s'étendre 2 inches (51mm) sous le conduit de cheminée pour une installation de ventilation horizontale ou sous un adaptateur de ventilation de dessus pour une installation verticale. **ÉTATS-UNIS - RECOMMANDÉ; CANADA - REQUIS.**

Manufactured by: Fabriqué par: **HEARTH-HOME TECHNOLOGIES**
352 Mountain House Road
Haitfall, Pa 17032
www.quadrafire.com

This heater is in a manner inconsistent with the operating instructions in the owner's manual.

U.S. ENVIRONMENTAL PROTECTION AGENCY
Certified to comply with 2020 particulate emission standards at 1.0 g/hr EPA method 289 and ASTM 2779 using premium wood pellets.

DO NOT REMOVE THIS LABEL / NE PAS ENLEVER L'ÉTIQUETTE

2021 2022 2023 JAN FEB MAR APR MAY JUN JUL AUG SEP OCT NOV DEC

7074-8041

Manufacturer Date

Safety Alert Key:



- **DANGER!** Indicates a hazardous situation which, if not avoided will result in death or serious injury.
 - **WARNING!** Indicates a hazardous situation which, if not avoided could result in death or serious injury.
 - **CAUTION!** Indicates a hazardous situation which, if not avoided, could result in minor or moderate injury.
 - **NOTICE:** Indicates practices which may cause damage to the appliance or to property.
-

TABLE OF CONTENTS

A. Sample of Serial Number / Safety Label	2	3 Maintenance and Service	
B. Warranty Policy	4	A. Proper Shutdown Procedure	15
C. Quick Start Guide.	6	B. Quick Reference Maintenance Chart.	15
1 Listing and Code Approvals		C. General Maintenance.	16
A. Appliance Safety Certification	7	D. High Ash Fuel Content Maintenance	20
B. Appliance Emissions Certification	7	E. Soot or Creosote Fire.	20
C. BTU & Efficiency Specifications.	7	4 Troubleshooting Guide	21
D. Glass Specifications.	8	5 Service Parts Replacement	
E. Electrical Rating (on high)	8	A. Side Curtain Replacement.	24
F. Mobile Home Approved	8	B. Convection Blower Replacement.	24
G. Sleeping Room	8	C. Exhaust Blower Replacement	25
H. California - Prop65.	8	D. Snap Disc #1, #2, #3 Replacement	25
2 Operating Instructions		E. Igniter Replacement.	26
A. Fire Safety	9	F. Baffle Replacement	26
B. Non-Combustible Materials	9	G. Glass Replacement	27
C. Combustible Materials	9	6 Reference Materials	
D. Fuel Material and Fuel Storage	9	A. Component Functions	28
E. General Operating Information.	10	B. Component Locations	30
F. Before Your First Fire	10	C. Maintenance and Service Log	31
G. Hopper Lid and Hopper Switch	11		
H. Starting Your First Fire	11		
I. Fire Characteristics	12		
J. Feed Rate Adjustment Instructions.	12		
K. Ignition Cycles	12		
L. Clear Space	13		
M. Thermostat Operation	13		
N. Frequently Asked Questions	14		

→ = Contains updated information

B. Warranty Policy

Hearth & Home Technologies LIMITED LIFETIME WARRANTY

Hearth & Home Technologies, on behalf of its hearth brands (“HHT”), extends the following warranty for HHT gas, wood, pellet and electric hearth appliances that are purchased from an HHT authorized dealer.

WARRANTY COVERAGE:

HHT warrants to the original owner of the HHT appliance at the site of installation, and to any transferee taking ownership of the appliance at the site of installation within two years following the date of original purchase, that the HHT appliance will be free from defects in materials and workmanship at the time of manufacture. After installation, if covered components manufactured by HHT are found to be defective in materials or workmanship during the applicable warranty period, HHT will, at its option, repair or replace the covered components. HHT, at its own discretion, may fully discharge all of its obligations under such warranties by replacing the product itself or refunding the verified purchase price of the product itself. The maximum amount recoverable under this warranty is limited to the purchase price of the product. This warranty is subject to conditions, exclusions and limitations as described below.

WARRANTY PERIOD:

Warranty coverage for consumers begins at the date of installation. In the case of new home construction, warranty coverage begins on the date of first occupancy of the dwelling or six months after the sale of the product by an independent, authorized HHT dealer/distributor, whichever occurs earlier. However, the warranty shall commence no later than 24 months following the date of product shipment from HHT, regardless of the installation or occupancy date. The warranty period for parts and labor for covered components is produced in the following table.

The term “Limited Lifetime” in the table below is defined as: 20 years from the beginning date of warranty coverage for gas appliances, and 10 years from the beginning date of warranty coverage for wood and pellet appliances. These time periods reflect the minimum expected useful lives of the designated components under normal operating conditions.

Warranty Period		HHT Manufactured Appliances and Venting					
Parts	Labor	Gas	Pellet	Wood	Electric	Venting	Components Covered
1 Year		X	X	X	X	X	All parts including handles, external enameled components and other material except as covered by Conditions, Exclusions, and Limitations listed
2 years			X	X			Igniters, Auger Motors, Electronic Components, and Glass
		X					Electrical components limited to modules, remotes/wall switches, valves, pilots, blowers, junction boxes, wire harnesses, transformers and lights (excluding light bulbs)
		X		X			Molded Refractory Panels, Glass Liners
3 years			X				Firepots, burnpots, mechanical feeders/auger assemblies
5 years	1 year	X					Vent Free Burners, Vent Free Logs
			X	X			Castings, Medallions and Baffles
6 years	3 years			X			Catalyst - Limitations Listed
7 years	3 years		X	X			Manifold tubes, HHT Chimney and Terminations
10 years	1 year	X					Burners, logs and refractory
Limited Lifetime	3 years	X	X	X			Firebox and heat exchanger, FlexBurn® System (engine, inner cover, access cover and fireback)
1 Year	None	X	X	X	X	X	All replacement parts beyond warranty period

See conditions, exclusions and limitations on the next page

WARRANTY CONDITIONS:

- This warranty only covers HHT appliances that are purchased through an HHT authorized dealer or distributor. A list of HHT authorized dealers is available on the HHT branded websites.
- This warranty is only valid while the HHT appliance remains at the site of original installation.
- This warranty is only valid in the country in which the HHT authorized dealer or distributor that sold the appliance resides.
- Contact your installing dealer for warranty service. If the installing dealer or distributor is unable to provide necessary parts, contact the nearest HHT authorized dealer or supplier. Additional service fees may apply if you are seeking warranty service from a dealer other than the dealer from whom you originally purchased the product.
- Check with your dealer in advance for any costs to you when arranging a warranty call. Travel and shipping charges for parts are not covered by this warranty.
- Limited Catalyst Warranty
 - o For wood burning products containing a catalyst, the catalyst will be warranted for a six-year period to the original purchaser at the site of original installation. The purchaser must provide the name, address, and telephone number of the location where the product is installed, proof of original purchase date, date of failure, and any relevant information regarding the failure of the catalyst.

WARRANTY EXCLUSIONS:

This warranty does not cover the following:

- Changes in surface finishes as a result of normal use. As a heating appliance, some changes in color of interior and exterior surface finishes may occur. This is not a flaw and is not covered under warranty.
- Damage to printed, plated, or enameled surfaces caused by fingerprints, accidents, misuse, scratches, melted items, or other external sources and residues left on the plated surfaces from the use of abrasive cleaners or polishes.
- Repair or replacement of parts that are subject to normal wear and tear during the warranty period are not covered. These parts include: paint, wood and pellet gaskets, firebricks, grates, flame guides, batteries and the discoloration of glass.
- Expansion, contraction, or movement of certain parts causing noise. These conditions are normal and complaints related to this noise are not covered by this warranty.
- Damages resulting from: (1) failure to install, operate, or maintain the appliance in accordance with the installation instructions, operating instructions, and listing agent identification label furnished with the appliance; (2) failure to install the appliance in accordance with local building codes; (3) shipping or improper handling; (4) improper operation, abuse, misuse, continued operation with damaged, corroded or failed components, accident, or improperly/incorrectly performed repairs (5) environmental conditions, inadequate ventilation, negative pressure, or drafting caused by tightly sealed constructions, insufficient make-up air supply, or handling devices such as exhaust fans or forced air furnaces or other such causes; (6) use of fuels other than those specified in the operation instructions; (7) installation or use of components not supplied with the appliance or any other components not expressly authorized and approved by HHT; (8) modification of the appliance not expressly authorized and approved by HHT in writing; and/or (9) interruptions or fluctuations of electrical power supply to the appliance.
- Non-HHT venting components, hearth connections or other accessories used in conjunction with the appliance.
- Any part of a pre-existing fireplace system in which an insert or a decorative gas appliance is installed.
- HHT's obligation under this warranty does not extend to the appliance's capability to heat the desired space. Information is provided to assist the consumer and the dealer in selecting the proper appliance for the application. Consideration must be given to the appliance location and configuration, environmental conditions, insulation and air tightness of the structure.

This warranty is void if:

- The appliance has been over-fired, operated in atmospheres contaminated by chlorine, fluorine, or other damaging chemicals. Over-firing can be identified by, but not limited to, warped plates or tubes, deformation/warping of interior cast iron structure or components, rust colored cast iron, bubbling, cracking and discoloration of steel or enamel finishes.
- The appliance is subjected to prolonged periods of dampness or condensation.
- There is any damage to the appliance or other components due to water or weather damage which is the result of, but not limited to, improper chimney or venting installation.

LIMITATIONS OF LIABILITY

- The owner's exclusive remedy and HHT's sole obligation under this warranty, under any other warranty, express or implied, or in contract, tort or otherwise, shall be limited to replacement, repair, or refund, as specified above. In no event will HHT be liable for any incidental or consequential damages caused by defects in the appliance. Some states do not allow exclusions or limitation of incidental or consequential damages, so these limitations may not apply to you. This warranty gives you specific rights; you may also have other rights, which vary from state to state. EXCEPT TO THE EXTENT PROVIDED BY LAW, HHT MAKES NO EXPRESS WARRANTIES OTHER THAN THE WARRANTY SPECIFIED HEREIN. THE DURATION OF ANY IMPLIED WARRANTY IS LIMITED TO DURATION OF THE EXPRESSED WARRANTY SPECIFIED ABOVE.

C. Quick Start Guide

QUICK START GUIDE

Before you plug in this appliance, follow these instructions

Remove hang tags from the door glass. Clean the glass. Remove the hardware pack and desiccant bag from the firebox area before your first fire.

Turn the thermostat to off.

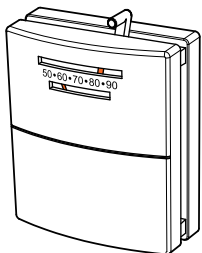

1

Add pellets to the hopper and close the lid.

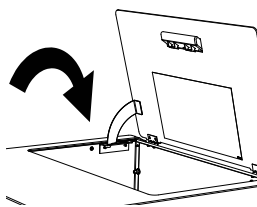

2

Open the firebox door and make sure the baffles are in place.



3

If the feed tube is empty or this is the first fire, add a handful of pellets to the fire pot.

*Do not add extra fuel to the fire pot if the feed tube has already been primed. Overfilling the fire pot will cause smoky start-ups.

4

Close the firebox door and plug the power cord into the wall receptacle.

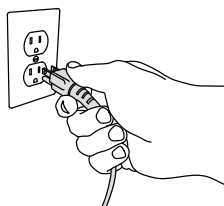

5

Turn the thermostat on.

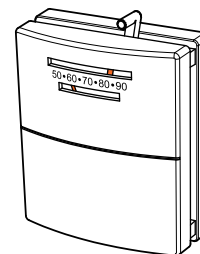

6

The stove will feed pellets for a minute and stop. Once a fire starts, the feed cycle will resume.

NOTE: Allow 5 minutes for ignition to take place.

7

If the fire dies out after a few minutes of operation it will be necessary to push the reset button to add more fuel.

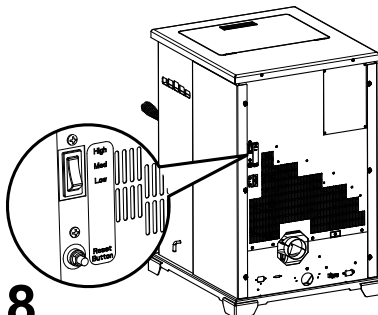

8

Once a fire has been established in the unit, leave the unit burning on the "high" setting for 30 minutes to allow the paint to cure.

NOTE: Odors and vapors will be released during this process.

Open windows in the room for ventilation

9

After 30 minutes have passed, turn the thermostat off and allow the unit to cool completely. Open the door and clean the fire pot according to the cleaning instructions found inside the hopper lid or owners manual. Close the door and set the thermostat to a desired temperature. Unit is now ready to resume normal operation.

10

1 Listing and Code Approvals

A. Appliance Safety Certification

Model:	CAB50-C
Laboratory:	Intertek
Report Number:	100358108PRT-005
Type:	Solid Fuel Room Heater/Pellet Fuel Burning Type
Standard:	ASTM E1509-04 and ULC S627-00 Room Heater Pellet Fuel Burning type and (UM) 84-HUD, Mobile Home Approved.

B. Appliance Emissions Certification

Model:	CAB50-C
Laboratory:	OMNI Test Laboratories, Inc.
Report Number:	0061PS085E
Standard:	Method 28R, ASTM E1509-04 and ASTM 2779
Can be found at:	www.quadrafire.com/about-us/epa-certification

C. BTU & Efficiency Specifications

EPA Certification Number:	Number: N/A
EPA Certified Emissions:	1.0 grams per hour
*LHV Tested Efficiency:	69.5%
**HHV Tested Efficiency:	65.1%
***EPA BTU Output:	7,500 to 36,600 / hr.
****BTU Input:	13,100 to 49,900 / hr.
Vent Size:	3" or 4" Type "L" or "PL"
Hopper Capacity:	120 lbs.
Fuel:	Premium Wood Pellets
* Weighted average LHV (Low Heating Value) efficiency using data collected during EPA emissions tests in accordance with the requirements of CSA B415.1.	
** Weighted average HHV (High Heating Value) efficiency using data collected during EPA emissions tests in accordance with the requirements of CSA B415.1.	
*** A range of BTU outputs calculated using HHV efficiency and the burn rates from the EPA tests.	
**** Based on the maximum feed rate per hour multiplied by approximately 8600 BTU's which is the average BTU's from a pound of pellets.	

The CAB50-C is Certified to comply with 2020 particulate emission standards.



This pellet heater needs periodic inspection and repair for proper operation. It is against federal regulations to operate this pellet heater in a manner inconsistent with operating instructions in this manual.

NOTICE: This installation must conform with local codes. In the absence of local codes you must comply with the **ASTM E1509-04, ULC S627-00 and (UM) 84-HUD.**

D. Glass Specifications

This appliance is equipped with 5mm ceramic glass. Replace glass only with 5mm ceramic glass. Please contact your dealer for replacement glass.

E. Electrical Rating (on high)

115 VAC, 60 Hz, Start 5.1 Amps, Run 3.0 Amps

F. Mobile Home Approved

- This appliance is approved for mobile home installations when not installed in a sleeping room and when an outside combustion air inlet is provided.
- The structural integrity of the mobile home floor, ceiling, and walls must be maintained.
- The appliance must be properly grounded to the frame of the mobile home with #8 copper ground wire, and use only listed double-wall connector pipe.
- Outside Air Kit, part 811-0872 or OAK-3 must be installed in a mobile home installation.
- Appliance must be secured to mobile home structure.

G. Sleeping Room

When installed in a sleeping room it is recommended that 3ft of vertical be installed prior to horizontally exiting the room and a smoke/CO alarm be installed in the bedroom; The size of the room must be at least 50ft³ per 1,000 Btu/hr stove input, if the stove exceeds the room size, outside air must be installed.

H. California - Prop65



WARNING

This product and the fuels used to operate this product (wood), and the products of combustion of such fuels, can expose you to chemicals including carbon black, which is known to the State of California to cause cancer, and carbon monoxide, which is known to the State of California to cause birth defects or other reproductive harm. For more information go to: WWW.P65Warnings.ca.gov



WARNING



Fire Risk

Hearth & Home Technologies disclaims any responsibility for, and the warranty will be voided by, the following actions:

- Installation and use of any damaged appliance.
- Modification of the appliance.
- Installation other than as instructed by Hearth & Home Technologies.
- Installation and/or use of any component part not approved by Hearth & Home Technologies.
- Operating appliance without fully assembling all components.
- Operating appliance without legs attached (if supplied with appliance).
- Do NOT Over fire - If appliance or chimney connector glows, you are over firing.

Any such action that may cause a fire hazard.

Improper installation, adjustment, alteration, service or maintenance can cause injury or property damage.

For assistance or additional information, consult a qualified installer, service agency or your dealer.



NOTE: Hearth & Home Technologies, manufacturer of this appliance, reserves the right to alter its products, their specifications and/or price without notice.

Hearth & Home Technologies WILL NOT warranty appliances that exhibit evidence of over-firing. Evidence of over-firing includes, but is not limited to:

- Warped air tube
- Deteriorated refractory brick retainers
- Deteriorated baffle and other interior components

User Guide

2 Operating Instructions

 WARNING
 Fire Risk. <ul style="list-style-type: none">• Do not operate appliance before reading and understanding operating instructions.• Failure to operate appliance properly may cause a house fire.

Visit www.quadrafire.com/shopping-tools/videos to view product and use & care videos.

A. Fire Safety

To provide reasonable fire safety, the following should be given serious consideration:

- Install at least one smoke detector and CO monitor on each floor of your home.
- Locate detectors away from the heating appliance and close to the sleeping areas.
- Follow the detector's manufacturer's placement and installation instructions and maintain regularly.
- A CO detector should be installed in the room with the appliance.
- Conveniently locate a Class A fire extinguisher to contend with small fires.
- In the event of a hopper fire:
 - Evacuate the house immediately.
 - Notify fire department.

B. Non-Combustible Materials

Material which will not ignite and burn, composed of any combination of the following:

- Steel
- Plaster
- Brick
- Iron
- Concrete
- Tile
- Glass
- Slate

Materials reported as passing **ASTM E 136, Standard Test Method for Behavior of Metals, in a Vertical Tube Furnace of 750° C.**

C. Combustible Materials

Material made of/or surfaced with any of the following materials:

- Wood
- Compressed Paper
- Plant Fibers
- Plastic
- Plywood/OSB
- Sheet Rock (drywall)

Any material that can ignite and burn: flame proofed or not, plastered or non-plastered.

D. Fuel Material and Fuel Storage

Pellet fuel quality can greatly fluctuate. This appliance has been designed to burn a wide variety of fuels, giving you the choice to use the fuel that is most economical in your region.

Hearth & Home Technologies strongly recommends only using Pellet Fuel Institute (PFI) certified fuel.

Fuel Material

- Made from sawdust or wood by-products
- Depending on the source material it may have a high or low ash content.

Higher Ash Content Material

- Hardwoods with a high mineral content
- Fuel that contains bark
- Standard grade pellets, high ash pellets

Lower Ash Content Material

- Softwoods
- Fuels with low mineral content
- Premium grade pellets

 CAUTION
Do not burn fuel that contains an additive; (such as soybean oil). <ul style="list-style-type: none">• May cause hopper fires• Damage to product may result Read the ingredients list on the package. If you are buying corn the only ingredient that should be listed is corn.

Clinkers

Minerals and other non-combustible materials such as sand will turn into a hard, glass-like substance called a clinker when heated in the fire pot.

Trees from different areas will vary in mineral content. That is why some fuels produce more clinkers than others.

Moisture

Always burn dry fuel. Burning fuel with high moisture content takes heat from the fuel and tends to cool the appliance, robbing heat from your home. Damp pellet fuel can clog the feed system.

Size

- Pellets are either 1/4 inch or 5/16 inch (6-8mm) in diameter
- Length should be no more than 1-1/2 inches (38mm)
- Pellet lengths can vary from lot to lot from the same manufacturer
- Due to length variations, the flame height (feed rate) may need adjusting occasionally. Refer to the section on **Feed Rate Adjustment Instructions** found on [page 12](#).

Performance

- Higher ash content requires the ash drawer to be emptied more frequently
- Hardwoods require more air to burn properly
- Set wall control to "Utility Pellet" if the fire pot and ash pan are filling quickly. This will cause the auto-clean system to empty the fire pot more often.
- Premium wood pellets produce the highest heat output.
- Burning pellets longer than 1-1/2 inches (38mm) can cause an inconsistent fuel feed rate and/or missed ignitions.

We recommend that you buy fuel in multi-ton lots whenever possible. However, we do recommend trying various brands before purchasing multi-ton lots to ensure your satisfaction.

Changing to Different Fuel Type

- Empty the hopper of the previous fuel
- Thoroughly vacuum hopper before filling with the new fuel
- Select the appropriate setting on the FUEL SELECTION screen on the thermostat wall control

The burn rate, BTU content and heat output will all vary depending on the fuel selected.



CAUTION

Tested and approved for wood pellets. Burning of any other type of fuel voids your warranty.

Storage

- Wood pellets should be left in their original sealed bag until using to prevent moisture absorption.
- This will also prevent rodents from becoming a problem.
- Do not store any pellet fuel within the clearance requirements or in an area that would hinder routine cleaning and maintenance.

E. General Operating Information

1. Thermostat Calls For Heat

The appliance is like most modern furnaces; when the thermostat calls for heat, your appliance will automatically light and deliver heat. When the room is up to temperature and the thermostat is satisfied, the red call light will shut off and the appliance will shut down. The red call light is located behind the left access panel.

2. Heat Output Controls

This appliance is equipped with a heat output control switch that has three settings or burn rates; low, medium and high (**Figure 10.1**). The appliance will turn on and off as the thermostat demands. When the thermostat calls for heat, the appliance will always start up on High. After burning approximately 4 minutes, the appliance will then burn at the rate at which it was originally set. If the appliance is set at one of the lower settings, it will run quieter but takes longer to heat up an area than if it were set at a higher burn rate. Regardless of the burn rate, when the area is warm enough to satisfy the thermostat, the appliance will shut off.

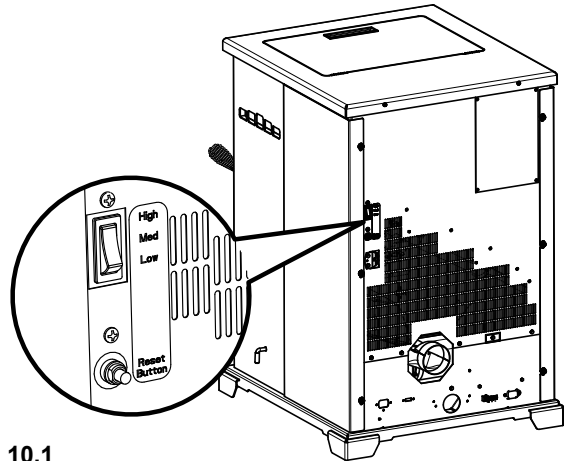

Figure 10.1

F. Before Your First Fire

1. First, make sure your appliance has been properly installed and that all safety requirements have been met. Pay particular attention to the fire protection, venting and thermostat installation instructions.
2. Double check that the ash drawer and firebox are empty!
3. Check that cleaning rod is in the fully closed position.
4. Close and latch the door.



CAUTION

Tip of thermocouple must be in contact with the inside end of the thermocouple cover.

- Missed ignitions can occur.



CAUTION

HOT WHILE IN OPERATION. KEEP CHILDREN, CLOTHING AND FURNITURE AWAY. CONTACT MAY CAUSE SKIN BURNS.

G. Hopper Lid and Hopper Switch

1. Lift up the hopper lid; now you can fill the hopper with fuel.
2. The hopper switch is designed to shut down the feed motor when the hopper lid is open. Leaving the lid open too long can cause the fire to go out (**Figure 11.1**).

NOTE: The hopper switch is activated by a magnet attached to the Hopper Lid.

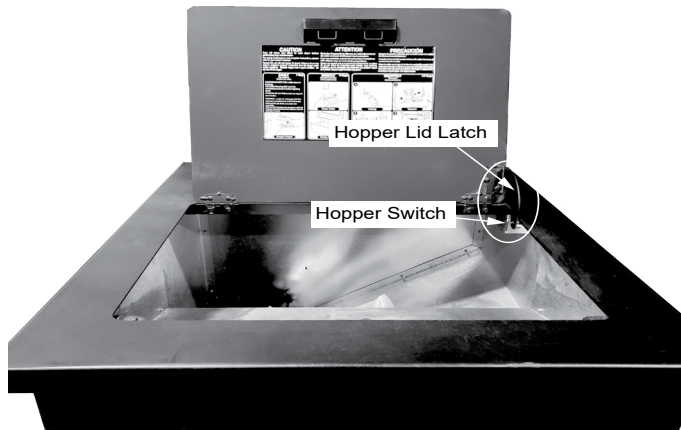

Figure 11.1

H. Starting Your First Fire



CAUTION

Odors and vapors released during initial operation.

- Curing of high temperature paint.
- Open windows for air circulation.

Odors may be irritating to sensitive individuals.

1. A thermostat is required for proper operation of this appliance. If you have to adjust the feed rate after you have started the fire, most of the pellets in the hopper will need to be removed so start out with filling the hopper approximately 1/4 full at this time. Set the thermostat to its lowest setting and plug the power cord into nearby outlet.
2. The exhaust blower will stay on for approximately 18 minutes even though the thermostat is not calling for heat. This is normal.
3. Locate the heat output control switch mounted on the back of the appliance in the upper left corner (**Figure 10.1 on page 10**).
4. Turn it to the "high" setting by pushing the top of the control switch in and then adjust the thermostat to its highest setting.
5. Look through the hole in the left lower side panel and you will see the red call light on the control box will be on (**Figure 11.2**). This indicates the thermostat is calling for heat.

6. The fuel feed system and the igniter should now be on.
7. For your first fire it will be necessary to press the reset button once approximately 2 minutes after start up and again in 5 minutes. Reset as needed or every 60 seconds until pellets begin to drop into fire pot. This will fill the feed system and allow the appliance to begin dropping pellets. Or you can put a handful of pellets in the fire pot to speed up the process. The appliance will continue to run as long as the thermostat is calling for heat.
8. Once the appliance has ignited, let it burn for approximately 15 minutes, then set the thermostat to the desired room temperature. Adjust the heat output control switch to the desired setting.

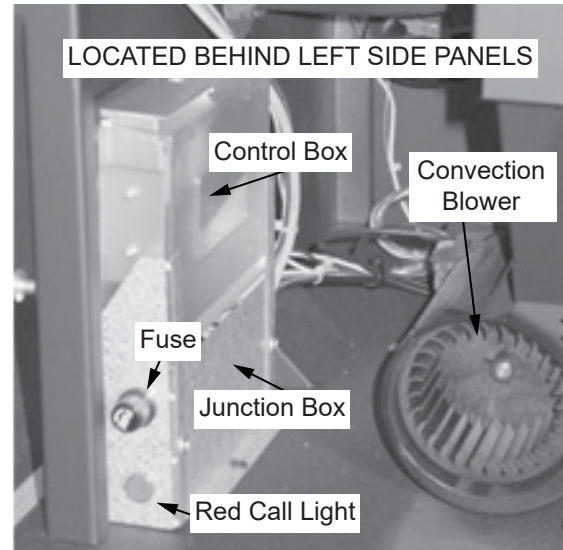

Figure 11.2

I. Fire Characteristics

A properly adjusted fire with the heat output control switch set on "high" has a short active flame pattern that extends out of the firepot approximately 4 to 8 inches (102 to 203mm).

If the fire has tall flames with black tails and seems somewhat lazy, the feed rate will need to be reduced. This is done by sliding the fuel adjustment control rod down, which will reduce the feed (**Figure 12.2**).

If the fire is not 4 to 8 inches (102 to 203mm) tall, slide the fuel adjustment control rod up to increase the feed. A medium and low setting will give a shorter flame. The flame will rise and fall somewhat. This is normal.

J. Feed Rate Adjustment Instructions

1. Loosen the thumb screw.
2. Pull the feed adjustment control rod up to increase the feed rate and flame height or push down to decrease the feed rate and flame height.
3. Re-tighten the thumb screw. A new stove has a break in period. The fire characteristics should be checked again after 5 bags of pellets and adjustments made if necessary.



Figure 12.1

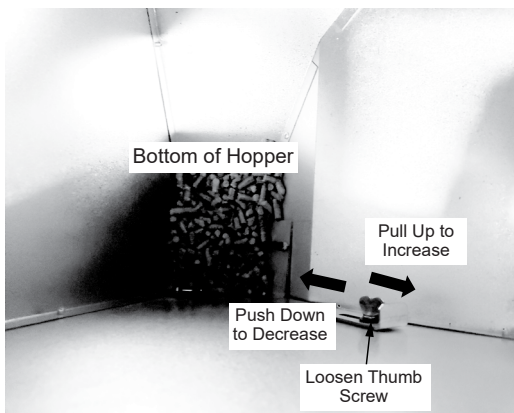

Figure 12.2

K. Ignition Cycles

1. At the beginning of each ignition cycle, it is normal to see some smoke in the firebox. The smoke will stop once the fire starts.
2. The convection blower will automatically turn on after your appliance has been burning for approximately 10 minutes. This blower transfers heat from your appliance into the room, and will continue to run after the thermostat has stopped calling for heat until the appliance has cooled down.
3. Occasionally the appliance may run out of fuel and shut itself down. When this happens, the red call light will be on (**Figure 11.2 on page 11**).
 - To restart it, fill the hopper and press the reset button. When you press the reset button the red call light will go out. Release the button and the light will come back on. Continue pushing the button once a minute until pellets begin to fall into the fire pot.
 - You should see a fire shortly. If not, follow the instructions, for **Starting Your First Fire** on [page 11](#).

L. Clear Space

Mantel:

Avoid placing candles and other heat-sensitive objects on mantel or hearth. Heat may damage these objects.

NOTICE: Clearances may only be reduced by means approved by the regulatory authority having jurisdiction.



WARNING



Fire Risk.

Do NOT place combustible objects in front of the appliance. High temperatures may ignite clothing, furniture or draperies. Maintain a minimum clearance of 3 feet (914mm) in front of appliance.



WARNING



Fire Risk.

Keep combustible materials, gasoline and other flammable vapors and liquids clear of appliance.

- Do NOT store flammable materials in the appliance's vicinity.
- **DO NOT USE GASOLINE, LANTERN FUEL, KEROSENE, CHARCOAL LIGHTER FLUID OR SIMILAR LIQUIDS TO START OR "FRESHEN UP" A FIRE IN THIS Appliance.**
- **DO NOT BURN GARBAGE OR FLAMMABLE FLUIDS SUCH AS GASOLINE, NAPHTHA OR ENGINE OIL.**
- **DO NOT USE CHEMICALS OR FLUIDS TO START THE FIRE.**
- Keep all such liquids well away from the appliance while it is in use.
- Combustible materials may ignite.

M. Thermostat Operation

For accurate temperature control and comfort, correct location is very important. On new installations, the guidelines listed in the installation manual under **Thermostat Installation** should be followed as closely as possible.

To operate thermostat simply slide the Slide Control that is located at top of thermostat, left or right to adjust the temperature of the room (**Figure 13.1**).

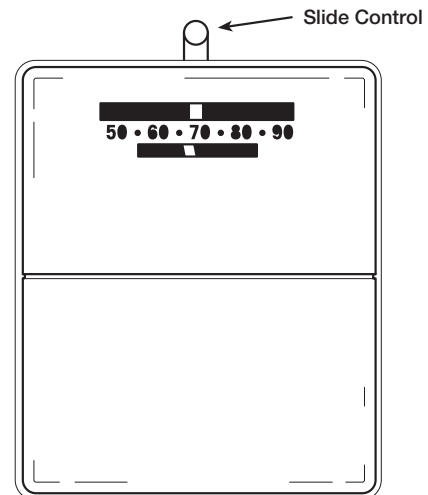

Figure 13.1

NOTE: A thermostat can only control temperature near it. If you find that it is uncomfortable some distance away from the thermostat, change the setting in order to compensate for this.

N. Frequently Asked Questions

What causes my glass to become dirty?

If the glass has white ash build up it is normal and the glass should be cleaned. If it is a black soot build up airflow through the unit may be restricted. The most often cause is overdue maintenance and cleaning. See "Maintaining and Servicing Appliance" in the owner's manual.

How can I get more heat out of the appliance?

The most often cause of diminished heat output is overdue maintenance and cleaning. See "Maintaining and Servicing Appliance" in the owner's manual. If this still does not help, verify the correct settings for maximum heat output. See "Feed Rate Adjustment" under "Operating Instructions" in the owner's manual.

What should I do if I smell smoke or there is ash/soot coming from the appliance?

Seal exhaust venting system to the unit with High Temp silicone. Secure the venting system to the unit with at least (3) screws. All pellet vent pipe must be secured together either by means provided by the pipe manufacturer or by (3) screws at each joint.

Why would my appliance run fine last winter but not start this fall?

It is possible that the stove was not properly prepared for the Non-burn season. See "Trouble shooting" in the owner's manual.

Why would the metal on the inside of the appliance begin to flake?

There are some pellet mills that get their raw materials from lumber mills that purchase logs that are transported in sea water. These pellets can have a higher salt content and cause the metals in the unit to corrode prematurely and deteriorate. If you are seeing any components inside the firebox deteriorate it is recommended to change pellet brands immediately.

Why does only the exhaust blower run when I unplug and plug back in my appliance?

This is a Safety feature to prevent the unit from operating in an unsafe condition. Allow the unit to run and it will return to normal operation.

Is there a place to lubricate the blowers to quiet them down?

The most often cause of noisy blowers is from the impellers becoming dirty over time. See "General Maintenance & Cleaning" under "Maintaining & Servicing Appliance" in the owner's manual. No form of lubrication should ever need applied to the blowers.

Why are different components cycling on and off in my appliance at random?

The selector switch on control box may be on the wrong setting. Refer to the Reference Materials section of our owner's manual for details.

What is the metal object with the bend in it for that came inside the plastic bag?

It is a clean-out tool used to help clean the fire pot and remove any jams in the rare event they occur in the feed tube.

Why is there a black residue building up on the outside of my home?

Wind can cause this to happen. If the appliance is operating correctly very little soot should ever exit the termination cap. Also check to be sure the venting is installed per the owner's manual and local codes.

Do I need an outside air kit?

Outside air is required for mobile home installs and in some jurisdictions. Refer to "Listing & Code Approvals", "Mobile Home Installation" and "Appliance Set-up" owner's manual. Also refer to local building codes.

I am seeing sparks coming out of my pipe (termination cap) outside is this safe?

This is normal. As long as clearances to combustibles were followed this is safe.

My unit sounds like a freight train at times what can be done to eliminate this?

This is referred to as Rumbling. Maintenance may be needed see "Maintaining and Servicing appliance" in the owner's manual. Decrease fuel flow see "Feed rate adjustment" under Operating Instructions".

Why does my unit run fine on high, but shuts down on low and medium?

Maintenance may be needed see "Maintaining and Servicing Appliance" See also "Trouble Shooting".

Can I use another brand of wall thermostat or remote system?

Yes, any remote/wall thermostat system that does not require power from the appliance should work.

I have no power to anything. Does this unit have a circuit breaker or fuse or a reset button?

This unit has one serviceable fuse in the junction box and a reset button for the thermostat circuit.

Can I burn corn in my unit?

Corn is not an approved fuel for the CAB50-C.

I'm thinking about going green (solar power) and need to know what the power consumption is on my Unit.

CAB50 115 VAC, 60 Hz, Start 5.1 Amps, Run 3.0 Amps

Where is the serial # of my unit is located?

The serial # is located on the back of the stove.

CONTACT YOUR DEALER for additional information regarding operation and troubleshooting.
Visit www.quadrafire.com to find a dealer.

3 Maintenance and Service

When properly maintained, your fireplace will give you many years of trouble-free service. Contact your dealer to answer question regarding proper operation, troubleshooting and service for your appliance. Visit www.quadrafire.com/owner-resources to view basic troubleshooting, FAQs, use & care videos. We recommend annual service by a qualified service technician.

A. Proper Shutdown Procedure

Turn off the thermostat.

This pellet heater has a manufacturer-set minimum low burn rate that must not be altered. It is against federal regulations to alter this setting or otherwise operate this pellet heater in a manner inconsistent with operating instructions in this manual.

Follow the detailed instructions found in this section for each step listed as referenced in the chart below.

B. Quick Reference Maintenance Chart

Cleaning or Inspection	Frequency		Daily	Weekly	Every 2 Weeks	Monthly	Yearly
Ash Pan - Burning Wood Pellets	Every 5 bags of fuel	OR		X			
Ash Pan - Burning Alternate Fuels	Every 1 bag of fuel	OR	X				
Ash Removal from Firebox	More frequently depending on the fuel type or ash build-up	OR		X			
Blower, Combustion (Exhaust)	More frequently depending on the fuel type	OR					X
Blower, Convection	More frequently depending on the operating environment	OR					X
Door Latch Inspection	Prior to heating season	OR				X	
Firebox - Prepare for Non-Burn Season	At end of heating season	OR					X
Fire pot - Burning Softwood Pellets	Every 5 bags	OR		X			
Fire pot - Burning Hardwood Pellets	Every 3 bags	OR		X			
Glass	When clear view of fire pot becomes obscured	OR		X			
Heat Exchanger & Drop Tube	Every 1 ton of fuel	OR			X		
Hopper	Every 1 ton of fuel or when changing fuel types	OR				X	
Top Vent Adapter	More frequently depending on ash build-up	OR					X
Venting System	More frequently depending on the fuel type	OR					X

Table 15.1

NOTICE: These are recommendations. Clean more frequently if you encounter heavy build-up of ash at the recommended interval or you see soot coming from the vent. **Not properly cleaning your appliance on a regular basis will void your warranty.**



CAUTION



Shock and Smoke Hazard

- Turn down thermostat, let appliance completely cool and exhaust blower must be off. Now you can unplug appliance before servicing.
- Smoke spillage into room can occur if appliance is not cool before unplugging.
- Risk of shock if appliance not unplugged before servicing appliance.

C. General Maintenance

1. Types of Fuel

Depending on the type of fuel you are burning will dictate how often you have to clean your fire pot.

If the fuel you are burning has a high dirt or ash content, it may be necessary to clean the fire pot more than once a day.

Dirty fuel will cause clinkers to form in the fire pot. A clinker is formed when dirt, ash or a non-burnable substance is heated to 2000°F (1093°C) and becomes glass-like. See section on **High Ash Fuel Content Maintenance** on [page 20](#) in this section for more details on fuels with high ash content.

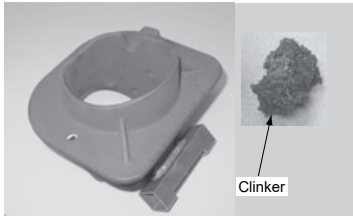

Figure 16.1 - Clinker

2. Cleaning Fire pot with Cleaning Rod & Fire pot Clean-Out Tool:

- **Frequency:** Daily or more often as needed
- **By:** Homeowner
 - a. The appliance must be in complete shutdown and cool and the exhaust blower off. If you are just cleaning the fire pot, there is no need to unplug the appliance.
 - b. Locate the fire pot cleaning rod on the right side of the appliance (**Figure 16.2**). When you pull the cleaning rod straight out it will slide open the firepot floor to allow the ashes to be deposited in the ash drawer. You will see the light color painted area on the cleaning rod to let you know the rod is in OPEN position (**Figure 16.3**).
 - c. Pull the fire pot cleaning rod OUT and IN a couple of times to help shake debris loose. If the rod is hard to pull, it may be necessary to use your fire pot clean-out tool to chip away material that has built up on the bottom plate of the fire pot and to push out any clinkers while in the open position.
 - d. To close the fire pot floor: slightly raise the cleaning rod and then push it back into place. If you have closed the cleaning rod properly (pushed all the way in) you will not see any of the light color painted area (**Figure 16.3**).
 - e. Always have the ash drawer in place before pulling the fire pot cleaning rod, otherwise the ashes will fall down and fill the outside air opening and the appliance will produce soot out of the exhaust and will affect efficiency.

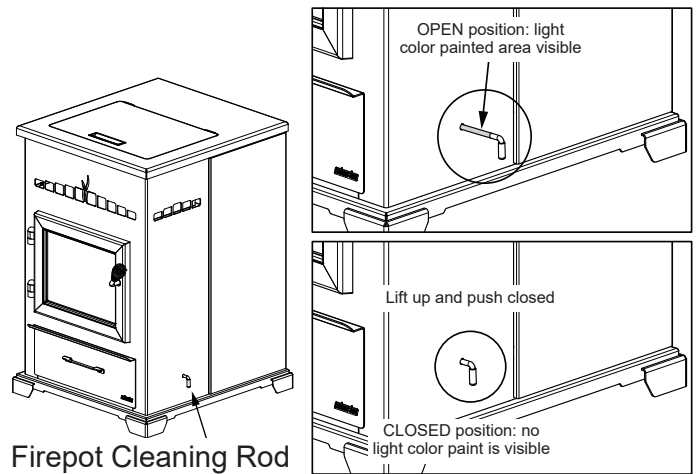

Figure 16.2

Figure 16.3



WARNING



Fire Risk

- NEVER pull firepot cleaning rod out when appliance is operating.
- Cleaning Rod MUST be completely pushed in before operating appliance.
- Hot pellets may fall into ash pan and start a fire or mis-starts due to lack of vacuum.

3. Ash Removal from Firebox

- **Frequency:** Weekly or more frequently depending on ash build-up.
- **By:** Homeowner
 - a. There must not be any hot ashes in the firebox during cleaning so allow the appliance to completely cool. The firebox ash should be removed every time the exhaust path is cleaned. Frequent cleaning of the ash in the firebox will help slow down the build-up of ash in the exhaust blower and vent system.
 - b. Vacuum out the firebox thoroughly on both sides of the firebox and the floor and ceiling. The ash drawer should be emptied every time you clean the firebox. Remember to place the ash and debris into a metal or non-combustible container (See section on **Disposal of Ashes** on [page 17](#)).
 - c. Always have the ash drawer in place before pulling the fire pot cleaning rod, otherwise the ashes will fall down and fill the outside air opening and the appliance will produce soot out of the exhaust and will affect efficiency.



WARNING



Burn Risk

- NEVER remove ash drawer while appliance is operating.

4. **Cleaning Ash Drawer**

- **Frequency:** Weekly or every 5 bags of fuel
- **By:** Homeowner
 - a. There must not be any hot ashes in the ash drawer when you empty it, so allow the appliance to completely cool.
 - b. Locate the ash drawer underneath the fire pot. Slide the ash drawer straight out. Empty into a non-combustible container and re-install the ash drawer. See section on **Disposal of Ashes** on [page 17](#).
 - c. Always have the ash drawer in place before pulling the fire pot cleaning rod, otherwise the ashes will fall down and fill the outside air opening and the appliance will produce soot out of the exhaust and will affect efficiency.

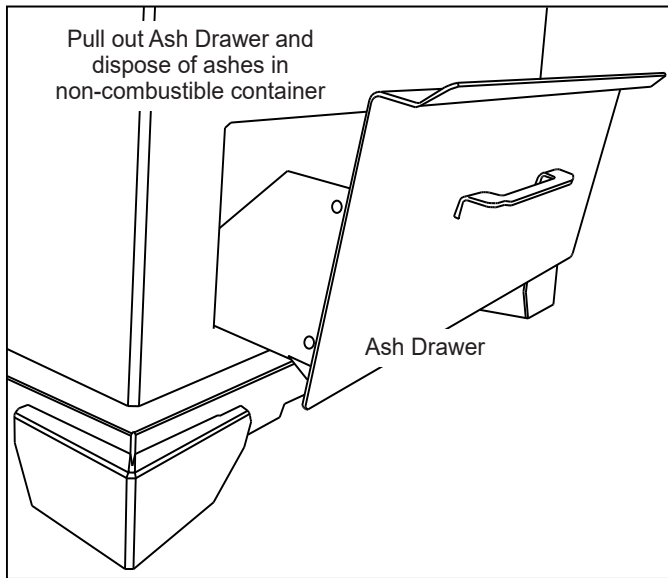



Figure 17.1

5. **Disposal of Ashes**

- **Frequency:** As needed
- **By:** Homeowner

Ashes should be placed in a metal container with a tight-fitting lid. The closed container of ashes should be placed on a non-combustible floor or on the ground, well away from all combustible materials, pending final disposal.

If the ashes are disposed of by burial in soil or otherwise locally dispersed, they should be retained in the closed container until all cinders have been thoroughly cooled.

	WARNING
	Disposal of Ashes <ul style="list-style-type: none">• Ashes should be placed in metal container with tight fitting lid.• Ashes should be retained in closed container until all cinders have thoroughly cooled.

6. **Cleaning the Exhaust Path, Baffles & Drop Tube**

- **Frequency:** Monthly or every 25 bags or more frequently depending on ash build-up.
 - **By:** Homeowner
 - a. Appliance must be completely cool.
 - b. Open the door and remove the center baffle first and then the right and left baffles. See section on **Baffle Replacement** instructions on [page 26](#). Thoroughly vacuum the exhaust path and drop tube and continue throughout the rest of the firebox. Also vacuum the front and back of the baffles.
 - c. Also vacuum the combustion blower impellers or use a soft brush to remove any ash build-up.
- Replace the right and left baffles and then the center baffle and close and latch the door.

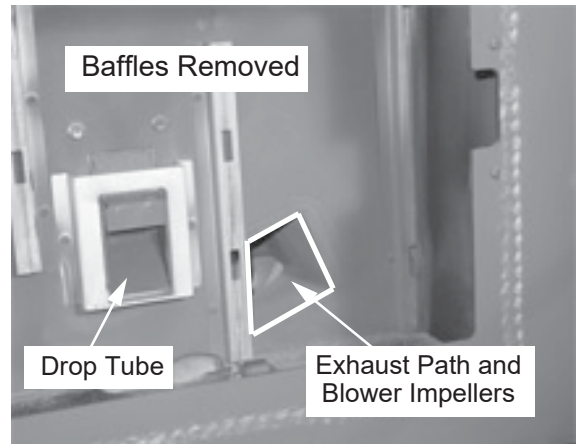

Figure 17.2

7. **Cleaning the Hopper**

- **Frequency:** Monthly or after burning 50 bags of fuel
- **By:** Homeowner

After burning approximately 50 bags of fuel you will need to clean the hopper to prevent sawdust build-up.

A combination of sawdust and pellets on the bottom end of the auger reduces the amount of fuel supply to the fire pot. This can result in nuisance shutdowns and mis-starts.

- a. The appliance must be in complete shutdown. Allow the appliance to completely run out of pellets and cool down.
- b. Empty the hopper of any remaining pellets.
- c. Vacuum the hopper and feed tube.

NOTE: Hearth & Home Technologies recommends to use a heavy duty vacuum cleaners specifically designed for solid fuel appliance cleaning.

8. Soot and Fly Ash: Formation & Need for Removal in Exhaust Venting System.

- **Frequency:** Yearly or more frequently depending on ash build-up.
 - **By:** Qualified Service Technician/Homeowner
- Be sure the appliance is allowed to cool, has been unplugged and the exhaust blower is off.

The products of combustion will contain small particles of fly ash. The fly ash will collect in the exhaust venting system and restrict the flow of the flue gases.

At start-up if there is incomplete combustion, or if there is a shutdown or incorrect operation of the appliance it will lead to some soot formation. This will collect in the exhaust venting system.

The venting (chimney) system may need to be cleaned at least once a year or more often depending upon the quality of your fuel or if there are any horizontal pipe sections. Ash will build up more quickly in the horizontal sections and elbows.

9. Door Handle Inspection

- **Frequency:** Monthly or prior to heating season
- **By:** Homeowner

The gasket between the glass and firebox should be inspected periodically to make sure there is a good seal. Check door handle for smooth cam operation.

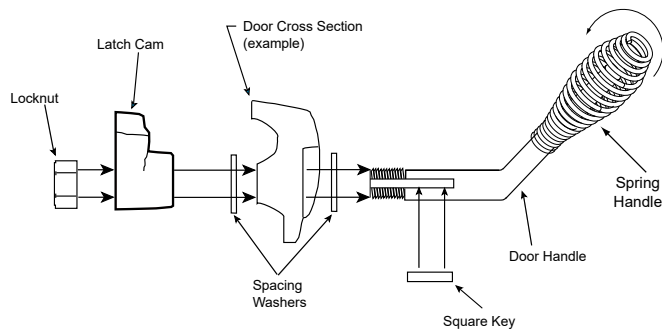

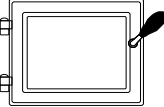



Figure 18.1

10. Cleaning the Glass

- **Frequency:** When clear view of the fire pot becomes obscure
- **By:** Homeowner
 - a. Appliance must be completely cool before cleaning glass.
 - b. Vacuum fly ash from glass and door rope.
 - c. Use a damp paper towel or any non-abrasive glass cleaner. Wipe off with dry towel.

 CAUTION	
	Handle glass assembly with care. When cleaning glass:
	<ul style="list-style-type: none">• Avoid striking, scratching or slamming glass.• Do NOT clean glass when hot.• Do NOT use abrasive cleaners.• Refer to maintenance instructions.

 WARNING	
	Handle glass with care.
	<ul style="list-style-type: none">• Inspect the gasket to ensure it is undamaged.• Do NOT strike, slam or scratch glass.• Do NOT operate appliance with glass assembly removed.

11. Cleaning Exhaust Blower - Requires No Lubrication

- **Frequency:** Yearly or more frequently depending on ash build-up
- **By:** Homeowner or Qualified Service Technician
 - a. Be sure the appliance is allowed to cool, has been unplugged and the exhaust blower is off.
 - b. Follow the directions for cleaning the exhaust path found on [page 17](#).
 - c. If unable to thoroughly clean the blower through this access, follow section on **Side Curtain Replacement** on [page 24](#) to remove right side from the appliance obtain direct access to the exhaust blower.
 - d. Vacuum the blower's impellers. Use care not to bend or damage the blower fins.

NOTE: Hearth & Home Technologies recommends to use a heavy duty vacuum cleaners specifically designed for solid fuel appliance cleaning.

12. Cleaning Convection Blower - Requires No Lubrication

- **Frequency:** Yearly or more frequently depending on Dust/Dirt build-up
- **By:** Homeowner or Qualified Service Technician
 - a. Be sure the appliance is allowed to cool and has been unplugged.
 - b. Follow section on **Side Curtain Replacement** on [page 24](#) to remove left side from the appliance to obtain direct access to the convection blower.
 - c. Sweep or vacuum out any build-up. Use a brush or compressed air to loosen dirt if needed.

13. Cleaning the Top Vent Adapter

- **Frequency:** Yearly or more frequently depending on ash build-up
- **By:** Homeowner
 - a. The appliance must be in complete shutdown and the exhaust blower should be off. Allow the appliance to completely cool down.
 - b. Open the clean-out cover (**Figure 19.1**).
 - c. Sweep or vacuum out any ash build-up.

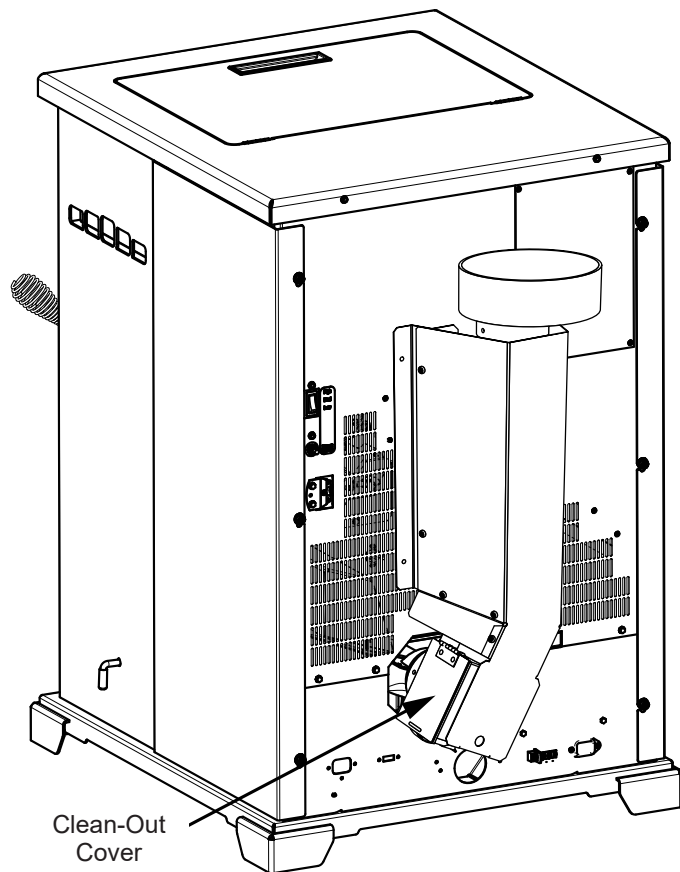

Figure 19.1

14. Preparing Firebox for Non-Burn Season

- **Frequency:** Yearly
- **By:** Homeowner
 - a. Be sure the appliance is allowed to cool, has been unplugged and the exhaust blower is off.
 - b. Remove all ash from the firebox and vacuum thoroughly.
 - c. Paint all exposed steel, including cast-iron.
 - Purchase paint from your local dealer.
 - Must use a high-temperature paint made specifically for heating appliances.

D. High Ash Fuel Content Maintenance

- **Frequency:** As needed
- **By:** Homeowner



Poor quality pellet fuel, or lack of maintenance, can create conditions that make the fire pot fill quickly with ashes and clinkers.

This condition makes the appliance susceptible to overfilling the fire pot with pellets which may result in smoking, sooting and possible hopper fires. **Figure 20.1** shows an example where the fire pot overfills, pellets back up into the feed tube and ash has accumulated in the firebox.

An inefficient and non-economical method of burning of fuel caused by poor quality pellet fuel is shown in **Figure 20.2**.

The correct flame size when good quality, premium pellet fuel is burned is shown in **Figure 20.3**.

If the ash buildup exceeds the half way point in the fire pot IMMEDIATE ATTENTION AND CLEANING IS REQUIRED.

	WARNING
	Fire Risk <ul style="list-style-type: none">• High ash fuels, or lack of maintenance, can cause the fire pot to overfill. Follow proper shutdown procedure if ash buildup exceeds halfway point in fire pot.• Failure to do could result in smoking, sooting and possible hopper fires.

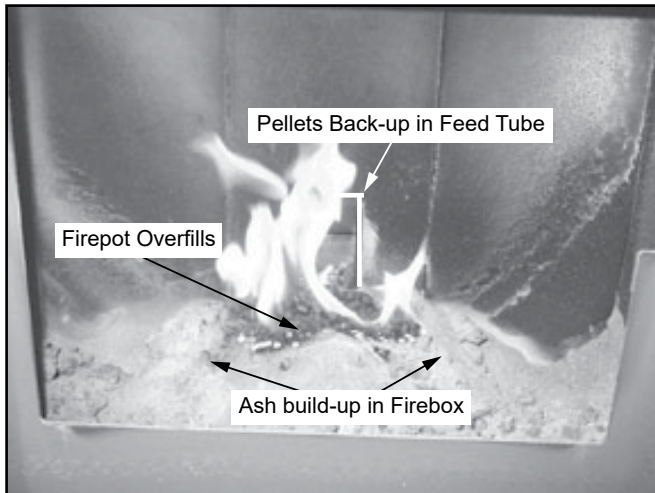

Figure 20.1

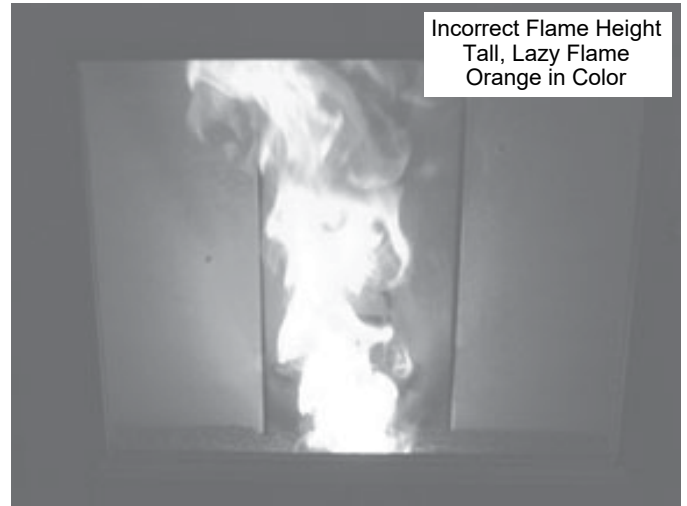

Figure 20.2

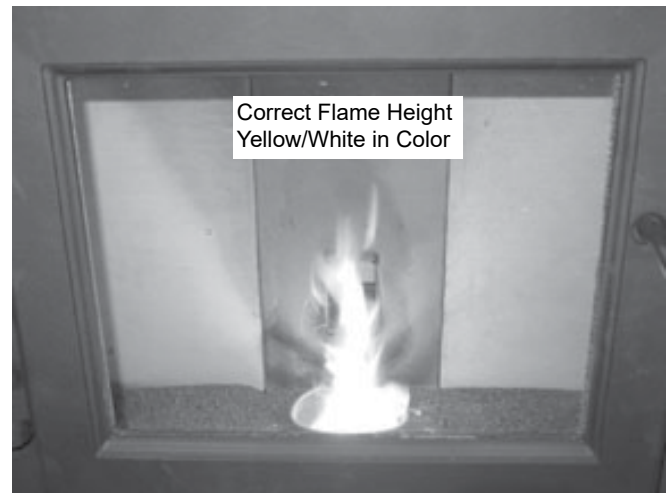

Figure 20.3

E. Soot or Creosote Fire

Establish a routine for the fuel, wood burner and firing technique. Check daily for creosote build-up until experience shows how often you need to clean to be safe. Be aware that the hotter the fire the less creosote is deposited, and weekly cleaning may be necessary in the mild weather even though monthly cleaning may be enough in the coldest months. Contact your local municipal or provincial fire authority for information on how to handle a chimney fire.

In the event of a soot or creosote fire, close the firebox door, exit the building immediately and contact the proper fire authorities.

DO NOT under any circumstances re-enter the building.

4 Troubleshooting Guide

With proper installation, operation, and maintenance your appliance will provide years of trouble-free service. If you do experience a problem, this troubleshooting guide will assist a qualified service person in the diagnosis of a problem and the corrective action to be taken. This troubleshooting guide can only be used by a qualified service technician.

Symptom	Possible Cause	Corrective Action
Plug in appliance - No response.	No current to outlet. 7 amp fuse defective. #3 snap disc tripped or defective. Control box defective.	Check circuit breaker at service panel. Replace fuse. Reset or replace snap disc. Replace control box.
Call light on. No fire. No fuel in fire pot.	Out of fuel. #2 snap disc may be defective. Vacuum switch not closing, no vacuum. Control box defective.	Check hopper. Fill with fuel. Replace snap disc. Check exhaust blower is plugged in and operating. Check vacuum switch is plugged in. Check vacuum hose is in good condition, clear and connected at both ends. Check thermocouple is in good condition and plugged in properly. Make sure venting system is clean. Make sure front door is closed. Replace control box.
Call light on. No fire. Partially burned fuel in fire pot.	Fire pot clean-out plate not closed. Fire pot is dirty (missed ignition).	Check that fire pot clean-out plate is fully closed. Clean fire pot. Make sure there is no clinker in the fire pot. Clinkers may have to be broken up with fire pot scraper tool or other means.
Call light on. No fire. Unburned pellets in fire pot.	Fire pot clean-out plate not closed. Fire pot is dirty. Ignition hole blocked. Igniter not working. Control box defective.	Check that fire pot clean-out plate is fully closed. Clean fire pot. Make sure there is not a clinker in the fire pot. Clinkers may have to be pushed out of fire pot with fire pot scraper tool or other means. Scrape with solid piece of wire. Remove ash pan to see if igniter is glowing red on start-up. Check igniter wires for good connection. Replace igniter using 1/4 inch male /female spade connectors. Replace control box.
Slow or smoky start-up.	Fire pot clean-out plate not closed. Fire pot is dirty. Excessive amount of fuel at start-up.	Check that fire pot clean-out is fully closed. Clean fire pot. Make sure there is not a clinker in the fire pot. Clinkers may have to be pushed out of fire pot with fire pot scraper tool or other means. Reduce feed rate using feed rate adjustment control rod located inside hopper.

Table 21.1

Symptom	Possible Cause	Corrective Action
Slow or smoky start-up (Cont'd)	Dirty exhaust and/or venting system.	Check for ash build up in appliance, including behind rear panels, firebox, heat exchanger, exhaust blower and venting.
Feed system fails to start.	Out of fuel. #2 snap disc may be defective. Vacuum switch not closing. No vacuum. Feed system jammed or blocked. Feed spring not turning with feed motor. Feed motor defective or not plugged in.	Check hopper, fill with fuel. Replace snap disc. Firebox door must be closed securely. Check exhaust blower is plugged in and operating. Check vacuum switch is plugged in. Check vacuum hose is in good condition, clear and connected at both ends. Check thermocouple is in good condition and plugged in properly. Make sure venting system is clean. NOTE: High winds blowing into the venting system can pressurize the firebox causing loss of vacuum. Empty hopper of fuel. Use a wet/dry vacuum cleaner to remove remaining fuel, from hopper, including feed tube. Check feed chute for obstructions. Loosen 2 screws and jiggle feed assembly. Check that set screw is tight on feed spring shaft at end of feed motor. Check connections on feed motor, replace if defective.
No call light. Appliance does not begin start sequence.	Thermostat not set to a high enough temperature. Snap Disc #3 tripped. No power. Fuse blown. Connections at thermostat and/or appliance not making proper contact. Defective thermostat or thermostat wiring. Control box defective.	Adjust thermostat above room temperature. Reset snap disc. Connect to power. Replace fuse. Check connections at thermostat and appliance. Replace thermostat or wiring. NOTE: To test thermostat and wiring, use a jumper wire at the thermostat block on the appliance to by-pass thermostat and wiring. Replace control box.
Appliance fails to shut off.	Call light on.	Turn thermostat off. If call light does not go out, disconnect thermostat wires from appliance. If call light does go out, thermostat or wires are defective.

Table 22.1

Symptom	Possible Cause	Corrective Action
Convection blower fails to start.	No call light. #1 snap disc defective. Blower not plugged in. Blower is defective. Control box is defective.	Defective control box. Replace snap disc. Check that blower is plugged into wire harness. Replace blower. Replace control box.
Exhaust blower fails to start or does not shut off.	Blower not plugged in. Blower is clogged with ash. Blower is defective. Control box is defective.	Check that blower is plugged into wire harness. Clean exhaust system. Replace blower. Replace control box.
Large, lazy flame, orange color. Black ash on glass.	Dirty appliance. Poor fuel quality, high ash content. Fire pot clean-out plate not completely closed. Excessive amount of fuel.	Clean appliance, including fire pot, heat exchangers and venting system. Remove stainless steel baffle from firebox to clean ash from on top of baffle. Clean behind rear brick panels. Change fuel brand to premium. Check that fire pot clean-out plate is fully closed. Reduce feed rate using feed rate adjustment control rod located inside hopper.
Nuisance shutdowns.	Low flame. Sawdust buildup in hopper. Feed motor is reversing. Defective thermocouple. Defective control box. Fire pot more than 1/2 full	Increase feed by opening feed rate adjustment control rod located inside hopper. Clean hopper, see page 17 . Check for good connections between feed motor and wire harness. Replace thermocouple. Replace control box. See page 20 for detailed instructions for “High Ash Fuel Content Maintenance”.
Appliance calls for heat. Call light illuminates. Exhaust blower starts. No feed or igniter.	Thermocouple is defective or not properly plugged in. Defective control box	Check connections on thermocouple or replace if defective. A flashing yellow light on the control box indicates a problem with the thermocouple. Replace control box.

Table 23.1

5 Service Parts Replacement

A. Side Curtain Replacement

1. Using a #2 Phillip Head screwdriver, a 3/8 inch wrench or a 3/8 Inch socket, loosen the three (3) bolts from the back side of the appliance (**Figure 24.1**).
2. Remove side curtain by lifting up and out of the slots (**Figure 24.2**).

NOTE: If conducting other service part replacements, do it at this time:

- Right side: Feed motor, vacuum switch, and combustion blower (**Figure 30.3 on page 30**).
- Left side: Control box, convection blower, fuse, junction box, and red call light (**Figure 30.2 on page 30**).

3. Add new side curtain in reverse order.

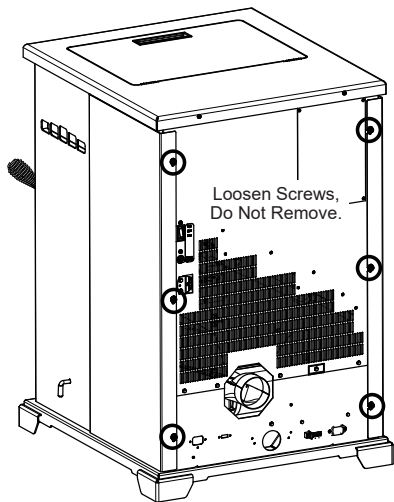

Figure 24.1



Figure 24.2

B. Convection Blower Replacement

1. Turn down the thermostat, let appliance completely cool and then unplug appliance before servicing.
2. The convection blower is located on the floor at the rear of the appliance.
3. Follow section on **Side Curtain Replacement** on [page 24](#) to remove left side from the appliance.
4. Release blower wires from the nylon wire retainer if applicable. This appliance has 1 black and 1 white wire coming from the blower.
5. Remove the wing bolt and move the blower and hold-down bracket toward the back of the appliance to release the locating tab (**Figure 24.3**). Pull the blower out from under the convection plenum. Slide the blower out of the appliance. Disconnect the wires from the spade connectors at this time (**Figure 24.4**).
6. Return wires to nylon wire retainer. Make sure wires do not contact any moving parts or touch any surfaces that may become hot (**Figure 24.4**).

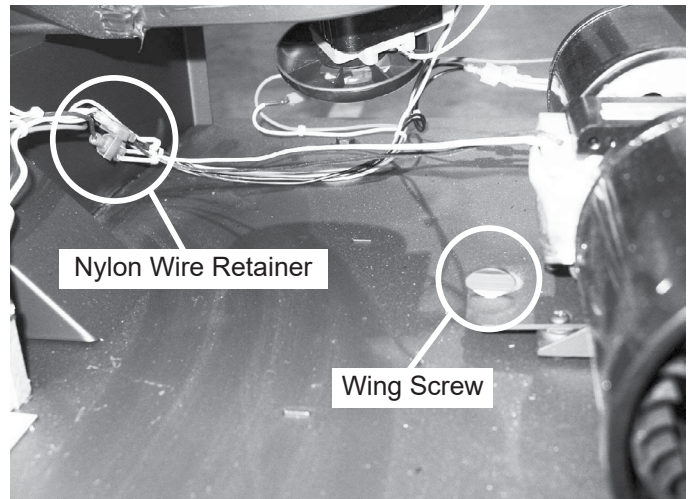

Figure 24.3

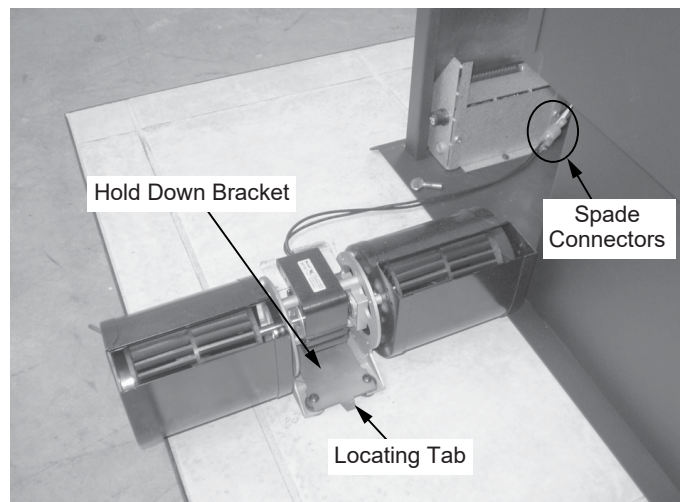

Figure 24.4

C. Exhaust Blower Replacement

1. Turn down the thermostat, let appliance completely cool and then unplug appliance before servicing.
2. Follow section of **Side Curtain Replacement** on [page 24](#) to remove right side from the appliance.
3. Disconnect two (2) white wires from the white and blue wires of the exhaust blower.
4. There is a removable plate on the exhaust blower. Depending on the model, use a 1/4 inch socket, or 1/4 inch Nut Driver or #2 Phillips Head screw driver to loosen the six (6) screws in the keyhole shaped holes and rotate the plate. It is only necessary to loosen screws (**Figure 25.1**).
5. Remove the exhaust blower and gasket.
6. Check for degradation on the gasket and replace if necessary using the gasket included in the kit.
7. Re-install in reverse order.

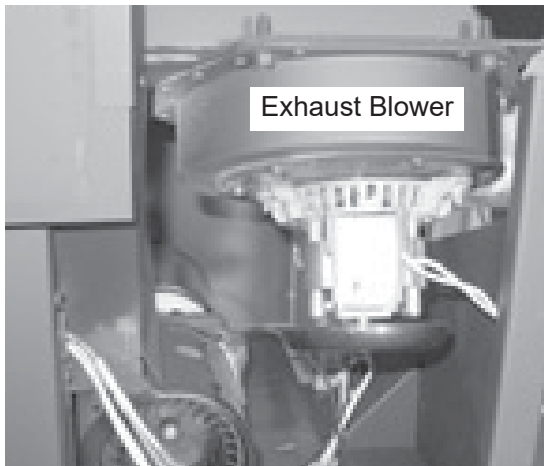

Figure 25.1

D. Snap Disc #1, #2, #3 Replacement

Snap Disc #1 - Convection Blower

1. Turn down thermostat, let appliance cool completely if running. Then unplug appliance before servicing.
2. Follow section on **Side Curtain Replacement** on [page 24](#) to remove right side from the appliance.
3. Snap disc #1 is located on the convection plenum below the feed motor (**Figure 25.2**).
4. It has two purple wires attached to it with 1/4 inch female spade terminals.
5. Disconnect the two wires from the snap disc. Using a #2 Phillips screwdriver, remove the two screws securing the snap disc to the appliance.
6. Re-install in reverse.

Snap Disc #2 - Fuel Delivery Interrupt

1. Turn down thermostat, let appliance cool completely if running. Then unplug appliance before servicing.
2. Follow section on **Side Curtain Replacement** on [page 24](#) to remove right side from the appliance.
3. Snap disc #2 is located on the convection plenum in the center of the appliance above the convection blower (**Figure 25.2**).
4. It has a black wire and an orange wire attached to it with 1/4 inch female spade terminals.
5. Disconnect the two wires from the snap disc. Using a #2 Phillips screwdriver, remove the two screws securing the snap disc to the appliance.
6. Re-install in reverse.

Snap Disc #3 - Feed Motor - Manual Reset

1. Turn down thermostat, let appliance cool completely if running. Then unplug appliance before servicing.
2. Follow section on **Side Curtain Replacement** on [page 24](#) to remove right side from the appliance.
3. Snap disc #3 is located on the bracket on the feed tube near the feed motor (**Figure 25.2**).
4. It has two gray wires attached to it with 1/4 inch female spade terminals.
5. The locating bracket is attached to the feed tube with an 8 X 32 inch wing nut. Remove the wing nut to detach the bracket from the feed tube.
6. Disconnect the two wires from the snap disc.
7. Using a #2 Phillips screwdriver, remove the screw securing the snap disc to the bracket (**Figure 25.3**).
8. Re-install in reverse.

Figure 25.2

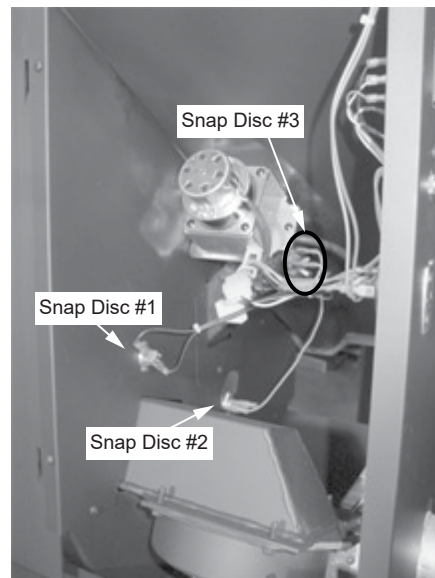
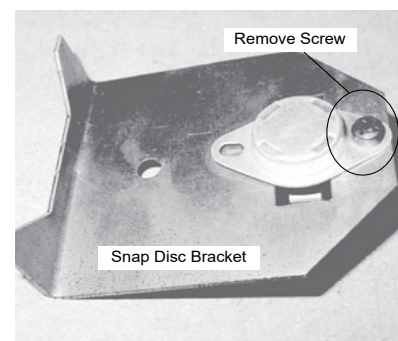

Figure 25.3



E. Igniter Replacement

1. Shut down the appliance by turning down the thermostat and let the appliance completely cool down. After the appliance has cooled down, unplug it and remove the ash drawer.
2. The wire leads to the igniter are connected to the wire harness with 1/4 inch male / female spade connectors.
3. Follow section on **Side Curtain Replacement** on [page 24](#) to remove right side from the appliance to expose the spade connectors.
4. Disconnect the spade connectors and remove the igniter from the chamber. Loosen thumb screw and slide igniter out.
5. Install new igniter into the chamber and tighten thumb screw. The wires MUST route through the wire retainer hook and then re-connect the wires to the two (2) leads with the spade connectors (**Figure 26.1**).
6. Double check that the igniter wires are clear of any movement, i.e. ash drawer, fire pot cleaning rod, etc.
7. Re-install the ash drawer and side panel and re-connect the power.

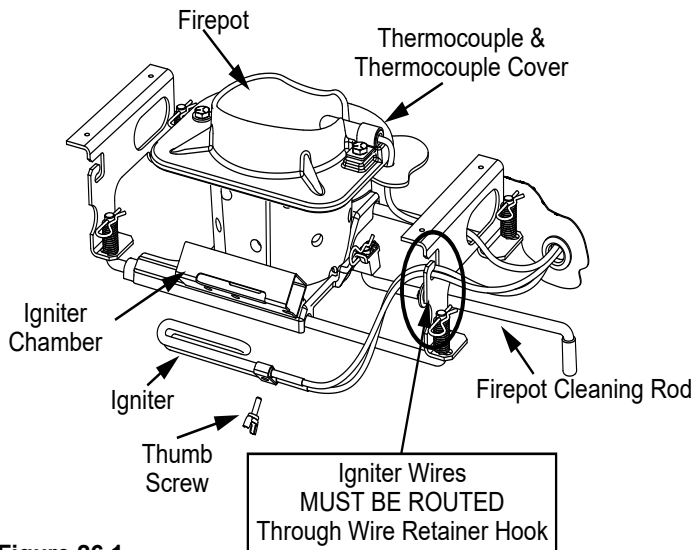

Figure 26.1

F. Baffle Replacement

1. Shut down the appliance by turning down the thermostat and let the appliance completely cool down.
2. Remove the center baffle first by using the handle at the top of the baffle and pull up and then towards you. The hooks on the baffle will slide out of the slots in the bracket (**Figure 26.2**).
3. Remove the left baffle and then the right baffle by pulling up and then towards you. The left and right baffles have similar hooks and slots (**Figures 26.3 and Figure 26.4**).
4. Re-install the baffles in reverse order. Be careful to insert the hooks in their respective slots. Be sure the baffles are completely secure/seated (close, if not touching, the firebox floor).

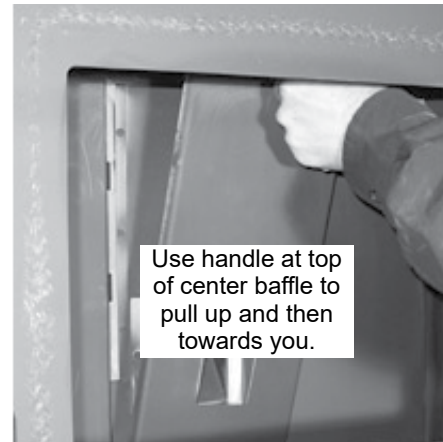

Figure 26.2

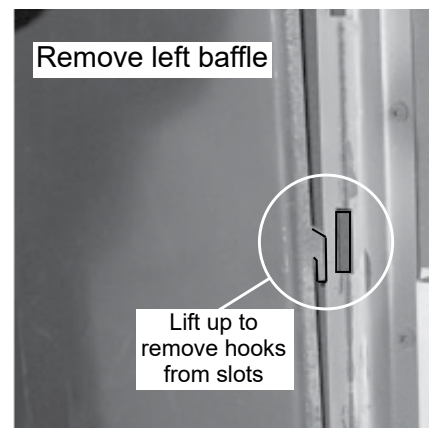

Figure 26.3

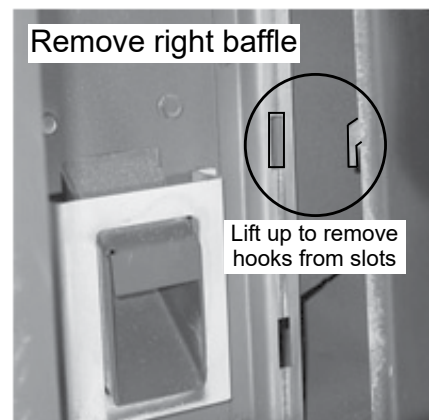

Figure 26.4

G. Glass Replacement

1. Open the door from the appliance by lifting door off of hinge pins and lay on a flat surface face down.
2. Using a Phillips Head screw driver, remove the 4 brackets and set aside (**Figure 27.1**).
3. Remove old glass and replace with the new glass.
4. Re-install the brackets using the same screws.

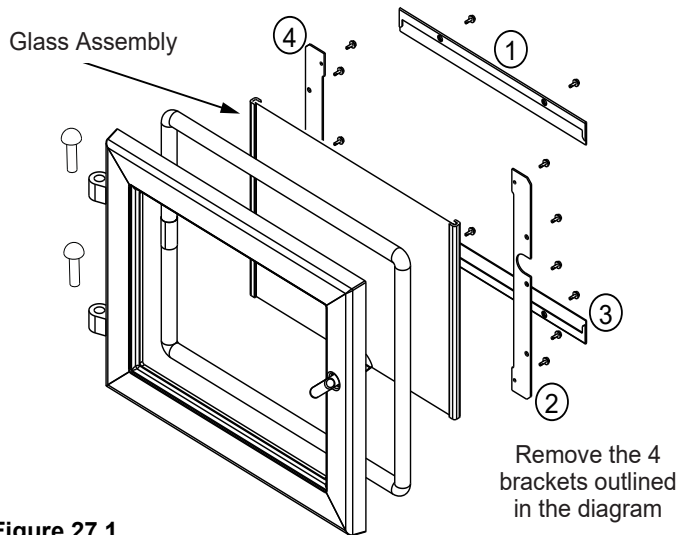

Figure 27.1



WARNING



- Glass is 5mm thick high temperature heat-resistant ceramic glass.
- DO NOT REPLACE with any other material.
- Alternate material may shatter and cause injury.

6 Reference Materials

A. Component Functions

1. Control Box

- The control box is located on the lower left side of the appliance, behind the lower left side panel and above the junction box.
- There is a light located inside of the control box. The internal light will turn green when the appliance has reached a temperature of 200°F (93°C) in the fire pot and will turn red when it reaches 600°F (315°C).
- There is also an internal blue light located in the control box. When you plug in the appliance the blue light will automatically start blinking. This model it should blink 2 times.

To set your control board on the correct number:

- Unplug the appliance.
- Using #2 Phillips screw driver, 3/8" wrench, or 3/8" socket loosen the three screws that hold the right upper and lower side panels in place. You do not need to remove the screws. Remove side panels by lifting up and out.
- Use a #2 Phillips screw driver to remove the control box retainer bracket and lift control box out of the junction box.
- Using a 1/4 inch flat head screw driver turn the rotary switch until the desired number is showing on the dial.
- Re install control box and plug in appliance.
- To confirm your selection is correct count the number of times the blue light flashes.

Example: If you are on setting 2 the control box will flash 2 times every 10 seconds for 1 minute.

Your CAB50-C is set to #2 (2 flashes) (**Figure 28.1**).

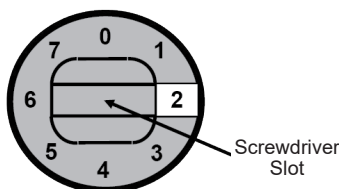

Figure 28.1 - Rotary Switch

NOTE: Do NOT open the control box. This will void the warranty. If you need to plug in or remove the control box you must first unplug the appliance.

When describing the location of a component, it is always AS YOU FACE THE FRONT OF THE APPLIANCE.

2. Convection Blower

The convection blower is mounted at the bottom rear of the appliance. There are 2 impellers, one on each side of the motor. The convection blower pushes heated air through the heat exchange system into the room.

3. Exhaust Blower

The exhaust blower is mounted on the right side of the appliance. The exhaust blower is designed to pull the exhaust from the appliance and push it out through the venting system.

4. Feed System

The feed system is located on the right side of the appliance and can be removed as an entire assembly. The assembly includes the feed motor, mounting bracket, bearing and feed spring (auger). The hollow feed spring (auger) pulls pellets up the feed tube from the hopper area and drops them down the feed chute into the fire pot.

5. Fire pot

The fire pot is made of high quality ductile iron and has a cleaning pull-out rod. The floor of the fire pot opens for cleaning when you pull out the rod. Be sure that the floor returns to a completely closed position or your appliance will not operate properly.

6. Fuse

The fuse is located on the side of the junction box above to the red call light. The fuse will blow should a short occur and shut off power to the appliance.

7. Heat Output Switch

The heat output switch is located on the upper right back panel. The function of the heat output switch is to regulate the burn rates; low, medium and high settings.

8. Hopper Switch

The hopper switch is located in the upper right hand corner of the hopper. This switch is designed to shut down the feed motor whenever the hopper lid is opened.

9. Igniter

The igniter is mounted on the base of the fire pot. Combustion air travels over the red hot igniter creating super heated air that ignites the pellets.

10. Junction Box And Wiring Harness

The junction box is located on the lower left side of the appliance, behind the left side panel. The junction box and wiring harness are replaced as one component.

11. Power Supply

The power outlet is located behind the control box on the back of the appliance, lower left corner. Check the wall receptacle for 120 volt, 60 Hz (standard current). Make sure the outlet is grounded and has the correct polarity. A good surge protector is recommended.

12. Red Call Light

The red call light is on the side of the junction box, below the fuse. The function of the red call light is to indicate that the thermostat is calling for heat.

13. Reset Button

The reset button is located on the back of the appliance in the upper right corner below the heat output control switch. The function of the button is to momentarily open the thermostat circuit, which restarts the system.

14. Thermocouple

The thermocouple is located on top of the firepot inside the thermocouple cover (ceramic protection tube). The thermocouple sends a millivolt signal to the control box indicating the preset temperatures of the green and red lights have been obtained.

15. Thermostat

The appliance is designed to run on a 12 volt AC thermostat. The heat anticipator should be set on the lowest setting available.

16. Snap Disc #1 (Convection Blower) 110°F

Snap disc #1 is located on the right side of the appliance behind the right side panel. There are 2 purple wires connected to it. This snap disc turns the convection blower on and off as needed. Power is always present at snap disc #1.

17. Snap Disc #2 (Fuel Delivery Interrupt) 175°F

Snap disc #2 is located on the center of the convection plenum above the convection blower. There is an orange and a black wire connected to it. This snap disc will turn off the feed system which will turn off the appliance if an over fire condition should occur or if the convection blower should fail to operate. If this occurs you will have to manually reset the snap disc.

18. Snap Disc #3 (Back Burn Protector) 250°F

Snap disc #3 is mounted on the back of the auger tube in the center of the appliance and has a reset button. There are two gray wires connected to it. To access it remove the right side panel. If the fire tries to burn back into the feed system or push exhaust up the feed tube, this snap disc will shut the entire system off. This disc must be manually reset.

19. Vacuum Switch

The vacuum switch is located on the lower right side of the appliance behind right side panel. There are two red wires attached to it. This switch turns the feed system on when vacuum is present in the firebox. The vacuum switch is a safety device to shut off the feed motor if the exhaust or the heat exchanger system is dirty or plugged or if the firebox door is open.

20. Wiring Harness

See Figure 29.1 below.

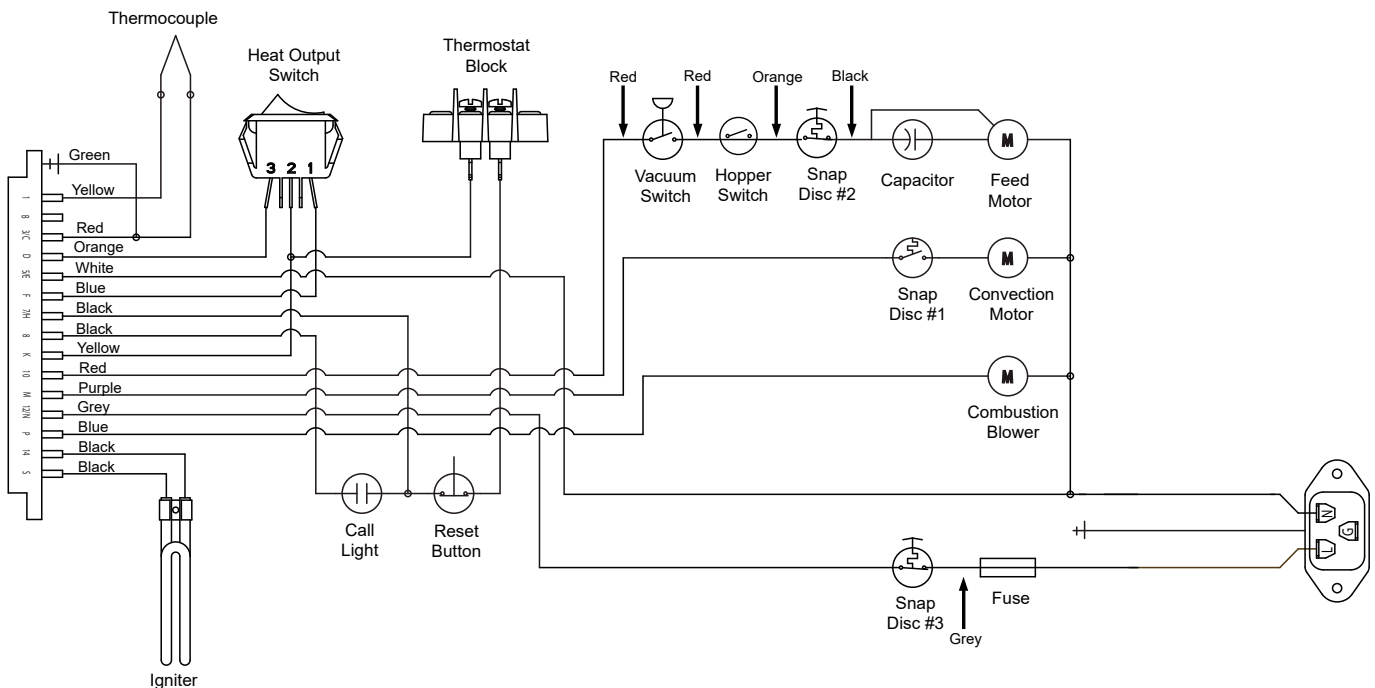

Figure 29.1

B. Component Locations

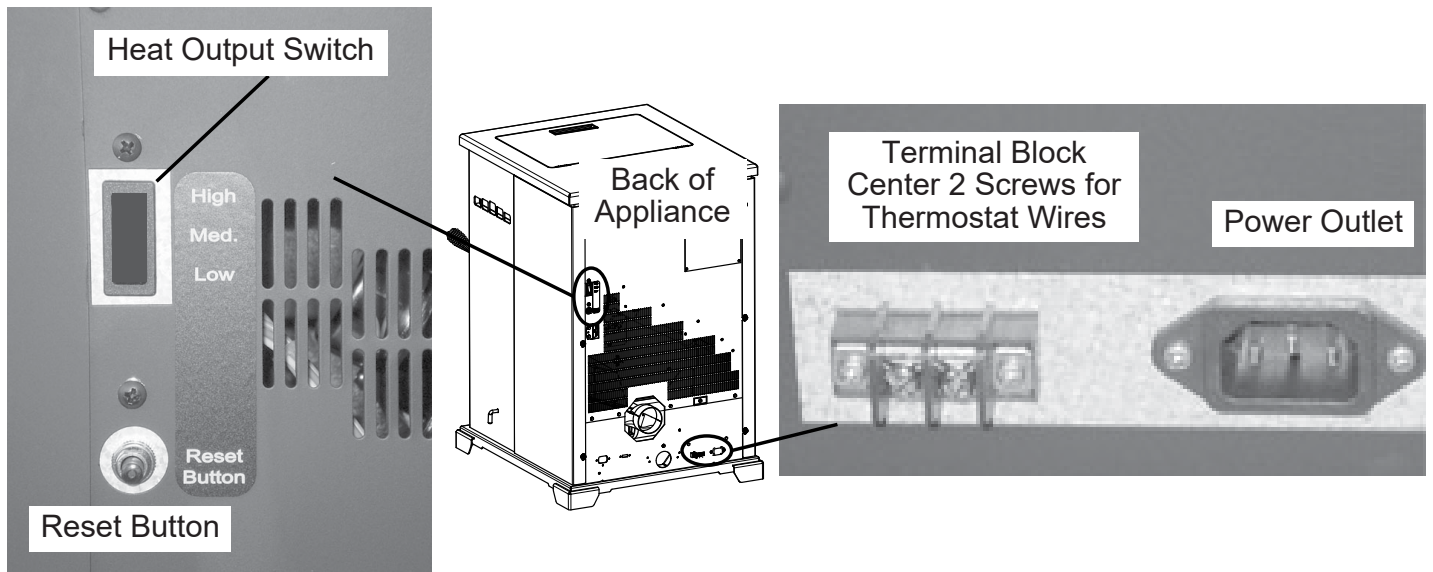

Figure 30.1

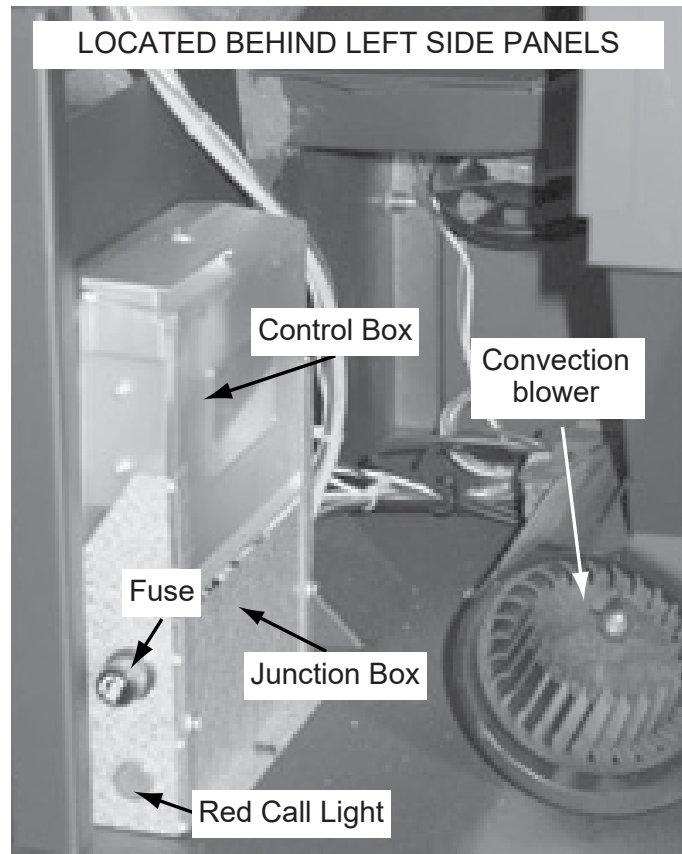

Figure 30.2

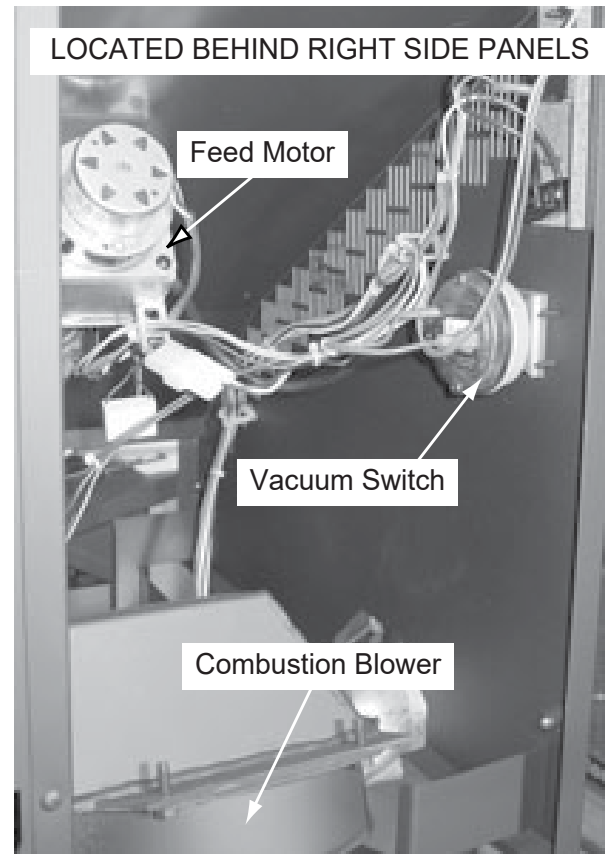

Figure 30.3

QUADRA-FIRE®

NOTHING BURNS LIKE A QUAD

CONTACT INFORMATION

Hearth & Home Technologies
 352 Mountain House Road
 Halifax, PA 17032
 Division of HNI INDUSTRIES

Please contact your Quadra-Fire dealer with any questions or concerns.
 For the number of your nearest Quadra-Fire dealer
 log onto www.quadrafire.com



CAUTION



DO NOT DISCARD THIS MANUAL

- Important operating and maintenance instructions included.
- Read, understand and follow these instructions for safe installation and operation.
- Leave this manual with party responsible for use and operation of this appliance.



We recommend that you record the following pertinent information for your heating appliance.

Date purchased/installed: _____

Serial Number: _____ Location on appliance: _____

Dealership purchased from: _____ Dealer Phone: 1() - _____

Notes: _____

This product may be covered by one or more of the following patents: (United States) 5341794, 5263471, 6688302, 7216645, 7047962 or other U.S. and foreign patents pending.



HEARTH & HOME
 technologies™