

**Model:
CFX-TV36B**

Installers Guide

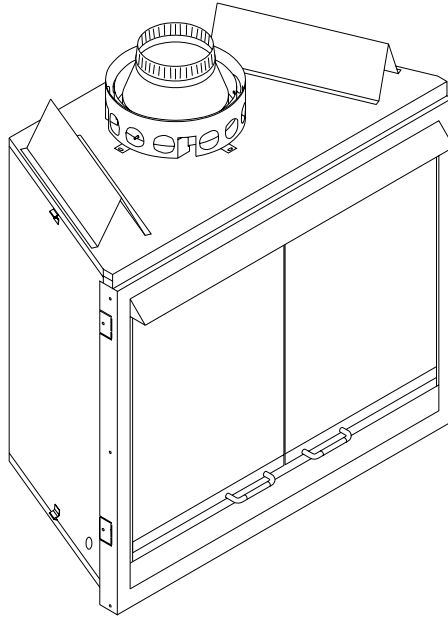

Underwriters
Laboratories Listed

WARNING: IF THE INFORMATION IN THESE INSTRUCTIONS IS NOT FOLLOWED EXACTLY, A FIRE OR EXPLOSION MAY RESULT CAUSING PROPERTY DAMAGE, PERSONAL INJURY, OR DEATH.

- Do not store or use gasoline or other flammable vapors and liquids in the vicinity of this or any other appliance.
- **What to do if you smell gas**
 - Do not try to light any appliance.
 - Do not touch any electrical switch.
 - Do not use any phone in your building.
 - Immediately call your gas supplier from a neighbor's phone. Follow the gas supplier's instructions.
 - If you cannot reach your gas supplier, call the fire department.
- Installation and service must be performed by a qualified installer, service agency, or the gas supplier.

READ THIS MANUAL BEFORE INSTALLING OR OPERATING THIS APPLIANCE. THIS *INSTALLERS GUIDE* MUST BE LEFT WITH APPLIANCE FOR FUTURE REFERENCE.

WARNING: IMPROPER INSTALLATION, ADJUSTMENT, ALTERATION, SERVICE OR MAINTENANCE CAN CAUSE INJURY OR PROPERTY DAMAGE. REFER TO THIS MANUAL. FOR ASSISTANCE OR ADDITIONAL INFORMATION CONSULT A QUALIFIED INSTALLER, SERVICE AGENCY, OR THE GAS SUPPLIER.

Please contact your Heat-N-Glo dealer for any questions or concerns. For the number of your nearest Heat-N-Glo dealer, please call 952-985-6000.

Printed in U.S.A. Copyright 2000,

Heat-N-Glo, a division of Hearth Technologies Inc.
20802 Kensington Boulevard, Lakeville, MN 55044

SAFETY AND WARNING INFORMATION

 **READ** and **UNDERSTAND** all instructions carefully before starting the installation. **FAILURE TO FOLLOW** these installation instructions may result in a possible fire hazard and will void the warranty.

 Prior to the first firing of the fireplace, **READ** the Using Your Fireplace section of the *Owners Guide*.

 **DO NOT USE** this appliance if any part has been under water. Immediately **CALL** a qualified service technician to inspect the unit and to replace any part of the control system and any gas control which has been under water.

 **THIS UNIT IS NOT FOR USE WITH SOLID FUEL.**

 Installation and repair should be **PERFORMED** by a qualified service person. The appliance and venting system should be **INSPECTED** before initial use and at least annually by a professional service person. More frequent cleaning may be required due to excessive lint from carpeting, bedding material, etc. It is **IMPERATIVE** that the unit's control compartment, burners, and circulating air passageways **BE KEPT CLEAN** to provide for adequate combustion and ventilation air.

 Always **KEEP** the appliance clear and free from combustible materials, gasoline, and other flammable vapors and liquids.

 **NEVER OBSTRUCT** the flow of combustion and ventilation air. Keep the front of the appliance **CLEAR** of all obstacles and materials for servicing and proper operations.

 Due to the high temperature, the appliance should be **LOCATED** out of traffic areas and away from furniture and draperies. Clothing or flammable material **SHOULD NOT BE PLACED** on or near the appliance.

 Children and adults should be **ALERTED** to the hazards of high surface temperature and should **STAY AWAY** to avoid burns or clothing ignition. Young children should be **CAREFULLY SUPERVISED** when they are in the same room as the appliance.

 These units **MUST** use one of the vent systems described in the Installing the Fireplace section of the *Installers Guide*. **NO OTHER** vent systems or components **MAY BE USED**.

 This gas fireplace and vent assembly **MUST** be vented directly to the outside and **MUST NEVER** be attached to a chimney serving a separate solid fuel burning appliance. Each gas appliance **MUST USE** a separate vent system. Common vent systems are **PROHIBITED**.

 **INSPECT** the external vent cap on a regular basis to make sure that no debris is interfering with the air flow.

 The glass door assembly **MUST** be in place and sealed, and the trim door assembly **MUST** be in place on the fireplace before the unit can be placed into safe operation.

 **DO NOT OPERATE** this appliance with the glass door removed, cracked, or broken. Replacement of the glass door should be performed by a licensed or qualified service person. **DO NOT** strike or slam the glass door.

 The glass door assembly **SHALL ONLY** be replaced as a complete unit, as supplied by the gas fireplace manufacturer. **NO SUBSTITUTE** material may be used.

 **DO NOT USE** abrasive cleaners on the glass door assembly. **DO NOT ATTEMPT** to clean the glass door when it is hot.

 Turn off the gas before servicing this appliance. It is recommended that a qualified service technician perform an appliance check-up at the beginning of each heating season.

 Any safety screen or guard removed for servicing must be replaced before operating this appliance.

TABLE OF CONTENTS

Safety and Warning Information	2
◆ Service Parts Lists	4
Section 1: Approvals and Codes	6
Approval Listings and Codes	6
Appliance Certification	6
Installation Codes	6
High Altitude Installations	6
Section 2: Getting Started	7
Introducing the Heat-N-Glo Gas Fireplaces	7
Pre-installation Preparation	7
Section 3: Installing the Fireplace	9
◆ Step 1 Locating the Fireplace	9
Step 2 Framing the Fireplace	9
◆ Step 3 Negative Pressure Make-up Air	10
Step 4 Installing the Vent System	11
A. Vent System Approvals	11
B. System Components	11
C. Bedroom Installation in Canada	12
D. Vent Termination	12
Step 5 Positioning, Leveling, and Securing the Fireplace	12
Step 6 The Gas Control Systems	12
Step 7 The Gas Supply Line	13
Step 8 Gas Pressure Requirements	13
Step 9 Wiring the Fireplace	14
Step 10 Finishing	15
Step 11 Installing Trim, Logs, Ember Material and Glass Doors	15
Installing the Trim	15
Positioning the Logs	15
◆ Placing the Ember Material	16
Installing Glass Doors	16
◆ Step 12 Before Lighting the Fireplace	16
Step 13 Lighting the Fireplace	16
After the Installation	16
Section 4: Maintaining and Servicing Your Fireplace	17

◆ = Contains updated information.

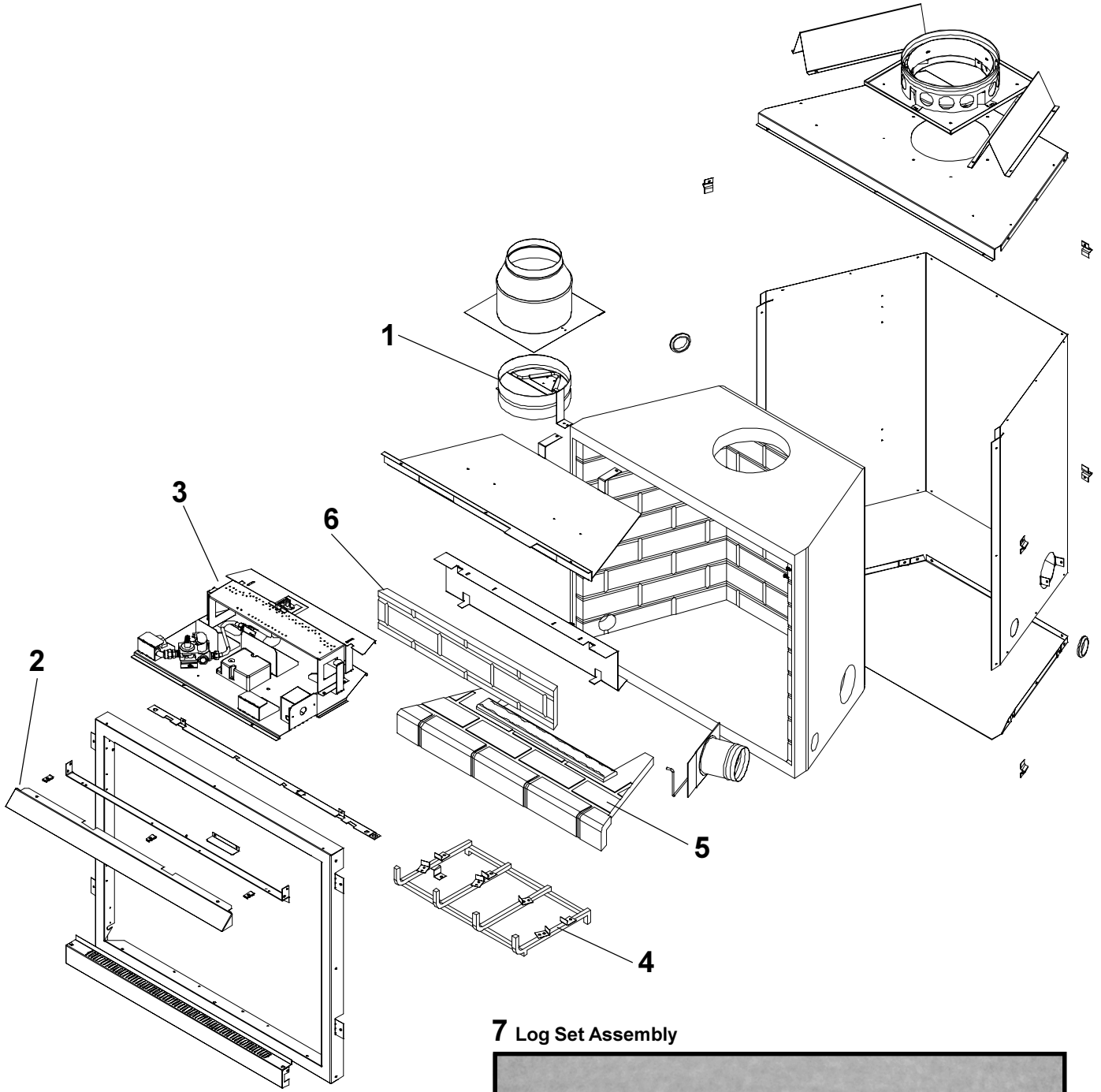

7 Log Set Assembly

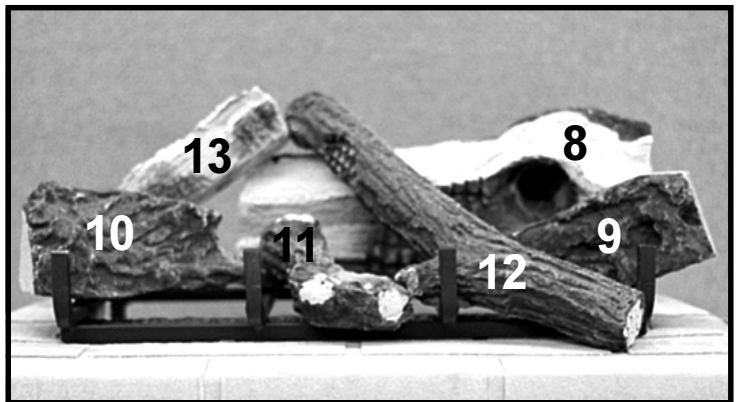

* Part number list on following page.
 * La liste des numéros de pièce se trouve à la page suivante.

CFX-TV36B-DSI (NG, LP) Service Parts List / Liste des pièces de rechange

IMPORTANT: THIS IS DATED INFORMATION. The most current information is located on your dealers VIP site. When ordering, supply serial and model numbers to ensure correct service parts.

ITEM / PIÈCE	DSI IGNITION	SERIAL # / N° DE SÉRIE	PART NUMBER / N° DE PIÈCE
	ON/OFF Wall Switch / Interrupteur mural Marche/Arrêt		SRV130-511
	Wall Switch Cover Plate / Cache de l'interrupteur mural		SRV130-512
	High Temp Limit Switch / Interrupteur de détection thermique		SRV60-531
	Burner Tube / Tube de brûleur		SRV477-312
	Burner Orifice NG (#34B) / Orifice de brûleur GN (#34B)		SRV592-800
	Burner Orifice LP (#51B) / Orifice de brûleur PL (#51B)		SRV44-801
1	Bimetallic Flue Damper / Registre de tuyau bimétallique		SRV492-110A
2	Hood / Hotte		SRV592-243
3	Burner NG, LP / Brûleur GN, PL		SRV592-174A
4	Grate Assembly / Module de Grille		SRV592-360A
5	Base Refractory / Réfractaire		SRV592-740
6	Refractory, Top / Réfractaire, Dessus		SRV592-742
7	Log Set Assembly / Jeu de Bûches		LOGS-TV36B
8	Log 1 / Bûche 1		SRV446-701
9	Log 2 / Bûche 2		SRV446-702
10	Log 3 / Bûche 3		SRV446-703
11	Log 4 / Bûche 4		SRV540-704
12	Log 5 / Bûche 5		SRV560-702
13	Log 6 / Bûche 6		SRV446-706
	Junction Box / Boîtier de raccordement		SRV100-254A
	Valve NG / Valve GN		SRV492-500
	Valve LP / Valve PL		SRV492-501
	Electrode / Électrode		SRV501-591
	Module / Module		SRV501-592
Accessories / Accessoires			
	Make-up Air Kit / Module de prise d'air de compensation		AK-CFX
	Remote Control Kit / Commande à distance		RC-STAT
	Remote Control Kit / Commande à distance		SMART-STAT
	Mesh Assembly / Module de Écran		MESH-CFX
	NG Conversion Kit / Module de conversion au GN		NGK-TV36B
	LP Conversion Kit / Module de conversion au propane		LPK-TV36B
	Cabinet Doors / Portes à battant		GDA-CFXT
	Bi-Fold Glass Door / Porte en verre pliante		GDA-CFXT-BFBK

1

Approvals and Codes

Appliance Certification

The Heat-N-Glo fireplace model discussed in this *Installers Guide* has been tested to certification standards and listed by the applicable laboratories.

Certification
MODEL: CFX-TV36B
LABORATORY: Underwriters Laboratories
TYPE: Direct Vent Gas Fireplace
STANDARD: ANSI Z21.50•CGA2.22

Installation Codes

The fireplace installation must conform to local codes. Before installing the fireplace, consult the local building code agency to ensure that you are in compliance with all applicable codes, including permits and inspections.

In the absence of local codes, the fireplace installation must conform to the National Fuel Gas Code ANSI Z223.1 (in the United States) or the CAN/CGA-B149 Installation Codes (in Canada). The appliance must be electrically grounded in accordance with local codes or, in the absence of local codes with the National Electric Code ANSI/NFPA No. 70 (in the United States), or to the CSA C22.1 Canadian Electric Code (in Canada).

This model (natural gas and propane) can be installed in a bedroom (in the United States) which has a total volume of unconfined space appropriate to the particular installation. Refer to the National Fuel Gas Code ANSI Z223.1/NFPA54

(current edition). The Uniform Mechanical Code - (current edition), and local Building Officials for the options allowed in obtaining an effective bedroom volume of unconfined space.

This model (natural gas and propane) can be installed in a bedroom (in Canada) if a thermostat (Model WH-STAT) is installed with the unit. Consult local code authorities. Detailed installation instructions for Model WH-STAT are included with the kit.

High Altitude Installations

U.L. Listed gas fireplaces are tested and approved for elevations from 0 to 2,000 feet in the U.S.A. and from 0 to 4,500 feet in Canada.

When installing this fireplace at an elevation above 2,000 feet (in the United States), it may be necessary to decrease the input rating by changing the existing burner orifice to a smaller size. Input should be reduced four percent (4%) for each 1,000 feet above sea level, unless the heating value of the gas has been reduced, in which case this general rule will not apply. To identify the proper orifice size, check with the local gas utility.

When installing this fireplace at an elevation between 2,000 and 4,500 feet (in Canada), the input rating must be reduced by ten percent (10%).

When installing this fireplace at an elevation above 4,500 feet (in Canada), check with local authorities.

Consult your local gas utility for assistance in determining the proper orifice for your location.



Heat-N-Glo Quality
Systems registered
by SGS ICS

2

Getting Started

Introducing the Heat-N-Glo Gas Fireplaces

This gas fireplace is designed to operate with all exhaust gases expelled to the outside of the building. The vent system for this fireplace must be 6-inch Class B chimney as shown in the venting section of this manual.

The information contained in this *Installers Guide*, unless noted otherwise, applies to all models and gas control systems. Gas fireplace diagrams, including the dimensions, are shown in this section.

Pre-install Preparation

This gas fireplace and its components are tested to perform only when installed in accordance with this *Installers Guide*. Report to your dealer any parts damaged in shipment, particularly the condition of the glass. **Do not install any unit with damaged, incomplete, or substitute parts.**

The vent system components are shipped in separate packages. The gas logs are shipped with the unit and installed per log instructions.

Read all of the instructions before starting the installation. Follow these instructions carefully during the installation to ensure maximum safety and benefit. Failure to follow these instructions will void the owner's warranty and may present a fire hazard.



WARNING: IF THERE IS ANY NOTICEABLE DAMAGE TO THE FIBER FIREBOX PLEASE CONTACT YOUR DEALER FOR FURTHER INSTRUCTIONS.

The Heat-N-Glo Warranty will be voided by, and Heat-N-Glo disclaims any responsibility for, the following actions:

- Installation of any damaged fireplace or vent system component.
- Modification of the fireplace or vent system components.
- Installation other than as instructed by Heat-N-Glo.
- Improper positioning of the gas logs or the glass door.
- Installation and/or use of any component part not manufactured and approved by Heat-N-Glo, notwithstanding any independent testing laboratory or other party approval of such component part or accessory.

ANY SUCH ACTION MAY POSSIBLY CAUSE A FIRE HAZARD.

When planning a fireplace installation, it's necessary to determine:

- Where the unit is to be installed.
- The vent system configuration to be used.
- Gas supply piping.
- Electrical wiring.
- Framing and finishing details.
- Whether optional accessories—devices such as a remote control—are desired.

If the fireplace is to be installed on carpeting or tile, or on any combustible material other than wood flooring, the fireplace should be installed on a metal or wood panel that extends the full width and depth of the fireplace.

3

Installing the Fireplace

Step 1. Locating the Fireplace

The diagram below shows space and clearance requirements for locating a fireplace within a room.

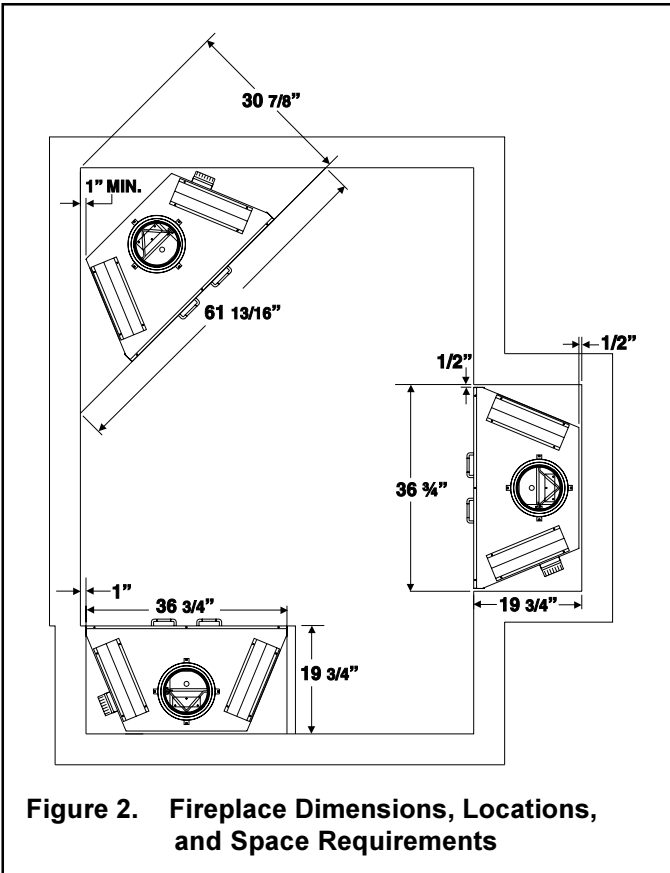

Figure 2. Fireplace Dimensions, Locations, and Space Requirements

Clearance Requirements

The top, back, and sides of the fireplace are defined by stand-offs. The minimum clearance to a perpendicular wall extending past the face of the fireplace is one inch (25 mm). The back of the fireplace may be recessed 18 3/4 inches (476 mm) into combustible construction.

Minimum Clearances from the Fireplace to Combustible Materials		
	Inches	mm
Glass Front	36	914
Floor	0	0
Rear	1/2	13
Sides	1/2	13
Top	4	102
Ceiling*	50	1270

* The clearance to the ceiling is measured from the top of the unit, excluding the standoffs (see Figure 11).

The distance from the unit to combustible construction is to be measured from the unit outer wrap surface to the combustible construction, **NOT** from the screw heads that secure the unit together.

Minimum Clearances from the Class B Chimney Vent Pipe to Combustible Materials is 1 inch (25mm) all around the pipe.

Step 2. Framing the Fireplace

Fireplace framing can be built before or after the fireplace is set in place. Framing should be positioned to accommodate wall coverings and fireplace facing material. The diagram below shows framing reference dimensions.

CAUTION: MEASURE FIREPLACE DIMENSIONS AND VERIFY FRAMING METHODS AND WALL COVERING DETAILS BEFORE FRAMING.

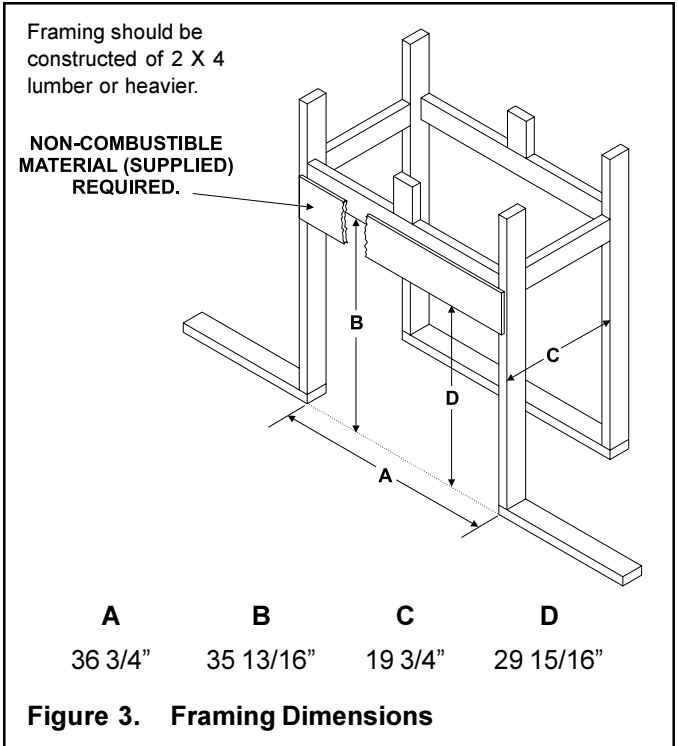

Figure 3. Framing Dimensions

NOTE: You must place the supplied (required) non-combustible board on the top front face of the unit once the unit is in place. See Figure 11.

Step 3. Negative Pressure Make-up Air

Negative Pressure warning: When negative pressure is present, an atmospherically vented fireplace may not function properly and it may down draft. In the case of a gas appliance, spillage of the combustion gases may occur. **This may create a dangerous carbon monoxide situation in the house.**

The causes of negative pressure to a house can include the following:

- Stack effect in the building.
- Exhaust only appliances (mechanically and atmospherically vented).
- Inadequate make-up air (which is increasingly more prevalent in new construction).

This unit does contain a high temperature limit switch that will turn off the fireplace if the flue damper is not open or in a negative pressure situation.

NOTE: This fireplace will operate correctly only if adequate ventilation is provided to allow proper draft to the fireplace system. Heat-N-Glo assumes no responsibility for the improper performance of the fireplace system caused by inadequate draft due to environmental conditions, down drafts, tight sealing construction of the structure, or mechanical exhausting devices which create a negative air pressure within the structure where the fireplace is located.

It is recommended that all natural venting non-air tight gas fireplaces have outside air connected to them. It is also recommended that the building be mechanically or passively balanced to allow atmospherically vented appliances, such as top vented gas fireplaces with draft hoods, to draft properly. If the home experiences negative pressure or is likely to experience negative pressure, connection to an outside air source is mandatory.

Installing Outside Make-up Air:

This unit is equipped to accept outside air. It is **RECOMMENDED** that an AK-CFX air kit be used with this appliance. The 4-inch (102mm) side collar for the air kit is provided on the side of the fireplace. See Figure 4. Detailed installation instructions for the Model AK-CFX Outside Air kit are found in the kit. Follow these instructions to complete the installation.

This appliance also contains a make-up air damper which is manually opened and closed from inside of the firebox. Pull forward to open, push back to close. See Figure 4.

CAUTION: DO NOT OPERATE THE AIR DAMPER WHEN UNIT IS HOT.

WARNING: IN A NEGATIVE PRESSURE CONDITION (LIKELY TO OCCUR IN NEW HOMES THAT DO NOT HAVE ADEQUATE MAKE-UP AIR) THE OUTSIDE AIR KIT MUST BE INSTALLED TO OBTAIN PROPER PERFORMANCE AND TO HELP PREVENT SPILLAGE OF COMBUSTION GASES.

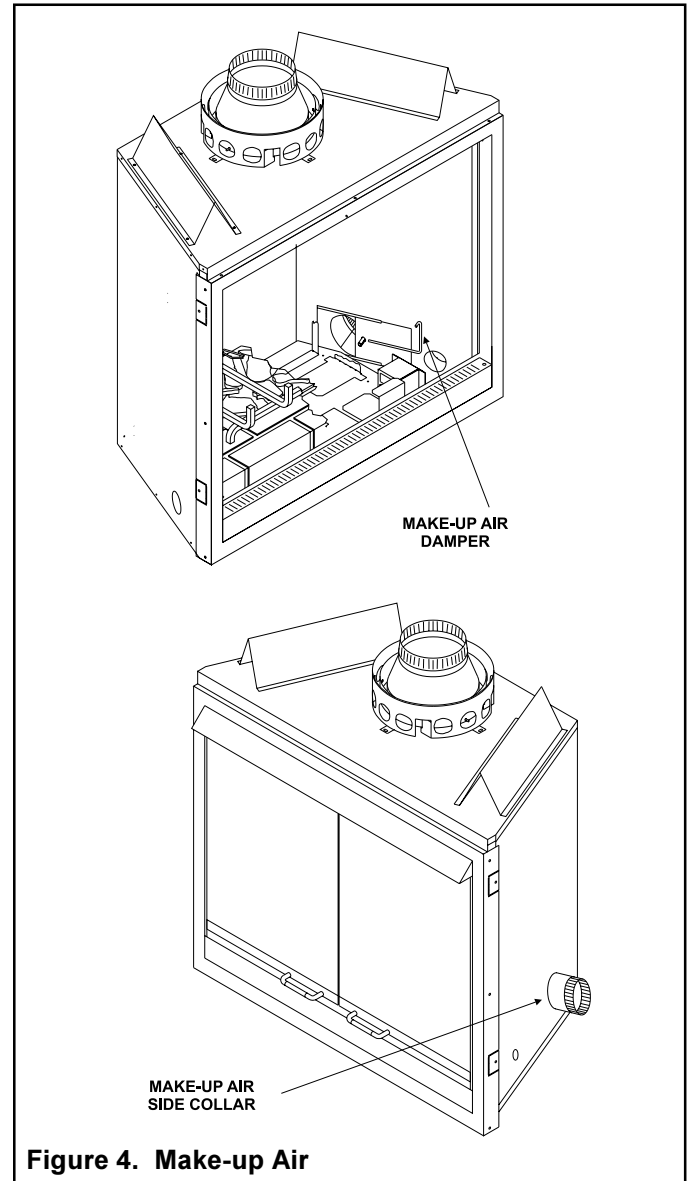

Figure 4. Make-up Air

Step 4. Installing the Vent System

A. Vent System Approvals

Model CFX-TV36B is approved to use 6-inch (152mm) diameter B-type vent. B-type vent must be used when the vent system is within combustible construction.

The flame and ember appearance may vary based on the type of fuel burned and the venting configuration used.

B. System Components.

Vent System Configuration

RISE TO RUN RATIO = 2:1

MAXIMUM TOTAL HORIZONTAL RUN = 15 FT.

MINIMUM TOTAL VERTICAL RISE = 9 FT.

MAXIMUM NO. OF ELBOWS: 2 - 90° or 4 - 45°

Plan and install the vent system using the parameters shown above.

 **WARNING: YOU MUST NOT EXCEED THESE PARAMETERS.**

Connect a B-Type vent component to the flue outlet collar. Look at the vent pipe through the holes in the 10 5/8" ring to check that the vent pipe is attached.

NOTE: It is always better to first attach a straight section of vent to the unit before attaching an elbow. Avoid using elbows in the vent system if possible.

Continue to add vent components, until the vent run is completed.

 **WARNING: YOU MUST NOT EXCEED A TOTAL MAXIMUM HORIZONTAL RUN OF 15 FEET FOR THE ENTIRE VENT SYSTEM.**

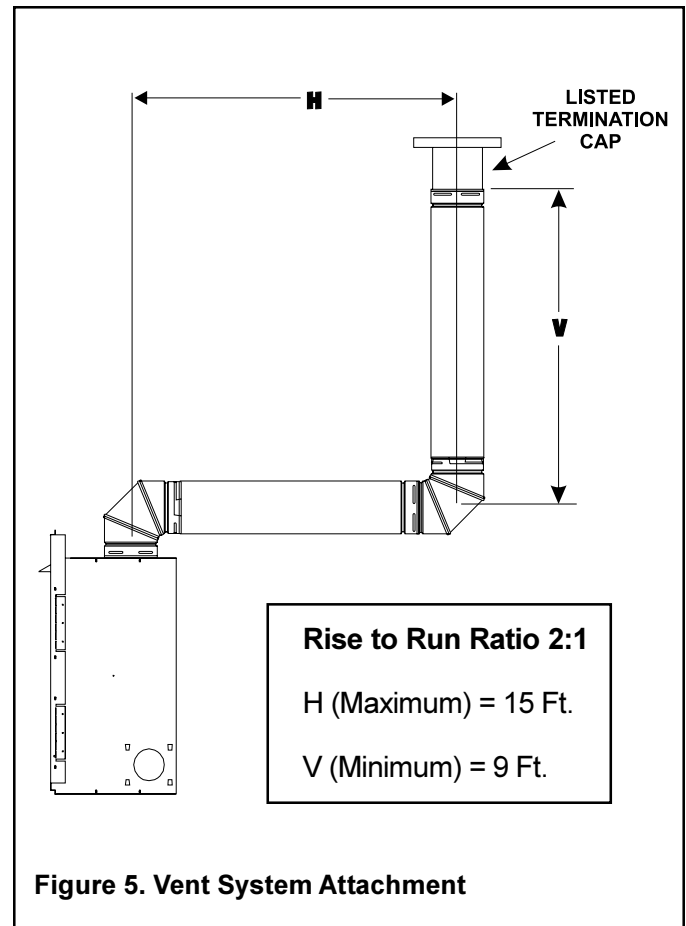



Figure 5. Vent System Attachment

NOTE: The vent termination must be in a vertical position and the termination cap must be listed for the vent pipe used.

Consult local building code officials and codes for proper vent system installations.

 **WARNING: THIS GAS FIREPLACE MUST NEVER BE VENTED BY CONNECTING TO A CHIMNEY FLUE SERVING A SEPARATE SOLID FUEL BURNING APPLIANCE.**

C. Bedroom Installation in Canada

This model **MUST NOT** be vented into a vent system installed exterior to a building. The part of the vent system above the roof line can be exterior to the building.

D. Vent Termination



WARNING: MAJOR U.S. BUILDING CODES SPECIFY MINIMUM CHIMNEY AND/OR VENT HEIGHT ABOVE THE ROOF TOP. THESE MINIMUM HEIGHTS ARE NECESSARY IN THE INTEREST OF SAFETY. FIGURE 6 AND TABLE SHOW MINIMUM HEIGHTS, PROVIDED THE TERMINATION CAP IS AT LEAST 8-Feet FROM A VERTICAL WALL.

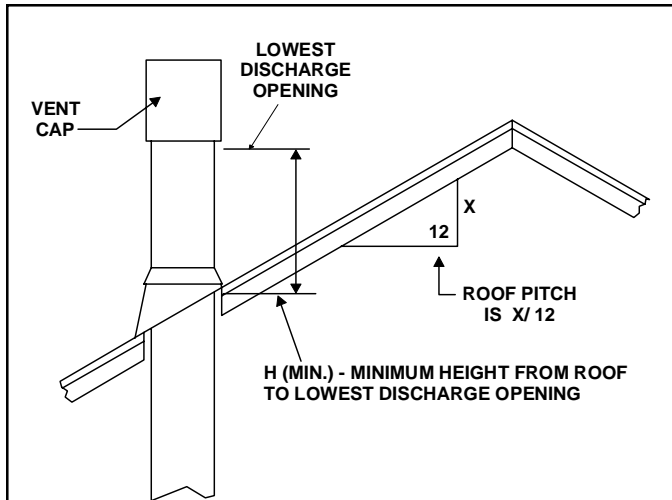

<u>ROOF PITCH</u>	<u>H (MIN.) FT.</u>
FLAT TO 6/12	1.0
6/12 TO 7/12	1.25
OVER 7/12 TO 8/12	1.5
OVER 8/12 TO 9/12	2.0
OVER 9/12 TO 10/12	2.5
OVER 10/12 TO 11/12	3.25
OVER 11/12 TO 12/12	4.0
OVER 12/12 TO 14/12	5.0
OVER 14/12 TO 16/12	6.0
OVER 16/12 TO 18/12	7.0
OVER 18/12 TO 20/12	7.5
OVER 20/12 TO 21/12	8.0

Figure 6. Vent Termination

Step 5. Positioning, Leveling, and Securing the Fireplace

To properly position, level, and secure the fireplace:

- Place the fireplace into position (see Figure 7).
- Level the fireplace from side to side and from front to back.
- Shim the fireplace with non-combustible material, such as sheet metal, as necessary.
- Secure the fireplace to the framing by nails or screws using nailing tabs.

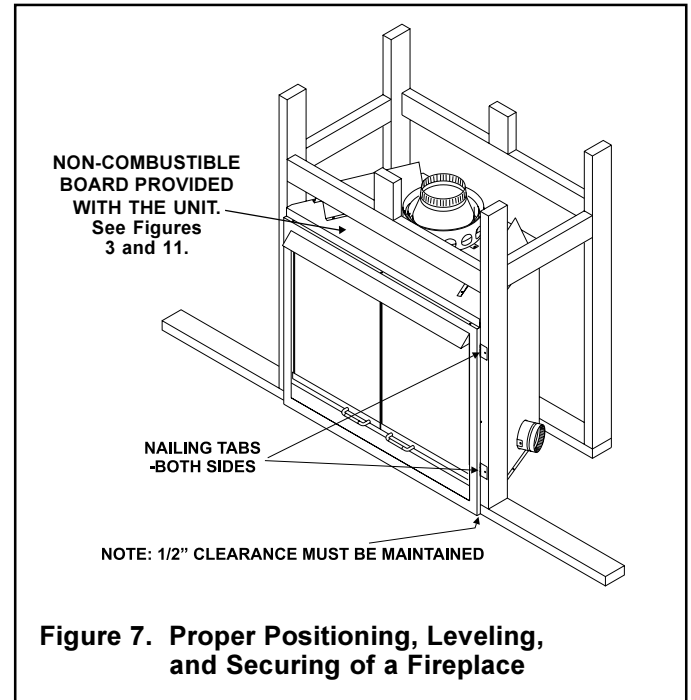

Figure 7. Proper Positioning, Leveling, and Securing of a Fireplace

Step 6. The Gas Control Systems



WARNING: THIS UNIT IS NOT FOR USE WITH SOLID FUEL.

This model uses a *Direct Spark Ignition (DSI) gas control system*.

Direct Spark Ignition (DSI) System

The DSI system includes a 110VAC control valve, electronic module, and spark ignitor/flame sensor.



WARNING: 110-120 VAC MUST BE WIRED TO THE FIREPLACE JUNCTION BOX IN A DSI SYSTEM.

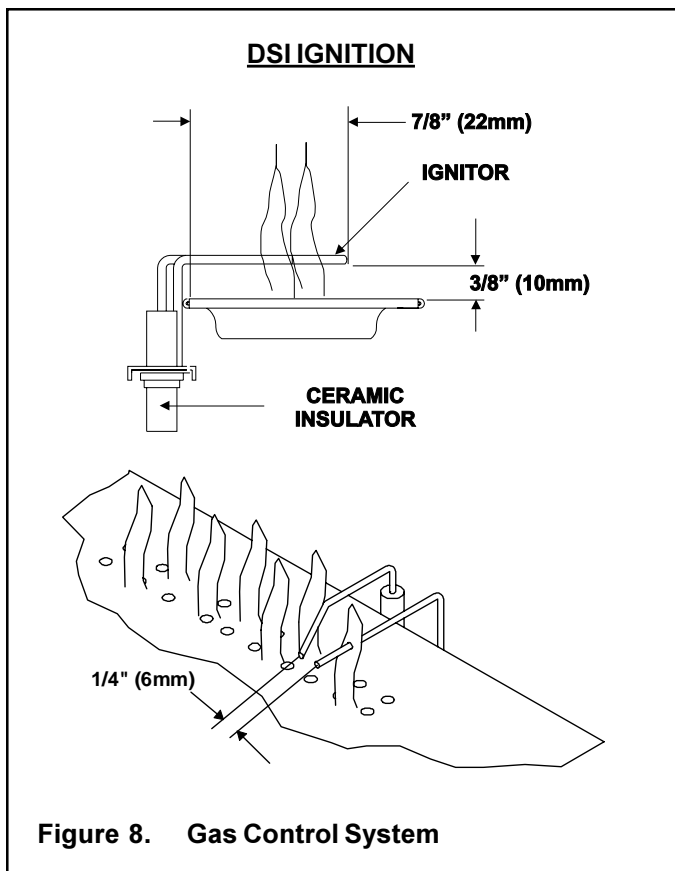

Figure 8. Gas Control System

Step 7. The Gas Supply Line

NOTE: Have the gas supply line installed by a qualified service technician in accordance with all building codes.

NOTE: Before the first firing of the fireplace, the gas supply line should be purged of any trapped air.

NOTE: Consult local building codes to properly size the gas supply line leading to the 1/2 inch (13 mm) hook-up at the unit.

This gas fireplace is designed to accept a 1/2 inch (13 mm) gas supply line.

To install the gas supply line:

- A listed 1/2 inch (13 mm) manual shut-off valve and a listed flexible gas connector are connected to the 3/8 inch (10 mm) inlet of the control valve.
- Locate the gas line access hole in the outer casing of the fireplace.
- Access the fireplace controls compartment, insert the gas supply line through the gas line hole, and connect it to the shut-off valve.
- When attaching the pipe, support the control so that the lines are not bent or torn.
- After the gas line installation is complete, use a soap solution to carefully check all gas connections for leaks.



WARNING: DO NOT USE AN OPEN FLAME TO CHECK FOR GAS LEAKS.

- Insert insulation from the outside of the fireplace and pack the insulation tightly to totally seal between the pipe and the outer casing.
- At the gas line access hole the gap between the supply piping and gas access hole can be plugged with non-combustible insulation to prevent cold air infiltration.

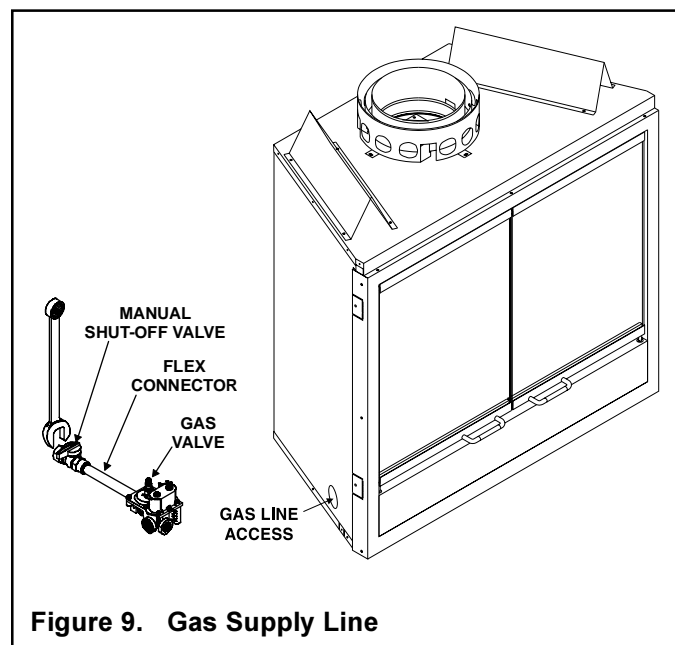

Figure 9. Gas Supply Line

Step 8. Gas Pressure Requirements

Pressure requirements for Heat-N-Glo gas fireplaces are shown in the table below.

Pressure	Natural Gas	Propane
Minimum Inlet Pressure	5.0 inches w.c.	11.0 inches w.c.
Maximum Inlet Gas Pressure	14.0 inches w.c.	14.0 inches w.c.
Manifold Pressure	3.5 inches w.c.	10.0 inches w.c.

A one-eighth (1/8) inch (3 mm) N.P.T. plugged tapping is provided on the inlet and outlet side of the gas control for a test gauge connection to measure the manifold pressure.

The fireplace and its individual shut-off valve must be disconnected from the gas supply piping system during any pressure testing of the system at test pressures in excess of one-half (1/2) psig (3.5 kPa).

The fireplace must be isolated from the gas supply piping system by closing its individual shut-off valve during any pressure testing of the gas supply piping system at test pressures equal to or less than one-half (1/2) psig (3.5 kPa).

Step 10. Finishing

Figure 11 shows the minimum vertical and corresponding maximum horizontal dimensions of fireplace mantels or other combustible projections above the top front edge of the fireplace. See Figures 2 and 3 for other fireplace clearances.

Only non-combustible materials may be used to cover the black fireplace front, sides, top and bottom.

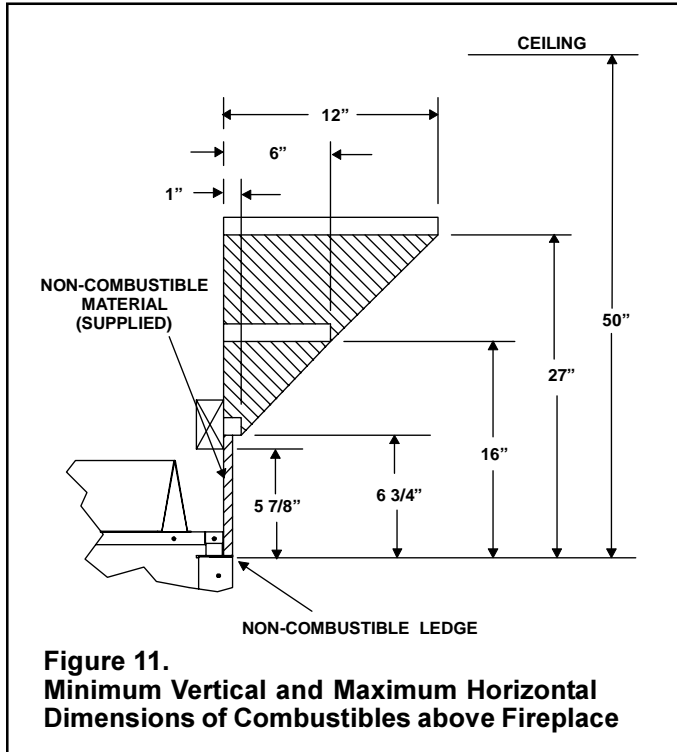

Figure 11.
Minimum Vertical and Maximum Horizontal Dimensions of Combustibles above Fireplace

CAUTION: IF JOINTS BETWEEN THE FINISHED WALLS AND THE FIREPLACE SURROUND (TOP AND SIDES) ARE SEALED, A 300° F. MINIMUM SEALANT MATERIAL MUST BE USED. THESE JOINTS ARE NOT REQUIRED TO BE SEALED. ONLY NON-COMBUSTIBLE MATERIAL (USING 300° F. MINIMUM ADHESIVE, IF NEEDED) CAN BE APPLIED AS FACING TO THE FIREPLACE SURROUND. SEE THE DIAGRAM BELOW.

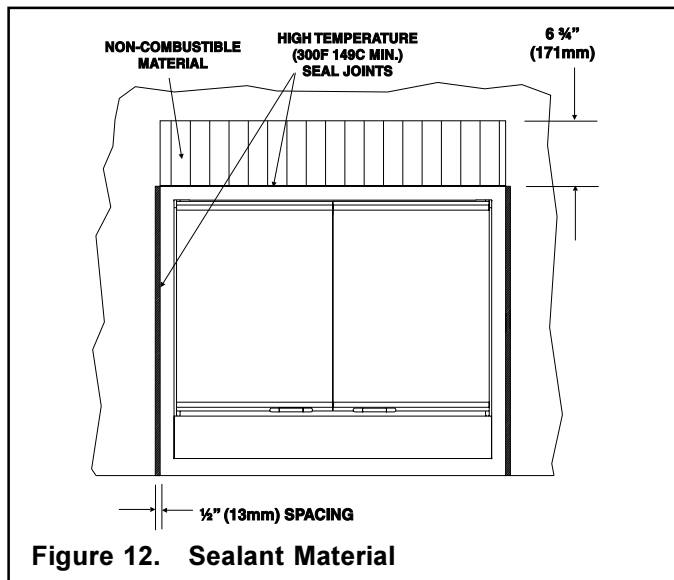

Figure 12. Sealant Material

Hearth Extensions

A hearth extension may be desirable for aesthetic reasons. However, ANSI or CAN/CGA testing standards **do not** require hearth extensions for gas fireplace appliances.



WARNING: IF NON-COMBUSTIBLE MATERIAL SUCH AS BRICK IS USED TO COVER THE BLACK FACE OF THE FIREPLACE SURROUNDS, THE JOINTS BETWEEN THE FACING MATERIAL (BRICK, ETC.) AND THE FIREPLACE MUST BE THOROUGHLY SEALED OR A FIRE COULD RESULT.

Step 11. Installing Trim, Logs, Ember Material and Glass Doors

Installing the Trim

Combustible materials may be brought up to the specified clearances on the side and top front edges of the fireplace, but **MUST NEVER** overlap onto the front face. The joints between the finished wall and the fireplace top and sides can only be sealed with a 300° F (149° C) minimum sealant.

Install optional marble and brass trim surround kits as desired. Marble, brass, brick, tile, or other non-combustible materials can be used to cover up the gap between the sheet rock and the fireplace.

Positioning the Logs

The logs for model CFX-TV36B have been packaged separately. Refer to the installation instructions that accompany the logs. **Save the log instructions with this manual.**

If sooting occurs, the logs might need to be repositioned slightly to avoid excessive flame impingement.

Placing the Ember Material

Ember material is shipped with this gas fireplace. The bag labeled Golden Ember (GE-93) is flame colorant material. The bag labeled Glowing Ember (050-721) is standard glowing ember material. To place the ember material:

- Open or remove the glass door from the unit.
- Place dime size pieces of ember material about 1/2 inch apart near port holes in burner top. Do NOT press embers into burner ports. Cover the top of the burner with a single layer of ember material. For best performance do NOT place embers on the ports at the rear of the burner (see Figure 13).
- Save the remaining ember materials for use during fireplace servicing. The bag of embers provided is sufficient for 3 to 5 applications.
- Replace or close the glass door.

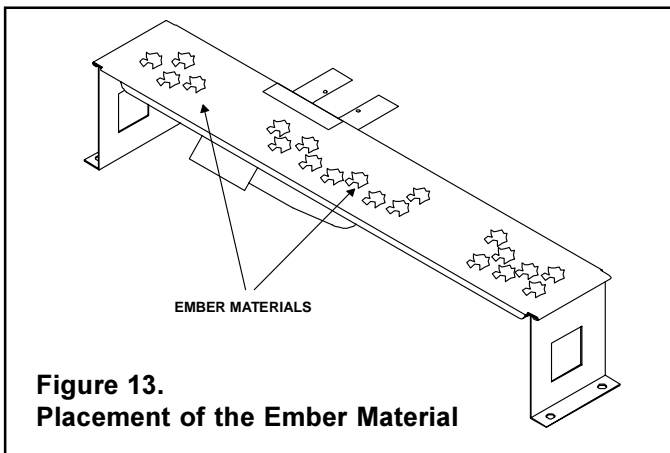

Figure 13.
Placement of the Ember Material

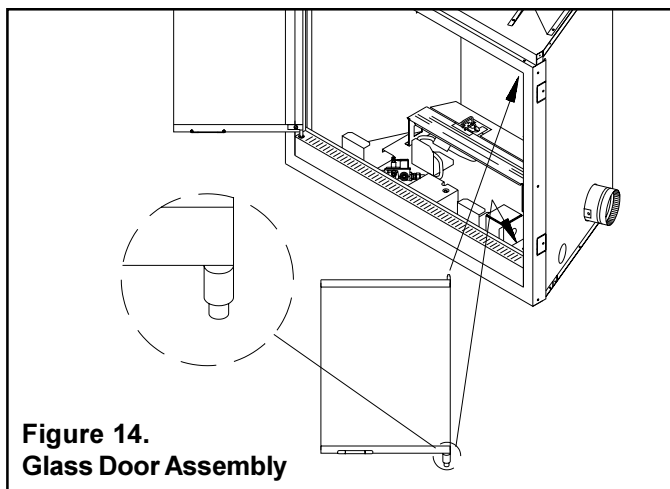

Figure 14.
Glass Door Assembly

Installing Glass Doors *(Optional)

- Attach u-channel and door clips on top door ledge per installation instructions. See Figure 14.
- Slide bottom door shaft into the hole on bottom door panel. Slide top door shaft down spring clip until the door shaft positions in spring clip hole.

NOTE: Some door styles may have different assembly methods, so follow the instructions provided with the doors.

- The doors may be used both **FULLY** open or **FULLY** closed.
- * **PLEASE NOTE:** Glass doors are an optional component and are not required.

GLASS SPECIFICATIONS:

CFX-TV36B 22 1/4" x 33 3/4" TEMPERED

The glass door assembly **SHALL ONLY** be replaced as a complete unit, as supplied by the gas fireplace manufacturer. **NO SUBSTITUTE** material may be used.

Step 12. Before Lighting the Fireplace

Before lighting the fireplace, be sure to do the following:

Remove all paperwork from underneath the fireplace.

Review safety warnings and cautions

- Read the **Safety and Warning Information** section at the beginning of this *Installers Guide*.

Double-check for gas leaks

- Before lighting the fireplace, double-check the unit for possible gas leaks.

Double-check vent terminations and front grilles for obstructions.

- Before lighting the fireplace, double-check the unit for possible obstructions that could be blocking the vent termination or the front of the fireplace.

Double-check for faulty components

- Any component that is found to be faulty **MUST BE** replaced with an approved component. Tampering with the fireplace components is **DANGEROUS** and voids all warranties.

A small amount of air will be in the gas supply lines. When first lighting the fireplace, it will take a few minutes for the lines to purge themselves of this air. Once the purging is complete, the fireplace will light and will operate normally.

Subsequent lightings of the fireplace will not require this purging of air from the gas supply lines, **unless the manual shut-off valve has been turned to the OFF position**, in which case the air would have to be purged.

NOTE: The fireplace should be run for 8 hours on the initial start-up. This will help to cure the chemicals used in the paint and logs.

Step 13. Lighting the Fireplace

You've reviewed all safety warnings, you've checked the fireplace for gas leaks, you know the vent system is unobstructed, and you've checked for faulty components. Now you're ready to light the fireplace.

 **WARNING: PLEASE REFER TO THE USER'S MANUAL FOR ALL CAUTIONS, SAFETY, AND WARNING INFORMATION PERTAINING TO THE LIGHTING AND OPERATION OF THE FIREPLACE.**

After the Installation

 **LEAVE THIS INSTALLATION MANUAL WITH THE APPLIANCE FOR FUTURE REFERENCE.**

4

Maintaining and Servicing Your Fireplace

Fireplace Maintenance

Although the frequency of your fireplace servicing and maintenance will depend on use and the type of installation, you should have a qualified service technician perform an appliance check-up at the beginning of each heating season. See the table below for specific guidelines regarding each fireplace maintenance task.

IMPORTANT: TURN OFF THE GAS BEFORE SERVICING YOUR FIREPLACE.

Replacing old ember material

Frequency: Once annually, during the checkup.

By: Qualified service technician.

Task: Brush away loose ember material near the burner. Replace old ember material with new dime-size and shape pieces of Golden Ember (DE-93) and Glowing Ember (050-721). New ember material should be placed alternately on top of the burner - a layer of Golden Ember, a layer of Glowing Ember, and so on. Save the remaining ember material and repeat this procedure at your next servicing. For more information, see **Placing Ember Material**.

Cleaning Burner and Controls

Frequency: Once annually.

By: Qualified service technician.

Task: Brush or vacuum the control compartment, fireplace logs and burner areas surrounding the logs.

Checking Flame Patterns, Flame Height

Frequency: Periodically.

By: Qualified service technician/Home owner.

Task: Make a visual check of your fireplace's flame patterns. Make sure the flames are steady - not lifting or floating. See Figure 15. The flame sensor (DSI) tips should be covered with flame. See Figure 16.

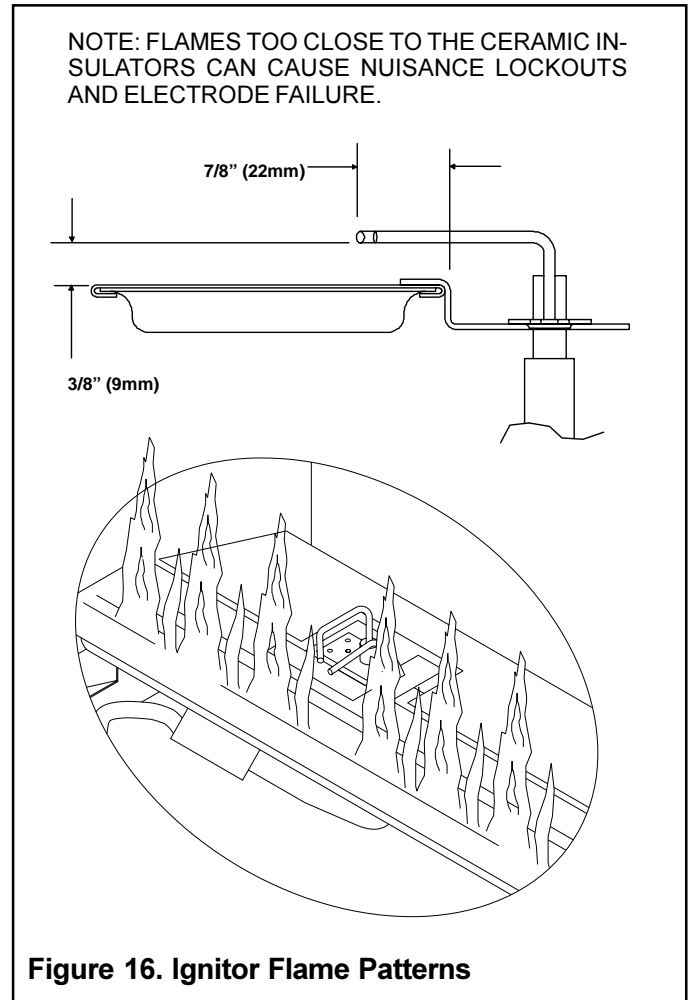
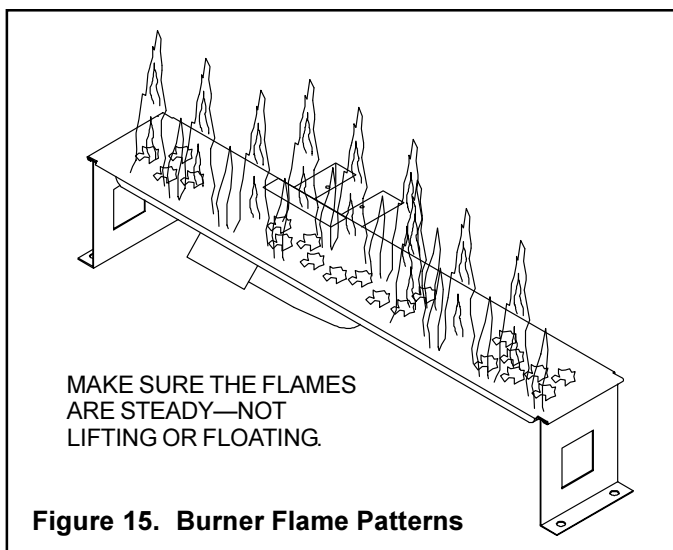

Checking Vent System

Frequency: Before initial use and at least annually thereafter, more frequently if possible.

By: Qualified service technician/Home owner.

Task: Inspect the external vent cap on a regular basis to ensure that no debris is interfering with the flow of air. Inspect entire vent system for proper function.

Cleaning Glass Door

Frequency: As necessary

By: Home owner.

Task: Clean as necessary, particularly after adding new ember (flame colorant) material. Film deposits on the inside of the glass door should be cleaned off using a household glass cleaner. **NOTE: DO NOT handle or attempt to clean the door when it is hot and DO NOT use abrasive cleaners.**