



heatilator
The first name in fireplaces

Heatilator Inc.
 1915 W. Saunders Street
 Mt. Pleasant, IA 52641
 a HON INDUSTRIES company

This appliance has been retired.
 Service parts pages within have been removed.
 For replacement parts, please refer to the individual
 service parts list located on the brand websites.

CGC100 SERIES (CGC100, CGC100E, CGC100L) INSTALLATION & OPERATING INSTRUCTIONS

I. LISTINGS AND CODE APPROVALS

These gas appliances, CGC100E (with electronic direct spark ignition) and CGC100 & GC100L (standing safety pilot ignition) have been CERTIFIED by the Canadian Gas Association for installation and operation in Canada as described in these Installation & Operating Instructions. All components are CGA or CSA safety certified.

Check with your local building code agency before you begin installation to ensure compliance with local codes, including the need for "permits" and follow-up inspections. If any problems are encountered regarding code approvals, or if you wish clarification of any of the instructions contained here, contact your local distributor/dealer, or Customer Relations Department, Heatilator Inc., 1915 W. Saunders Street, Mt. Pleasant, Iowa 52641. HEATILATOR® is a registered trademark of Heatilator Inc., a HON INDUSTRIES company.

FOR YOUR SAFETY

WHAT TO DO IF YOU SMELL GAS:

- DO NOT TRY TO LIGHT ANY APPLIANCE.
- DO NOT TOUCH ANY ELECTRICAL SWITCH; DO NOT USE ANY PHONE IN YOUR BUILDING.
- IMMEDIATELY CALL YOUR GAS SUPPLIER FROM A NEIGHBOR'S PHONE. FOLLOW THE GAS SUPPLIER'S INSTRUCTIONS.
- IF YOU CANNOT REACH YOUR GAS SUPPLIER, CALL THE FIRE DEPARTMENT.

FOR YOUR SAFETY

DO NOT STORE OR USE GASOLINE OR OTHER FLAMMABLE VAPORS AND LIQUIDS IN THE VICINITY OF THIS OR ANY OTHER APPLIANCE.

WARNING

IMPROPER INSTALLATION, ADJUSTMENT, ALTERATION, SERVICE OR MAINTENANCE CAN CAUSE INJURY OR PROPERTY DAMAGE. REFER TO THIS MANUAL. FOR ASSISTANCE OR ADDITIONAL INFORMATION CONSULT A QUALIFIED INSTALLER, SERVICE AGENCY OR THE GAS SUPPLIER.

Do not use this appliance if any part has been under water. Immediately call a qualified service technician to inspect the appliance and to replace any part of the control system and any gas control which has been under water.

CGC100 SERIES GAS APPLIANCES

Figure 1

II. GENERAL INFORMATION

This installation must conform with local codes or, in the absence of local codes, with the National Fuel Gas Code, ANSI Z223.1-1988 or, in Canada, current CAN/CGA-B149.1 and B149.2 installation codes.

INSTALLATION AND REPAIR SHOULD BE DONE BY A QUALIFIED SERVICE PERSON. THE APPLIANCE SHOULD BE INSPECTED BEFORE USE AND AT LEAST ANNUALLY BY A QUALIFIED SERVICE PERSON. MORE FREQUENT CLEANING MAY BE REQUIRED DUE TO EXCESSIVE LINT FROM CARPETING, BEDDING MATERIAL, ETC. IT IS IMPERATIVE THAT CONTROL COMPARTMENTS, BURNERS AND CIRCULATING AIR PASSAGEWAYS OF THE APPLIANCE BE KEPT CLEAN.

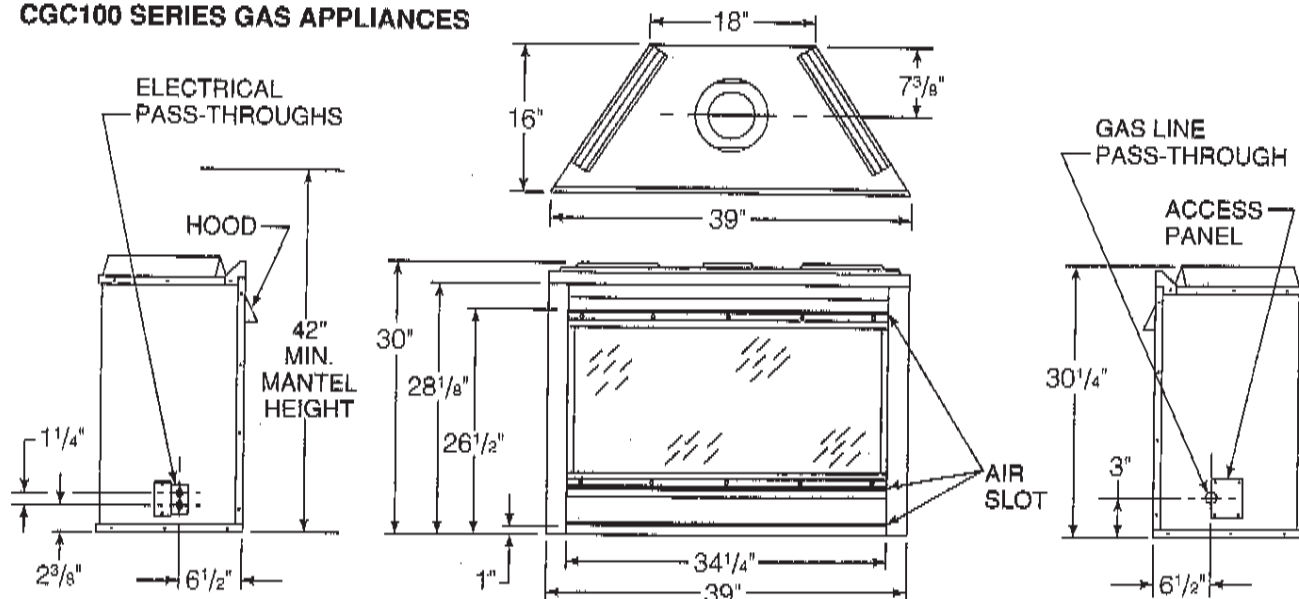
Provide adequate clearances around the air openings into the combustion chamber and adequate accessibility clearances for servicing and proper operation.

Minimum clearances to combustibles are: Top of unit 0", Floor 0", Back 1/2", Sides 1/2", Ceiling 30".

Minimum clearances to venting are: Top 3", Sides 1", Bottom 1".

Minimum mantel height: 42" from Base of appliance.

The appliance must be installed on a flat, solid, continuous surface (i.e. wood, metal, concrete).

Provide for adequate combustion and ventilation air.

For Natural Gas, the minimum inlet gas supply pressure is 4.5 inches water column, and the maximum inlet gas pressure is 11.0 inches water column, for the purpose of input adjustment. Input rate is 22,500 BTU/Hr. For Propane Gas, the inlet gas supply pressure must be at least 11.0 inches water column minimum to 14.0 water column inches maximum.

A 1/8" NPT plugged tapping is provided on the gas control valve, near the outlet to the Main Burner immediately upstream of the gas supply connection to the appliance, accessible for a test gage connection.

For high elevation, refer to ANSI Z223.1-1988, Appendix F, for resizing orifice. In Canada, certified to 0-4500 feet above sea level.

DUE TO HIGH TEMPERATURES, THE APPLIANCE SHOULD BE LOCATED OUT OF TRAFFIC AND AWAY FROM FURNITURE AND DRAPERIES.

WARNING: THIS APPLIANCE MAY ONLY USE THE DIRECT VENT CHIMNEY SYSTEM SUPPLIED WITH THE UNIT AND MUST NOT BE CONNECTED TO A CHIMNEY FLUE SERVICING A SEPARATE SOLID FUEL OR GAS FUEL BURNING APPLIANCE.

III. FIREPLACE LOCATIONS, SPACE AND CONSTRUCTION REQUIREMENTS

A CGC100 Series gas appliance can be installed in a wide variety of ways and will fit nearly any room layout. It may be installed in a recessed position, framed out into the room, or across a corner. The unit may be installed at a height level with the floor, or it can be raised up from the floor to enhance its visual impact. Figure 2 illustrates a variety of ways the appliance may be located in a room. The Natural Gas units are also certified for installation in a bed room or bed/sitting room.

Proper clearances to combustible sidewalls, as illustrated in Figure 2, must be maintained.

NOTE: If optional Fan (FK4) or Hand Held Remote Control (RC4 or RC5) are to be used, wiring must be done prior to finishing to avoid reconstruction.

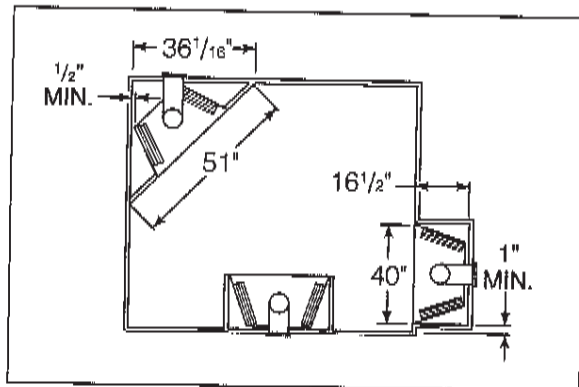

Figure 2

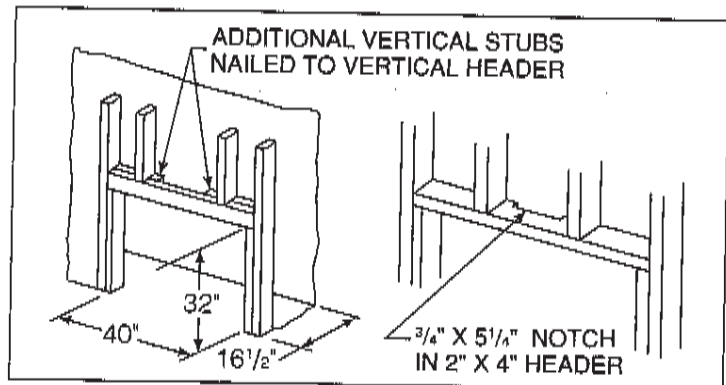

Figure 3

IV. STEP-BY-STEP INSTALLATION

STEP 1 - FRAMING

The appliance will fit a framed opening of 40" wide x 32" tall. The cavity depth must be no less than 16 1/2". See Figure 3. **NOTE: One inch minimum air space clearance must be maintained around the chimney. This will require special header construction. Two examples are shown in Figure 3.**

STEP 2 - GAS LINE

Install the gas line piping up to the right side of the appliance. A separate shut-off gas valve (supplied) should always be used. See Figure 4. The manual shut-off valve may be attached to the gas valve instead of the gas supply line if preferred.

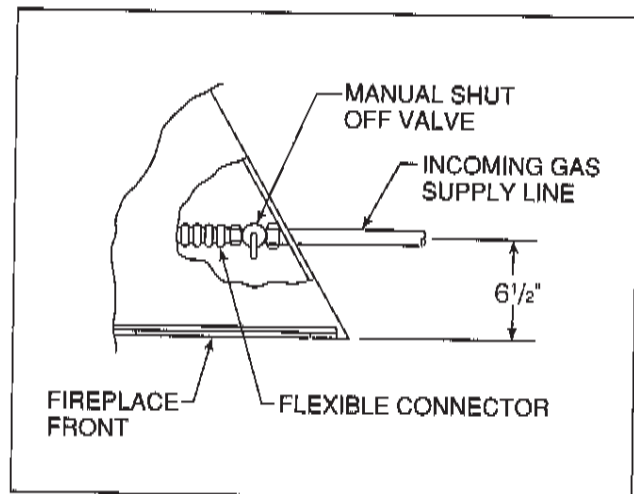

Figure 4

STEP 3 - VENTING CLEARANCES & POSITIONING

Above the back of the cavity a 10" wide x 12" high hole must be cut and framed in where the venting will be terminated. For example, if you are venting directly off of the top of the appliance, center your hole 36 1/4" from the floor. (See Figure 5, page 4.) Add 1/4" for every 2' of run. Every additional vertical VK4 will add 24" to this height. If the wall is non-combustible, such as masonry block or concrete, a 9" diameter round is acceptable. Minimum combustible clearance to the vent on a horizontal run is 3" top, 1" bottom and sides; on a vertical rise, clearances are 1" to sides.

NOTE: The horizontal run of vent must be level or have a 1/4" rise in 2 ft. of run towards the termination. Never allow the vent to run down. This will cause high temperatures and may present the possibility of a fire hazard.

The 10" x 12" hole must be located so the pipe will run level and also perpendicular to the wall. The height of the hole must be situated to meet all local and national codes and not be easily blocked or obstructed. The termination cannot be within 9" of an opening (window/door) into the living area and must be 12" or more above ground level. This venting system is not designed to pass through a floor without proper firestopping (see local codes). After selecting the termination height, follow Table 1 (page 4) to determine the proper length to cut the vent section. (Also see Figure 5, page 4) In Canada, refer to current CAN/CGA-B149.1 and B149.2 for venting codes.

STEP 4 - POSITION

Slide the unit into position and secure in place.

STEP 5 - VENT FROM UNIT

Mount the elbow or vertical pipe section (depending upon your installation) to the top of the appliance by slipping the section into the vent opening on the top of the unit. Secure with (3) screws (supplied). Use only pipe supplied with the appliance and the appropriate number of VK4 sections. **MAINTAIN MINIMUM CLEARANCES OR GREATER.** Do not pack air spaces with insulation or other material.

STEP 6 - SECURING VENT SECTIONS

Each pipe section must be secured in position with a minimum of 1 1/4" overlap and (3) screws (supplied) per joint. VK4 is the only pipe section to be used with this appliance.

STEP 7 - VENTING THROUGH THE WALL

The last section of vent may require cutting, depending on the wall thickness and appliance location. The end of the vent must penetrate the exterior wall. Cut the inner and outer sections so the pipe extends past the wall by 1" on the outer pipe and 2 1/2" on the inner pipe. See Figure 7 (page 5) and Table 2. Horizontal runs will require the use of (1) Vent Support (VS4) for every 3' of vent. The VS4 may be located anywhere along the VK4.

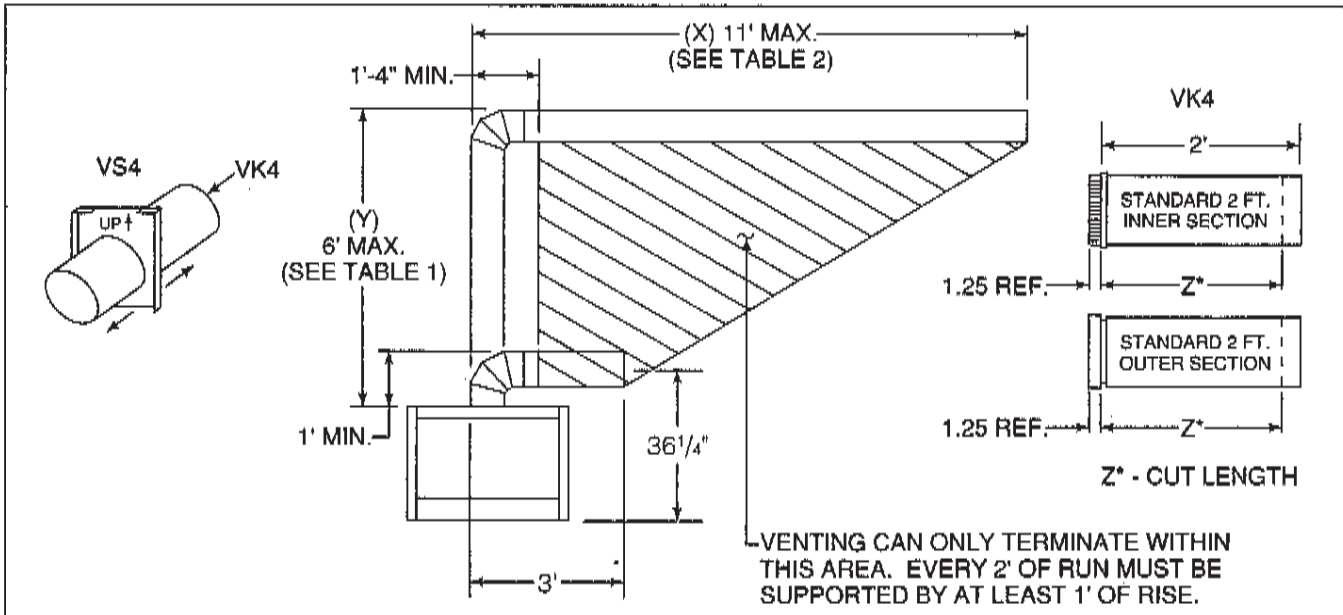

Figure 5

Table 1

(Y) VERTICAL RISE FROM APPLIANCE TOP	NO. OF OPTIONAL VK4's REQUIRED	LENGTH TO CUT TOP SECTION
1'	0	N/A
2'	0	12"
3'	0	No Cutting
4'	1	12"
5'	1	No Cutting
6'	2	12"

NOTE: Every 1' of vertical rise will allow for up to 2' of horizontal run.

Table 2

(X) HORIZONTAL RUN TO TERMINATION (1" BEYOND EXTERIOR WALL)	NO. OF VK4's REQUIRED	(Z) LENGTH TO CUT LAST SECTION	NO. OF VS4's REQUIRED
1' 4"	1	4"	0
3'	1	No Cutting	0
5'	2	No Cutting	1
7'	3	No Cutting	2
9'	4	No Cutting	2
10'	5	12"	3
11'	5	No Cutting	3

NOTE: Every 3' of run will require the use of (1) Vent Support (VS4). Every 2' of run requires at least 1' of rise.

STEP 8 - INTERIOR WALL SHIELD

Place the interior wall shield into position and secure with (4) 1" fasteners, (1) in each corner. Bend the tab and use a 1/2" screw to secure the pipe to the wall shield. See Figure 6. Wall thickness must be 4" minimum to 23 1/2" maximum.

STEP 9 - TERMINATION CAP

To install the cap, slide the cap pipe sections into the vent pipe. Secure the cap flush to the wall using (8) 1" fasteners provided. Seal the cap to the wall with a mastic such as silicone caulking. Fasten the inner vent with (3) 1/2" screws to secure the vent. (An optional CS200 Cap Shield is required if the cap is located in an area of easy accessibility.) See Figure 7. Vent termination must not be recessed into wall or siding.

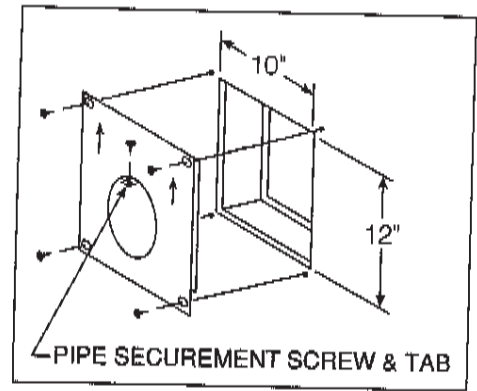

Figure 6
Interior Wall Shield

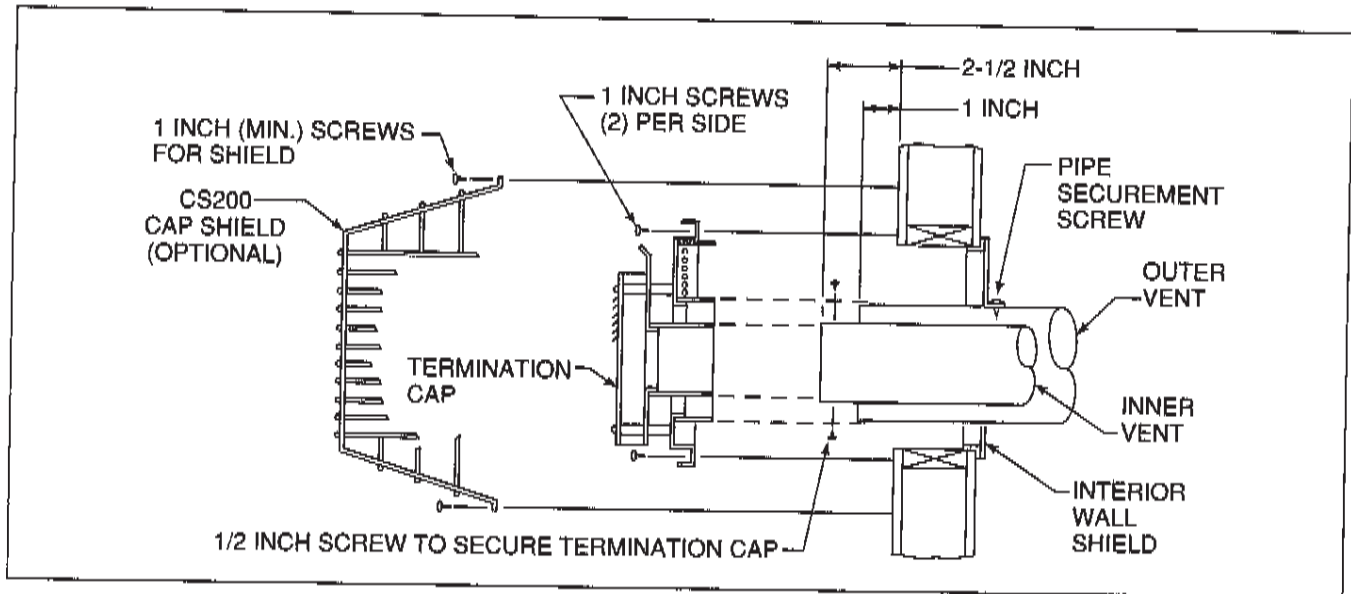

Figure 7
Termination Cap

Figure 8 shows termination cap location minimum dimensions, or follow ANSI Z223.1-latest edition or, in Canada, CAN/CGA-B149.1 and B149.2 installation codes. See page 6 for dimension descriptions.

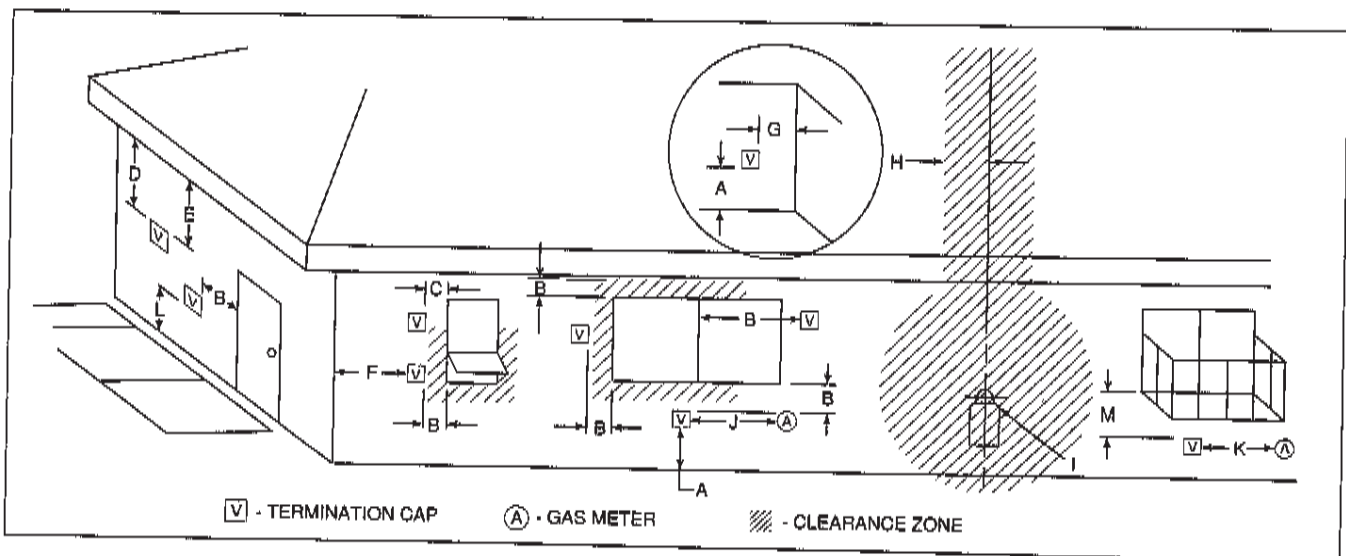

Figure 8
Termination Cap Locations

DIMENSION DESCRIPTIONS FOR FIGURE 8, PAGE 5

- A = Clearance above grade, veranda, porch, deck, or balcony - 12 inches (30 cm) minimum.
 - B = Clearance to window or door that may be opened - 12 inches (30 cm) minimum.
 - C = Clearance to permanently closed window - minimum 12 inches (30 cm) recommended to prevent condensation on window.
 - D* = Vertical clearance to ventilated soffit located above the terminal within a horizontal distance of 2 feet (60 cm) from the center-line of the terminal - 18 inches (46 cm) minimum.
 - E* = Clearance to unventilated soffit - 12 inches (30 cm) minimum.
 - F = Clearance to outside corner - 9 inches as tested.
 - G = Clearance to inside corner - 9 inches as tested.
 - H* = Not to be installed above a meter/regulator assembly within 3 feet (90 cm) horizontally from the center-line of the regulator.
 - I = Clearance to service regulator vent outlet - 6 feet (1.8 m) minimum.
 - J = Clearance to non-mechanical air supply inlet to building or the combustion air inlet to any other appliance - 12 inches (30 cm) minimum.
 - K* = Clearance to mechanical air supply inlet - 6 feet (1.8 m) minimum.
 - L+ = Clearance above paved sidewalk or paved driveway located on public property - 7 feet (2.1 m) minimum.
 - M# = Clearance under veranda, porch deck, or balcony - 12 inches (30 cm) minimum.
- + A vent shall not terminate directly above a sidewalk or paved driveway which is located between two single family dwellings and serves both dwellings.
 - # Only permitted if veranda, porch deck, or balcony is fully open on a minimum of 2 sides beneath the floor.
 - As specified in Installation Codes. Note: Local codes or regulations may require different clearances.
 - * Increased distance required for vinyl soffit materials.

 STEP 10 - GAS LINE CONNECTION

Connect the gas line to the appliance manual valve inlet, using 1/2" pipe. To ease in installation, a listed flexible connector and manual shut-off valve are supplied. The manual shut-off valve may be connected either directly to the gas line or to the gas valve. Gas connections can be made from outside of the appliance by removing the access panel on the right side. (See Figure 1) All connections must be checked for leaks with a soap and water solution.

NOTE: During any pressure testing of the gas supply piping system that exceeds test pressures of 1/2 psig, this appliance and its individual shut-off valve must be disconnected from the piping system. If test pressures equal to or less than 1/2 psig are used in pressure testing the gas supply piping system, this appliance must be isolated from the piping system by closing its individual manual shut-off valve during the testing.

 STEP 11 - WIRING**A. ELECTRONIC IGNITION (CGC100E)**

Remote wall switch hook-up should be installed in a convenient location. Follow Figure 9A for wiring diagram. These models require a 110V power supply. If an optional FK4 Fan Kit or RC5 Remote Control Kit are to be used, wiring should also be done at this time. The appliance must be electrically wired and grounded in accordance with local codes or, in the absence of local codes, with National Electric Code ANSI/NFPA 70-latest edition or, in Canada, the current CSA C22.1 Canadian Electrical Code. Wiring diagrams are provided with these accessories and in Figure 9A. This appliance is not intended for use with a thermostat.

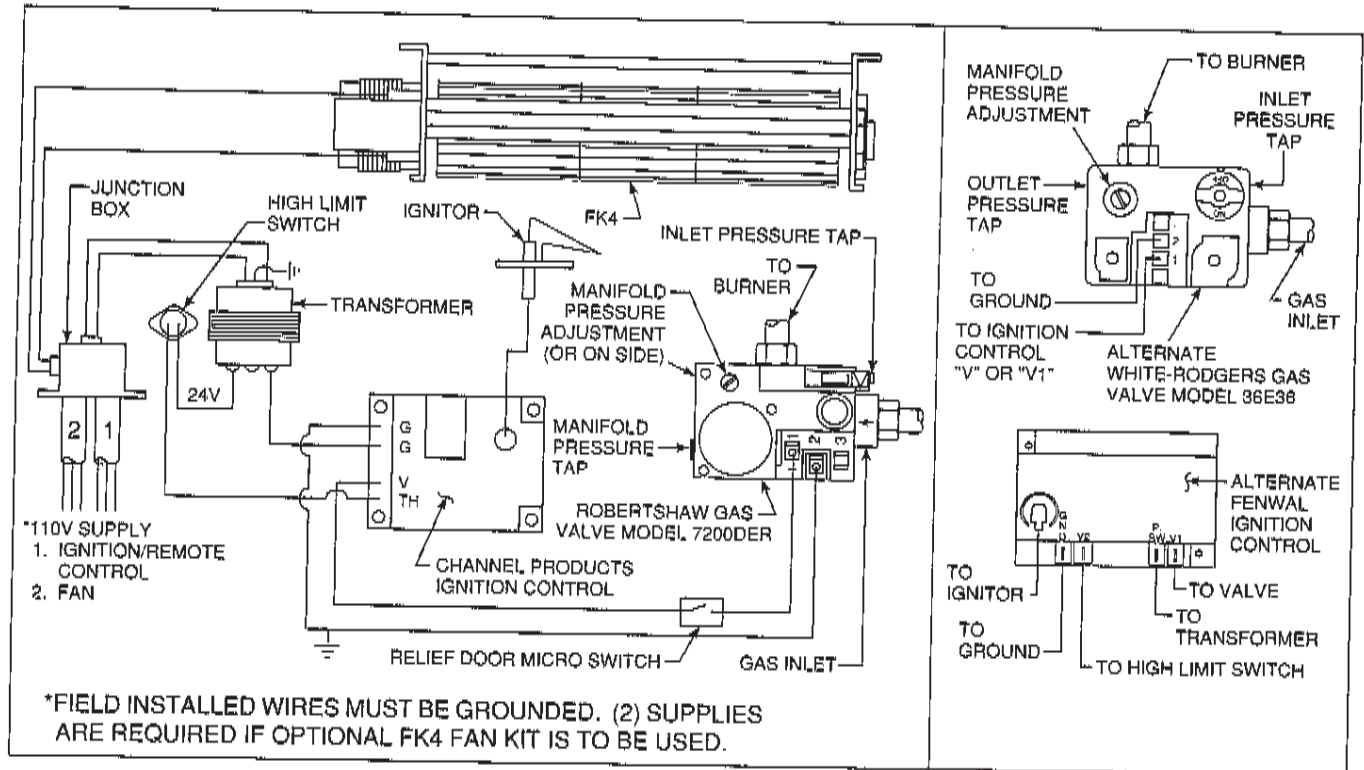

Figure 9A
Electronic Ignition Wiring Diagram

B. STANDING PILOT IGNITION (CGC100, CGC100L)

Remote wall switch hook-up should be installed in a convenient location. Follow Figure 9B for wiring diagram. If an optional FK4 Fan Kit or RC4 Remote Control Kit are to be used, 110 V wiring should be done at this time. (Note: 110V power is not required for ignition.) The appliance must be electrically wired and grounded in accordance with local codes or, in the absence of local codes, with National Electric Code ANSI/NFPA 70-latest edition. Wiring diagrams are provided with these accessories and in Figure 9B. This appliance is not intended for use with a thermostat.

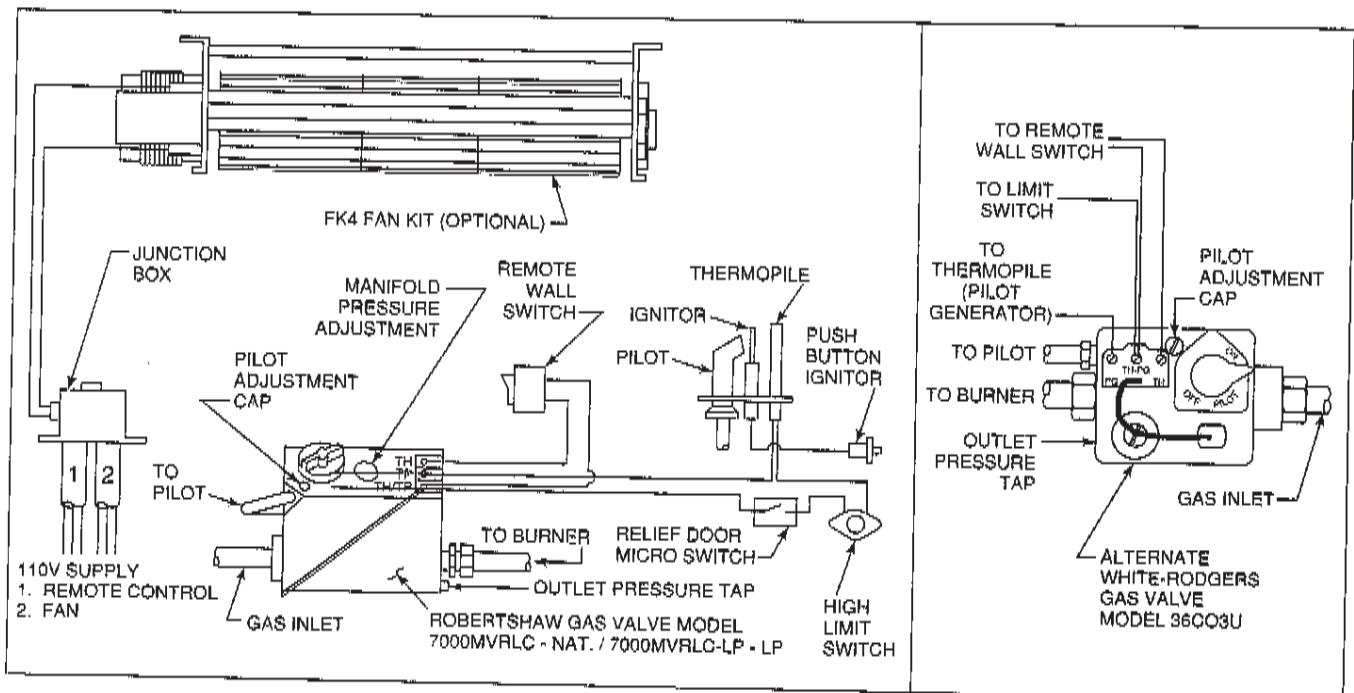

Figure 9B
Standing Pilot Ignition Wiring Diagram

□ STEP 12 - FINISHING

Attach the hood (supplied with the appliance) where shown in Figure 1. When finishing the face of the unit, combustible material may be brought up to the sides of the unit, but must never overlap onto the black metal. The black metal may be covered with non-combustible material only. **NOTE: You cannot cover any of the air slots in the unit, as this may create a fire hazard.** See Figure 1 for air slot location. A combustible mantel may be installed at a minimum of 42 inches above the base of the unit.

Position the hood in place as shown in Figure 10. Secure with the (3) screws supplied.

Install the screen panel using the screws provided.

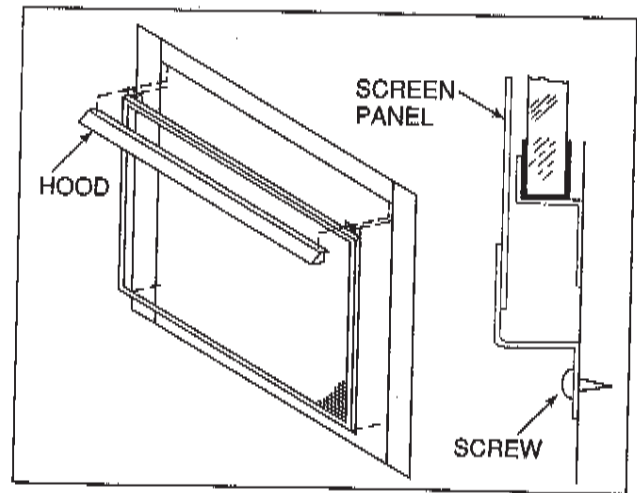

Figure 10

V. OPERATING INSTRUCTIONS

A. Before operating this appliance, proceed through the following check list:

1. Verify log, rock wool and vermiculite placement. They are shipped in a separate box and must be positioned as shown in Figure 11. Do not cover the slot in front of burner tube with vermiculite or you will adversely affect flame appearance.

2. Check to see that all wiring is correct and enclosed to prevent possible shock.

3. Check to ensure there are no gas leaks, using a soap and water solution.

4. Make sure front glass is sealed and in its proper position. Never operate the appliance with the front glass removed or not sealed.

5. Ensure the screen panel is in position as shown in Figure 10.

6. Verify all venting and cap are unobstructed. Exhaust gases are extremely hot. Make sure there are no possible future obstructions from trees/bushes, snow drifts, etc. A Cap Shield (CS200) can be purchased to help prevent possible contact.

7. Read and understand these Instructions before operating this appliance.

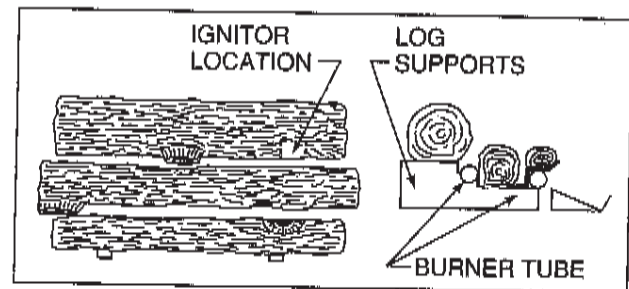

Figure 11

B. ELECTRONIC IGNITION (CGC100E)

1. LIGHTING PROCEDURE

Steps a. - d. are to be followed for initial start-up and seasonal start-up. Step e. is sufficient for later starts in-season.

- a. Turn the remote wall switch to the "Off" position.
 - b.1. Push gas control lever in and slide the lever to the "Off" position (Robertshaw).
 2. Rotate gas control knob to the "Off" position (White-Rodgers).
- c. Wait five minutes to allow gas, that may have accumulated in the main burner compartment, to escape.
- d. Move the gas control to the "On" position.
- e. Turn wall switch to the "On" position. This will turn on the ignitor and light the main burner.

2. SHUTDOWN PROCEDURE

- a. To shut off the main burner, move the wall switch to the "Off" position.
- b. To shut off the entire system:
 1. Push gas control lever in and slide the lever to the "Off" position (Robertshaw).
 2. Rotate gas control knob to the "Off" position (White-Rodgers).

C. STANDING PILOT IGNITION (CGC100, CGC100L)

1. LIGHTING PROCEDURE

Steps a. - e. are to be followed for initial start-up and seasonal start-up. Step f. is sufficient for later starts in-season.

- a. Turn the remote wall switch to the "Off" position.

- b. Push in and turn the gas control knob to the "Off" position. Wait (5) minutes to allow gas, that may have accumulated in the main burner compartment, to escape.
- c. Turn the gas control knob to "Pilot".
- d. Push and hold the gas control knob all the way in. Immediately light the pilot by pressing the red ignitor button. Continue to hold the gas knob in for about (1) minute after the pilot is lit. Release the knob and it will pop back up. The pilot should remain lit. If it goes out, repeat steps a. through d.
- e. Turn the gas control knob to the "On" position.
- f. Turn the wall switch to the "On" position. This will turn on the main burner.

2. SHUTDOWN PROCEDURE

For temporary situations, the main burner may be kept from operating by turning the gas control knob to "Pilot". The pilot burner will then remain lit, ready for return to normal service. For longer periods of shut-off, push the gas control knob down and turn to "Off". This will shut off both the pilot and main burner.

Keep the burner and control compartment clean. Due to high surface temperatures, keep children, clothing and furniture away.

3. PILOT BURNER ADJUSTMENT (Preset at factory)

Under certain circumstances the size of the pilot may have to be adjusted. It is accomplished as follows:

- a. Remove the pilot adjustment cap. See Figure 9B.
- b. Adjust the pilot key to provide properly sized flame. (See Figure 12B for proper flame appearance.)
- c. Replace the pilot adjustment cap.

VI. MAINTENANCE INSTRUCTIONS

CAUTION

IN THE EVENT THE RELIEF DOOR MICRO SWITCH HAS BEEN ACTIVATED, CONTACT YOUR GAS APPLIANCE DEALER IMMEDIATELY, OR CONTACT HEATILATOR CUSTOMER SERVICE. DO NOT ATTEMPT TO OVERRIDE OR REPAIR THE SAFETY SYSTEM.

- A. Keep the burner and control compartment clean by brushing and vacuuming at least once a year. Always turn off the valve before cleaning.
- B. Visually check the flame of the burner periodically, making sure the flames are steady; not lifting or floating. The flame color should be blue with yellow tips. The ignitor (electronic) or thermopile (standing pilot) tips should be covered with flame. See Figures 12A or B and 13.
- C. The appliance and venting system should be inspected before use, and at least annually, by a qualified field service person, to ensure that the flow of combustion and ventilation air is not obstructed.

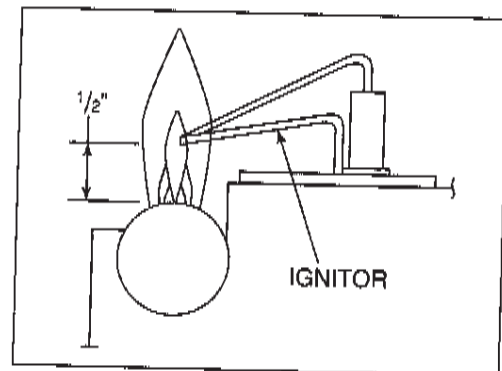

Figure 12A
(CGC100E)

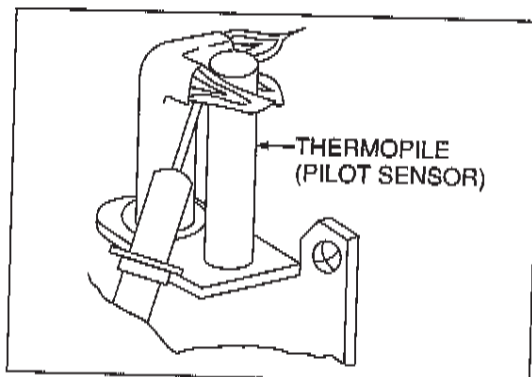

Figure 12B
(CGC100, CGC100L)

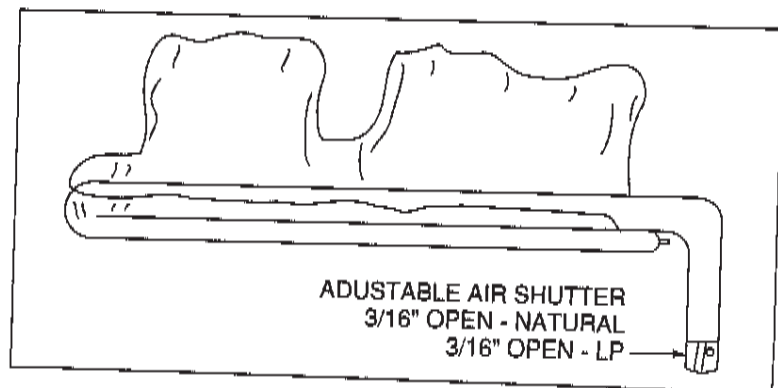

Figure 13

- D. Keep the area near the appliance clear and free from combustible materials, gasoline and other flammable vapors and liquids.
- E. **When first operated, the unit will release an odor for about an hour. This is caused by the curing of the paint and the burning off of any oils remaining from manufacturing. The glass panel will require removal and cleaning after the unit has cooled down. DO NOT ATTEMPT TO REMOVE THE GLASS WHILE IT IS HOT.**

WARNING

CHILDREN AND ADULTS SHOULD BE ALERTED TO THE HAZARDS OF HIGH SURFACE TEMPERATURE AND SHOULD STAY AWAY TO AVOID BURNS OR CLOTHING IGNITION. YOUNG CHILDREN SHOULD BE CAREFULLY SUPERVISED WHEN THEY ARE IN THE SAME ROOM AS THE APPLIANCE.

CAUTION

ANY SAFETY SCREEN OR GUARD REMOVED FOR SERVICING AN APPLIANCE MUST BE REPLACED PRIOR TO OPERATING THE APPLIANCE.

CLOTHING OR OTHER FLAMMABLE MATERIAL SHOULD NOT BE PLACED ON OR NEAR THE APPLIANCE.

- F. **Each time the appliance is lit, it may cause condensation and fog the glass. This condensation and fog will disappear in a few minutes.**
- G. **GLASS CLEANING.**

It is recommended to wear gloves while handling or removing glass.

To remove glass for cleaning of burner area - **(DO NOT REMOVE WHEN HOT):**

1. Remove the bottom panel by lifting it and then pulling it free of the appliance.
2. Remove the screen panel (see Figure 10, page 8), revealing the glass mounting strip.
3. Hold the glass to ensure it doesn't fall and remove the (5) bolts in the glass support channel at the top of the glass.
4. Remove the top channel, tilt the glass out and lift it out of the bottom channel.

NOTE: NEVER use abrasive materials to clean glass. NEVER clean glass when HOT.

To replace glass, reverse the process.

CAUTION: Handle glass assembly with care to avoid striking or scratching of glass on hard objects.

Never operate the appliance without glass properly secured in place or if glass is broken.

In the event of glass breakage, follow glass removal instructions above to remove the top retaining strip. Remove lower retaining strip in the same manner. This will allow the removal of all glass fragments and sheet metal edge protection strips. Vacuum all remaining glass pieces with a shop vac. **(DO NOT VACUUM IF PIECES ARE HOT.)** Replace glass only with Heatilator assembly number 17536 replacement parts ordered direct or through your local distributor. Never use substitute material. Only 3/16" x 33 3/4" x 18" ceramic glass panel may be used on this appliance.

H. **LOG REPLACEMENT AND CLEANING.**

After removing glass, logs can be lifted out of position. If for any reason one should need replacement, you must use the proper replacement log. The position of these logs must be as shown in the diagram under Replacement Parts. **NOTE: Improper positioning of logs may create carbon build-up and will alter the unit's performance.**

Carbon build-up can be removed with a vacuum cleaner.

TROUBLE SHOOTING - STANDING PILOT (CGC100, CGC100L)

<u>Problem</u>	<u>Cause</u>	<u>Corrective Action</u>
1. Spark ignitor will not light the pilot after repeat pressing of Red Button.	A. Defective ignitor. B. Misaligned electrode at pilot.	Check for loose connections on electrode and ignitor. Check for spark. If electrode connection is correct and no spark, replace ignitor. Spark should be extending approx. 1/8" to pilot hood. Adjust gap to give proper spark. Remove hands from electrode before pressing Red Button.
2. Pilot light will not stay lit.	A. Defective pilot thermopile.	Check pilot flame. See Fig. 11B. Adjust flame if necessary. Be sure thermopile is secured tight into pilot bracket. Be sure wiring connections are tight throughout system, including high limit switch. Check thermopile voltage with millivolt meter. Depress valve knob and light pilot. Meter should read min. of 325 millivolt. If not, replace the thermopile.
3. With pilot lit, valve and on/off switch in "On" position, no gas to burner.	A. On/off switch defective. B. Plugged burner orifice.	Check on/off switch for proper connections. Connect wires across terminal at on/off switch. If burner comes on, replace on/off switch. If burner does not come on, connect to on/off switch junctions at valve. If burner comes on, replace wires. Check burner orifice; remove blockage.
4. Appliance turns itself off after a period of time.	A. High limit safety switch is activated.	Have a qualified service technician check venting system for blockage, e.g., bird nests, damage. Ensure proper venting condition and reset limit switch located on draft hood. To reset limit switch, insert a long narrow object such as a pencil through the hole provided, and press in the button on the back of the limit switch.
5. Glass Fogs up.	A. A normal result of gas combustion.	No action is necessary. After the appliance has warmed up, the glass will clear.

ELECTRONIC IGNITION (CGC100E)**FOR YOUR SAFETY READ BEFORE LIGHTING**

WARNING: If you do not follow these instructions exactly, a fire or explosion may result causing property damage, personal injury or loss of life.

- A. This appliance does not have a pilot. It is equipped with an ignition device which automatically lights the burner. Do not try to light the burner by hand.
- B. **BEFORE OPERATING** smell all around the appliance area for gas. Be sure to smell next to the floor because some gas is heavier than air and will settle on the floor.

WHAT TO DO IF YOU SMELL GAS

- Do not try to light any appliance.
 - Do not touch any electric switch; do not use any phone in your building.
 - Immediately call your gas supplier from a neighbor's phone. Follow the supplier's instructions.
 - If you cannot reach your gas supplier, call the fire department.
- C. Use only your hand to push in and move the gas control lever, or rotate the gas control knob. Never use tools. If the lever will not push in or move by hand, don't try to repair it; call a qualified service technician. Force or attempted repair may result in a fire or explosion.
- D. Do not use this appliance if any part has been under water. Immediately call a qualified service technician to inspect the appliance and to replace any part of the control system and any gas control which has been under water.

OPERATING INSTRUCTIONS

1. STOP! Read the safety information above on this label.
2. Turn wall switch to the "OFF" position.
3. Turn off all electric power to the appliance.
4. This appliance is equipped with an ignition device which automatically lights the burner. Do not try to light burner by hand.
- 5a. Push gas control lever in and move to the "OFF" position (Robertshaw).
- b. Rotate gas control knob to the "OFF" position (White-Rodgers).
6. Wait five (5) minutes to clear out any gas. If you then smell gas, STOP! Follow "B" in the safety information above on this label. If you don't smell gas, go to the next step.
7. Move gas control to the "ON" position.
8. Replace control access panel.
9. To turn on burner, turn on all electric power to this appliance.
10. If the appliance will not operate, follow the Instructions "TO TURN OFF GAS TO APPLIANCE" and call your service technician or gas supplier.

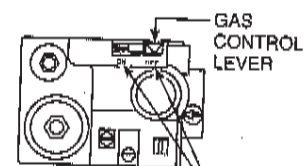

POSITION INDICATOR
ROBERTSHAW

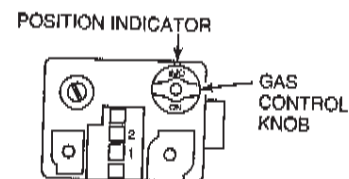

POSITION INDICATOR
WHITE-RODGERS

TO TURN OFF GAS TO APPLIANCE

1. Turn off the wall switch.
2. Turn off all electric power to the appliance if service is to be performed.
3. Push gas control lever in and move to the "OFF" position. Do not force.
4. Replace control access panel.

Due to high surface temperatures, keep children, clothing and furniture away. Keep burner and control compartment clean. See Installation and Operating Instructions accompanying the appliance.

STANDING PILOT (CGC100, CGC100L)**FOR YOUR SAFETY READ BEFORE LIGHTING**

WARNING: If you do not follow these instructions exactly, a fire or explosion may result causing property damage, personal injury or loss of life.

- A. This appliance has a pilot which must be lighted by hand. When lighting the pilot, follow these instructions exactly.
- B. BEFORE LIGHTING smell all around the appliance area for gas. Be sure to smell next to the floor because some gas is heavier than air and will settle on the floor.
- WHAT TO DO IF YOU SMELL GAS
- Do not try to light any appliance.
 - Do not touch any electric switch; do not use any phone in your building.
 - Immediately call your gas supplier from a neighbor's phone. Follow the supplier's instructions.
- C. Use only your hand to push in or turn knob. Never use tools. If the knob will not push in or turn by hand, don't try to repair it; call a qualified service technician. Force or attempted repair may result in a fire or explosion
- D. Do not use this appliance if any part has been under water. Immediately call a qualified service technician to inspect the appliance and to replace any part of the control system and any gas control which has been under water.
- If you cannot reach your gas supplier, call the fire department.

LIGHTING INSTRUCTIONS

1. STOP! Read the safety information above on this label.
2. Turn on/off switch to the "OFF" position.
3. Turn off all electric power to the appliance.
4. Remove control access panel.
5. Push in and turn gas control knob clockwise to "OFF".

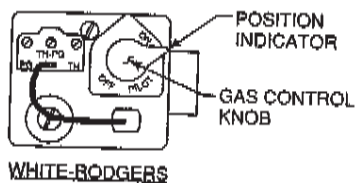
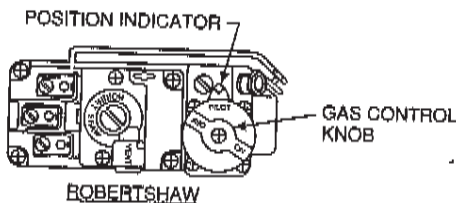

6. Wait five (5) minutes to clear out any gas. If you then smell gas, STOP! Follow "B" in the safety information above on this label. If you don't smell gas, go to next step.

7. Find pilot - follow metal tube from gas control. The pilot is behind the burner tube.



8. Turn knob on control counterclockwise to "PILOT".
9. Push in the knob all the way and hold in. Immediately light the pilot by pressing the red ignitor button. Continue to hold the control knob in for about (1) minute after the pilot is lit. Release button and it will pop back up. Pilot should remain lit. If it goes out, repeat steps 5 through 9.
 - If button does not pop up when released, stop and immediately call your service technician or gas supplier.
 - If the pilot will not stay lit after several tries, turn the gas control knob to "OFF" and call your service technician or gas supplier.
10. Turn gas control knob counterclockwise to "ON". Knob can be turned to "ON" only if the control knob is popped out.
11. Replace control access panel.
12. Turn on all electric power to the appliance.

TO TURN OFF GAS TO APPLIANCE

1. Turn off the on/off switch.
2. Turn off all electric power to the appliance if service is to be performed.
3. Remove control access panel.
4. Turn gas control clockwise to "OFF". Do not force.
5. Replace control access panel.

Attention

APPLIANCE INSTALLER

*Please return these
Operating & Installation
Instructions to the
Appliance
for Consumer Use*

heatilator®
The first name in fireplaces

Heatilator Inc.
1915 W. Saunders Street
Mt. Pleasant, IA 52641
a HON INDUSTRIES company
319/385-9211 FAX 319/385-9225