

Installation & Operating Manual

SF1500A, SF2500A, SF2600A, SF3500A Hot Air Furnaces

Some models listed have been retired.
Service parts list has been removed from this manual for
all models listed. An updated manual has been created
for current models.
For retired models, refer to individual service parts lists.

HARMAN®

BUILT TO A STANDARD, NOT A PRICE

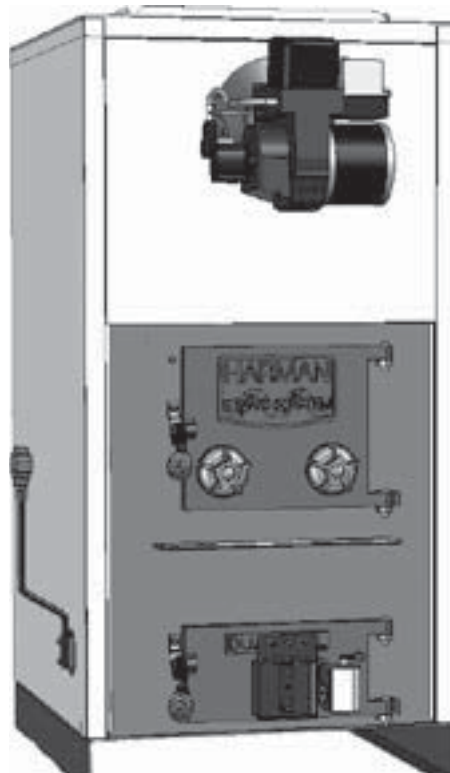

We suggest that our
hearth products be
installed and serviced by
professionals who are
certified in the U.S. by
the National Fireplace
Institute (NFI) as NFI
Specialists.



“Ce manuel est disponible en Français sur demande”

SAFETY NOTICE

PLEASE READ THIS ENTIRE MANUAL BEFORE YOU INSTALL AND USE YOUR HEATING APPLIANCE. FAILURE TO FOLLOW INSTRUCTIONS MAY RESULT IN PROPERTY DAMAGE, BODILY INJURY, OR EVEN DEATH.

FOR USE IN THE U.S. AND CANADA. NOT SUITABLE FOR INSTALLATION IN MOBILE HOMES

IF THIS FURNACE IS NOT PROPERLY INSTALLED, A HOUSE FIRE MAY RESULT. FOR YOUR SAFETY, FOLLOW INSTALLATION DIRECTIONS.

CONTACT LOCAL BUILDING OR FIRE OFFICIALS ABOUT RESTRICTIONS AND INSTALLATION INSPECTION REQUIREMENTS IN YOUR AREA.

CONTACT YOUR LOCAL AUTHORITY (SUCH AS MUNICIPAL BUILDING DEPARTMENT, FIRE DEPARTMENT, FIRE PREVENTION BUREAU, ETC.) TO DETERMINE THE NEED FOR A PERMIT.

THIS APPLIANCE IS ALSO APPROVED FOR INSTALLATION INTO A SHOP.

SAVE THESE INSTRUCTIONS.

Table of Contents

Harman® Central Heating Appliances are built and tested to be complete Home Heating solutions. As with any Central Heat system, a backup heating system may be required in the event of power outages or during appliance service or maintenance.

Packing List	3
Installation	5
Mounting Blower & Filter Box	7
Wiring	8
Duct Work	11
Operation	11
Safety Tips	13
Chimney Troubleshooting	13
Maintenance	14
Specifications	15
Coil Installation	16
Oil Burner Setup	18
Service Parts	19
Warranty	27

→ = Contains updated information

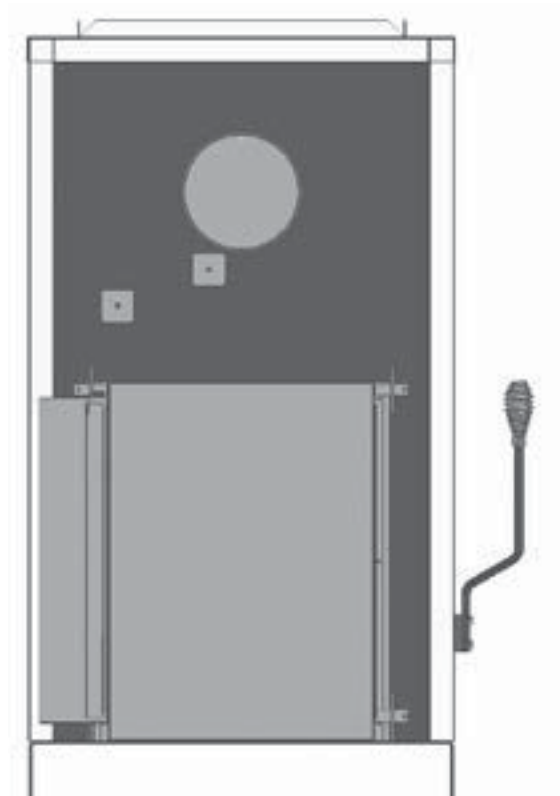
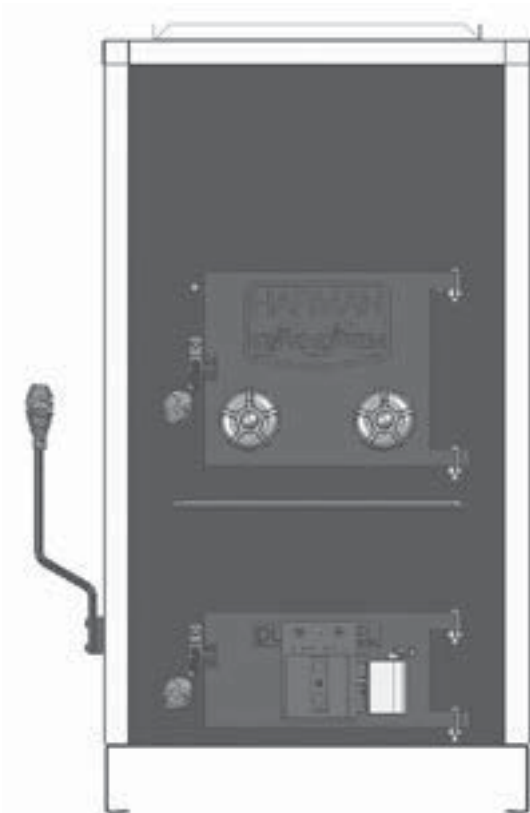

Packing List - SF2600

Blue Angel Oil Burner- (Sold Separately)

Burner Gasket

Automatic Draft Control

Blower - (Sold Separately)

(2) Blower Brackets - (Included with blower)

Filter Box Kit (3 pieces) + Filter

Fan Control / High Limit

(2) Thermostats

(2) Junction Boxes

Relay

High Limit Snap Disc

(4) 1/4 X 3/4 bolts & (4) Filter Box Mounting Clips

36" Flex Conduit

(1) Straight Conduit Fitting

(1) Elbow Conduit Fitting

Ash Pan

Shaker Handle

Owner's Manual

Warranty Registration

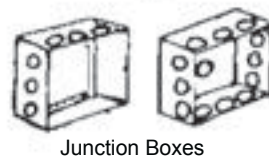
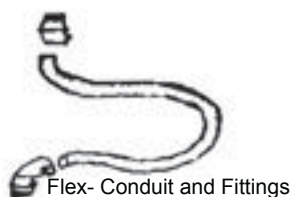
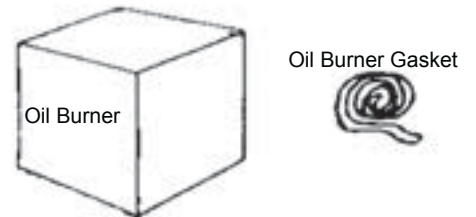
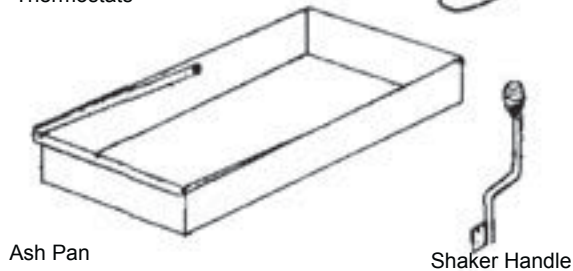
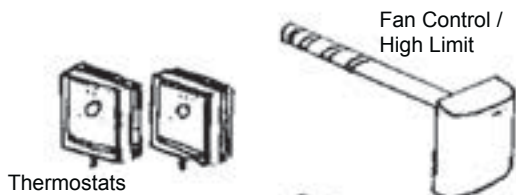
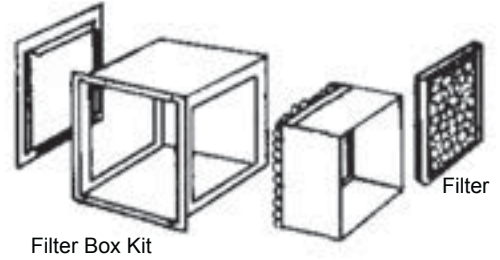

Packing List for SF1500, SF2500 & SF3500

- Blower Mounting Plate w/ 2 5/16X3/4 bolts (SF3500 Only)
- Automatic Draft Control
- Blower - (Sold Separately)
- (2) Blower Brackets - (Included with blower)
- Filter Box Kit (3 pieces) + Filter
- Fan Control / High Limit
- 3-Speed Fan Switch (not on SF3500)
- Thermostat
- Junction Box
- Relay
- (4) 1/4 X 3/4 bolts & (4) Filter Box Mounting Clips
- 36" Flex Conduit
- (1) Straight Conduit Fitting
- (1) Elbow Conduit Fitting
- Ash Pan
- Shaker Handle
- Owner's Manual
- Warranty Registration

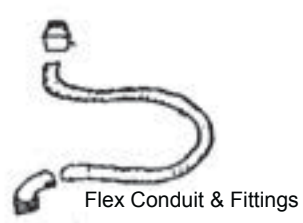
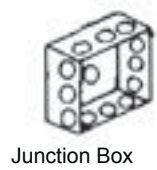
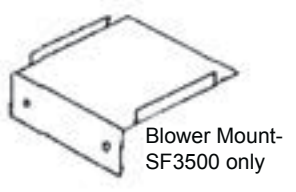
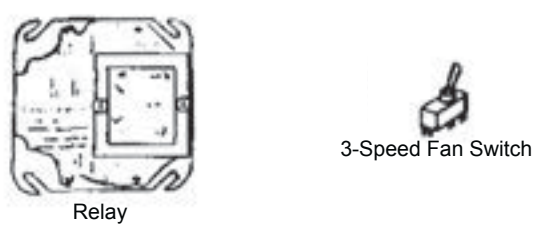
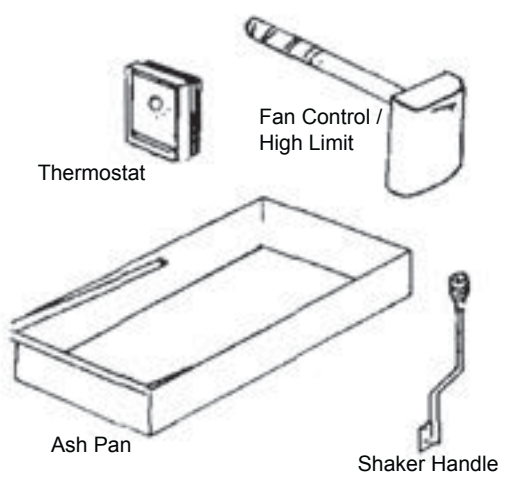
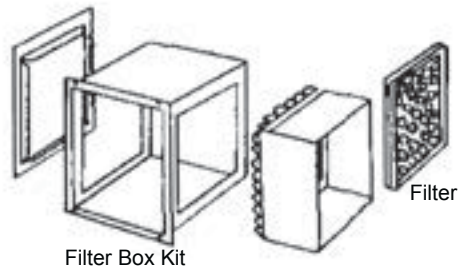

Furnace Installation

To ensure a safe installation, it is recommended that this furnace be installed by a qualified installer.

The sheet metal top and sides can be easily removed to reduce the chance of dents or scratches on the painted surfaces.

To remove the sheet metal, first lift off the top section. Now the sides can be removed by lifting up and out away from the furnace.

To lighten the SF2600, the oil burner heat exchanger should be removed. Do so by first removing the sheet metal as described above. Remove the front sheet metal by first removing the burner collar. Now remove the two long bolts on each side of the heat exchanger (Figure B). The entire unit can now be lifted off and moved separately.

Caution: This furnace must not be installed closer than 24 inches at the sides and 30 inches from the rear to combustible materials. The unit may only be installed on a non-combustible floor surface such as concrete floor or concrete pad on dirt floor. The hot air plenum must be a minimum of 2 inches from the ceiling or other combustibles above the plenum.

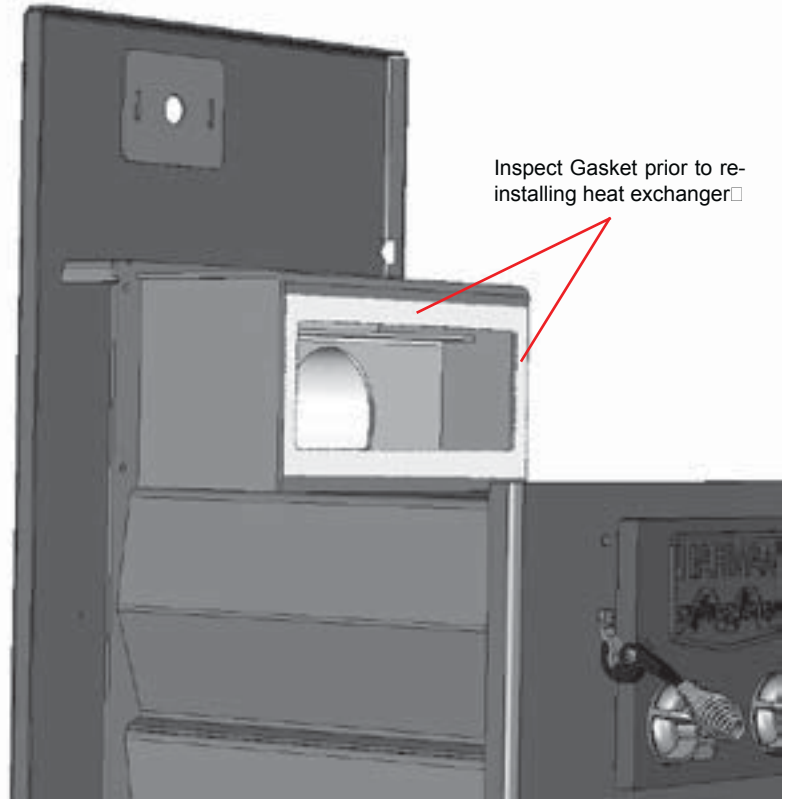

Figure A

Locate the furnace as close to the chimney as possible while still maintaining the above clearances. No more than 4 feet of stove pipe should be used including two or less 90° elbows. All horizontal runs of pipe should have a minimum 1/4 in. rise per foot. All stove pipe must be 24 gauge or thicker.

When re-installing the heat exchanger, inspect the gasket around the furnace opening and replace if necessary (Figure A). Place the heat exchanger in position and secure with the long bolts and nuts. Be sure the gasket is compressed evenly.

Re-install the sheet metal by sliding the groove on the bottom of each side panel over the steel lip on the furnace. The top sheet metal piece holds the sides in place. The SF2600 front cover gets installed by angling the bottom edge over the lip on the top of the firebox. The side edges must slide into the grooves on each side and pushed in flush with the sides and top. This front piece is held in place by the black ring which gets tightened around the burner pipe. Do not over tighten as this will push the sheet metal in too far.

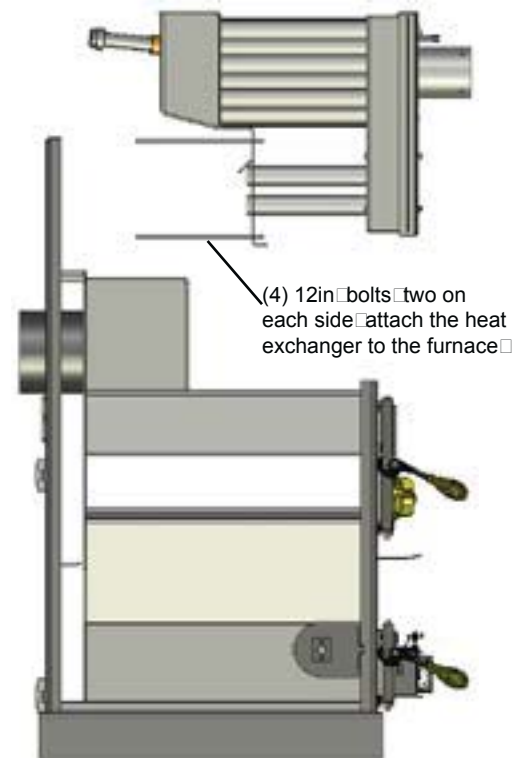

Figure B

Furnace Installation

Installing Wood/Coal High Limit Switch- SF2600 only

First install the sheet metal sides as described in the previous section. Install the snap disc switch into the hole on the right side sheet metal. Then mount the open backed junction box around the snap switch. Proceed with wiring as shown on page 10. Also refer to Figure D in this section.

Mounting The Oil Burner- SF2600 only

Remove the oil burner unit from its box. Loosen the four bolts in the pipe on the front of the furnace. Insert the nose of the oil gun into the pipe. Before sliding the oil burner all the way in, apply the gasket around the nose of the oil gun by wrapping it around the nose. Next, slide the oil burner into the pipe and secure it by tightening the four bolts around the collar. Be sure to tighten the bolts evenly to locate the oil burner in the center of the pipe. The final set-up of the oil burner should be done by an experienced oil burner technician with the proper equipment. Refer to the SF2600 wiring diagram on page 10 and the oil burner manual for proper burner set-up. There is also a section at the end of this manual with specific oil burner instructions.

Venting Guidelines.

Your Harman hot-air furnace must be vented to its own separate flue-lined "Class A" chimney, not less than 8" X 8" in size. The chimney must be capable of providing a draft reading of at least 0.6" water column on a draft meter in order to function properly. The Chimney must be a minimum of 16 ft high and must be two feet higher than anything within 10 ft. The chimney must also be at least 3 ft higher than the point at which it exits or passes by the roof. A barometric damper must be installed in the flue to eliminate excessive draft. Any horizontal sections of connector pipe must have at least 1/4 in per foot rise. Limit the number of elbows to two or less. All joints in the connector pipe must be secured with sheet metal screws.

Assembly.

Bolt the shaker handle to the block on the lower left side of the furnace using the bolts and lock-washers provided.

Bolt the two manual draft controls to the front load door. Proper installation allows the draft controls to open approximately 1/2" from the door surface. See Figure 1.

Bolt the automatic draft control to the bottom door. Be sure to hold the unit straight while tightening. After the automatic draft control is mounted, the two wires must be strung through the flexible conduit and two fittings supplied. The knockout plug of the junction box must be removed to install the conduit fitting. Check the door of the automatic draft control to assure proper operation. **Warning:** Keep pieces of wood or coal out of the draft door opening mechanism as this could cause the door to stick.

NOTE: Oil the hinge at the beginning of the heating season with a light oil.

The junction box is best mounted on the side of the furnace about 1 in back and 1 in from the top of the sheet metal side. (fig. C or D) If this location is inconvenient, anywhere on the right side will work.

SF1500, SF2500, SF3500.

This figure represents the models; SF1500, SF2500, and SF3500. Its intention is to represent the approximate location of the various controls. This drawing may also be used as a recommendation for routing of the wiring and approximate dimension of control spacing.

Please note that this drawing is for reference only. Each specific installation will vary.

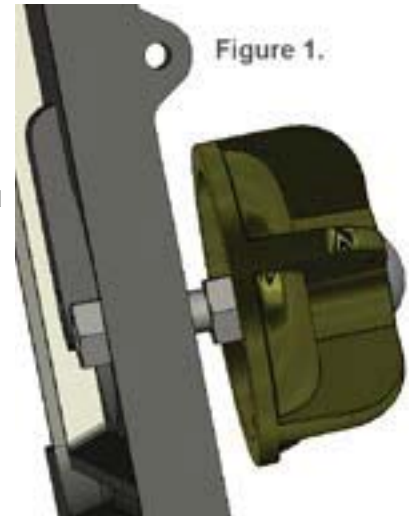

Figure 1.

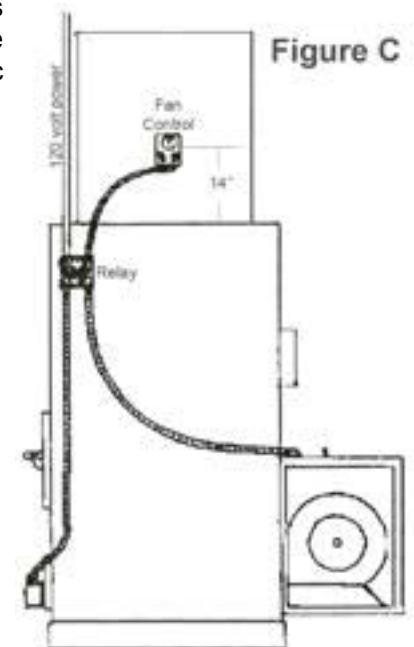
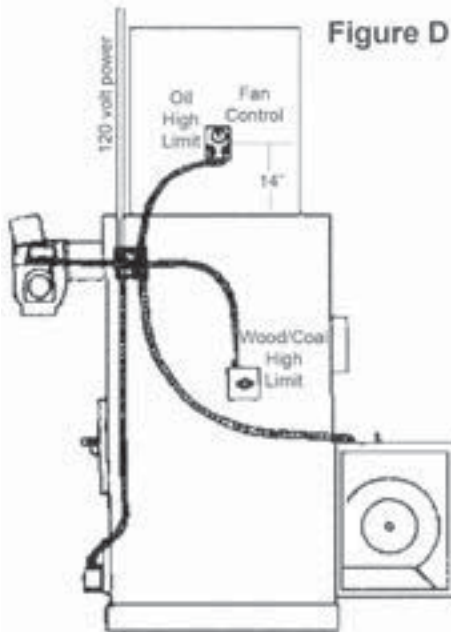

Figure C

Furnace Installation

SF2600.



This figure represents the model SF2600 furnace. It's intention is to represent the approximate location of the various controls. This drawing may also be used as a reference for wiring and control spacing. Please note that this drawing is for reference only. Specific installations will vary.

Mounting The Blower And Filter Box

Position the filter box between the brackets on the rear of the furnace, with the bottom of the box resting on the flange at the bottom of the furnace. Insert the mounting clips into the bracket slots to secure the filter box. (see Figure 2) Next, install the blower brackets onto the blower being sure to install the rubber feet into the brackets. **All hardware, brackets, etc. for the blower, will be found in the carton with the blower.** Next, position the blower in the filter box, centered behind the inlet hole and allow approximately 1/8 in. space between the rear of the furnace and the blower outlet. Now, install the filter rail onto the filter box. NOTE: The filter rail is best installed on the side toward the shaker handle, so that any pipes from the hot water coil do not interfere with filter installation or removal.

NOTE: Before proceeding with the installation of the access door, it is suggested that the wiring be completed.

The access door is installed by slipping the flange on the bottom of the access door over the bottom rail of the filter box opening, then push the top of the door against the top of the filter box opening and secure with a sheet metal screw.

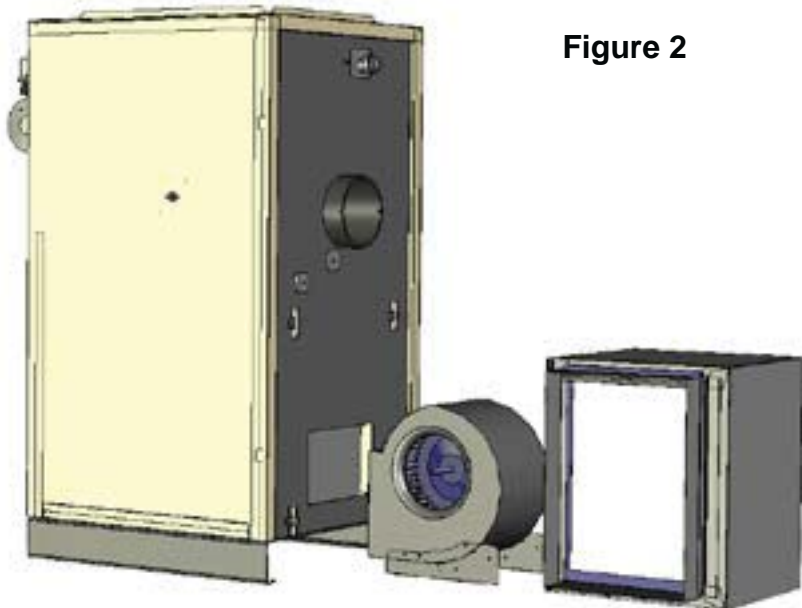
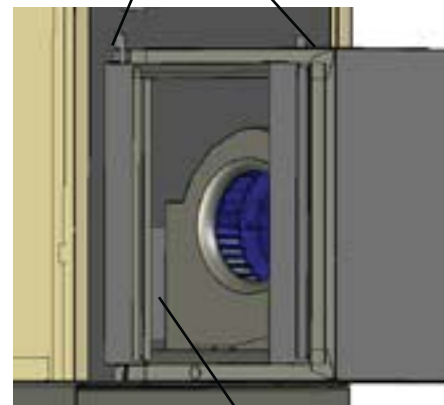

Figure 2

Filter box mounting clips



1/8 in. space between blower and furnace

Furnace Installation - Wiring

Wiring

Before beginning any wiring, study the appropriate wiring diagram for your unit. Also refer back to figures C or D for an example of what the completed job will look like. **It is your responsibility to follow all state and local electrical codes.** Locate the best place to route the power for the blower, and drill a 7/8" hole in the filter box. This hole size will accommodate a "romex" connector. Attach the blower and power wires as shown on the appropriate wiring diagram.

Once you have the plenum installed, the fan control with high limit switch can be installed. The Fan control/high limit switch is packaged with a jumper between the two sets of terminals inside. **REMOVE THE JUMPER WIRE INSIDE THE FAN CONTROL.** The fan control should be installed in the right side of the plenum and 12 to 18 inches above the top of the furnace. A separate conduit should be run from the fan control to the junction box.

Mount the thermostat in a central location of the area you want to heat. Run two wires to the junction box from the heating terminals on the thermostat. 22 gauge or thicker wire is acceptable.

The next step is to run a 120 volt line from your breaker panel to the junction box. Attach all wires according to the corresponding wiring diagram and install the relay into the junction box. **DO NOT TURN OFF THE BREAKER UNTIL ALL WIRING IS COMPLETE AND THE RELAY IS SECURED.**

SF1500 and SF2500 Wiring Diagram

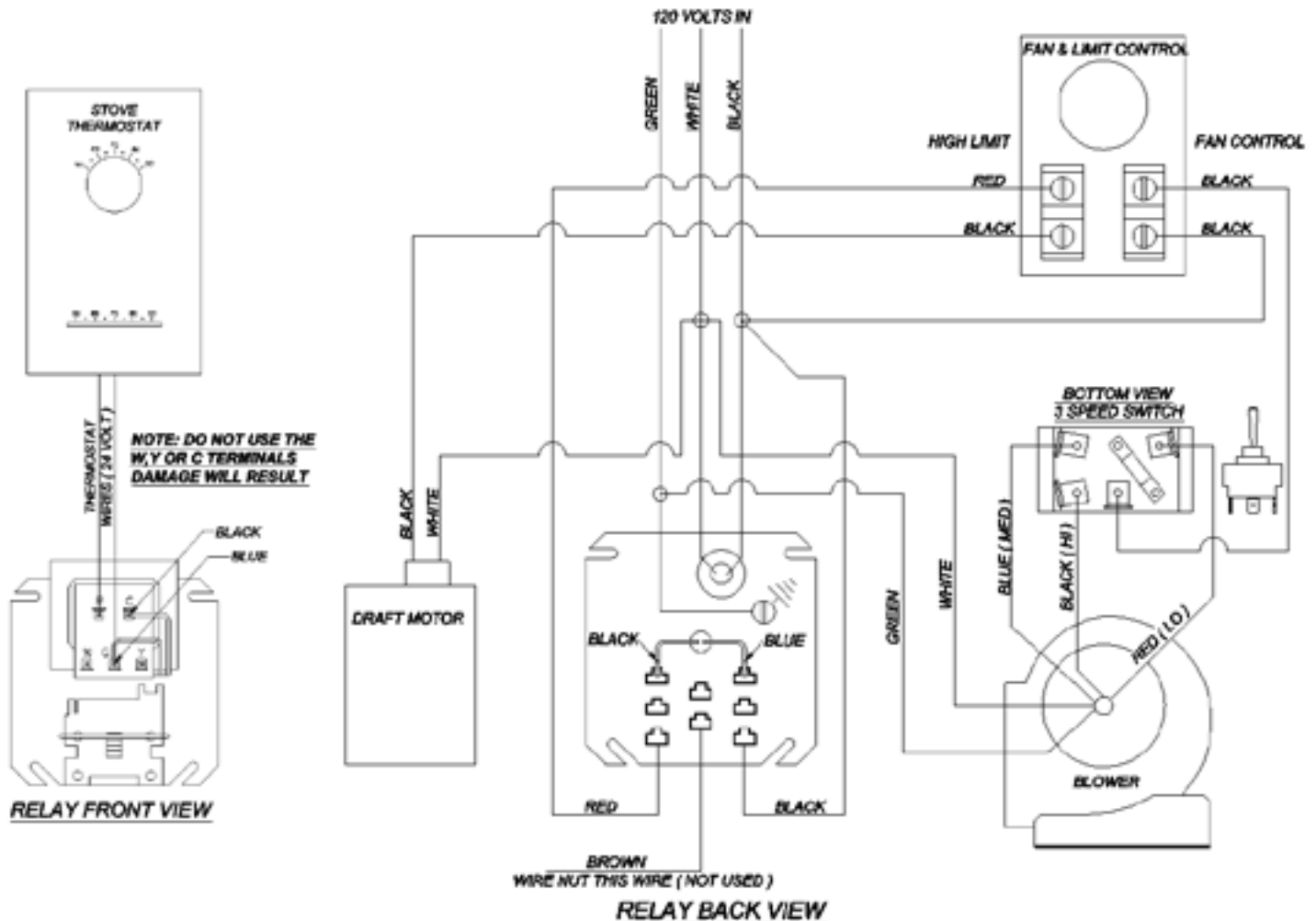

SF3500 Wiring Diagram

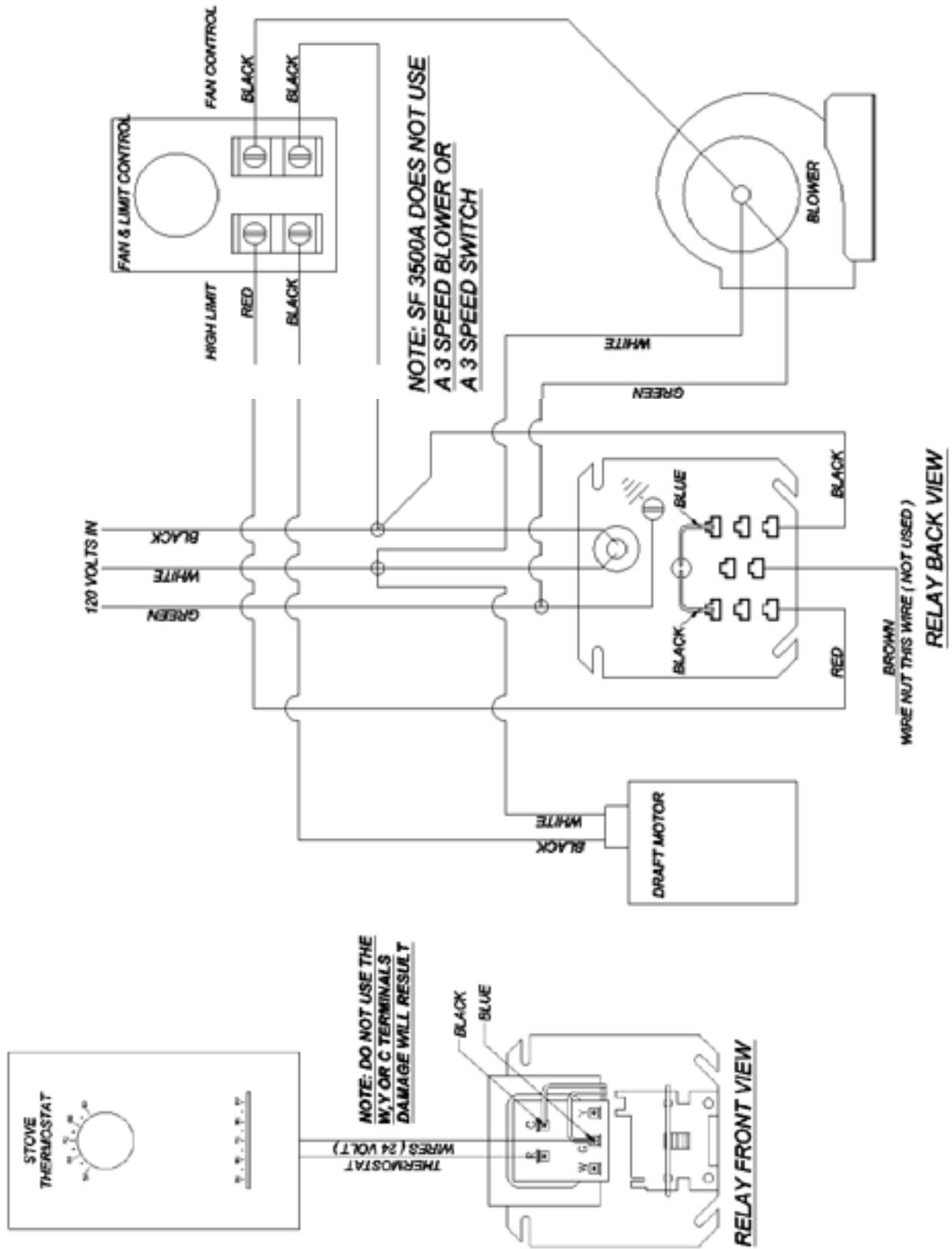

SF2600 Wiring Diagram

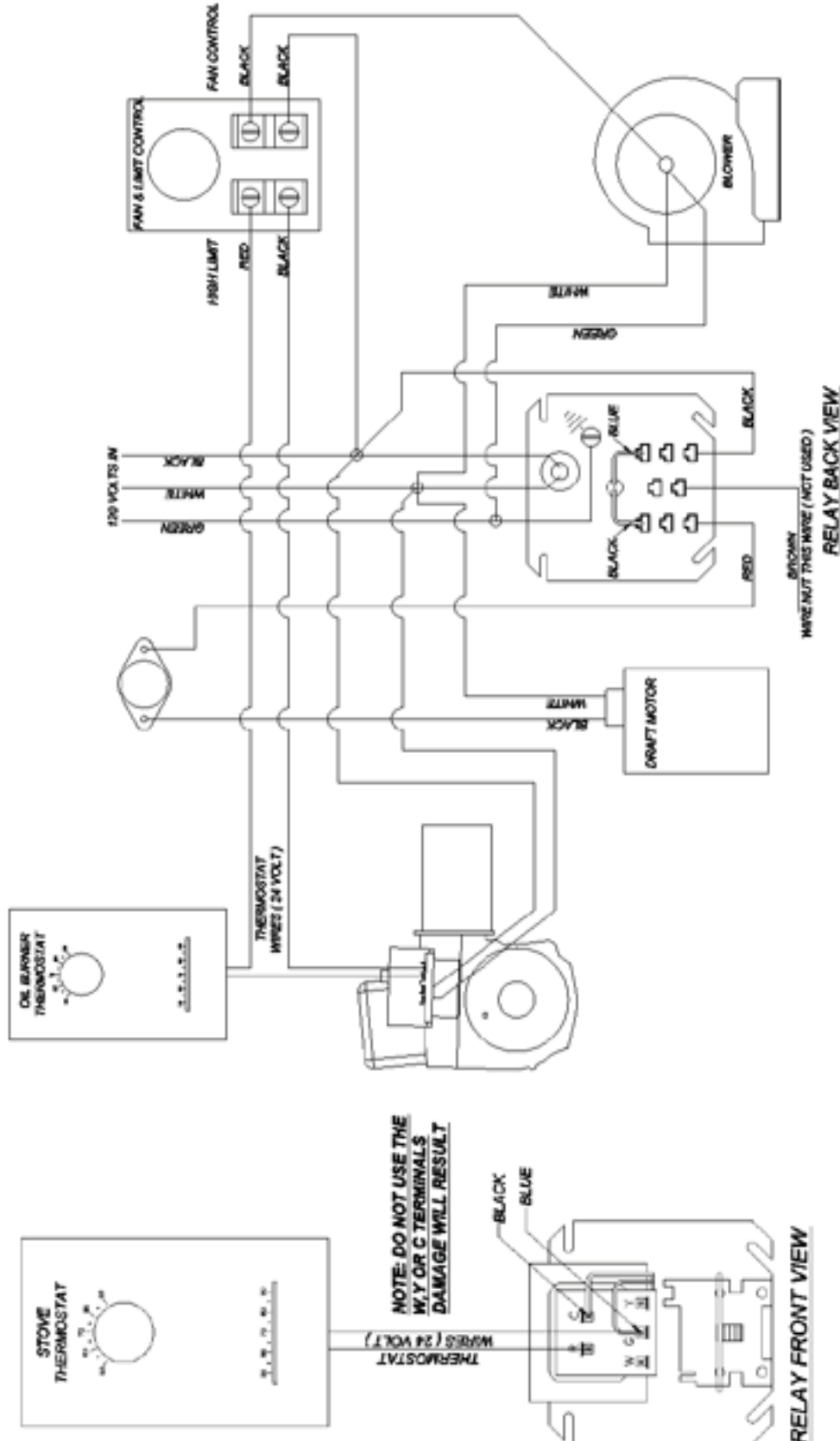

Duct Work and Operating Instructions

Duct Work.

This figure shows a typical duct system layout. Be sure the entire system is properly sized to provide the correct static pressure for optimum blower performance. Have any new duct system designed by a HVAC professional.

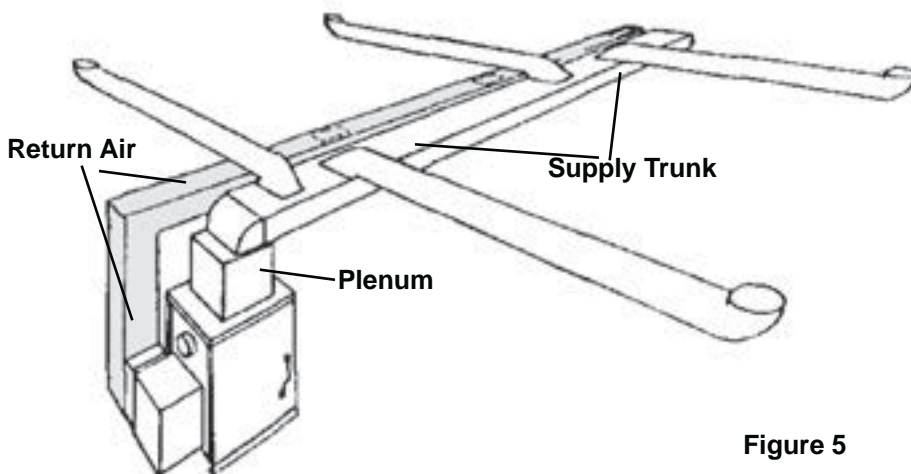

Figure 5

Operating Instructions

Adjusting Automatic Draft Control -

In order for your new furnace to function, the controls must be properly adjusted. The heat output is regulated by the automatic draft control on the bottom door of the furnace. Refer to the illustrations at right; The electric draft motor (A) opens and closes the flapper door (B). The flapper door opens to feed more air to the fire and closes to reduce the air to the fire. The maximum air flow can be adjusted by turning the adjuster bolt (C) counter-clockwise for more air and clockwise for less air. **NOTE** To preserve motor life, all adjustments of this bolt should be done while the flapper door is in the closed position. The idle adjuster (D) controls the minimum amount of air that enters the firebox when the flapper door is closed. Adjustment is made by turning the adjuster vertical for zero air or horizontal for maximum idle air. It is best to start at a medium setting as shown at right.

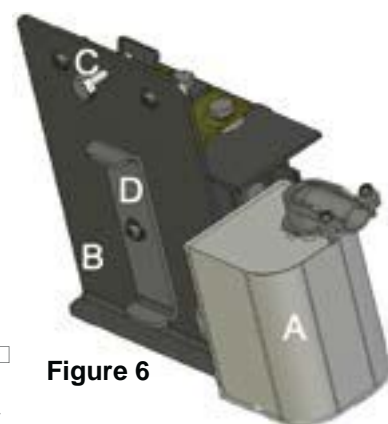

Figure 6

Adjusting the fan control- Shut off the power at the circuit breaker before removing the fan control cover. Make sure the copper jumper (circled below) is removed before using the furnace. Note the three pointers on the dial. The one on the right is the high limit adjustment. Pre-set at 200 degrees, its function is to close the automatic draft control flapper door if the temperature in the plenum reaches 200 degrees. **Do not change this setting.** The center pointer adjusts the temperature at which the blower starts. A good initial setting for this is 150 degrees. The pointer on the left is to adjust the temperature at which the blower stops. A good initial setting for this pointer is 100 to 110 degrees. If it is set too low, the air will feel cool coming out of the registers at the end of the blower cycle.



Figure 7

Thermostat- Set the thermostat to the desired temperature. When more heat is needed, the thermostat opens the automatic draft control flapper door. This allows air into the firebox, which raises the output of the fire. When the temperature in the plenum reaches the set temperature of the center pointer on the fan control, the blower will begin blowing heated air through the ductwork. When the thermostat reaches its setpoint, the automatic draft control closes the flapper door, thus, reducing the output of the fire. As the temperature in the plenum drops to the set point of the left pointer on the fan control, the blower will stop. A solid fuel fire cannot cease output immediately, therefore, your room temperature may exceed the thermostat setting at times. You also may notice times that the blower runs for a short period even though the draft control is closed. Again, you can't just stop a wood or coal fire instantly, and temperature may build enough to run the blower. This is normal and will be noticed more with coal than with wood.

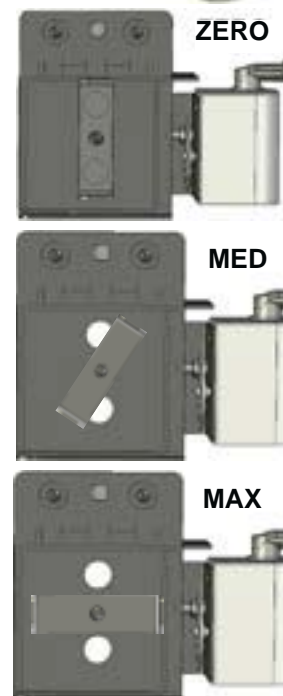

Operating Instructions

SF 2600 - Oil Operation as Backup -

The SF 2600 offers a unique option to the homeowner. The ability to have an efficient oil backup heat source built right into a wood/coal furnace.

The operation of the oil burner as a backup system is as simple as setting a thermostat. To use the oil portion of your furnace as a backup proceed as follows:

1. Set the wood/coal thermostat to the comfort level you desire.
2. Set the oil thermostat to a level 5 to 10 degrees but not less than 3 degrees lower than the wood/coal thermostat.

That's all there is to it. The idea is that when the wood/coal portion can no longer maintain the level set on that thermostat the oil portion will come on and maintain the temperature set on the oil thermostat.

SF 2600 - Oil Operation Only - In the oil only mode, simply turn the wood/coal thermostat to its lowest setting and select the comfort level you desire on the oil thermostat. The SF 2600 will now act as a standard oil burner and maintain your chosen temperature. **NOTE:** It is recommended that the wood/coal fire in the lower portion of the furnace be out or nearly out before going to "oil only" operation.

Curing Paint - During the first few hours of burning, a blue smoke will be observed rising from the painted surface of the furnace. It is advisable to increase the amount of fresh air in the room during this breaking-in period. This may be achieved by opening doors, windows, etc. Don't be alarmed. This is normal.

Starting a Wood Fire - Open the bottom door to increase the draft. Take about eight sheets of newspaper, crumbled into balls and place on top of the grates. Next, lay some fine kindling on top of the paper. This kindling must be dry and no larger than 3/4" diameter and should be layered in a criss-cross pattern to allow good air flow. Then, lay some slightly larger pieces (2" diameter) of wood on top of the kindling. Light the paper at the bottom, just inside the door. Now close loading door and allow kindling and wood to catch fire. After about five minutes, close the bottom door and open the loading door an inch or two for a few seconds before opening completely. This method will allow the smoke to clear away from the door opening. Now the fire should be well established and ready for some larger wood. Add four or five pieces of 3" to 4" diameter wood. Close loading door and open bottom door again. Let burn for about 5 minutes. Now open loading door using the same method as before, always closing the bottom door before opening the top door. Now load the firebox with wood to the desired fullness. All Harman furnaces may be loaded with wood as full as possible for high output and long burn time. Then close the door and allow all the wood to catch fire. The bottom door may again be opened to speed the process. The object is to get the wood burning well enough so it will not go out when the automatic draft shuts back to the idle setting. **NOTE:** When the bottom

door is open, the automatic draft cannot function to reduce the amount of air to the firebox. For this reason, the furnace could overheat.

WARNING: NEVER LEAVE THE BOTTOM DOOR OPEN WHILE FURNACE IS UNATTENDED!

After the wood is burning well, close the bottom door. The automatic draft control will now regulate the fire. The idle control (as shown on Fig. 6) on the flapper door must be adjusted so the fire does not go out or overheat. Experience will dictate the best setting. Normally the two manual draft controls on the loading door are kept closed to burn wood.

Starting A Coal Fire • Use the same procedure as for wood except do not go to large diameter wood. Use wood about 2" in diameter maximum. This size will form very hot wood coals in less time. Here again, the bottom door may be opened to speed the process. When a substantial bed of red wood coals are developed, start adding a thin layer of coal. Pea or nut sized coal is better for starting a fire than stove coal. When the first layer is burning with some blue flame, continue to add thin layers of coal until there is a solid bed of burning coal. Let each layer burn a blue flame before adding another layer. Layers can be added until the bed is approximately ten inches deep. This is about at the top of the firebrick. Most users find that if they keep the two manual draft controls open about one quarter turn, it helps keep the gasses burned off.

NOTE: Close the bottom door as soon as the desired coal bed is made.

Loading - Coal should never be added unless there is a reasonably hot fire. The coal bed should be bright and vigorous. If the fire is burning hot and there is a deep bed of coals, full loads of coal can be added at any time. However, if there is not a deep bed of coals, it is best to add small amounts of coal at first.

Shaking - Shaking should be done only when there is a well-established fire. The frequency of shaking will depend on the degree of burning. Shaking should be done whenever the furnace is refueled. Best results for shaking Harman grates will occur when short choppy strokes are used rather than long even strokes.

Operating Instructions/Safety Tips

The amount of shaking is critical. Too much will disrupt the fire bed and too little will restrict the air flow.

The proper amount normally occurs when red coals first start to drop through the grates into the ash pan.

Ashes - Ashes should never be allowed to accumulate in the ash pit so that they in any way impede the flow of combustion air to the fire. Excess ash accumulation can cause the fire to go out and also can cause severe damage to the grates because of the absence of a cooling flow of air beneath them.

Ashes should be placed in a metal container with a tight fitting lid. The closed container of ashes should be placed on a noncombustible floor or on the ground, well away from all combustible materials, pending final disposal. If the ashes are disposed of by burial in soil or otherwise locally dispersed, they should be retained in the closed container (outside the dwelling) until all cinders have thoroughly cooled.

CAUTION: ASHES SHOULD NEVER BE ALLOWED TO ACCUMULATE ABOVE THE TOP OF THE ASH PAN. ASHES IN CONTACT WITH THE BOTTOM OF THE GRATES ACT AS AN INSULATOR, INTENSIFYING THE HEAT ON THE GRATES, AND COULD CAUSE THEIR WARPAGE. WITH AN EXCESSIVE ASH BUILDUP, PRIMARY COMBUSTION AIR IS RESTRICTED. THUS THE UNIT'S OUTPUT COULD BE REDUCED.

Coal produces considerably more ash than wood. So the intervals between emptying are much shorter. For equal heat output, coal will produce seven to ten times more ash than wood.

Draft Control Settings - The idle air adjustment on the flapper door may need to be adjusted slightly less for coal than for wood. Here again, experience will dictate the best setting. The maximum air adjustment bolt can be set at the maximum position for quick recovery.

When a longer than normal burn time is desired, the maximum air adjustment can be reduced. After adjusting the maximum air bolt when the flapper door is opened. See Fig. 6 on page 11.

Safety Tips

When opening the loading door, it should be cracked open slightly for a few seconds to allow oxygen to burn any gases that may be present and to allow smoke to be drawn away from the door.

Whenever the bottom door is open, it should be closed before opening the loading door. This is to increase draft through the loading door and prevent excess smoke from escaping.

The firebox should never be filled with excessive coal so that the flue exit is blocked or impeded in any way. Burning coal generates carbon monoxide. If the flue gas exit is blocked, the carbon monoxide can be forced out of the furnace into the room with possible fatal consequences.

With the exception of start up or increasing heat from a low fire, or removing ashes, the bottom door should be kept closed. After install a Harman furnace to a chimney with a history of down drafts.

KEEP CHILDREN AWAY - MAY CAUSE SERIOUS BURNS.

CAUTION: ALL SURFACES OF FURNACE ARE HOT. DO NOT TOUCH. KEEP CHILDREN AWAY. SERIOUS BURNS WILL RESULT IF TOUCHED. THIS IS A HEAT PRODUCING APPLIANCE.

FUEL/FIRING WARNINGS -

DANGER! FIRE HAZARD! DO NOT USE CHEMICALS OR FLUIDS TO START OR "FRESHEN UP" A FIRE. SEVERE BODY BURNS OR A FIRE IN YOUR HOME COULD RESULT. DO NOT BURN GARBAGE, GASOLINE, THINNERS, DRAIN OR ENGINE OIL, KEROSENE, OR FUEL OIL, ETC. AN EXPLOSION, A HOUSE FIRE OR PERSONAL INJURY COULD RESULT. KEEP ALL SUCH LIQUIDS WELL AWAY FROM THE FURNACE WHILE IN USE.

Chimney Problems

Not Enough Draft - Chimney is too low. A chimney should be two feet higher than anything ten feet around it.

Air may be leaking in around a loose fitting clean-out door, flue pipe may not be tight at joints, or the masonry may be defective.

Chimney may be blocked with creosote or bird nests, etc.

Improper sized chimney or stove pipe.

Too many elbows.

Distance of more than eight feet between furnace and chimney.

Down Drafts - Trees or other topographical barriers may impede the chimneys operation causing a down draft condition to exist. This can also be caused by adjacent buildings or chimneys.

Creosote and Condensation - If creosote or condensation runs out of the chimney or stove pipe, check the following.

Chimney cap or lining may be defective.

Furnace may be too far from chimney, not allowing the chimney to get warm.

Wood being burned may be green or wet.

Unit may be too large for home causing wood to be burned too slow.

Excessive Draft - This can be controlled with a barometric draft control on the stove pipe.

Maintenance

Maintenance

The spiral chamber is basically self-cleaning. However, if there is a draft problem and you have been burning wood for a long time with little heat demand, the spiral chamber may need cleaning. Soft coal will also require more frequent cleaning. To clean, remove stovepipe and scrape the creosote from the front and top of the chamber and remove. The rear of the chamber will not accumulate creosote.

NOTE: 1/4" to 1/4" of creosote in the spiral chamber is normal. Creosote can be burned off by burning coal for a few days.

Firebricks may become cracked during the course of normal operation. A cracked brick that is still in place is still doing its job and need not be replaced immediately. If a brick is broken and has fallen out of place, it should be replaced immediately. The firebrick used in the Harman furnaces are inexpensive and easy to replace.

The blower manufacturer recommends the blower motor to be oiled once a year with 10 to 20 drops of light weight oil (check instructions packed in blower box).

Cleaning Heat-Exchanger (SF2600 Only) -

Remove oil burner by removing four mounting bolts. Burner can be tied up to ceiling to avoid hanging to remove the wiring. Next, remove the collar from the front cover and remove front cover by tilting out from top first. Now the heat exchanger will be exposed. Next, remove the four nuts that hold on the cover, then remove the cover. This will expose the inside of the heat exchanger. Remove spirals by simply pulling them out and clean the tubes with a brush. Reinstall spirals so they are flush with the end of the tube and reassemble unit in reverse of disassembly.

Specifications

	SF1500	SF2500	SF2600	SF3500
	<u>Complete</u>	<u>Complete</u>	<u>Complete</u>	<u>Complete</u>
Heating Capacity- square ft.	2200	3200	3200	4200
Approximate BTU Input	90,000	120,000	120,000	170,000
Blower Size	1000 cfm	1000 cfm	1450 cfm	1450 cfm
Automatic Draft	Standard	Standard	Standard	Standard
Filter Box & Filter	Standard	Standard	Standard	Standard
3-Speed Fan Switch	Standard	Standard	Single Speed	Single Speed
Fan Control / High Limit	Standard	Standard	Standard	Standard
Thermostat	Standard	Standard	Standard	Standard
Domestic Hot Water Coil	Optional	Optional	Optional	Optional
Firebox Dimensions - Inches	16Wx22Lx20.5H	18Wx26Lx21.5H	18Wx26Lx21.5H	18Wx30Lx25H
Recommended Log Length	18 in	22 in	22 in	27 in
Maximum Log Length	22 in	26 in	26 in	30 in
Flue Size	6 in	7 in	7 in	7 in
Filter Size	14 X 20	14 X 20	14 X 20	14 X 20
Number of Grates	4	5	5	6
Weight	500 Lbs	700 Lbs	900 Lbs	1000 Lbs
Plenum Dimensions	20 X 20	20 X 20	20 X 25	20 X 25
Clearance to Combustibles- Rear	30 in	30 in	30 in	30 in
Clearance to combustibles- Side	24 in	24 in	24 in	24 in

Dimensions:

A:	25 in	26 in	28 in	28 in
B:	20 in	20 in	20 in	20 in
C:	46.5 in	47.5 in	57 in	52.5 in
D:	27.75 in	31 in	31 in	36 in
E:	20 in	20 in	25 in	25 in
F:	40 in	41.75 in	40.5 in	45 in
G:	16.5 in	16.5 in	16.5 in	16.5 in
H:	44.5 in	47.5 in	48 in	52.5 in
K:	27.5 in	27.5 in	27.5 in	27.5 in

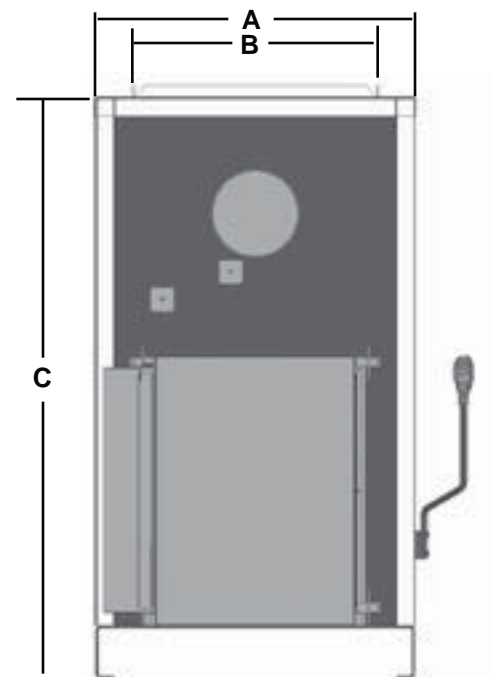
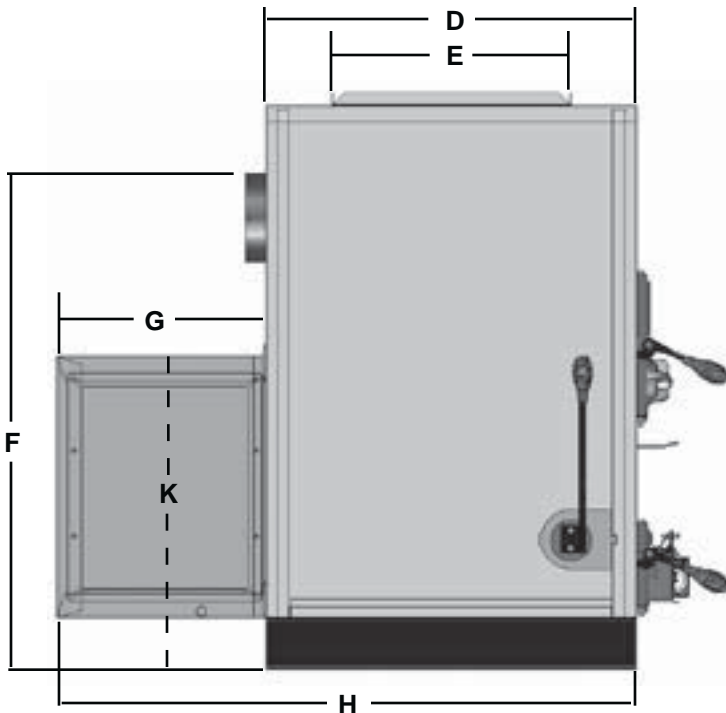

Special Instructions

Coil Installation:

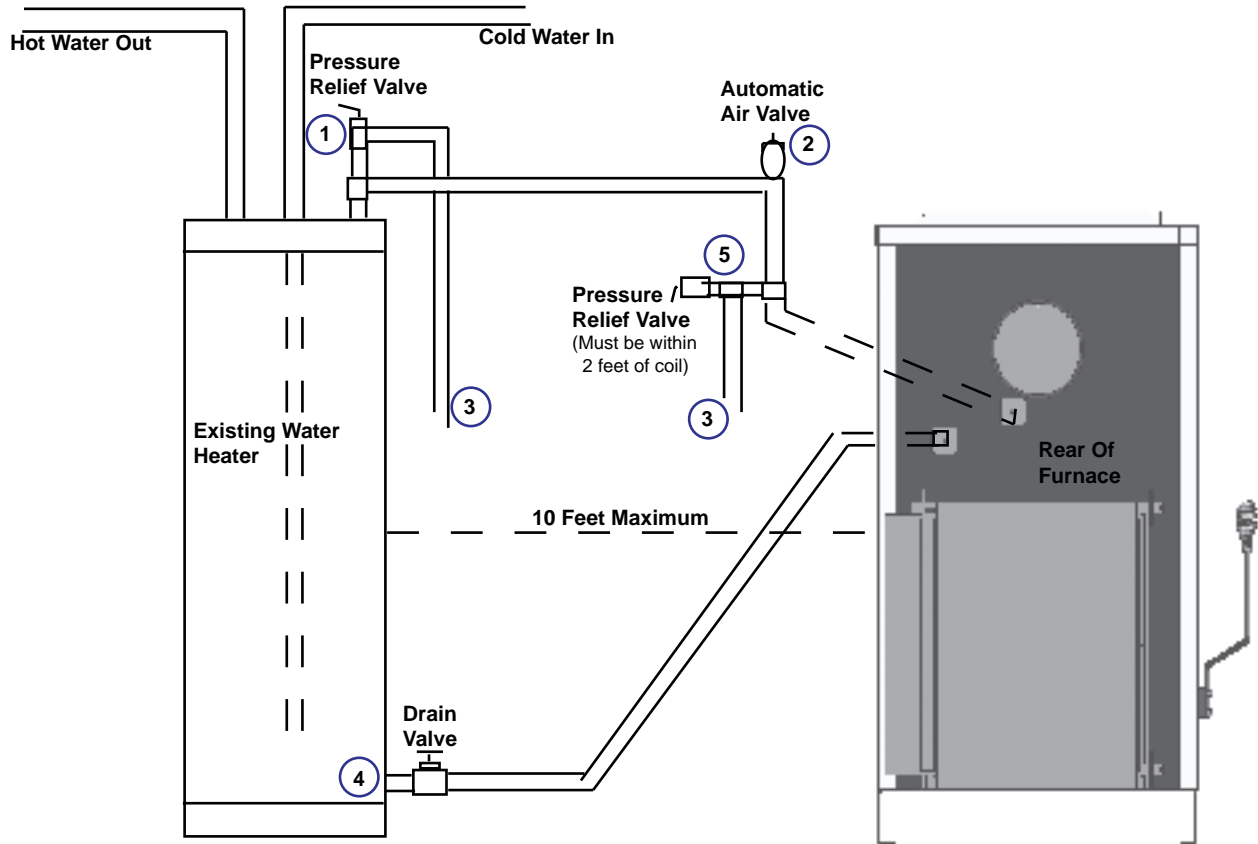

Plumbing Diagram For Thermo-Siphon Method - Maximum Distance = 10 Feet

Place one of the supplied nuts on each leg of the coil. Place the coil through the holes on the back of the furnace and adjust the nuts so that the pipes stick out about 1¼ to 1½ inches from the rear of the furnace. Place the flat washers and gaskets over each pipe and tighten the nuts. You are now ready to run the piping.

This simple method is the most economical. However, the existing water heater must be less than 10 feet from the furnace. The water inlet, where the Temperature / Pressure Relief Valve is located, must be higher than the top leg of the water coil. The water heater should be elevated, if necessary, to allow for proper thermo-siphon action. (The method by which hot water will circulate automatically through the system.)

A. Shut off the water heater and the water supply to it. Drain the tank completely.

B. Remove the Temperature / Pressure relief Valve and discard. Install a short ¾ in. nipple and tee (1) along with a new relief Valve.

C. Run ¾ in. copper tubing between the water tank and the top leg of the coil. Install a ¾ in. vent elbow and automatic "float type" air Vent in the high point of the line. Within 2 feet of the top leg of the coil, install a 150 lb. pressure relief Valve (5). Run ¾ in. tubing from the release exit of both relief Valves downward (3) so the hot water can escape in the event of an overheat situation.

D. Remove the drain Valve at the bottom of the tank. Install a short ¾ in. nipple and tee and re-install the drain Valve to the tee (4). Run ¾ in. tubing between the drain / tee combination and the lower leg of the water coil. After all of the connections are secured, refill the water tank. *Turn on the water heater only after the tank has been completely refilled.*

Special Instructions

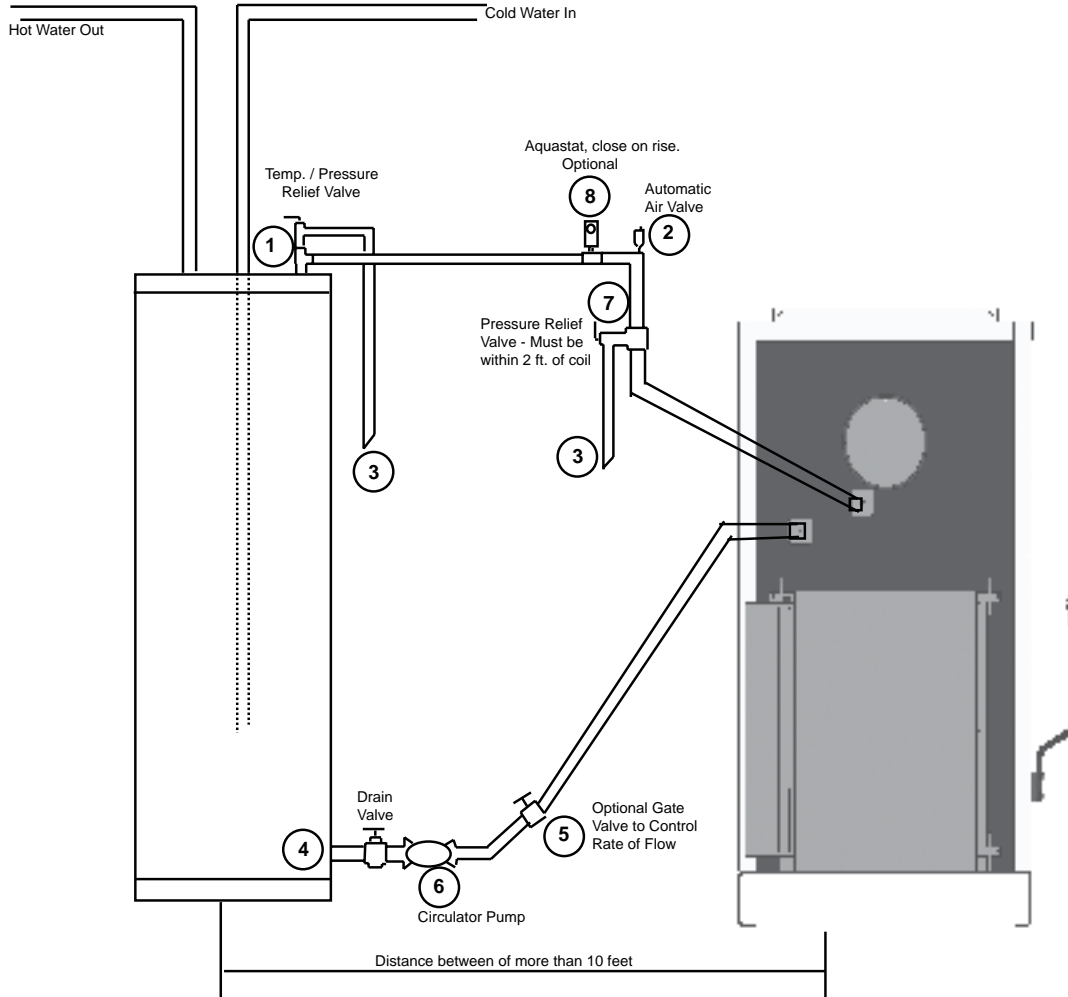

Circulating Pump Method - Distance = 10 Feet or More

This method is used when the water heater tank is more than ten feet away from the furnace or the furnace is on a higher level than the water heater tank. In addition to a circulator pump, you may want to add an aquastat to thermostatically control the pump according to water temperature. This is optional and not necessary if the circulator pump is left run continuously. Another option is a gate valve placed near the pump to control the rate of water flow.

- A. Shut off the water heater and the water supply to it. Drain the tank completely.
- B. Remove the Temp./ Pressure relief valve and discard. Install a short 3/4 in. nipple and tee (1) along with a new relief valve.
- C. Remove the drain valve at the bottom of the tank. Install a short 3/4 in. nipple and tee and re-install the drain valve to the tee (4).
- D. Install a circulator pump as shown (6). Run 3/4" copper tubing from the circulator pump to the lower leg of the water coil. This is where the optional gate valve (5) can be installed to regulate flow.
- E. Install a 3/4 in. tee and a 150 lb. Pressure relief valve (7) in the top leg within two feet of the coil.
- F. Complete the 3/4 in. line by running it back to the tee at the top of the water heater tank. Be sure to install the 3/4 in. vent elbow and automatic air vent (2) at the high point of the line. The optional aquastat can be installed in this line a maximum of 6 feet from the furnace. This aquastat must close on rise in temperature and must be hooked up to turn on the circulator when the water temperature reaches 120°F.
- G. After securing all connections, refill the tank with water and then, ONLY THEN, turn on the power to the water heater.

SF2600 Burner Set Up

SF2600 Oil Burner Setup

Oil

Off Cycle Damper Setting (B)

Flamelock Setting (A)

Combustion Air (C)

Draft - (Inches of water column)

0 Degree Solid Cone

1 (as low as it goes)

1

1 to 1

06 to 0

Tests for CO must be made without a fire in the wood/ coal firebox and with all doors and draft controls completely closed. The burner should be fired for several minutes prior to taking a reading. Normal CO reading is 11 to 12 with a stack temperature of 300 degrees or less. This would give you an efficiency of 4 to 5 percent.

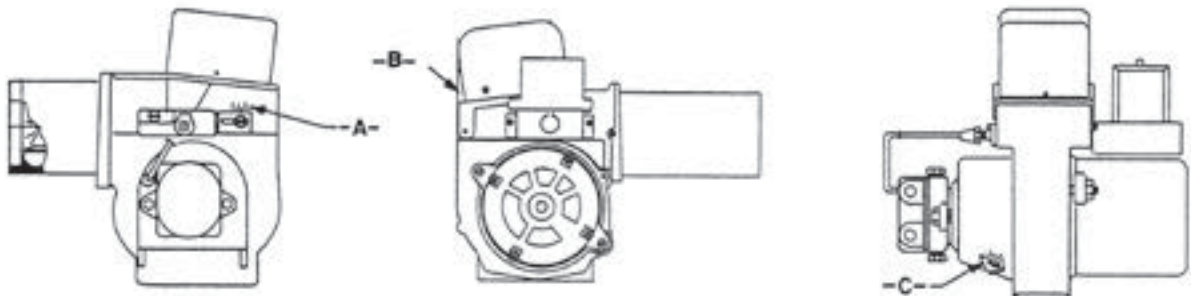
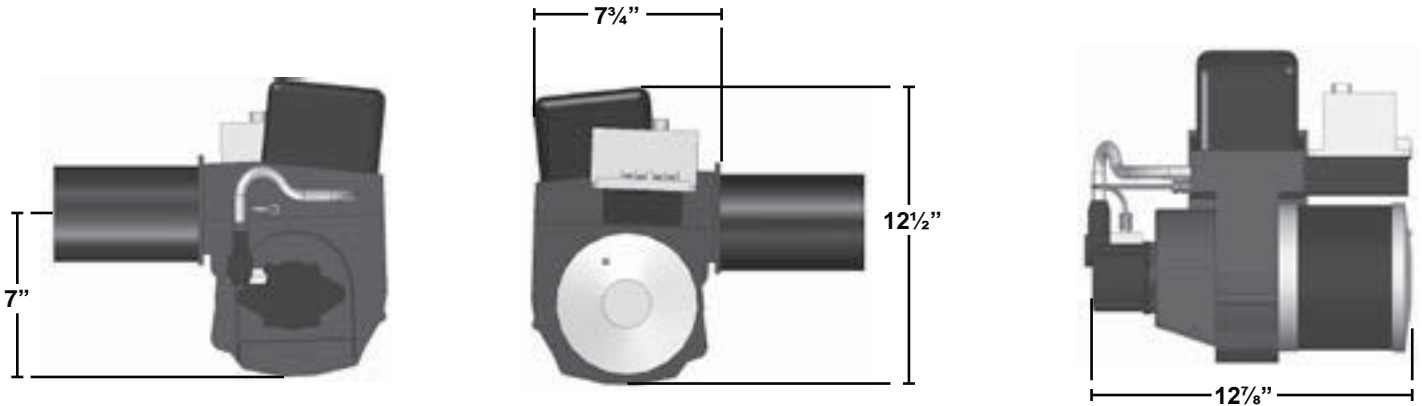

Warranty

Hearth & Home Technologies LIMITED LIFETIME WARRANTY

Hearth & Home Technologies on behalf of its hearth brands ("HHT") extends the following warranty for HHT gas wood pellet coal and electric hearth appliances that are purchased from an HHT authorized dealer

WARRANTY COVERAGE:

HHT warrants to the original owner of the HHT appliance at the site of installation and to any transferee taking ownership of the appliance at the site of installation within two years following the date of original purchase that the HHT appliance will be free from defects in materials and workmanship at the time of manufacture After installation if covered components manufactured by HHT are found to be defective in materials or workmanship during the applicable warranty period HHT will at its option repair or replace the covered components HHT at its own discretion may fully discharge all of its obligations under such warranties by replacing the product itself or refunding the verified purchase price of the product itself The maximum amount recoverable under this warranty is limited to the purchase price of the product This warranty is subject to conditions exclusions and limitations as described below

WARRANTY PERIOD:

Warranty coverage begins on the date of original purchase In the case of new home construction warranty coverage begins on the date of first occupancy of the dwelling or six months after the sale of the product by an independent authorized HHT dealer/ distributor whichever occurs earlier The warranty shall commence no later than 24 months following the date of product shipment from HHT regardless of the installation or occupancy date The warranty period for parts and labor for covered components is produced in the following table

The term "Limited Lifetime" in the table below is defined as: 20 years from the beginning date of warranty coverage for gas appliances and 10 years from the beginning date of warranty coverage for wood pellet and coal appliances These time periods reflect the minimum expected useful lives of the designated components under normal operating conditions

Warranty Period		HHT Manufactured Appliances and Venting							Components Covered
Parts	Labor	Gas	Wood	Pellet	EPA Wood	Coal	Electric	Venting	
1 Year		X	X	X	X	X	X	X	All parts and material except as covered by Conditions Exclusions and Limitations listed
2 years				X	X	X			Igniters electronic components and glass
		X	X	X	X	X			Factory-installed blowers
				X					Molded refractory panels
3 years				X					Firepots and burnpots
5 years	1 year			X	X				Castings and baffles
7 years	3 years		X	X	X				Manifold tubes HHT chimney and termination
10 years	1 year	X							Burners logs and refractory
Limited Lifetime	3 years	X	X	X	X	X			Firebox and heat exchanger
90 Days		X	X	X	X	X	X	X	All replacement parts beyond warranty period

See conditions exclusions and limitations on next page

Warranty

WARRANTY CONDITIONS:

- This warranty only covers HHT appliances that are purchased through an HHT authorized dealer or distributor. A list of HHT authorized dealers is available on the HHT branded websites.
- This warranty is only valid while the HHT appliance remains at the site of original installation.
- This warranty is only valid in the country in which the HHT authorized dealer or distributor that sold the appliance resides.
- Contact your installing dealer for warranty service. If the installing dealer is unable to provide necessary parts, contact the nearest HHT authorized dealer or supplier. Additional service fees may apply if you are seeking warranty service from a dealer other than the dealer from whom you originally purchased the product.
- Check with your dealer in advance for any costs to you when arranging a warranty call. Travel and shipping charges for parts are not covered by this warranty.

WARRANTY EXCLUSIONS:

This warranty does not cover the following:

- Changes in surface finishes as a result of normal use. As a heating appliance, some changes in color of interior and exterior surface finishes may occur. This is not a flaw and is not covered under warranty.
- Damage to printed, plated, or enameled surfaces caused by fingerprints, accidents, misuse, scratches, melted items, or other external sources and residues left on the plated surfaces from the use of abrasive cleaners or polishes.
- Repair or replacement of parts that are subject to normal wear and tear during the warranty period. These parts include paint, wood, pellet and coal gaskets, firebricks, grates, flame guides, batteries and the discoloration of glass.
- Minor expansion, contraction, or movement of certain parts causing noise. These conditions are normal and complaints related to this noise are not covered by this warranty.
- Damages resulting from: (1) failure to install, operate, or maintain the appliance in accordance with the installation instructions, operating instructions, and listing agent identification label furnished with the appliance; (2) failure to install the appliance in accordance with local building codes; (3) shipping or improper handling; (4) improper operation, abuse, misuse, continued operation with damaged, corroded or failed components, accident, or improperly/incorrectly performed repairs; (5) environmental conditions, inadequate ventilation, negative pressure, or drafting caused by tightly sealed constructions, insufficient make-up air supply, or handling devices such as exhaust fans or forced air furnaces or other such causes; (6) use of fuels other than those specified in the operating instructions; (7) installation or use of components not supplied with the appliance or any other components not expressly authorized and approved by HHT; (8) modification of the appliance not expressly authorized and approved by HHT in writing; and/or (9) interruptions or fluctuations of electrical power supply to the appliance.
- Non-HHT venting components, hearth components or other accessories used in conjunction with the appliance.
- Any part of a pre-existing fireplace system in which an insert or a decorative gas appliance is installed.
- HHT's obligation under this warranty does not extend to the appliance's capability to heat the desired space. Information is provided to assist the consumer and the dealer in selecting the proper appliance for the application. Consideration must be given to appliance location and configuration, environmental conditions, insulation and air tightness of the structure.

This warranty is void if:

- The appliance has been over-fired or operated in atmospheres contaminated by chlorine, fluorine, or other damaging chemicals. Over-firing can be identified by, but not limited to, warped plates or tubes, rust colored cast iron, bubbling, cracking and discoloration of steel or enamel finishes.
- The appliance is subjected to prolonged periods of dampness or condensation.
- There is any damage to the appliance or other components due to water or weather damage which is the result of, but not limited to, improper chimney or venting installation.

LIMITATIONS OF LIABILITY:

- The owner's exclusive remedy and HHT's sole obligation under this warranty, under any other warranty, express or implied, or in contract, tort or otherwise, shall be limited to replacement, repair, or refund, as specified above. In no event will HHT be liable for any incidental or consequential damages caused by defects in the appliance. Some states do not allow exclusions or limitation of incidental or consequential damages, so these limitations may not apply to you. This warranty gives you specific rights; you may also have other rights, which vary from state to state. EXCEPT TO THE EXTENT PROVIDED BY LAW, HHT MAKES NO EXPRESS WARRANTIES OTHER THAN THE WARRANTIES SPECIFIED HEREIN. THE DURATION OF ANY IMPLIED WARRANTY IS LIMITED TO THE DURATION OF THE EXPRESSED WARRANTY SPECIFIED ABOVE.



At Harman, we build each product to a standard, not a price.

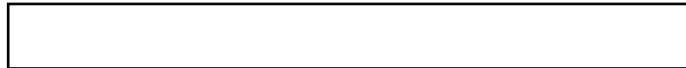

(Signature of Boxer)

Your premium quality hearth product designed and assembled by the experienced and skilled members at Harman in Halifax, PA, USA.

HARMAN[®]

BUILT TO A STANDARD, NOT A PRICE

Proudly Printed On 100% Recycled Paper

