

# INVINCIBLE PELLET INSERT OWNERS MANUAL

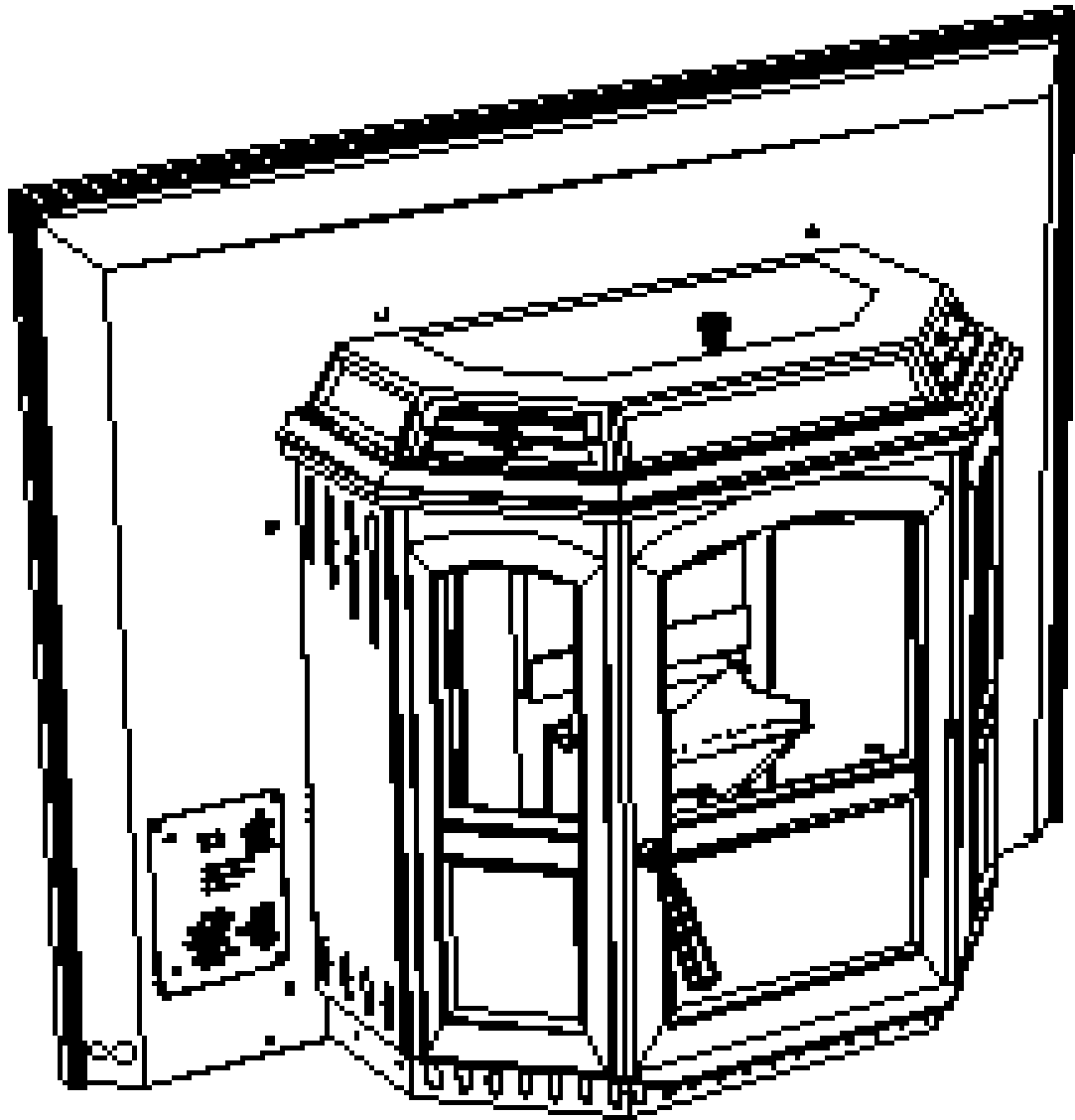

R4

# **Contents**

<b>Packing List</b>	<b>3</b>
<b>Installation &amp; Assembly</b>	<b>3</b>
<b>Operation</b>	<b>7</b>
<b>ESP Control</b>	<b>10</b>
<b>Maintenance</b>	<b>11</b>
<b>Trouble Shooting</b>	<b>13</b>
<b>Wiring Diagram</b>	<b>14</b>
<b>Feeder Parts</b>	<b>15</b>
<b>Specifications</b>	<b>16</b>

**Manufactured by  
Harman Stove Company  
352 Mountain House Road  
Halifax Pa. 17032  
(717) 362-9080**

# Packing List

## Inside Stove:

### Hardware Pack

- (2) Electrical Terminals
- (1) 10-32 x 1/2" Bolt
- (1) 1/4 x 20 x 2 1/2" Bolt
- (1) Wooden Handle
- (1) Brass Knob
- (1) Control Board Wired to Stove
- (1) Owners Manual
- (1) Warranty Activation Coupon
- (1) Room Sensing Probe
- (2) Side Panels
- (1) Ash Pan

- (2) Firebricks

- (1) Scraper
- (1) Flame Guide
- (1) Cleaning Brush
- (2) 1/2 x 12" Threaded Rods

## Inside Wing box

- (1) Air Intake Grill
- (1) Hardware Pack
  - (6) 1/4 x 20 x 1/2 Bolts
  - (6) 10-32 x 1/4 Bolts
  - (2) 10-32 Nuts
- (1) Set of Brass Trim for Wings

# Assembly and Installation

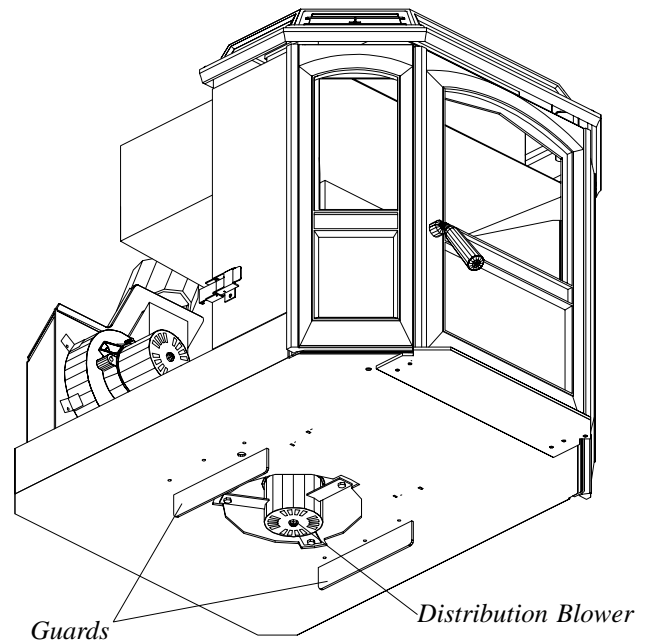
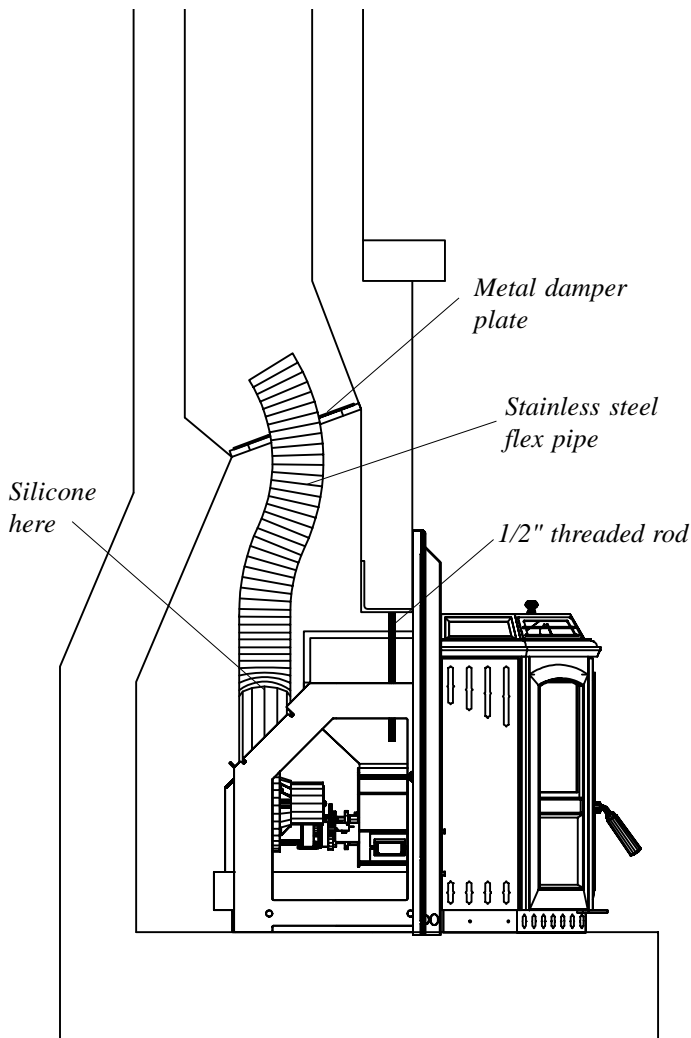

*Be careful not to damage the distribution blower located under the insert. There are guards on both sides of the motor to allow the insert to rest on a flat surface, however, extra care should still be taken.*

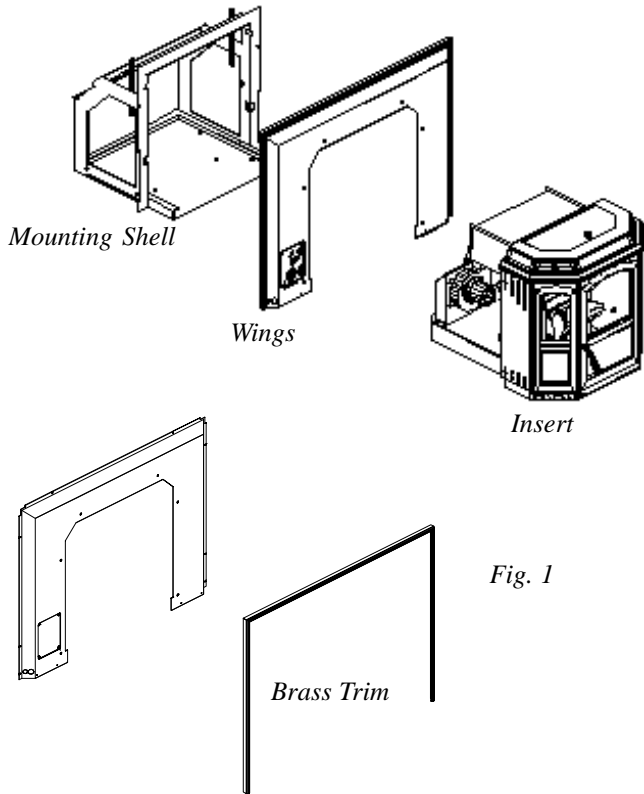

After leveling, tighten the two 1/2" threaded rods up against the fireplace lintel.

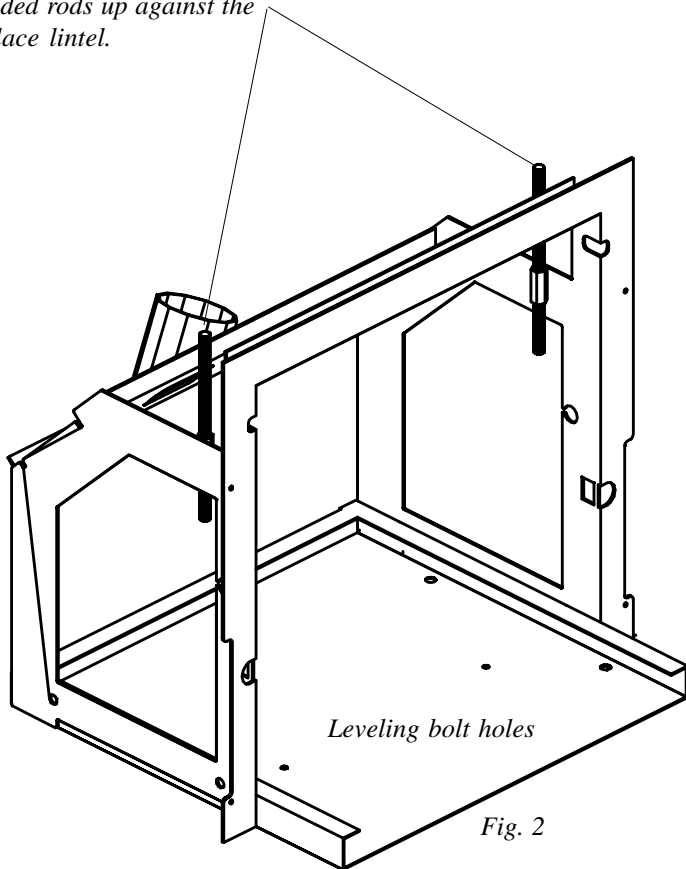

The Invincible Insert is made up of three main parts. They are the mounting shell, the wings, and the stove insert, fig. 1.

A unique feature of this unit is the fact that the insert can be removed from the fireplace for service without removing the mounting shell, the wings or disconnecting the flue pipe.

Please note that the insert extends through the rear of the mounting shell and this distance needs to be considered when installing the shell. The easiest place to see this is before you remove the unit from the skid, fig.3.

### Installing the Mounting Shell

Before installation, remove the damper and any accessories from the fireplace. It is intended that a four inch stainless steel flex pipe shall be connected to the pipe on the rear of the mounting shell and extend up through the damper opening. The pipe shall be sealed at the damper opening with a metal plate or packed with fiberglass.

Install brass trim on wings with hardware provided. Bolt wings to shell with button head bolts.

Place flex pipe up through damper opening and seal around the pipe. The pipe should be able to slide down over the flue on the shell, and sealed with high temp silicone.

Place shell with wings attached into the fireplace. Level the wings in all directions with the leveling bolts in the base of the shell. After leveling, tighten the two 1/2" threaded rods up against the fireplace lintel, fig. 2. Do not over-tighten.

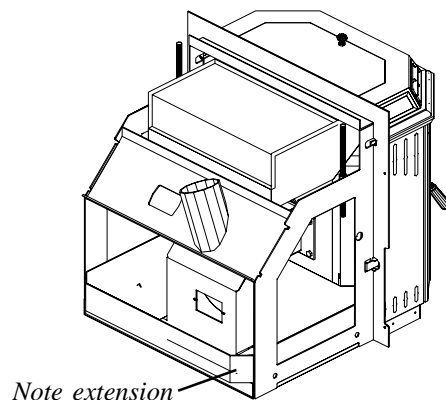

Fig. 3

## Installing Insert

Slide two four foot long wood 2 x 4's into the bottom of the shell as shown in fig. 4. Support the ends of the 2 x 4's by cutting two pieces the proper height for your hearth. A cross brace between the two supports is recommended.

Place the insert on top of the 2 x 4's and slide back until the bottom is started onto the shell.

Unpack the control board and install. This can be done with the wiring attached by bringing the control through the wing from the back. The control can be mounted from the front if the wiring harness is disconnected and reconnected after

mounting. Be sure to put the green wires on the stud behind the wing. This stud also has the green wire from the power cord on it, fig 5.

Next slide the insert to within an inch of home position. Align the latches on the sides of the insert and slide in the rest of the way. Always be sure no wires are being pinched. Latch the two latches and remove the 2 x 4's. Reattach the side panels and bottom air intake grill, fig. 6.

Place the Room Sensing Probe in the desired location and run standard thermostat wire back to the terminals on the left wing and connect with the two terminals provided, fig. 7. Connect the power cord to a 120 volt receptacle.

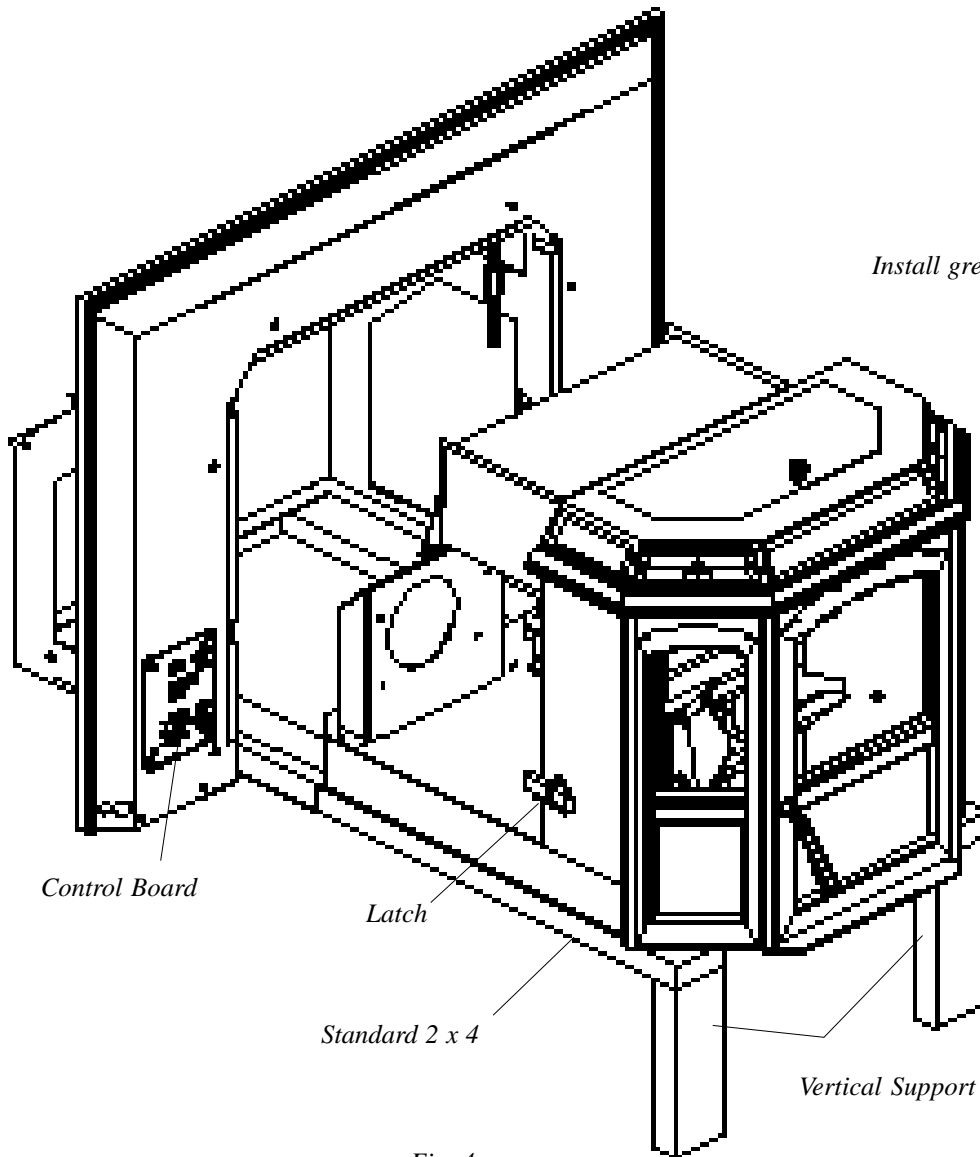

Fig. 4

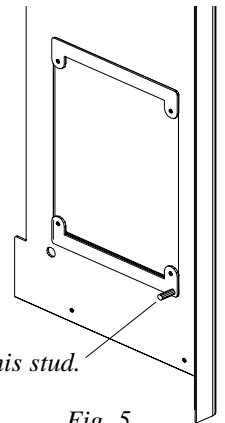
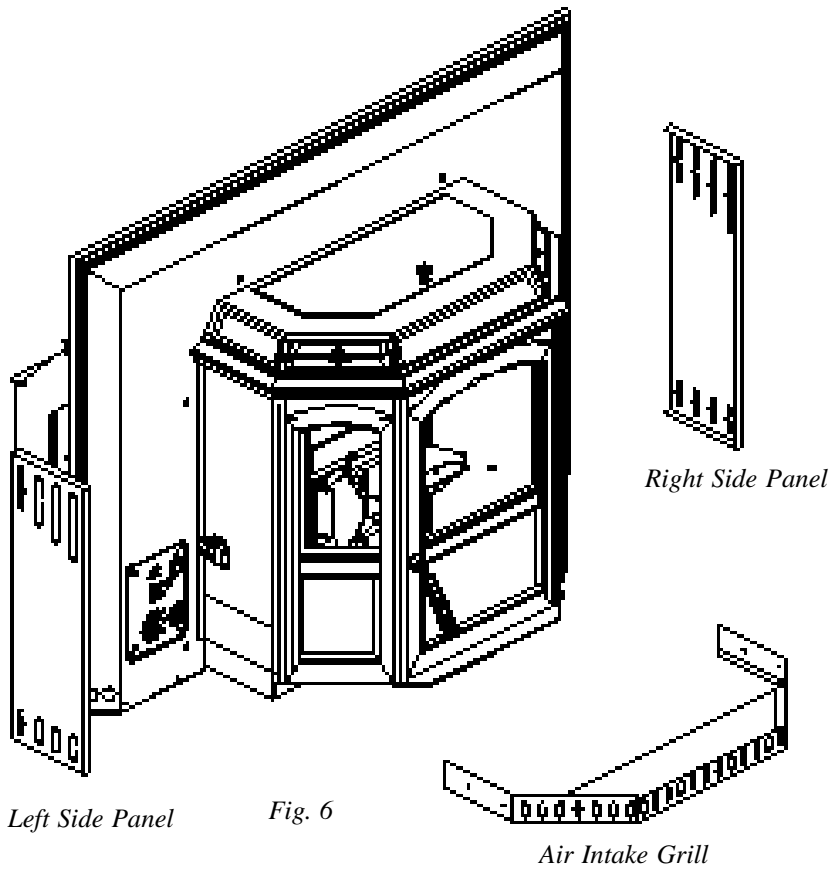

Fig. 5



### Final Assembly

Install Wooden Door Handle with 1/4 x 20 x 2 1/2 bolt.

Install Brass Hopper Knob with 10-32 x 1/2 bolt.

Install the two Firebricks on the angle iron behind the burn pot as shown in fig. 7.

Remove tape from Flame Guide and make sure it is resting on the burn pot as shown in fig. 7.

Put the ash pan back in the stove.

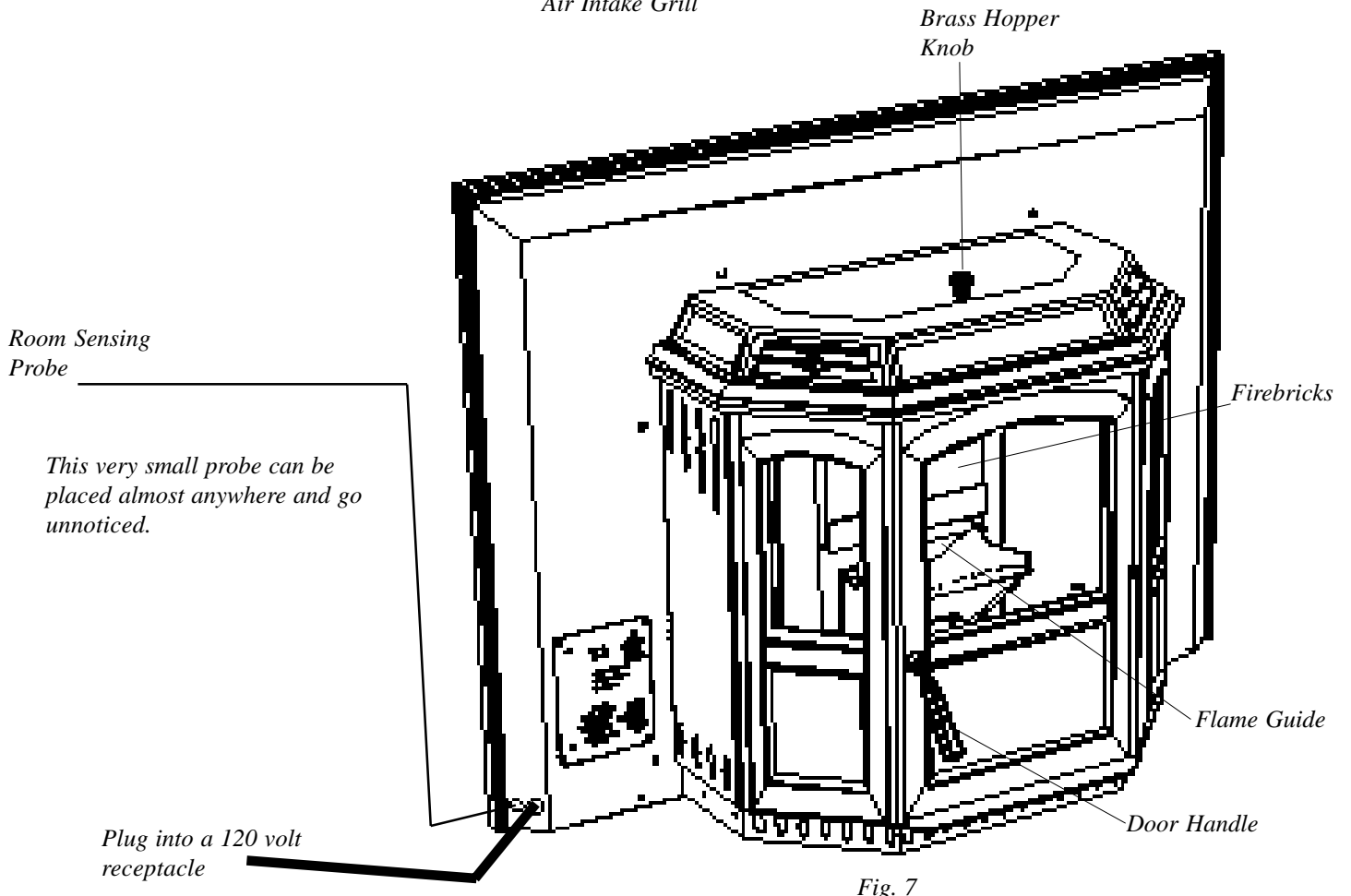

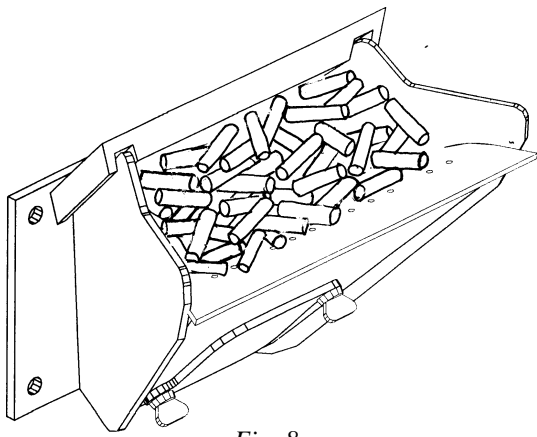

Fig. 8

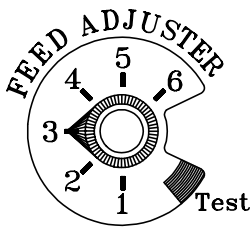

Fig. 9

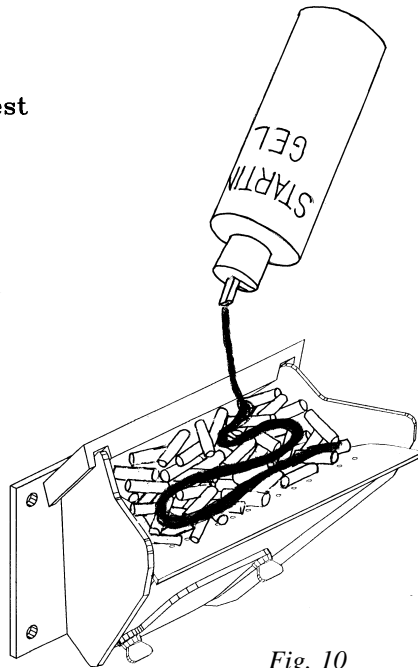

Fig. 10

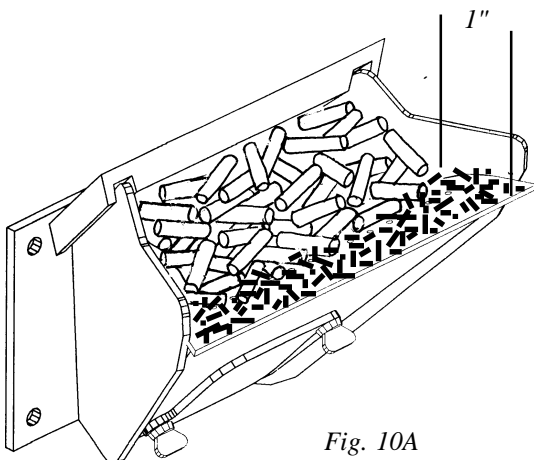

Fig. 10A

# Operation

## Starting First Fire

Be sure the power cord is plugged into a 120 volt receptacle. This can be verified by the red power light on the control panel.

**Fill the hopper** with pellets, fig. 12.

**Fill the burn pot** with pellets to a level just short of overflowing, fig. 8.

**Adjust feed rate.** If this is your first fire or you are trying different pellets, set the feed adjuster to "3", fig. 9. This is a conservative number and will probably need to be increased. After you know a feed rate setting that works well, use that setting. Remember too high a feed rate will waste fuel.

**Turn Mode selector to "OFF" and then to "Stove Temp".** This will turn the combustion blower to high. When starting a fire always turn the mode selector to "OFF" before selecting the desired mode. This resets the control for start-up.

**Turn Temp Dial to 7.** This will allow the stove to burn at maximum for feed rate adjusting purposes.

**Apply starting gel** to pellets in burn pot and **light** the gel. Close the door after lighting.

At this point the distribution and combustion lights will be on and the feed motor light will be off.

As the temperature of the fire increases, the feed motor light will come on and pellets will feed into the burn pot. As the stove temperature increases the distribution blower speed will increase.

After 30 to 45 minutes it may be necessary to **readjust the feed rate.** The feed rate should be adjusted so there is about one inch of ash in front of the fire, fig. 10A.

*Scrape floor of burn pot with scraper to remove any carbon build-up before starting a new fire.*

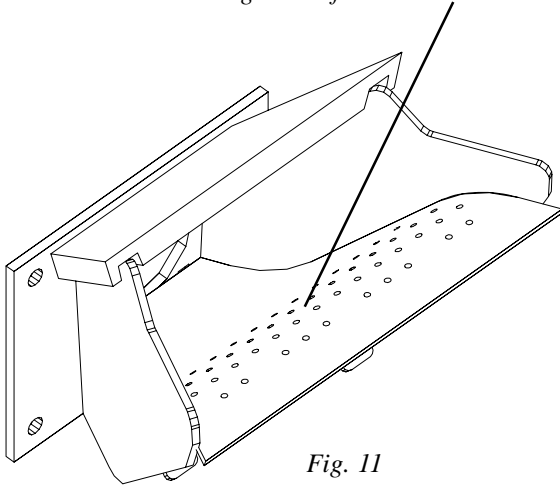

Fig. 11

*When filling hopper be sure to remove any pellets from ledge before closing lid.*

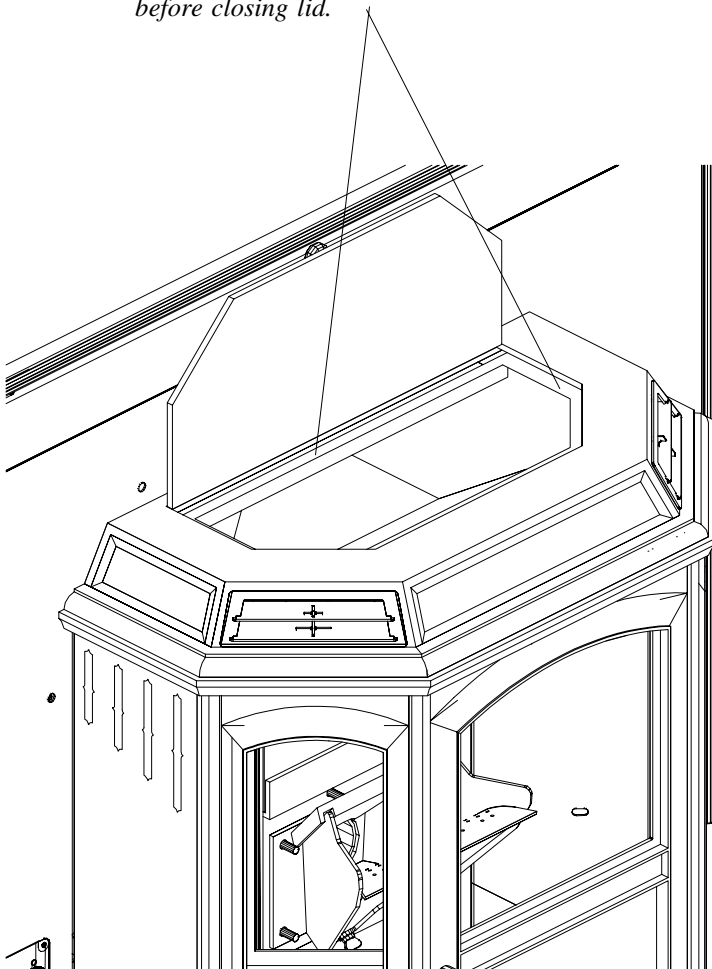

Fig. 12

## **Starting a fire after proper Feed Rate is known.**

**Clean burn pot with scraper** (supplied).

**Fill the hopper** with pellets.

**Fill the burn pot** with pellets to a level just short of overflowing.

**Adjust feed rate to proper setting.**

After you know what feed rate works well, then use that setting. (For example a setting of "5" produces 1" or more of ash on the burn pot with the brand of pellets you are using.) Remember, too high a feed rate will waste fuel.

**Turn Mode selector to "OFF" and then to the desired mode.**

**Turn Temp Dial to the desired temperature.** In Room Temp Mode this would be the outer scale marked in degrees. In Stove Temp Mode this would be the inner scale marked from 1 to 7.

**Apply starting gel** to pellets in burn pot as shown on fig. 10 and **light** the gel. Close the door after lighting.

At this point the distribution and combustion lights will be on and the feed motor light will be off. As the temperature of the fire increases, the feed motor light will come on and pellets will feed into the burn pot. As the stove temperature increases the distribution blower speed will increase.



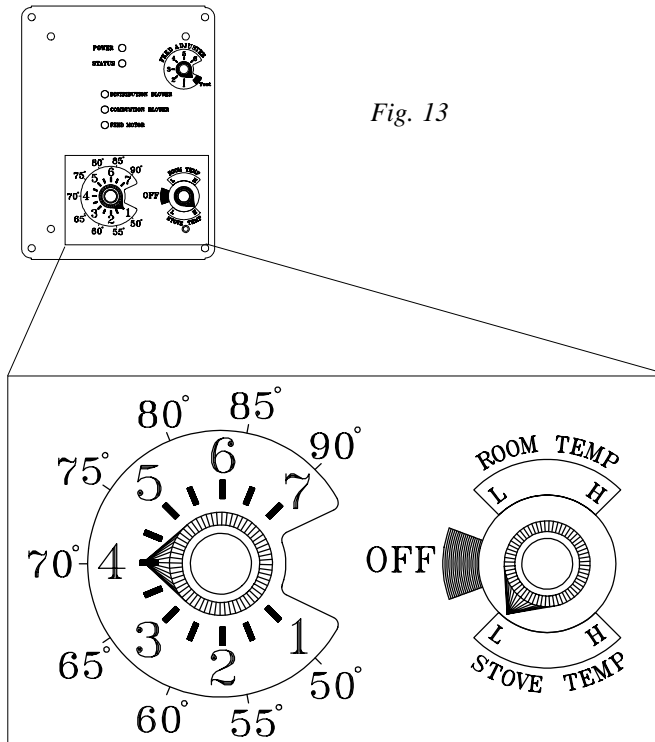
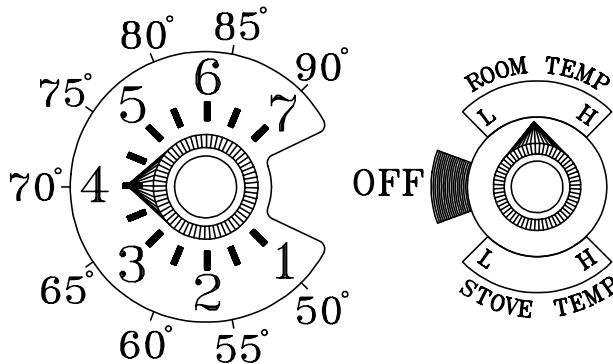
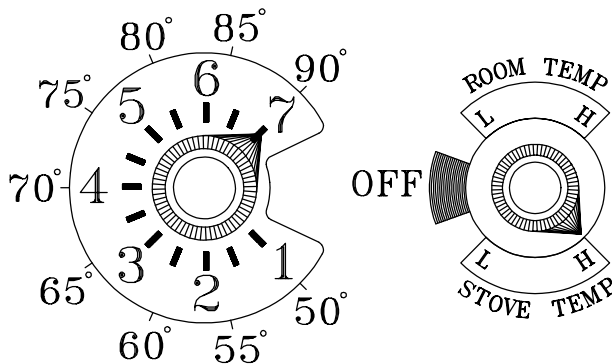

Fig. 13

*This setting will produce medium heat with the distribution blower on "low".*



*This setting will produce a room temperature of 70 degrees with the distribution blower at medium speed.*



*This setting will produce continuous maximum heat output with the distribution blower at full speed.*

## When to use "Stove Temp Mode"

In "Stove Temp Mode" the Stove Temp Dial determines the temperature of the stove. Heat output and fuel consumption will remain constant. This makes it possible to tell how long a hopper full of pellets will last. The distribution blower speed will vary according to the position of the mode selector, fig. 13.

## When to use "Room Temp Mode"

In "Room Temp Mode" heat output is controlled automatically by the Room Sensing Probe. When the Room Sensing Probe calls for heat, the stove will increase output. When the Room Sensing Probe is getting close to the set temperature, the stove will begin to level off output and keep the fire burning at just the right temperature to maintain that setting.

High output is determined by the feed rate. The maximum feed rate should be set for 1" of ash in front of fire.

In "Room Temp Mode" fuel consumption is sacrificed for exact room temperature. Therefore, as it gets colder more pellets will be burned automatically.

The distribution blower speed will vary according to the position of the mode selector, fig. 13.

## Shut-Down Procedure

To kill the fire or stop burning the stove, Turn the Mode Selector to "OFF". This will cause the fire to diminish and burn out. When the fire burns out and the stove cools down everything will stop.

If you pull the plug to shut down the stove, all motors will stop. This may cause incomplete combustion and smoke in the firebox. If the load door is opened the smoke may escape.

The best way to shut down the stove is simply let it run out of pellets, then the stove will shut down automatically.

# ESP CONTROL

## Power Light

Indicates power to the control.

### Secondary

*function:* Blinks every 15 seconds when the feed adjuster is in "Test Mode". This verifies feeder switch operation.

## Status Light

Blinks to Indicate errors listed below.

Indicates Power to distribution blower.

Indicates Power to combustion blower.

Indicates Power to the feed motor.

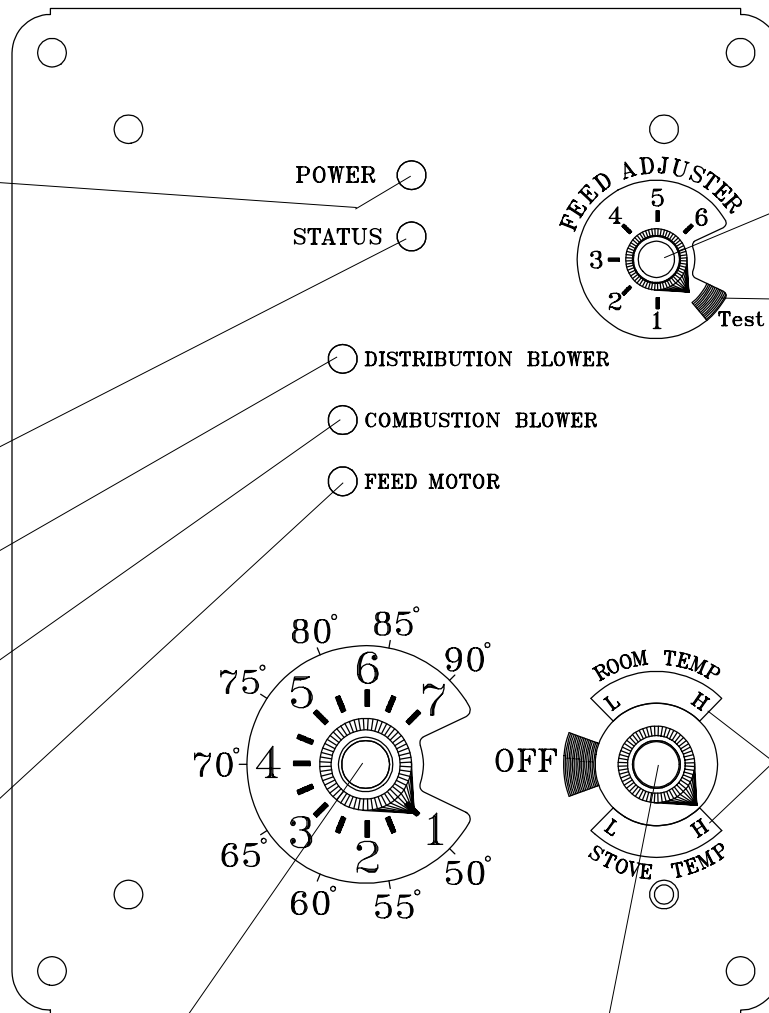

## Feed adjuster

Sets the maximum feed rate

## Test

Runs all motors at full speed for two minutes to check operation. After two minutes the stove will go to minimum burn and the blowers will alternate from high to low every two minutes to remind you that you are still in "Test Mode".

## Temp dial

Allows you to adjust the Room temperature in Room Temp Mode using the outer scale marked in degrees Fahrenheit. It also allows you to adjust the stove temperature while in Stove Temp Mode using the inner scale marked from 1 to 7.

## Mode Selector

Allows you to choose between Room Temp Mode, Stove Temp Mode, or OFF. Also allows you to vary the distribution blower speed by turning the knob to the high or low side of each mode.

Distribution Blower speed adjustment range.

## Status light error messages:

**1 Blink:** Indicates control board self diagnostic failure. This requires a manual reset\*.

**2 Blinks:** Indicates that the feeder position switch has not sensed the slide plate in the home position for 30 minutes. This means that the slide plate may be stuck do to a foreign object in the fuel or the switch has failed. If the switch has failed the stove will operate normally, however if turned to the "OFF " position the stove will go to minimum burn and will only shut down when it runs out of fuel. If the slide plate frees its self the status light will

automatically reset. If the error continues call your Harman Dealer.

**3 Blinks:** Indicates ESP (Exhaust Sensing Probe) failure. This requires a manual reset\*.

**4 Blinks:** Can occur only in Room Temp Mode and indicates Room Sensing Probe failed or not installed. If a Room Sensing Probe is then installed the status light will automatically reset.

\* **Manual reset**, disconnect power cord for a few seconds and reconnect. If error still occurs call your Dealer.