

**Model:**  
FUZION-EX

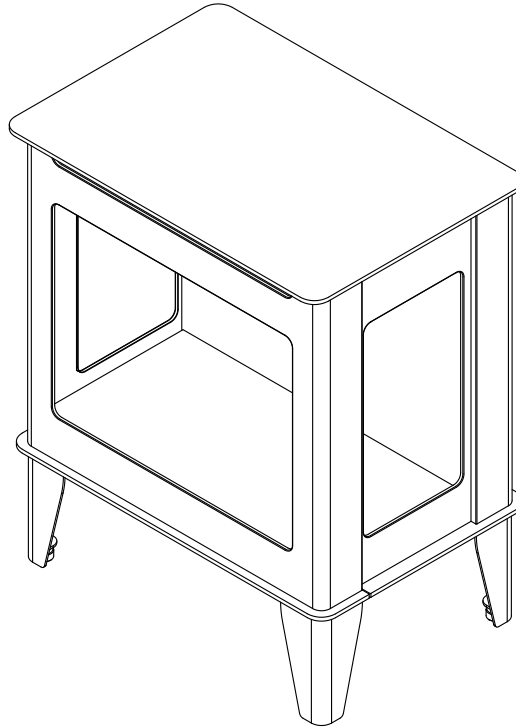

**NOTICE**



**DO NOT DISCARD THIS MANUAL**

- Important operating and maintenance instructions included.
- Read, understand and follow these instructions for safe installation and operation.
- Leave this manual with party responsible for use and operation.



Congratulations on your choice of the FUZION by Forge & Flame electric freestanding stove, this stove is designed to provide you with a year-round flame appearance that provides the utmost in safety, reliability and efficiency.

**READ CAREFULLY BEFORE ATTEMPTING TO ASSEMBLE, INSTALL, OPERATE, OR MAINTAIN THIS PRODUCT.**

**PROTECT YOURSELF AND OTHERS BY OBSERVING ALL SAFETY INFORMATION. FAILURE TO COMPLY WITH INSTRUCTIONS COULD RESULT IN PERSONAL INJURY AND/OR PROPERTY DAMAGE.**

**⚠ WARNING: To reduce risk of fire, electrical shock, or personal injury, read all instructions before using appliance.**

**INSTALLER: DO NOT DISCARD THIS MANUAL -  
LEAVE FOR HOMEOWNER - SAVE THESE INSTRUCTIONS**

# 1 Important Safety Information

## IMPORTANT SAFETY INSTRUCTIONS

**WARNING**



**WARNING! Risk of Fire! Risk of Burns!  
Risk of Electrical Shock!**

**DO NOT:**

- Install or operate damaged heater
- Modify heater
- Operate the heater without fully assembling all components



*Hearth & Home Technologies Inc. disclaims any responsibility for, and the warranty and agency listing will be voided by the below actions.*

When using electrical appliances, basic precautions should always be followed to reduce the risk of fire, electric shock, and injury to persons, including the following:

- Read all instructions before installing this appliance.
- This appliance is hot when in use. To avoid burns, do not let bare skin touch hot surfaces. Keep combustible materials such as furniture, pillows, bedding, papers, clothes, etc., and curtains at least 3 ft. (0.9 m) from the front of the appliance and keep them away from the sides and rear.
- Extreme caution is necessary when any appliance is used by or near children or other at risk individuals and whenever the appliance is left operating and unattended.
- Do not operate any appliance if it malfunctions. Disconnect power at service panel and have appliance inspected by a certified electrician before reusing.
- To prevent a possible fire, do not block appliance fan air intakes or exhaust in any manner.
- A heater has hot and sparking parts inside. Do not use it in areas where gasoline, paint, or flammable vapors or liquids are used or stored.
- Use this appliance only as described in this manual. Any other use not recommended by the manufacturer may cause fire, electric shock, or injury to persons.
- Do not operate any appliance with a damaged cord or plug or after the appliance malfunctions, has been dropped or damaged in any manner. Contact authorized dealer.
- Do not use outdoors.
- Never locate appliance where it may fall into a bathtub or water container.
- Do not run cord under carpeting. Do not cover cord with throw rugs, runners, or the like. Arrange cord away from traffic areas and where it will not be tripped over. Do not tightly coil cord.

**WARNING**

**DO NOT OPERATE APPLIANCE BEFORE READING AND UNDERSTANDING OPERATING INSTRUCTIONS. Failure to operate appliance according to operating instructions could cause fire or injury.**

**WARNING**

**IMPROPER INSTALLATION, ADJUSTMENT, ALTERATION, SERVICE OR MAINTENANCE CAN CAUSE INJURY OR PROPERTY DAMAGE. Failure to install appliance according to Owner's Manual could cause property damage or injury.**

**NOTICE!** *This appliance is not intended for use as a primary heat source and should not be factored as such in residential heating calculations.*

- Always use ground fault protection where required by electrical code.
- To disconnect appliance, turn controls to "OFF" then remove plug from outlet.
- Always disconnect power before performing any cleaning, maintenance or relocation of the appliance.
- To prevent electrical shock or fire, always use a certified electrician should new circuits be required.
- When transporting or storing the appliance, keep in a dry place free from excess vibration to avoid damage.
- Avoid use of an extension cord because an extension cord may overheat and cause a fire. However if you have to use an extension cord, the cord should be No. 14 AWG minimum size and rated to not less than 1875 watts.
- This appliance is not intended for use by persons (including children) with reduced physical, sensory or mental capabilities, or lack of experience and knowledge, unless they have been given supervision or instruction concerning use of the appliance by a person responsible for their safety.
- Children should be supervised to ensure that they do not play with the appliance.
- Do not insert or allow fingers or foreign objects to enter any ventilation or exhaust opening as it may cause an electric shock or fire or damage the heater. Do not block or tamper with the heater in any manner while it is in operation
- Always use properly grounded, fused and polarized outlets.

**⚠ Safety Alert Key:**

- **WARNING!** Indicates a hazardous situation which, if not avoided could result in death or serious injury.
- **CAUTION!** Indicates a hazardous situation which, if not avoided, could result in minor or moderate injury.

## Table of Contents

Congratulations! ..... 1

**1 IMPORTANT INSTRUCTIONS**

A. Warranty..... 4

**2 GENERAL INFORMATION**

A. Appliance Certification..... 6

B. Unpacking and Inspecting Appliance ..... 6

C. Model and Serial Number Information ..... 6

**3 GETTING STARTED**

A. Parts and Hardware ..... 7

B. Appliance Dimensions..... 7

C. Tools and Supplies Needed ..... 7

D. Location ..... 8

E. Clearance to Combustibles ..... 8

F. Electrical Connection ..... 8

**4 INSTALLATION**

A. Selecting Appliance Location ..... 9

B. Appliance Preparation ..... 9

C. Set-Up Appliance ..... 9

    Leg and Anti-Tip Bracket Attachment ..... 10

    Installing Side Panel Covers..... 11

**5 OPERATING INSTRUCTIONS**

A. Manual Switch Function ..... 12

B. Heat Disengagement Switch..... 12

C. Operating by Remote Control ..... 13

D. Resetting Temperature Cutoff Switch ..... 13

E. Room Temperature and Thermostat Function ..... 13

**6 MAINTENANCE**

A. Maintenance ..... 15

B. Cleaning ..... 15

C. Servicing ..... 15

D. Troubleshooting Guide..... 16

E. Service Parts List ..... 18

F. Contact Information ..... 20

➔ = Contains updated information

## A. Warranty

### Hearth & Home Technologies LLC LIMITED WARRANTY

Hearth & Home Technologies LLC (“HHT”) extends the following warranty for HHT gas, wood, pellet and electric hearth appliances (each a “Product” and collectively, the “Product(s)”) and certain component parts set forth in the table below (“Component Part(s)”) that are purchased from a HHT authorized dealer or distributor.

#### **WARRANTY COVERAGE:**

HHT warrants that the Products and their Component Parts will be free from defects in materials and workmanship for the applicable period of Warranty coverage set forth in the table below (“Warranty Period”). If a Product or Component Parts are found to be defective in materials or workmanship during the applicable Warranty Period, HHT will, at our discretion, repair the applicable Component Part(s), replace the applicable Component Part(s), or refund the purchase price of the applicable Product(s). The maximum amount recoverable under this Warranty is limited to the purchase price of the Product. This Warranty is transferable from the original purchaser to subsequent owners, but the Warranty Period will not be extended in duration or expanded in coverage for any such transfer. This Warranty is subject to conditions, exclusions, and limitations as described below.

#### **WARRANTY PERIOD:**

Warranty coverage begins at the date of installation. In the case of new home constructions, Warranty coverage begins six months after invoice of the final sale of the Product(s) by an independent, authorized HHT dealer or distributor. However, the Warranty coverage shall commence no later than 24 months following the date of Product shipment from HHT, regardless of the installation or purchase date.

Warranty Period		HHT Manufactured Appliances and Venting					
Component Parts	Labor	Gas	Pellet	Wood	Electric	Component Parts Covered by this Warranty	
1 Year		X	X	X		All parts including handles, external enameled components and other material except as covered by Warranty Conditions, Warranty Exclusions, and Warranty Limitations listed	
2 Years					X	All parts except as covered by Warranty Conditions, Warranty Exclusions, and Warranty Limitations listed	
			X	X		Glass, Electrical components limited to heating element/igniters, Top feed auger assembly, Blowers, Junction Box, Remotes/Wall switches, linear actuator, power cord, vacuum switch, snap disc, wire harnesses and thermocouple	
		X				Electrical components limited to modules, remotes/wall switches, valves, pilots, blowers, junction boxes, wire harnesses, transformers and lights (excluding light bulbs)	
		X		X		Cement Refractory Panels, Glass Liner Panels	
3 years			X			Firepots, burnpots, Harman mechanical feeders	
5 years		X		X		Catalysts, Vented and Vent Free burners and logs	
10 years	1 year	X				Burners, logs and metal/fiber refractory components of HHT manufactured fireplaces or stoves, venting due to poor workmanship	
10 years	3 years		X	X		Castings, Medallions & Baffles, FlexBurn® System (engine, inner cover, access cover and fireback), Firebox and heat exchanger, HHT Chimney & Terminations, Manifolds	
20 years	3 years	X				Firebox and heat exchanger	
<b>All purchased replacement parts and optional accessories</b>							
1 Year	None	X	X	X	X	All purchased replacement parts and optional accessories	

## **WARRANTY CONDITIONS:**

- Because HHT cannot control the quality of any Products sold by unauthorized sellers, this Warranty only covers Products that are purchased through an HHT authorized dealer or distributor unless otherwise prohibited by law; a list of HHT authorized dealers is available on the HHT branded websites.
- This Warranty is only valid while the applicable Product remains at the site of original installation.
- This Warranty is only valid in the country in which the HHT authorized dealer or distributor that sold the applicable Product is authorized to sell applicable Product.
- Contact your installing distributor or dealer for Warranty service. If the installing dealer or distributor is unable to provide necessary parts, contact the nearest HHT authorized dealer or supplier. Additional service fees may apply if you are seeking Warranty service from a dealer other than the dealer from whom you originally purchased the applicable Product.
- No HHT consumer should bear cost of warranty service or costs incurred while servicing warranty claims (i.e., travel, gas, or mileage) when the service is performed within the terms of this Warranty. Check with your dealer or distributor in advance for any costs to you when arranging a warranty call. Travel and shipping charges for parts are not covered by this Warranty.

## **WARRANTY EXCLUSIONS:**

This Warranty does not cover the following:

- Changes in surface finishes as a result of normal use. As a heating appliance, some changes in color of interior and exterior surface finishes may occur. This is not a flaw and is not covered under the Warranty.
- Damage to printed, plated, or enameled surfaces caused by fingerprints, accidents, misuse, scratches, melted items or other external sources and residues left on the plated surfaces from the use of abrasive cleaners or polishes.
- Repair or replacement of parts that are subject to normal wear and tear during the Warranty Period are not covered. These parts include: paint, wood and pellet gaskets, firebricks, wood grates, flame guides, batteries and the discoloration of glass.
- Minor expansion, contraction, or movement of certain parts causing noise. These conditions are normal and complaints related to this noise are not covered by this Warranty.
- Damages resulting from: (1) failure to install, operate, or maintain the applicable Product in accordance with the installation instructions, operating instructions, and listing agent identification label furnished with the applicable Product; (2) failure to install the applicable Product in accordance with local building codes; (3) shipping or improper handling; (4) improper operation, abuse, misuse, continued operation with damaged, corroded or failed components, accident, or improperly/incorrectly performed repairs; (5) environmental conditions, inadequate ventilation, negative pressure, or drafting caused by tightly sealed constructions, insufficient make-up air supply, or handling devices such as exhaust fans or forced air furnaces or other such causes; (6) use of fuels other than those specified in the operation instructions; (7) installation or use of components not supplied with the applicable Product or any other components not expressly authorized and approved by HHT; (8) modification of the appliance not expressly authorized and approved by HHT in writing; and/or (9) interruptions or fluctuations of electrical power supply to the applicable Product.
- Non-HHT venting components, hearth connections or other accessories used in conjunction with the applicable Product.
- Any part of a pre-existing fireplace system in which an insert or a decorative gas applicable Product is installed.
- HHT's obligation under this Warranty does not extend to the Product's capability to heat the desired space. Information is provided to assist the consumer and the dealer in selecting the proper Product for the application. Consideration must be given to the Product location and configuration, environmental conditions, insulation and air tightness of the structure.

### **This warranty is void if:**

- The applicable Product has been over-fired, operated in atmospheres contaminated by chlorine, fluorine, or other damaging chemicals. Over-firing can be identified by, but not limited to, warped plates or tubes, deformation/warping of interior cast iron structure or components, rust colored cast iron, bubbling, cracking and discoloration of steel or enamel finishes.
- The applicable Product is subjected to prolonged periods of dampness or condensation.
- There is any damage to the applicable Product due to water or weather damage which is the result of, but not limited to, improper chimney or venting installation.

## **LIMITATIONS OF REMEDIES AND LIABILITY:**

- **EXCEPT TO THE EXTENT PROVIDED BY LAW, HHT MAKES NO EXPRESS WARRANTIES OTHER THAN THE WARRANTY SPECIFIED HEREIN. The owner's exclusive remedy and HHT's sole obligation under this Warranty or in contract, tort or otherwise, shall be limited to, at HHT's sole option, replacement of the Component Part(s), repair of the Component Part(s), or refund of the original purchase price of the applicable Product(s). In no event will HHT be liable for any incidental or consequential damages caused by defects in the applicable Product. Some States do not allow the exclusion or limitation of incidental or consequential damages, so the above limitation or exclusion may not apply to you. This Warranty gives you specific legal rights and you may also have other rights which vary from State to State. THE DURATION OF ANY IMPLIED WARRANTY IS LIMITED TO DURATION OF THE EXPRESSED WARRANTY SPECIFIED ABOVE FOR THE APPLICABLE PRODUCT. Some States do not allow limitations on how long an implied warranty lasts, so the above limitation may not apply to you.**

# 2 General Information

## A. Appliance Certification

**MODELS:** FUZION-EX

**LABORATORY:** CSA International

**TYPE:** Electric Air-Heaters; Fixed and Location-Dedicated Electric Room Heaters

**STANDARDS:** CSA C22.2 No 46-13; UL 2021 (4<sup>th</sup> Edition)

**NOTICE:** This appliance must be electrically wired and grounded in accordance with local codes or, in the absence of local codes, with National Electric Code ANSI/NFPA 70-latest edition or the Canadian Electric Code CSA C22.1.

**NOT INTENDED FOR USE AS A PRIMARY HEAT SOURCE.** This appliance is tested and approved as either supplemental room heat or as a decorative appliance. It should not be factored as primary heat in residential heating calculations.

**Note:** The device complies with Part 15 of the FCC Rules. Operation is subject to the following two conditions:

1. This device may not cause harmful interference.
2. This device must accept any interference received, including interference that may cause undesired operation.



### WARNING

This product can expose you to Di-(2-ethylhexyl) phthalate, which is known to the State of California to cause cancer and reproductive harm. For more information go to: [www.P65Warnings.ca.gov](http://www.P65Warnings.ca.gov).

## B. Unpacking and Inspecting Appliance

**WARNING! DO NOT use this Electric Appliance if any part has been wet.** Immediately call a qualified service technician to inspect and to replace any part of the electrical system if necessary. Keep plastic wrapping away from children.

- Carefully remove the appliance and components from the packaging. Discard packaging.
- Carefully inspect components for any damage.
- Reference parts and hardware list to verify all parts have been received.
- Report to your dealer any missing or damaged parts.
- Read all the instructions before starting the installation. Follow these instructions carefully during the installation to ensure maximum safety and benefit.

## C. Model and Serial Number Information

The model and serial number information is located on the rating plate. The rating plate is located on the upper wall of the fireplace behind glass front.

### ELECTRIC FIREPLACE

MODEL	FUZION-EX
VOLTAGE	120V AC
FREQUENCY	60 Hz
AMPERAGE	12.5 A
WATTS	1500 W
SERIAL No.:	_____



Hearth & Home Technologies

MADE IN CHINA

## Homeowner Reference Information

*We recommend that you record the following pertinent information about your appliance.*

Model Name: \_\_\_\_\_ Date purchased/installed: \_\_\_\_\_

Serial Number: \_\_\_\_\_ Location on appliance: \_\_\_\_\_

Dealership purchased from: \_\_\_\_\_ Dealer Phone: \_\_\_\_\_

Notes: \_\_\_\_\_

# 3 Getting Started

## A. Parts and Hardware

Parts and Hardware List		
Part	Box	Quantity
Appliance		1
Instruction Manual		1
Logs	Box 3	16
Remote Control	Box 2	1
AAA Battery (Alkaline)		2
Legs		4
Leg Screws, M5		8
Anti-Tip Bracket		1
Anchor		1
M5 Wood Screw, #2 Phillips		1
Black Embers		1 Bag
Clear Crystal		1 Bag
Power Cord		1; 7.8ft. [2.37m]
Power Cord Retainer		1
Side Panels	Box 1	2

## B. Appliance Dimensions

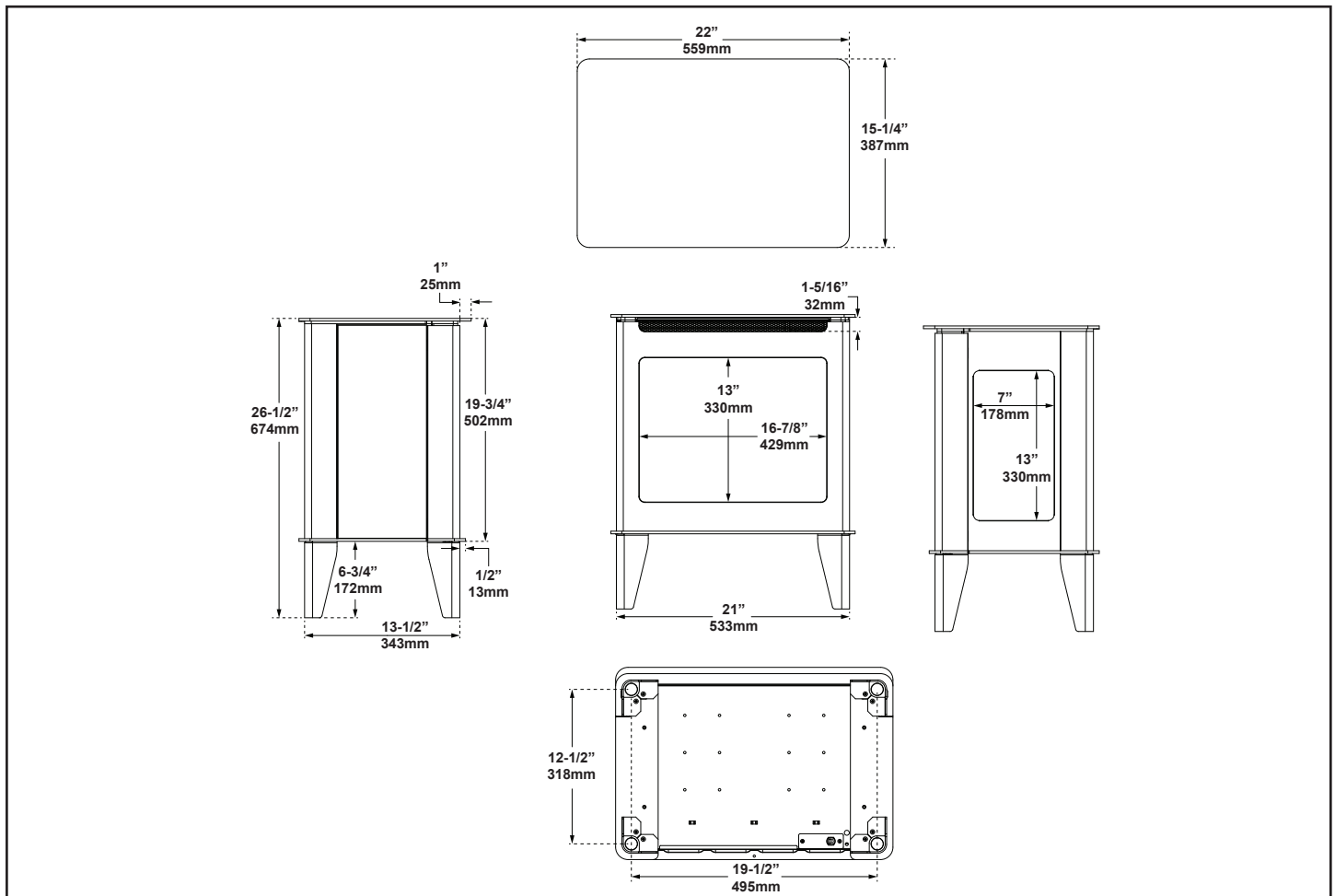

Figure 3.1 - Appliance Dimensions

## C. Tools and Supplies Needed

Before beginning the installation be sure that the following tools and building supplies are available:

- Gloves
- Phillips screwdriver
- Power Drill with
  - 3/32 [2mm] or
  - 5/16 [8mm] Drill for Masonry and Ceramic flooring applications

## D. Location

**Note:** If this appliance is installed in a bathroom, it must be protected by GFI receptacle or circuit. If receptacle is used it must be readily accessible. This electrical appliance is not water tight. To prevent electrical shock, it must be installed as to prevent water from entering appliance. It must be installed away from showers, tubs, or other water sources. Never locate the appliance where it may fall into a bathtub or other water container.

When choosing a location for your appliance ensure that the general rules are followed:

- For best results, install out of direct sunlight.
- Power supply service must be installed within proximity of electric appliance prior to finishing to avoid reconstruction.
- See Figure 3.1 for appliance dimensions and to determine location of appliance installation.
- Account for the location of the Anti-Tip Bracket. See Figure 4.5

## E. Clearance to Combustibles

Reference Figure 3.3 for minimum alcove and combustible mantle clearances.

### Minimum Clearance to Combustibles:

Sides.....0 in  
 Floor.....0 in  
 Top.....1 in  
 Back.....1 in  
 Front.....36 in (813 mm)  
 Mantels.....See Figure 3.3

**NOTE:** Do not pack insulation around the appliance blocking louvers.

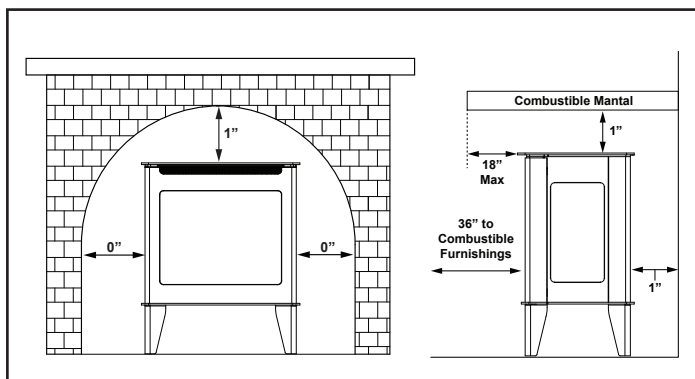



Figure 3.3 - Alcove and Combustible Mantle Clearances

**WARNING**

**Risk of Fire!** Keep electrical cords, drapery, furnishings or other combustibles at least 3 ft. (0.9 m) from the front of the electric appliance.

## F. Electrical Connection

**WARNING**

**Risk of Fire, Electrical Shock and Injury!** Electrical wiring must comply with local building codes and other applicable regulations to reduce the risk of fire, electrical shock and injury.

A minimum 15 AMP, 120 Volt, 60 Hz circuit with a properly grounded outlet is required.

The appliance is supplied with a power cord equipped with NEMA-5-15P plug. An adapter must be used for connecting to a two-slot receptacle (Figure 3.4). The green grounding wire extending from the adapter must be connected to a permanent ground such as a properly grounded outlet box. The adapter should not be used if a three slot grounded receptacle is available.

### Electrical Outlet Box

**Note:** Power cord is approximately 7.8 feet (2.37 m) long, and is connected to the right rear bottom of the appliance. See Figure 3.5

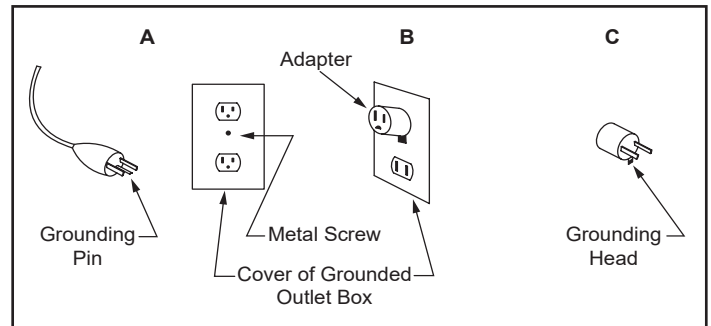



Figure 3.4 - Cord Electrical Connection

**WARNING**

**RISK OF FIRE, ELECTRICAL SHOCK AND INJURY!** Ensure the power cord is not installed so that it is pinched or against a sharp edge and ensure that the power cord is stored or secure to avoid tripping and snagging.

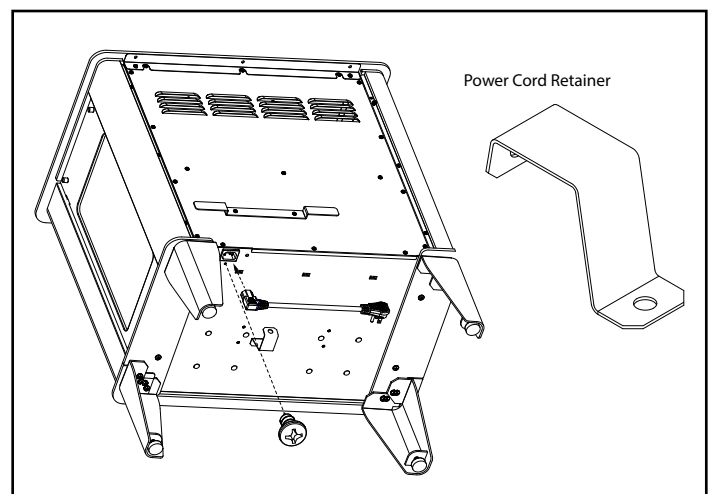

Figure 3.5 - Power Cord Installation



# 4 Installation

## A. Selecting Appliance Location

When selecting a location for the appliance it is important to consider the required clearances to walls. See Figure 4.10 and 4.11.



### WARNING

**RISK OF FIRE OR BURNS!** Provide adequate clearance around air openings and for service access. **Due to high temperatures, the appliance should be located out of traffic and away from furniture and draperies.**

**NOTICE:** Illustrations reflect typical installations and are FOR DESIGN PURPOSES ONLY. Illustrations/diagrams are not drawn to scale. Actual installation may vary due to individual design preference.

## B. Appliance Preparation

1. Remove front from packaging and carefully place back side down, glass side up on a non-marking surface.

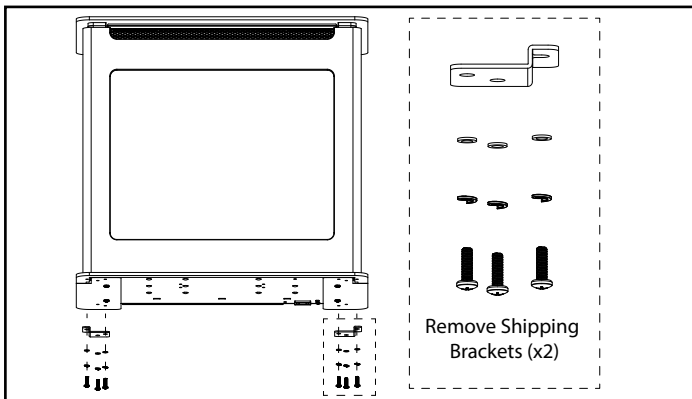

Figure 4.1 - Detaching Front

### NOTICE



**TWO** people are recommended for the installation of FUZION-EX. Remove all packaging materials. Protective films and tapes before turning on the appliance.

### Remove the Front

2. The Front is shipped attached to the appliance. To remove the front, remove the screws from the shipping brackets on the bottom of the appliance, Figure 4.1.
3. Grasp the Front and lift up to disengage the J-hooks and pull the front away from the appliance. Place the front down on a non-marking surface, Figure 4.2.
4. Remove the top glass bracket by removing three (3) Phillips screws. Lift the glass from the bottom channel. Retain and re-use the top and bottom rubber channel, Figure 4.3.

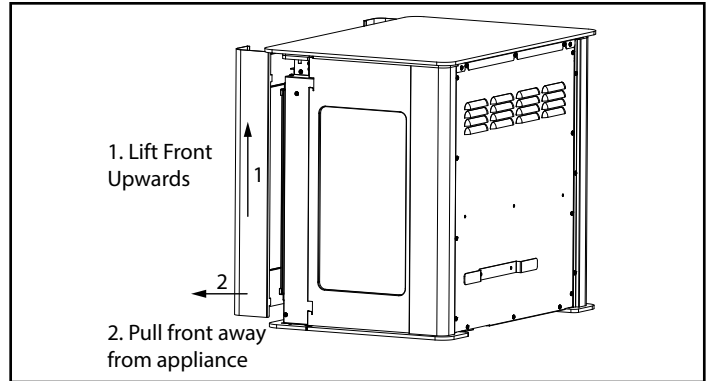

Figure 4.2 - Front Removal

## C. Set-Up Appliance

1. Remove component boxes, packaging materials and protective film on the glass.
2. Remove legs and hardware from Box 1 and install using the provided hardware as shown in Figure 4.4.
3. Use two people to carefully lift and place the appliance on its legs, adjust leveling bolts as required.
4. Install the anti-tip bracket on one of the four appliance legs as shown in figure 4.4.
  - Position the Anti-Tip Bracket and mark the location of the hole onto the flooring.
  - Use a 3/32 or 2mm Drill Bit to pre-drill a 2in[50mm] hole at the marked location.
  - **For installation onto ceramic or masonry flooring,** use an appropriate 5/16 or 8mm drill bit for the material, to drill a 2 in. [50mm] deep hole. Insert the provided 8 x 40mm plastic anchor into the hole for securing the anti-tip bracket. See Figure 4.5.
  - Use the provided M5 woodscrew to secure the bracket into flooring.
5. Place media and logs in ember bed as desired.
6. Reattach glass and front.

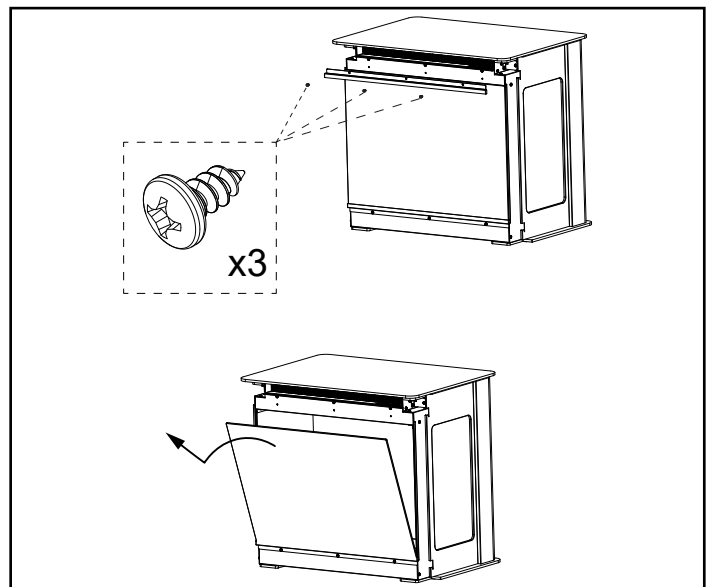

Figure 4.3 - Glass Removal

## Leg and Anti-Tip Bracket Attachment

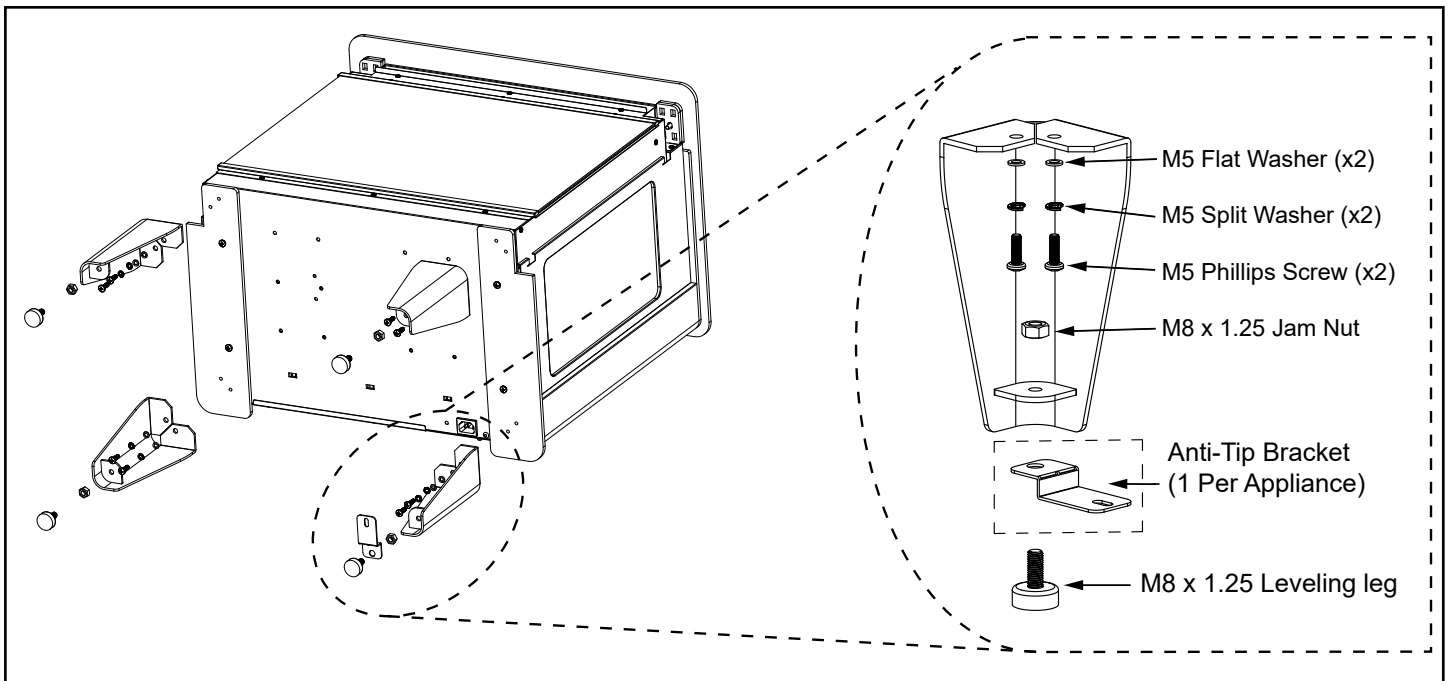

Figure 4.4 - Leg and Anti-Tip Bracket Attachment

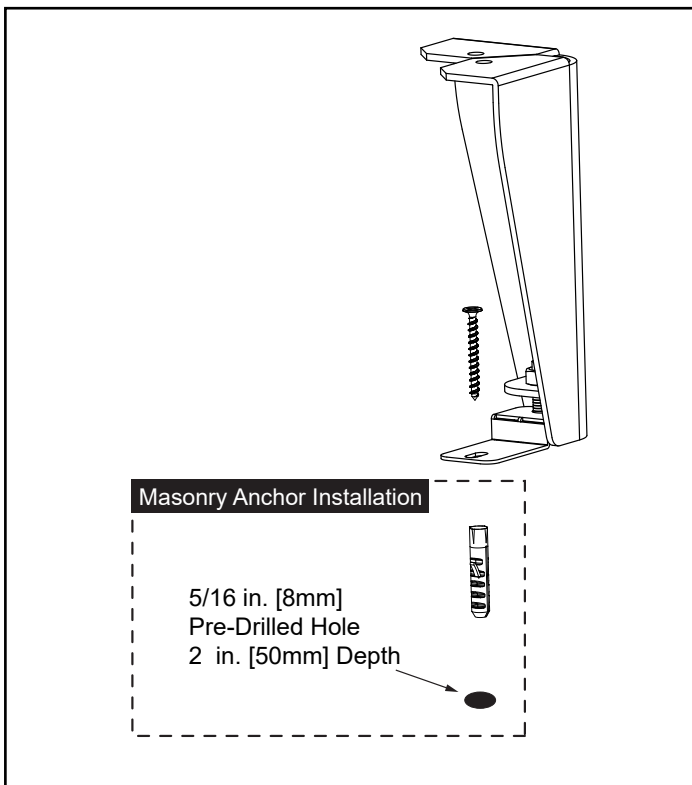
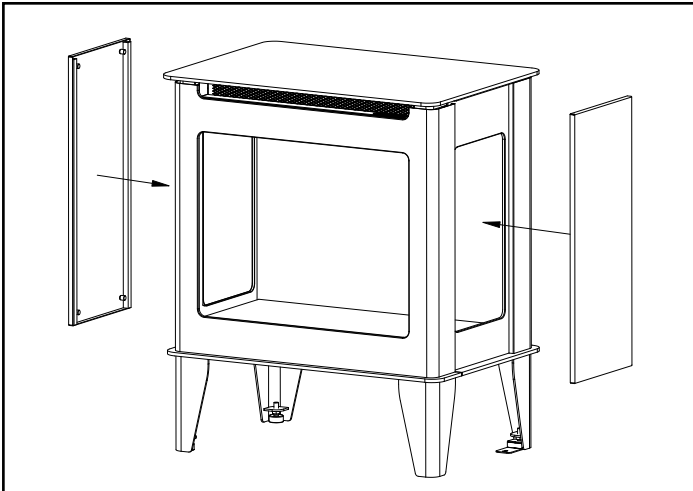

Figure 4.5 - Securing Anti-Tip Bracket

### Installing Side Panel Covers (Optional)

This appliance is designed to be set up to show either three sides of glass or one side of glass. To show only one side of glass follow these steps:

1. Remove side panels from component Box #1.
2. Align side panel with channels on side of appliance and attach panels. The attached magnets will hold the panels in place.
3. To remove side panels, carefully pry side panel away from appliance.



**Figure 4.6 - Side Panel Covers**

# 5 Operating Instructions



## WARNING

**DO NOT OPERATE THE APPLIANCE IF IT IS DAMAGED OR HAS MALFUNCTIONED.** If you suspect the appliance is damaged, call a qualified service technician to inspect and replace any part of the electrical system if necessary.

**Note:** A harmless slight brief odor may occur during first use or after prolonged period of storage.

### A. Manual Switch Function:

The appliance can be operated by both remote control and touch control buttons. Once the appliance has been properly connected to a grounded electrical outlet, turn on the power button located on the upper right side of the appliance. A beep should be heard when the power is first applied. See Figure 5.1.

1. **Power Button** - The Power button turns the power of the appliance on or off.
2. **Dimmer Button** - The Dimmer button adjusts the brightness of all lights simultaneously through 4 settings.
3. **Ember Button** - Pressing the Ember button changes the ember bed colors (13 solid colors, 1 rotating color theme, and off)
4. **Heater Button** - The Heater button will cycle between Low / High / Off settings.
  - Press the heater button to turn ON. The appliance will beep, illuminate one LED (see Figure 5.1), and turn the heater on LOW heat setting.

- Pressing a second time. The appliance will beep, illuminate two LEDs, and turn the heater on HIGH heat setting.
- Press a third time. The appliance will beep, no LED will illuminate, and heater will turn OFF.

**NOTE:** There is a brief delay between the heater command and the heat turning ON. When the appliance receives a heater ON command, the appliance blower will turn ON for 10 seconds before the heater turns ON. There is also an 10 second delay between heater off and blower shutdown.

5. **Flame Button** - The Flame button, cycles the appliance through four flame effects.

### B. Heat Disengagement Switch

The appliance is equipped with a heat disengagement switch. This switch disables the use of the heater and will prevent it from being turned on by the remote or manual heater button. The switch is located behind the front viewing glass and is on the ceiling inside the appliance. See Figure 5.1. Refer to Section 4 for glass removal.

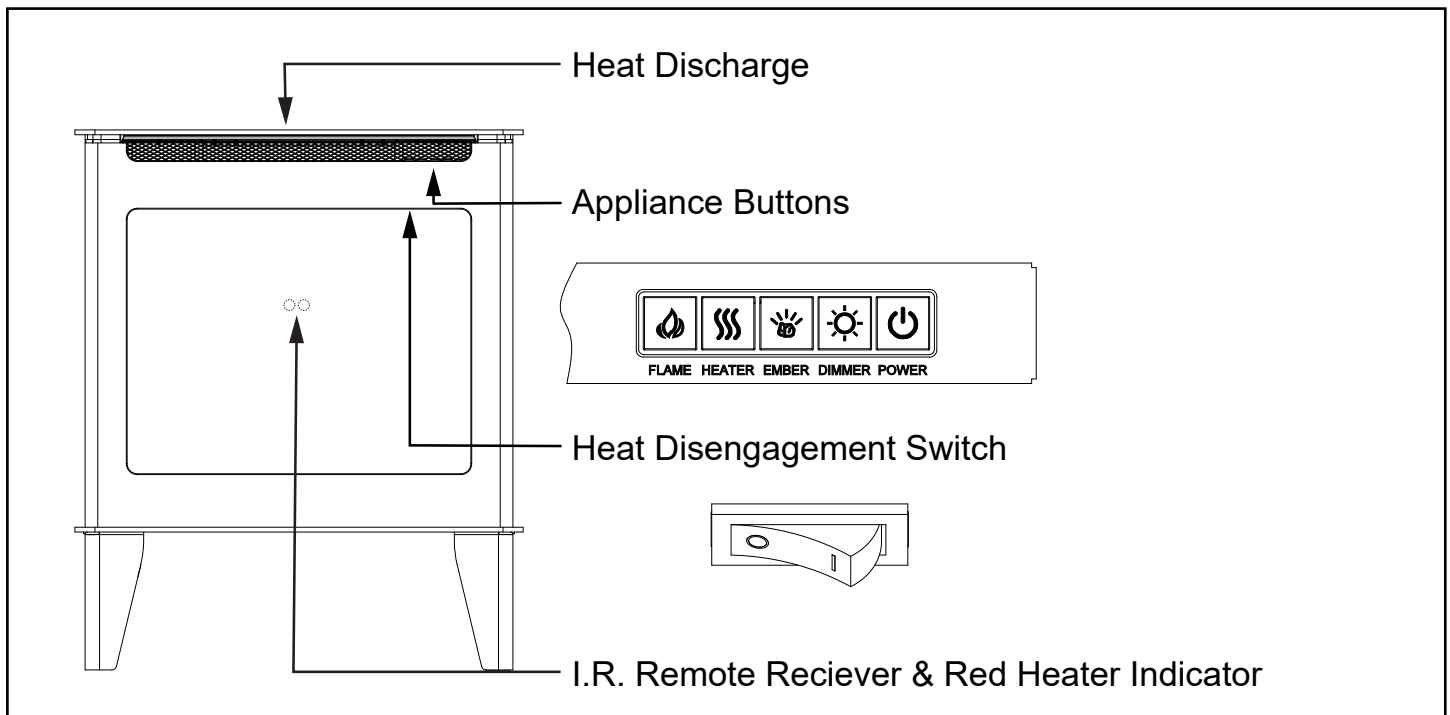

Figure 5.1 - Buttons and Heat Disengagement

### C. Operating by Remote Control

- Make sure batteries are properly installed in Remote Control.
  - Battery requirements 2 x AAA batteries (included)
- The effective range of the remote is up to 13 ft.
- The remote control must be within the 13 ft. range and also be pointed directly at the face of the center of the Flame Screen of the appliance. For best results, position the remote control within 40 degrees of the face of the appliance.

### D. Resetting Temperature Cutoff Switch

The heater is protected with a safety device to prevent overheating. Should the heater overheat, an automatic cutoff will turn the heater OFF. It will not turn ON automatically without being reset. If it overheats for any reason, it can be reset by:

1. Turn appliance to off
2. Unplug unit or turn off the breaker to the circuit supplying power to the appliance and wait 15 minutes
3. Plug in or re-supply power to the appliance circuit and turn on.



#### CAUTION

**If you need to continuously reset the heater, contact your dealer for service.**









### E. Room Temperature and Thermostat Function

The temperature display on the remote control is a set point for the desired temperature of the room in which the appliance is installed. The Thermostat button on the remote can be used to set the desired room temperature. The heater will only operate if the remote control temperature set point is higher than the actual room temperature. The heater will not operate if the actual temperature is greater than the remote control temperature set point. This function can also be used as a thermostat, under the following conditions:

- When the remote control display is set to a desired room temperature using the thermostat button, the appliance heater will turn OFF automatically when the room temperature reaches the set point.
- The heater will turn ON automatically if the room temperature falls below the set point.

**Note:** The actual room temperature is measured by a hidden sensor located on the underside of the of the appliance. During certain situations, this sensor temperature can be slightly different than either the remote control location, or the overall space being heated. For this reason, the remote control set point temperature may need to be set slightly higher or lower than expected room temperature for the heater function to work as desired.

## E. Room Temperature and Thermostat Function (Cont)

REMOTE PHOTO	ICON	TITLE	FUNCTION	REMOTE LCD DISPLAY	APPLIANCE RESPONSE
		<b>POWER</b>	The POWER button will turn the appliance on. It will also put the appliance in a standby mode. This will turn off all functions at once but will hold the settings in memory except Timer function. The appliance will turn on at the same settings by pressing the power button again.	LCD illuminates and displays flame status icon and temperature set point.	Appliance emits single audible beep to confirm command to transition to ON or STANDBY state.
		<b>FLAME</b>	By pressing the FLAME button, the appliance will cycle through four flame effects.	LCD illuminates and displays flame status icon.	Appliance emits single audible beep to confirm command to transition between four FLAME states.
		<b>HEATER</b>	Press Heater button once, heater turns on LOW. Press Heater button twice, heater turns on HIGH. Press Heater button three times, heater turns off.	LCD illuminates and displays heater status icon.	Appliance emits single audible beep to confirm command to transition between HEATER states. Appliance displays one red LED for 10 seconds to confirm low heater command. Appliance displays two red LED for ten (10) seconds to confirm high heater command.
		<b>THERMOSTAT</b>	Pressing the Temperature button adjusts the heaters response to the ambient temperature conditions in the room. Temperature adjusts from 16 °C - 28 °C (60 °F - 82 °F). To exit Thermostat mode, toggle Temperature button until no temperature is displayed. Hold Thermostat button for 3 seconds to toggle the LCD display from °C to °F. Power button must be on to set °C to °F.	Remote displays the temperature set-point. If no temperature is displayed, appliance is no longer in thermostat mode. If in Stand-by mode, temperature will display but cannot be adjusted.	Appliance emits single audible beep to confirm command to change desired temperature set point.
		<b>TIMER</b>	Pressing the Timer button sets the time desired for the appliance to run. The Timer can be set from 30 minutes and one hour increments up to nine hours.	Remote will display the time setting selected. If in Standby mode time will display but cannot be adjusted.	Appliance emits single audible beep to confirm command to change desired timer setting.
		<b>DIMMER</b>	Pressing the Dimmer button adjusts the brightness setting (4 brightness settings) of all LEDs Accent/Flame/Ember Bed simultaneously.	No indicator.	Appliance emits single audible beep to confirm command and toggles to the next brightness setting.
		<b>EMBER BED</b>	Pressing the Light button changes the ember bed colors (14 color themes available - 13 colors and a color rotating option), and turns it on/off.	No indicator.	Appliance emits single audible beep to confirm command and toggles to the next accent light color setting.
		<b>ACTIVE EMBER BED</b>	Pressing the Active Ember Bed button changes the ember bed lighting from a static state to an active state that offers additional ambiance.	No indicator.	

# 6 Maintenance

## A. Maintenance



### WARNING



**RISK OF SHOCK!** Always unplug the cord before moving or servicing. Do not immerse appliance in water.

- Always turn OFF the appliance and disconnect the cord from the electrical outlet before cleaning your appliance.
- Light accumulated dust may be removed from the appliance with a soft cloth or vacuum cleaner.
- Wipe the exterior surfaces of the appliance occasionally with a slightly damp cloth using a solution of mild detergent and water. Dry thoroughly before operating the appliance.



### CAUTION

DO NOT ALLOW WATER TO RUN INTO THE INTERIOR OF THE APPLIANCE AS THIS COULD CREATE A FIRE OR ELECTRIC SHOCK. Always disconnect electrical service before servicing appliance.

- The fan motor is factory lubricated for life and will not require further lubrication.
- Store appliance in a clean dry place when not in use.



### WARNING



**Risk of Fire!** To reduce risk of fire, do not store or use gasoline or any other flammable vapors or liquids in the vicinity of the appliance.

## B. Cleaning

### Cleaning Glass

Dust particles can be removed by buffing lightly with a clean dry cloth. Fingerprints and other marks can be cleaned with a cloth dampened with a quality household glass cleaner. The glass should be completely dried with a lint free cloth or paper towel. Do not use abrasive cleaners on glass surface. Do not spray liquids directly onto any surface.

### Metal Surface

Dust particles can be removed by buffing lightly with a clean dry cloth. A damp cloth can be used to clean painted surfaces. Do not use abrasive cleaners. Do not spray liquids directly on to any surface.

## C. Servicing

Except for installation and cleaning described in this manual, an authorized service technician should perform any other servicing.



### WARNING



**RISK OF ELECTRICAL SHOCK!** Any other servicing needed must be performed by an authorized service technician. Do not attempt to service the appliance yourself.

## D. Troubleshooting Guide

Symptom	Possible Cause	Corrective Action
Circuit breaker trips or fuse blows when appliance is turned on	Exceeding current rating of the circuit breaker or fuse, perhaps from operating other appliances on the same circuit as the appliance	Install appliance onto a dedicated 15 amp circuit.
Lights in room dim while the appliance is on	Appliance is drawing close to circuit current rating	Install appliance onto a dedicated 15 amp circuit.
Appliance will not come on when using the manual controls on the appliance	Appliance is not plugged into an electrical outlet	Ensure plug is connected to a working outlet.
	No incoming power from the electrical outlet or electrical box	Check fuse/breaker panel.
	Defect in control board (PCB)	Replace the control board (PCB).
Remote control does not work	Low/dead batteries	Replace batteries in the remote.
	Remote receiver is blocked, or remote is not pointed directly at the receiver.	Ensure receiver is not blocked. Move closer to the appliance.
	Control board (PCB) malfunction?	Replace control board (PCB).
Heater will not turn on, but flame is functioning	Remote is in thermostat mode and room temperature (temperature at appliance thermistor) is higher than the set point on the remote	Increase thermostat set point on the remote, or exit thermostat mode (press the thermostat button until no temperature set point is displayed on the remote). See "Room Temperature and Thermostat Function" section of the manual.
	Appliance has overheated and safety thermal switch has tripped	Unplug or turn off power at circuit breaker and allow it to cool for 15 minutes. Then plug in the appliance or turn power back on at circuit breaker and turn appliance back on.
	Heater disengagement switch is set to "OFF" position.	Toggle the heater disengagement switch, located on the ceiling inside of appliance to the "ON" position.
	Defective main control board	Replace control board (PCB).
	Defective heater assembly	Replace heater assembly.
Heater shuts off automatically or won't stay on	Room temperature (temperature at the appliance thermistor) is higher than the set point on the remote	Increase thermostat set point on the remote, or exit thermostat mode (press the thermostat button until no temperature set point is displayed on the remote). See Section E "Room Temperature and Thermostat Function" section of the manual.
	Appliance has overheated and safety thermal switch has tripped	Unplug or turn off power at circuit breaker and allow it to cool for 15 minutes. Then plug in the unit or turn power back on at circuit breaker and turn unit back on.
Heater emits an odor	Normal operation	It is normal for the heater to emit an odor for a brief amount of time after turning on. It is burning off dust that has accumulated on the heater.
Flame does not move at all	Flame rotisserie motor is stalled or malfunctioning	Cycle appliance on or off. If problem persists inspect rotisserie and motor for blockage or interference. If no interference, replace the control board (PCB) and rotisserie motor.
Flame shudder	Flame rotisserie contacting other internal components when spinning	Ensure rod is straight and mounted properly and is spinning freely without spindles hitting other components.
	Defective flame rotisserie motor	Replace rotisserie motor.



## Troubleshooting Guide (continued)

Symptom	Possible Cause	Corrective Action
Ember bed does not light up	Ember bed is turned off	Refer to operation section of the user manual.
	Loose wiring	Check wiring to ember bed LEDs.
	Defective control board (PCB)	Replace control board (PCB).
	Defective LED lights	Replace ember bed LED lights.
Appliance turns on by itself	Defective control board (PCB)	Replace control board (PCB).
Excessive noise with heater on	Interference with fan blade	Inspect heater assembly and fan for obstructions or interference.
	Defective blower motor	Replace heater assembly.
Grinding or rubbing noise (when heater is off)	Rotisserie hitting or rubbing against internal components	Ensure rotisserie rod is straight and mounted properly and is spinning freely without spindles hitting other components. If sound is coming from friction with the rotisserie bracket, apply grease to contact point.

## E. Service Parts List



# FUZION-EX

Beginning Manufacturing Date: Dec 2023  
Ending Manufacturing Date: Active

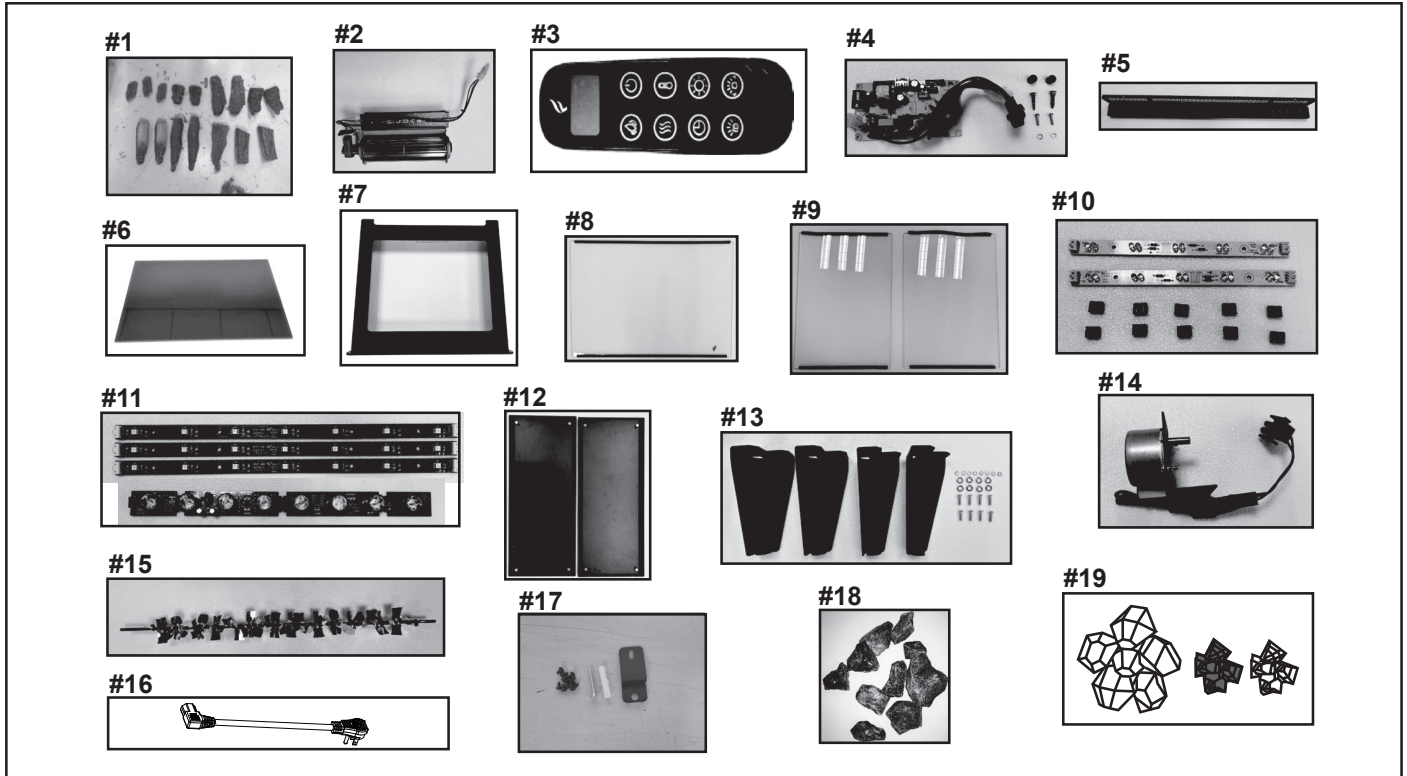

**IMPORTANT: THIS IS DATED INFORMATION.** Parts must be ordered from a dealer or distributor. **Hearth and Home Technologies does not sell directly to consumers.** Provide model number and serial number when requesting service parts from your dealer or distributor.



**Stocked at Depot**

ITEM	DESCRIPTION	COMMENTS	PART NUMBER	Stocked at Depot
1	Log Set		FZN-EX-LOGS	Y
2	Heater Assembly		FZN-EX-HEATER	Y
3	Remote Control		FZN-EX-REMOTE	Y
4	PCB		FZN-EX-PCB	Y
5	Button Controls		FZN-EX-BUTTON	Y
6	Flame Screen		FZN-EX-FLAME	Y
7	Front		FZN-EX-FRONT	Y
8	Glass		FZN-EX-GLASS	Y
9	Side Glass		FZN-EX-SDGLASS	Y
10	Spotlight LEDs		FZN-EX-DWNLED	Y
11	Flame & Ember LEDs		FZN-EX-LED	Y
12	Side Cover Panel		FZN-EX-PANELS	Y
13	Legs		FZN-EX-LEGS	Y
14	Rotisserie Motor		FZN-EX-MOTOR	Y
15	Rotisserie		FZN-EX-ROTISS	Y
16	Power Cord		FZN-EX-PLUGIN	Y
17	Hardware		FZN-EX-HDWR	Y
18	Black Embers		EMBER-SCION	Y
19	Crystal Media (Clear Small, Clear Large, & Black Small)		CRYSTAL-SCION	Y
	Remote Receiver		RECEIVER-ELECT	Y
	Black Touch-up Paint (12 oz)		3-42-19905	



