



# GLASS REFRACTORY KIT GL36MER, GL42MER

Models: MERID36IN, MERID36IL, MERID42IN, MERID42IL,  
MERIDPLA36IN, MERIDPLA36IL, MERIDPLA42IN, MERIDPLA42IL

## Installation Instructions



Leave this manual with party responsible for use and operation.

# DANGER



**HOT GLASS WILL CAUSE BURNS.**

**DO NOT TOUCH GLASS UNTIL COOLED.**

**NEVER ALLOW CHILDREN TO TOUCH GLASS.**

A barrier designed to reduce the risk of burns from the hot viewing glass is provided with this appliance and shall be installed for the protection of children and other at-risk individuals.

**CAUTION! Do not install damaged components.**

**CAUTION! Risk of Cuts or Abrasions.** Wear protective gloves and safety glasses during installation.

**NOTICE:** Handle glass refractory panels with care. Refractory may chip or crack if dropped or impacted.

### REQUIRED TOOLS

- Screw gun equipped with 1/4 in. (6 mm). socket or 1/4 in. (6 mm). wrench or socket
- Small, flat screwdriver

### KIT COMPONENTS

- (2) Side Glass Refractory Panels
- (1) Rear Glass Refractory Panel
- (1) Top Glass Refractory Panel
- (2) Side Refractory Bracket
- (1) Rear Refractory Bracket
- (1) Rear Exhaust Baffle
- (3) Screws

### Installation Instructions

1. Remove decorative front and logs.
2. Remove existing refractory or false back and discard, if installed.
3. Remove fiber refractory brackets (if so equipped) and insert screws in the holes that remain. See Figure 1.

**WARNING! Risk of Asphyxiation! DO NOT leave holes open! Screws from fiber refractory bracket removal MUST be reinstalled in same holes as removed to maintain firebox seal.**



Figure 1. Remove Fiber Refractory Brackets. Install Screw.

4. Locate the six tabs on the basepan and bend upward. They are circled in Figure 2. There are two tabs on each side and two in the back.

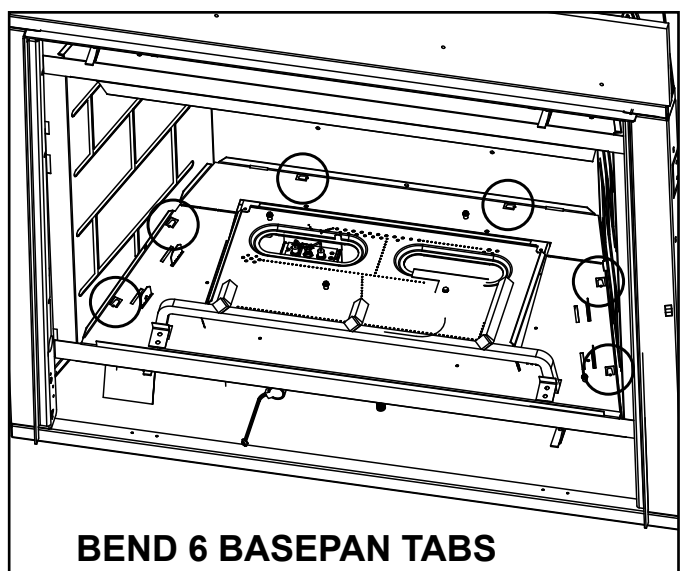

Figure 2. Basepan Tab Locations

5. Using a small, flat screwdriver, bend the ends of the refractory brackets to a 90 degree angle as shown in Figure 3. Break side refractory brackets apart by bending back and forth.

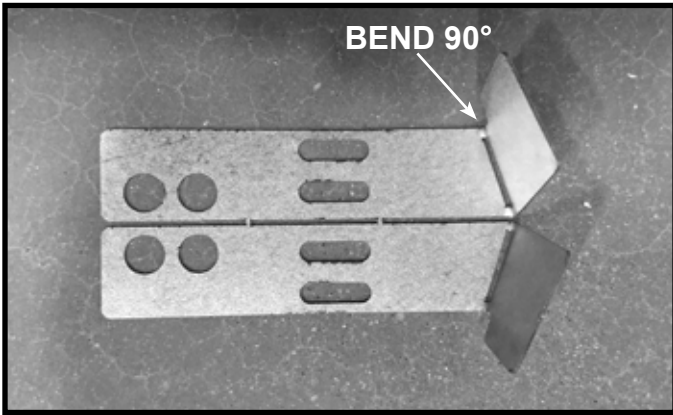

Figure 3. Glass Refractory Brackets Bent

6. **MERIDPLA Only:** Place glass brackets in position and insert screws. See Figure 4 and Figure 5 for approximate placement. Do not tighten screws at this time. They may need adjustment once glass panels are installed.

**MERID Only:** Remove one screw from the glass shield and place the retention bracket as shown in Figure 4. Reinstall the screw, but do not tighten completely at this time. Repeat this step to install retention bracket on the other side.



Figure 5. Glass Refractory Brackets Installed

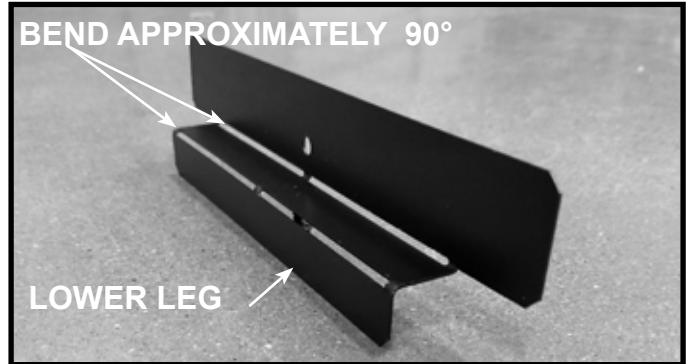

Figure 6.

7. Bend rear refractory bracket as shown in Figure 6.
8. Remove the existing rear baffle by removing two screws indicated in Figure 9.
9. Install rear glass refractory panel. The bottom of the panel is placed behind the tabs that have been bent upward. See Figure 7. Secure the back glass panel with the back refractory bracket and self-tapping screw as shown in Figure 8. Center the rear refractory bracket prior to attaching it. It may be necessary to bend the lower leg of bracket slightly more until it contacts the glass.

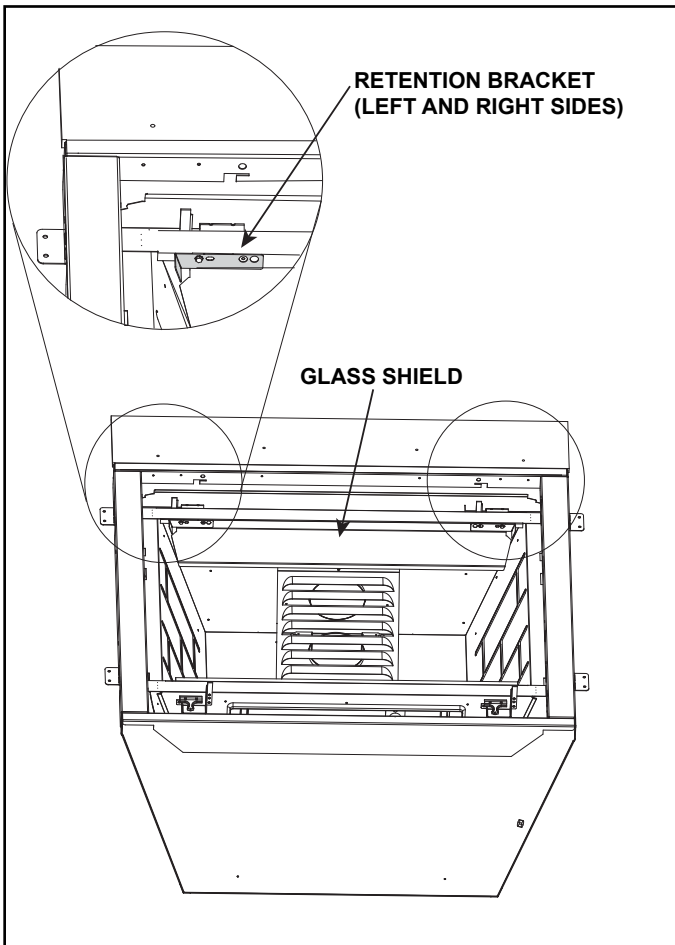

Figure 4. Retention Bracket Installed



Figure 7. Side View of Bent Tabs

10. Slide one side panel behind bent tabs until side panel is flush with rear glass panel. Slide glass refractory bracket, installed in Step 6, toward the glass and tighten the screw. Do not overtighten. Repeat process to install the other side panel. See Figure 8.

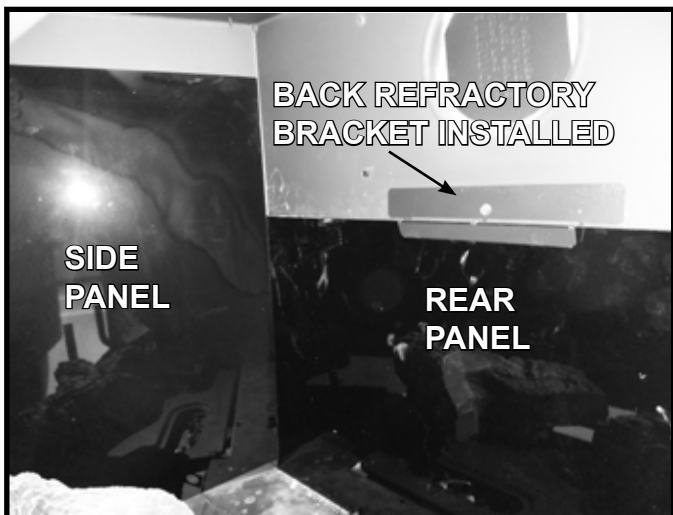

Figure 8. Side Panel Flush with Rear Panel

11. Install and secure new rear exhaust baffle with two screws as shown in Figure 9.

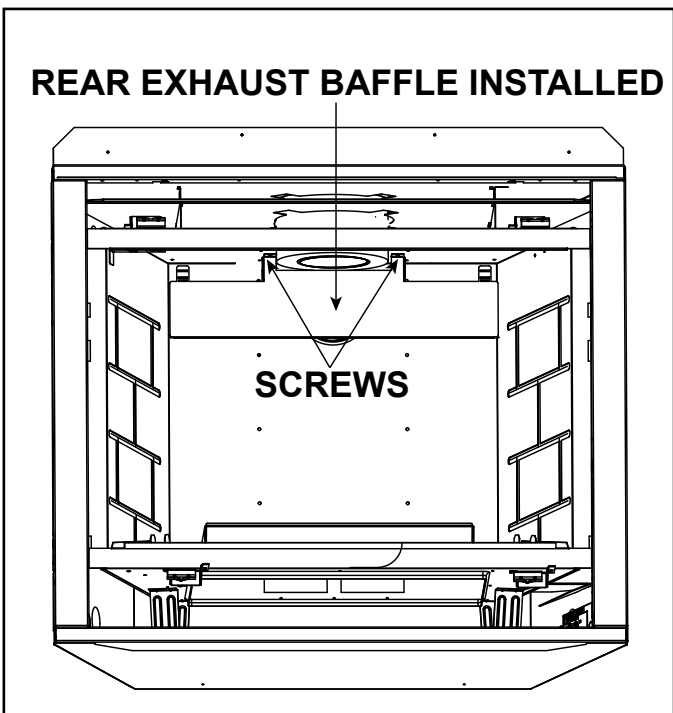

Figure 9. Rear Exhaust Baffle Installed

12. Bend the small tabs on the bottom of the rear exhaust baffle upward. See Figure 10.



Figure 10. Rear Exhaust Baffle Tabs

13. Place center glass panel on the rear exhaust baffle. The glass panel will be held in place by the bottom tabs bent up in Step 12. Bend tabs on the top over the glass panel to secure it in place. See Figure 10 and Figure 11.



Figure 11. Glass Refractory Installed

12. Reinstall logs using log placement instructions in appliance installation manual. Reinstall decorative front.

Please contact your Majestic dealer with any questions or concerns.

For the location of your nearest Majestic dealer, please visit [www.majesticproducts.com](http://www.majesticproducts.com).

Majestic, a brand of Hearth & Home Technologies  
7571 215th Street West, Lakeville, MN 55044  
[www.majesticproducts.com](http://www.majesticproducts.com)