

Model(s):  
FB-GRAND-S  
FB-IN-S

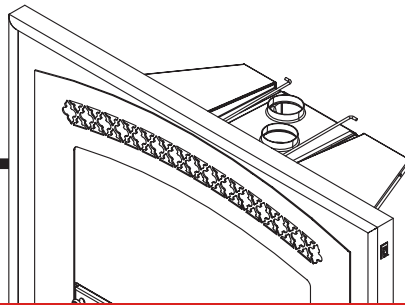

GAS-FIRED



**This appliance has been retired.  
Service parts pages within have been removed.  
For replacement parts, please refer to the individual  
service parts list located on the brand websites.**

### CAUTION



#### DO NOT DISCARD THIS MANUAL

- Important operating and maintenance instructions included.
- Read, understand and follow these instructions for safe installation and operation.
- Leave this manual with party responsible for use and operation.

DO NOT  
DISCARD

**⚠ WARNING: If the information in these instructions is not followed exactly, a fire or explosion may result causing property damage, personal injury, or death.**

- Do not store or use gasoline or other flammable vapors and liquids in the vicinity of this or any other appliance.
- **What to do if you smell gas**
  - Do not try to light any appliance
  - Do not touch any electrical switch. Do not use any phone in your building.
  - Immediately call your gas supplier from a neighbor's phone. Follow the gas supplier's instructions.
  - If you cannot reach your gas supplier, call the fire department.
- Installation and service must be performed by a qualified installer, service agency, or the gas supplier.

This appliance may be installed as an OEM installation in manufactured home (USA only) or mobile home and must be installed in accordance with the manufacturer's instructions and the manufactured home construction and safety standard, *Title 24 CFR, Part 3280 or Standard for Installation in Mobile Homes, CAN/CSA Z240MH.*

*This appliance is only for use with the type(s) of gas indicated on the rating plate.*

### ⚠ WARNING



#### HOT SURFACES!

Glass and other surfaces are hot during operation AND cool down.

#### Hot glass will cause burns.

- **DO NOT** touch glass until it is cooled
  - NEVER allow children to touch glass
  - Keep children away
  - CAREFULLY SUPERVISE children in same room as fireplace.
  - Alert children and adults to hazards of high temperatures.
- High temperatures may ignite clothing or other flammable materials.**
- Keep clothing, furniture, draperies and other flammable materials away.

***This appliance has been supplied with an integral barrier to prevent direct contact with the fixed glass panel. DO NOT operate the appliance with the barrier removed.***

Contact your dealer or Hearth & Home Technologies if the barrier is not present or help is needed to properly install one.

In the Commonwealth of Massachusetts:

- installation must be performed by a licensed plumber or gas fitter;
- a CO detector shall be installed in the room where the appliance is installed.



Installation and service of this appliance should be performed by qualified personnel. Hearth & Home Technologies suggests NFI certified or factory trained professionals, or technicians supervised by an NFI certified professional.

Read this manual before installing or operating this appliance.  
Please retain this owner's manual for future reference.

## Congratulations

Congratulations on selecting a Heat & Glo gas appliance—an elegant and clean alternative to wood burning appliances. The Heat & Glo gas appliance you have selected is designed to provide the utmost in safety, reliability, and efficiency.

As the owner of a new appliance, you'll want to read and carefully follow all of the instructions contained in this *Owner's Manual*. Pay special attention to all Cautions and Warnings.

This *Owner's Manual* should be retained for future reference. We suggest that you keep it with your other important documents and product manuals.

The information contained in this *Owner's Manual*, unless noted otherwise, applies to all models and gas control systems.

Your new Heat & Glo gas appliance will give you years of durable use and trouble-free enjoyment. Welcome to the Heat & Glo family of appliance products!

<b>Homeowner Reference Information</b>	<i>We recommend that you record the following pertinent information about your appliance.</i>
Model Name: _____	Date purchased/installed: _____
Serial Number: _____	Location on appliance: _____
Dealership purchased from: _____	Dealer Phone: _____
Notes: _____	
_____	

### Listing Label Information/Location

The model information regarding your specific appliance can be found on the rating plate usually located in the control area of the appliance.

Type of Gas

Gas and Electric Information

This product may be covered by one or more of the following patents: (Nos produits sont couverts par un ou plusieurs des brevets suivants): (United States) 4593510, 4686807, 4766876, 4793322, 4811534, 5000162, 5016609, 5076254, 5113843, 5191877, 5218953, 5263471, 5328356, 5341794, 5347983, 5429495, 5452708, 5542407, 5601073, 5613487, 5647340, 5688568, 5762062, 5775408, 5890485, 5931661, 5941237, 5947112, 5996575, 6006743, 6019099, 6048195, 6053185, 6145502, 6170481, 6237588, 6298474, 6374822, 6413079, 6439226, 6484712, 6543698, 6550687, 6601579, 6672860, 66830282, 671572482, 6729551, 6736133, 6748940, 6748942, D320652, D445174, D462436; (Canada) 1297749, 2195284, 2225408; or other U.S. and foreign patents pending (ou autres brevets américains et étrangers en attente).

**HEAT & GLO** Heat & Glo, a brand of Hearth & Home Technologies, Inc.  
No one builds a better fire 7571 215th Street West, Lakeville, MN 55044

Not for use with solid fuel.  
*(Ne doit pas être utilisé avec un combustible solide).*

Type of Gas (Sorte De Gaz): **NATURAL GAS** This appliance must be installed in accordance with local codes, if any; if not, follow ANSI Z223.1 in the USA or CAN/CGA B149 installation codes. *(Installer l'appareil selon les codes ou règlements locaux ou, en l'absence de tels règlements, selon les codes d'installation CAN/CGA-B149.)*

**ANSI Z21XX-XXXX · CSA 2.XX-MXX · UL307B**

Minimum Permissible Gas Supply for Purposes of Input Adjustment.	
Approved Minimum (De Gaz) Acceptable	0.0 in w.c. (Po. Col. d'eau)
Maximum Pressure (Pression)	0.0 in w.c. (Po. Col. d'eau)
Maximum Manifold Pressure (Pression)	0.0 in w.c. (Po. Col. d'eau)
Minimum Manifold Pressure (Pression)	0.0 in w.c. (Po. Col. d'eau)
Total Electrical Requirements: 000Vac, 00Hz., less than 00 Amperes	

**MADE IN USA**

ALTITUDE:	0-0000 FT. 0000-0000FT.	IN CANADA
MAX. INPUT BTUH:	00,000 00,000	
MIN. INPUT BTUH:	00,000 00,000	
ORIFICE SIZE:	#XXXXX #XXXXX	

Model: **XXXXXXXX**  
Serial: **XXXXXXXX**

Model Number

Serial Number

# Table of Contents

## 1 Listing and Code Approvals

A. Appliance Certification . . . . .	4
B. BTU Specifications . . . . .	4
C. High Altitude Installations . . . . .	4
D. Non-Combustible Materials Specification . . . . .	4
E. Combustible Materials Specification . . . . .	4
F. Electrical Codes . . . . .	4

## 2 Getting Started

A. Design and Installation Considerations . . . . .	5
B. Tools and Supplies Needed . . . . .	5
C. Inspect Appliance and Components . . . . .	5
D. Inspect Firebox . . . . .	6

## 3 Fireplace Size Requirements

A. Minimum Fireplace Opening . . . . .	7
B. Clearances . . . . .	8 ←

## 4 Termination Locations

A. Vent Termination Minimum Clearances . . . . .	9
--	---

## 5 Vent Information and Diagrams

A. Vent Table Key . . . . .	10
B. Horizontal Venting . . . . .	10
C. Measuring Standards . . . . .	10

## 6 Installation Preparation

A. Flue Damper . . . . .	11
B. Chimney . . . . .	11
C. Gas Line . . . . .	11
D. Hearth or Hearth Extension . . . . .	11
E. Fireplace Conversion Notice . . . . .	11
F. Remote Control . . . . .	11

## 7 Installing Vent Pipe and Appliance

A. Venting Components . . . . .	12
B. Connecting Vent Pipe . . . . .	12
C. Placing, Securing and Leveling the Appliance . . . . .	13
D. Installing Adaptor and Termination Cap . . . . .	14

## 8 Gas Information

A. Fuel Conversions . . . . .	15
B. Gas Pressures . . . . .	15
C. Gas Connection . . . . .	15

## 9 Electrical Information

A. Wiring the Appliance . . . . .	17
B. Junction Box Installation . . . . .	18
C. Installation for Fan (Optional) . . . . .	18

## 10 Finishing

A. Mantel Projections . . . . .	20 ←
B. Installing Trim Surrounds . . . . .	20

## 11 Appliance Setup

A. Remove Shipping Materials . . . . .	21
B. Clean the Appliance . . . . .	21
C. Accessories . . . . .	21
D. Ember Placement . . . . .	21
E. Positioning the Logs . . . . .	22
F. Glass Assembly . . . . .	27
G. Air Shutter Setting . . . . .	27

## 12 Operating Instructions

A. Before Lighting Appliance . . . . .	28
B. Lighting Appliance . . . . .	29
C. Check Pilot Flame Appearance . . . . .	30
D. After Appliance is Lit . . . . .	30
E. Frequently Asked Questions . . . . .	31

## 13 Troubleshooting

A. Standing Pilot Ignition System . . . . .	32
---	----

## 14 Maintaining and Servicing Appliance

A. Maintenance Tasks . . . . .	34
--------------------------------	----

## 15 Reference Materials

A. Appliance Dimension Diagram . . . . .	36
B. Vent Kits Components . . . . .	37
C. Service Parts . . . . .	38
D. Limited Lifetime Warranty . . . . .	43
E. Contact Information . . . . .	45

→ = Contains updated information.

# 1 Listing and Code Approvals

## A. Appliance Certification

**MODELS:** FB-GRAND-S, FB-IN-S

**LABORATORY:** Underwriters Laboratories, Inc. (UL)

**TYPE:** Vented Gas Appliance Heaters

**STANDARD:** ANSI Z21.88-2002 • CSA2.33-M2003 • UL307B

This product is listed to ANSI standards for “Vented Gas Appliance Heaters” and applicable sections of “Gas Burning Heating Appliances for Manufactured Homes and Recreational Vehicles”, and “Gas Fired Appliances for Use at High Altitudes”.

**NOT INTENDED FOR USE AS A PRIMARY HEAT SOURCE.**

This appliance is tested and approved as either supplemental room heat or as a decorative appliance. It should not be factored as primary heat in residential heating calculations.

**Note:** To assure top performance, safety and efficiency, inserts must be installed with an approved flue liner as per CAN/CGA B-149 or National Fuel Gas Code ANSI Z223 and these instructions.

**Note:** This installation must conform with local codes. In the absence of local codes you must comply with the National Fuel Gas Code, ANSI Z223.1-latest edition in the U.S.A. and the CAN/CGA B149 Installation Codes in Canada.

## B. BTU Specifications

Models <i>U.S. (0-2000 ft.) or Canada (2000-4500 ft.)</i>		Maximum Input BTU/h	Minimum Input BTU/h	Orifice Size (DMS)
FB-GRAND-S (NG)	US	40,000	27,000	0.125 mm
	CANADA	36,000	24,300	31
FB-IN-S (NG)	US	38,000	27,000	31
	CANADA	34,200	24,300	32
FB-GRAND-S (LP)	US	34,000	28,900	50
	CANADA	31,000	19,000	51
FB-IN-S (LP)	US	34,000	28,900	50
	CANADA	31,000	19,000	51

## C. High Altitude Installations

U.L. Listed gas appliances are tested and approved without requiring changes for elevations from 0 to 2000 feet in the U.S.A. and Canada.

When installing this appliance at an elevation above 2000 feet, it may be necessary to decrease the input rating by changing the existing burner orifice to a smaller size. Input rate should be reduced by 4% for each 1000 feet above a 2000 foot elevation in the U.S.A., or 10% for elevations between 2000 and 4500 feet in Canada. If the heating value of the gas has been reduced, these rules do not apply. To identify the proper orifice size, check with the local gas utility.

If installing this appliance at an elevation above 4500 feet (in Canada), check with local authorities.

**⚠ WARNING**

Do NOT use this appliance if any part has been under water. Immediately call a qualified service technician to inspect the appliance and to replace any part of the control system and any gas control which has been under water.

## D. Non-Combustible Materials Specification

Material which will not ignite and burn. Such materials are those consisting entirely of steel, iron, brick, tile, concrete, slate, glass or plasters, or any combination thereof.

Materials that are reported as passing **ASTM E 136, Standard Test Method for Behavior of Materials in a Vertical Tube Furnace at 750° C**, shall be considered non-combustible materials.

## E. Combustible Materials Specification

Materials made of or surfaced with wood, compressed paper, plant fibers, plastics, or other material that can ignite and burn, whether flame proofed or not, or whether plastered or unplastered shall be considered combustible materials.

## F. Electrical Codes

**NOTICE:** This appliance must be electrically wired and grounded in accordance with local codes or, in the absence of local codes, with **National Electric Code ANSI/NFPA 70-latest edition or the Canadian Electric Code CSA C22.1.**

- A 110-120 VAC circuit for this product must be protected with ground-fault circuit-interrupter protection, in compliance with the applicable electrical codes, when it is installed in locations such as in bathrooms or near sinks.

## 2 Getting Started

### A. Design and Installation Considerations

Heat & Glo direct vent gas appliances are designed to operate with all combustion air siphoned from outside of the building and all exhaust gases expelled to the outside. No additional outside air source is required.

#### CAUTION

Check building codes prior to installation.

- Installation **MUST** comply with local, regional, state and national codes and regulations.
- Consult insurance carrier, local building, fire officials or authorities having jurisdiction about restrictions, installation inspection, and permits.

Heat & Glo gas inserts are designed for recessed installations into solid fuel masonry or factory built non-combustible fireplaces that have been installed in accordance with the National, Provincial, State and local building codes.

Prior to installing the gas insert:

- Have the chimney and adjacent structure inspected and cleaned by qualified professionals. Hearth & Home Technologies recommends that NFI or CSIA certified professionals, or technicians under the direction of certified professionals, conduct a minimum of a NFPA 211 Level 2 inspection of the chimney.
- Replace component parts of the chimney and fireplace as specified by the professionals.
- Ensure all joints are properly engaged and the chimney is properly secured.

When planning an appliance installation, it's necessary to determine the following information before installing:

- Minimum fireplace size. See Section 3.A.
- Gas supply piping.
- Electrical wiring.
- Finishing details.
- Existing mantel projections. See Section 10.
- Whether optional accessories—devices such as a fan, wall switch, or remote control—are desired.

### B. Tools and Supplies Needed

Before beginning the installation be sure that the following tools and building supplies are available.

Pliers	Hi temp caulking material
Hammer	Flat blade screwdriver
Voltmeter	Framing square
Gloves	Variable speed drill
1/4 Hex drive	Safety glasses
Manometer	Phillips screwdriver
Tape measure	Non-corrosive leak check solution
1/2 - 3/4 inch length, #6 or #8	Self-drilling screws

### C. Inspect Appliance and Components

#### ⚠ WARNING



Inspect appliance and components for damage. Damaged parts may impair safe operation.

- Do NOT install damaged components.
  - Do NOT install incomplete components.
  - Do NOT install substitute components.
- Report damaged parts to dealer.

- Carefully remove the appliance and components from the packaging.
- The vent system components, surrounds and fronts are shipped in separate packages.
- The fiber logs may be packaged separately and must be field installed.
- Report to your dealer any parts damaged in shipment, particularly the condition of the glass.
- **Read all of the instructions before starting the installation. Follow these instructions carefully during the installation to ensure maximum safety and benefit.**

#### ⚠ WARNING



Hearth & Home Technologies disclaims any responsibility for, and the warranty will be voided by, the following actions:

- Installation and use of any damaged appliance or vent system component.
- Modification of the appliance or vent system.
- Installation other than as instructed by Hearth & Home Technologies.
- Improper positioning of the gas logs or the glass door.
- Installation and/or use of any component part not approved by Hearth & Home Technologies.

**Any such action may cause a fire hazard.**

#### ⚠ WARNING



Keep appliance dry.

- Mold or rust may cause odors.
- Water may damage controls.



## D. Inspect Firebox

Surface cracking or crazing of firebrick material is normal and expected. The following types of cracks are acceptable and do not require replacement of the unit or the firebox:

- Cracks that do not propagate entirely through the material.
- Light fracture lines or “spider-webbing” on the surface of the material.
- Cracks that are less than 1/32 in. wide and less than 3 in. long.
- If cosmetically unacceptable, such cracks may be repaired with the SRV-PACK service kit. See Service Parts List.

Cracks that are unacceptable:

- Cracks greater than 1/32 in. wide and 3 in. long are at risk of growing.
- Cracks that penetrate entirely through the firebrick material.

Inspection for cracking should be run when the appliance is cool. Cracks tend to close as the appliance heats up.

# 3 Fireplace Size Requirements

## A. Minimum Fireplace Opening

Minimum fireplace opening requirements are shown in Figure 5.1.

**WARNING! Risk of Fire or Burns!** Provide adequate clearance around air openings and for service access. **Due to high temperatures, the appliance should be located out of traffic and away from furniture and draperies.**

- The firebrick (refractory), glass doors, screen rails, screen mesh and log grates can be removed from a factory built firebox in order to gain minimum gas insert opening requirements.
- Any smoke shelves, shields and baffles may be removed from the factory built firebox if attached with mechanical fasteners.

- The metal floor of the solid fuel firebox may be removed to facilitate the installation of the insert. The appliance may not be placed directly on the base of the outer wrap, a 1/4 inch airspace must be provided between the insert and the floor of the outer wrap. Use the levelling legs to raise the insert a minimum of 1/4 inch. The original fireplace may never be returned to solid fuel in this condition. The sidewalls and top structure of the firebox may not be altered with the exception of removable baffles and dampers.
- Cutting of any sheet metal parts of the fireplace in which the gas fireplace insert is to be installed is prohibited, except the floor as tested for and as noted above.

NOTE: For actual appliance dimensions refer to Section 15.

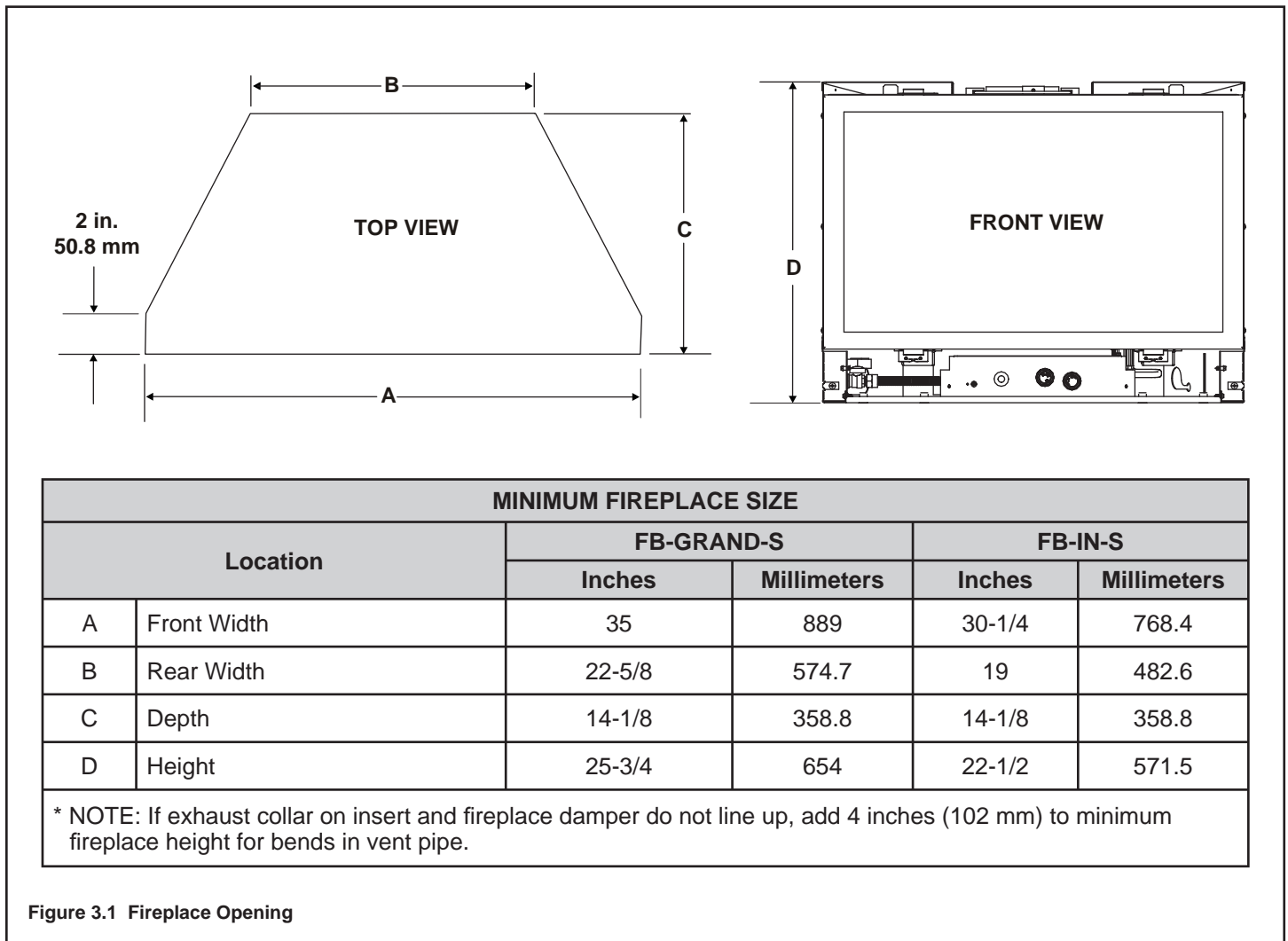

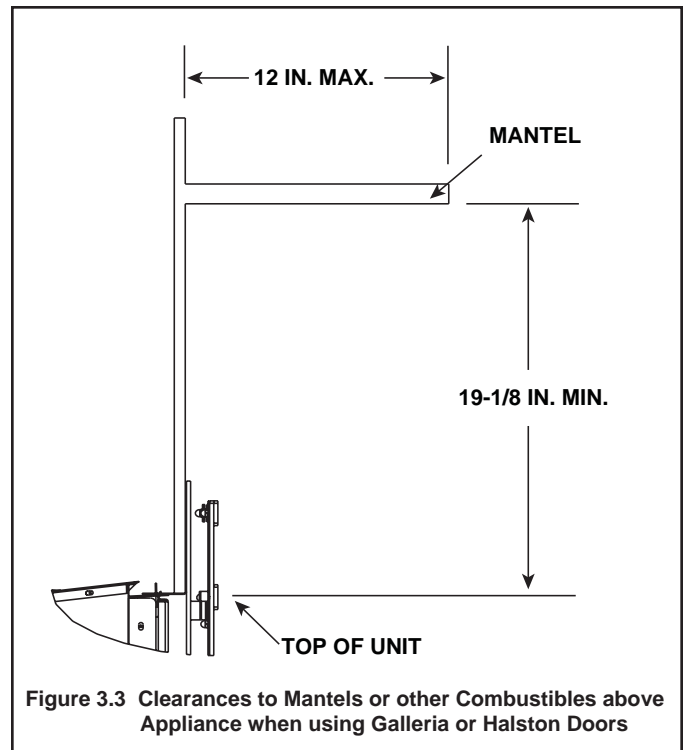
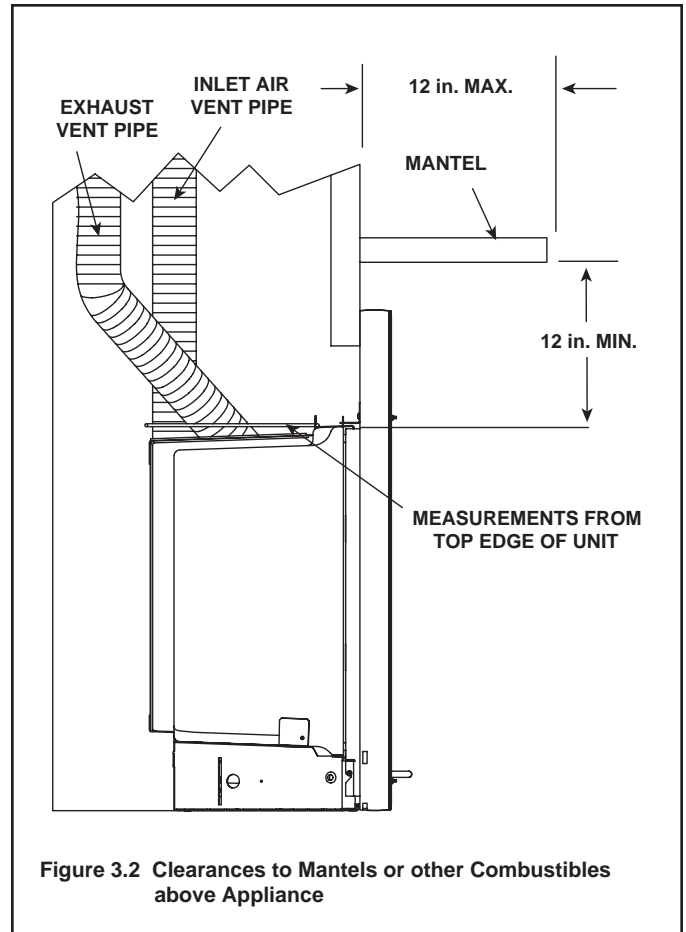

Figure 3.1 Fireplace Opening

## B. Clearances

	<b>⚠ WARNING</b>
	<p>Fire Risk. Odor Risk.</p> <ul style="list-style-type: none"> <li>• Clearance to combustible material under the insert is 1/4 inch (0.6 cm).</li> <li>• Use leveling legs to raise insert minimum 1/4 inch above combustible material or outer wrap of factory built firebox.</li> </ul>

	<b>⚠ WARNING</b>
	<p>Fire Risk.</p> <ul style="list-style-type: none"> <li>• Locate and install appliance to all clearance specifications in manual.</li> </ul>





# 4 Termination Locations

## A. Vent Termination Minimum Clearances

Figure 4.1 specifies minimum vent heights for various pitched roofs.

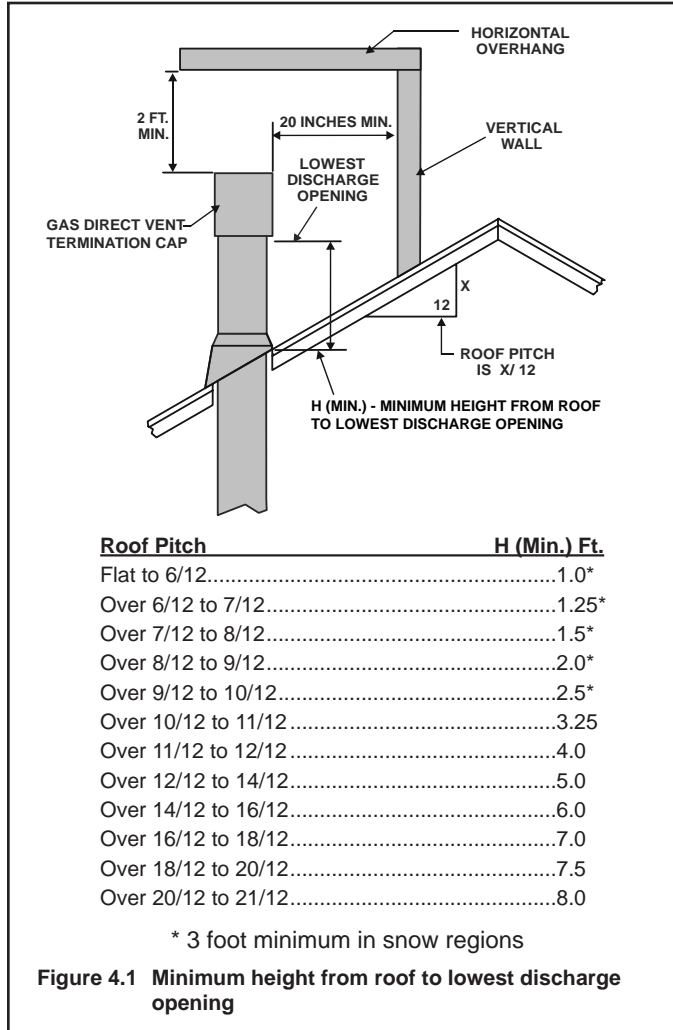

**⚠ WARNING**

Fire Risk.

Asphyxiation Risk.

- Terminations **MUST** meet minimum clearances.
- Exhaust gases are hot.
- Nearby vents may draw fumes into house.

# 5 Vent Information and Diagrams

## A. Vent Table Key

The abbreviations listed in this vent table key are used in the vent diagrams.

Symbol	Description
$V_{MIN}$	Minimum Vertical Run Length 14 ft.
$V_{MAX}$	Maximum Vertical Run Length 50 ft.

## B. Horizontal Venting

Horizontal venting is NOT allowed.

## C. Measuring Standards

Vertical measurements listed in the vent diagram (Figure 5.1) were made using the following standard:

- Vertical terminations are measured to top of chimney.

**⚠ WARNING**



Fire Hazard.  
Explosion Risk.  
Asphyxiation Risk.

Do NOT connect this gas appliance to a chimney flue serving a separate solid fuel or gas burning appliance.

- May impair safe operation of this appliance or other appliances connected to the flue.
- Vent this appliance directly outside.
- Use separate vent system for this appliance.

**CAUTION**

ALL vent specifications MUST be followed.

- This product is tested and listed to these specifications.
- Appliance performance will suffer if specifications are not followed.

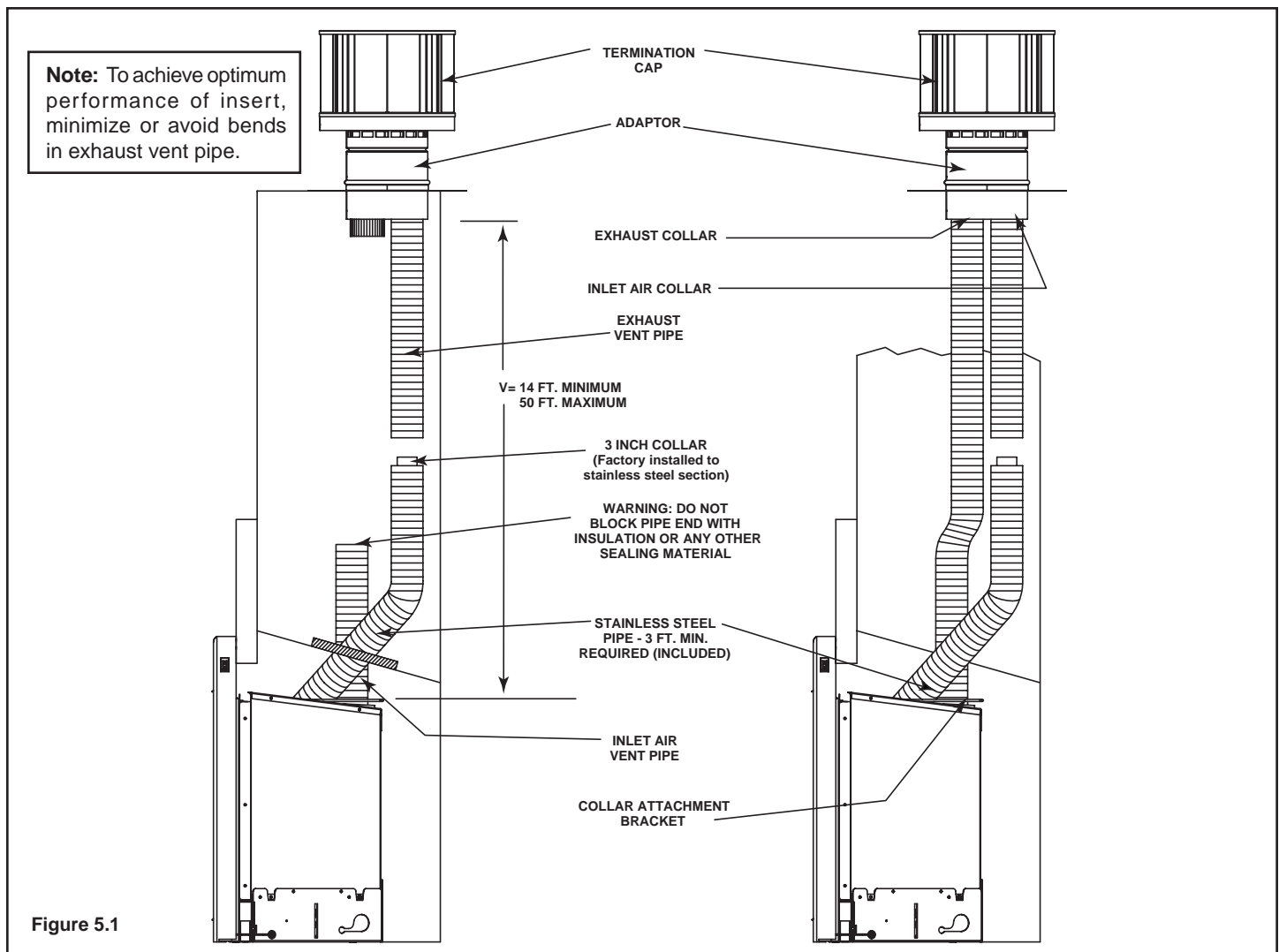

Figure 5.1

# 6 Installation Preparation

Prepare the existing solid fuel masonry or factory built non-combustible firebox for installation.

## A. Flue Damper

Fully lock the solid fuel fireplace's flue damper in the open position, OR completely remove it.

## B. Chimney

- Ensure chimney is constructed of non-combustible materials.
- Ensure chimney is clean and in good working order.
- Ensure that all chimney cleanouts fit properly to prevent air leakage into chimney.

## C. Gas Line

**Note:** If the factory built fireplace has no gas access hole provided, an access hole of 1 inch (25 mm) diameter or less may be drilled through the lower sides or bottom of the firebox in a proper workmanship - like manner. This access hole must be plugged with non-combustible insulation after the gas supply line has been installed.

- Install gas line into firebox cavity.
- Check local codes and gas line sizing requirements following NFPA54. See Section 8.

## D. Hearth or Hearth Extension

<b>⚠ WARNING</b>	
	Fire Risk.
	A hearth or hearth extension (if present) <u>must</u> comply with either of the following:
	<ul style="list-style-type: none"><li>• The solid fuel burning fireplace manufacturer's specification.</li><li>• Local building codes required by authority having jurisdiction.</li><li>• NFPA 211</li></ul>

## E. Fireplace Conversion Notice

Permanently attach the label with the following warning to the inside lower back of the fireplace firebox into which the insert is being installed. Silicone may be required to properly secure the label.

<b>⚠ WARNING</b>	
	Fire Risk.
	This fireplace has been converted for use with a gas fireplace insert only and cannot be used for burning wood or solid fuels unless all original parts have been replaced, and the fireplace re-approved by the authority having jurisdiction.

Prior to installing the gas insert:

- Have the chimney and adjacent structure inspected and cleaned by qualified professionals. Hearth & Home Technologies recommends that NFI or CSIA certified professionals, or technicians under the direction of certified professionals, conduct a minimum of a NFPA 211 Level 2 inspection of the chimney.
- Replace component parts of the chimney and fireplace as specified by the professionals.
- Ensure all joints are properly engaged and the chimney is properly secured.

## F. Remote Control

The receiver for the remotes must be installed BETWEEN the base pan of the insert and the firebox of the wood-burning fireplace (see photo below).

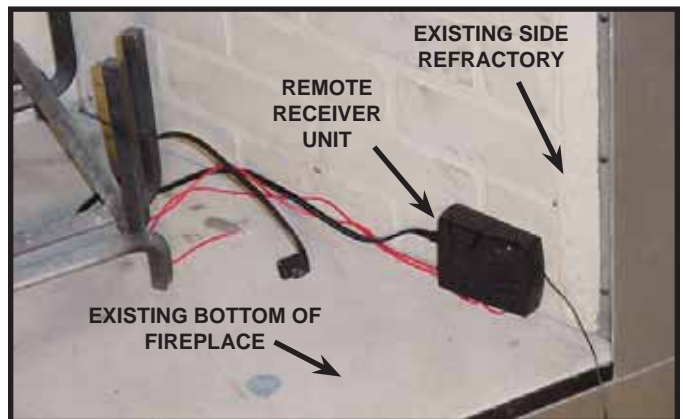

# 7 Installing Vent Pipe and Appliance

## A. Venting Components



**CAUTION**

Sharp Edges

- Wear protective gloves and safety glasses during installation.



The vertical vent termination system installed on this model includes:

- One 3-foot section stainless steel flexible pipe (included with insert).
- One length of 3-inch flexible vent pipe for combustion air (included with vent kit).
- Flexible vent pipe for exhaust air (included with vent kit).
- One pipe-to-cap adaptor (included with vent kit).
- One vertical termination cap (included with vent kit).

## B. Connecting Vent Pipe

Reference instructions in the termination kit.

- Install the 3-inch flexible vent pipe(s) down through the chimney.
- Secure the exhaust flexible vent pipe to the 3 foot section stainless steel flexible vent pipe using the factory-installed 3-inch collar in the stainless steel section of pipe (see Figure 7.1).
- Use 3 screws to attach either a 4 foot or 30 foot section of inlet air vent to the inlet collar on the collar slide plate (see Figure 7.1). NOTE: The collar slide plate may be removed from appliance to aid installation.
- Seal opening between flex vent and chimney just above insert. Unfaced fiberglass insulation may be used for this purpose.

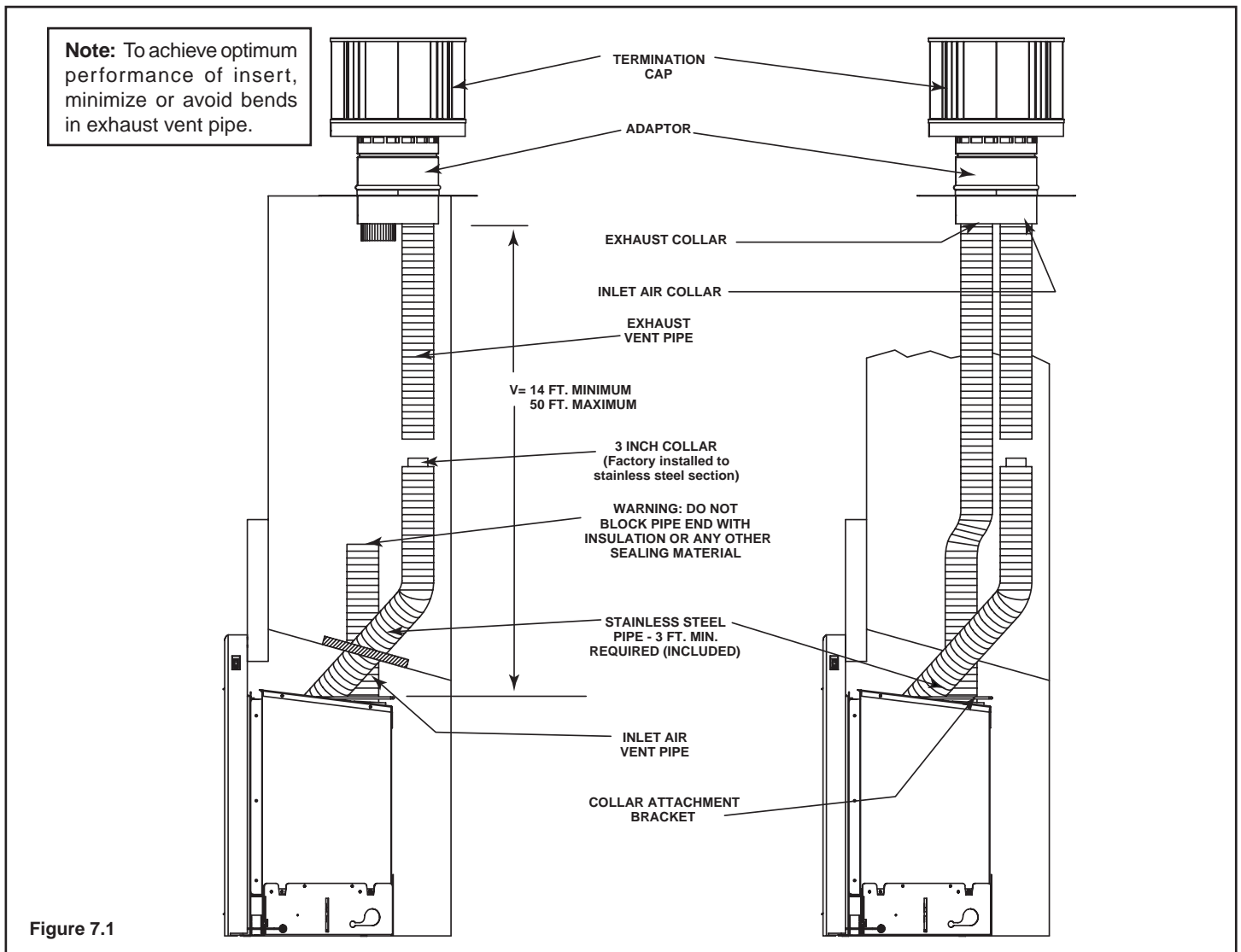

Figure 7.1

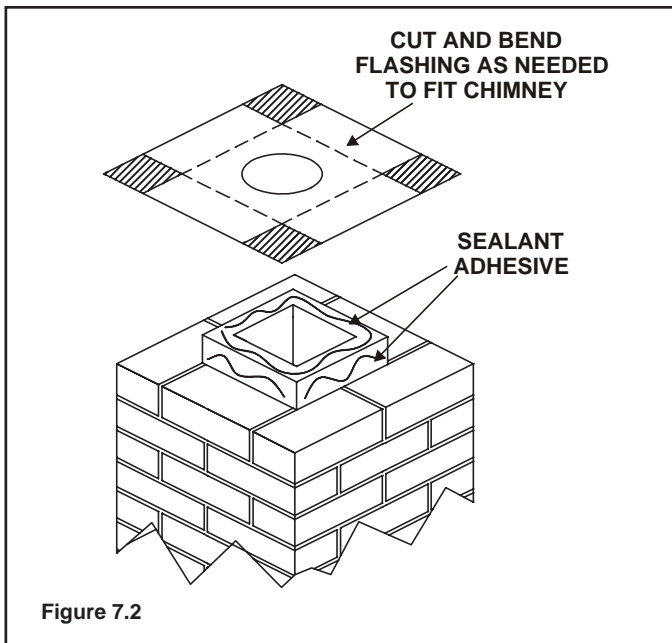

Figure 7.2

- Trim chimney top plate to minimize excess overhang or bend over flue tile (see Figure 7.2).
- Place 3/8 inch bead of 300° F silicone on flue tile top.

### C. Placing, Securing and Leveling the Appliance

- Install insert (without surround attached) into existing fireplace while pulling collar slide plate forward.
- Install gas line into hole provided on insert side.
- If applicable install remote control wires into insert side (see Section 6, F.).
- Secure collar slide plate to appliance by placing locking handle into position with locking tabs (see Figure 7.1) and secure with #8 screw.
- Level the appliance from side to side and front to back. If necessary, use the leveling legs included with the insert to set each corner of the base.
- Position any excess flexible vent pipe back up into chimney without sagging. Twist and push flex vent together to shorten.
- Install fiberglass insulation pieces to back face of surround.
- Attach surround. Follow instructions accompanying surround.
- Push insert so that surround becomes tight against face of fireplace.

### ⚠ WARNING



Fire Risk.

Only an approved Hearth & Home Technologies surround may be used to cover integral grills on solid fuel burning fireplaces.

- No other components such as shrouds, sheet-metal plates, etc., may be used to seal off vents.

### ⚠ WARNING

Failure to position the parts in accordance with these diagrams or failure to use only parts specifically approved with this appliance may result in property damage or personal injury.

### ⚠ WARNING



Explosion Risk.

Combustion Fume Risk.

- Connect vent sections per installation instructions.
- The 3 foot section of stainless steel flexible pipe **MUST** be attached directly to the exhaust collar on the collar slide plate.
- Connect exhaust vent pipe **ONLY** to exhaust starting collar and termination cap center collar.
- Connect inlet air vent **ONLY** to inlet air collar on appliance and either the termination cap inlet air collar **OR** terminate within chimney.
- Do **NOT** allow vent to sag below connection point to appliance.

## D. Installing Adaptor and Termination Cap

For installation of termination cap see minimum vent heights for various pitched roofs (see Figure 7.2) .

To install adaptor see Figure 7.3.

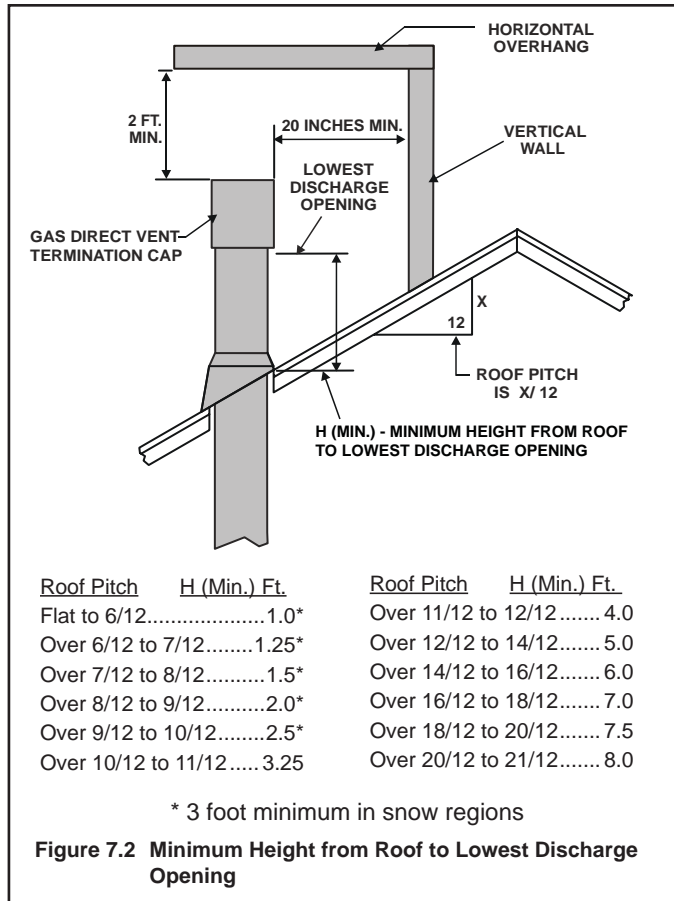

### CAUTION

Sharp Edges

- Wear protective gloves and safety glasses during installation.

### Damper Flashing Kit (Optional)

For use with LINK-DV4-30B Liner Kit.

**Note:** Damper may have to be removed to use this kit.

- Run flex liners through 3" holes in damper flashing.
- Attach damper flashing to firebox roof with self tapping screws included in kit.

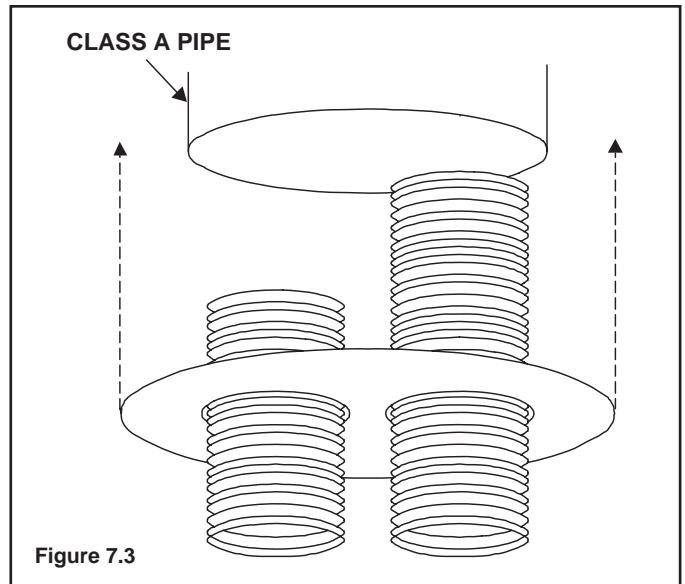

To help eliminate cold air drafts, it may be necessary to place non-combustible insulation around the flues as they go through the damper.

**Note:** The LINK-DV4-30B system **REQUIRES** this insulation.

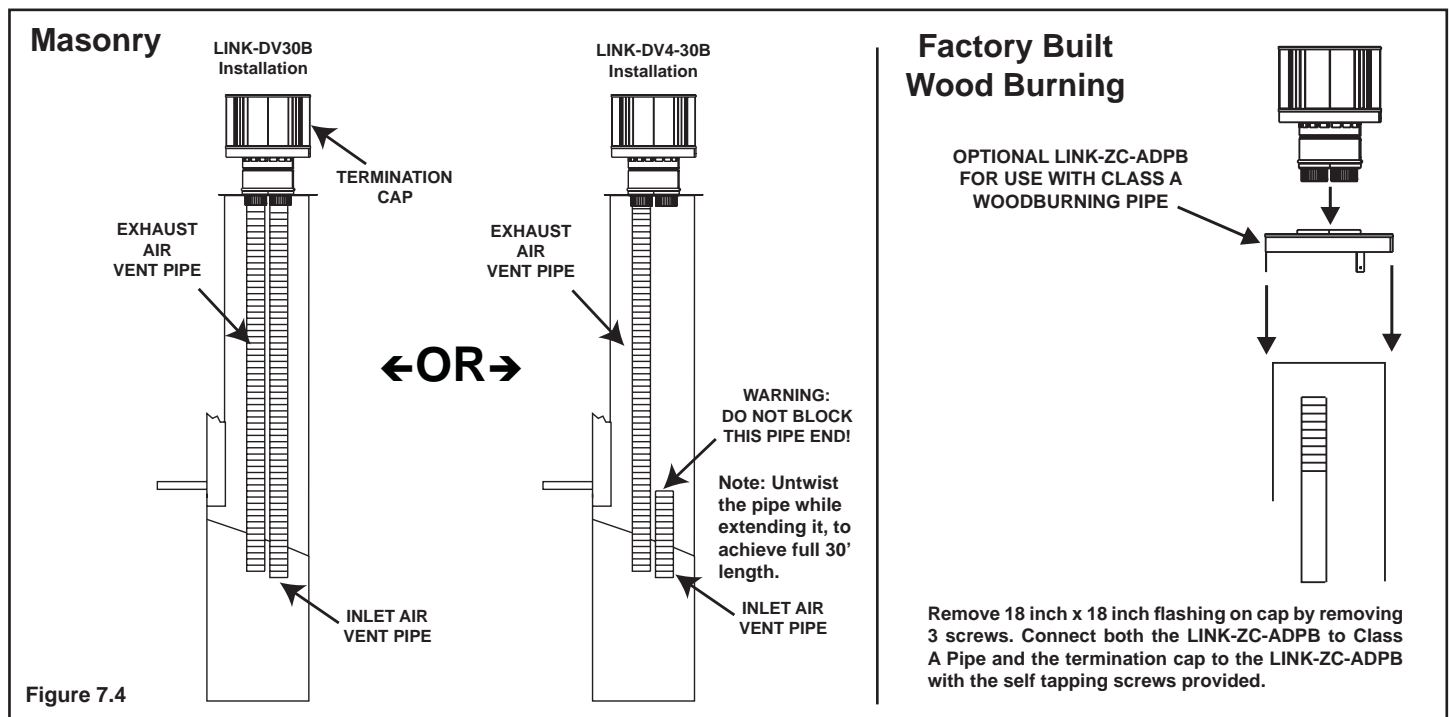

# 8 Gas Information

## A. Fuel Conversions

Before making gas connections ensure that appliance being installed is compatible with the available gas type.

Any natural or propane gas conversions necessary to meet the appliance and locality needs must be made by a qualified technician using Hearth & Home Technologies specified and approved parts.

## B. Gas Pressures

Proper input pressures are required for optimum appliance performance. Gas line sizing requirements need to be made following NFPA54.

**⚠ WARNING**



Fire Risk.  
Explosion Hazard.  
High pressure will damage valve.

- Disconnect gas supply piping BEFORE pressure testing gas line at test pressures above 1/2 psig.
- Close the manual shutoff valve BEFORE pressure testing gas line at test pressures equal to or less than 1/2 psig.

**⚠ WARNING**



Verify inlet pressures.

- High pressure may cause overfire condition.
- Low pressure may cause explosion.
- Verify minimum pressures when other household gas appliances are operating.

Install regulator upstream of valve if line pressure is greater than 1/2 psig.

Pressure requirements for appliance are shown in the table below. Minimum pressures must be met when other household gas appliances are operating.

Pressure	Natural Gas	Propane
Minimum inlet pressure	5.0 inches w.c.	11.0 inches w.c.
Maximum inlet gas pressure	14.0 inches w.c.	14.0 inches w.c.
Manifold pressure	3.5 inches w.c.	10.0 inches w.c.

## C. Gas Connection

**Note:** Have the gas supply line installed in accordance with local building codes, if any. If not, follow ANSI 223.1. Installation should be done by a qualified installer approved and/or licensed as required by the locality. (In the Commonwealth of Massachusetts installation must be performed by a licensed plumber or gas fitter).

**NOTE:** A listed (and Commonwealth of Massachusetts approved) 1/2 inch (13 mm) T-handle manual shut-off valve and flexible gas connector are connected to the 1/2 inch (13 mm) control valve inlet.

- **If substituting for these components, please consult local codes for compliance.**

Refer to **Reference Section 15** for location of gas line access in appliance.

**NOTE:** Gas line may be run from either side of the appliance provided the hole in the outer wrap does NOT exceed 2-1/2 inches in diameter and does not penetrate the firebox.

**⚠ WARNING**



Gas Leak Risk

- Support control when attaching pipe to prevent bending gas line.

**NOTE:** The gap between supply piping and gas access hole may be caulked with high temperature caulk or stuffed with non-combustible, unfaced insulation to prevent cold air infiltration.

- Ensure that gas line does not come in contact with outer wrap of appliance. Follow local codes.
- Incoming gas line should be piped into the valve compartment and connected to the 1/2 inch connection on the manual shutoff valve.
- Check all fittings and connections of appliance which may have loosened during shipping.

**⚠ WARNING**



**Fire or Explosion Hazard**

- Gas buildup during line purge may ignite.
- Purge should be performed by qualified technician.
- Ensure adequate ventilation.
- Ensure there are no ignition sources such as sparks or open flames.



- A small amount of air will be in the gas supply lines. When first lighting appliance it will take a short time for air to purge from lines. When purging is complete the appliance will light and operate normally.

**⚠ WARNING**



**CHECK FOR GAS LEAKS**

Explosion Risk

Fire Risk

Asphyxiation Risk

- Check all fittings and connections.
- Do not use open flame.
- After the gas line installation is complete, all connections must be tightened and checked for leaks with a commercially-available, non-corrosive leak check solution. Be sure to rinse off all leak check solution following testing.



Fittings and connections may have loosened during shipping and handling.

**⚠ WARNING**



Fire hazard.

Do NOT change the valve settings.

- This valve has been preset at the factory.
- Changing valve settings may result in fire hazard or bodily injury.

**HIGH ALTITUDE INSTALLATIONS**

U.L. Listed gas appliances are tested and approved without requiring changes for elevations from 0 to 2000 feet in the U.S.A. and Canada.

When installing this appliance at an elevation above 2000 feet, it may be necessary to decrease the input rating by changing the existing burner orifice to a smaller size. Input rate should be reduced by 4% for each 1000 feet above a 2000 foot elevation in the U.S.A., or 10% for elevations between 2000 and 4500 feet in Canada. If the heating value of the gas has been reduced, these rules do not apply. To identify the proper orifice size, check with the local gas utility.

If installing this appliance at an elevation above 4500 feet (in Canada), check with local authorities.



# 9 Electrical Information

## A. Wiring the Appliance

**Note:** Electrical wiring must be installed by a licensed electrician.

**Note:** This appliance must be electrically wired and grounded in accordance with local codes or, in the absence of local codes, with **National Electric Code ANSI/NFPA 70-latest edition** or the **Canadian Electric Code, CSA C221.1**.



- A 110-120 VAC circuit for this product must be protected with ground-fault circuit-interrupter protection, in compliance with the applicable electrical codes, when it is installed in locations such as in bathrooms or near sinks.

### CAUTION

- Prevent accidental appliance operation when not attended.
- Unplug or remove batteries from remote control if absent or if appliance will not be used for an extended period of time.
- Property damage possible from elevated temperatures.

## Appliance Requirements

- This appliance DOES NOT require 110-120 VAC to operate.
- It is recommended that a 110 VAC junction box be connected for use with fan or remote control. (See Figure 9.2 for junction box wiring).

 	<b>⚠ WARNING</b>
	<p>Wire 110V to electrical junction box. Do NOT wire 110V to valve. Do NOT wire 110V to wall switch.</p> <ul style="list-style-type: none"> <li>• Incorrect wiring will damage millivolt valves.</li> <li>• Incorrect wiring will override IPI safety lockout and may cause explosion.</li> </ul>

## ON/OFF Switch

- An ON/OFF switch is included with the decorative surround/decorative front and should be attached to surround/facing. (See Installation instructions for remote control).
- If desired an additional wall switch or thermostat may be added to system as shown in Figure 9.1.

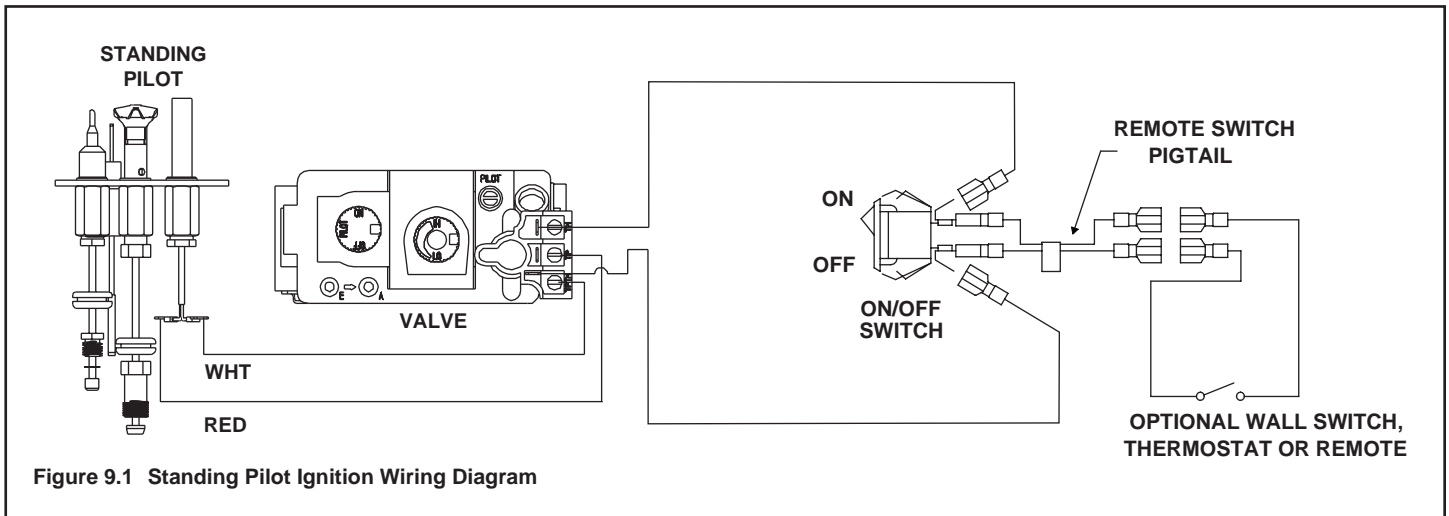

## B. Junction Box Installation

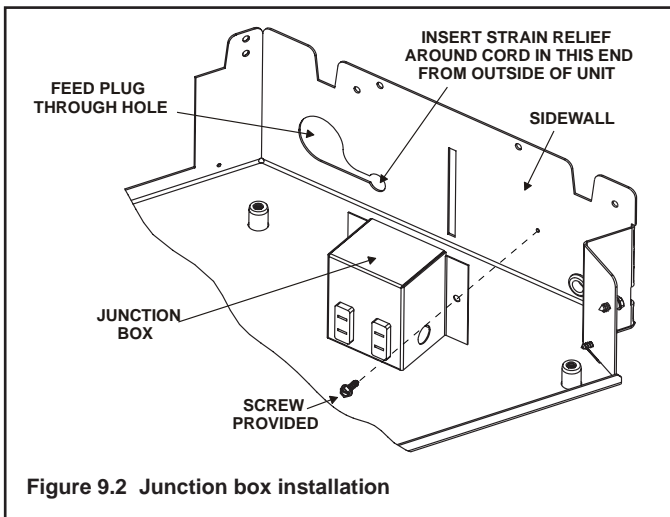

Figure 9.2 Junction box installation

### Optional Accessories

Connecting the electrical junction box is required if using a blower or remote.

- Plug the cord into a convenient outlet.
- An electrician may install an outlet box inside the fireplace. Place the outlet in the lower, back corner of the fireplace.
- Must use cord supplied.

## CAUTION

Label all wires prior to disconnection when servicing controls. Wiring errors can cause improper and dangerous operation. Verify proper operation after servicing.



## WARNING

Shock hazard.

- Replace damaged wire with type 105° C rated wire.
- Wire must have high temperature insulation.

## C. Installation for Fan (Optional)

On units already installed removal of decorative front, surround and gas insert is required.

- Detach flexible liner from back of unit if insert is installed.
- Remove the four screws on the cover plate (see Figure 9.3).

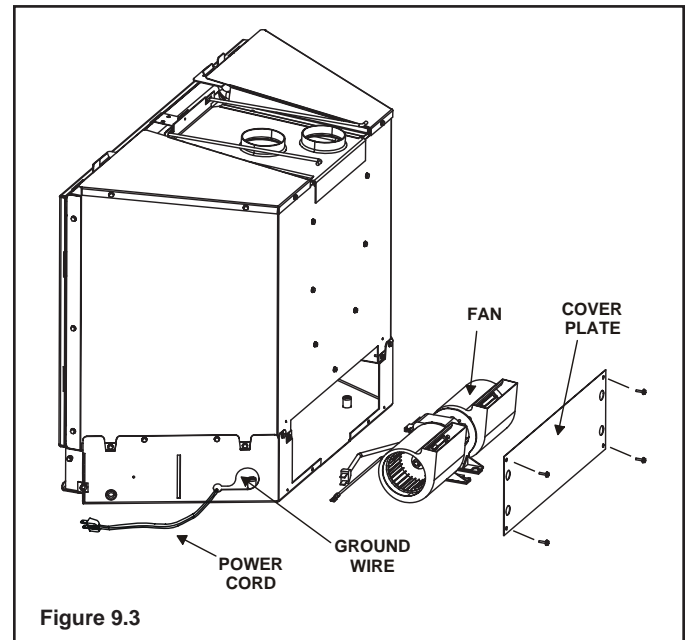
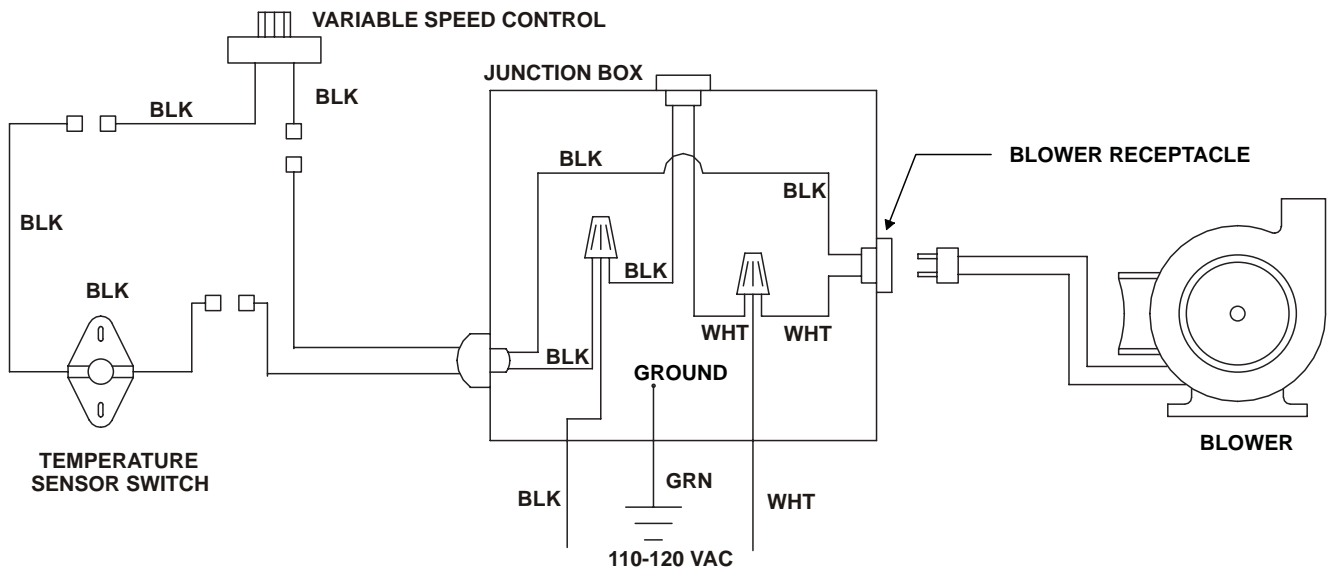

Figure 9.3

- Bend up the tabs on the base pan (see Figure 9.4).
- Place the blower in between the bend up tabs.
- Install and wire the blower per instruction shipped with the fan.
- The ground wire of the fan can clip on the side of the base pan.
- Reinstall the cover plate back on the unit. Make sure the fan does not make contact with the back wall to prevent noise from vibration.



NOTE: IF ANY OF THE ORIGINAL WIRE AS SUPPLIED WITH THE APPLIANCE MUST BE REPLACED, IT MUST BE REPLACED WITH TYPE 105° C RATED WIRE.

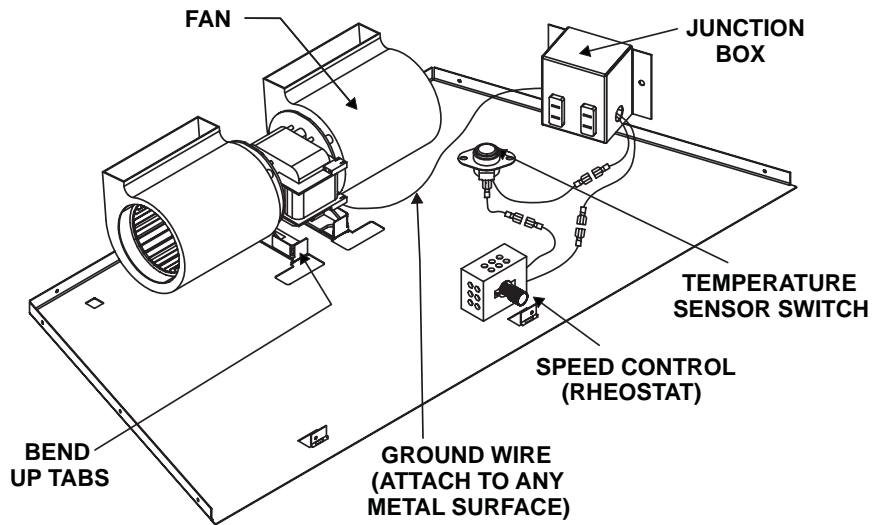

Figure 9.4 Fan Wiring Diagram

# 10 Finishing

## A. Mantel Projections

Figure 10.1 shows the minimum vertical and corresponding maximum horizontal dimensions of appliance mantels or other combustible projections above the top front edge of the appliance, not the surround. See Figure 10.2 for required clearances when using Halston or Galleria Doors.

→ **Note:** When using Galleria or Halston Doors with FB-GRAND-S and FB-IN-S, a 19-1/8 inch minimum vertical distance from top of unit to bottom of mantel is required.

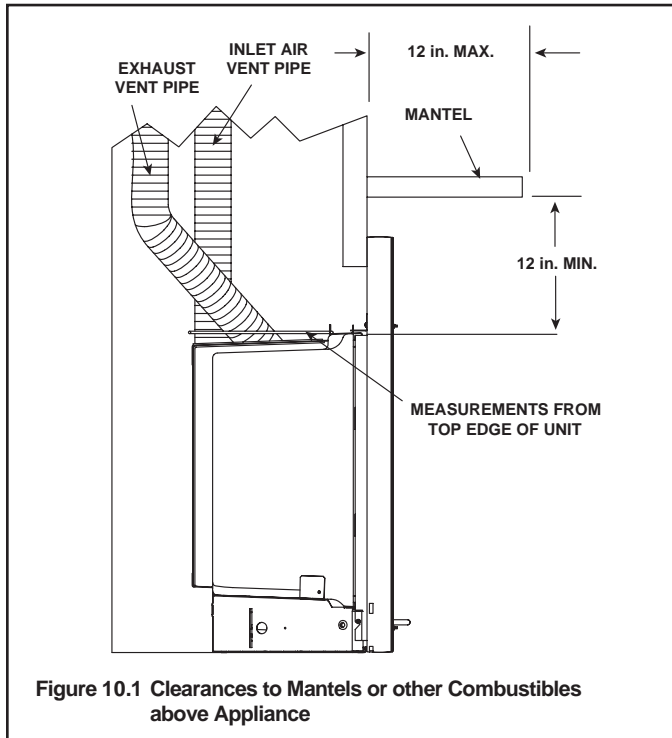

Figure 10.1 Clearances to Mantels or other Combustibles above Appliance

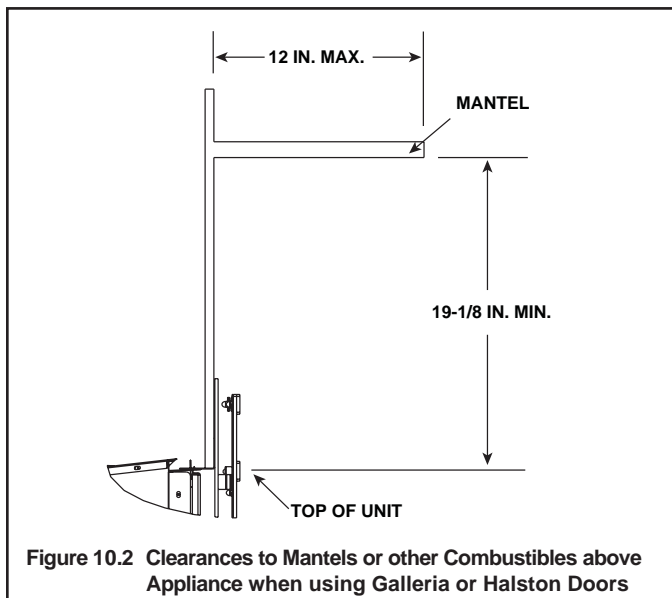

Figure 10.2 Clearances to Mantels or other Combustibles above Appliance when using Galleria or Halston Doors

## B. Installing Trim Surrounds

Combustible materials **MUST NEVER** overlap onto the front face.

1. Find the coiled low voltage wires and ON/OFF switch attached to outer right side of the insert (see Figure 10.2).
2. Reconnect the low voltage wires to the ON/OFF switch.
3. Attach surround assembly by hooking the support bracket on the locating tabs on top of the gas insert fireplace (see Figure 10.2.) Once the surround assembly is on the locating tabs, ensure the bottom hooks are resting on the locating pins at the base. Reposition the fireplace if necessary. Refer to surround instructions provided with the decorative surround.

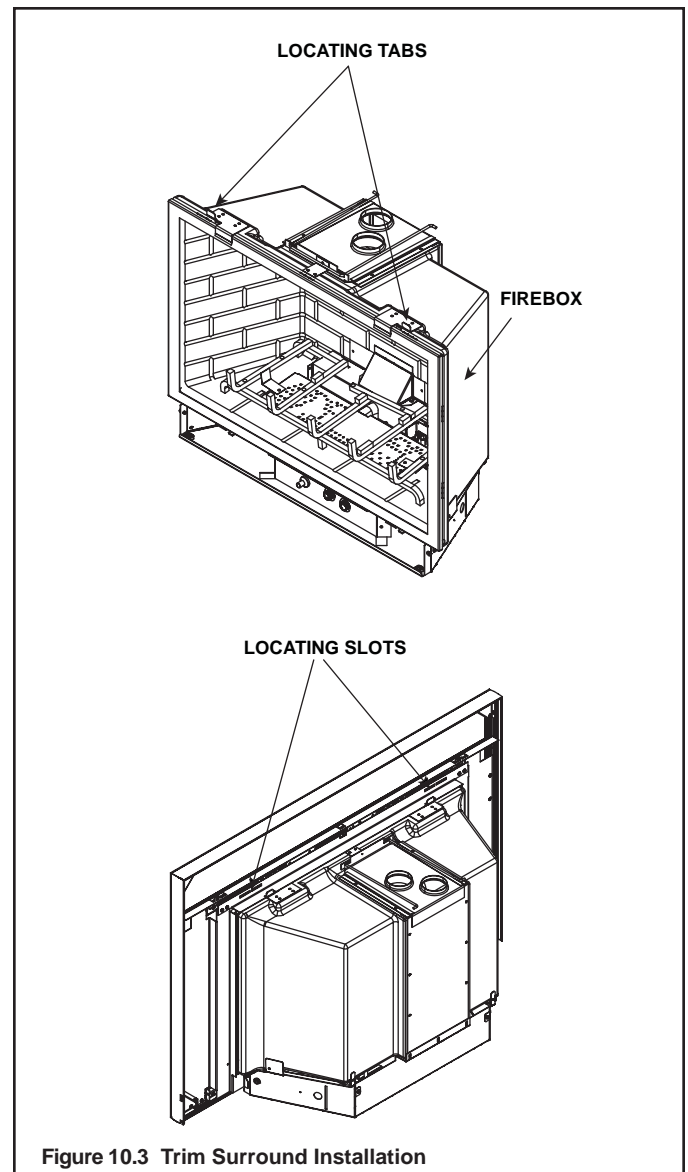

Figure 10.3 Trim Surround Installation

# 11 Appliance Setup

## A. Remove Shipping Materials

Remove shipping materials from inside or underneath the firebox.

## B. Clean the Appliance

Clean/vacuum any sawdust that may have accumulated inside the firebox or underneath in the control cavity.

## C. Accessories

Install approved accessories per instructions included with accessories. See Service Parts List for appropriate accessories.

	<b>⚠ WARNING</b>
	Shock or fire risk. Use <b>ONLY</b> optional accessories approved for this appliance. <ul style="list-style-type: none"><li>• Using non-listed accessories voids warranty.</li><li>• Using non-listed accessories may result in a safety hazard.</li><li>• Only Hearth &amp; Home Technologies approved accessories may be used safely.</li></ul>

## D. Ember Placement

	<b>⚠ WARNING</b>
	Explosion Risk. <ul style="list-style-type: none"><li>• Follow ember placement instructions in manual.</li><li>• Do <b>NOT</b> place embers directly over burner ports.</li><li>• Replace ember material annually.</li></ul> Improperly placed embers interferes with proper burner operation.

## Placing the Ember Material

Ember material is shipped with this gas appliance. To place the ember material:

- Embers **CANNOT** be placed directly over ports.
- When placing Glowing Embers® onto the burner care should be taken so that the ports are not covered. Place the dime-size ember pieces near port holes in burner top, sides and front (see Figure 11.1). Failure to follow this procedure will likely cause lighting and sooting problems.

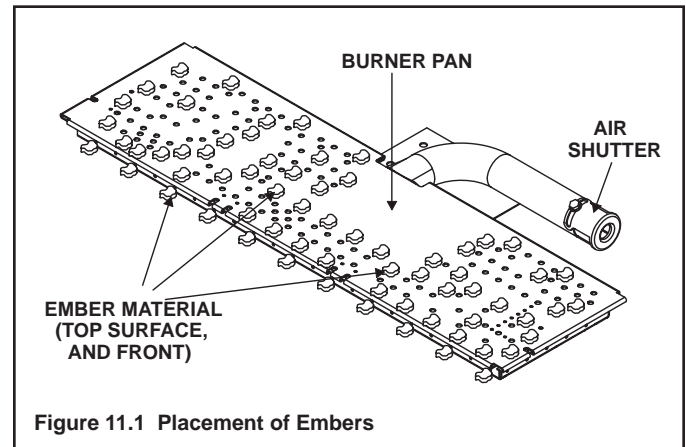

Figure 11.1 Placement of Embers

- Place Mystic Ember over burner surface and around base of burner. Do not cover any burner port holes. Use this material to give the appliance a realistic ash bed.
- Save the remaining ember materials for use during appliance servicing. The embers provided should be enough for 3 to 5 applications.

**CAUTION:** Logs are fragile! Carefully remove the logs from the packaging.



Log Set (QVI35FB-S Shown)

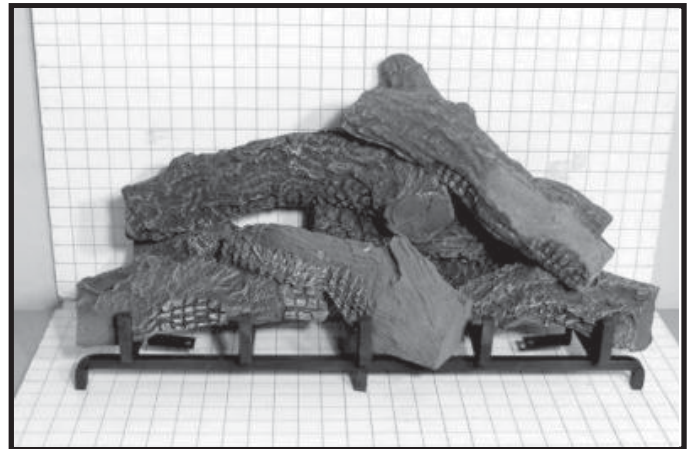

Log Set (FB-GRAND-S Shown)

This model uses locating tabs to positively locate the logs with respect to the grate assembly.

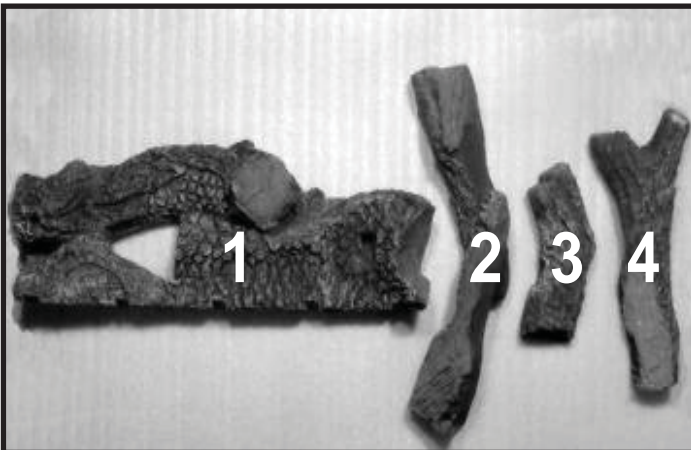

Logs

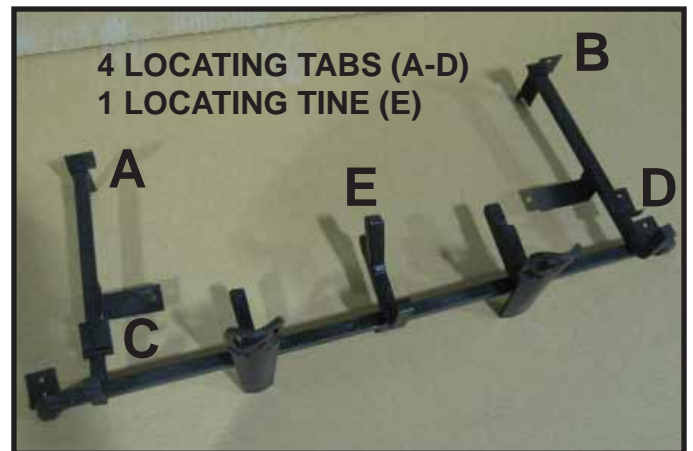

Locating Tabs



**LOG NUMBER 1 (SRV768-701):** Place log #1 onto the grate. Push log back until it rests against locating tabs A and B. Slide the log all the way to the left until the notches on the bottom of the log contact the grate bars.

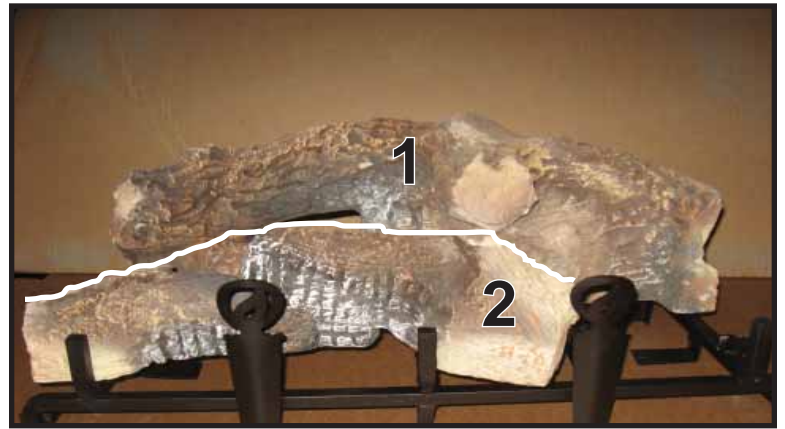

**LOG NUMBER 2 (SRV768-704):** Position log #2 onto grate such that tab C fits into the slot on the bottom surface of the log. The right side of the log rests between the front grate tine and locating tine E. The cutout on the log should contact the corresponding tine.



**LOG NUMBER 3 (SRV768-705):** Position log #3 onto grate such that tab D fits into slot on bottom surface of log. Push down until log is sitting flat on grate.

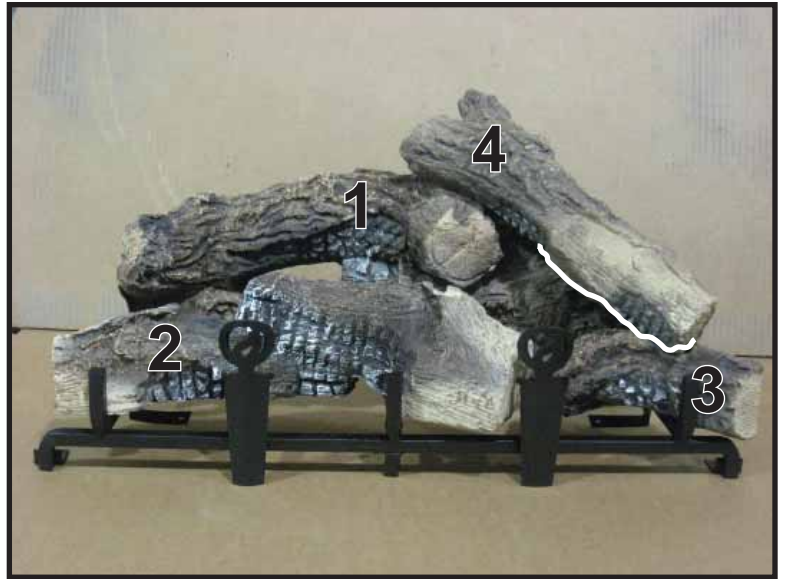

**LOG NUMBER 4 (SRV582-705):** Place log #4 across both flat spots on log #1 and log #3, with the “Y” in log #4 placed on log #1. The back of log #4 should make contact with the back of the firebox.



**Log Assembly: LOGS-CFXINB**

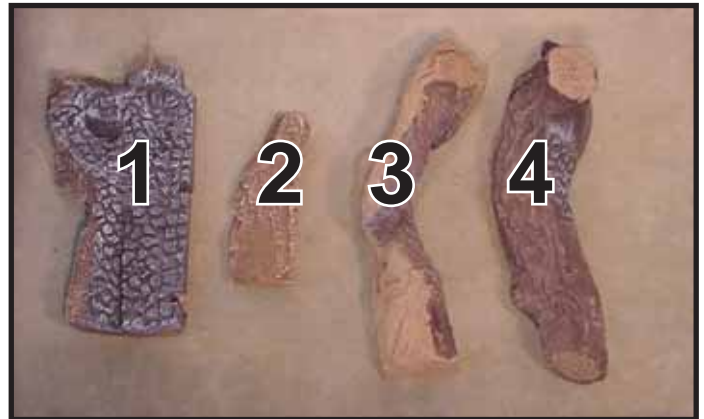

Carefully remove the logs from the packaging. **CAUTION:** Logs are fragile!

**GRATE ASSEMBLY**

This model uses locating tabs to positively locate the logs with respect to the grate assembly. Please refer to grate assembly.

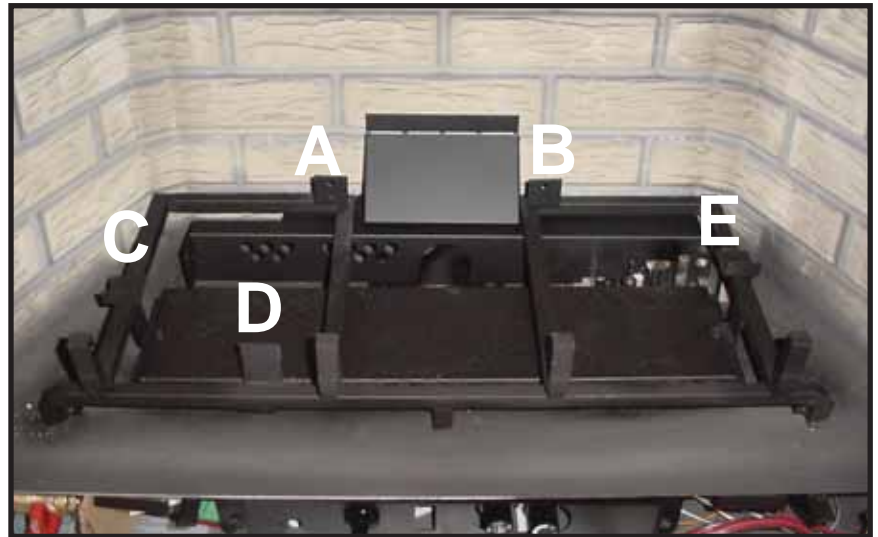

**LOG #1 (SRV773-701):** Position log #1 onto the grate such that grooves on bottom of log #1 mate with grate. Push log back until it rests against locating tabs A and B.



**LOG #2 (SRV773-702):** Position Log #2 onto grate such that tab C fits into the slot on bottom surface of log.

Flat Spot for Log #4



**LOG #3 (SRV768-704):** Position log #3 onto grate such that the tab D fits into the slots on bottom surface of log and the right back side of log is flush against tab E.

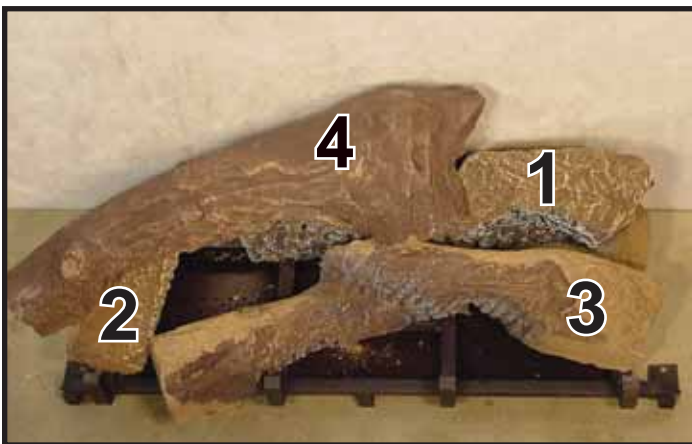

**LOG #4 (SRV573-702):** Place log #4 into the flat spot on the log #1 and the left side of the log will rest on log #2 as shown.

## F. Glass Assembly

 <b>WARNING</b>	<p>Handle glass doors with care.</p> <ul style="list-style-type: none"> <li>• Inspect the gasket to ensure it is undamaged.</li> <li>• Inspect the glass for cracks, chips or scratches.</li> <li>• Do NOT strike, slam or scratch glass.</li> <li>• Do NOT operate appliance with glass door removed, cracked, broken or scratched.</li> <li>• Replace glass door assembly as a complete appliance.</li> </ul>
--	---

### Removing Glass Assembly

There are two glass latches on the bottom of glass assembly.

- To release glass assembly, pull latch forward and allow to retract away from glass assembly.
- Remove glass assembly after both latches have been released (see Figure 11.16).

### Replacing Glass Assembly

Replace the glass door on the appliance. Fasten the latches on the glass frame.

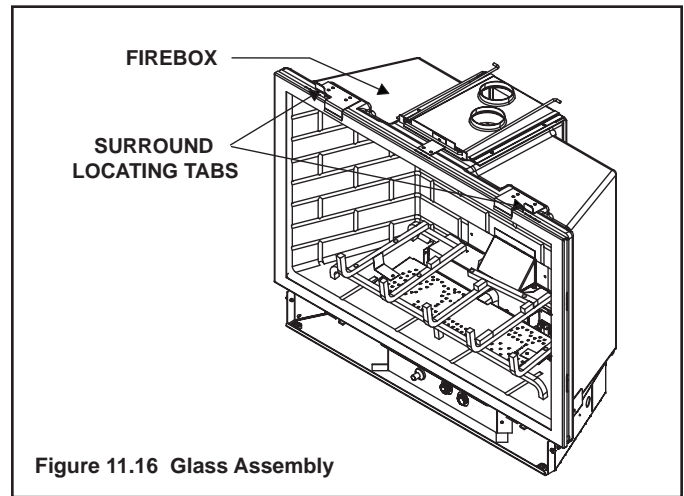

Figure 11.16 Glass Assembly

## G. Air Shutter Setting

Optimal flame appearance is dependent on the air shutter setting. Adjustments should be made by a qualified technician.

	<b>NG</b>	<b>LP</b>
FB-GRAND-S	Full open	Full open
FB-IN-S	1/2 in.	Full open



# 12 Operating Instructions



## A. Before Lighting Appliance

This appliance has a Standing Pilot Ignition.

**Before operating this appliance have a qualified technician:**

- Remove all shipping materials from inside and/or underneath the firebox.
- Review proper placement of logs, rockwool, lava rock, and vermiculite.
- Check the wiring.
- Check the air shutter adjustment.
- Purge gas line (with glass assembly removed). See Section 8.
- Ensure that there are no gas leaks.
- Ensure that the glass is sealed and in the proper position.
- Ensure that the flow of combustion and ventilation air is not obstructed (front grilles and vent caps).

 <b>WARNING</b>	
	<p>Fire Risk. Explosion Risk. Gas may build up while lighting pilot.</p> <ul style="list-style-type: none"><li>• Remove glass assembly before lighting pilot.</li><li>• Replace glass assembly after lighting pilot.</li></ul>
	

 <b>WARNING</b>	
	<p><b>HOT SURFACES!</b> Glass and other surfaces are hot during operation AND cool down.</p> <p><b>Hot glass will cause burns.</b></p> <ul style="list-style-type: none"><li>• <b>DO NOT</b> touch glass until it is cooled</li><li>• <b>NEVER</b> allow children to touch glass</li><li>• Keep children away</li></ul> <ul style="list-style-type: none"><li>• <b>CAREFULLY SUPERVISE</b> children in same room as fireplace.</li><li>• Alert children and adults to hazards of high temperatures.</li></ul> <p><b>High temperatures may ignite clothing or other flammable materials.</b></p> <ul style="list-style-type: none"><li>• Keep clothing, furniture, draperies and other flammable materials away.</li></ul> <hr/> <p><i><b>This appliance has been supplied with an integral barrier to prevent direct contact with the fixed glass panel. DO NOT operate the appliance with the barrier removed.</b></i></p> <p>Contact your dealer or Hearth &amp; Home Technologies if the barrier is not present or help is needed to properly install one.</p>

 <b>WARNING</b>	
<p>Improper installation, adjustment, alteration, service or maintenance can cause injury or property damage. Refer to the owner's information manual provided with this appliance. For assistance or additional information consult a qualified installer, service agency or the gas supplier.</p>	

 <b>WARNING</b>	
<p>Do NOT use this appliance if any part has been under water. Immediately call a qualified service technician to inspect the appliance and to replace any part of the control system and any gas control which has been under water.</p>	

## B. Lighting Appliance

### Standing Pilot Ignition

# FOR YOUR SAFETY READ BEFORE LIGHTING

**WARNING:** If you do not follow these instructions exactly, a fire or explosion may result causing property damage, personal injury or loss of life.

- A.** This appliance has a pilot which must be lighted by hand. When lighting the pilot, follow these instructions exactly.
- B. BEFORE LIGHTING**, smell all around the appliance area for gas. Be sure to smell next to the floor because some gas is heavier than air and will settle on the floor.
- WHAT TO DO IF YOU SMELL GAS**
- Do not try to light any appliance.
  - Do not touch any electric switch; do not use any phone in your building.
  - Immediately call your gas supplier from a neighbor's phone. Follow the gas supplier's instructions.
- C.** If you cannot reach your gas supplier, call the fire department.
- C.** Use only your hand to push in or turn the gas control knob. Never use tools. If the knob will not push in or turn by hand, don't try to repair it, call a qualified service technician. Force or attempted repair may result in a fire or explosion.
- D.** Do not use this appliance if any part has been under water. Immediately call a qualified service technician to inspect the appliance and to replace any part of the control system and any gas control which has been under water.

## WARNING:

### DO NOT CONNECT 110 VAC TO THE CONTROL VALVE.

Improper installation, adjustment, alteration, service or maintenance can cause injury or property damage. Refer to the owner's information manual provided with this appliance.

This appliance needs fresh air for safe operation and must be installed so there are provisions for adequate combustion and ventilation air.

If not installed, operated, and maintained in accordance with the manufacturer's instructions, this product could expose you to substances in fuel or fuel combustion which are known to the State of California to cause cancer, birth defects, or other reproductive harm.

Keep burner and control compartment clean. See installation and operating instructions accompanying appliance.

For additional information on operating your Hearth & Home Technologies fireplace, please refer to [www.fireplaces.com](http://www.fireplaces.com).

## CAUTION:

Hot while in operation. Do not touch. Keep children, clothing, furniture, gas-line and other liquids having flammable vapors away.

Do not operate the appliance with panel(s) removed, cracked or broken. Replacement of the panel(s) should be done by a licensed or qualified service person.

## NOT FOR USE WITH SOLID FUEL

For use with natural gas and propane. A conversion kit, as supplied by the manufacturer, shall be used to convert this appliance to the alternate fuel.

**Also Certified for Installation in a Bedroom or a Bedsitting Room.**

For assistance or additional information, consult a qualified installer, service agency or the gas supplier.

# LIGHTING INSTRUCTIONS

1. Turn off all electric power to the appliance.

2. Push in gas control knob slightly and turn clockwise to "OFF".

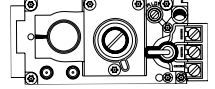

**NOTE:** Knob cannot be turned from "PILOT" to "OFF" unless knob is pushed in slightly. Do not force.

3. Wait five (5) minutes to clear out any gas. Then smell for gas, including near the floor. If you smell gas, STOP! Follow "B" in the Safety Information located on the left side of this label. If you don't smell gas, go to next step.

4. Find the pilot. The pilot is inside combustion chamber next to the main burner.

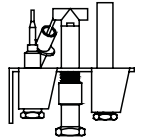

5. Turn knob on gas control counter clockwise to "PILOT".

6. Push in control knob all the way and hold in. Immediately depress red or black piezo button. It may require several depressions of the red or black piezo button until PILOT lights. If PILOT light does not light after 10 seconds, return to step 3. Continue to hold the control knob in for about one minute after the pilot is lit. Release knob and it will pop back out. Pilot should remain lit. If it goes out, repeat steps 3 through 6.

- If knob does not pop up when released, stop and immediately call your service technician or gas supplier.
- If the pilot will not stay lit after several tries, turn the gas control knob to "OFF" and call your service technician or gas supplier.

7. Turn gas control knob counterclockwise to "ON".

8. To light Burner, flip the on/off switch to the "ON" position, and close access grille.

9. Turn on all electric power to the appliance.

# TO TURN OFF GAS TO APPLIANCE

1. Turn off all electric power to the appliance if service is to be performed.
2. Open control access panel.
3. Move switch to "OFF" position.
4. Push in gas control knob slightly and turn clockwise to "OFF". Do not force.
5. Close control access panel.

464-903G

## C. Check Pilot Flame Appearance

Pilot flame must contact the thermocouple and thermopile for reliable appliance operation.

- Pilot flame should be as shown in Figure 12.1.

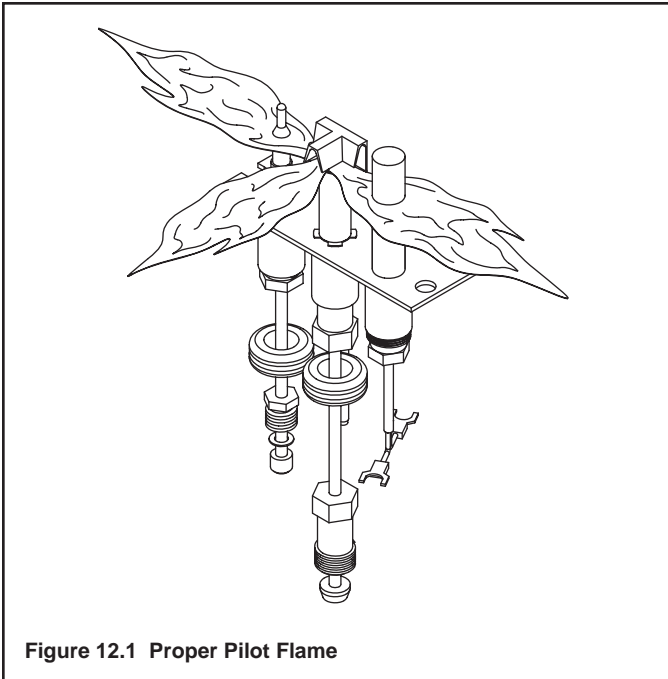

Figure 12.1 Proper Pilot Flame

- If adjustment is needed remove cap screw from gas valve using 1/8 inch standard screwdriver (see Figure 12.2.)
- Turn adjustment screw clockwise to increase pilot flame size. Make small adjustments.

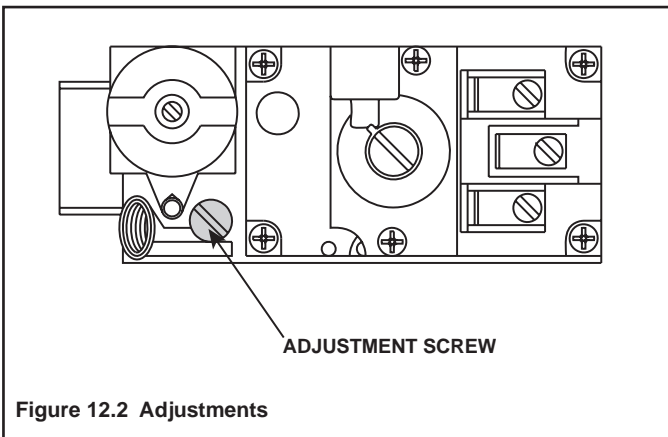

Figure 12.2 Adjustments

- Do **NOT** turn adjustment screw counter-clockwise too far as it will come out of the valve allowing gas to escape.
- Replace cap screw and seal to prevent gas leaks.
- Check for gas leaks after tightening.

## D. After Appliance is Lit

	<b>WARNING</b>
	Glass door must be in place when appliance is operating. Risk of: <ul style="list-style-type: none"><li>• Combustion Fumes</li><li>• Fire</li></ul> Do NOT operate appliance with glass door removed. <ul style="list-style-type: none"><li>• Open viewing glass for servicing only.</li></ul>
	<ul style="list-style-type: none"><li>• Glass door <b>MUST</b> be in place and sealed before operating appliance.</li><li>• Only use glass door certified for use with appliance.</li><li>• Glass replacement should be done by qualified technician.</li></ul>

### Initial Break-in Procedure

When you light the appliance, you may notice that it produces heat which does have an associated odor or smell. If you feel this odor is excessive it may require the initial three to four hour continuous burn on high followed by a second burn up to 12 hours to fully drive off any odor from paint and lubricants used in the manufacturing process. Condensation of the glass is normal.

**Note:** The appliance should be run three to four hours on the initial start-up. Turn it off and let it cool completely. Remove and clean the glass. Replace the glass and run the appliance for an additional 12 hours. This will help to cure the products used in the paint and logs.

During this break-in period it is recommended that some windows in the house be opened for air circulation. This will help avoid setting off smoke detectors, and help eliminate any odors associated with the appliance's initial burning.

### **WARNING**



- Fire Risk.  
High Temperatures.  
Keep combustible household items away from appliance.  
Do NOT obstruct combustion and ventilation air.
- Do NOT place combustible items on top of or in front of appliance.
  - Keep furniture, draperies away from appliance.

### **CAUTION**

- Prevent accidental appliance operation when not attended.
- Unplug or remove batteries from remote control if absent or if appliance will not be used for an extended period of time.
- Property damage possible from elevated temperatures.

### **CAUTION**

- Smoke and odors released during initial operation.
- Open windows for air circulation.
  - Leave room during initial operation.
  - Smoke may set off smoke detectors.
- Smoke and odors may be irritating to sensitive individuals.

### **WARNING**



- Fire Hazard.
- Keep combustible materials, gasoline and other flammable vapors and liquids clear of appliance.
- Do NOT store flammable materials in the appliance's vicinity.
  - Do NOT use gasoline, lantern fuel, kerosene, charcoal lighter fluid or similar liquids in this appliance.
  - Combustible materials may ignite.

## E. Frequently Asked Questions

ISSUE	SOLUTIONS
Condensation on the glass	This is a result of gas combustion and temperature variations. As the appliance warms, this condensation will disappear.
Blue flames	This is a result of normal operation and the flames will begin to yellow as the appliance is allowed to burn for 20 to 40 minutes.
Odor from appliance	When first operated, this appliance may release an odor for the first several hours. This is caused by the curing of the paint and the burning off of any oils remaining from manufacturing and might set off home smoke detectors.
Film on the glass	This is a normal result of the curing process of the paint and logs. Glass should be cleaned within 3 to 4 hours of initial burning to remove deposits left by oils from the manufacturing process. A non-abrasive cleaner such as gas fireplace glass cleaner may be necessary. See your dealer.
Metallic noise	Noise is caused by metal expanding and contracting as it heats up and cools down, similar to the sound produced by a furnace or heating duct. This noise does not affect the operation or longevity of the appliance.
Is it normal to see the pilot flame burn continually?	In a standing pilot system the pilot will always stay on.

# 13 Troubleshooting

With proper installation, operation, and maintenance your gas appliance will provide years of trouble-free service. If you do experience a problem, this troubleshooting guide will assist a qualified service person in the diagnosis of a problem and the corrective action to be taken. This troubleshooting guide can only be used by a qualified service technician.

## A. Standing Pilot Ignition System

Symptom	Possible Causes	Corrective Action
1. After repeated triggering of the red or black piezo ignitor button, the spark ignitor will not light the pilot.	a. Defective ignitor.	Check the spark at the electrode and pilot. If no spark and electrode wire is properly connected, replace the ignitor.
	b. Defective pilot or misaligned electrode (spark at electrode).	Using match, light the pilot. If the pilot lights, turn off the pilot and trigger the red piezo ignitor button again. If the pilot lights, an improper gas/air mixture caused the bad lighting and a longer purge period is recommended. If the pilot will not light, ensure the gap at the electrode and pilot is one-eighth (1/8) inch to have a strong spark. If the gap is OK, replace the pilot.
	c. No gas or low gas pressure.	Check the remote shut-off valves from the fireplace. Usually, there is a valve near the gas main. There can be more than one (1) valve between the fireplace and the main.
	d. No LP in tank.	Check the LP (propane) tank. You may be out of fuel.
2. The pilot will not stay lit after carefully following the lighting instructions.	a. Defective thermocouple.	Check that the pilot flame impinges on the thermocouple. Clean and/or adjust the pilot for maximum flame impingement.  Ensure that the thermocouple connection at the gas valve is fully inserted and tight (hand tighten plus 1/4 turn).  Disconnect the thermocouple from the valve, place one millivolt meter lead wire on the tip of the thermocouple and the other meter lead wire on the thermocouple copper lead. Start the pilot and hold the valve knob in. If the millivolt reading is less than 15mV, replace the thermocouple.
	b. Defective valve.	If the thermocouple is producing more than 15 millivolts, replace faulty valve.
3. The pilot is burning, there is no burner flame, the valve knob is in the ON position, and the ON/OFF switch is in the ON position.	a. ON/OFF switch or wires defective.	Check the ON/OFF switch and wires for proper connections. Place the jumper wires across the terminals at the switch. If the burner comes on, replace the defective switch. If the switch is OK, place the jumper wires across the switch wires at the gas valve. If the burner comes on, the wires are faulty or connections are bad.
	b. Thermopile may not be generating sufficient millivoltage.	If the pilot flame is not close enough physically to the thermopile, adjust the pilot flame.  Be sure the wire connections from the thermopile at the gas valve terminals are tight and that the thermopile is fully inserted into the pilot bracket.  Check the thermopile with a millivolt meter. Take the reading at TH-TP&TP terminals of the gas valve. The meter should read 325 millivolts minimum, while holding the valve knob depressed in the pilot position, with the pilot lit, and the ON/OFF switch in the OFF position. Replace the faulty thermopile if the reading is below the specified minimum.  With the pilot in the ON position, disconnect the thermopile leads from the valve. Take a reading at the thermopile leads. The reading should be 325 millivolts minimum. Replace the thermopile if the reading is below the minimum.



## Troubleshooting (continued)

Symptom	Possible Cause	Corrective Action
3. Continued	c. Defective valve.	Turn the valve knob to the ON position. Place the ON/OFF switch in the ON position. Check the millivolt meter at the thermopile terminals. The millivolt meter should read greater than 125mV. If the reading is acceptable, and if the burner does not come on, replace the gas valve.
	d. Plugged burner orifice.	Check the burner orifice for stoppage. Remove stoppage.
	e. Wall switch or wires are defective.	Follow the corrective action in Symptom and Possible Cause 1.a above. Check the switch and wiring. Replace where defective.
4. Frequent pilot outage problem.	a. Pilot flame may be too high or too low, or blowing out (high pressure), causing pilot safety to drop out.	Clean thermocouple and adjust the pilot flame for maximum flame impingement. Follow lighting instructions carefully.
5. The pilot and main burner extinguish while in operation.	a. No LP in tank.	Check the LP (propane) tank. Refill the fuel tank.
	b. Inner vent pipe leaking exhaust gases back into the system.	Check venting system for damage. Replace/repair improperly assembled pipe sections.
	c. Glass too loose and air tight packet leaks in corners after usage.	Replace glass panel assembly.
	d. Bad thermopile or thermocouple.	Replace if necessary.
	e. Improper vent cap installation.	Check for proper installation and freedom from debris or blockage.
6. Glass soots.	a. Flame impingement.	Adjust the log set so that the flame does not excessively impinge on it.
	b. Improper air shutter setting.	Adjust the air shutter located on the control panel.
	c. Debris around air shutter.	Inspect the opening at the base of the burner. NO MATERIAL SHOULD BE PLACED IN THIS OPENING.
7. Flame burns blue and lifts off burner.	a. Insufficient oxygen being supplied.	Ensure that the vent cap is installed properly and free of debris. Ensure that the vent system joints are tight and have no leaks.  Ensure that no debris has been placed at the base of, or in the area of the air holes in the center of the base pan beneath the burner.  Ensure that the glass is tightened properly on the unit, particularly on top corners.

# 14 Maintaining and Servicing Appliance

## A. Maintenance Tasks

Although the frequency of appliance servicing and maintenance will depend on use and the type of installation, a qualified service technician should perform an appliance checkup at the beginning of each heating season.

### WARNING

Risk of injury or property damage.

#### Before servicing:

- Turn off gas.
- Turn off electricity to appliance.
- Disable remote control, if one is present.
- Ensure appliance is completely cooled.

#### After servicing:

- Replace any screen or barrier that was removed.
- Reseal and reinstall any venting removed for servicing.

### WARNING

Annual inspection by qualified technician recommended.

#### Check:

- Condition of doors, surrounds and fronts.
- Condition of glass, glass assembly and glass seal.
- Obstructions of combustion and ventilation air.
- Condition of logs.
- Condition of firebox.
- Burner ignition and operation.
- Burner air shutter adjustment
- Gas connections and fittings.
- Obstructions of termination cap.

#### Clean:

- Glass
- Air passageways, grilles, control compartment
- Burner, burner ports

#### Risk of:

- Fire
- Delayed ignition or explosion
- Exposure to combustion fumes
- Odors



### CAUTION



Handle glass assembly with care.

**NOTE:** Clean glass after initial 3-4 hours operation. **Longer operation without cleaning glass may cause a permanent white film on glass.**

#### When cleaning glass door:

- Avoid striking, scratching or slamming glass.
- Do NOT use abrasive cleaners.
- Use a hard water deposit glass cleaner on white film.
- Do NOT clean glass when hot.
- Turn off appliance after 3-4 hours of operation and **ALLOW TO COOL.**
- Remove and clean glass assembly.
- Replace glass assembly and operate appliance for additional 12 hours.

Refer to maintenance instructions.

### WARNING



Inspect external vent cap regularly.

- Ensure no debris blocks cap.

- Combustible materials blocking cap may ignite.
- Restricted air flow affects burner operation.



Inspect	Maintenance Tasks
Doors, Surrounds and Fronts	1. Assess condition of screen and replace as necessary. Recommend addition of screen if one is not present.
	2. Inspect for scratches, dents or other damage and repair as necessary.
	3. Verify no obstructions to airflow through the louvers.
	4. Verify maintenance of proper clearance to combustible household objects.
Gasket Seal, Glass Assembly and Glass	1. Inspect gasket seal and its condition.
	2. Inspect glass panels for scratches and nicks that can lead to breakage when exposed to heat.
	3. Confirm there is no damage to glass or glass frame. Replace as necessary.
	4. Verify that latches engage properly, clip studs are not stripped, and glass attachment components are intact and operating properly. Replace as necessary.
	5. Clean glass. Replace glass assembly if severely coated with silicate deposits that cannot be removed.
Valve Compartment and Firebox Top	1. Vacuum and wipe out dust, cobwebs, debris or pet hair. Use caution when cleaning these areas. Screw tips that have penetrated the sheet metal are sharp and should be avoided.
	2. Remove any foreign objects.
	3. Verify unobstructed air circulation.
Logs	1. Inspect for broken, damaged, or missing logs. Replace as necessary.
	2. Verify correct log placement and no flame impingement causing sooting. Correct as necessary.
Firebox	1. Inspect for paint condition, warpage, corrosion or perforation. Contact Dealer for inspection.
	2. Replace appliance if firebox has been perforated.
Burner Ignition and Operation	1. Verify burner is properly secured and aligned with pilot or igniter.
	2. Clean off burner top, inspect for plugged ports, corrosion or deterioration. Replace burner if necessary.
	3. Replace ember materials with new dime-size and shape pieces. Do not block ports or obstruct lighting paths.
	4. Check for smooth lighting and ignition carryover to all ports. Verify there is no ignition delay.
	5. Inspect for lifting or other flame problems.
	6. Verify air shutter is clear of dust and debris.
	7. Inspect orifice for soot, dirt or corrosion.
	8. Verify manifold and inlet pressures. Adjust regulator as required.
	9. Inspect pilot flame strength. Clean or replace orifice as necessary.
	10. Inspect thermocouple/thermopile or IPI sensor rod for soot, corrosion and deterioration. Clean with emery cloth or replace as required.
	11. Verify millivolt output. Replace as necessary.
Venting	1. Inspect venting for blockage or obstruction such as bird nests, leaves, etc.
	2. Confirm that termination cap remains clear and unobstructed by plants, etc.
	3. Verify that termination cap clearance to subsequent construction (building additions, decks, fences or sheds) has been maintained.
	4. Inspect for corrosion or separation.
	5. Verify weather stripping, sealing and flashing remains intact.
	6. Inspect draft shield to verify it is not bent, damaged or missing.
Remote controls	1. Verify operation of remote.
	2. Replace batteries in remote transmitters and battery-powered receivers.
	3. Verify batteries have been removed from battery back-up IPI systems to prevent premature battery failure or leaking.

# 15 Reference Materials

## A. Appliance Dimension Diagram

Dimensions are actual appliance dimensions. Use for reference only. For framing dimensions and clearances refer to Section 3.

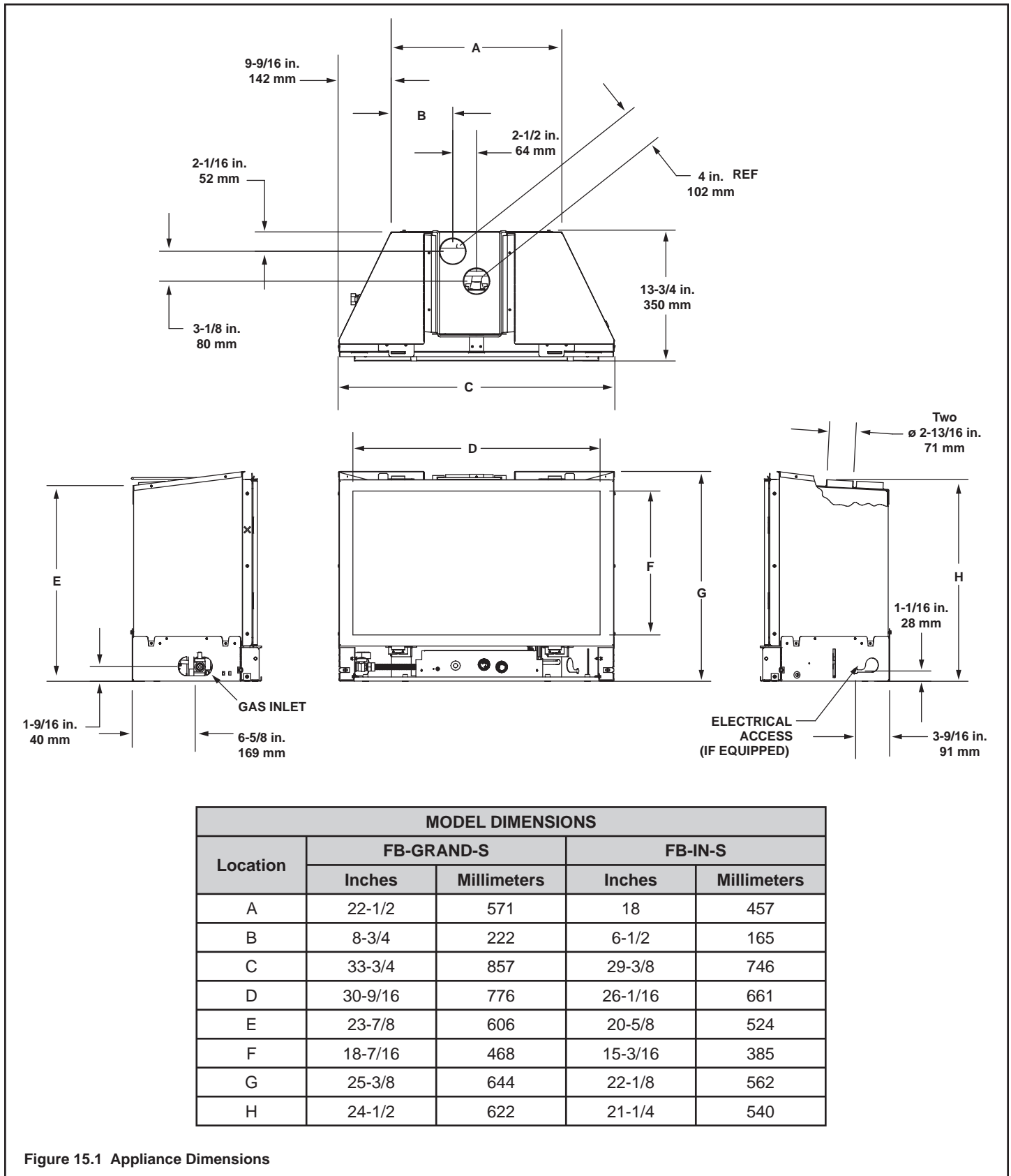

Figure 15.1 Appliance Dimensions

## B. Vent Kits Components

Direct Vent Flex Liner Kits (see Figure 15.2)

LINK-DV-30B or (LINK-DV-30): Masonry 3 inch flex liner kit. Expands to 30 feet. Includes: two liners, termination cap, flashing, and link adapter.

LINK-DV4-30B or (LINK-DV4-30): Masonry 3 inch flex liner kit. Expands to 30 feet and 4 feet respectively. Includes: two liners, termination cap, flashing, and link adapter.

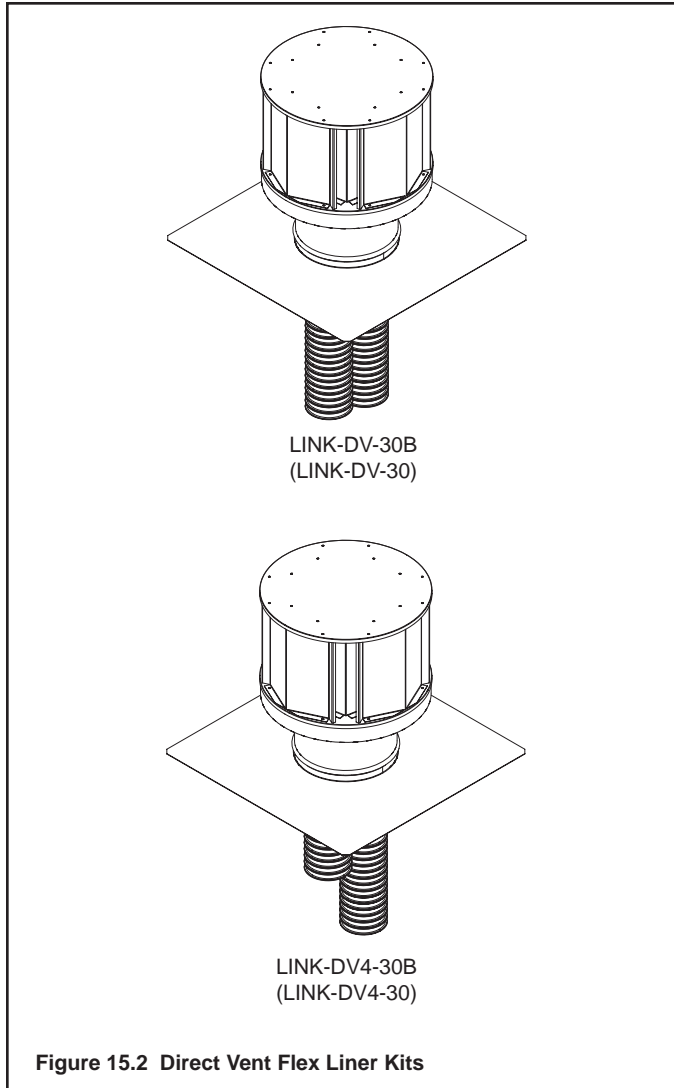

### Direct Vent Flex Liner Accessory Kits

(see Figure 15.3)

Flash-Damp: Zero clearance damper flashing kit for use with LINK-DV-30B or LINK-DV4-30B liner kits.

LINK-ZC-ADP: Zero clearance chimney adapter

SVRLINK-ADP: Adapter kit (colinear to coaxial 3 inches included in above kits).

FLEX3-30: One 3 inch flexible liner expands to 30 feet.

FLEX3-30/2: Two 3 inch flexible liners expands to 30 feet each.

FLEX-CNCT: Connector kit - 3 inch liner to 3 inch liner, one connector per kit.

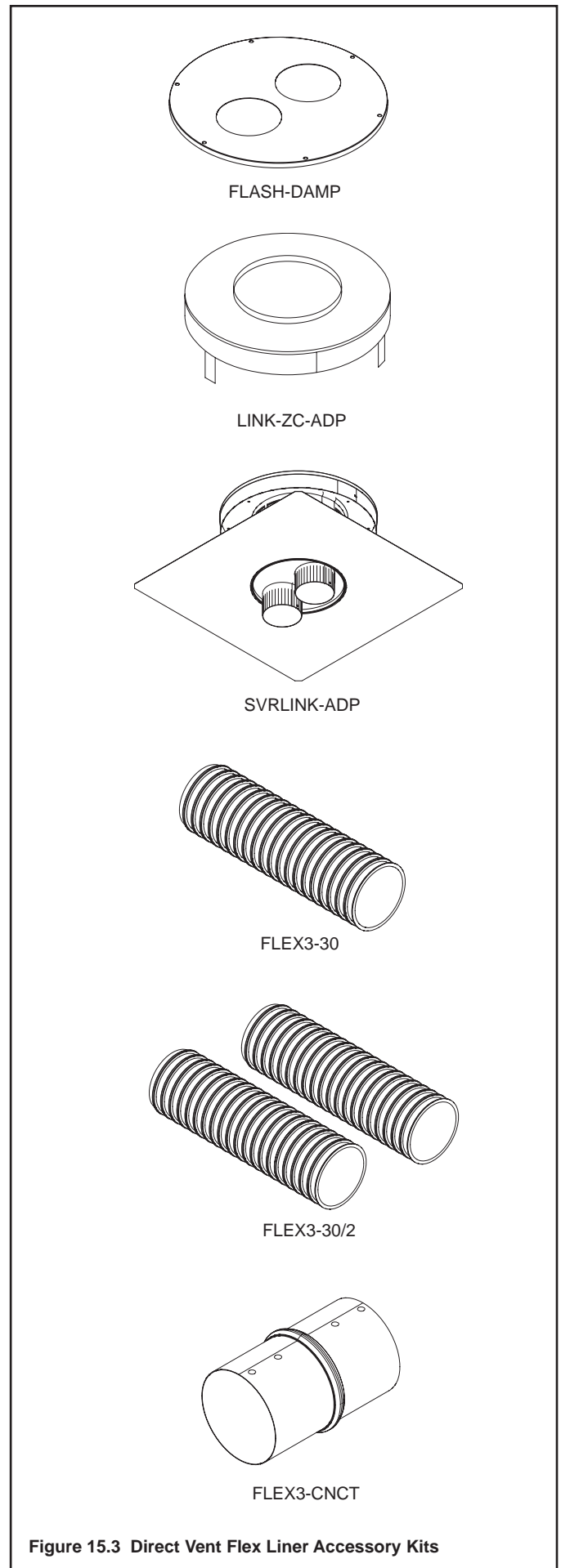

## D. Limited Lifetime Warranty

### Hearth & Home Technologies Inc. LIMITED LIFETIME WARRANTY

Hearth & Home Technologies Inc., on behalf of its hearth brands ("HHT"), extends the following warranty for HHT gas, wood, pellet, coal and electric hearth appliances that are purchased from an HHT authorized dealer.

#### **WARRANTY COVERAGE:**

HHT warrants to the original owner of the HHT appliance at the site of installation, and to any transferee taking ownership of the appliance at the site of installation within two years following the date of original purchase, that the HHT appliance will be free from defects in materials and workmanship at the time of manufacture. After installation, if covered components manufactured by HHT are found to be defective in materials or workmanship during the applicable warranty period, HHT will, at its option, repair or replace the covered components. HHT, at its own discretion, may fully discharge all of its obligations under such warranties by replacing the product itself or refunding the verified purchase price of the product itself. The maximum amount recoverable under this warranty is limited to the purchase price of the product. This warranty is subject to conditions, exclusions and limitations as described below.

#### **WARRANTY PERIOD:**

Warranty coverage begins on the date of installation. In the case of new home construction, warranty coverage begins on the date of first occupancy of the dwelling or six months after the sale of the product by an independent, authorized HHT dealer/ distributor, whichever occurs earlier. The warranty shall commence no later than 24 months following the date of product shipment from HHT, regardless of the installation or occupancy date. The warranty period for parts and labor for covered components is produced in the following table.

The term "Limited Lifetime" in the table below is defined as: 20 years from the beginning date of warranty coverage for gas appliances, and 10 years from the beginning date of warranty coverage for wood, pellet, and coal appliances. These time periods reflect the minimum expected useful lives of the designated components under normal operating conditions.

Warranty Period		HHT Manufactured Appliances and Venting							Components Covered
Parts	Labor	Gas	Wood	Pellet	EPA Wood	Coal	Electric	Venting	
1 Year		X	X	X	X	X	X	X	All parts and material except as covered by Conditions, Exclusions, and Limitations listed
2 years				X	X	X			Igniters, electronic components, and glass
		X	X	X	X	X			Factory-installed blowers
			X						Molded refractory panels
3 years				X					Firepots and burnpots
5 years	1 year			X	X				Castings and baffles
7 years	3 years		X	X	X				Manifold tubes, HHT chimney and termination
10 years	1 year	X							Burners, logs and refractory
Limited Lifetime	3 years	X	X	X	X	X			Firebox and heat exchanger
90 Days		X	X	X	X	X	X	X	All replacement parts beyond warranty period

See conditions, exclusions, and limitations on next page.

## **D. Limited Lifetime Warranty (*continued*)**

### **WARRANTY CONDITIONS:**

- This warranty only covers HHT appliances that are purchased through an HHT authorized dealer or distributor. A list of HHT authorized dealers is available on the HHT branded websites.
- This warranty is only valid while the HHT appliance remains at the site of original installation.
- Contact your installing dealer for warranty service. If the installing dealer is unable to provide necessary parts, contact the nearest HHT authorized dealer or supplier. Additional service fees may apply if you are seeking warranty service from a dealer other than the dealer from whom you originally purchased the product.
- Check with your dealer in advance for any costs to you when arranging a warranty call. Travel and shipping charges for parts are not covered by this warranty.

### **WARRANTY EXCLUSIONS:**

This warranty does not cover the following:

- Changes in surface finishes as a result of normal use. As a heating appliance, some changes in color of interior and exterior surface finishes may occur. This is not a flaw and is not covered under warranty.
- Damage to printed, plated, or enameled surfaces caused by fingerprints, accidents, misuse, scratches, melted items, or other external sources and residues left on the plated surfaces from the use of abrasive cleaners or polishes.
- Repair or replacement of parts that are subject to normal wear and tear during the warranty period. These parts include: paint, wood, pellet and coal gaskets; firebricks; grates; flame guides; and the discoloration of glass.
- Minor expansion, contraction, or movement of certain parts causing noise. These conditions are normal and complaints related to this noise are not covered by this warranty.
- Damages resulting from: (1) failure to install, operate, or maintain the appliance in accordance with the installation instructions, operating instructions, and listing agent identification label furnished with the appliance; (2) failure to install the appliance in accordance with local building codes; (3) shipping or improper handling; (4) improper operation, abuse, misuse, continued operation with damaged, corroded or failed components, accident, or improperly/incorrectly performed repairs; (5) environmental conditions, inadequate ventilation, negative pressure, or drafting caused by tightly sealed constructions, insufficient make-up air supply, or handling devices such as exhaust fans or forced air furnaces or other such causes; (6) use of fuels other than those specified in the operating instructions; (7) installation or use of components not supplied with the appliance or any other components not expressly authorized and approved by HHT; (8) modification of the appliance not expressly authorized and approved by HHT in writing; and/or (9) interruptions or fluctuations of electrical power supply to the appliance.
- Non-HHT venting components, hearth components or other accessories used in conjunction with the appliance.
- Any part of a pre-existing fireplace system in which an insert or a decorative gas appliance is installed.
- HHT's obligation under this warranty does not extend to the appliance's capability to heat the desired space. Information is provided to assist the consumer and the dealer in selecting the proper appliance for the application. Consideration must be given to appliance location and configuration, environmental conditions, insulation and air tightness of the structure.

### **This warranty is void if:**

- The appliance has been over-fired or operated in atmospheres contaminated by chlorine, fluorine, or other damaging chemicals. Over-firing can be identified by, but not limited to, warped plates or tubes, rust colored cast iron, bubbling, cracking and discoloration of steel or enamel finishes.
- The appliance is subjected to prolonged periods of dampness or condensation.
- There is any damage to the appliance or other components due to water or weather damage which is the result of, but not limited to, improper chimney or venting installation.

### **LIMITATIONS OF LIABILITY:**

- The owner's exclusive remedy and HHT's sole obligation under this warranty, under any other warranty, express or implied, or in contract, tort or otherwise, shall be limited to replacement, repair, or refund, as specified above. In no event will HHT be liable for any incidental or consequential damages caused by defects in the appliance. Some states do not allow exclusions or limitation of incidental or consequential damages, so these limitations may not apply to you. This warranty gives you specific rights; you may also have other rights, which vary from state to state. EXCEPT TO THE EXTENT PROVIDED BY LAW, HHT MAKES NO EXPRESS WARRANTIES OTHER THAN THE WARRANTY SPECIFIED HEREIN. THE DURATION OF ANY IMPLIED WARRANTY IS LIMITED TO DURATION OF THE EXPRESSED WARRANTY SPECIFIED ABOVE.

**E. Contact Information**



No one builds a better fire

Heat & Glo, a brand of Hearth & Home Technologies Inc.  
7571 215th Street West, Lakeville, MN 55044  
www.heatnglo.com

Please contact your Heat & Glo dealer with any questions or concerns.  
For the location of your nearest Heat & Glo dealer,  
please visit [www.heatnglo.com](http://www.heatnglo.com).

**- NOTES -**

---

---

---

---

---

---

---

---

---

---

---

---

<b>CAUTION</b>			
<b>DO NOT DISCARD THIS MANUAL</b>			
	<ul style="list-style-type: none"><li>• Important operating and maintenance instructions included.</li></ul>	<ul style="list-style-type: none"><li>• Read, understand and follow these instructions for safe installation and operation.</li><li>• Leave this manual with party responsible for use and operation.</li></ul>	

This product may be covered by one or more of the following patents: (United States) 4593510, 4686807, 4766876, 4793322, 4811534, 5000162, 5016609, 5076254, 5113843, 5191877, 5218953, 5263471, 5328356, 5341794, 5347983, 5429495, 5452708, 5542407, 5601073, 5613487, 5647340, 5688568, 5762062, 5775408, 5890485, 5931661, 5941237, 5947112, 5996575, 6006743, 6019099, 6048195, 6053165, 6145502, 6170481, 6237588, 6296474, 6374822, 6413079, 6439226, 6484712, 6543698, 6550687, 6601579, 6672860, 6688302B2, 6715724B2, 6729551, 6736133, 6748940, 6748942, 6769426, 6774802, 6796302, 6840261, 6848441, 6863064, 6866205, 6869278, 6875012, 6880275, 6908039, 6919884, D320652, D445174, D462436; (Canada) 1297749, 2195264, 2225408, 2313972; (Australia) 780250, 780403, 1418504 or other U.S. and foreign patents pending.

Printed in U.S.A. - Copyright 2009