

**Models:
Olympus
Titan**

Installers Guide

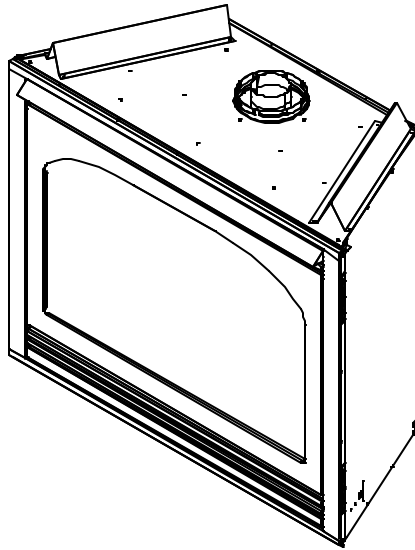

Underwriters
Laboratories Listed

WARNING: IF THE INFORMATION IN THESE INSTRUCTIONS IS NOT FOLLOWED EXACTLY, A FIRE OR EXPLOSION MAY RESULT CAUSING PROPERTY DAMAGE, PERSONAL INJURY, OR DEATH.

- Do not store or use gasoline or other flammable vapors and liquids in the vicinity of this or any other appliance.
- **What to do if you smell gas**
 - Do not try to light any appliance.
 - Do not touch any electrical switch.
 - Do not use any phone in your building.
 - Immediately call your gas supplier from a neighbor's phone. Follow the gas supplier's instructions.
 - If you cannot reach your gas supplier, call the fire department.
- Installation and service must be performed by a qualified installer, service agency, or the gas supplier.

READ THIS MANUAL BEFORE INSTALLING OR OPERATING THIS APPLIANCE. THIS *INSTALLERS GUIDE* MUST BE LEFT WITH APPLIANCE FOR FUTURE REFERENCE.

WARNING: IMPROPER INSTALLATION, ADJUSTMENT, ALTERATION, SERVICE OR MAINTENANCE CAN CAUSE INJURY OR PROPERTY DAMAGE. REFER TO THIS MANUAL. FOR ASSISTANCE OR ADDITIONAL INFORMATION CONSULT A QUALIFIED INSTALLER, SERVICE AGENCY, OR THE GAS SUPPLIER.

1. This appliance may be installed in an aftermarket, permanently located, manufactured (mobile) home, where not prohibited by local codes.
2. This appliance is only for use with the type of gas indicated on the rating plate. This appliance is not convertible for use with other gases, unless a certified kit is used.

Printed in U.S.A. Copyright 2004
 Hearth & Home Technologies, Inc.
 20802 Kensington Boulevard, Lakeville, MN 55044

Please contact your Hearth & Home Technologies dealer with any questions or concerns. For the number of your nearest Hearth & Home Technologies dealer, please call (Olympus) 1-888-427-3973 or (Titan) 1-800-927-6841.

SAFETY AND WARNING INFORMATION

 **READ** and **UNDERSTAND** all instructions carefully before starting the installation. **FAILURE TO FOLLOW** these installation instructions may result in a possible fire hazard and will void the warranty.

 Prior to the first firing of the fireplace, **READ** the Lighting the Fireplace section of the *Installer's Guide*.

 **DO NOT USE** this appliance if any part has been under water. Immediately **CALL** a qualified service technician to inspect the unit and to replace any part of the control system and any gas control which has been under water.

 **THIS UNIT IS NOT FOR USE WITH SOLID FUEL.**

 Installation and repair should be **PERFORMED** by a qualified service person. The appliance and venting system should be **INSPECTED** before initial use and at least annually by a professional service person. More frequent cleaning may be required due to excessive lint from carpeting, bedding material, etc. It is **IMPERATIVE** that the unit's control compartment, burners, and circulating air passageways **BE KEPT CLEAN** to provide for adequate combustion and ventilation air.

 Always **KEEP** the appliance clear and free from combustible materials, gasoline, and other flammable vapors and liquids.

 **NEVER OBSTRUCT** the flow of combustion and ventilation air. Keep the front of the appliance **CLEAR** of all obstacles and materials for servicing and proper operations.

 Due to the high temperature, the appliance should be **LOCATED** out of traffic areas and away from furniture and draperies. Clothing or flammable material **SHOULD NOT BE PLACED** on or near the appliance.

 Children and adults should be **ALERTED** to the hazards of high surface temperature and should **STAY AWAY** to avoid burns or clothing ignition. Young children should be **CAREFULLY SUPERVISED** when they are in the same room as the appliance.

 These units **MUST** use one of the vent systems described in the Installing the Fireplace section of the *Installers Guide*. **NO OTHER** vent systems or components **MAY BE USED**.

 This gas fireplace and vent assembly **MUST** be vented directly to the outside and **MUST NEVER** be attached to a chimney serving a separate solid fuel burning appliance. Each gas appliance **MUST USE** a separate vent system. Common vent systems are **PROHIBITED**.

 **INSPECT** the external vent cap on a regular basis to make sure that no debris is interfering with the air flow.

 The glass door assembly **MUST** be in place and sealed, and the trim door assembly **MUST** be in place on the fireplace before the unit can be placed into safe operation.

 **DO NOT OPERATE** this appliance with the glass door removed, cracked, or broken. Replacement of the glass door should be performed by a licensed or qualified service person. **DO NOT** strike or slam the glass door.

 The glass door assembly **SHALL ONLY** be replaced as a complete unit, as supplied by the gas fireplace manufacturer. **NO SUBSTITUTE** material may be used.

 **DO NOT USE** abrasive cleaners on the glass door assembly. **DO NOT ATTEMPT** to clean the glass door when it is hot.

 Turn off the gas before servicing this appliance. It is recommended that a qualified service technician perform an appliance check-up at the beginning of each heating season.

 Any safety screen or guard removed for servicing must be replaced before operating this appliance.

 **DO NOT** place furniture or any other combustible household objects within 36 inches of the fireplace front.

TABLE OF CONTENTS

Safety and Warning Information	2
◆ Service Parts Lists	4
Section 1: Approvals and Codes	10
Appliance Certification	10
Installation Codes	10
High Altitude Installations	10
Section 2: Getting Started	11
Introducing the Hearth & Home Technologies Gas Fireplaces	11
Pre-installation Preparation	11
Section 3: Installing the Fireplace	14
Step 1 Locating the Fireplace	14
Step 2 Framing the Fireplace	13
Step 3 Installing the Vent System	17
◆ A. Vent System Approvals	17
B. Installing Vent Components	21
◆ C. Vent Termination	22
Step 4 Positioning, Leveling, and Securing the Fireplace	25
Step 5 The Gas Control Systems	25
◆ Step 6 The Gas Supply Line	26
Step 7 Gas Pressure Requirements	26
◆ Step 8 Wiring the Fireplace	28
Step 9 Finishing	28
Step 10 Installing Trim, Refractory, Logs and Ember Material	28
Installing the Trim	28
Positioning the Refractory	28
Positioning the Logs	28
Placing the Ember Material	28
Glass Replacement	29
Step 11 Before Lighting the Fireplace	29
Step 12 Lighting the Fireplace	30
After the Installation	30
Section 4: Maintaining and Servicing Your Fireplace	31
Section 5: Troubleshooting	32

◆ = Contains updated information.

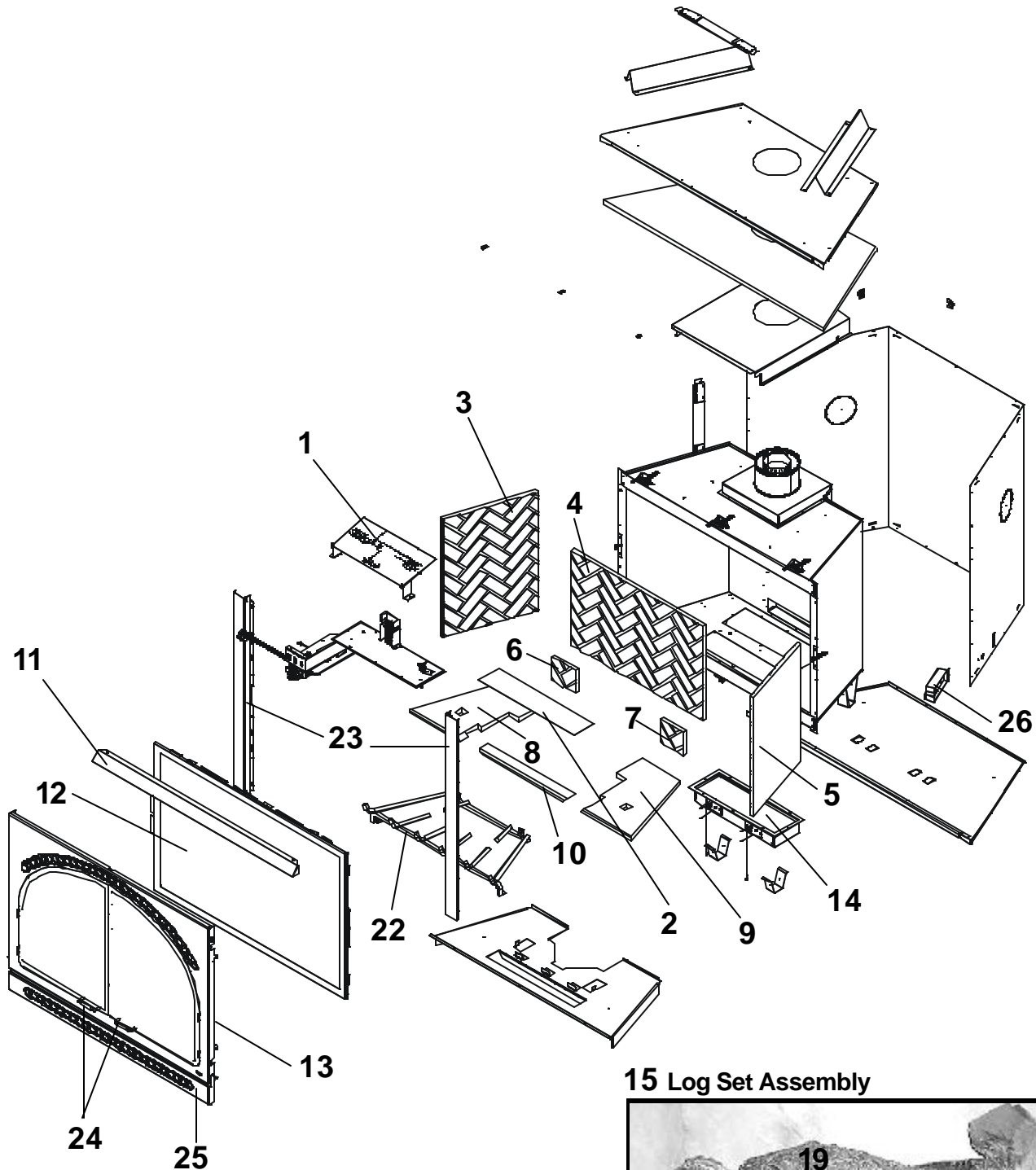

15 Log Set Assembly

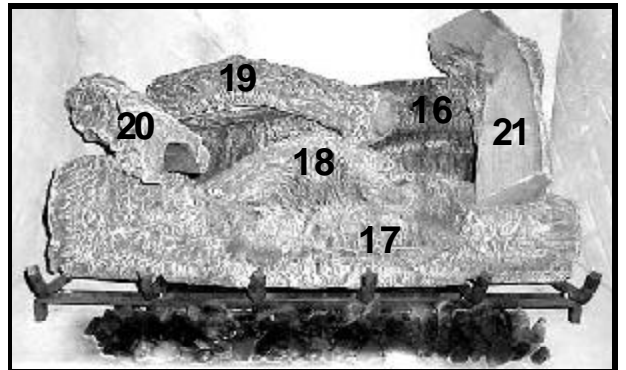

* Part number list on following page.
* La liste des numéros de pièce se trouve à la page suivante.

(NG, LP) Service Parts List / (GN, PL) Liste des pièces de rechange**TITAN**

IMPORTANT: THIS IS DATED INFORMATION. The most current information is located on your dealers VIP site. When ordering, supply serial and model numbers to ensure correct service parts. / **IMPORTANT :** L'information fournie dans cette brochure n'est valide que pendant une courte période. Les sites VIP des distributeurs disposent des renseignements les plus récents. Lors d'une commande, veuillez fournir les numéros de série et de modèles pour un remplacement adéquat des pièces.

ITEM / PIÈCE	IPI IGNITION / ALLUMAGE IPI	SERIAL # / N° DE SÉRIE	PART NUMBER / N° DE PIÈCE
1	Burner NG / Brûleur GN		781-175A
1	Burner LP / Brûleur PL		781-176A
2	Ember Mesh Screen / Écran		780-382
3	Refractory, Left Side / Réfractaire côté gauche		SRV781-735
4	Refractory, Back / Réfractaire arrière		SRV781-730
5	Refractory, Right Side / Réfractaire côté droit		SRV781-731
6	Refractory, Back Left / Réfractaire arrière gauche		SRV781-733
7	Refractory, Back Right / Réfractaire arrière droit		SRV781-734
8	Refractory, Left Base / Réfractaire Base gauche		SRV781-732
9	Refractory, Right Base / Réfractaire Base droit		SRV781-736
10	Refractory, Middle Base / Réfractaire Base		SRV781-737
11	Hood / Hotte		SRV570-143
12	Glass Door Assembly / Porte en verre		GLA-780
13	Decorative Front / Avant décoratif		DF-TITAN
14	Electric Ember Box / La Boîte Electrique de Braise		780-197A
15	Log Set Assembly / Jeu de Bûches		LOGS-TITAN
16	Log 1 / Bûche 1		SRV781-701
17	Log 2 / Bûche 2		SRV781-702
18	Log 3 / Bûche 3		SRV781-703
19	Log 4 / Bûche 4		SRV781-704
20	Log 5 / Bûche 5		SRV781-706
21	Log 6 / Bûche 6		SRV781-705
22	Log Grate / Grille de Bûche		781-360A
23	Side Panel (Order as custom overlay, reference: 780-130)		N/A
24	Black Handles Assembly / L'Assemblée noire de Poignées		060-024A-BK
25	Louver / Louvre		781-144
26	Junction Box - IPI / Boîtier de raccordement - IPI		383-250A
	Lava Rock Bag / Le Sac de Rocher de lave		705-420
	Light Socket Assembly / L'Assemblée légère de Douille		700-108A
	Refractory Bracket / Crochet réfractaire		780-198
	51 inch Wire Harness / Harnais de fil		065-577A
	Wire Assembly / Module de fil		505-501A
	Ember Reflector / Réflecteur de braise		430-602
	Cord Assembly / Assemblée de corde		700-550A
	Mineral Wool / Laine minérale		050-721
	T-Handle / T-Poignée		567-313
ACCESSORIES / ACCESSOIRES			
	Remote Control Kit / Module de commande à distance		RC-SMART-HTL
	Remote Control Kit / Module de commande à distance		SMART-STAT-HTL
	Remote Control Kit / Module de commande à distance		RCT-MLT-HTL
	Wall Switch Kit / Interrupteur mural		WSK-MLT
	Wall Switch Kit, Off-white / Interrupteur mural, blanc crème		WSK-21
	Wall Switch Kit, White / Interrupteur mural, blanc		WSK-21-W
	Conversion Kit NG / Module de conversion GN		NGK-TITAN
	Conversion Kit LP / Module de conversion PL		LPK-TITAN
	Fan Kit* / Module de ventilateur*		GFK-160A

Also see following pages for additional valve assembly service part numbers.

NOTE: Replacement bulbs to be supplied by homeowner. Recommended replacements: Sylvania Mini Candelabra 75 watts. See Section 4: Maintaining and Servicing your Fireplace for instructions.

* In order to operate the fan kit, the fireplace must have either the WSK-MLT wall switch or RCT-MLT-HTL remote kit.

(NG, LP) Exploded Parts Diagram
(GN, PL) Vue éclatée des pièces

Beginning Manufacturing Date: 10/02
Ending Manufacturing Date: 2/1/04

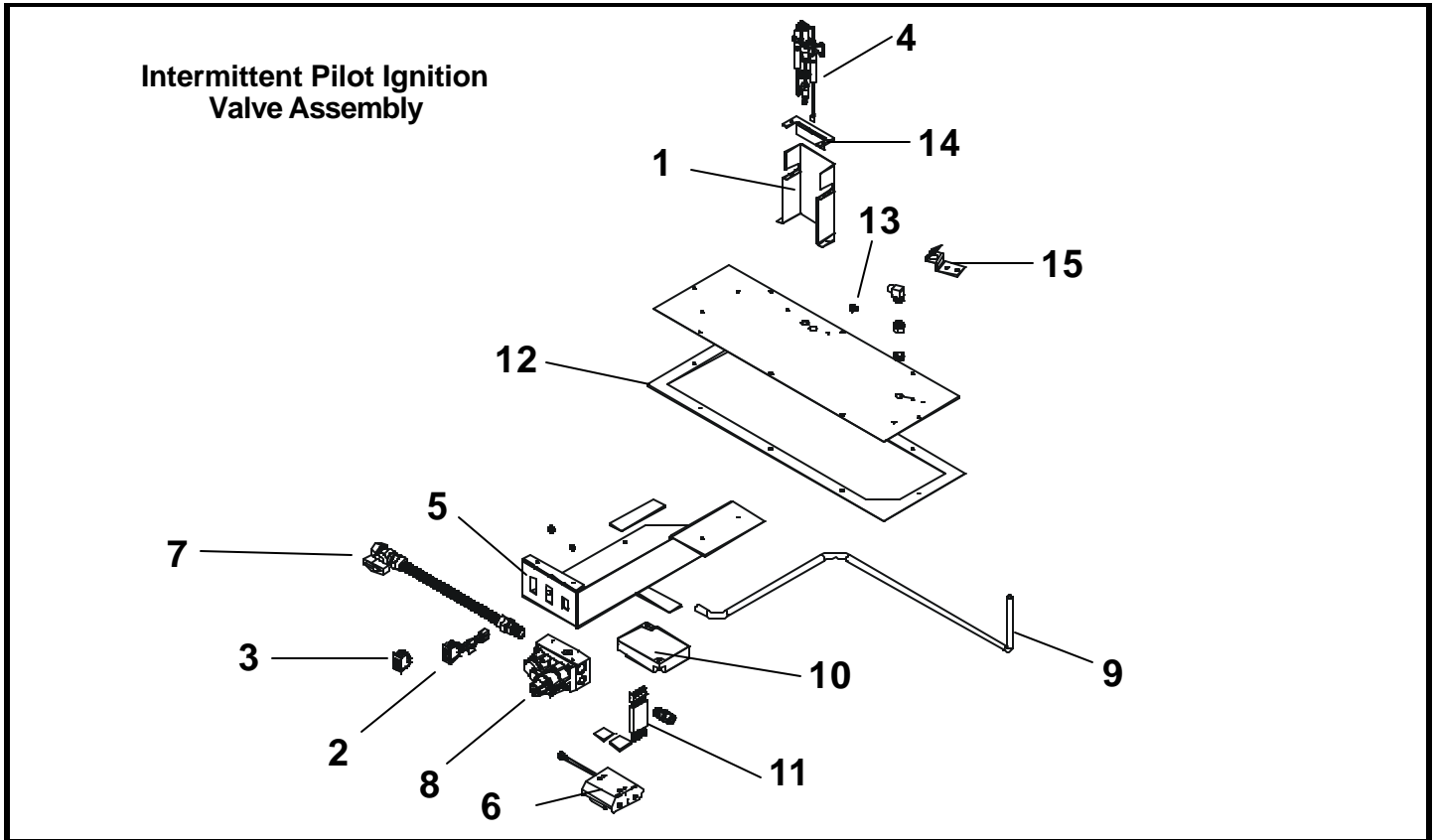

ITEM / PIÈCE	DESCRIPTION	SERIAL # / N° DE SÉRIE	PART NUMBER / N° DE PIÈCE
1	Pilot Bracket / Parenthèse Pilote		781-164
2	ON/OFF Rocker Switch / Interrupteur à bascule MARCHÉ/ARRÊT		060-521A
3	ON/OFF Rocker Switch / Interrupteur à bascule MARCHÉ/ARRÊT		060-511
4	Pilot Assembly NG / Module de veilleuse GN		385-510A
4	Pilot Assembly LP / Module de veilleuse PL		385-511A
5	Valve Bracket / Parenthèse de Valve		780-145
6	Battery Pack / Paquet de Batterie(Pile)		593-594A
7	Flex Ball Valve Assembly / Fléchir l'Assemblée de Soupape de Balle		302-320A
8	Valve NG / Valve GN		750-500
8	Valve LP / Valve PL		750-501
9	Flexible Gas Connector / Tuyau à gaz flexible		570-302A
10	Module / Module		593-592
11	Wire Assembly / Module de fil		593-590A
12	Valve Plate Gasket / Joint de Plat de Valve		780-431
13	Orifice Assembly NG (#26C) / Assemblée d'Orifice GN (#26C)		582-826
13	Orifice Assembly LP (#45C) / Assemblée d'Orifice PL (#45C)		582-845
14	Pilot Assembly Support / Appui d'Assemblée Pilote		397-121
15	Orifice Bracket / Parenthèse d'Orifice		781-165
	Ground Strap / Courroie de Raison(Terre)		385-512
	3 Volt Transformer / 3 Transformateur de Volt		593-593A

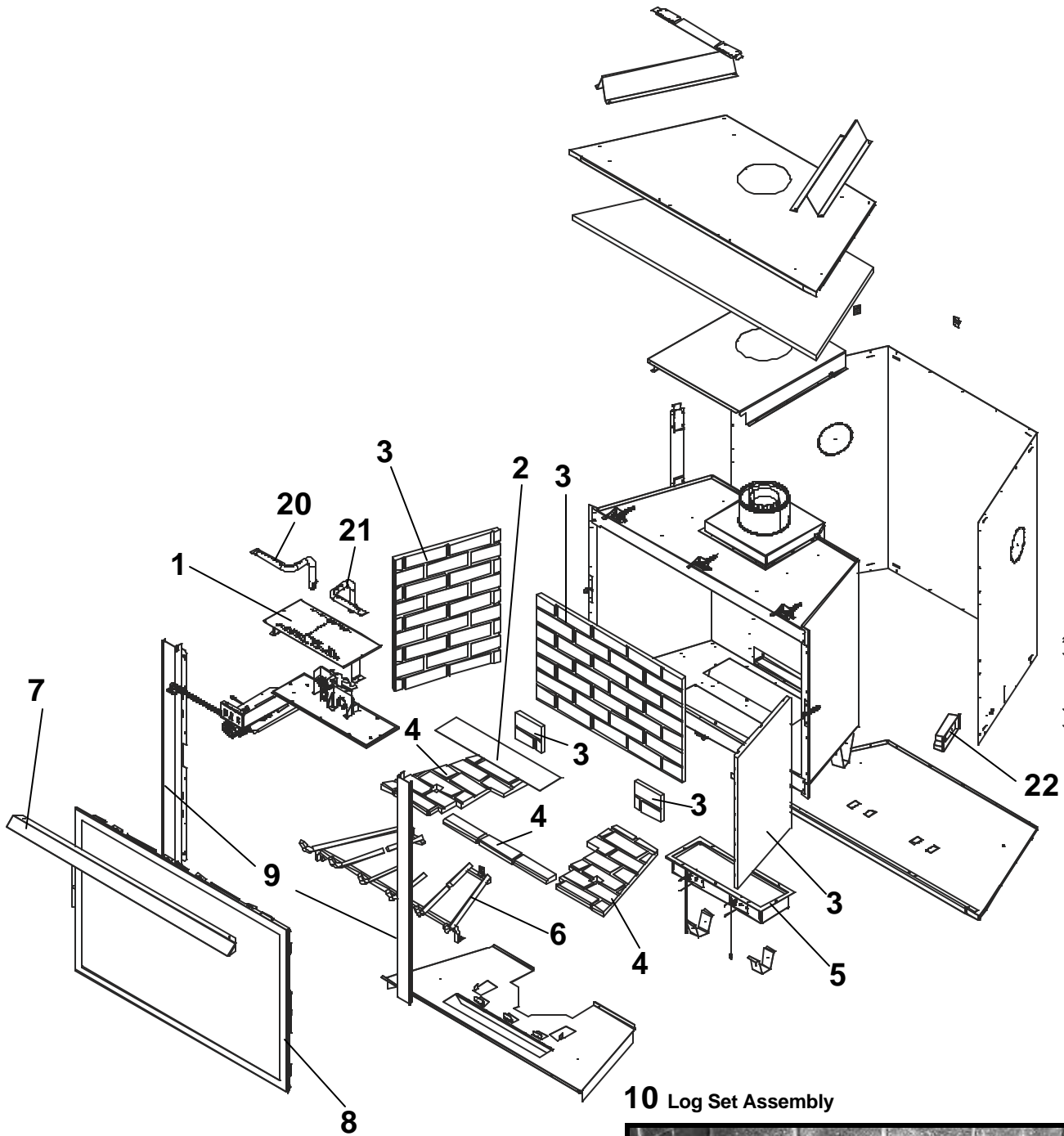

10 Log Set Assembly

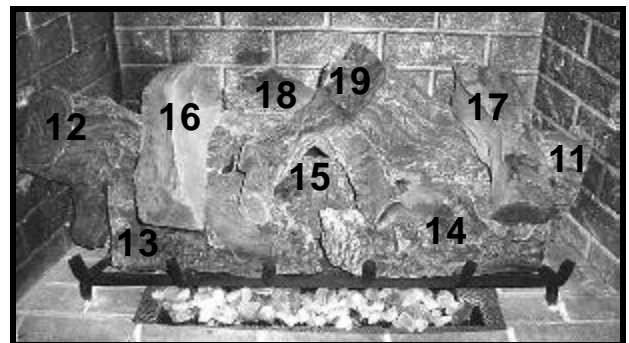

* Part number list on following page.
* La liste des numéros de pièce se trouve à la page suivante.

◆ (NG, LP) Service Parts List / (GN, PL) Liste des pièces de rechange

OLYMPUS

IMPORTANT: THIS IS DATED INFORMATION. The most current information is located on your dealers VIP site. When ordering, supply serial and model numbers to ensure correct service parts. / **IMPORTANT :** L'information fournie dans cette brochure n'est valide que pendant une courte période. Les sites VIP des distributeurs disposent des renseignements les plus récents. Lors d'une commande, veuillez fournir les numéros de série et de modèles pour un remplacement adéquat des pièces.

ITEM / PIÈCE	IPI IGNITION / ALLUMAGE IPI	SERIAL # / N° DE SÉRIE	PART NUMBER / N° DE PIÈCE
1	Burner LP / Brûleur PL		780-175A
1	Burner NG / Brûleur GN		780-176A
2	Ember Mesh Screen / Écran		780-382
3	Sides and Back Refractory / Réfractaire côté et arrière		SRV780-730A
4	Base Refractory Assembly / Model de réfractaire Base		SRV780-732A
5	Electric Ember Box / La Boîte Electrique de Braise		780-197A
6	Log Grate / Grille de Bûche		780-360A
7	Hood / Hotte		SRV570-143
8	Glass Door Assembly / Porte en verre		GLA-780
9	Side Panel (Order as custom overlay, reference: 780-130)		NA
10	Log Set Assembly / Jeu de Bûches		LOGS-OLY
11	Log 1 / Bûche 1		SRV780-701
12	Log 2 / Bûche 2		SRV780-702
13	Log 3 / Bûche 3		SRV780-703
14	Log 4 / Bûche 4		SRV780-704
15	Log 5 / Bûche 5		SRV780-705
16	Log 6 / Bûche 6		SRV780-706
17	Log 7 / Bûche 7		SRV780-707
18	Log 8 / Bûche 8		SRV780-708
19	Log 9 / Bûche 9		SRV780-709
20	Left NG Burner Tube / Tube de brûleur gauche GN		780-300A
20	Left LP Burner Tube / Tube de brûleur gauche PL		780-302A
21	Right NG Burner Tube / Tube de brûleur droite GN		780-301A
21	Right LP Burner Tube / Tube de brûleur droite PL		780-303A
22	Junction Box - IPI / Boîtier de raccordement - IPI		383-250A
	Lava Rock Bag / Le Sac de Rocher de lave		705-420
	Light Socket Assembly / L'Assemblée légère de Douille		700-108A
	Refractory Bracket / Crochet réfractaire		780-198
	51 inch Wire Harness / Harnais de fil		065-577A
	Wire Assembly / Module de fil		505-501A
	Ember Reflector / Réflecteur de braise		430-602
	Cord Assembly / Assemblée de corde		700-550A
	Mineral Wool / Laine minérale		050-721
	T-Handle / T-Poignée		567-313
	Golden Embers / Braises dorées		GE-93
ACCESSORIES / ACCESSOIRES			
	Remote Control Kit / Module de commande à distance		RC-SMART-HNG
	Remote Control Kit / Module de commande à distance		SMART-STAT-HNG
	Remote Control Kit / Module de commande à distance		RCT-MLT-HNG
	Wall Switch Kit / Interrupteur mural,		WSK-MLT
	Wall Switch Kit, Off-white / Interrupteur mural, blanc crème		WSK-21
	Wall Switch Kit, White / Interrupteur mural, blanc		WSK-21-W
	Conversion Kit NG / Module de conversion GN		NGK-OLY
	Conversion Kit LP / Module de conversion PL		LPK-OLY
	Fan Kit * / Module de ventilateur*		GFK-160A

Also see following pages for additional valve assembly service part numbers.

NOTE: Replacement bulbs to be supplied by homeowner. Recommended replacements: Sylvania Mini Candelabra 75 watts. See Section 4: Maintaining and Servicing your Fireplace for instructions.

* In order to operate the fan kit, the fireplace must have either the WSK-MLT wall switch or RCT-MLT-HNG remote kit.

(NG, LP) Exploded Parts Diagram
(GN, PL) Vue éclatée des pièces

Beginning Manufacturing Date: 10/02
Ending Manufacturing Date: _____

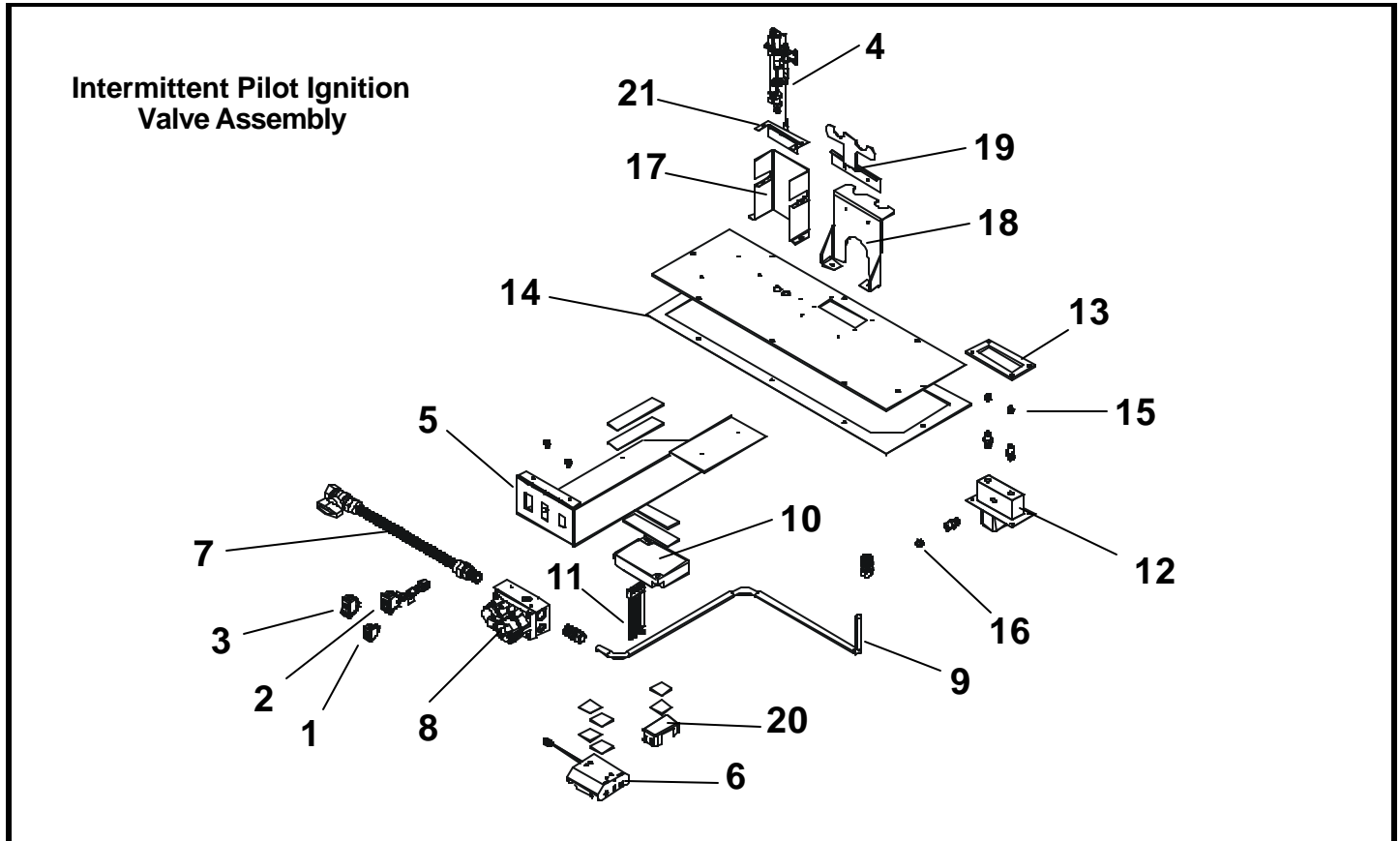

ITEM / PIÈCE	DESCRIPTION	SERIAL # / N° DE SÉRIE	PART NUMBER / N° DE PIÈCE
1	Switch Assembly, Solenoid / Changer l'Assemblée, le Solénoïde		386-520A
2	ON/OFF Rocker Switch / Interrupteur à bascule MARCHÉ/ARRÊT		060-521A
3	ON/OFF Rocker Switch / Interrupteur à bascule MARCHÉ/ARRÊT		060-511
4	Pilot Assembly NG / Module de veilleuse GN		385-510A
4	Pilot Assembly LP / Module de veilleuse PL		385-511A
5	Valve Bracket / Parenthèse de Valve		780-145
6	Battery Pack / Paquet de Batterie(Pile)		593-594A
7	Flex Ball Valve Assembly / Fléchir l'Assemblée de Soupape de Balle		302-320A
8	Valve NG / Valve GN		593-500
8	Valve LP / Valve PL		593-501
9	Flexible Gas Connector / Tuyau à gaz flexible		570-302A
10	Module / Module		593-592
11	Wire Assembly / Module de fil		593-590A
12	Manifold Assembly / L'Assemblée diverse		386-301A
13	Manifold Gasket / Joint Diversifié(Varié)		385-410
14	Valve Plate Gasket / Joint de Plat de Valve		780-431
15	Orifice Assembly NG (#46C) (Requires 2) / Assemblée d'Orifice GN (#46C)		582-846
15	Orifice Assembly LP (#62C) (Requires 2) / Assemblée d'Orifice PL (#62C)		582-862
16	Orifice Assembly NG (#35C) / Assemblée d'Orifice GN (#35C)		582-835
16	Orifice Assembly LP (#51C) / Assemblée d'Orifice PL (#51C)		582-851
17	Pilot Bracket / Parenthèse Pilote		780-164
18	Burner Tube Bracket / Le Crochet de Tube de brûleur		780-149
19	Burner Tube Bracket / Le Crochet de Tube de brûleur		780-147
20	9 Volt Battery Holder / 9 Porte-Pile de Volt		386-511
21	Pilot Assembly Support / Appui d'Assemblée Pilote		397-121
	3 Volt Transformer / 3 Transformateur de Volt		593-593A

1

Approvals and Codes

Appliance Certification

The Hearth & Home Technologies fireplace models discussed in this *Installers Guide* have been tested to certification standards and listed by the applicable laboratories.

Certification
MODELS: Olympus, Titan
LABORATORY: Underwriters Laboratories
TYPE: Vented Gas Fireplace Heater
STANDARD: ANSI Z21.88•CGA2.22•UL307B

Installation Codes

The fireplace installation must conform to local codes. Before installing the fireplace, consult the local building code agency to ensure that you are in compliance with all applicable codes, including permits and inspections.

In the absence of local codes, the fireplace installation must conform to the National Fuel Gas Code ANSI Z223.1 (in the United States) or the CAN/CGA-B149 Installation Codes (in Canada). The appliance must be electrically grounded in accordance with local codes or, in the absence of local codes with the National Electric Code ANSI/NFPA No. 70 (in the United States), or to the CSA C22.1 Canadian Electric Code (in Canada).

These models may be installed in a bedroom or bed-sitting room in the U.S.A. and Canada.

High Altitude Installations

U.L. Listed gas appliances are tested and approved without requiring changes for elevations from 0 to 2,000 feet in the U. S. A. and in Canada.

When installing this appliance at an elevation above 2,000 feet, it may be necessary to decrease the input rating by changing the existing burner orifice to a smaller size. Input rate should be reduced by 4% for each 1000 feet above a 2000 foot elevation in the U.S.A. or 10% for elevations between 2000 and 4500 feet in Canada. If the heating value of the gas has been reduced, these rules do not apply. To identify the proper orifice size, check with the local gas utility.

If installing this appliance at an elevation above 4,500 feet (in Canada), check with local authorities.

2

Getting Started

Introducing the Hearth & Home Technologies Gas Fireplaces

Hearth & Home Technologies direct vent gas fireplaces are designed to operate with all combustion air siphoned from outside of the building and all exhaust gases expelled to the outside.

The information contained in this *Installers Guide*, unless noted otherwise, applies to all models and gas control systems. Gas fireplace diagrams, including the dimensions, are shown in this section.

Pre-install Preparation

This gas fireplace and its components are tested and safe when installed in accordance with this *Installers Guide*. Report to your dealer any parts damaged in shipment, particularly the condition of the glass. **Do not install any unit with damaged, incomplete, or substitute parts.**

The vent system components are shipped in separate packages. The gas logs are packaged separately and must be field installed.

Read all of the instructions before starting the installation. Follow these instructions carefully during the installation to ensure maximum safety and benefit. Failure to follow these instructions will void the owner's warranty and may present a fire hazard.

The Hearth & Home Technologies Warranty will be voided by, and Hearth & Home Technologies disclaims any responsibility for, the following actions:

- Installation of any damaged fireplace or vent system component.
- Modification of the fireplace or direct vent system.
- Installation other than as instructed by Hearth & Home Technologies.
- Improper positioning of the gas logs or the glass door.
- Installation and/or use of any component part not manufactured and approved by Hearth & Home Technologies, notwithstanding any independent testing laboratory or other party approval of such component part or accessory.

ANY SUCH ACTION MAY POSSIBLY CAUSE A FIRE HAZARD.

When planning a fireplace installation, it's necessary to determine:

- Where the unit is to be installed.
- The vent system configuration to be used.
- Gas supply piping.
- Electrical wiring.
- Framing and finishing details.
- Whether optional accessories—devices such as a fan, wall switch or remote control—are desired.

If the fireplace is to be installed on carpeting or tile, or on any combustible material other than wood flooring, the fireplace should be installed on a metal or wood panel that extends the full width and depth of the fireplace.

Dimensions in inches.
 Dimensions in brackets are millimeters.

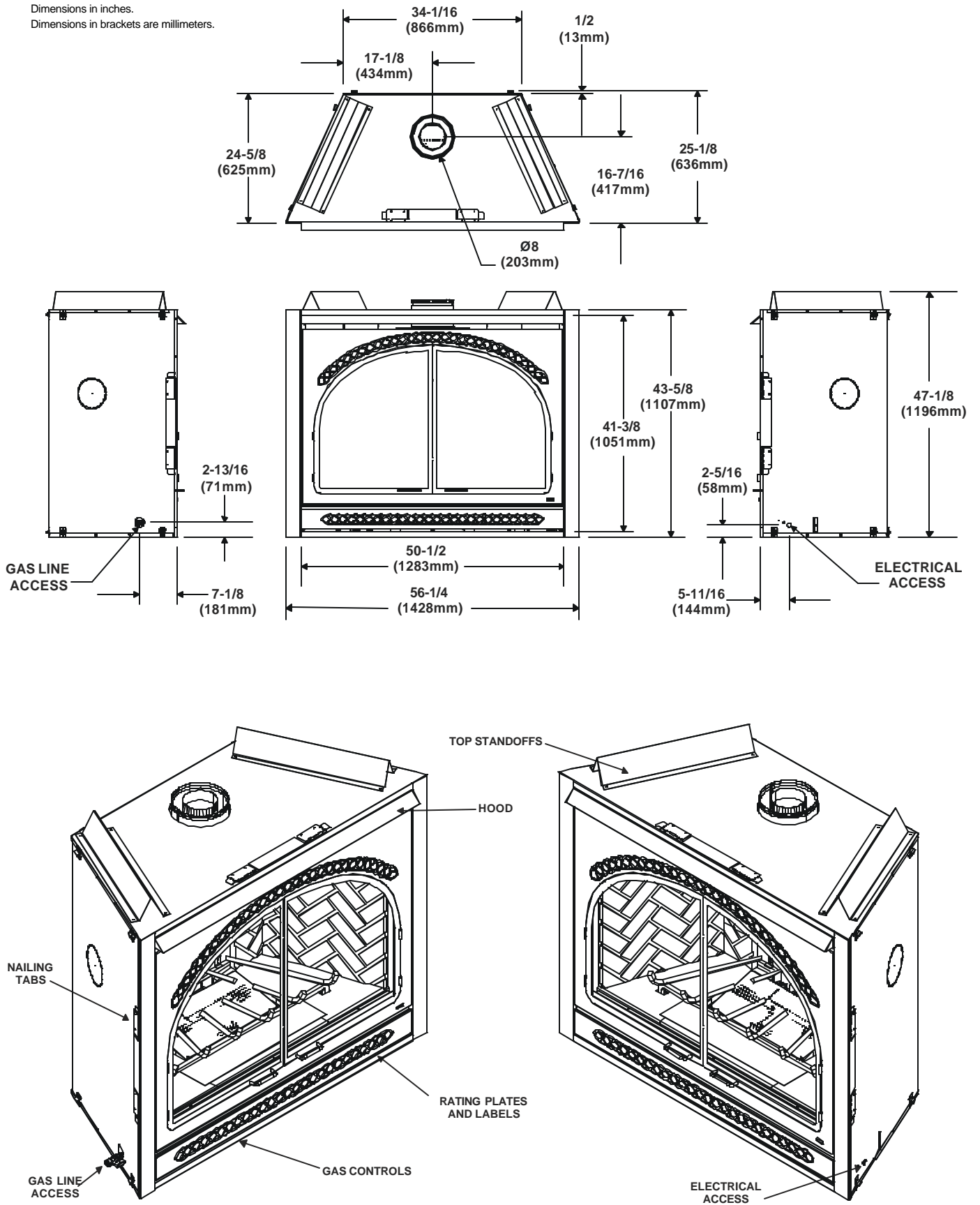

Figure 1. Diagram of Titan

Dimensions in inches.

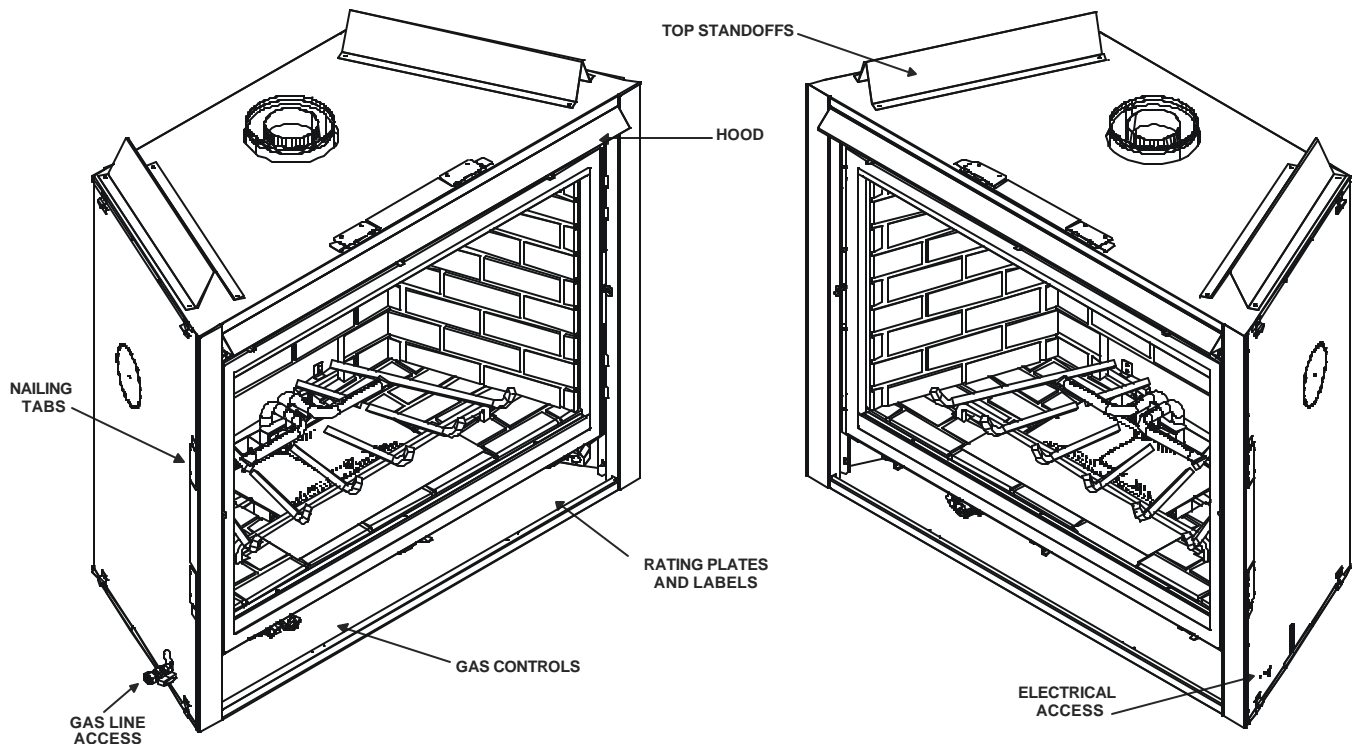
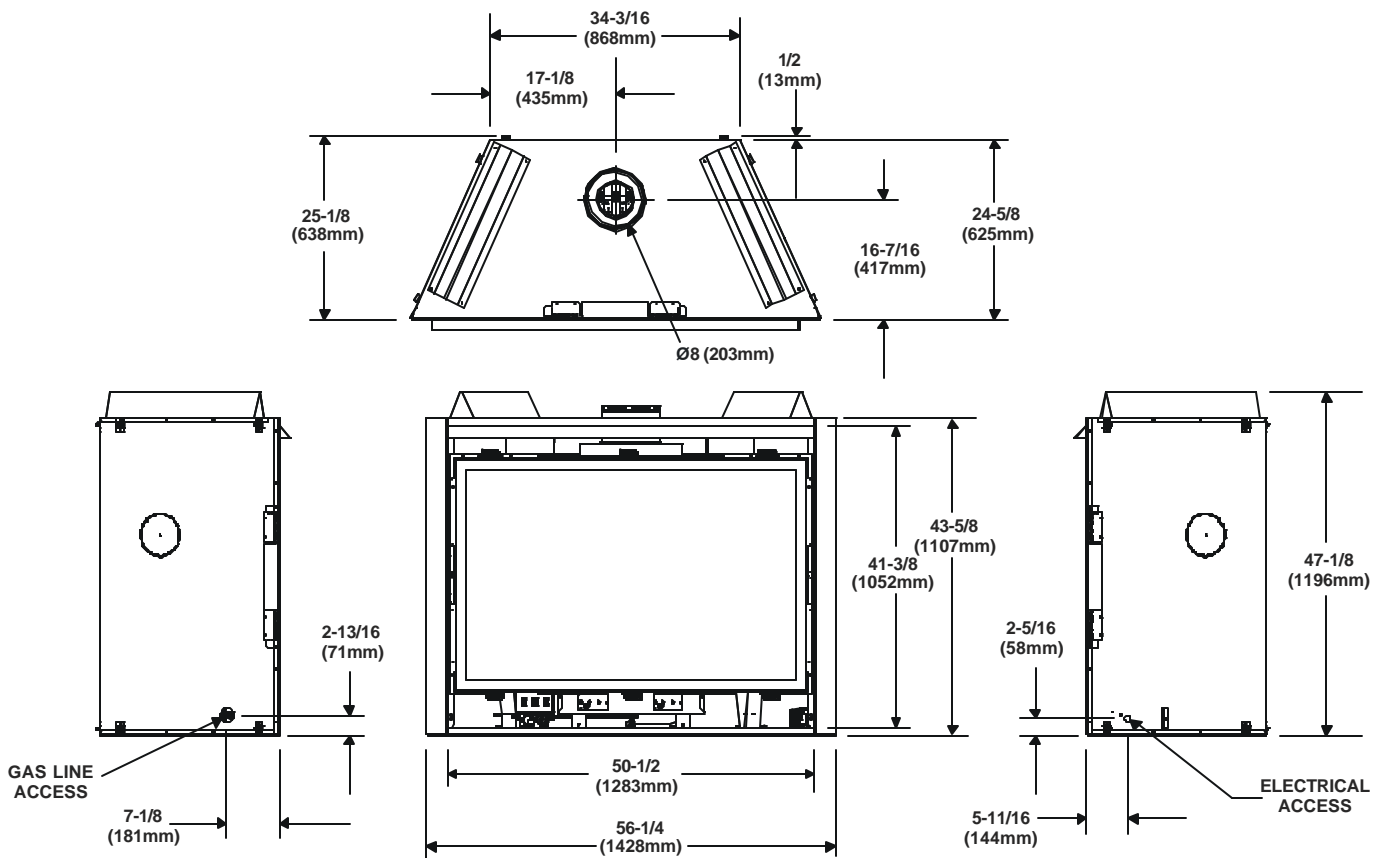

Figure 2. Diagram of Olympus

3

Installing the Fireplace

Step 1. Locating the Fireplace

The diagram below shows space and clearance requirements for locating a fireplace within a room.

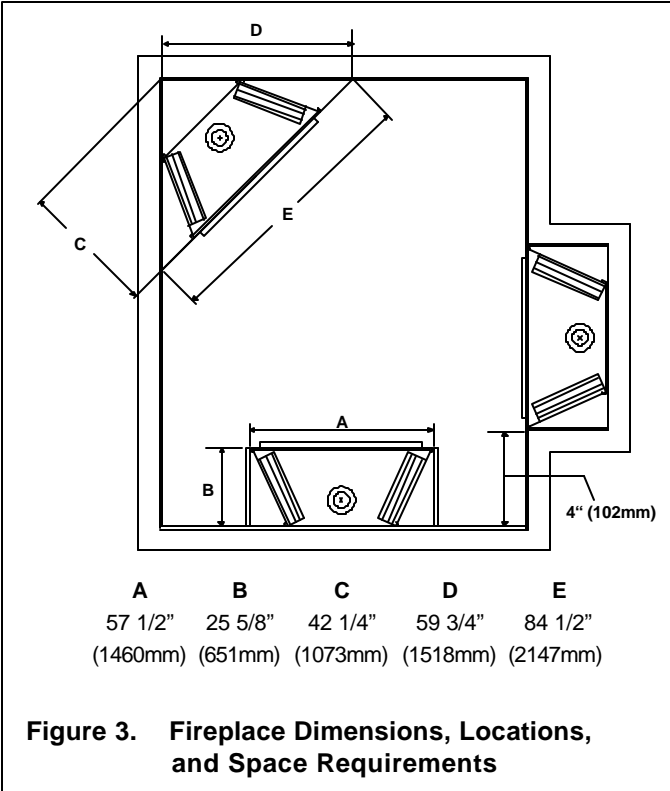

Clearance Requirements

The top, back, and sides of the fireplace are defined by stand-offs. The minimum clearance to a perpendicular wall extending past the face of the fireplace is 4 inches (102 mm). The back of the fireplace may be recessed 25 1/8 inches (638mm) into combustible construction.

Minimum Clearances from the Fireplace to Combustible Materials		
	<u>Inches</u>	<u>mm</u>
Glass Front	36	914
Floor	0	0
Rear	1/2	13
Sides	1/2	13
Top	3 1/2	89
Ceiling*	31	787

* The clearance to the ceiling is measured from the top of the unit, excluding the standoffs (see Figure 26).

The distance from the unit to combustible construction is to be measured from the unit outer wrap surface to the combustible construction, **NOT** from the screw heads that secure the unit together.

Minimum Clearances from the Vent Pipe to Combustible Materials		
	<u>Inches</u>	<u>mm</u>
Vertical Sections	1	25
Horizontal Sections		
Top	3*	75
Bottom	1	25
Sides	1	25
At Wall Firestops		
Top	3	75
Bottom	1	25
Sides	1	25

* When using DVP-Series pipe additional clearance and/or installation of a heat shield is required above the first 90° elbow (see Figure 4).

For minimum clearances of direct vent termination see Figures 21 and 22.

NOTE: When venting with a 3 foot vertical and 90° elbow as the first two vent components, the non-combustible zone is the entire width and depth of the firebox from the top of the fireplace to 3" above the horizontal vent. This area must remain free of combustibles (see Figure 4).

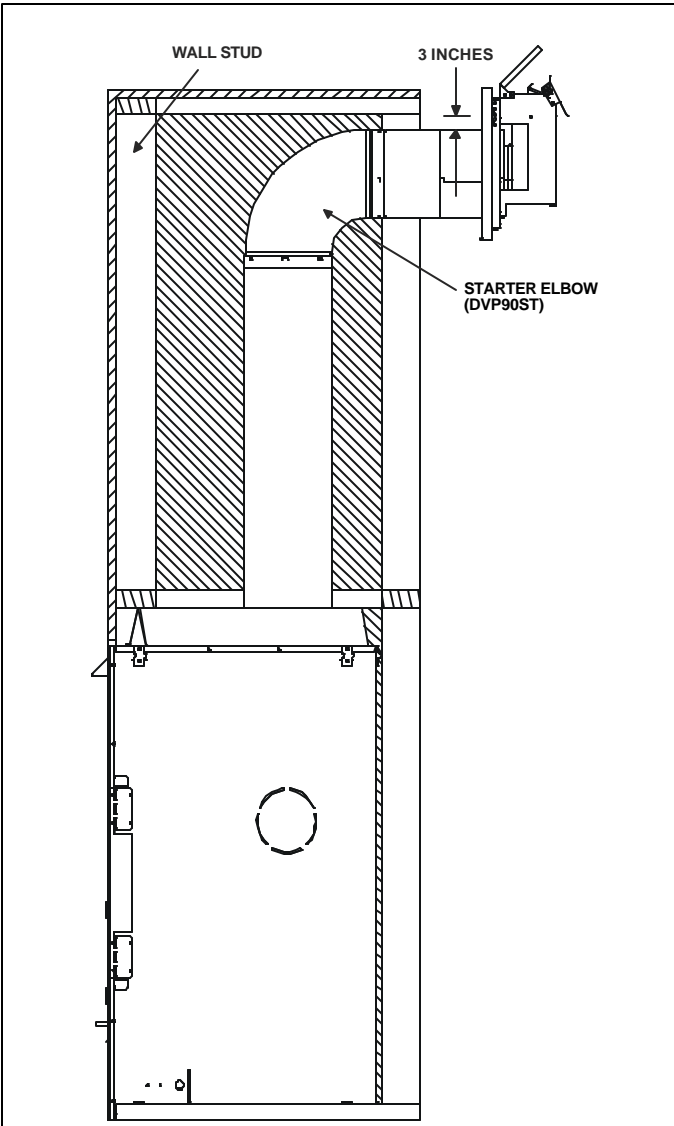

Figure 4. Non-combustible zone

Step 2. Framing the Fireplace

Fireplace framing can be built before or after the fireplace is set in place. Framing should be positioned to accommodate wall coverings and fireplace facing material. The diagram below shows framing reference dimensions.

CAUTION: MEASURE FIREPLACE DIMENSIONS AND VERIFY FRAMING METHODS AND WALL COVERING DETAILS BEFORE FRAMING.

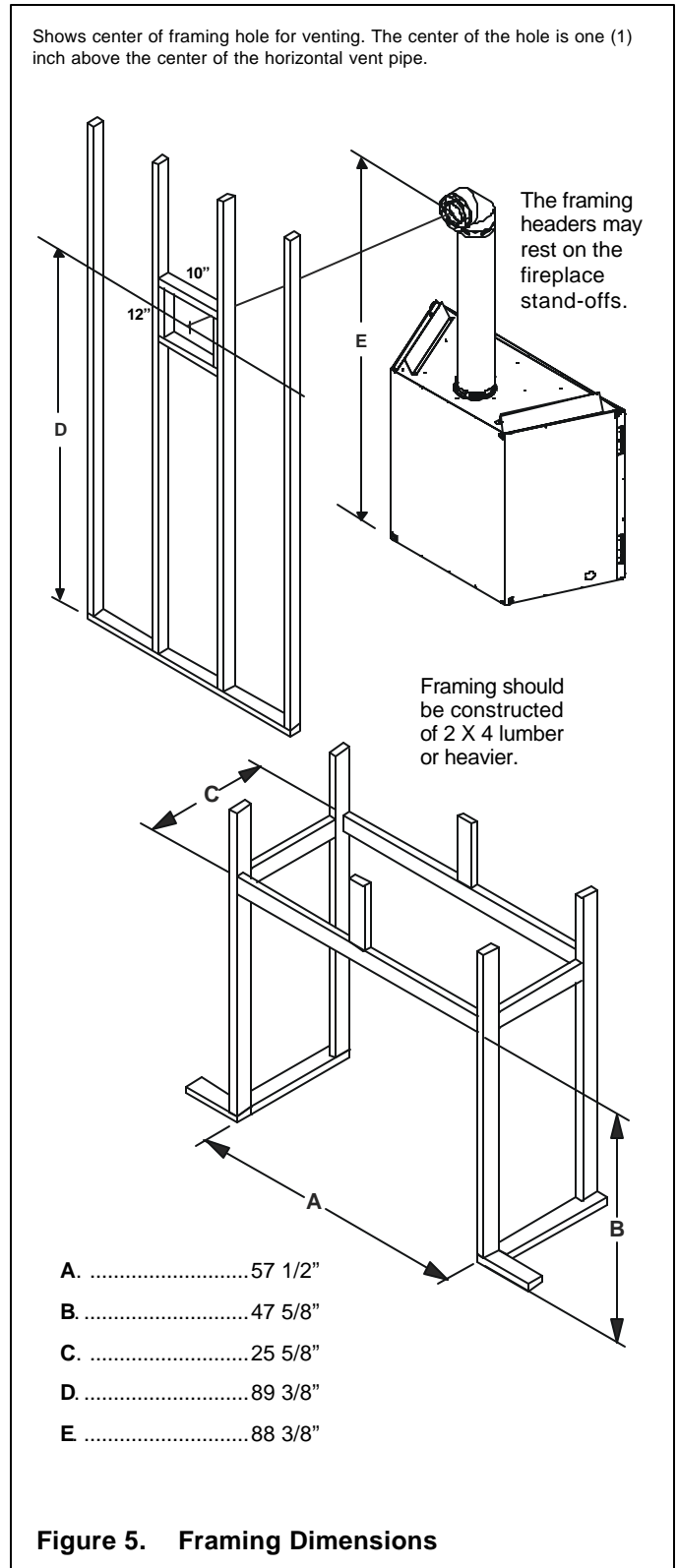

Figure 5. Framing Dimensions

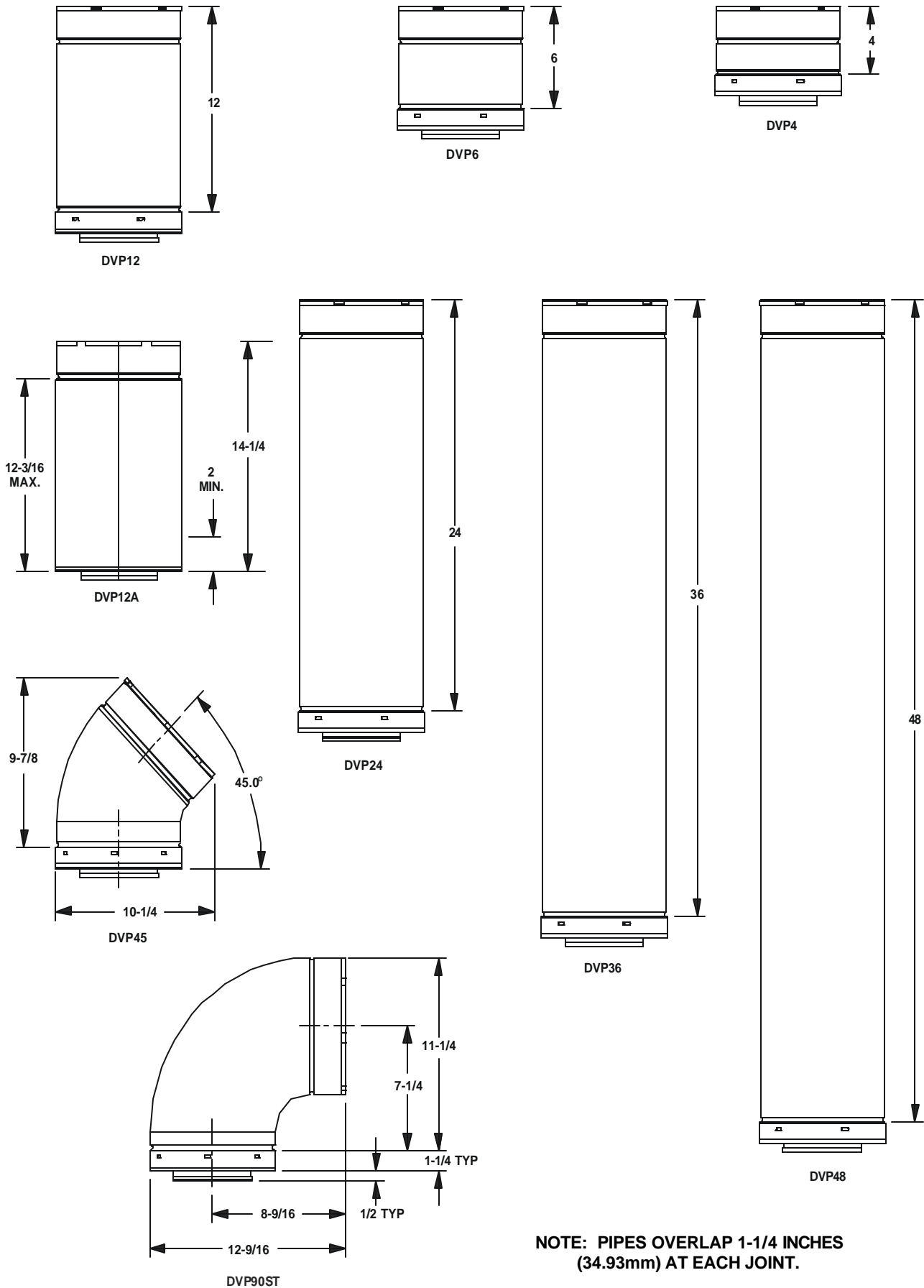

Figure 6. DVP-Series Direct Vent Component Specifications (5-inch inner pipe / 8-inch outer pipe)

Step 3. Installing the Vent System

A. Vent System Approvals

The Titan and Olympus models are approved to use DVP-series vent pipe components (Figures 6 and 7) and terminations. Approved vent system components are labeled for identification. This pipe is tested and listed as an approved component of the fireplace. The pipe is tested to be run inside an enclosed wall. There is no requirement for inspection openings at each joint within the wall. There is no required pitch for horizontal vent runs. **NO OTHER VENTING SYSTEMS OR COMPONENTS MAY BE USED.**

Detailed installation instructions are included with each vent termination kit and should be used in conjunction with this *Installers Guide*.

The flame and ember appearance may vary based on the type of fuel burned and the venting configuration used.

Identifying Vent Components

The vent systems installed on this gas fireplace may include one, two or three 90° elbow assemblies. The relationships of vertical rise to horizontal run in vent configurations using 90° elbows **MUST BE** strictly adhered to. The rise to run relationships are shown in the venting drawings and tables. Refer to the diagrams on the next several pages.

NOTE: Two 45° elbows may be used in place of one 90° elbow. Rise to run ratios in the vent system must be followed if 45° elbows are used.

WARNING: A 3-FOOT LENGTH OF STRAIGHT PIPE (MINIMUM) MUST BE THE FIRST VENT COMPONENT ATTACHED TO THE UNIT.

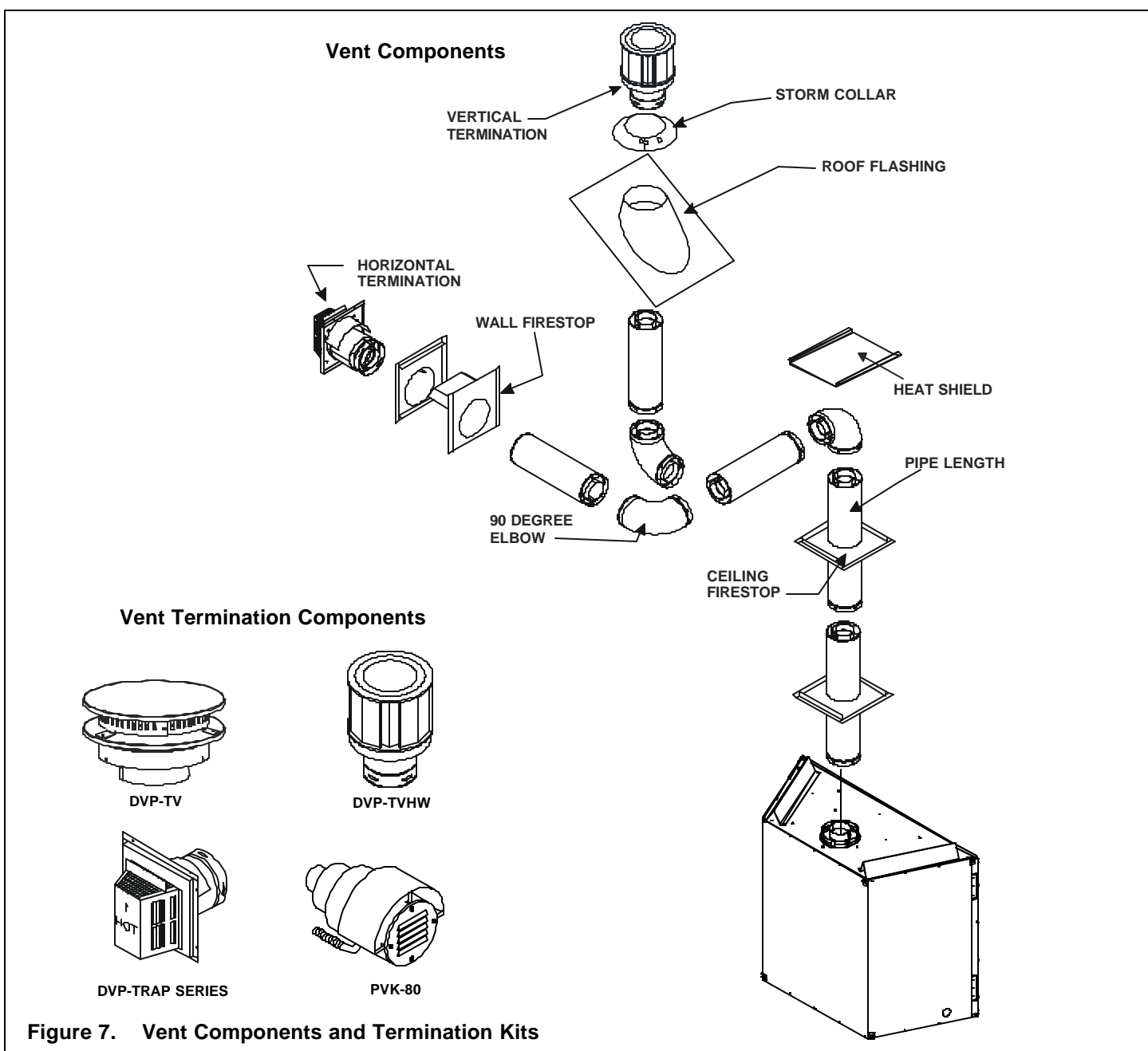

Figure 7. Vent Components and Termination Kits

**STRAIGHT UP
VERTICAL VENTING**

V (FT.)

40' MAX. (12.2 M)

3' MIN. (0.9 M)

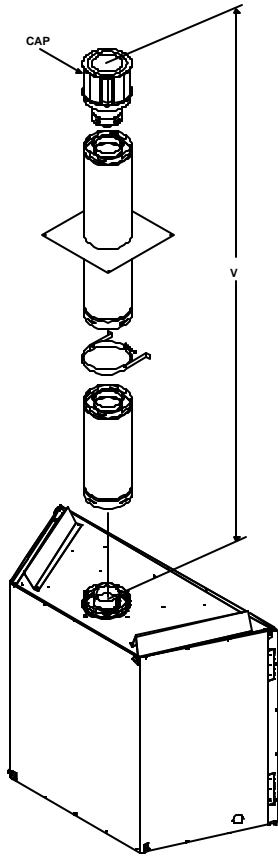

Figure 8. Straight Up Vertical Venting

VENTING WITH ONE (1) 90° ELBOW NG

V (FT.)	H (FT.)
3' MIN. (914 mm)	6' MAX. (1.9m)
4' MIN. (1.2m)	8' MAX. (2.4m)
5' MIN. (1.6m)	10' MAX. (3.1m)
6' MIN. (1.9m)	12' MAX. (3.6m)
V + H = 30' MAX. (9.3 m)	H = 20' MAX. (6.2m)
Ratio V to H = 1:2	

Note: When venting with LP on Olympus the V to H ratio is 1:1, and H = 15' MAX.

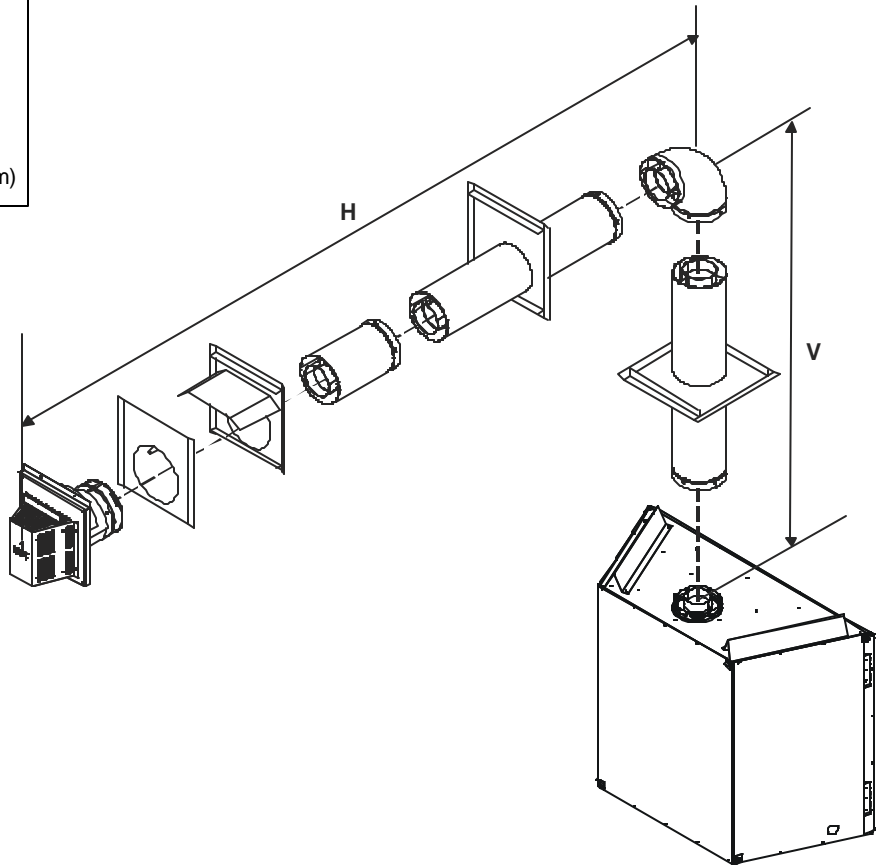
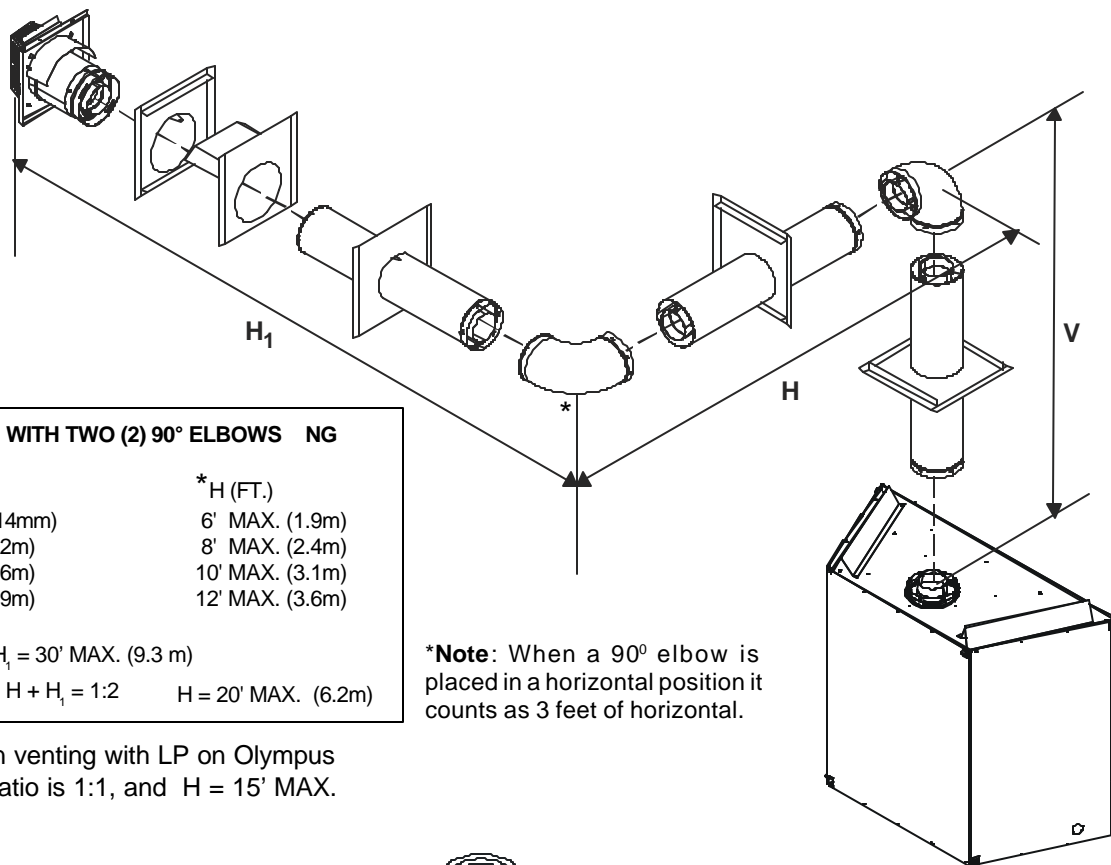

Figure 9. Venting with One 90° Elbow



VENTING WITH TWO (2) 90° ELBOWS NG

V (FT.)	* H (FT.)
3' MIN. (914mm)	6' MAX. (1.9m)
4' MIN. (1.2m)	8' MAX. (2.4m)
5' MIN. (1.6m)	10' MAX. (3.1m)
6' MIN. (1.9m)	12' MAX. (3.6m)

$V + H + H_1 = 30'$ MAX. (9.3 m)

Ratio V to $H + H_1 = 1:2$ $H = 20'$ MAX. (6.2m)

*Note: When a 90° elbow is placed in a horizontal position it counts as 3 feet of horizontal.

Note: When venting with LP on Olympus the V to H ratio is 1:1, and H = 15' MAX.

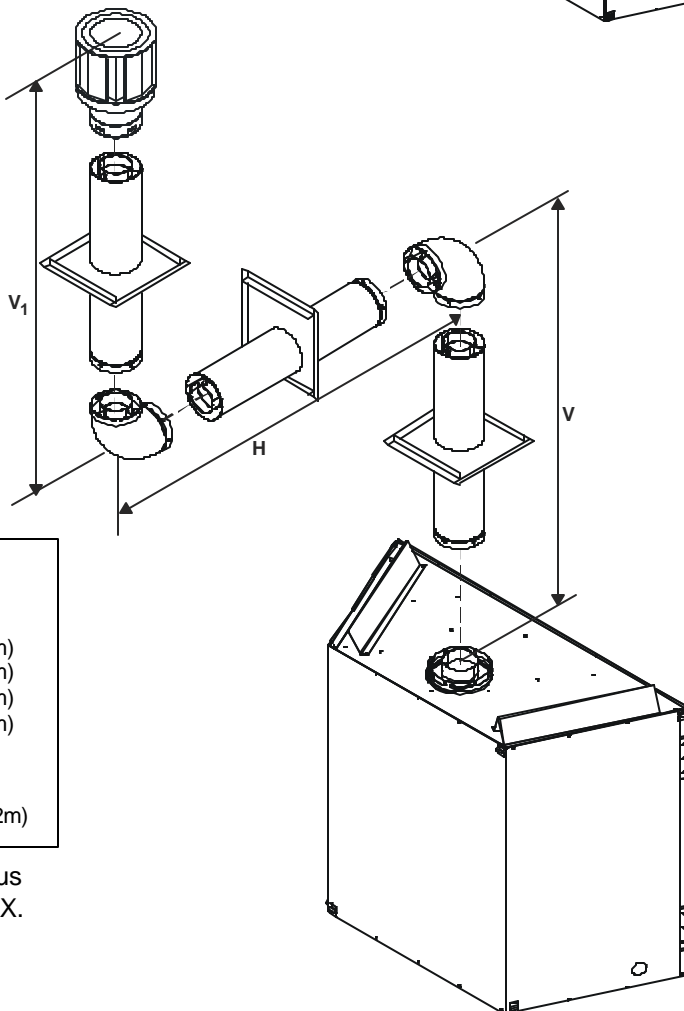

VENTING WITH TWO (2) 90° ELBOWS NG

V (FT.)	H (FT.)
3' MIN. (914 mm)	6' MAX. (1.9m)
4' MIN. (1.2m)	8' MAX. (2.4m)
5' MIN. (1.6m)	10' MAX. (3.1m)
6' MIN. (1.9m)	12' MAX. (3.6m)

$V + V_1 + H_1 = 30'$ MAX. (9.3 m)

Ratio V to H = 1:2 $H = 20'$ MAX. (6.2m)

Note: When venting with LP on Olympus the V to H ratio is 1:1, and H = 15' MAX.

◆ **Figure 10. Venting with two 90° elbows**

VENTING WITH THREE (3) 90° ELBOWS NG

V (FT.)	H (FT.)
3' MINIMUM (914 mm)	6' MAXIMUM (1.9 m)
4' MINIMUM (1.2 m)	8' MAXIMUM (2.4 m)
5' MINIMUM (1.6 m)	10' MAXIMUM (3.1 m)

RATIO V TO H = 1:2
 $V + V_1 + H + H_1 = 30'$ MAXIMUM (9.3m)
 $H + H_1 = 20'$ MAXIMUM (6.2m)
 $H = 10'$ MAXIMUM (3.1m)

Note: When venting with LP on Olympus the V to H ratio is 1:1, and H = 15' MAX.

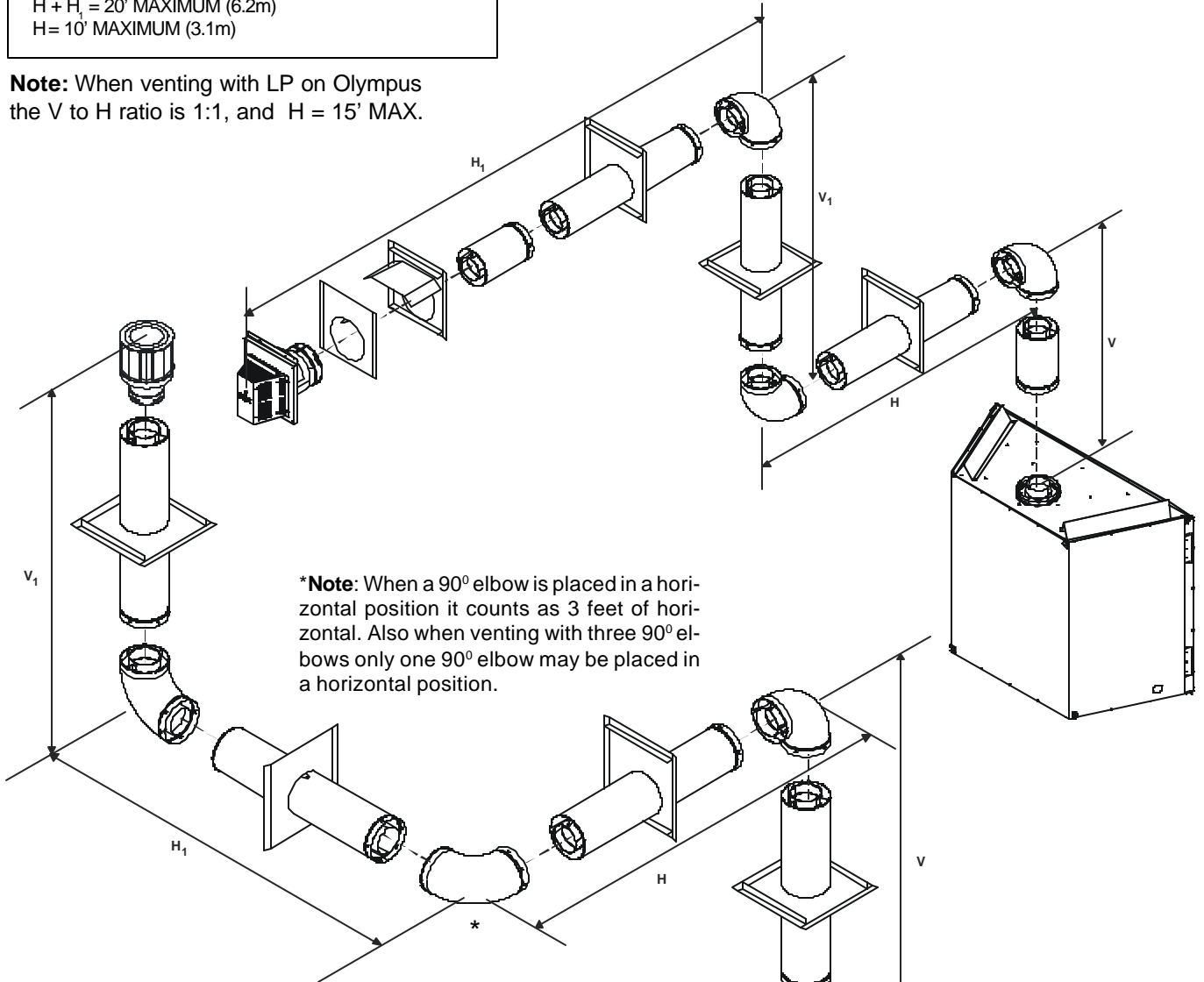

***Note:** When a 90° elbow is placed in a horizontal position it counts as 3 feet of horizontal. Also when venting with three 90° elbows only one 90° elbow may be placed in a horizontal position.

VENTING WITH THREE (3) 90° ELBOWS NG

V (FT.)	*H + H ₁ (FT.)
3' MINIMUM (914 mm)	6' MAXIMUM (1.9 m)
4' MINIMUM (1.2 m)	8' MAXIMUM (2.4 m)
5' MINIMUM (1.6 m)	10' MAXIMUM (3.1 m)
6' MINIMUM (1.9 m)	12' MAXIMUM (3.6 m)

$V + V_1 + H + H_1 = 30'$ MAXIMUM (9.3 m)
 $H + H_1 = 20'$ MAXIMUM (6.2 m)
 RATIO V TO $H + H_1 = 1:2$

Note: When venting with LP on Olympus the V to H ratio is 1:1, and H = 15' MAX.

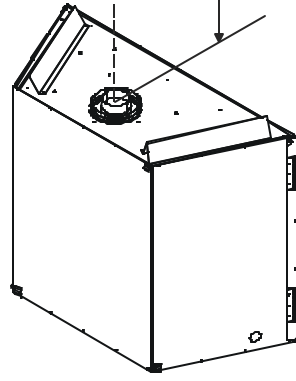

◆ **Figure 11. Venting with three 90° elbows**

B. Installing Vent Components

1. Attaching the Venting to the Fireplace

Refer to Cinch Pipe and Termination Cap installation instructions.

2. Assembling Vent Sections

Refer to Cinch Pipe and Termination Cap installation instructions.

If the installation is for a termination cap attached directly to the fireplace, skip to the sections, **Install Firestops** and **Vent Termination**.

- Continue adding vent components, locking each succeeding component into place.
- Ensure that each succeeding vent component is securely fitted and locked into the preceding component in the vent system.
- 90° elbows may be installed and rotated to any point around the preceding component's vertical axis. If an elbow does not end up in a locked position with the preceding component, attach with a minimum of two (2) sheet metal screws.

3. Install Support Brackets

Refer to Cinch Pipe and Termination Cap installation instructions.

4. Install Firestops

For Horizontal Runs - Firestops are **REQUIRED** on both sides of a combustible wall through which the vent passes.

NOTE: Model DVP-TRAP does not need an exterior firestop on an exterior combustible wall.

To install firestops for horizontal runs that pass through either interior or exterior walls:

- Cut a 10-inch by 12-inch (245mm x 305mm) hole through the wall.

NOTE: The center of the hole is one (1) inch (25.4mm) above the center of the horizontal vent pipe.

- Position the firestops on both sides of the hole previously cut and secure the firestops with nails or screws.
- The heat shields of the firestops **MUST BE** placed towards the top of the hole.
- Continue the vent run through the firestops.

NOTE: There must be NO INSULATION or other combustibles inside the framed firestop opening.

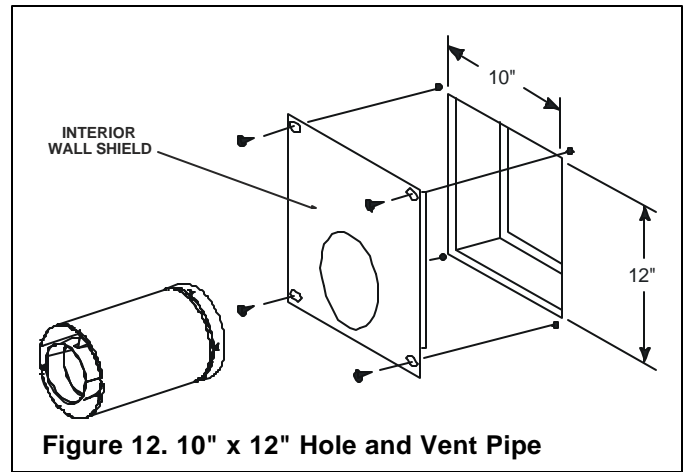

Figure 12. 10" x 12" Hole and Vent Pipe

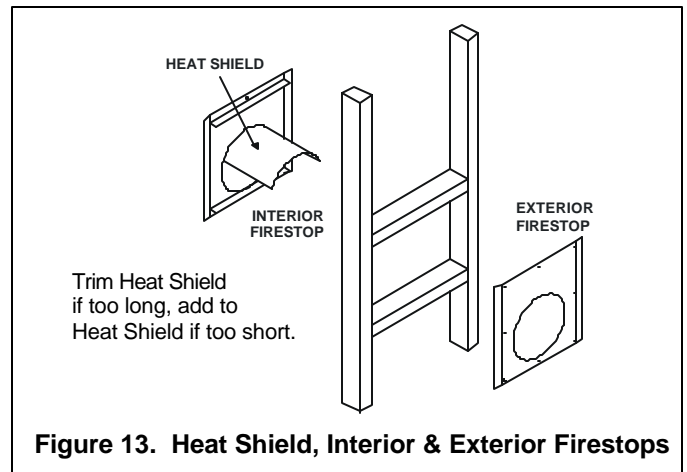

Figure 13. Heat Shield, Interior & Exterior Firestops

For Vertical Runs - One ceiling firestop is **REQUIRED** at the hole in each ceiling through which the vent passes.

To install firestops for vertical runs that pass through ceilings:

- Position a plumb bob directly over the center of the vertical vent component.
- Mark the ceiling to establish the centerpoint of the vent.
- Drill a hole or drive a nail through this centerpoint.
- Check the floor above for any obstructions, such as wiring or plumbing runs.
- Reposition the fireplace and vent system, if necessary, to accommodate the ceiling joists and/or obstructions.
- Cut a 10-inch x 10-inch (254mm x 254mm) hole through the ceiling, using the centerpoint previously marked.
- Frame the hole with framing lumber the same size as the ceiling joists.

NOTE: There must be NO INSULATION or other combustibles inside the framed firestop opening.

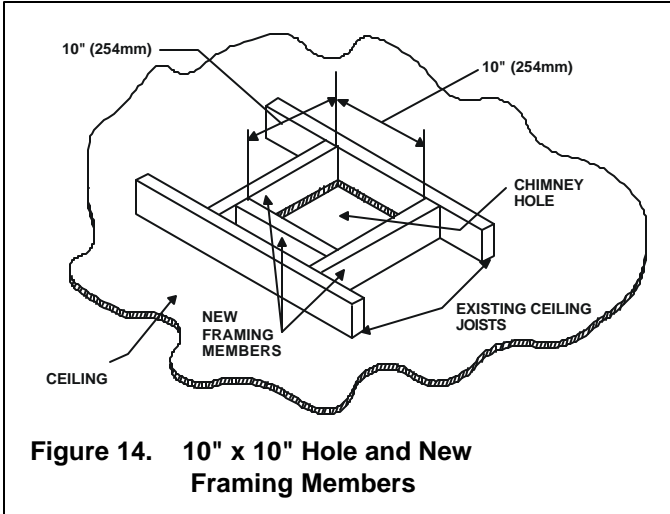

Figure 14. 10" x 10" Hole and New Framing Members

If the area above the ceiling is **NOT** an attic, position and secure the ceiling firestop on the ceiling side of the previously cut and framed hole.

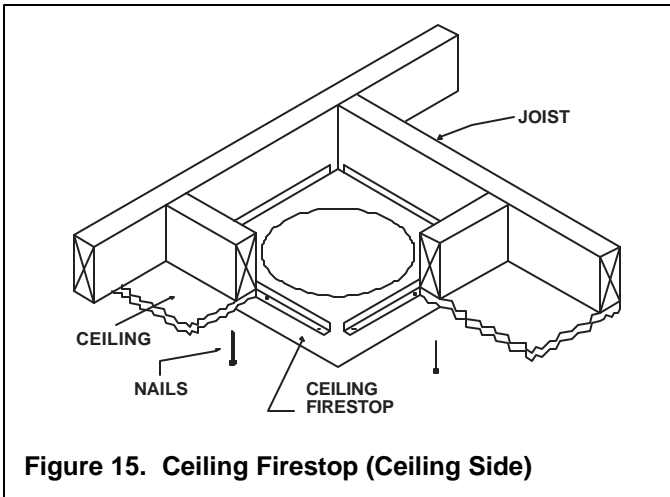

Figure 15. Ceiling Firestop (Ceiling Side)

If the area above the ceiling **IS** an attic, position and secure the firestop on top of the previously framed hole.

NOTE: Keep insulation away from the vent pipe at least 1 inch (25mm).

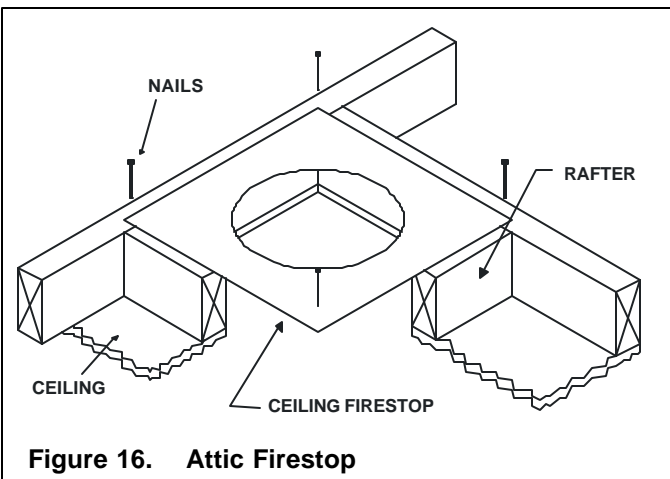

Figure 16. Attic Firestop

C. Vent Termination

Refer to Cinch Pipe and Termination Cap installation instructions.



WARNING: THE TERMINATION CAP MUST BE POSITIONED SO THAT THE ARROW IS POINTING UP.



WARNING: VENTING TERMINALS SHALL NOT BE RECESSED INTO A WALL OR SIDING. VENT TERMINATION CLEARANCES MUST BE FOLLOWED TO AVOID FIRE DANGER. SEE VENT TERMINATION MINIMUM CLEARANCES DIAGRAM ON FOLLOWING PAGE.

Horizontal terminations require insulation (included with the fireplace) to be placed directly above the heatshield on DVP-TR termination kit. Failure to correctly install this insulation could possibly result in a fire hazard.

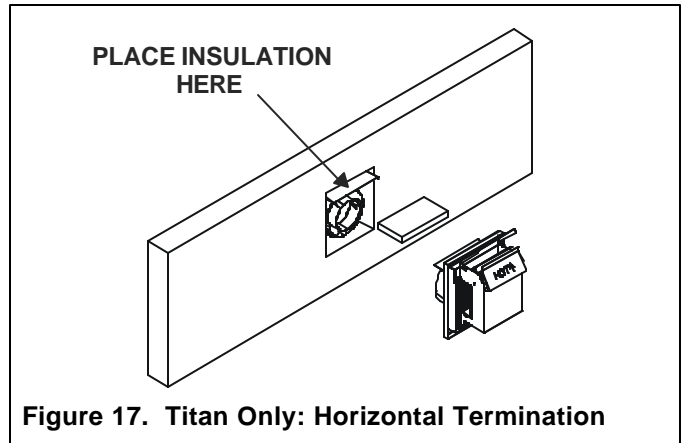

Figure 17. Titan Only: Horizontal Termination

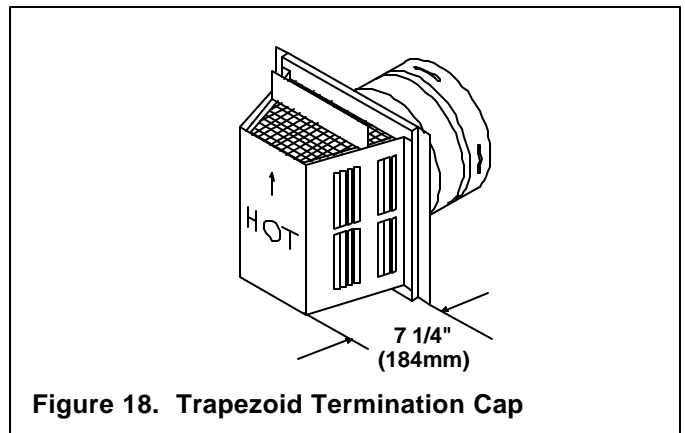
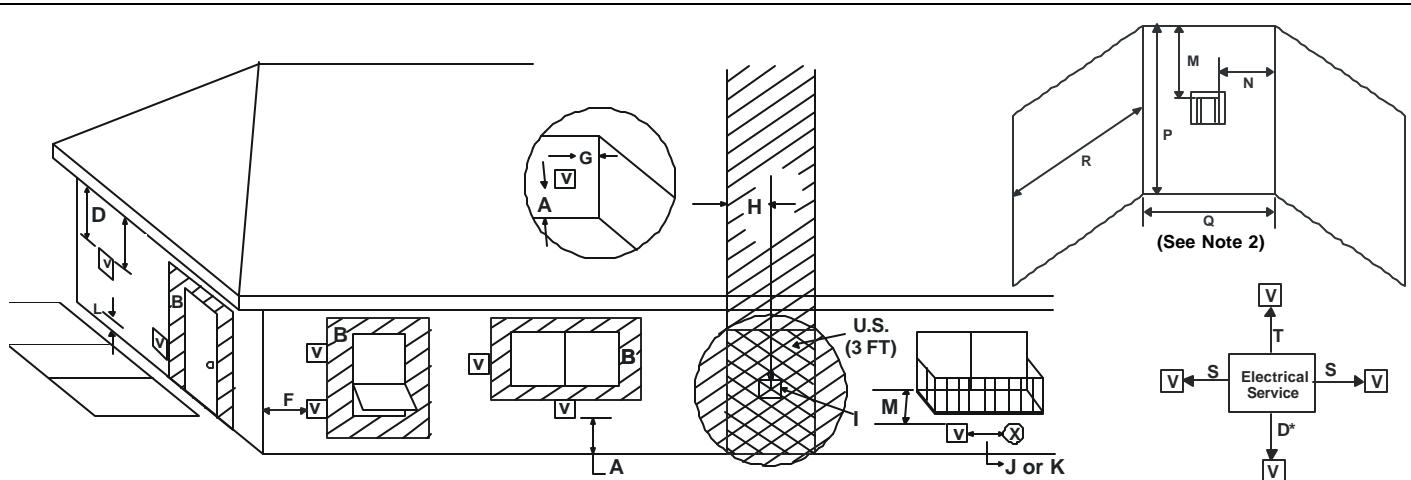

Figure 18. Trapezoid Termination Cap



V = VENT TERMINAL **X** = AIR SUPPLY INLET **[Hatched]** = AREA WHERE TERMINAL IS NOT PERMITTED

- A = 12" clearances above grade, veranda, porch, deck or balcony
(See Note 1)
- B = 12" clearances to window or door that may be opened, or to permanently closed window.
- D* = 36" vertical clearance to unventilated soffit or to ventilated soffit located above the terminal
*60" for vinyl clad soffits and below electrical service
- F = 9" clearance to outside corner
- G = 6" clearance to inside corner
- H = 3 ft. (Canada) not to be installed above a gas meter/regulator assembly within 3 feet (90cm) horizontally from the center-line of the regulator
- I = 3 ft. (U.S.A.)
6 ft. (Canada) clearance to gas service regulator vent outlet
- J = 9" (U.S.A.)
12" (Canada) clearance to non-mechanical air supply inlet to building or the combustion air inlet to any other appliance

- K = 3 ft. (U.S.A.)
6 ft. (Canada) clearance to a mechanical air supply inlet
- L** = 7 ft. clearance above paved sidewalk or a paved driveway located on **public** property
(See Note 1)
- M*** = 36" clearance under veranda, porch, deck, balcony or overhang
60" vinyl
- N = 6" non-vinyl sidewalls
12" vinyl sidewalls
- P = 8 ft.

	Q_{MIN}	R_{MAX}
1 cap	3 feet	$2 \times Q_{ACTUAL}$
2 caps	6 feet	$1 \times Q_{ACTUAL}$
3 caps	9 feet	$2/3 \times Q_{ACTUAL}$
4 caps	12 feet	$1/2 \times Q_{ACTUAL}$
$Q_{MIN} = \# \text{ termination caps} \times 3$ $R_{MAX} = (2 / \# \text{ termination caps}) \times Q_{ACTUAL}$		

- S = 6" clearance from sides of electrical service
(See Note 5)
- T = 12" clearance above electrical service
(See Note 5)

** a vent shall not terminate directly above a sidewalk or paved driveway which is located between two single family dwellings and serves both dwellings.

*** only permitted if veranda, porch, deck or balcony is fully open on a minimum of 2 sides beneath the floor, or meets Note 2.

NOTE 1: On private property where termination is less than 7 feet above a sidewalk, driveway, deck, porch, veranda or balcony, use of a listed cap shield is suggested.

NOTE 2: Termination in an alcove space (spaces open only on one side and with an overhang) are permitted with the dimensions specified for vinyl or non-vinyl siding and soffits. **1.** There must be 3 feet minimum between termination caps. **2.** All mechanical air intakes within 10 feet of a termination cap must be a minimum of 3 feet below the termination cap. **3.** All gravity air intakes within 3 feet of a termination cap must be a minimum of 1 foot below the termination cap.

NOTE 3 Local codes or regulations may require different clearances.

NOTE 4: Termination caps may be hot. Consider their proximity to doors or other traffic areas.

NOTE 5: Location of the vent termination must not interfere with access to the electrical service.

WARNING: In the U.S: Vent system termination is **NOT** permitted in screened porches. You must follow side wall, overhang and ground clearances as stated in the instructions.

In Canada: Vent system termination is **NOT** permitted in screened porches. Vent system termination is permitted in porch areas with two or more sides open. You must follow all side walls, overhang and ground clearances as stated in the instructions.

Hearth & Home Technologies assumes no responsibility for the improper performance of the fireplace when the venting system does not meet these requirements.

◆ **Figure 19. Vent Termination Minimum Clearances**

CAUTION: IF EXTERIOR WALLS ARE FINISHED WITH VINYL SIDING, IT IS SUGGESTED THAT A VINYL PROTECTOR KIT BE INSTALLED.

For Vertical Terminations - To locate the vent and install the vent sections:

- Locate and mark the vent centerpoint on the underside of the roof, and drive a nail through the centerpoint.
- Make the outline of the roof hole around the centerpoint nail.
- The size of the roof hole framing dimensions depend on the pitch of the roof. There **MUST BE** a 1-inch (25.4mm) clearance from the vertical vent pipe to combustible materials.
- Mark the roof hole accordingly.
- Cover the opening of the installed vent pipes.
- Cut and frame the roof hole.
- Use framing lumber the same size as the roof rafters and install the frame securely. Flashing anchored to the frame must withstand heavy winds.
- Continue to install concentric vent sections up through the roof hole (for inside vent installations) or up past the roof line until you reach the appropriate distance above the roof (for outside terminations).

To seal the roof hole, and to divert rain and snow from the vent system:

- Attach a flashing to the roof using nails, and use a non-hardening mastic around the edges of the flashing base where it meets the roof.
- Attach a storm collar over the flashing joint to form a water-tight seal. Place non-hardening mastic around the joint, between the storm collar and the vertical pipe.
- Slide termination cap over the end of the vent pipe and secure with screws.

WARNING: MAJOR U.S. BUILDING CODES SPECIFY MINIMUM CHIMNEY AND/OR VENT HEIGHT ABOVE THE ROOF TOP. THESE MINIMUM HEIGHTS ARE NECESSARY IN THE INTEREST OF SAFETY. SEE THE FOLLOWING DIAGRAM FOR MINIMUM HEIGHTS, PROVIDED THE TERMINATION CAP IS AT LEAST 20 INCHES FROM A VERTICAL WALL AND 2-FEET BELOW A HORIZONTAL OVERHANG.

NOTE: This also pertains to vertical vent systems installed on the outside of the building.

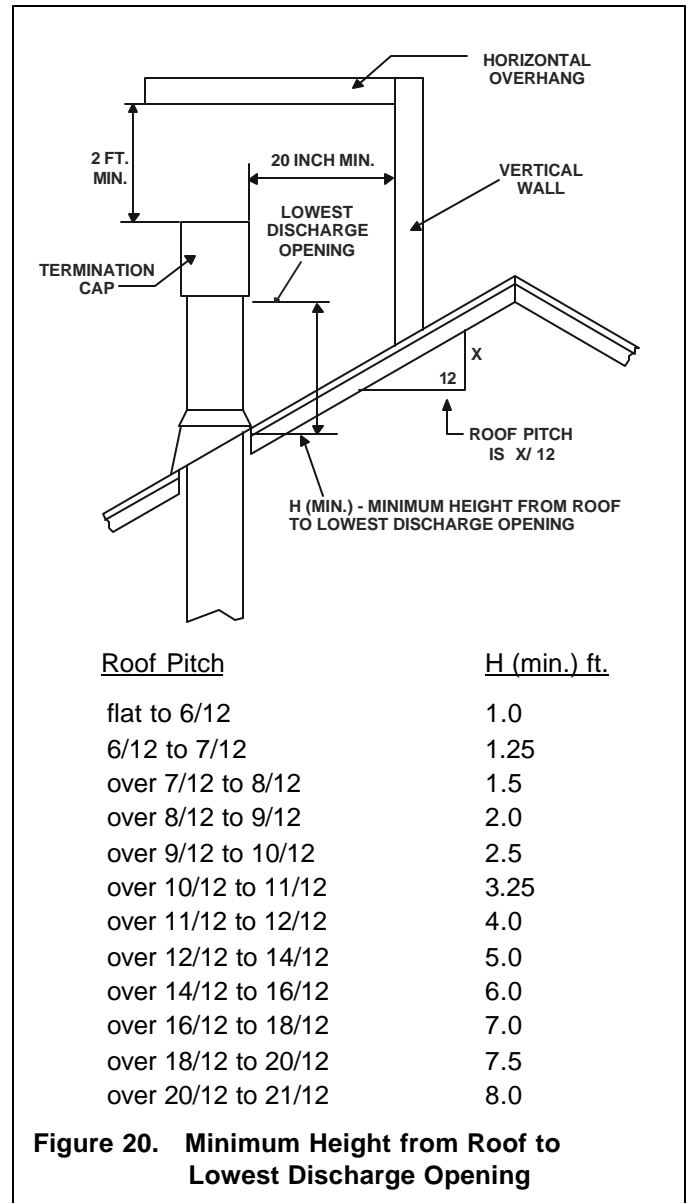

Step 4. Positioning, Leveling, and Securing the Fireplace

The diagram below shows how to properly position, level, and secure the fireplace.

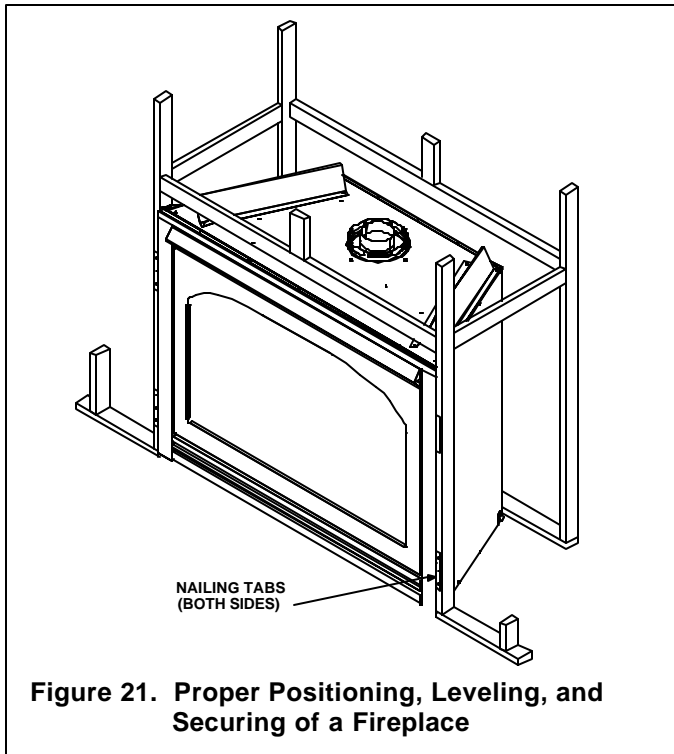

- Place the fireplace into position.
- Level the fireplace from side to side and from front to back.
- Shim the fireplace with non-combustible material, such as sheet metal, as necessary.
- Secure the fireplace to the framing by driving nails or screws through the nailing tabs.

Step 5. The Gas Control System



WARNING: THIS UNIT IS NOT FOR USE WITH SOLID FUEL.

Intermittent Pilot Ignition (IPI) System

The gas control system used with this model is *Intermittent Pilot Ignition (IPI)*. This system includes a 3V control valve, electronic module, and intermittent pilot.



WARNING: CONTINUOUS 110-120 VAC SERVICE MUST BE WIRED DIRECTLY TO THE FIREPLACE JUNCTION BOX.

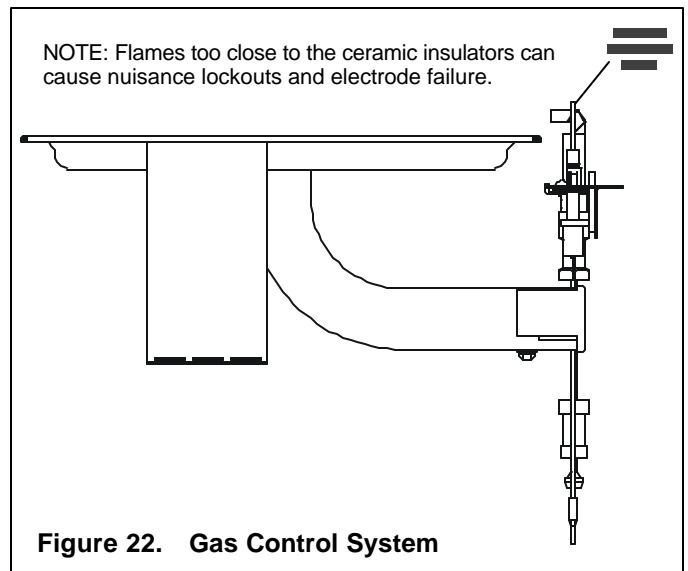

Step 6. The Gas Supply Line

NOTE: Have the gas supply line installed in accordance with local building codes by a qualified installer approved and/or licensed as required by the locality. (In the Commonwealth of Massachusetts installation must be performed by a licensed plumber or gas fitter).

NOTE: Before the first firing of the fireplace, the gas supply line should be purged of any trapped air.

NOTE: Consult local building codes to properly size the gas supply line leading to the 1/2 inch (13 mm) hook-up at the unit.

This gas fireplace is designed to accept a 1/2 inch (13 mm) gas supply line.

To install the gas supply line:

- A listed (and Commonwealth of Massachusetts approved) 1/2 inch (13mm) tee-handle manual shut-off valve and a listed flexible gas connector are connected to the 1/2 inch (13mm) inlet of the control valve. **NOTE:** If substituting for these components, please consult local codes for compliance.
- Locate the gas line access hole in the outer casing of the fireplace.
- Insert the gas supply line through the gas line hole, and connect it to the shut-off valve.
- When attaching the pipe, support the control so that the lines are not bent or torn.
- ◆ After the gas line installation is complete, all connections must be tightened and checked for leaks with a commercially-available, non-corrosive leak check solution. Be sure to rinse off all leak check solution following testing.



WARNING: DO NOT USE AN OPEN FLAME TO CHECK FOR GAS LEAKS.

- At the gas line access hole, use insulation to re-pack the space around the gas pipe.
- Insert insulation from the outside of the fireplace and pack the insulation tightly to totally seal between the pipe and the outer casing.

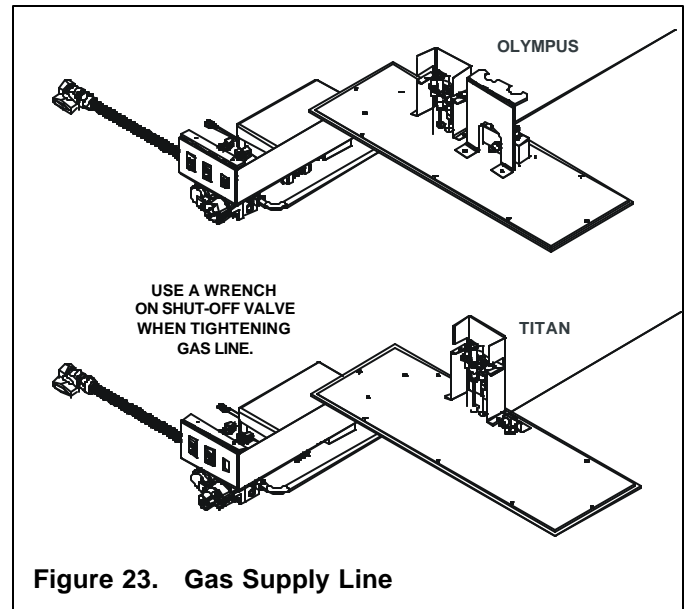

Figure 23. Gas Supply Line

Step 7. Gas Pressure Requirements

Pressure requirements for these Hearth & Home Technologies gas fireplaces are shown in the table below.

Pressure	Natural Gas	Propane
Minimum Inlet Pressure	5.0 in. w.c. (Olympus) 7.0 in. w.c. (Titan)	11.0 inches w.c.
Maximum Inlet Gas Pressure	14.0 inches w.c.	14.0 inches w.c.
Manifold Pressure	3.5 inches w.c.	10.0 inches w.c.

Connections are provided on the front of the gas control valve for both inlet and manifold pressures. To use these the valve cover must be removed and the small slotted screw inside the pressure tap loosened. Manifold pressure should be checked with main burner turned on and rear log off. *This screw must be retightened carefully after pressure gauge is removed to avoid a gas leak.*

The fireplace and its individual shut-off valve must be disconnected from the gas supply piping system during any pressure testing of the system at test pressures in excess of one-half (1/2) psig (3.5 kPa).

The fireplace must be isolated from the gas supply piping system by closing its individual shut-off valve during any pressure testing of the gas supply piping system at test pressures equal to or less than one-half (1/2) psig (3.5 kPa).

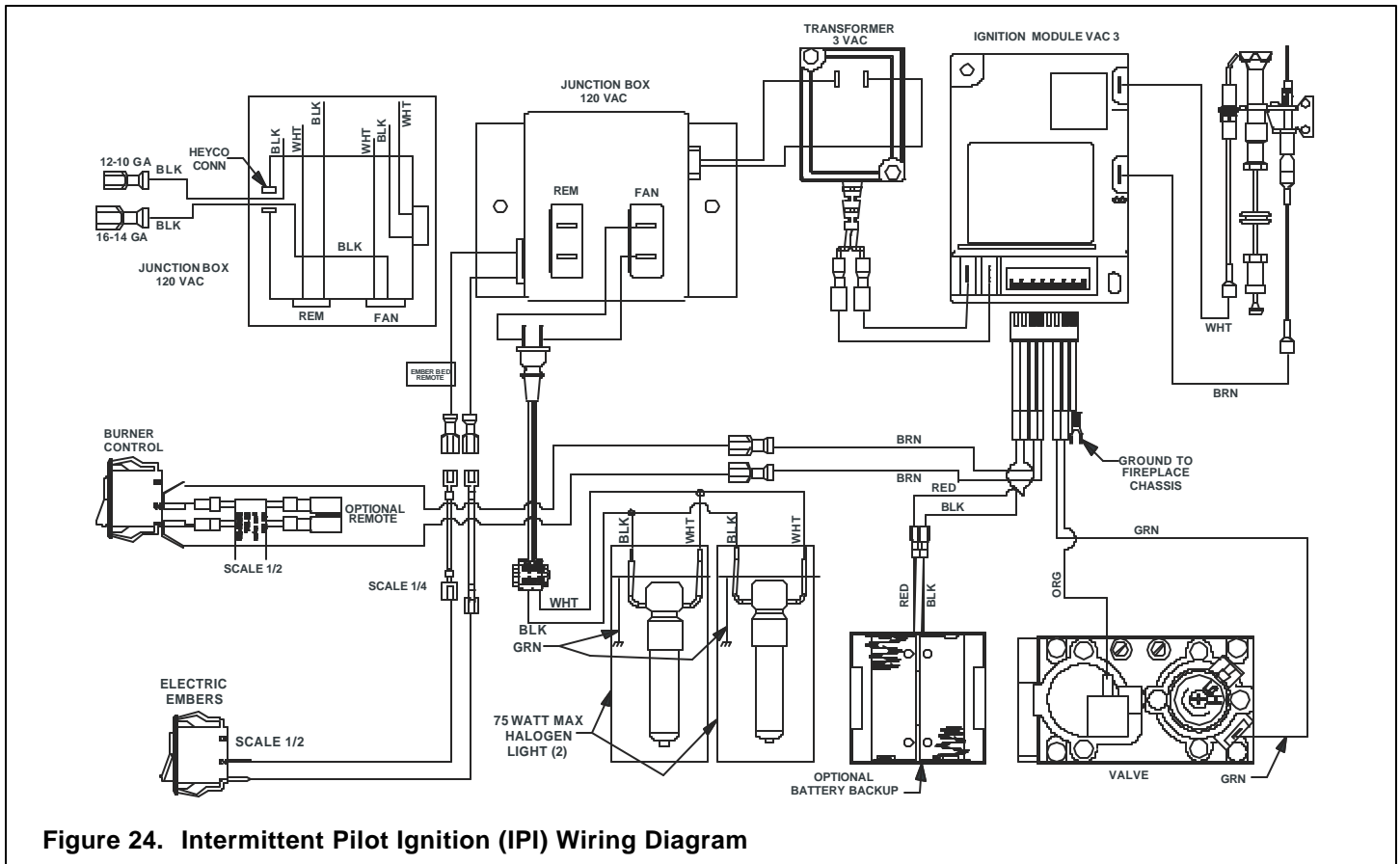

Figure 24. Intermittent Pilot Ignition (IPI) Wiring Diagram

Step 8. Wiring the Fireplace

NOTE: Electrical wiring must be installed by a licensed electrician.

CAUTION: DISCONNECT REMOTE CONTROLS BY UNPLUGGING FROM THE JUNCTION BOX IF ABSENT FOR EXTENDED TIME PERIODS. THIS WILL PREVENT ACCIDENTAL FIREPLACE OPERATION.

For Intermittent Pilot Ignition (IPI) Wiring Appliance Requirements

This appliance requires that 110-120 VAC be wired to the factory installed junction box. Maintain correct polarity when wiring the junction box.

Remove transformer from shipping position by cutting and removing cable tie.

Plug transformer into side of junction box.

Optional Accessories

Optional fan and remote control kits require that 110-120 VAC be wired to the factory installed junction box before the fireplace is permanently installed. Note: Use of the GFK-160A fan kit requires either the WSK-MLT wall switch kit, or the RCT-MLT-HNG (Olympus)/RCT-MLT-HTL (Titan) remote control kit. The GFK-160A plugs into the remote control module. The remote control module then plugs into REM on the junction box.

CAUTION: LABEL ALL WIRES PRIOR TO DISCONNECTION WHEN SERVICING CONTROLS. WIRING ERRORS CAN CAUSE IMPROPER AND DANGEROUS OPERATION. VERIFY PROPER OPERATION AFTER SERVICING.

WARNING

Wire 110V to electrical junction box.
Do NOT wire 110V to valve.
Do NOT wire 110V to wall switch.

- Incorrect wiring will damage millivolt valves.
- Uninterrupted or continuous power is required at all times in IPI system EXCEPT when using battery back-up.

• Incorrect wiring will override IPI safety lockout and may cause explosion.

Intensifire Switch (Olympus Only)

This model is equipped with an intensifire switch. This switch allows you to turn On/Off the rear log burners. The switch is located on the control panel. Install the 9 volt battery into the battery holder located in the lower compartment right next to the control panel (see Figure 25).

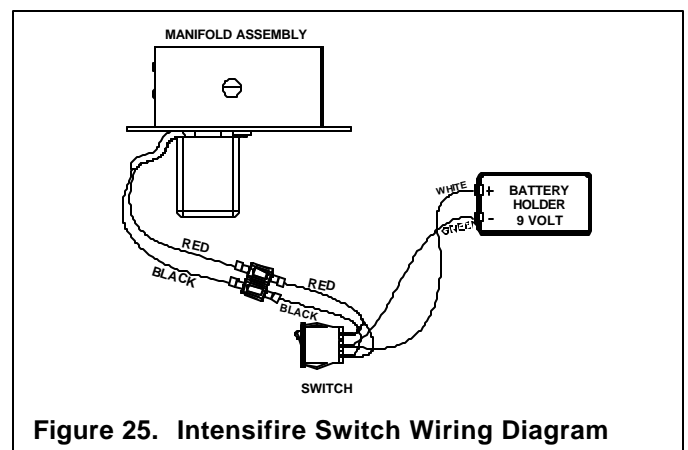

Figure 25. Intensifire Switch Wiring Diagram

Step 9. Finishing

Figure 26 shows the minimum vertical and corresponding maximum horizontal dimensions of fireplace mantels or other combustible projections above the top front edge of the fireplace. See Figures 3 and 4 for other fireplace clearances.

Only non-combustible materials may be used to cover the black fireplace front.

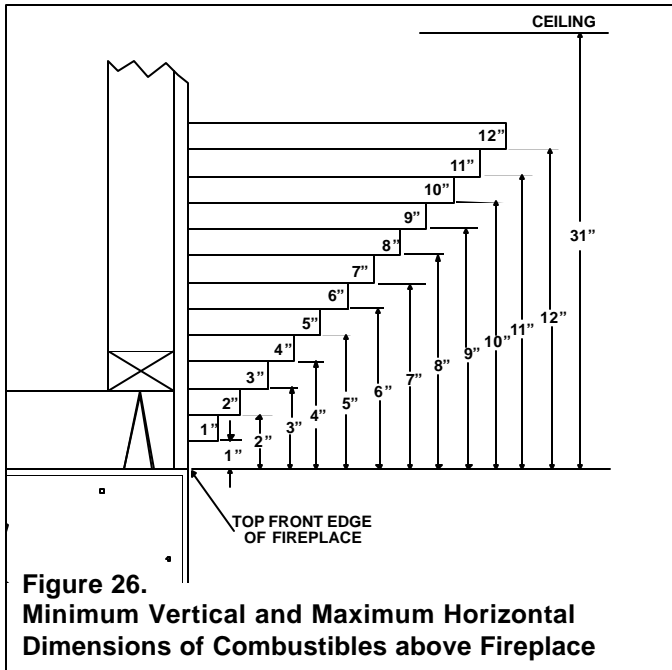

Figure 26.
Minimum Vertical and Maximum Horizontal Dimensions of Combustibles above Fireplace

WARNING: WHEN FINISHING THE FIREPLACE, NEVER OBSTRUCT OR MODIFY THE AIR INLET/OUTLET GRILLES IN ANY MANNER.

CAUTION: IF JOINTS BETWEEN THE FINISHED WALLS AND THE FIREPLACE SURROUND (TOP AND SIDES) ARE SEALED, A 300° F. MINIMUM SEALANT MATERIAL MUST BE USED. THESE JOINTS ARE NOT REQUIRED TO BE SEALED. ONLY NON-COMBUSTIBLE MATERIAL (USING 300° F. MINIMUM ADHESIVE, IF NEEDED) CAN BE APPLIED AS FACING TO THE FIREPLACE SURROUND. SEE THE DIAGRAM BELOW.

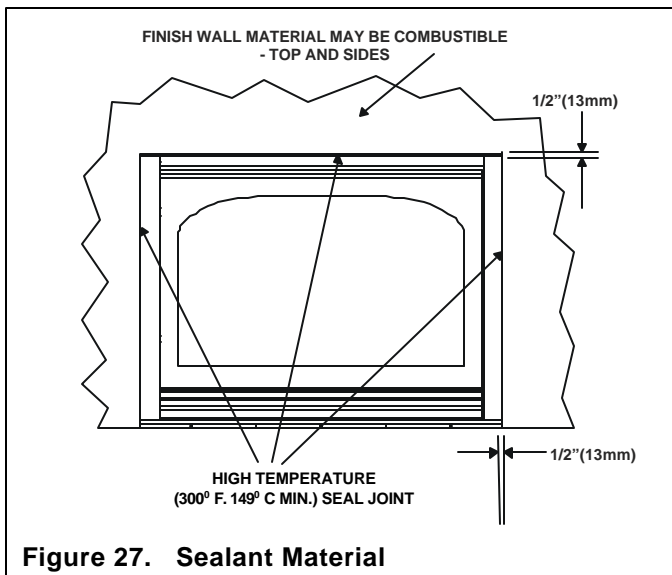

Figure 27. Sealant Material

Hearth Extensions

A hearth extension may be desirable for aesthetic reasons. However, ANSI or CAN/CGA testing standards **do not** require hearth extensions for gas fireplace appliances.

Step 10. Installing Trim, Refractory, Logs and Ember Material

Installing the Trim

Combustible materials may be brought up to the specified clearances on the side and top front edges of the fireplace, but **MUST NEVER** overlap onto the front face. The joints between the finished wall and the fireplace top and sides can only be sealed with a 300° F. (149° C) minimum sealant.



WARNING: WHEN FINISHING THE FIREPLACE, NEVER OBSTRUCT OR MODIFY THE AIR INLET/OUTLET GRILLES IN ANY MANNER.

Install optional marble and brass trim surround kits as desired. Marble, brass, brick, tile, or other non-combustible materials can be used to cover up the gap between the sheet rock and the fireplace.

When overlapping on both sides, leave enough space so decorative door is accessible.

Positioning the Refractory

The refractory has been packaged separately, refer to the instructions included.

Positioning the Logs

The logs have been packaged separately, refer to the instructions included. **Save the log instructions with this manual.**

If sooting occurs, the logs might need to be repositioned slightly to avoid excessive flame impingement.

Placing the Ember Material

Ember material is shipped with this gas fireplace. To place the ember material:

- Place dime size pieces of ember material about 1/2 inch apart near port holes in burner top. Do NOT press embers into burner ports. Care should be taken so that the ports are not covered.
- Save the remaining ember materials for use during fireplace servicing.
- Use of ember material is optional.

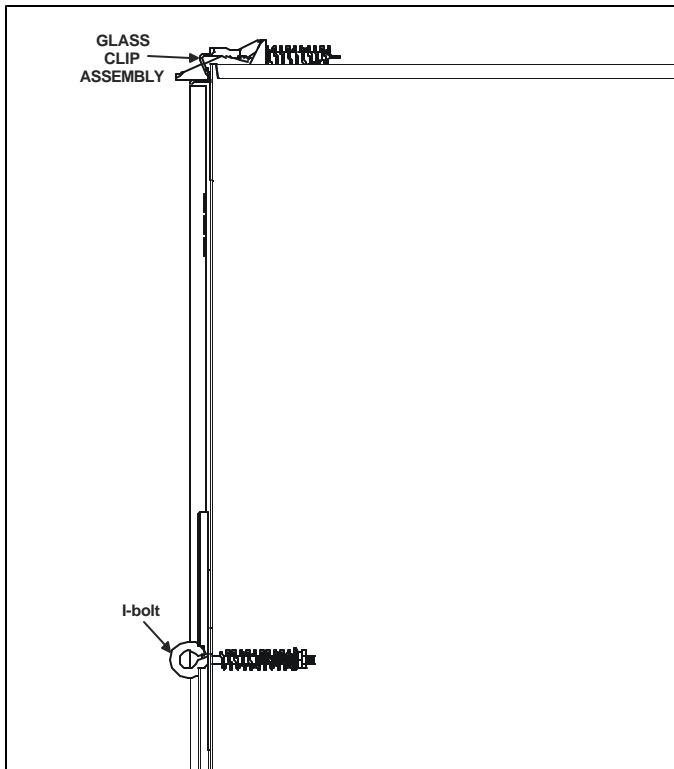

Figure 28. Glass Assembly

- Glass can now be reinstalled, followed by glass clips and I-bolts (see Figure 28). I-bolts can be fastened by using a special hook tool that is shipped with the fireplace. Finish the installation by installing decorative door.

Note: When removing or replacing the glass, use the special hook tool provided with the fireplace to turn the I-bolts to a 45° angle for ease of operation. The I-bolts can then be moved through the slots in the glass frame with the special hook tool provided. Make sure the I-bolts end up in the orientation shown in Figure 28 when installation is complete.

Glass Specifications

OLYMPUS and TITAN TEMPERED GLASS

Hearth and Home Technologies fireplaces manufactured with tempered glass may be installed in hazardous locations such as bathtub enclosures as defined by the CPSC. The tempered glass has been tested and certified to the requirements of ANSI Z97.1-1984 and CPSC 16 CFR 1202. (Safety Glazing Certification Council SGCC # 1595 and 1597. Architectural Testing, Inc. Reports 02-31919.01 and 02-31917.01.)

This statement is in compliance with CPSC 16 CFR Section 1201.5 “Certification and labeling requirements” which refers to 15 USC 2063 stating “...Such certificate shall accompany the product or shall otherwise be furnished to any distributor or retailer to whom the product is delivered.”

Some local building codes require the use of tempered glass with permanent marking in such locations. Glass meeting this requirement is available from the factory. Please contact your dealer or distributor to order.

Step 11. Before Lighting the Fireplace

BEFORE lighting the fireplace, be sure to do the following:

- **Remove** all paperwork from underneath the fireplace.
- **Review** all cautions, and Safety and Warnings section at the beginning of this Installers Guide.
- **Double-check** the unit for possible gas leaks.
- **Double-check** the unit for possible obstructions that could be blocking the vent terminations.
- **Double-check** for faulty components: Any component that is found to be faulty **MUST BE** replaced with an approved component. Tampering with the fireplace components is **DANGEROUS** and voids all warranties.

A small amount of air will be in the gas supply lines. When first lighting the fireplace, it will take a few minutes for the lines to purge themselves of this air. Once the purging is complete, the fireplace will light and will operate normally.

Subsequent lightings of the fireplace will not require this purging of air from the gas supply lines, **unless the gas valve has been turned to the OFF position**, in which case the air could have to be purged again.

NOTE: The fireplace should be run 3 to 4 hours on the initial start-up. Turn it off and let it cool completely. Remove and clean the glass. Replace the glass and run the fireplace for an additional 8 hours. This will help to cure the products used in the paint and logs.

During this break-in period it is recommended that some windows in the house be opened for air circulation. This will help avoid setting off smoke detectors, and help eliminate any odors associated with the fireplace's initial burning.

Step 12. Lighting the Fireplace

After reviewing all safety warnings, checking the fireplace for gas leaks, checking that the vent system is unobstructed, and checking for faulty components, be sure power is on and proceed with lighting fireplace.

FOR YOUR SAFETY READ BEFORE LIGHTING

WARNING: IF YOU DO NOT FOLLOW THESE INSTRUCTIONS EXACTLY, A FIRE OR EXPLOSION MAY RESULT CAUSING PROPERTY DAMAGE, PERSONAL INJURY, OR LOSS OF LIFE.

IPI IGNITION

- A. This appliance is equipped with an intermittent pilot ignition (IPI) device which automatically lights the burner. Do not try to light the burner by hand.
- B. **BEFORE OPERATING** smell all around the appliance area for gas. Be sure to smell next to the floor because some gas is heavier than air and will settle to the floor.

WHAT TO DO IF YOU SMELL GAS

- Do not try to light any appliance.
 - Do not touch any electric switch; do not use any phone in your building.
 - Immediately call your gas supplier from a neighbor's phone. Follow the gas supplier's instructions.
 - If you cannot reach your gas supplier, call the fire department.
- C. Do not use this appliance if any part has been under water. Immediately call a qualified service technician to inspect the appliance and to replace any part of the control system and any gas control which has been under water.

When you light your fireplace for the first time, you may notice:

- This gas appliance produces heat which does have an associated odor or smell. If you feel this odor is excessive it may require the initial 3-4 hour continuous burn on high followed by a second burn of up to 12 hours to fully drive off any odor from paint and lubricants used in the manufacturing process. Additionally, for the first few minutes after each lighting, vapor may condense and fog the glass and flames may be blue. After a few minutes this moisture will disappear and within 15-30 minutes the flames should become yellow.

LIGHTING INSTRUCTIONS (IPI)

1. **STOP!** Read the safety information on page 9 first!
2. Turn off all electric power to the appliance.
3. This appliance is equipped with an ignition device which automatically lights the burner. Do not try to light the burner by hand.

GAS
VALVE

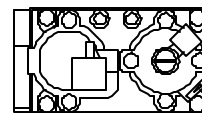

4. Wait five (5) minutes to clear out any gas. Then smell for gas, including near the floor. If you smell gas, **STOP!** Follow "B" in the Safety Information located on the previous pages. If you don't smell gas, go to next step.
5. Turn on all electric power to the appliance.
- 6 To light the burner, flip the ON/OFF switch to the "ON" position. (The ON/OFF switch may include a wall switch if so equipped).
7. If the appliance will not operate, follow the instructions "To Turn Off Gas to Appliance" and call your service technician or gas supplier.

TO TURN OFF GAS TO APPLIANCE

1. Turn off all electric power to the appliance if service is to be performed.
2. Flip ON/OFF switch to the "OFF" position.

During the break-in period it is recommended that some windows in the house be opened for air circulation. This will help avoid setting off smoke detectors, and help eliminate any odors associated with the fireplace's initial burning.

- Noise caused by metal expanding and contracting as it heats up and cools down, similar to the sound produced by a furnace or heating duct. This noise does not affect the operation or longevity of your fireplace.

After the Installation



LEAVE THIS INSTALLATION MANUAL WITH THE APPLIANCE FOR FUTURE REFERENCE.

4

Maintaining and Servicing Your Fireplace

Fireplace Maintenance

Although the frequency of your fireplace servicing and maintenance will depend on use and the type of installation, you should have a qualified service technician perform an appliance check-up at the beginning of each heating season. See the table below for specific guidelines regarding each fireplace maintenance task.

IMPORTANT: TURN OFF THE GAS BEFORE SERVICING YOUR FIREPLACE.

Replacing old ember material

Frequency: Once annually, during the checkup.

By: Qualified service technician.

Task: Brush away loose ember material near the burner. Replace old ember material with new dime-size and shape pieces of Golden Ember (DE-93) and Glowing Ember (050-721). Save the remaining ember material and repeat this procedure at your next servicing. For more information, see **Placing Ember Material**.

Cleaning Burner and Controls

Frequency: Once annually.

By: Qualified service technician.

Task: Brush or vacuum the control compartment, fireplace logs and burner areas surrounding the logs.

Cleaning Flame Sensor Rod (IPI Systems)

Frequency: Annually.

By: Qualified service technician.

Task: Make a visual check of the straight flame sensor rod (see Figure 22). Use emery cloth to carefully remove any existing film or white deposits.

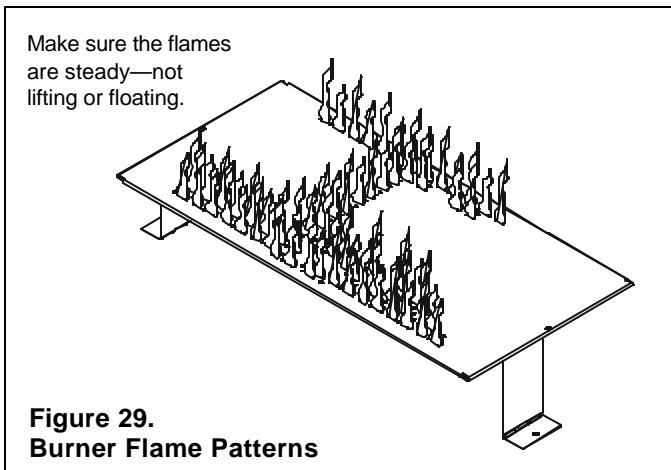

Checking Flame Patterns, Flame Height

Frequency: Periodically.

By: Qualified service technician/Home owner.

Task: Make a visual check of your fireplace's flame patterns. Make sure the flames are steady - not lifting or floating. See Figure 29. The flame sensor tips should be covered with flame. See Figure 22.

Checking Vent System

Frequency: Before initial use and at least annually thereafter, more frequently if possible.

By: Qualified service technician/Home owner.

Task: Inspect the external vent cap on a regular basis to ensure that no debris is interfering with the flow of air. Inspect entire vent system for proper function.

Cleaning Glass Door

Frequency: After the first 3 to 4 hours of use. As necessary after initial cleaning.

By: Home owner.

Task: Remove and clean glass after the first 3 to 4 hours of use. After the initial cleaning, clean as necessary, particularly after adding new ember (flame colorant) material. Film deposits on the inside of the glass door should be cleaned off using a household glass cleaner. **NOTE: DO NOT handle or attempt to clean the door when it is hot and DO NOT use abrasive cleaners.**

Recommended Bulbs

Frequency: Periodically. Sylvania mini Candelabra 75W Halogen bulbs are recommended for use in the appliance.

By: Home owner

Task: To replace light bulb

1. Turn off fireplace and electric embers and allow to cool (min. 6 hrs.).
2. Remove the screws holding the panel in place and pull out bulb housing.
3. Replace bulb. See installation instructions on bulb packaging for details on changing the halogen bulb.
4. Replace bulb housing making sure to not touch the bulb or have the bulb touch the firebox.
5. Tighten the screws to anchor the panel in place.

5

IPI Troubleshooting

With proper installation, operation, and maintenance your gas fireplace will provide years of trouble-free service. If you do experience a problem, this troubleshooting guide will assist a qualified service person in the diagnosis of a problem and the corrective action to be taken. This troubleshooting guide can only be used by a qualified service technician.

Symptom	Possible Cause	Corrective Action
1. Nothing happens when ON/OFF switch is turned on (pilot does not spark).	a. Low voltage/or bad lead wires.	Check voltage on AC terminals of module: should read 2.8 to 3.2 VAC. Check and/or replace batteries. Confirm wire connections are secure.
	b. Faulty pilot device.	Gap between electrode and pilot hood should be approx. 3/16". Check pilot for damage (cracked insulator on spark electrode, etc.).
	c. Faulty igniter wire.	Check wire for cracked casing, cuts, shorts, etc.
2. The main burner does not light and the igniter is sparking.	a. Loose sensor or spark wire.	Ensure spark and sensor wires are connected.
	b. No fuel supply.	Ensure that gas shut off is turned on. Ensure the fuel supply is properly connected.
	c. Air in gas line.	Purge gas line of air.
	d. Loose orange wire to valve.	Connect wire to orange terminal on valve.
	e. Black controller wire not connected to ground.	Connect black wire to ground.
	f. Flame sensor not in pilot flame.	Determine cause of improper flame on the sensor, replace if necessary.
	g. Loose green wire to valve.	Connect green wire to valve.
	h. Low voltage.	Test voltage at battery terminals (red and black wires). If it is not at least 2.7 VAC, find source of low voltage problem (replace batteries or 3V adapter).
	i. Faulty module or valve.	Check all wire connections including the ground wire. If OK then remove green wire from valve with the pilot lit. Connect a wire from red battery connection (red wire) to green terminal of valve. If valve opens and burner lights, replace the module. If it does not, replace the valve.
3. Pilot stays lit (should turn off when ON/OFF is turned off).	a. Loose connection on green wire.	Check connection of green wire to green terminal on valve.
	b. Faulty valve.	Disconnect orange wire on valve. If the pilot remains lit replace faulty valve.
	c. Faulty module.	Disconnect orange wire on valve. If the pilot turns off then check all connections and continuity - if no fault is found in wiring then replace faulty module.
4. The main burner extinguishes while in operation.	a. No fuel supply	Check fuel supply and connections to LP tank.
	b. Loose wire connection on module or valve.	Check wire connections.
	c. High temperature limit switch where applicable.	Replace high temperature limit switch.
	d. Flame does not engulf flame sensor	Check location of sensor.
	e. Glass too loose and air tight gasket leaks in corners after usage.	Remove glass, inspect corners and tighten gasket if applicable.
	f. Inner vent pipe leaking exhaust gases back into the system.	Check for leaks.
	g. Improper vent cap installation.	Check for proper installation and freedom from debris or blockage.
5. The glass soots.	a. Improper venturi setting.	Adjust the air shutter at the base of the burner.
	b. Too much flame impingement on the log	Check for proper log placement.
6. The flame burns blue and lifts off the burner.	a. Insufficient oxygen being supplied.	Ensure that the vent cap is installed properly and free of debris. Ensure that the inner vent pipe has no leaks in it. Ensure that the glass is tightened properly on the unit, particularly on top corners.