

This appliance has been retired.  
Service parts pages within have been removed.  
For replacement parts, please refer to the individual  
service parts list located on the brand websites.

**HEAT-N-GLO**  
No one builds a better fire

**Model:  
CFX-DIAMOND**

**Installers Guide**

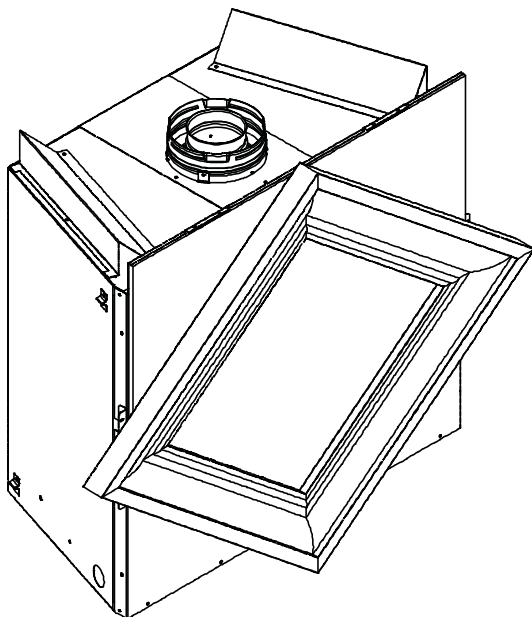

**UL** US  
**LISTED**  
Underwriters  
Laboratories Listed

**WARNING: IF THE INFORMATION IN THESE INSTRUCTIONS IS NOT FOLLOWED EXACTLY, A FIRE OR EXPLOSION MAY RESULT CAUSING PROPERTY DAMAGE, PERSONAL INJURY, OR DEATH.**

- Do not store or use gasoline or other flammable vapors and liquids in the vicinity of this or any other appliance.
- **What to do if you smell gas**
  - Do not try to light any appliance.
  - Do not touch any electrical switch.
  - Do not use any phone in your building.
  - Immediately call your gas supplier from a neighbor's phone. Follow the gas supplier's instructions.
  - If you cannot reach your gas supplier, call the fire department.
- Installation and service must be performed by a qualified installer, service agency, or the gas supplier.

**READ THIS MANUAL BEFORE INSTALLING OR OPERATING THIS APPLIANCE. THIS *INSTALLERS GUIDE* MUST BE LEFT WITH APPLIANCE FOR FUTURE REFERENCE.**

**WARNING: IMPROPER INSTALLATION, ADJUSTMENT, ALTERATION, SERVICE OR MAINTENANCE CAN CAUSE INJURY OR PROPERTY DAMAGE. REFER TO THIS MANUAL. FOR ASSISTANCE OR ADDITIONAL INFORMATION CONSULT A QUALIFIED INSTALLER, SERVICE AGENCY, OR THE GAS SUPPLIER.**

1. This appliance may be installed in an aftermarket, permanently located, manufactured (mobile) home, where not prohibited by local codes.
2. This appliance is only for use with the type of gas indicated on the rating plate. This appliance is not convertible for use with other gases, unless a certified kit is used.

Printed in U.S.A. Copyright 2002,  
Heat-N-Glo, a division of Hearth Technologies Inc.  
20802 Kensington Boulevard, Lakeville, MN 55044

Please contact your Heat-N-Glo dealer with any questions or concerns. For the number of your nearest Heat-N-Glo dealer, please call 1-888-427-3973.

This product is covered by one or more of the following patents: (United States) 4,112,913; 4,408,594; 4,422,426; 4,424,792; 4,520,791; 4,793,322; 4,852,548; 4,875,464; 5,000,162; 5,016,609; 5,076,254; 5,191,877; 5,218,953; 5,328,356; 5,429,495; 5,452,708; 5,542,407; 5,613,487; (Australia) 543790; 586383; (Canada) 1,123,296; 1,297,746; 2,195,264; (Mexico) 97-0457; (New Zealand) 200265; or other U.S. and foreign patents pending.

593-900H 8/02

## SAFETY AND WARNING INFORMATION



**READ** and **UNDERSTAND** all instructions carefully before starting the installation. **FAILURE TO FOLLOW** these installation instructions may result in a possible fire hazard and will void the warranty.



Prior to the first firing of the fireplace, **READ** the Using Your Fireplace section of the *Owners Guide*.



**DO NOT USE** this appliance if any part has been under water. Immediately **CALL** a qualified service technician to inspect the unit and to replace any part of the control system and any gas control which has been under water.



**THIS UNIT IS NOT FOR USE WITH SOLID FUEL.**



Installation and repair should be **PERFORMED** by a qualified service person. The appliance and venting system should be **INSPECTED** before initial use and at least annually by a professional service person. More frequent cleaning may be required due to excessive lint from carpeting, bedding material, etc. It is **IMPERATIVE** that the unit's control compartment, burners, and circulating air passageways **BE KEPT CLEAN** to provide for adequate combustion and ventilation air.



Always **KEEP** the appliance clear and free from combustible materials, gasoline, and other flammable vapors and liquids.



**NEVER OBSTRUCT** the flow of combustion and ventilation air. Keep the front of the appliance **CLEAR** of all obstacles and materials for servicing and proper operations.



Due to the high temperature, the appliance should be **LOCATED** out of traffic areas and away from furniture and draperies. Clothing or flammable material **SHOULD NOT BE PLACED** on or near the appliance.



Children and adults should be **ALERTED** to the hazards of high surface temperature and should **STAY AWAY** to avoid burns or clothing ignition. Young children should be **CAREFULLY SUPERVISED** when they are in the same room as the appliance.



These units **MUST** use one of the vent systems described in the Installing the Fireplace section of the *Installers Guide*. **NO OTHER** vent systems or components **MAY BE USED**.



This gas fireplace and vent assembly **MUST** be vented directly to the outside and **MUST NEVER** be attached to a chimney serving a separate solid fuel burning appliance. Each gas appliance **MUST USE** a separate vent system. Common vent systems are **PROHIBITED**.



**INSPECT** the external vent cap on a regular basis to make sure that no debris is interfering with the air flow.



The glass door assembly **MUST** be in place and sealed, and the trim door assembly **MUST** be in place on the fireplace before the unit can be placed into safe operation.



**DO NOT OPERATE** this appliance with the glass door removed, cracked, or broken. Replacement of the glass door should be performed by a licensed or qualified service person. **DO NOT** strike or slam the glass door.



The glass door assembly **SHALL ONLY** be replaced as a complete unit, as supplied by the gas fireplace manufacturer. **NO SUBSTITUTE** material may be used.



**DO NOT USE** abrasive cleaners on the glass door assembly. **DO NOT ATTEMPT** to clean the glass door when it is hot.



Turn off the gas before servicing this appliance. It is recommended that a qualified service technician perform an appliance check-up at the beginning of each heating season.



Any safety screen or guard removed for servicing must be replaced before operating this appliance.



**DO NOT** place furniture or any other combustible household objects within 36 inches of the fireplace front.

## Table of Contents

<b>Safety and Warning Information .....</b>	<b>2</b>
<b>◆ Service Parts .....</b>	<b>4</b>
<b>Section 1: Approvals and Codes .....</b>	<b>6</b>
Appliance Certification .....	6
Installation Codes .....	6
High Altitude Installations .....	6
<b>Section 2: Getting Started .....</b>	<b>7</b>
Introducing the Heat-N-Glo Gas Fireplaces .....	7
Pre-installation Preparation .....	7
<b>Section 3: Installing the Fireplace .....</b>	<b>9</b>
Constructing the Chase .....	9
Step 1 Locating the Fireplace .....	10
Step 2 Framing the Fireplace .....	11
Step 3 Installing the Vent System .....	12
A. Vent System Approvals .....	12
B. Installing Vent Components .....	18
◆ C. Vent Termination .....	23
Step 4 Positioning, Leveling, and Securing the Fireplace .....	28
Step 5 The Gas Control Systems .....	28
Step 6 The Gas Supply Line .....	29
Step 7 Gas Pressure Requirements .....	30
Step 8 Wiring the Fireplace .....	31
Step 9 Finishing .....	32
Step 10 Installing Trim, Logs & Ember Material ...	34
Installing the Trim .....	34
Shutter Settings .....	34
Positioning the Logs .....	35
Placing the Ember Material .....	35
Step 11 Before Lighting the Fireplace .....	37
Step 12 Lighting the Fireplace .....	37
After the Installation .....	37
<b>Section 4: Maintaining and Servicing     Your Fireplace .....</b>	<b>38</b>

◆ = Contains updated information.

# 1

## Approvals and Codes

### Approval Listings and Codes

### Appliance Certification

The Heat-N-Glo fireplace model discussed in this *Installers Guide* has been tested to certification standards and listed by the applicable laboratories.

MODEL	LABORATORY	TYPE	CERTIFICATION STANDARD
CFX-DIAMOND	Underwriters Laboratories	Direct Vent Gas Fireplace Heater	ANSI Z21.88 -2000/ CSA 2.33-M98 • UL307B

### Installation Codes

The fireplace installation must conform to local codes. Before installing the fireplace, consult the local building code agency to ensure that you are in compliance with all applicable codes, including permits and inspections.

In the absence of local codes, the fireplace installation must conform to the National Fuel Gas Code ANSI Z223.1 (in the United States) or the CAN/CGA-B149 Installation Codes (in Canada). The appliance must be electrically grounded in accordance with local codes or, in the absence of local codes with the National Electric Code ANSI/NFPA No. 70 (in the United States), or to the CSA C22.1 Canadian Electric Code (in Canada).

These models may be installed in a bedroom or bed-sitting room in the U.S.A. and Canada.

### High Altitude Installations

UL Listed gas fireplaces are tested and approved for elevations from 0 to 2,000 feet in the U.S.A., and from 0 to 4,500 feet in Canada.

When installing this fireplace at an elevation above 2,000 feet (in the United States), it may be necessary to decrease the input rating by changing the existing burner orifice to a smaller size. Input should be reduced four percent (4%) for each 1,000 feet above sea level, unless the heating value of the gas has been reduced, in which case this general rule will not apply. To identify the proper orifice size, check with the local gas utility.

When installing this fireplace at an elevation between 2,000 and 4,500 feet (in Canada), the input rating must be reduced by ten percent (10%).

When installing this fireplace at an elevation above 4,500 feet (in Canada), check with local authorities.

Consult your local gas utility for assistance in determining the proper orifice for your location.

## Introducing the Heat-N-Glo Fireplaces

Heat-N-Glo direct vent gas fireplaces are designed to operate with all combustion air siphoned from outside of the building and all exhaust gases expelled to the outside.

The information contained in this *Installers Guide*, unless noted otherwise, applies to all models and gas control systems.

Gas fireplace diagrams, including the dimensions, are shown in this section.

## Pre-installation Preparation

This gas fireplace and its components are tested and safe when installed in accordance with this *Installers Guide*. Report to your dealer any parts damaged in shipment, particularly the condition of the glass. **Do not install any unit with damaged, incomplete, or substitute parts.**

The vent system components are shipped in separate packages. The gas logs are packaged separately and must be field installed. **Read all of the instructions before starting the installation. Follow these instructions carefully during the installation to ensure maximum safety and benefit. Failure to follow these instructions will void the owner's warranty and may present a fire hazard.**

The Heat-N-Glo Warranty will be voided by, and Heat-N-Glo disclaims any responsibility for, the following actions:

- Installation of any damaged fireplace or vent system component.
- Modification of the fireplace or direct vent system.
- Installation other than as instructed by Heat-N-Glo.
- Improper positioning of the gas logs or the glass door.
- Installation and/or use of any component part not manufactured and approved by Heat-N-Glo, not withstanding any independent testing laboratory or other party approval of such component part or accessory.

**ANY SUCH ACTION MAY POSSIBLY CAUSE A FIRE HAZARD.**

# 2

## Getting Started

When planning a fireplace installation, it's necessary to determine:

- Where the unit is to be installed.
- The vent system configuration to be used.
- Gas supply piping.
- Electrical wiring.
- Framing and finishing details.
- Whether optional accessories—devices such as a wall switch, or remote control—are desired.

If the fireplace is to be installed on carpeting or tile, or on any combustible material other than wood flooring, the fireplace should be installed on a metal or wood panel that extends the full width and depth of the fireplace.

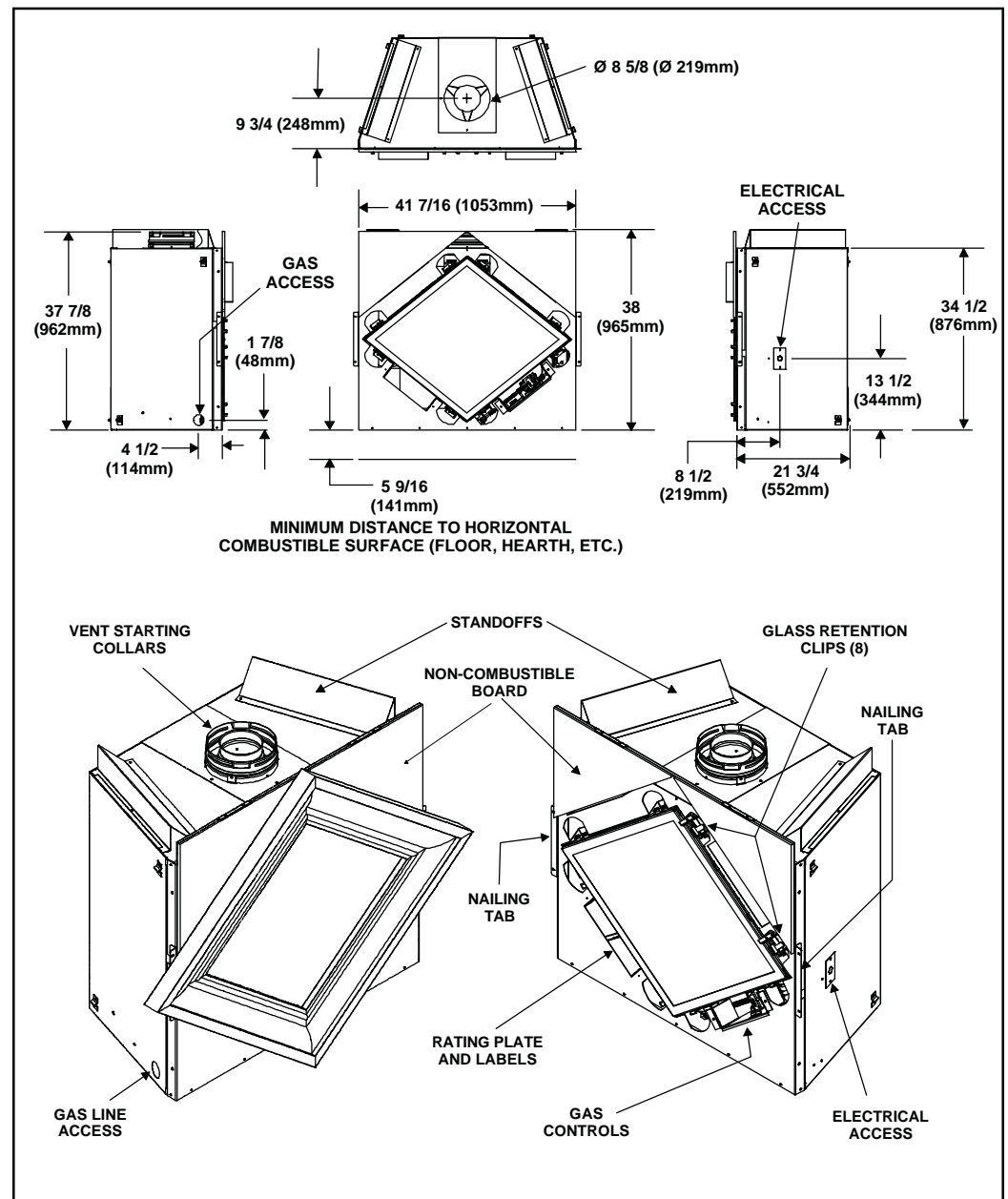

Figure 1. Diagram of the CFX-DIAMOND

# 3

## Installing the Fireplace

### Constructing the Fireplace Chase

A chase is a vertical box-like structure built to enclose the gas fireplace and/or its vent system. Vertical vents that run on the outside of a building may be, but are not required to be, installed inside a chase.

#### **CAUTION:**

*TREATMENT OF FIRESTOP SPACERS AND CONSTRUCTION OF THE CHASE MAY VARY WITH THE TYPE OF BUILDING. THESE INSTRUCTIONS ARE NOT SUBSTITUTES FOR THE REQUIREMENTS OF LOCAL BUILDING CODES. THEREFORE, YOUR LOCAL BUILDING CODES **MUST** BE CHECKED TO DETERMINE THE REQUIREMENTS FOR THESE STEPS.*

Factory-built fireplace chases should be constructed in the manner of all outside walls of the home to prevent cold air drafting problems. The chase should not break the outside building envelope in any manner.

This means that the walls, ceiling, base plate and cantilever floor of the chase should be insulated. Vapor and air infiltration barriers should be installed in the chase as per regional codes for the rest of the home. Additionally, Heat-N-Glo recommends that the inside surfaces be sheetrocked and taped for maximum air tightness.

To further prevent drafts, the firestops should be caulked to seal gaps. Gas line holes and other openings should be caulked or stuffed with insulation. If the unit is being installed on a cement slab, we recommend that a layer of plywood be placed underneath to prevent conducting cold up into the room. Be sure to include spark arrestors for woodburning units if they are required.

**THE CHASE SHOULD BE CONSTRUCTED SO THAT ALL CLEARANCES TO THE FIREPLACE ARE MAINTAINED AS SPECIFIED WITHIN THIS INSTALLERS GUIDE.**

## Step 1 Locating the Fireplace

The diagram below shows space and clearance requirements for locating a fireplace within a room.

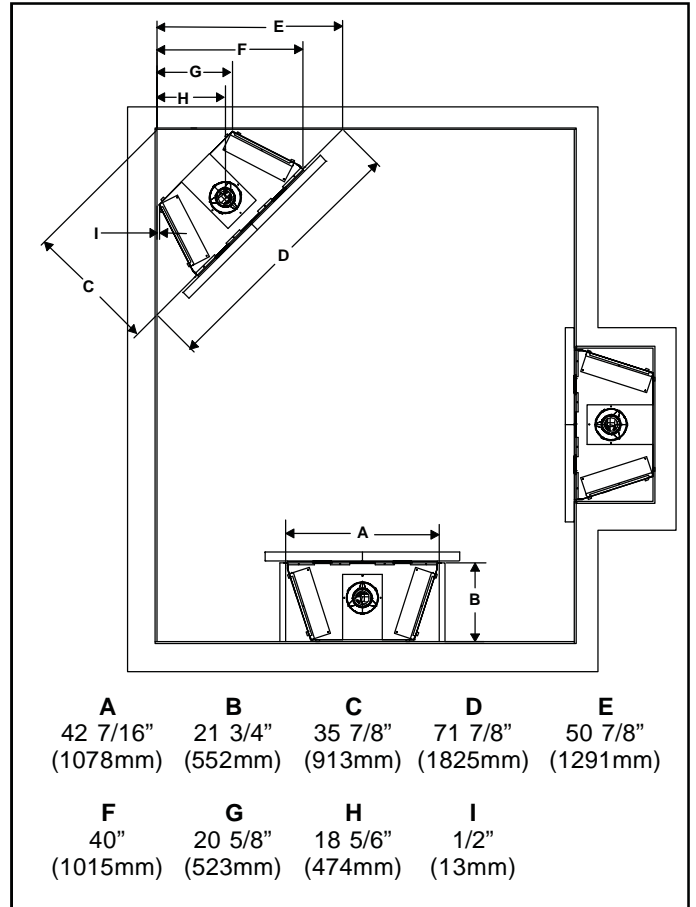

**Figure 2. Fireplace Dimensions, Locations, and Space Requirements for model CFX-Diamond**

### Clearance Requirements

The top, back, and sides of the fireplace are defined by stand-offs.

Minimum Clearances from the Fireplace to Combustible Materials					
Glass Front	Floor	Rear of Fireplace	Sides of Fireplace	Top of Fireplace	Ceiling
36 inches (914 mm)	5 9/16" (141 mm)	1/2 inch (13 mm)	1/2 inch (13 mm)	3-1/2 inches (89 mm)	31 inches (787 mm)

The minimum clearance to a perpendicular wall extending past the face of the fireplace is 4-inches (102 mm).

The back of the fireplace may be recessed 21 3/4 inches (552 mm) into combustible construction.



Minimum Clearances from the Vent Pipe to Combustible Materials						
For Horizontal Sections			For Vertical Sections	At Wall Firestops		
Top	Bottom	Sides	1 inch (25 mm)	Top	Bottom	Sides
3 inches* (75 mm)	1 inch (25 mm)	1 inch (25 mm)			2-1/2 inches (63.7 mm)	1/2 inch (13 mm)

For minimum clearances, see the direct vent termination clearance diagrams on pages 25 and 27 in this section.

\*Additional clearance and/or installation of a heat shield is required above the first 90° elbow. See page 19 of the Installers Guide.

## Step 2 Framing the Fireplace

Fireplace framing can be built before or after the fireplace is set in place. Framing should be positioned to accommodate wall coverings and fireplace facing material. The diagram below shows framing reference dimensions.

### CAUTION

**MEASURE FIREPLACE DIMENSIONS, AND VERIFY FRAMING METHODS AND WALL COVERING DETAILS BEFORE FRAMING CONSTRUCTION BEGINS.**

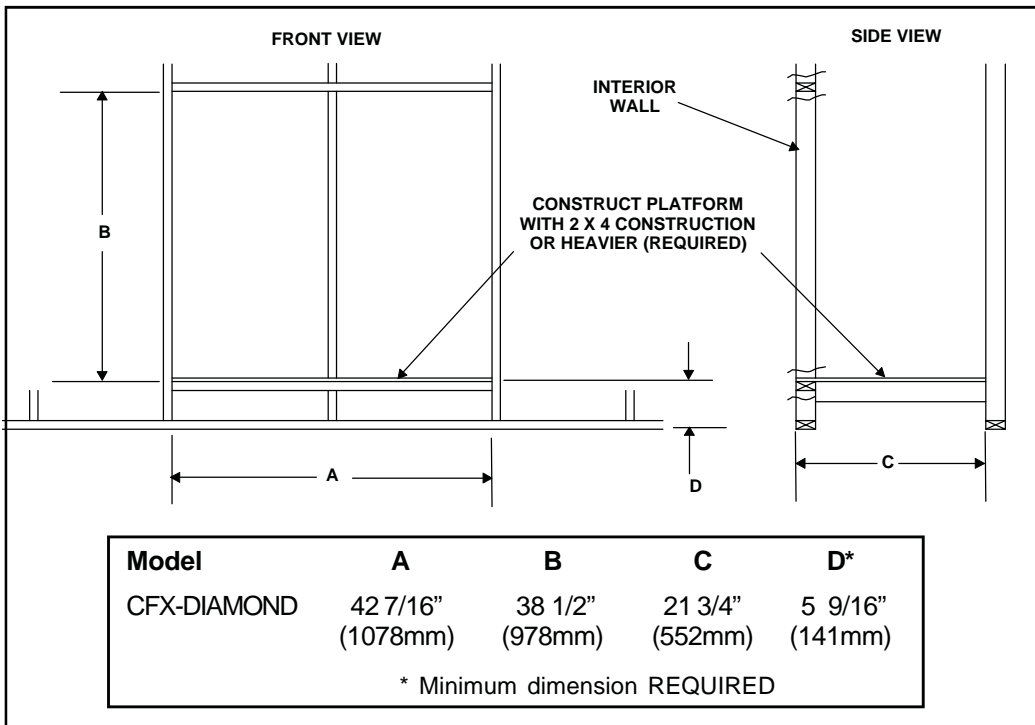

Figure 3. Framing Dimensions



**WARNING: THE CFX-DIAMOND REQUIRES AN ELEVATED PLATFORM CONSTRUCTION TO ACCOMMODATE THE DIAMOND SHAPED SURROUND WHICH IS LARGER THAN THE FIREPLACE (SEE FIGURE 1)**

### Step 3 Installing the Vent System

#### A. Vent System Approvals

This model is approved to use D-Series components and terminations. Approved vent system components are labeled for identification. **NO OTHER VENTING SYSTEM OR COMPONENTS MAY BE USED.** Detailed installation instructions are included with each vent termination kit and should be used in conjunction with this *Installers Guide*. The drawing below shows vent system components and terminations.

The flame and ember appearance may vary based on the type of fuel burned and the venting configuration used.

#### Identifying Vent Components

The vent systems installed on this gas fireplace may include one, two, or three 90° elbow assemblies. The relationships of vertical rise to horizontal run in vent configurations using 90° elbows **MUST BE** strictly adhered to. The rise to run relationship are shown in the venting drawings and tables. Refer to the diagrams on the next several pages.

**NOTE: TWO 45° ELBOWS MAY BE USED IN PLACE OF ONE 90° ELBOW. RISE TO RUN RATIOS IN THE VENT SYSTEM MUST BE FOLLOWED IF 45° ELBOWS ARE USED.**

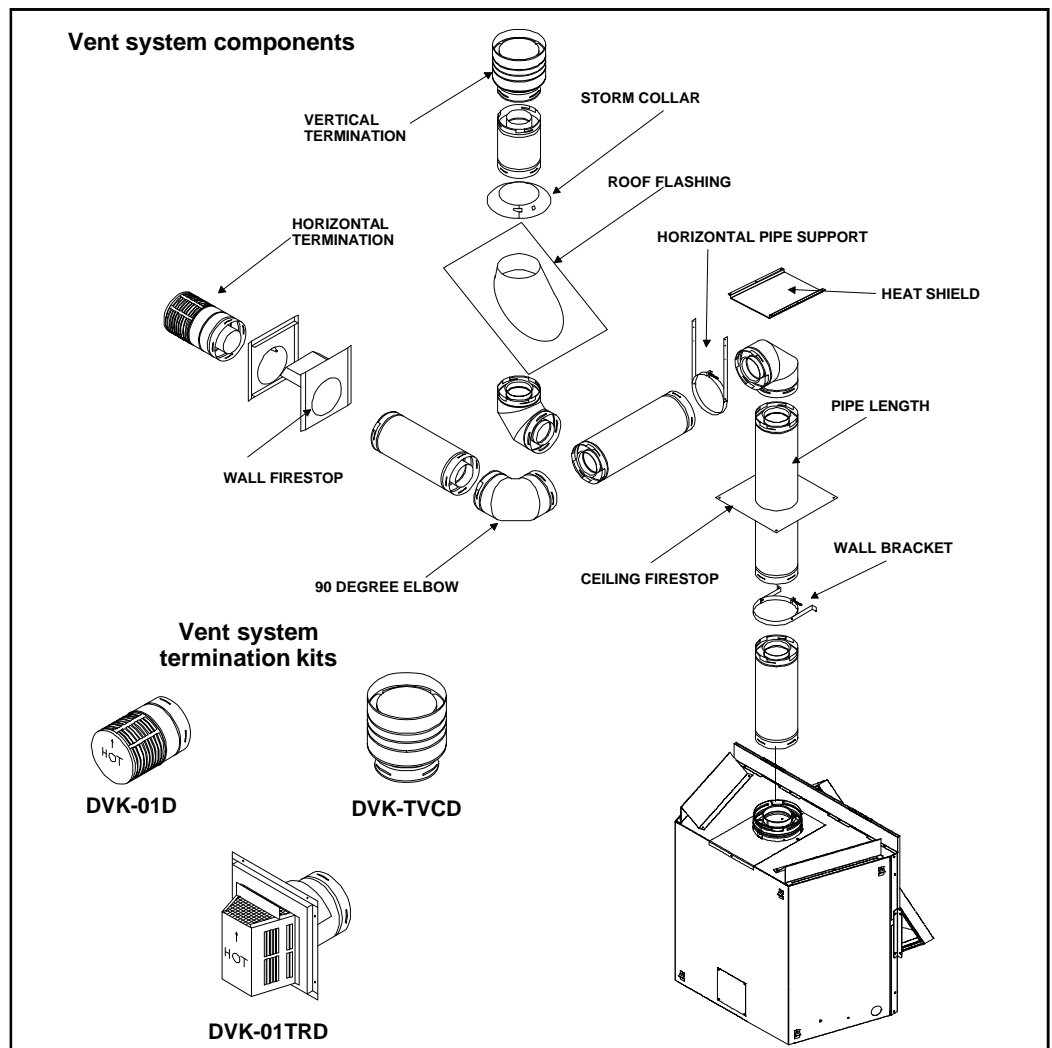
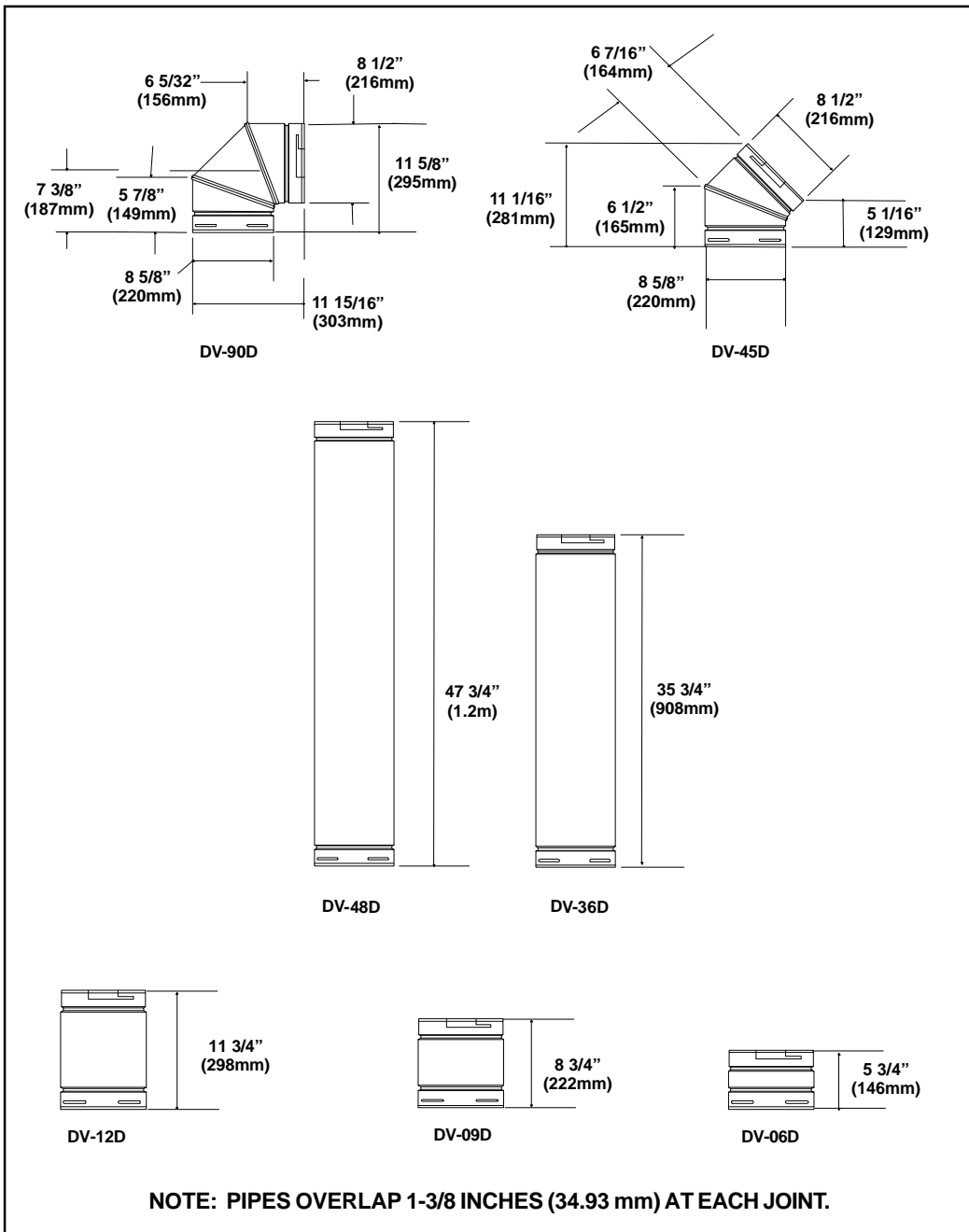
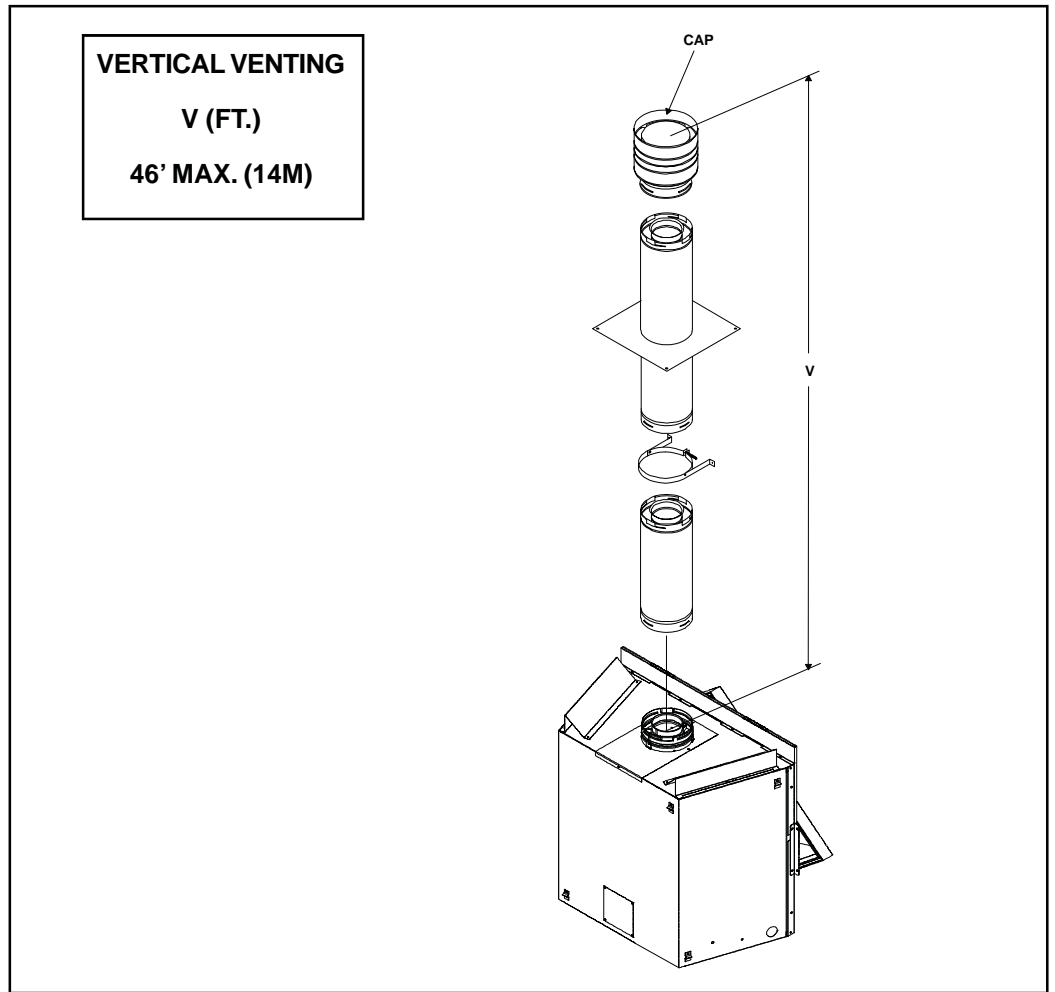

Figure 4. Vent Components and Terminations



**Figure 5. D-Series Direct Vent Component Specifications  
(5-inch inner pipe / 8 5/8-inch outer pipe)**



**Figure 6. Vertical Venting**

For vertical venting greater than  $V=12$  ft. (without any elbows installed), SRV593-170 vertical baffle kit may be installed for improved performance. Follow instructions provided with the kit.

### VENTING WITH ONE (1) 90° ELBOWS

V (FT.)	H (FT.)
0'	3' MAX. (.91m)
3' MIN. (914 mm)	9' MAX. (2.7m)
4' MIN. (1.2m)	12' MAX. (3.7m)
5' MIN. (1.6m)	15' MAX. (4.6m)
6' MIN. (1.9m)	18' MAX. (5.5m)

V + H = 30' MAX. (9.3 m)  
 Ratio V to H = 1:3      H = 20' MAX. (6.2m)

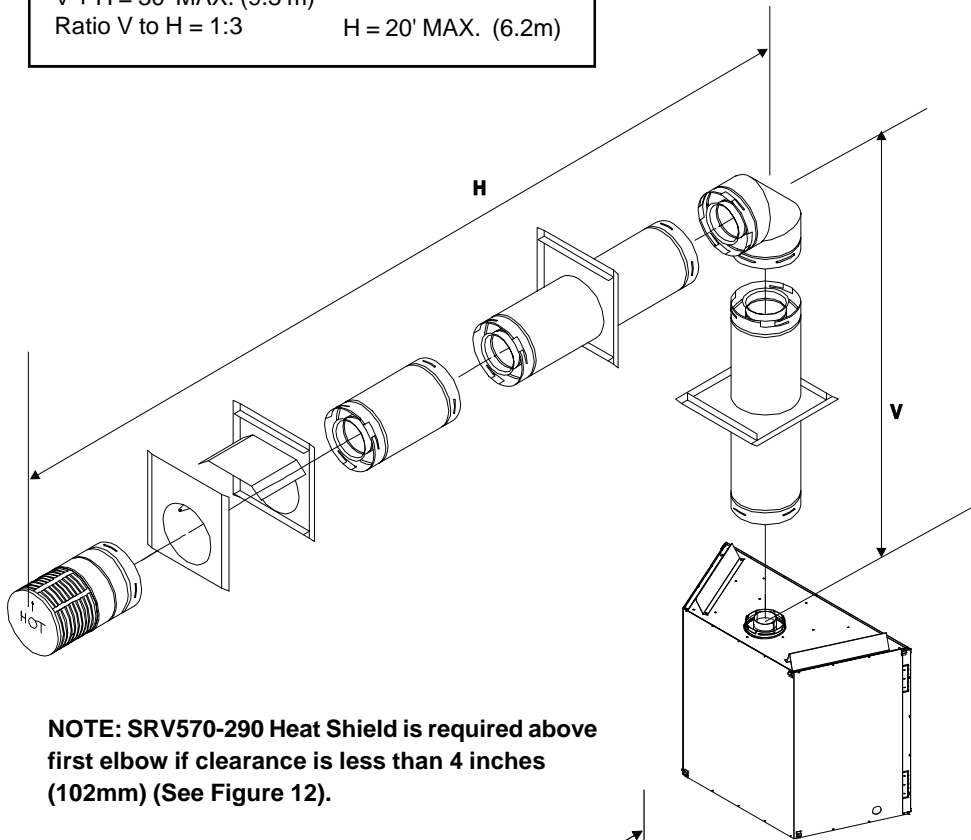

**NOTE: SRV570-290 Heat Shield is required above first elbow if clearance is less than 4 inches (102mm) (See Figure 12).**

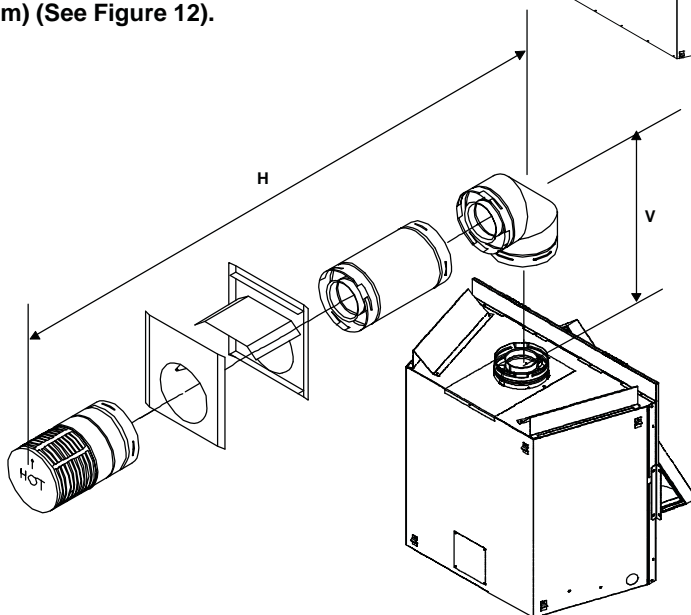

Figure 7. Venting with One 90° Elbow

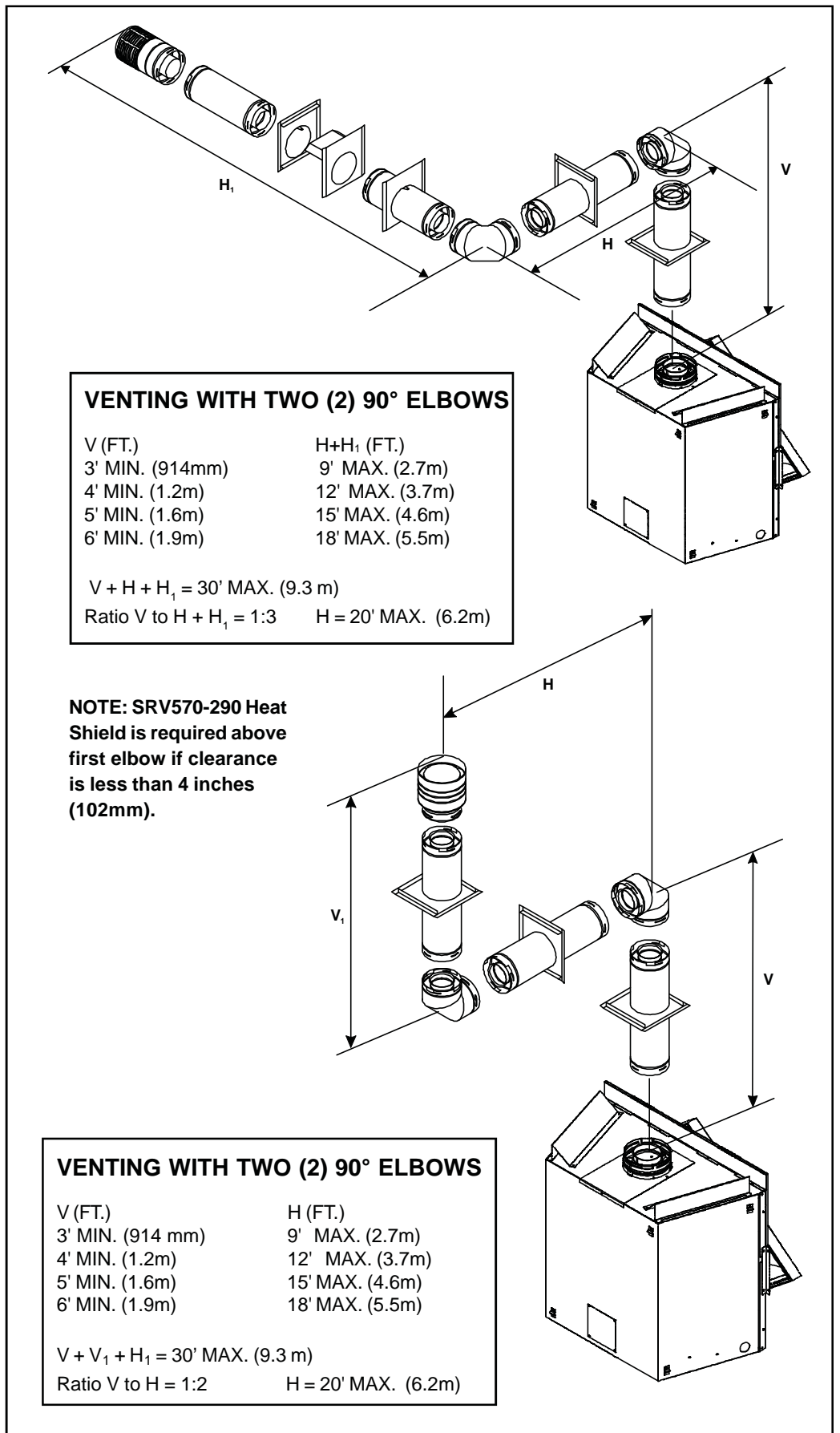

Figure 8. Venting with two 90° elbows

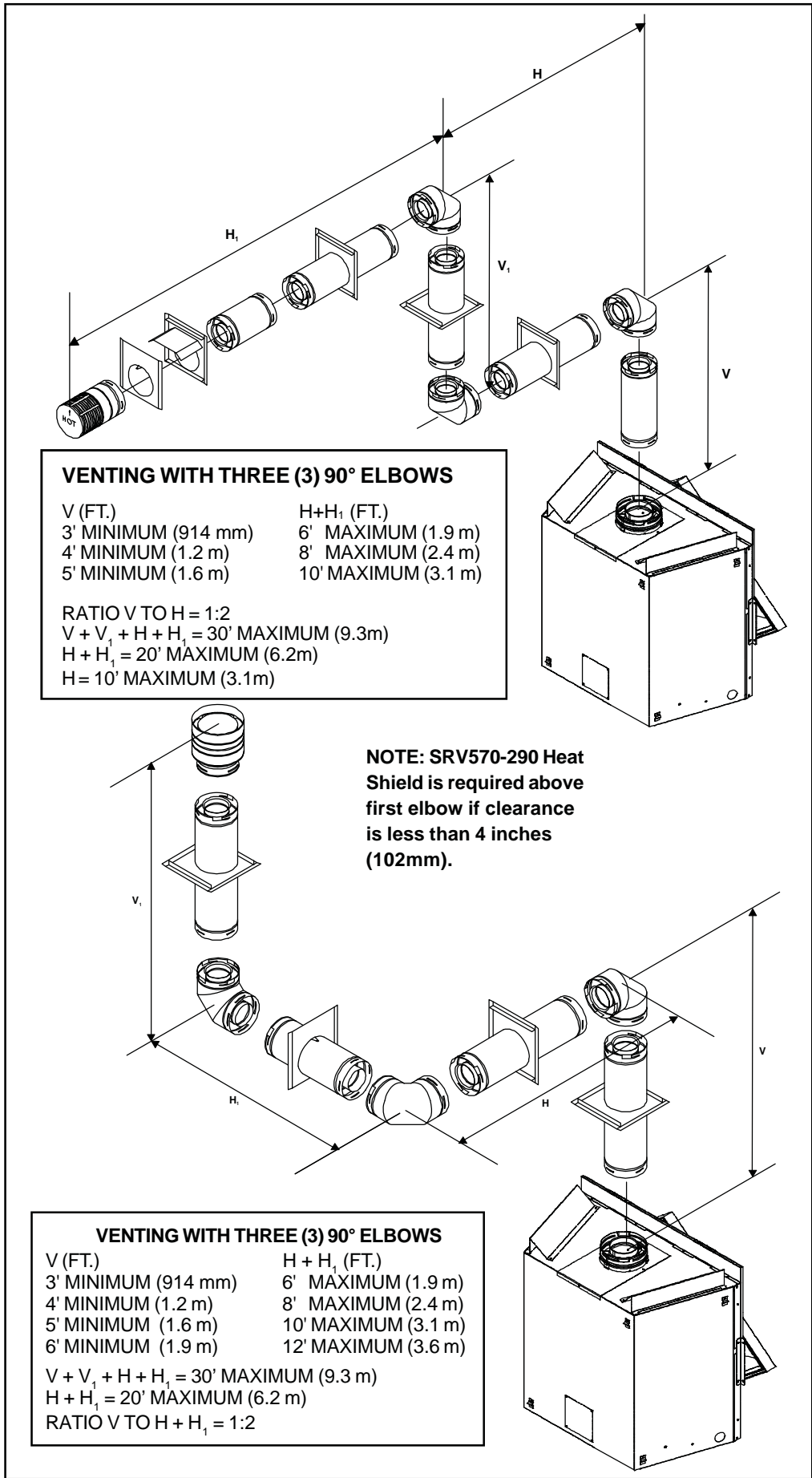

Figure 9. Venting with three 90° elbows

## B. Installing Vent Components

### 1. Attach the First Vent Component to the Starting Collars

- Apply a 3/8 inch (9.5 mm) bead of stove cement around the inner pipe fireplace starting collar.
- Make sure that the fireplace rope gasket supplied with the fireplace seals between the first 8-5/8 inch (219mm) vent component and the fireplace top.
- Lock the vent components into place by sliding the concentric pipe sections with four (4) equally spaced interior beads into the fireplace collar or previously installed component end with four (4) equally spaced indented sections.
- When the internal beads of each outer pipe line up, rotate the pipe section clockwise about one-quarter (1/4) turn. The vent pipe is now locked together.

1. Apply the stove cement.
2. Line up the internal beads and rotate the pipe sections clockwise until locked.
3. Lock the vent components into place.
4. Check the seal on the rope gasket.

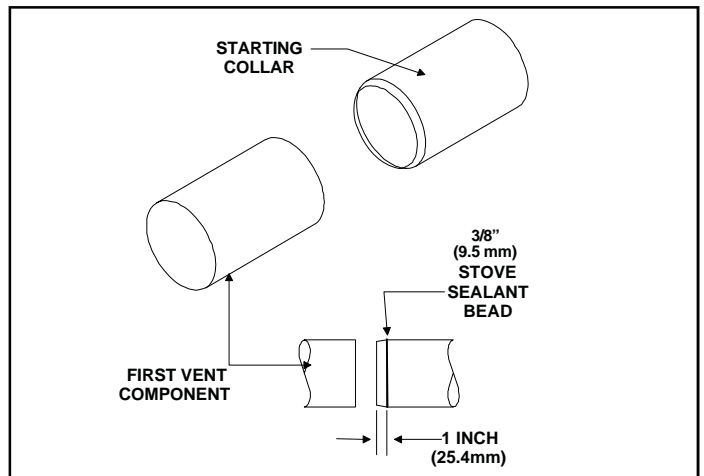

**Figure 10. Attaching the First Vent Component to the Starting Collars**

**! WARNING: A 3/8 INCH (9.5 MM) BEAD OF STOVE CEMENT MUST BE PLACED AROUND THE INNER PIPE FIREPLACE STARTING COLLAR BEFORE ATTACHING THE FIRST VENT COMPONENT. FAILURE TO SEAL THIS JOINT MAY CAUSE THE FIREPLACE TO OPERATE IMPROPERLY. SEE FIGURE 10.**

**! WARNING: ENSURE THAT THE FIBERGLASS ROPE GASKET SUPPLIED WITH THE FIREPLACE SEALS BETWEEN THE FIRST VENT COMPONENT AND THE FIREPLACE TOP.**



## 2. Continue Adding Vent Components

To continue adding vent components in accordance with the pre-planned vent system configuration:

- Ensure that each succeeding vent component is securely fitted and locked into the preceding component in the vent system.

Continue adding vent components, locking each succeeding component into place.

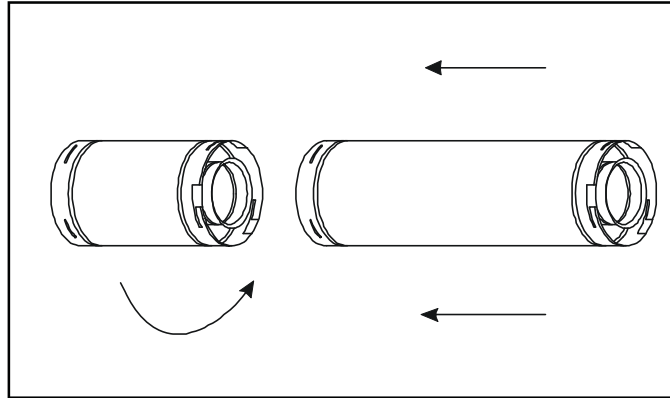
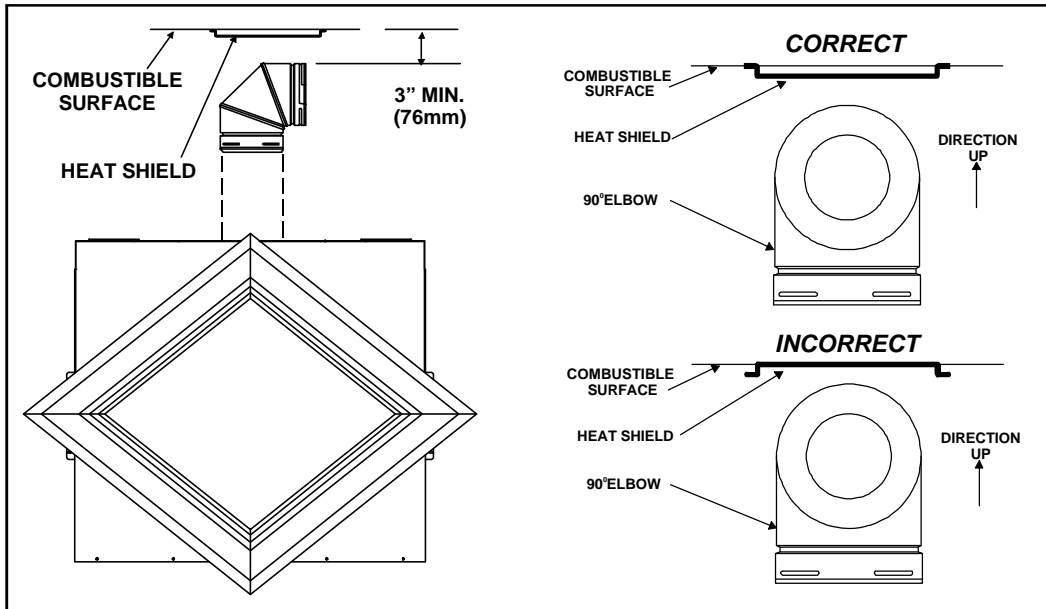

**Figure 11. Adding Venting Components**

90° elbows may be installed and rotated to any point around the preceding component's vertical axis. If an elbow does not end up in a locked position with the preceding component, attach with a minimum of two (2) sheet metal screws.



**WARNING: MODEL CFX-DIAMOND  
REQUIRES SHIELD SRV570-290 ABOVE  
THE FIRST 90° ELBOW IN THE SYSTEM  
IF CLEARANCE IS LESS THAN 4 INCHES  
(102MM). SEE INSTALLATION SHEET AND  
HEAT SHIELD SUPPLIED WITH FIREPLACE.**



**Figure 12. Placement of SRV570-290 Heat Shield  
First 90° elbow in system.**

### 3. Install Support Brackets

**For Horizontal Runs** - The vent system must be supported every five (5) feet of horizontal run by a horizontal pipe support.

To install support brackets for horizontal runs:

- Place the pipe supports around the vent pipe.
- Nail the pipe supports to the framing members.

#### **For Vertical Runs** -

The vent system must be supported every eight (8) feet (2.4 m) above the fireplace flue outlet by wall brackets.

To install support brackets for vertical runs:

- Attach wall brackets to the vent pipe and secure the wall bracket to the framing members with nails or screws.

Use wall brackets to support vertical runs every 8 feet (2.4 m) above the fireplace flue outlet.

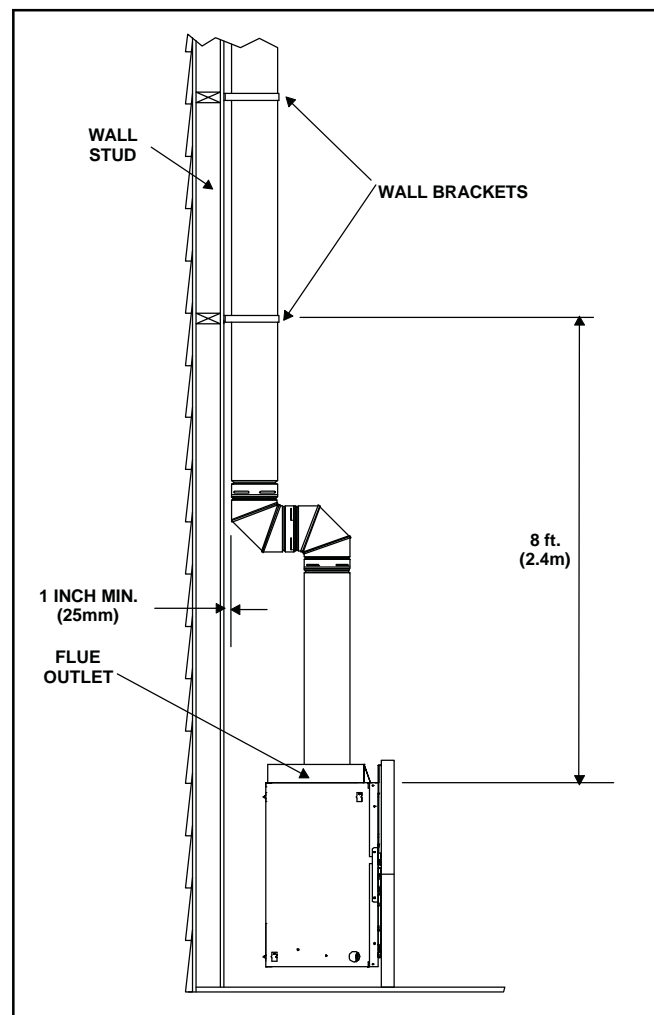

Figure 13. Installing Support Brackets

### 4. Install Firestops

**For Horizontal Runs** - Firestops are **REQUIRED** on both sides of a combustible wall through which the vent passes.

*Model DVK-01TRD does not need an exterior firestop on an exterior combustible wall.*

To install firestops for horizontal runs that pass through either interior or exterior walls:

- Cut a 12-inch by 12-inch (305mm X 305mm) hole through the wall. The center of the hole is one (1) inch (25.4 mm) above the center of the horizontal vent pipe.

#### **NOTE**

- Position the firestops on both sides of the hole previously cut and secure the firestops with nails or screws.
- The heat shields of the firestops **MUST BE** placed towards the top of the hole.
- Continue the vent run through the firestops.

**NOTE: There must be NO INSULATION or other combustibles inside the framed firestop opening.**

1. Cut the hole through the wall.

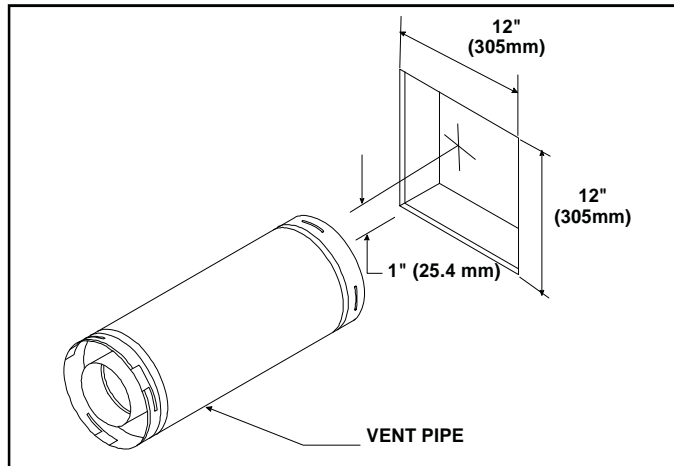

**Figure 14. Hole and Vent Pipe**

2. Position the firestops.
3. Place the heat shield to the top.
4. Continue the vent run.

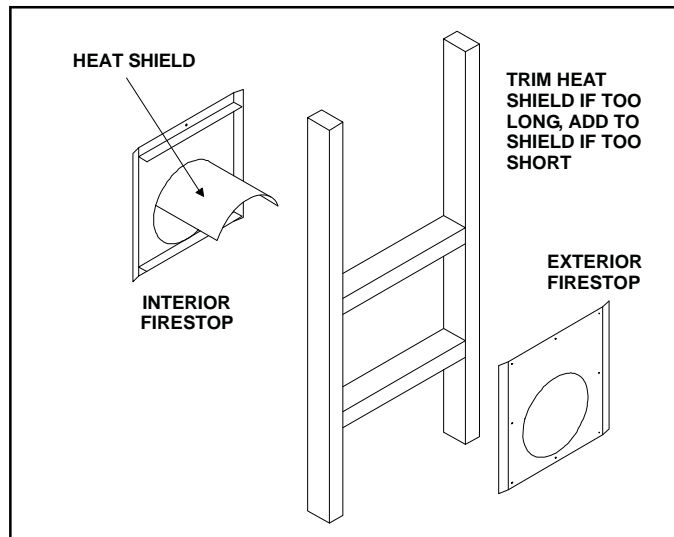

**Figure 15. Heat Shield, Interior & Exterior Firestops**

**For Vertical Runs - One ceiling firestop is REQUIRED** at the hole in each ceiling through which the vent passes.

To install firestops for vertical runs that pass through ceilings:

- Position a plumb bob directly over the center of the vertical vent component.
- Mark the ceiling to establish the centerpoint of the vent.

- Drill a hole or drive a nail through this centerpoint.
- Check the floor above for any obstructions, such as wiring or plumbing runs.
- Reposition the fireplace and vent system, if necessary, to accommodate the ceiling joists and/or obstructions.
- Cut a 11-inch X 11-inch (280 mm X 280 mm) hole through the ceiling, using the centerpoint previously marked.
- Frame the hole with framing lumber the same size as the ceiling joists.

1. Cut the ceiling hole.
2. Add the new framing members.

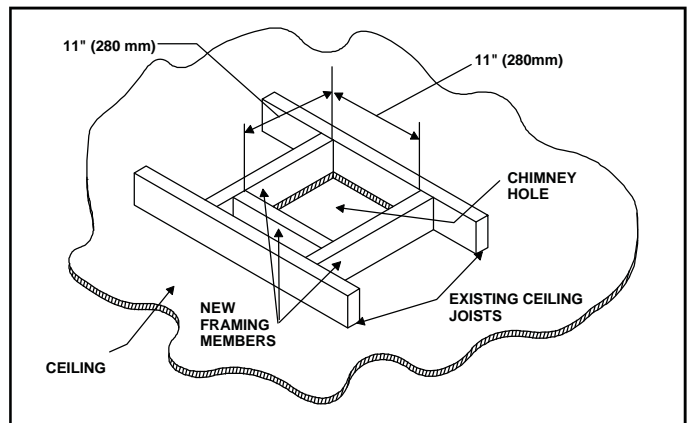
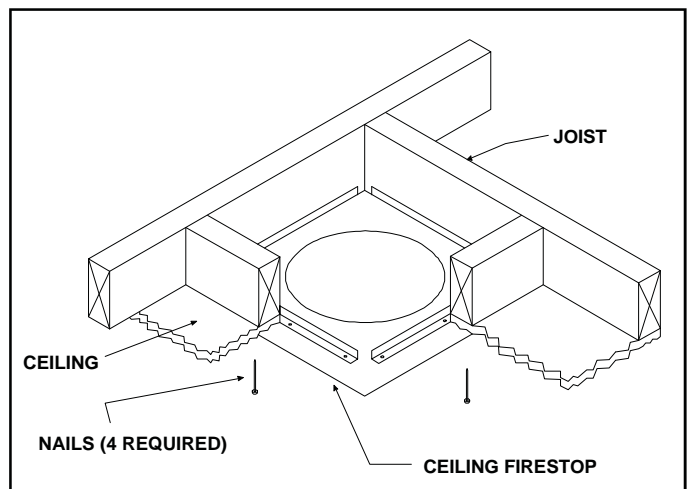

**Figure 16. Hole and New Framing Members**

If the area above the ceiling is **NOT** an attic, position and secure the ceiling firestop on the ceiling side of the previously cut and framed hole.

**NOTE: There must be NO INSULATION or other combustibles inside the framed firestop opening.**

This shows a ceiling installation.

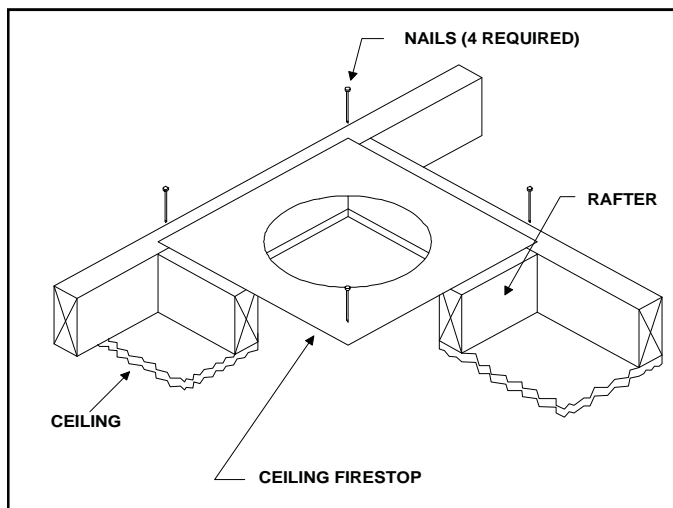

**Figure 17. Ceiling Firestop (Ceiling Side)**

If the area above the ceiling **IS** an attic, position and secure the firestop on top of the previously framed hole.

This shows an attic installation.

1. Keep insulation away from the vent pipe at least 1 inch (25 mm).



**Figure 18. Attic Firestop**

### C. Vent Termination

**For Horizontal Terminations** - To attach and secure the termination to the last section of horizontal vent:

- Rotate and interlock the ends as described at the beginning of the Installing Vent Components section.
- The termination kit should pass through the wall firestops from the exterior of the building.
- Adjust the termination cap to its final exterior position on the building.



**WARNING**  
**THE TERMINATION CAP MUST BE POSITIONED SO THAT THE ARROW IS POINTING UP.**

For roundcap termination kits:

- Use the exterior pipelock hole provided on the round flange of the wall firestop to secure the vent pipe in place.

For trapezoidal cap termination kits:

- Using screws, secure the cap to the exterior wall through the flanges built into the cap.

For round cap termination:

1. Secure the pipe, using the exterior pipelock hole on the round flange of the wall firestop.

For trapezoidal termination:

1. Screw the cap to the exterior wall through the flanges in the cap.

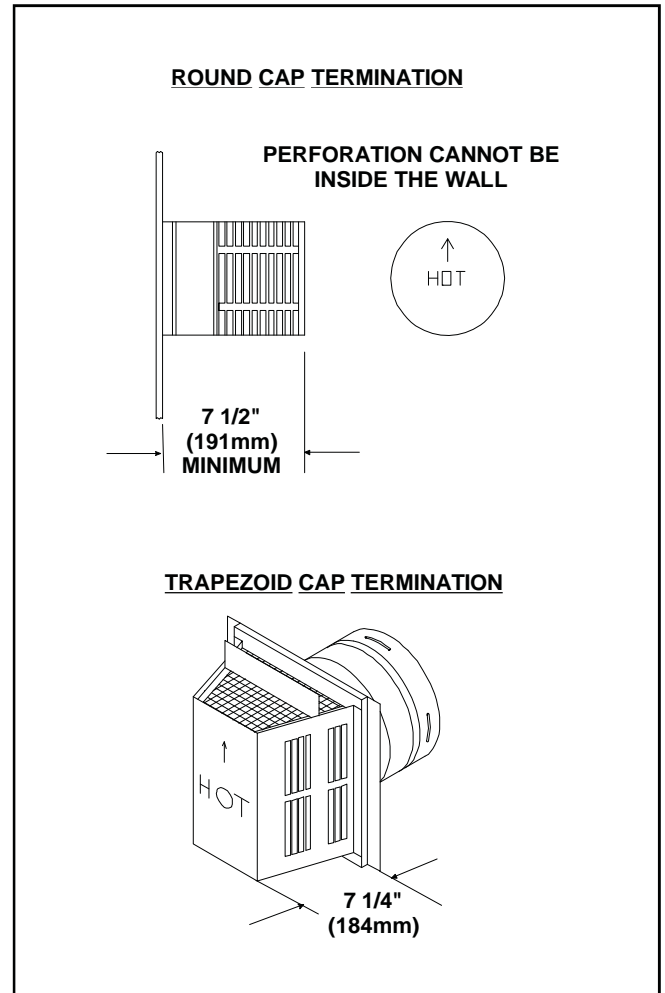
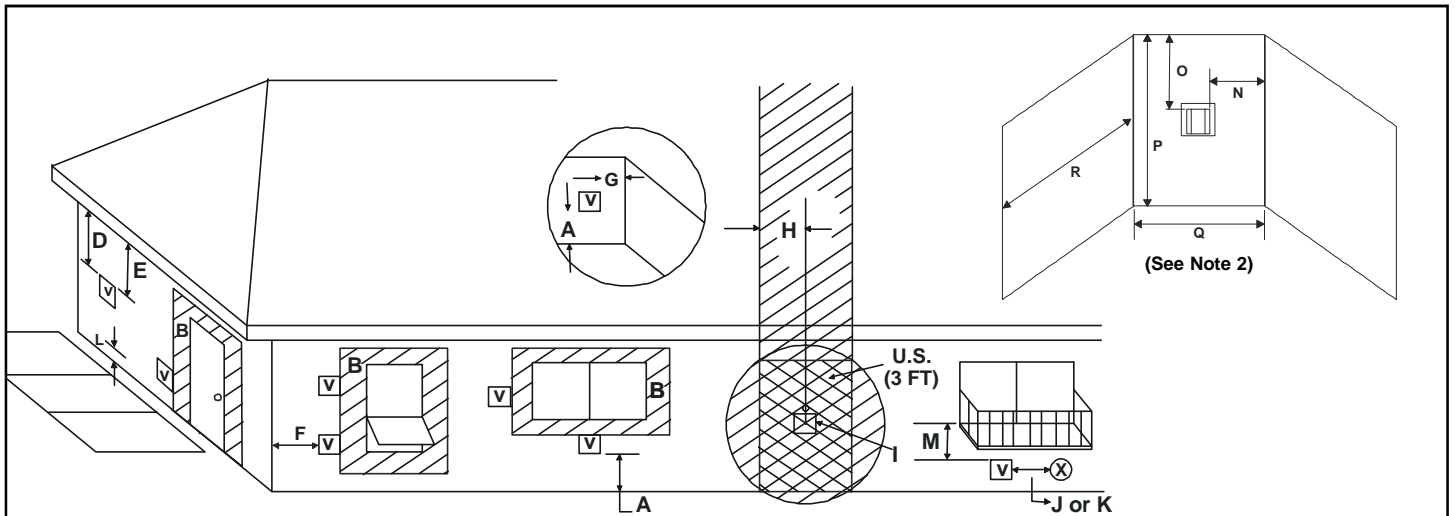

Figure 19. Round & Trapezoid Termination Caps



**WARNING**

THE BOTTOM OF THE VENT TERMINATION CAP MUST BE A MINIMUM OF 12 INCHES (305MM) ABOVE GROUND LEVEL (GRADE). THE TOP OF THE CAP MUST BE A MINIMUM OF 36 INCHES (914 MM) BELOW COMBUSTIBLE MATERIAL, SUCH AS A DECK, AND THE SIDE OF THE CAP MUST BE A MINIMUM OF 6 INCHES (152 MM) AWAY FROM A PARALLEL OUTSIDE WALL. VENTING TERMINALS SHALL NOT BE RECESSED INTO A WALL OR SIDING. SEE THE FOLLOWING DIAGRAM FOR VENT TERMINATION



**V** = VENT TERMINAL      **X** = AIR SUPPLY INLET      = AREA WHERE TERMINAL IS NOT PERMITTED

<p><b>A</b> = 12" ..... clearances above grade, veranda, porch, deck or balcony (See Note 1)</p> <p><b>B</b> = 12" ..... clearances to window or door that may be opened, or to permanently closed window.</p> <p><b>D*</b> = 36" ..... vertical clearance to ventilated soffit located above the terminal within a horizontal distance of 2 feet (60 cm) from the center-line of the terminal</p> <p><b>E*</b> = 36" ..... clearance to unventilated soffit</p> <p><b>F</b> = 9" ..... clearance to outside corner</p> <p><b>G</b> = 6" ..... clearance to inside corner</p> <p><b>H</b> = 3 ft. (Canada) ..... not to be installed above a gas meter/regulator assembly within 3 feet (90cm) horizontally from the center-line of the regulator</p> <p><b>I</b> = 3 ft. (U.S.A.) 6 ft. (Canada) ..... clearance to service regulator vent outlet and electric service</p>	<p><b>J</b> = 9" (U.S.A.) 12" (Canada) ..... clearance to non-mechanical air supply inlet to building or the combustion air inlet to any other appliance</p> <p><b>K</b> = 3 ft. (U.S.A.) 6 ft. (Canada) ..... clearance to a mechanical air supply inlet</p> <p><b>L**</b> = 7 ft. .... clearance above paved sidewalk or a paved driveway located on <b>public</b> property (See Note 1)</p> <p><b>M***</b> = 36" ..... clearance under veranda, porch, deck or balcony</p> <p><b>N</b> = 6" ..... non-vinyl soffit and siding 12" ..... vinyl soffit and siding</p> <p><b>O</b> = 18" ..... non-vinyl soffit and siding 42" ..... vinyl soffit and siding</p> <p><b>P</b> = 8 ft.</p>
---	--

	<b>Q<sub>MIN</sub></b>	<b>R<sub>MAX</sub></b>
1 cap	3 feet	2 x Q <sub>ACTUAL</sub>
2 caps	6 feet	1 x Q <sub>ACTUAL</sub>
3 caps	9 feet	2/3 x Q <sub>ACTUAL</sub>
4 caps	12 feet	1/2 x Q <sub>ACTUAL</sub>
<b>Q<sub>MIN</sub></b> = # termination caps x 3 <b>R<sub>MAX</sub></b> = (2 / # termination caps) x Q <sub>ACTUAL</sub>		

\* 5 foot minimum for vinyl clad soffits.

\*\* a vent shall not terminate directly above a sidewalk or paved driveway which is located between two single family dwellings and serves both dwellings.

\*\*\* only permitted if veranda, porch, deck or balcony is fully open on a minimum of 2 sides beneath the floor.

**NOTE 1:** On private property where termination is less than 7 feet above a sidewalk, driveway, deck, porch, veranda or balcony, use of a listed cap shield is suggested.

**NOTE 2:** Termination in an alcove space (spaces open only on one side and with an overhang) are permitted with the dimensions specified for vinyl or non-vinyl siding and soffits. **1.** There must be 3 feet minimum between termination caps. **2.** All mechanical air intakes within 10 feet of a termination cap must be a minimum of 3 feet below the termination cap. **3.** All gravity air intakes within 3 feet of a termination cap must be a minimum of 1 foot below the termination cap.

**NOTE 3:** Local codes or regulations may require different clearances.

**NOTE 4:** Termination caps may be hot. Consider their proximity to doors or other traffic areas.

**WARNING: In the U.S:** Vent system termination is **NOT** permitted in screened porches. You must follow side wall, overhang and ground clearances as stated in the instructions.

**In Canada:** Vent system termination is **NOT** permitted in screened porches. Vent system termination is permitted in porch areas with two or more sides open. You must follow all side walls, overhang and ground clearances as stated in the instructions.

Heat-N-Glo assumes no responsibility for the improper performance of the fireplace when the venting system does not meet these requirements.

**Figure 20. Vent Termination Minimum Clearances**

**CAUTION: IF EXTERIOR WALLS ARE FINISHED WITH VINYL SIDING, IT IS NECESSARY TO INSTALL THE VINYL PROTECTOR KIT TO THE TOP OF THE EXTERIOR FIRESTOP (FOR ALL ROUND TERMINATION CAPS). IT IS STRONGLY RECOMMENDED WHENEVER POSSIBLE TO USE THE VINYL PROTECTOR KIT.**

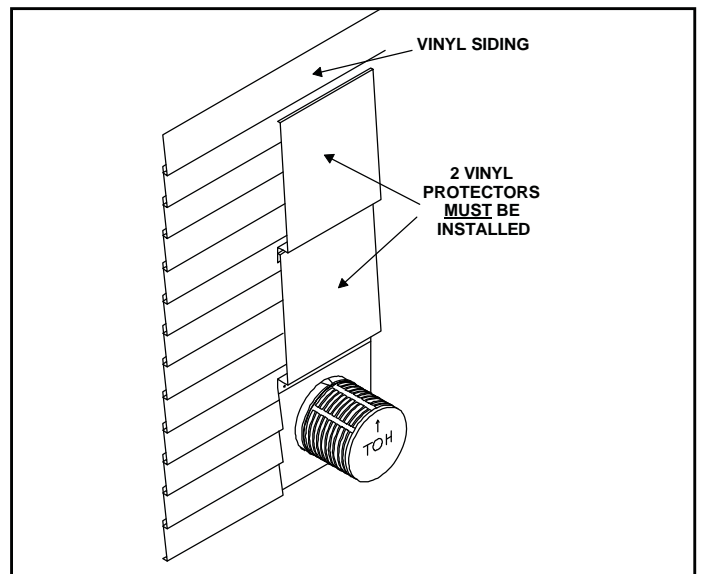

**Figure 21. Two Vinyl Protectors**

**For Vertical Terminations** - To locate the vent and install the vent sections:

- Locate and mark the vent centerpoint on the underside of the roof, and drive a nail through the centerpoint.
- Make the outline of the roof hole around the centerpoint nail.
- The size of the roof hole framing dimensions depend on the pitch of the roof. There **MUST BE** a 1-inch (25.4mm) clearance from the vertical vent pipe to combustible materials.
- Mark the roof hole accordingly.
- Cover the opening of the installed vent pipes.
- Cut and frame the roof hole.
- Use framing lumber the same size as the roof rafters and install the frame securely. Flashing anchored to the frame must withstand heavy winds.
- Continue to install concentric vent sections up through the roof hole (for inside vent installations) or up past the roof line until you reach the appropriate distance above the roof (for outside terminations).



**WARNING: MAJOR U.S. BUILDING CODES SPECIFY MINIMUM CHIMNEY AND/OR VENT HEIGHT ABOVE THE ROOF TOP. THESE MINIMUM HEIGHTS ARE NECESSARY IN THE INTEREST OF SAFETY. SEE THE FOLLOWING DIAGRAM FOR MINIMUM HEIGHTS, PROVIDED THE TERMINATION CAP IS AT LEAST TWO (2) FEET FROM A VERTICAL WALL AND 2-FEET BELOW A HORIZONTAL OVERHANG.**

**NOTE**

*This also pertains to vertical vent systems installed on the outside of the building.*



To seal the roof hole, and to divert rain and snow from the vent system:

- Attach a flashing to the roof using nails, and use a non-hardening mastic around the edges of the flashing base where it meets the roof.
- Attach a storm collar over the flashing joint to form a water-tight seal. Place non-hardening mastic around the joint, between the storm collar and the vertical pipe.
- Slide the termination cap over the end of the vent pipe and rotate the pipe clockwise 1/4 turn.

1. Attach the flashing and apply sealant around the edges of the flashing base.
2. Attach the storm collar over the flashing joint and apply sealant between the storm collar and vertical pipe.

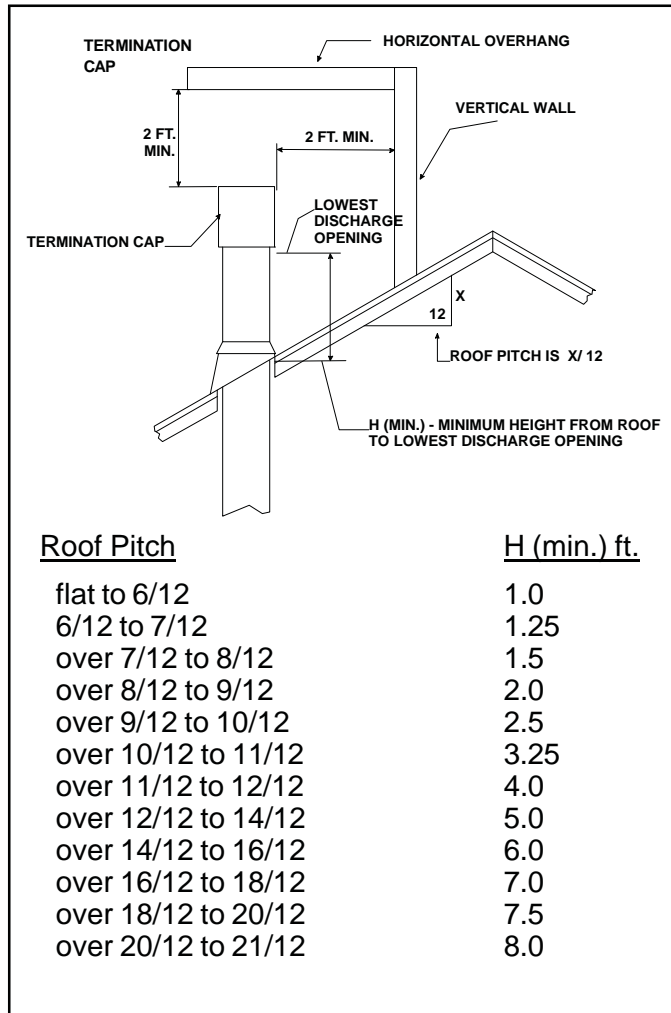
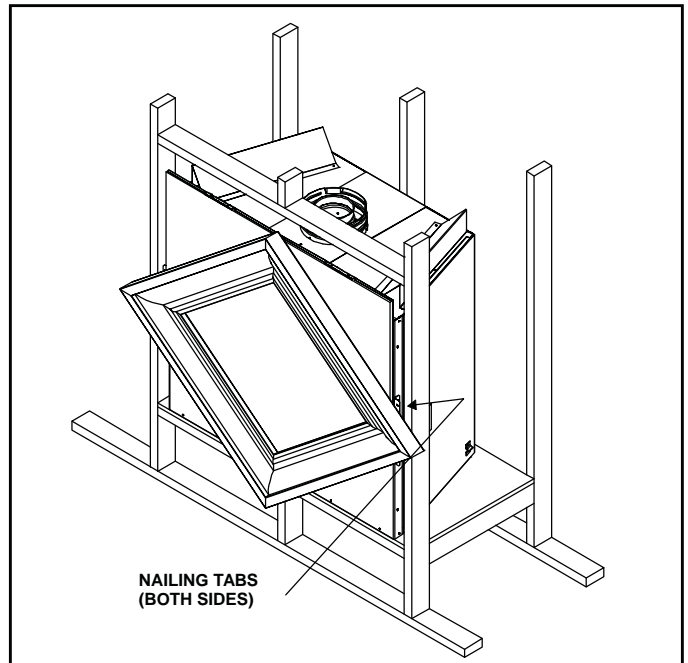

**Figure 22. Minimum Height from Roof to Lowest Discharge Opening**

## Step 4 Positioning, Leveling, and Securing the Fireplace

1. Place the fireplace into position.
2. Level the fireplace from side to side and from front to back.
3. Shim the fireplace with non-combustible material, such as sheet metal, as necessary.
4. Secure the fireplace to the framing by nailing or screwing

The diagram below shows how to properly position, level, and secure the fireplace.



**Figure 23. Proper Positioning, Leveling, and Securing of a Fireplace**

## Step 5 Gas Control System



**WARNING: THIS UNIT IS NOT FOR USE WITH SOLID FUEL.**

### **Intermittent Pilot Ignition (IPI) System**

The gas control system used with this model is *Intermittent Pilot Ignition (IPI)*. This system includes a 3V control valve, electronic module, and intermittent pilot.



**WARNING: CONTINUOUS 110-120 VAC SERVICE MUST BE WIRED TO THE FIREPLACE JUNCTION BOX.**

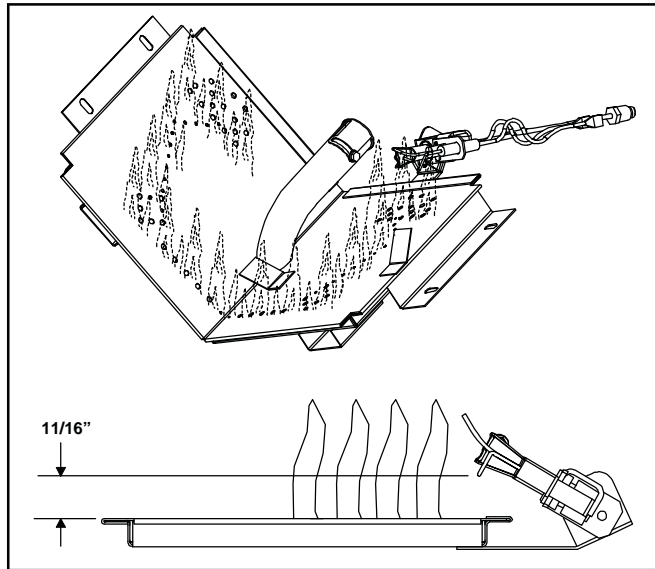

Figure 24. Gas Controls System

## Step 6 The Gas Supply Line

**NOTE:** Have the gas supply line installed in accordance with local building codes by a qualified installer approved and/or licensed as required by the locality. (In the state of Massachusetts installation must be performed by a licensed plumber or gas fitter).

**NOTES:** Before the first firing of the fireplace, the gas supply line should be purged of any trapped air.

**NOTE:** Consult local building codes to properly size the gas supply line leading to the 1/2 inch (13mm) hook-up at the unit.

This gas fireplace is designed to accept a 1/2 inch (13mm) gas supply line. To install the gas supply line:

- A listed (and State of Massachusetts approved) 1/2 inch (13mm) tee-handle manual shut-off valve and a listed flexible gas connector are connected to the 1/2 inch (13mm) inlet of the control valve. **NOTE:** If substituting for these components, please consult local codes for compliance.
- A 1/8 inch (3mm) N.P.T. plugged tapping, accessible for test gauge connection, should be provided for in the gas supply line leading to the unit's shut-off valve.
- Locate the gas line access hole in the outer casing of the fireplace.
- Insert the gas supply line through the gas line hole, and connect it to the shut-off valve.
- When attaching the pipe, support the control so that the lines are not bent or torn.
- After the gas line installation is complete, use a soap solution to carefully check all gas connections for leaks.



**WARNING: DO NOT USE AN OPEN FLAME TO CHECK FOR GAS LEAKS.**

- The gap between the supply piping and gas access hole can be plugged with non-combustible insulation to prevent cold air infiltration.
- Insert insulation from the outside of the fireplace and pack the insulation tightly to totally seal between the pipe and the outer casing.
- The gas line should be installed by a qualified service technician.

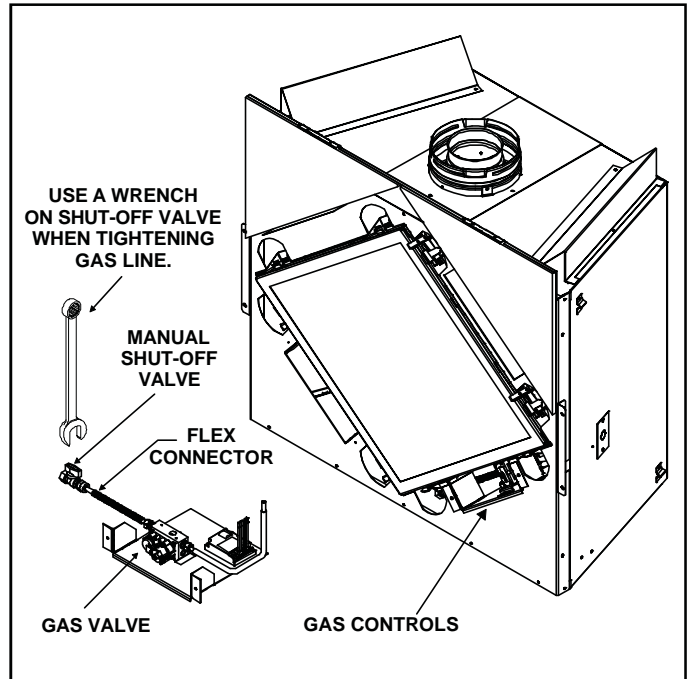

**Figure 25. Gas Supply Line**

Pressure requirements for these gas fireplaces are shown in the table below.

Pressure	Natural Gas	Propane
Minimum Inlet Pressure	7.0 inches w.c.	12.0 inches w.c.
Maximum Inlet Gas Pressure	14.0 inches w.c.	14.0 inches w.c.
Manifold Pressure	3.5 inches w.c.	10.0 inches w.c.

A one-eighth (1/8) inch (3 mm) N.P.T. plugged tapping is provided on the inlet and outlet side of the gas control for a test gauge connection to measure the manifold pressure.

The fireplace and its individual shut-off valve must be disconnected from the gas supply piping system during any pressure testing of the system at test pressures in excess of one-half (1/2) psig (3.5 kPa).

The fireplace must be isolated from the gas supply piping system by closing its individual shut-off valve during any pressure testing of the gas supply piping system at test pressures equal to or less than one-half (1/2) psig (3.5 kPa).

## Step 7 Gas Pressure Requirements

## Step 8 Wiring the Fireplace

**NOTE:** Electrical wiring must be installed by a licensed electrician.

***DISCONNECT REMOTE CONTROLS IF YOU ARE ABSENT FOR EXTENDED TIME PERIODS. THIS WILL PREVENT ACCIDENTAL FIREPLACE OPERATION.***

### Intermittent Pilot Ignition (IPI) Wiring

#### Appliance Requirements

This appliance requires that 110-120 VAC be wired to the factory installed junction box. Maintain correct polarity when wiring the junction box.

#### Battery Operation

This fireplace has an optional battery operation. The system is fully functional with the use of two "D" size batteries without ordinary 110-120 VAC power.

#### Installing the Batteries

Remove battery pack which is secured in place adjacent to gas control valve (secured with velcro strip). Orient two "D" size batteries per the diagram on battery pack. Re-install battery pack in the same location.

#### Operation using Battery Power

Wiring to the battery pack is left disconnected in order to conserve battery life. In the case of a loss of power, simply connect red and black wire leads to activate battery power (connect red to red, black to black). The fireplace can be used as necessary. Once power (110 VAC) is restored, disconnect red and black wire leads to extend battery life.

#### Optional Accessories

Remote control kits require that 110-120 VAC be wired to the fireplace junction box.

#### Wall Switch

Position the wall switch in the desired position on a wall. Run a maximum of 25 feet (7.8 m) or less of 16 A.W.G. minimum wire and connect it to the fireplace ON/OFF switch pigtails.

#### **NOTE**

*Electrical wiring must be installed by a licensed electrician.*

#### **CAUTION**

***LABEL ALL WIRES PRIOR TO DISCONNECTION WHEN SERVICING CONTROLS. WIRING ERRORS CAN CAUSE IMPROPER AND DANGEROUS OPERATION. VERIFY PROPER OPERATION AFTER SERVICING.***

#### **NOTE**

***See Figure 27 for electrical diagram. Disregard pages 17, 18 and 19 of User's Manual.***

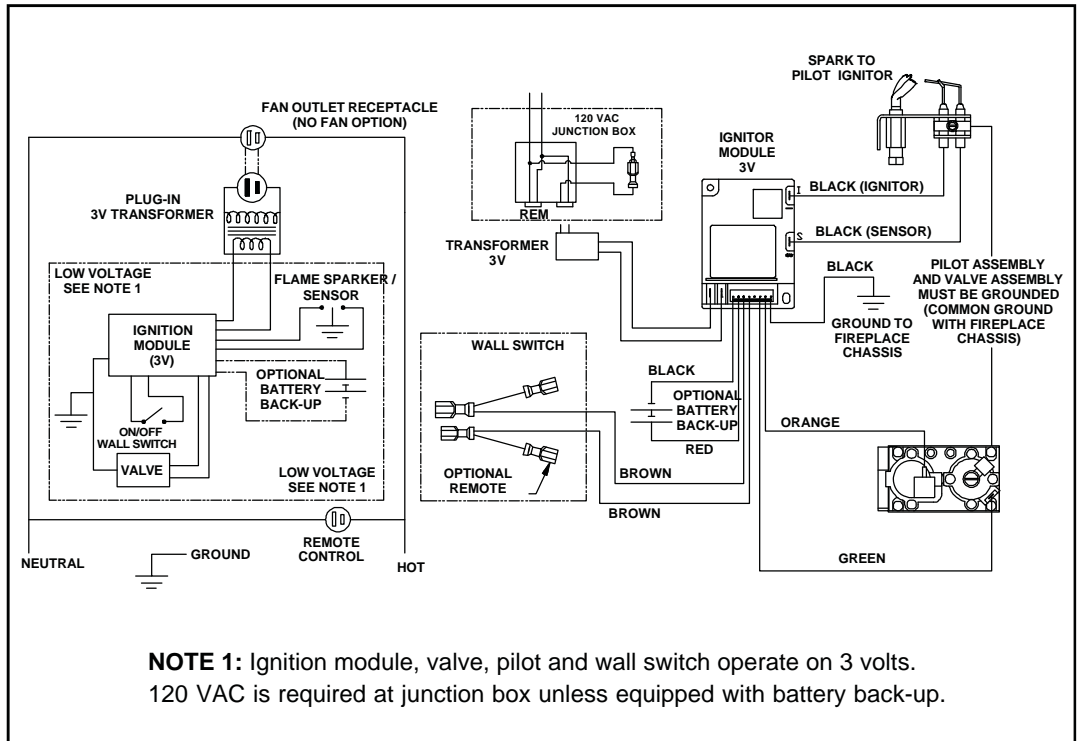
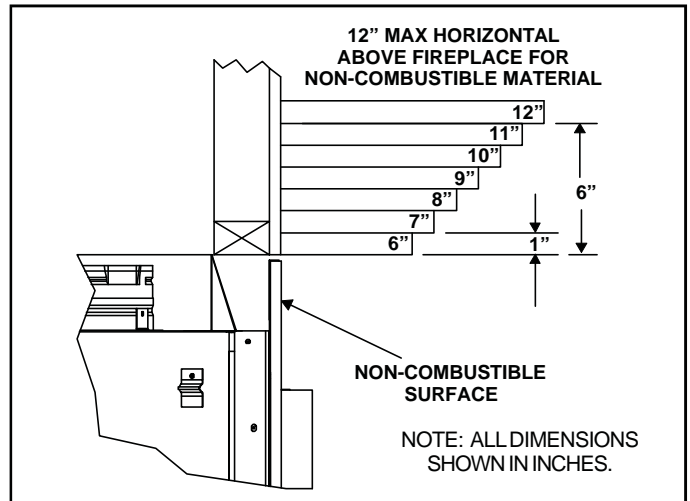

**Figure 27. Intermittent Pilot Ignition (IPI) Wiring Diagram**

## Step 9 Finishing

The following diagram shows the minimum vertical and corresponding maximum horizontal dimensions of fireplace mantels or other combustible projections above the top front edge of the fireplace. See Figures 2 and 3 for other fireplace clearances.

Only non-combustible materials may be used to cover the fireplace front above the glass.

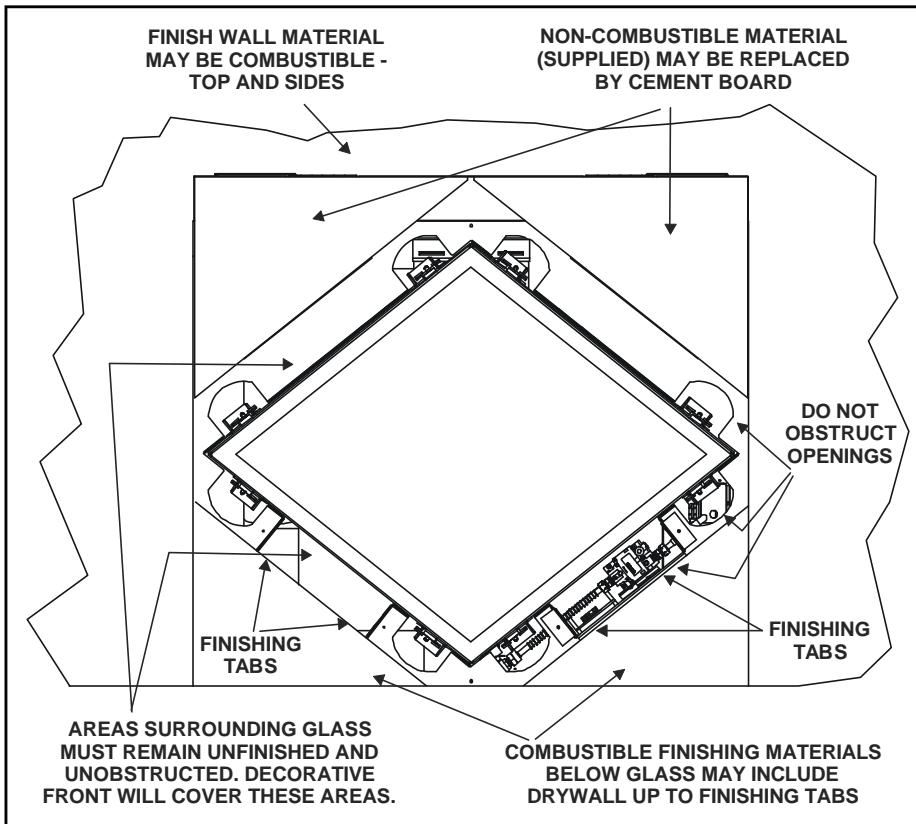

**Figure 28. Minimum Vertical and Maximum Horizontal Dimensions of Combustibles above Fireplace**

**CAUTION**

**IF JOINTS BETWEEN THE FINISHED WALLS AND THE FIREPLACE SURROUND (TOP AND SIDES) ARE SEALED, A 300° F. MINIMUM SEALANT MATERIAL MUST BE USED. THESE JOINTS ARE NOT REQUIRED TO BE SEALED. ONLY NON-COMBUSTIBLE MATERIAL (USING 300° F. MINIMUM ADHESIVE, IF NEEDED) CAN BE APPLIED AS FACING TO THE FIREPLACE SURROUND ABOVE THE GLASS. SEE DIAGRAM BELOW.**

1. Apply only non-combustible facing material to the fireplace surround ABOVE glass opening.



**Figure 29. Sealant Material**



**WARNING: ONLY NON-COMBUSTIBLE MATERIALS MAY COVER FIREPLACE SURROUND ABOVE THE GLASS OPENING.**

2. Combustible finishing materials (including drywall) may cover areas BELOW the glass up to finishing tabs (see Figure 29).

**Hearth Extensions**

A hearth extension may be desirable for aesthetic reasons. However, ANSI or CAN/CGA testing standards **do not** require hearth extensions for gas fireplace appliances. Refer to Figures 1, 2, and 3 for requirements and dimensions.

## Step 10 Installing Trim, Logs, and Ember Material

### Installing the Trim

Combustible materials may be brought up to the specified clearances on the side and top front edges of the fireplace, but **MUST NEVER** overlap onto the front face. The joints between the finished wall and the fireplace top and sides can only be sealed with a 300° F. (149° C) minimum sealant. Combustible material may overlap below the glass.



**WARNING: WHEN FINISHING THE FIREPLACE, NEVER OBSTRUCT OR MODIFY THE GLASS RETENTION CLIP OR VALVE ACCESS OPENINGS.**

1. Install surround hanger brackets below non-combustible board above the glass. Using (4) screws from manual bag - secure in place with two screws each.

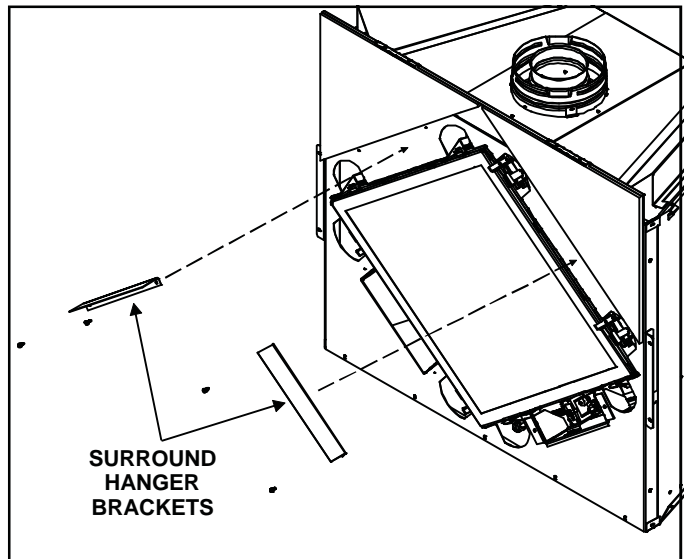

**Figure 30. Install surround hanger brackets**

Marble, brass, brick, tile, or other non-combustible materials can be used to cover up the areas around the surround. When overlapping, be sure not to obstruct the surround hanger brackets, glass retention clip opening, or valve access openings. Refer to Figure 1. The standard decorative surround (diamond shaped) should never be fixed in place.

### Shutter Settings

	NG	LP
Burner	3/8"	SET



### Positioning the Logs

Logs provided with this fireplace have been packaged separately, refer to the installation instructions that accompany the logs. **Save the log instructions with this manual.**

If sooting occurs, the logs might need to be repositioned slightly to avoid excessive flame impingement.

### Placing the Ember Material

Three separate bags of ember material are shipped with this gas fireplace:

- The bag labeled Golden Ember (GE-93) is flame colorant material.
- The bags labeled Glowing Ember (050-721) are standard glowing ember material.

To place the ember material:

- Pull and release each of the glass clips around the glass door.
- Remove the glass door from the unit.
- Cover the top of the burner with a single layer of ember material. Then sprinkle GE-93 on top of the burner.



**WARNING: EMBER MATERIAL MUST NOT BLOCK BURNER PORTS. POSITION CLOSELY ON EITHER SIDE OF PORT HOLES.**

- Save the remaining ember materials for use during fireplace servicing.
- Replace the glass door on the unit (see Service Parts List Section of the manual.) Be certain each of the 8 glass retention clips are pulled and secured on the glass door frame.
- Replace decorative surround.

1. Lift the trim door up and away from the unit.
2. Release the glass retention clips surrounding glass door by pulling or clips.

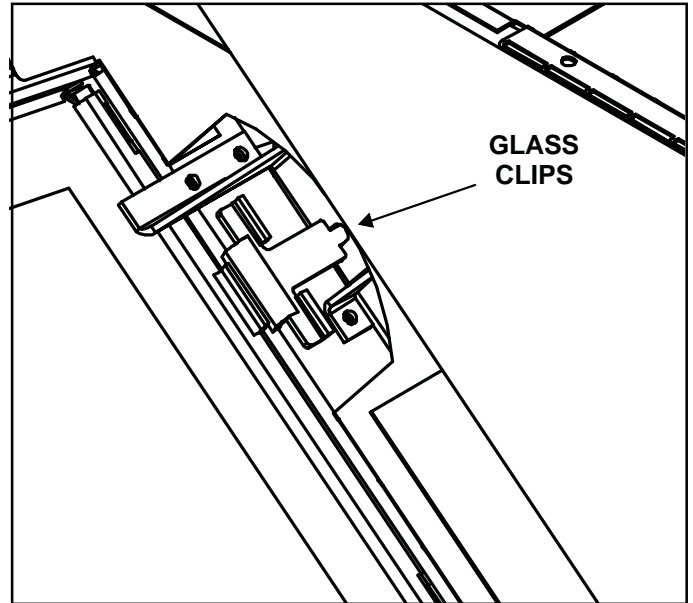

Figure 31. Glass Assembly

**CAUTION**

- Place a dime size piece of mineral wool ember material near port holes in burner top. See Figure 32.
- Space ember pieces about a 1/2 inch apart.
- Embers should be set onto burner top, never press embers into burner ports.
- The embers provided are sufficient for 2 to 4 applications.

**HAND TIGHTEN THE WING NUT BUT BE CAREFUL NOT TO OVERTIGHTEN.**

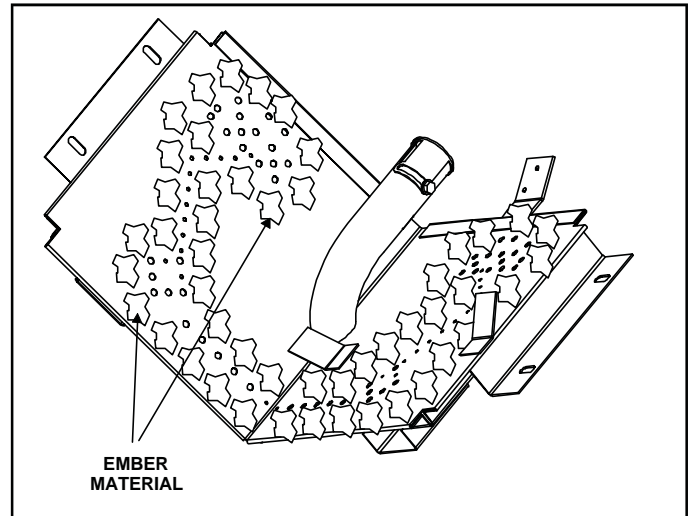

Figure 32. Placement of the ember material

**CAUTION**

**IT IS STRONGLY RECOMMENDED THAT OPTIONAL MESH SCREENS BE INSTALLED ONTO THE DECORATIVE SURROUND/TRIM DOOR ON PROPANE MODELS.**

## Step 11 Before Lighting the Fireplace

**Before** lighting the fireplace, be sure to do the following:

**Remove all paperwork and documents from the fireplace.**

**Review safety warnings and cautions**

- Read the **Safety and Warning Information** section at the beginning of this *Installers Guide*.

**Double-check for gas leaks**

- Before lighting the fireplace, double-check the unit for possible gas leaks.

**Double-check vent terminations for obstructions.**

- Before lighting the fireplace, double-check the unit for possible obstructions that could be blocking the vent terminations.

**Double-check for faulty components**

- Any component that is found to be faulty **MUST BE** replaced with an approved component. Tampering with the fireplace components is **DANGEROUS** and voids all warranties.

A small amount of air will be in the gas supply lines. When first lighting the fireplace, it will take a few minutes for the lines to purge themselves of this air. Once the purging is complete, the fireplace will light and will operate normally.

Subsequent lightings of the fireplace will not require this purging of air from the gas supply lines, **unless the gas valve has been turned to the OFF position**, in which case the air would have to be purged.

**NOTE:** The fireplace should be run 3 to 4 hours on the initial start-up. Turn it off and let it cool completely. Remove and clean the glass. Replace the glass and run the fireplace for an additional 8 hours. This will help to cure the chemicals used in the paint and logs.

You've reviewed all safety warnings, you've checked the fireplace for gas leaks, you know the vent system is unobstructed, and you've checked for faulty components. Now you're ready to light the fireplace.



**WARNING: PLEASE REFER TO THE USER'S MANUAL FOR ALL CAUTIONS, SAFETY, AND WARNING INFORMATION PERTAINING TO THE LIGHTING AND OPERATION OF THE FIREPLACE.**



**LEAVE THIS INSTALLATION MANUAL WITH THE APPLIANCE FOR FUTURE REFERENCE.**

## Step 12 Lighting the Fireplace

## After the Installation

# 4

## Maintaining and Servicing Your Fireplace

### Fireplace Maintenance

Although the frequency of your fireplace servicing and maintenance will depend on use and the type of installation, you should have a qualified service technician perform an appliance check-up at the beginning of each heating season. See the table below for specific guidelines regarding each fireplace maintenance task.

#### **IMPORTANT**

**TURN OFF THE GAS BEFORE SERVICING YOUR FIREPLACE.**

Type of Fireplace Maintenance	Frequency	By	Fireplace Maintenance Task To Be Completed
<b>Replacing Old Ember Material</b>	Once annually, during the annual check-up	Qualified Service Technician	Brush away loose ember material near the burner. Replace old ember material with new dime-size and -shape pieces of Golden Ember (GE-93) and Glowing Ember (050-721). New ember material should be placed alternately on top of the burner—a layer of Golden Ember, a layer of Glowing Ember, and so on. Save the remaining ember material and repeat this procedure at your next servicing. For more information, see <b>Placing Ember Material</b> in this manual.
<b>Cleaning Burner &amp; Controls</b>	Once annually	Qualified Service Technician	Brush or vacuum the control compartment, fireplace logs, and burner areas surrounding the logs.
<b>Checking Flame Patterns, Flame Height</b>	Periodically	Qualified Service Technician/ Owner	Make a visual check of your fireplace's flame patterns. Make sure the flames are steady—not lifting or floating. See the picture in Figure 33. The flame sensor tips should be covered with flame. See the picture in Figure 34.
<b>Checking Vent System</b>	Before initial use and at least annually thereafter, more frequently if possible	Qualified Service Technician/ Owner	Inspect the external vent cap on a regular basis to ensure that no debris is interfering with the flow of air. Inspect the entire vent system for proper function.
<b>Cleaning Glass Door</b>	As necessary	Homeowner	Remove and clean glass after the first 3 to 4 hours of use. After the initial cleaning, clean as necessary, particularly after adding new ember (flame colorant) material. Film deposits on the inside of the glass door should be cleaned off using a household glass cleaner. <b>NOTE: DO NOT handle or attempt to clean the door when it is hot and DO NOT use abrasive cleaners.</b>

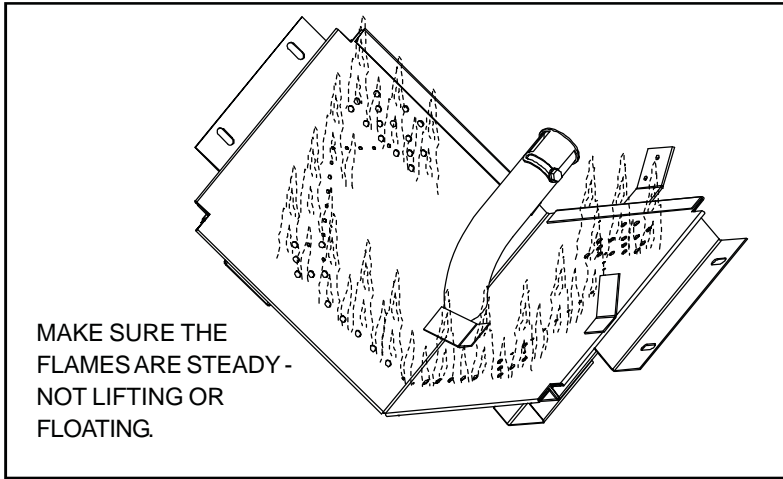

Figure 33. Burner Flame Patterns

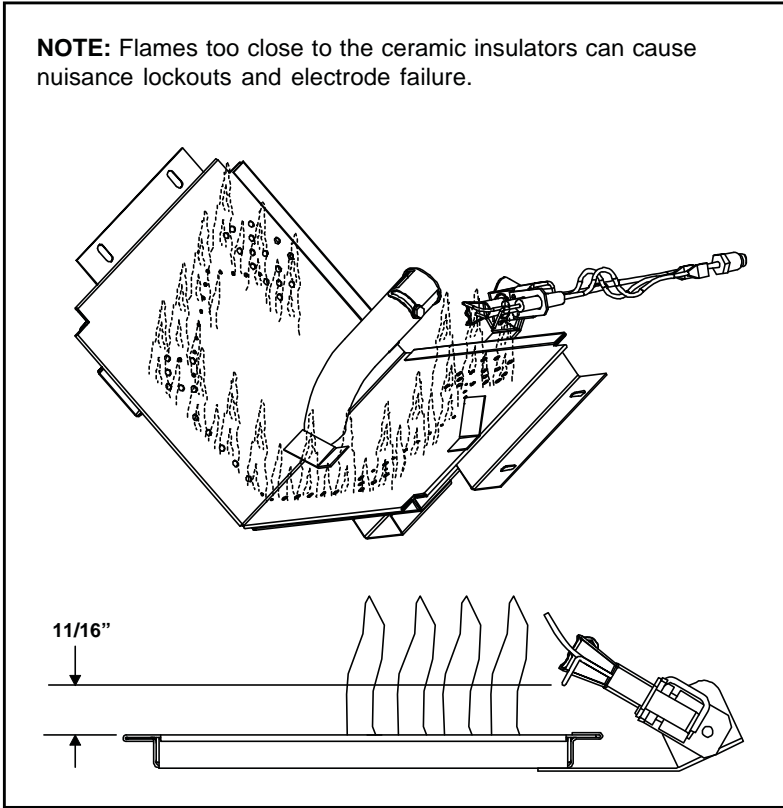

Figure 34. Ignitor Flame Patterns