

This appliance has been retired.
Service parts pages within have been removed.
For replacement parts, please refer to the individual
service parts list located on the brand websites.

HEAT-N-GLO
No one builds a better fire

**Model:
HV-CDN**

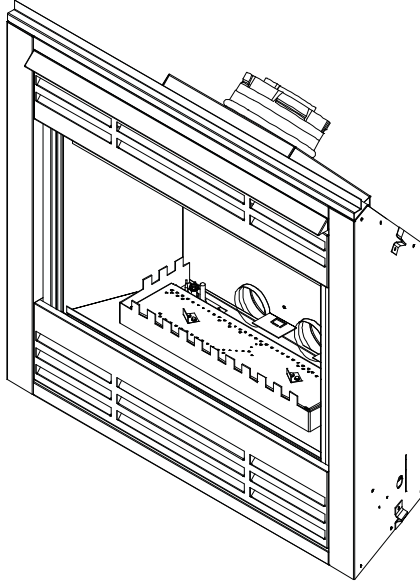

Installers Guide



Underwriters
Laboratories Listed

WARNING: IF THE INFORMATION IN THESE INSTRUCTIONS IS NOT FOLLOWED EXACTLY, A FIRE OR EXPLOSION MAY RESULT CAUSING PROPERTY DAMAGE, PERSONAL INJURY, OR DEATH.

- Do not store or use gasoline or other flammable vapors and liquids in the vicinity of this or any other appliance.
- **What to do if you smell gas**
 - Do not try to light any appliance.
 - Do not touch any electrical switch.
 - Do not use any phone in your building.
 - Immediately call your gas supplier from a neighbor's phone. Follow the gas supplier's instructions.
 - If you cannot reach your gas supplier, call the fire department.
- Installation and service must be performed by a qualified installer, service agency, or the gas supplier.

READ THIS MANUAL BEFORE INSTALLING OR OPERATING THIS APPLIANCE. THIS *INSTALLERS GUIDE* MUST BE LEFT WITH APPLIANCE FOR FUTURE REFERENCE.

WARNING: IMPROPER INSTALLATION, ADJUSTMENT, ALTERATION, SERVICE OR MAINTENANCE CAN CAUSE INJURY OR PROPERTY DAMAGE. REFER TO THIS MANUAL. FOR ASSISTANCE OR ADDITIONAL INFORMATION CONSULT A QUALIFIED INSTALLER, SERVICE AGENCY, OR THE GAS SUPPLIER.

1. This appliance may be installed in an aftermarket, permanently located, manufactured (mobile) home, where not prohibited by local codes.
2. This appliance is only for use with the type of gas indicated on the rating plate. This appliance is not convertible for use with other gases, unless a certified kit is used.

Printed in U.S.A. Copyright 2001,
Heat-N-Glo, a division of Hearth Technologies Inc.
20802 Kensington Boulevard, Lakeville, MN 55044

Please contact your Heat-N-Glo dealer with any questions or concerns. For the number of your nearest Heat-N-Glo dealer, please call 952-985-6000.

This product is covered by one or more of the following patents: (United States) 4,112,913; 4,408,594; 4,422,426; 4,424,792; 4,520,791; 4,793,322; 4,852,548; 4,875,464; 5,000,162; 5,016,609; 5,076,254; 5,191,877; 5,218,953; 5,328,356; 5,429,495; 5,452,708; 5,542,407; 5,613,487; (Australia) 543790; 586383; (Canada) 1,123,296; 1,297,746; 2,195,264; (Mexico) 97-0457; (New Zealand) 200265; or other U.S. and foreign patents pending.

589-900D 07/01 Rev F

SAFETY AND WARNING INFORMATION

 **READ** and **UNDERSTAND** all instructions carefully before starting the installation. **FAILURE TO FOLLOW** these installation instructions may result in a possible fire hazard and will void the warranty.

 Prior to the first firing of the fireplace, **READ** the Using Your Fireplace section of the *Owners Guide*.

 **DO NOT USE** this appliance if any part has been under water. Immediately **CALL** a qualified service technician to inspect the unit and to replace any part of the control system and any gas control which has been under water.

 **THIS UNIT IS NOT FOR USE WITH SOLID FUEL.**

 Installation and repair should be **PERFORMED** by a qualified service person. The appliance and venting system should be **INSPECTED** before initial use and at least annually by a professional service person. More frequent cleaning may be required due to excessive lint from carpeting, bedding material, etc. It is **IMPERATIVE** that the unit's control compartment, burners, and circulating air passageways **BE KEPT CLEAN** to provide for adequate combustion and ventilation air.

 Always **KEEP** the appliance clear and free from combustible materials, gasoline, and other flammable vapors and liquids.

 **NEVER OBSTRUCT** the flow of combustion and ventilation air. Keep the front of the appliance **CLEAR** of all obstacles and materials for servicing and proper operations.

 Due to the high temperature, the appliance should be **LOCATED** out of traffic areas and away from furniture and draperies. Clothing or flammable material **SHOULD NOT BE PLACED** on or near the appliance.

 Children and adults should be **ALERTED** to the hazards of high surface temperature and should **STAY AWAY** to avoid burns or clothing ignition. Young children should be **CAREFULLY SUPERVISED** when they are in the same room as the appliance.

 These units **MUST** use one of the vent systems described in the Installing the Fireplace section of the *Installers Guide*. **NO OTHER** vent systems or components **MAY BE USED**.

 This gas fireplace and vent assembly **MUST** be vented directly to the outside and **MUST NEVER** be attached to a chimney serving a separate solid fuel burning appliance. Each gas appliance **MUST USE** a separate vent system. Common vent systems are **PROHIBITED**.

 **INSPECT** the external vent cap on a regular basis to make sure that no debris is interfering with the air flow.

 The glass door assembly **MUST** be in place and sealed, and the trim door assembly **MUST** be in place on the fireplace before the unit can be placed into safe operation.

 **DO NOT OPERATE** this appliance with the glass door removed, cracked, or broken. Replacement of the glass door should be performed by a licensed or qualified service person. **DO NOT** strike or slam the glass door.

 The glass door assembly **SHALL ONLY** be replaced as a complete unit, as supplied by the gas fireplace manufacturer. **NO SUBSTITUTE** material may be used.

 **DO NOT USE** abrasive cleaners on the glass door assembly. **DO NOT ATTEMPT** to clean the glass door when it is hot.

 Turn off the gas before servicing this appliance. It is recommended that a qualified service technician perform an appliance check-up at the beginning of each heating season.

 Any safety screen or guard removed for servicing must be replaced before operating this appliance.

 **DO NOT** place furniture or any other combustible household objects within 36 inches of the fireplace front.

TABLE OF CONTENTS

◆ Safety and Warning Information	2
◆ Service Parts List	4
Section 1: Approvals and Codes	6
◆ Appliance Certification	6
Installation Codes	6
High Altitude Installations	6
Section 2: Getting Started	7
Introducing the Heat-N-Glo Gas Fireplaces	7
Pre-installation Preparation	7
Section 3: Installing the Fireplace	9
◆ Constructing the Chase	9
◆ Step 1 Locating the Fireplace	9
Step 2 Framing the Fireplace	10
Step 3 Installing the Vent System	12
◆ A. Vent System Approvals	12
◆ B. Installing Vent Components	17
C. Vent Termination	20
Step 4 Positioning, Leveling, and Securing the Fireplace	23
Step 5 The Gas Control Systems	23
◆ Step 6 The Gas Supply Line	24
Step 7 Gas Pressure Requirements	24
◆ Step 8 Wiring the Fireplace	25
Step 9 Finishing	26
Step 10 Installing Trim, Logs, and Ember Material	27
Installing the Trim	27
Placing the Ember Material and Vermiculite	27
◆ Glass Specifications	27
Log Placement Instructions	28
◆ Step 11 Before Lighting the Fireplace	30
Step 12 Lighting the Fireplace	30
After the Installation	30
◆ Section 4: Maintaining and Servicing Your Fireplace	31

◆ = Contains updated information.

1

Approvals and Codes

Appliance Certification

The Heat-N-Glo fireplace model discussed in this *Installers Guide* has been tested to certification standards and listed by the applicable laboratories.

Certification
MODEL: HV-CDN
LABORATORY: Underwriters Laboratories
TYPE: Direct Vent Gas Fireplace
STANDARD: ANSI Z21.50-1998/CSA 2.22-M98 ANSI Z21.50b-2000/CSA 2.22b-2000 UL307B

NOTE: THIS MODEL IS UL LISTED TO UL307B, THE STANDARD FOR GAS-BURNING HEATING APPLIANCES FOR MANUFACTURED HOMES AND RECREATIONAL VEHICLES.

Installation Codes

The fireplace installation must conform to local codes. Before installing the fireplace, consult the local building code agency to ensure that you are in compliance with all applicable codes, including permits and inspections.

In the absence of local codes, the fireplace installation must conform to the National Fuel Gas Code ANSI Z223.1 (in the United States) or the CAN/CGA-B149 Installation Codes

(in Canada). The appliance must be electrically grounded in accordance with local codes or, in the absence of local codes with the National Electric Code ANSI/NFPA No. 70 (in the United States), or to the CSA C22.1 Canadian Electric Code (in Canada).

These models may be installed in a bedroom or bed-sitting room in the U.S.A. and Canada.

High Altitude Installations

U.L. Listed gas fireplaces are tested and approved for elevations from 0 to 2,000 feet in the U.S.A. and from 0 to 4,500 feet in Canada.

When installing this fireplace at an elevation above 2,000 feet (in the United States), it may be necessary to decrease the input rating by changing the existing burner orifice to a smaller size. Input should be reduced four percent (4%) for each 1,000 feet above sea level, unless the heating value of the gas has been reduced, in which case this general rule will not apply. To identify the proper orifice size, check with the local gas utility.

When installing this fireplace at an elevation between 2,000 and 4,500 feet (in Canada), the input rating must be reduced by ten percent (10%).

When installing this fireplace at an elevation above 4,500 feet (in Canada), check with local authorities.

Consult your local gas utility for assistance in determining the proper orifice for your location.

2

Getting Started

Introducing the Heat-N-Glo Gas Fireplaces

Heat-N-Glo direct vent gas fireplaces are designed to operate with all combustion air siphoned from outside of the building and all exhaust gases expelled to the outside.

The information contained in this *Installers Guide*, unless noted otherwise, applies to all models and gas control systems. Gas fireplace diagrams, including the dimensions, are shown in this section.

Pre-install Preparation

This gas fireplace and its components are tested and safe when installed in accordance with this *Installers Guide*. Report to your dealer any parts damaged in shipment, particularly the condition of the glass. **Do not install any unit with damaged, incomplete, or substitute parts.**

The vent system components and optional trim doors are shipped in separate packages. The gas logs are packaged separately and must be field installed.

Read all of the instructions before starting the installation. Follow these instructions carefully during the installation to ensure maximum safety and benefit. Failure to follow these instructions will void the owner's warranty and may present a fire hazard.

The Heat-N-Glo Warranty will be voided by, and Heat-N-Glo disclaims any responsibility for, the following actions:

- Installation of any damaged fireplace or vent system component.
- Modification of the fireplace or direct vent system.
- Installation other than as instructed by Heat-N-Glo.
- Improper positioning of the gas logs or the glass door.
- Installation and/or use of any component part not manufactured and approved by Heat-N-Glo, notwithstanding any independent testing laboratory or other party approval of such component part or accessory.

ANY SUCH ACTION MAY POSSIBLY CAUSE A FIRE HAZARD.

When planning a fireplace installation, it's necessary to determine:

- Where the unit is to be installed.
- The vent system configuration to be used.
- Gas supply piping.
- Electrical wiring.
- Framing and finishing details.
- Whether optional accessories—devices such as a fan, wall switch, or remote control—are desired.

If the fireplace is to be installed on carpeting or tile, or on any combustible material other than wood flooring, the fireplace should be installed on a metal or wood panel that extends the full width and depth of the fireplace.

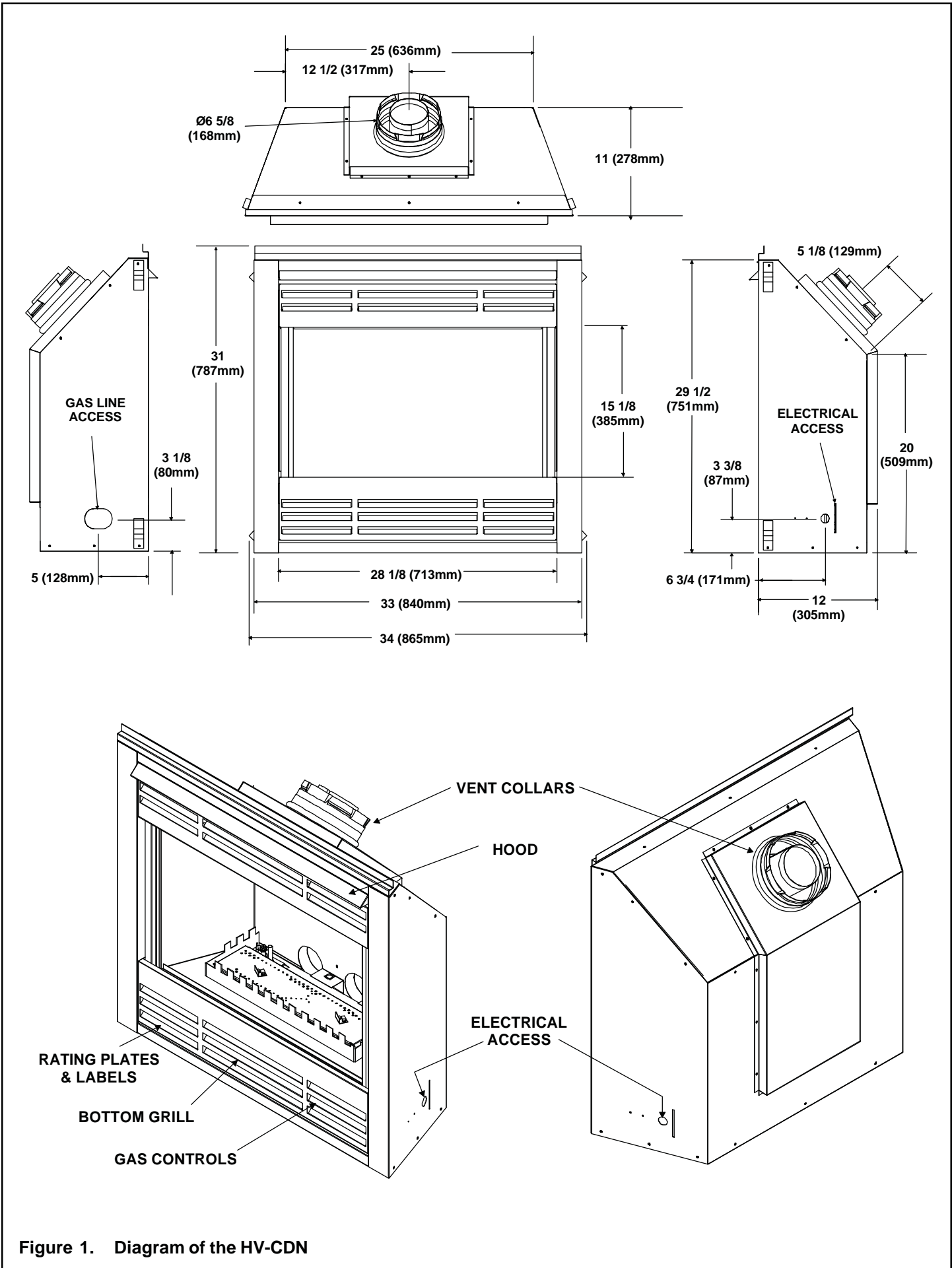

Figure 1. Diagram of the HV-CDN

3

Installing the Fireplace

Constructing the Chase

A chase is a vertical box-like structure built to enclose the gas fireplace and/or its vent system. Vertical vents that run on the outside of a building may be, but are not required to be, installed inside a chase.

CAUTION: TREATMENT OF FIRESTOP SPACERS AND CONSTRUCTION OF THE CHASE MAY VARY WITH THE TYPE OF BUILDING. THESE INSTRUCTIONS ARE NOT SUBSTITUTES FOR THE REQUIREMENTS OF LOCAL BUILDING CODES. THEREFORE, YOUR LOCAL BUILDING CODES **MUST** BE CHECKED TO DETERMINE THE REQUIREMENTS FOR THESE STEPS.

Factory-built fireplace chases should be constructed in the manner of all outside walls of the home to prevent cold air drafting problems. The chase should not break the outside building envelope in any manner.

This means that the walls, ceiling, base plate and cantilever floor of the chase should be insulated. Vapor and air infiltration barriers should be installed in the chase as per regional codes for the rest of the home. Additionally, Heat-N-Glo recommends that the inside surfaces be sheetrocked and taped for maximum air tightness.

To further prevent drafts, the firestops should be caulked to seal gaps. Gas line holes and other openings should be caulked or stuffed with insulation. If the unit is being installed on a cement slab, we recommend that a layer of plywood be placed underneath to prevent conducting cold up into the room. Be sure to include spark arrestors for woodburning units if they are required.

THE CHASE SHOULD BE CONSTRUCTED SO THAT ALL CLEARANCES TO THE FIREPLACE ARE MAINTAINED AS SPECIFIED WITHIN THIS INSTALLERS GUIDE.

Step 1. Locating the Fireplace

Figure 2 shows space and clearance requirements for locating a fireplace within a room.

Clearance Requirements

The top and back of the fireplace are defined by stand-offs. The minimum clearance to a perpendicular wall extending past the face of the fireplace is 3 inches (76.2mm). The back of the fireplace may be recessed 17 1/2 inches (445mm) into combustible construction.

The distance from the unit to combustible construction is to be measured from the unit outer wrap surface to the combustible construction, NOT from the screw heads that secure the unit together.

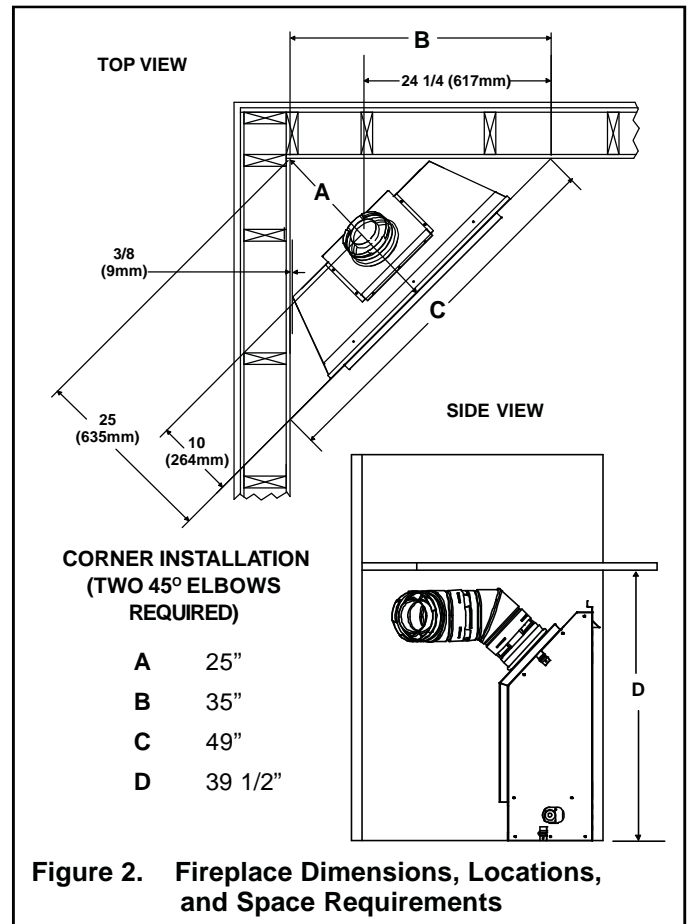

Figure 2. Fireplace Dimensions, Locations, and Space Requirements

Minimum Clearances from the Fireplace to Combustible Materials

	Inches	mm
Glass Front	36	914
Floor	0	0
Rear	1/2	13
Sides	1/2	13
Top	1 1/2	38
Ceiling*	35 1/2	902

* The clearance to the ceiling is measured from the top of the unit (see Figure 28).

Minimum Clearances from the Vent Pipe to Combustible Materials

	Inches	mm
Vertical Sections	1	25
Horizontal Sections		
Top	3	75
Bottom	1	25
Sides	1	25
At Wall Firestops		
Top	2 1/2	63.7
Bottom	1/2	13
Sides	1	25

For minimum clearances, see the direct vent termination clearance diagrams (Figures 20 and 21).

Step 2. Framing the Fireplace

Fireplace framing can be built before or after the fireplace is set in place. Framing should be positioned to accommodate wall coverings and fireplace facing material. The diagram below shows framing reference dimensions.

CAUTION: MEASURE FIREPLACE DIMENSIONS AND VERIFY FRAMING METHODS AND WALL COVERING DETAILS BEFORE FRAMING.

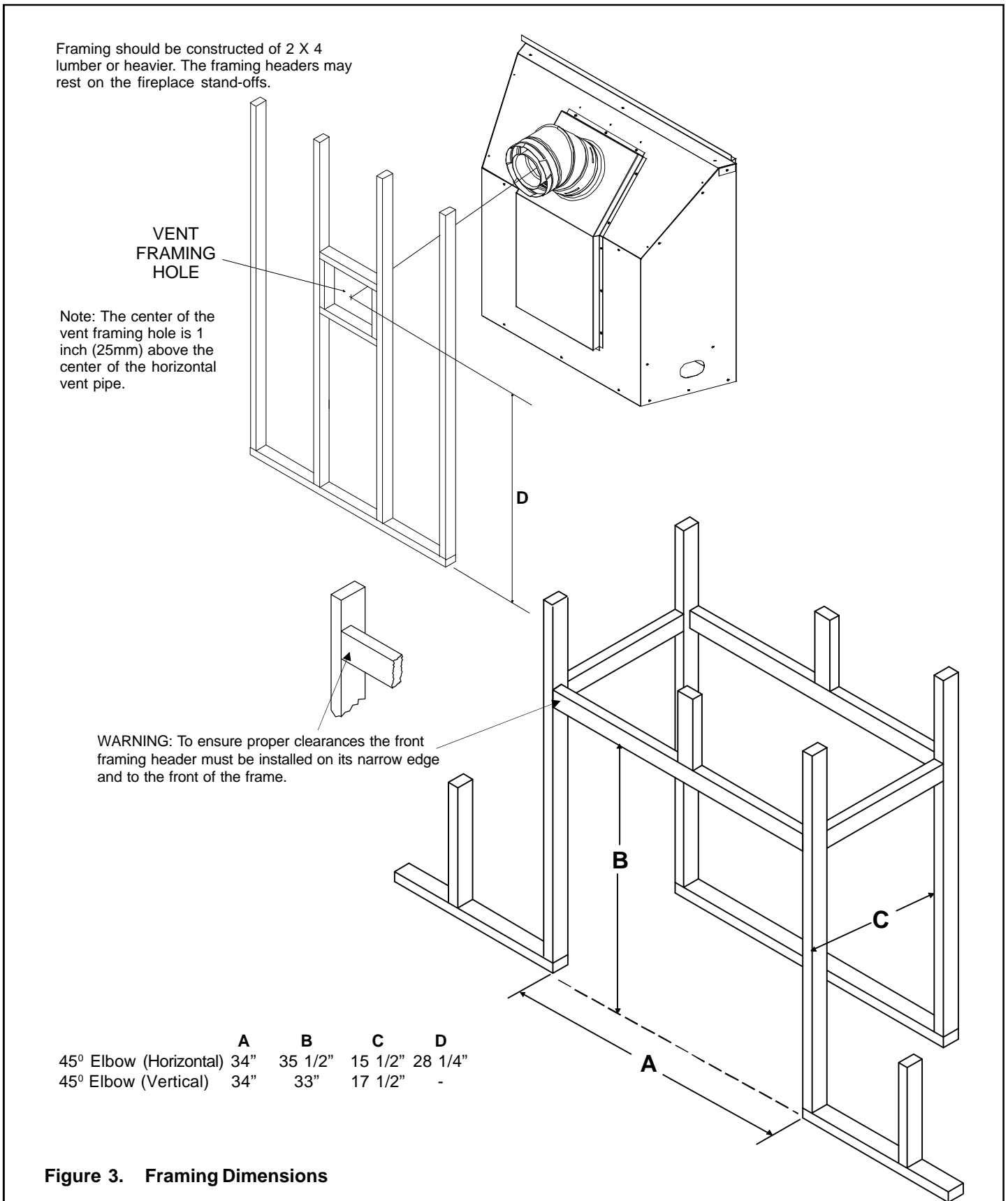

Figure 3. Framing Dimensions

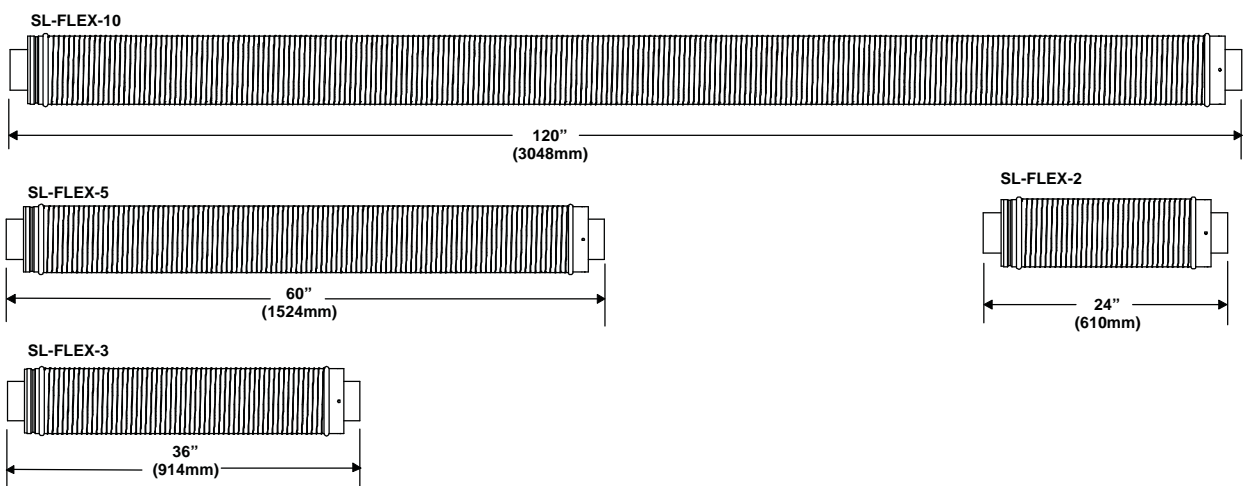
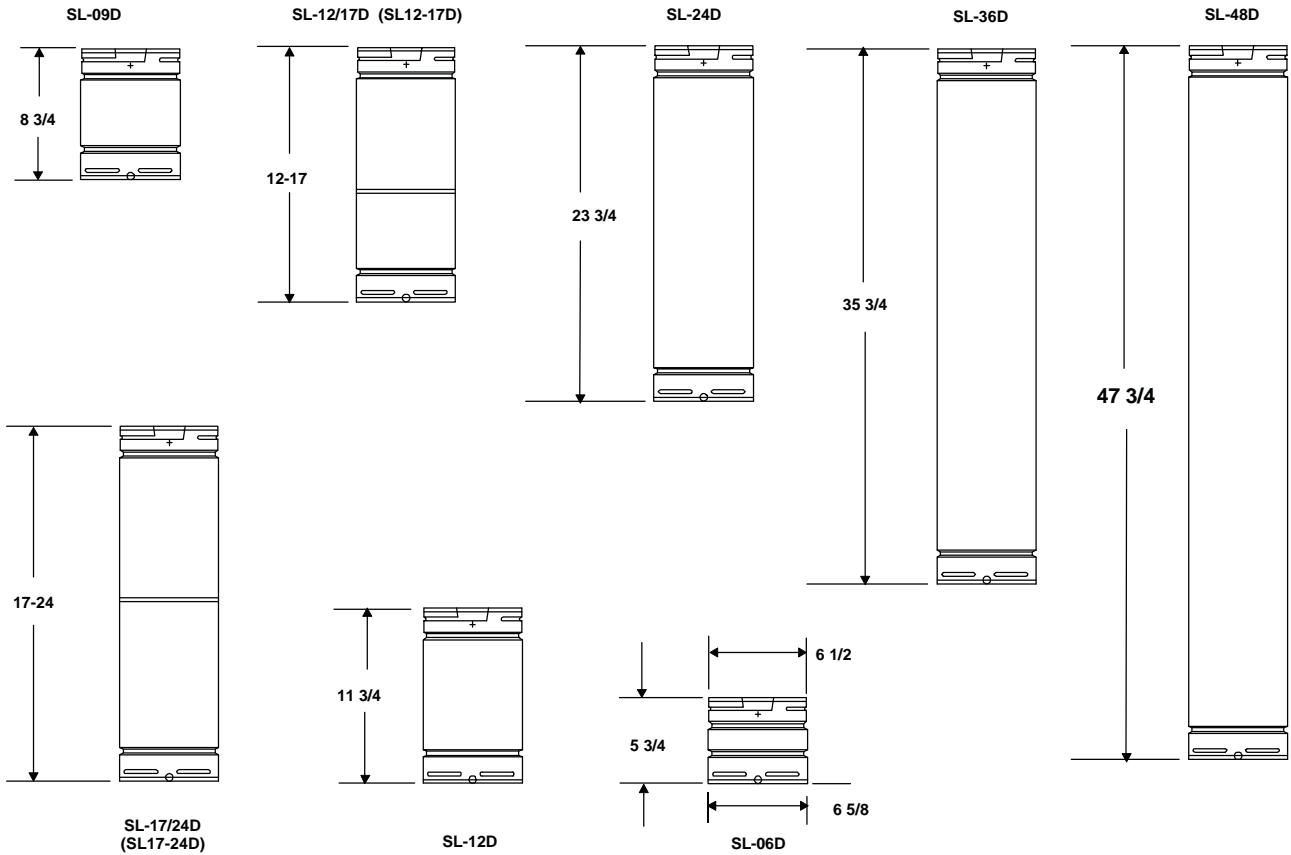
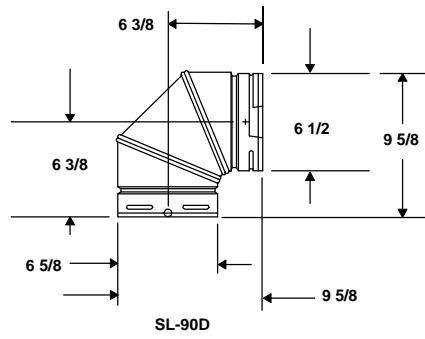
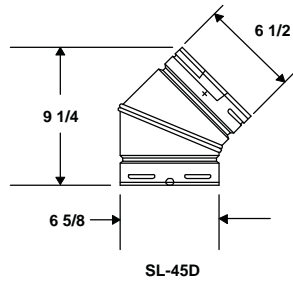

Figure 4. NOTE: PIPES OVERLAP 1-3/8 INCHES (34.93mm) AT EACH JOINT.
SL-Series and SL-Flex Series Direct Vent Component Specifications (4-inch inner pipe / 6 5/8-inch outer pipe)

Step 3. Installing the Vent System

A. Vent System Approvals

This model has vent starting collars on the back of the unit. This model uses SL D-series direct vent and SL-Flex vent components (see Figures 4 and 5). Approved vent system components are labeled for identification. This pipe is tested and listed as an approved component of the fireplace. The pipe is tested to be run inside an enclosed wall. There is no requirement for inspection openings at each joint within the wall. There is no required pitch for horizontal vent runs. **NO OTHER VENTING SYSTEMS OR COMPONENTS MAY BE USED.**

! WARNING: YOU MUST NOT MIX D-SERIES AND SL D-SERIES COMPONENTS IN ANY VENT SYSTEM CONFIGURATION.

Detailed installation instructions are included with each vent termination kit and should be used in conjunction with this *Installers Guide*.

The flame and ember appearance may vary based on the type of fuel burned and the venting configuration used.

Identifying Vent Components

The vent systems installed on this gas fireplace may include one, two, or three 90° elbow assemblies. The relationships of vertical rise to horizontal run in vent configurations using 90° elbows **MUST BE** strictly adhered to. The rise to run relationships are shown in the venting drawings and tables. Refer to the diagrams on the next several pages.

NOTE: Two 45° elbows may be used in place of one 90° elbow. You **MUST** always maintain the **MAXIMUM** and **MINIMUM** rise-to-run ratios in the vent system when using 45° elbows.

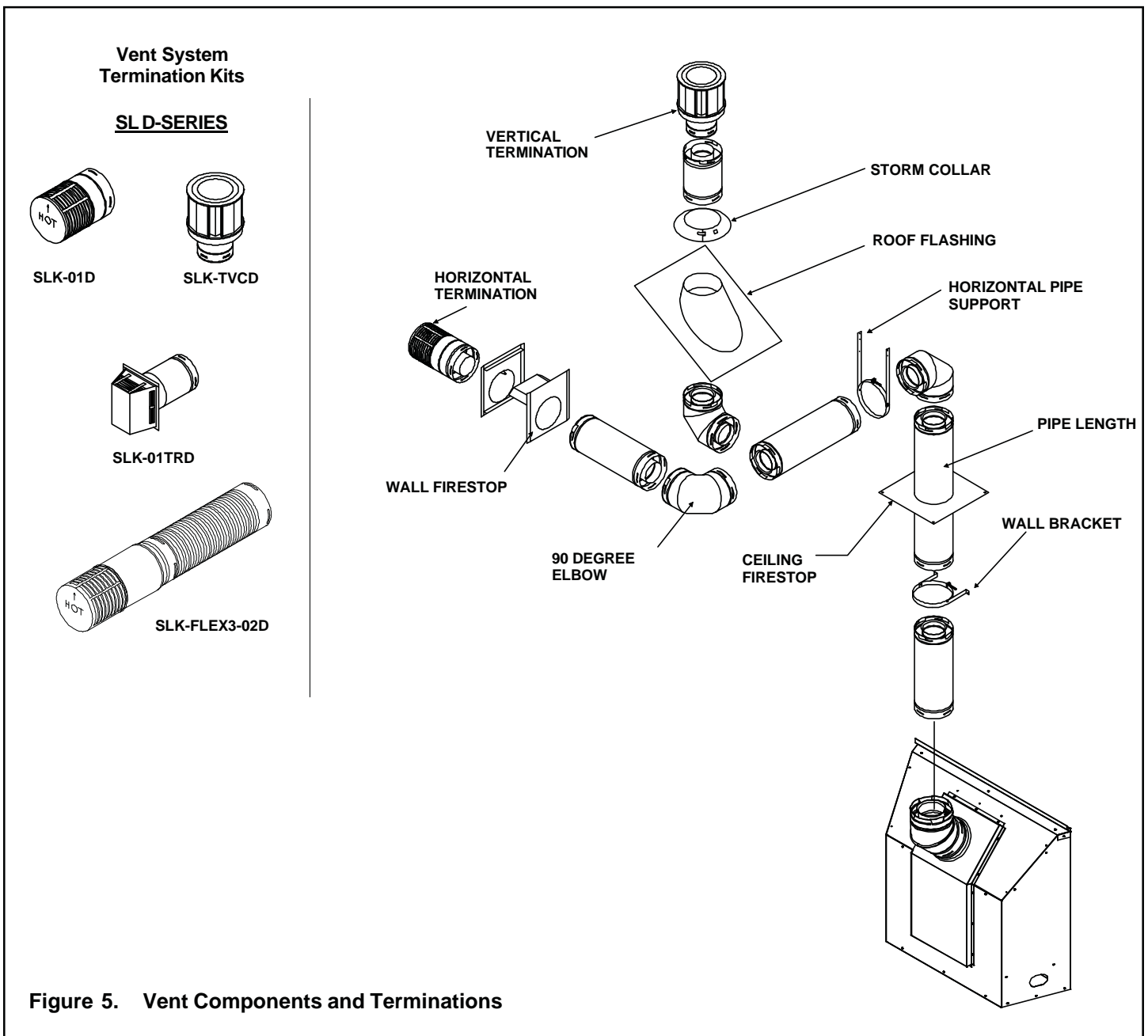

Figure 5. Vent Components and Terminations

**VERTICAL VENTING
WITH ONE 45° ELBOW**

V (FT.)
48 Ft. (14.6m) MAX.

Use SL D-Series
components only.

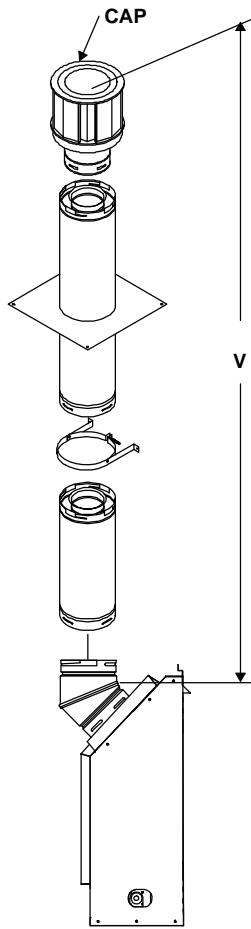
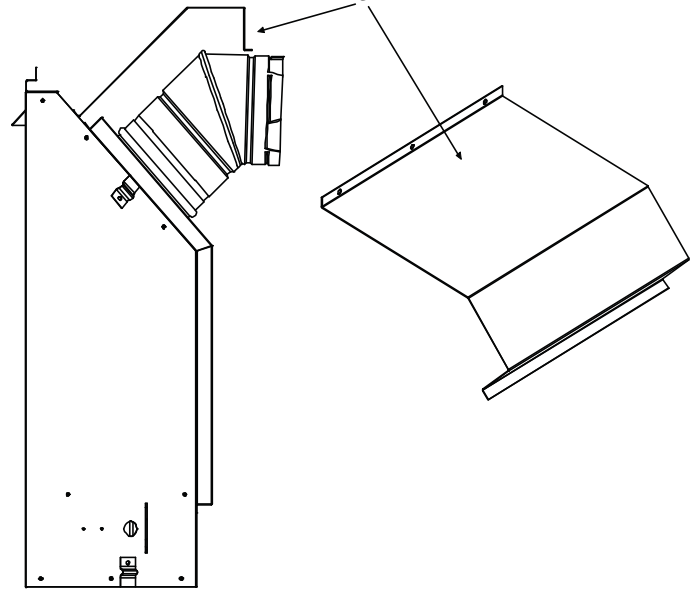

Figure 6. Vertical Venting One 45° Elbow

ELBOW
HEAT SHIELD



NOTE: For horizontal venting with enclosed elbow at unit an Elbow Heat Shield is required. Attach to unit as shown.

Figure 8. Elbow Heat Shield

**HORIZONTAL VENTING WITH
ONE 45° ELBOW**

H (MAX.)
3.0 FT (.91m)

NOTE: For horizontal venting with enclosed elbow at unit an Elbow Heat Shield is required. See Figure 8.

NOTE: There **MUST** be a 25% reduction in total H when using flex vent.

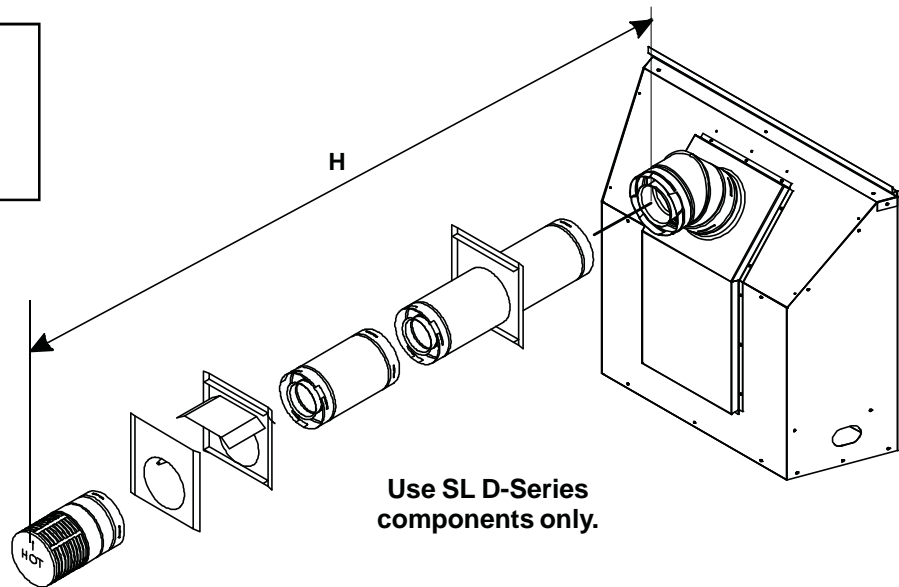

Use SL D-Series
components only.

Figure 7.
Horizontal Venting with
One 45° Elbow

NOTE: There MUST be a 25% reduction in total H when using flex vent.

Use SL D-Series components only.

VENTING WITH (1) 45° ELBOW and (1) 90° ELBOW	
V (MIN.)	H (MAX.)
1 FT (305mm)	3.5 FT (1.0m)
2 FT (610mm)	4 FT (1.22m)
3 FT (914mm)	6 FT (1.86m)
4 FT (1.22m)	8 FT (2.48m)
5 FT (1.52m)	16 FT (4.8m)
H MAX. = 16 FT (4.8m)	
V + H MAX. = 40 FT (12.2m)	

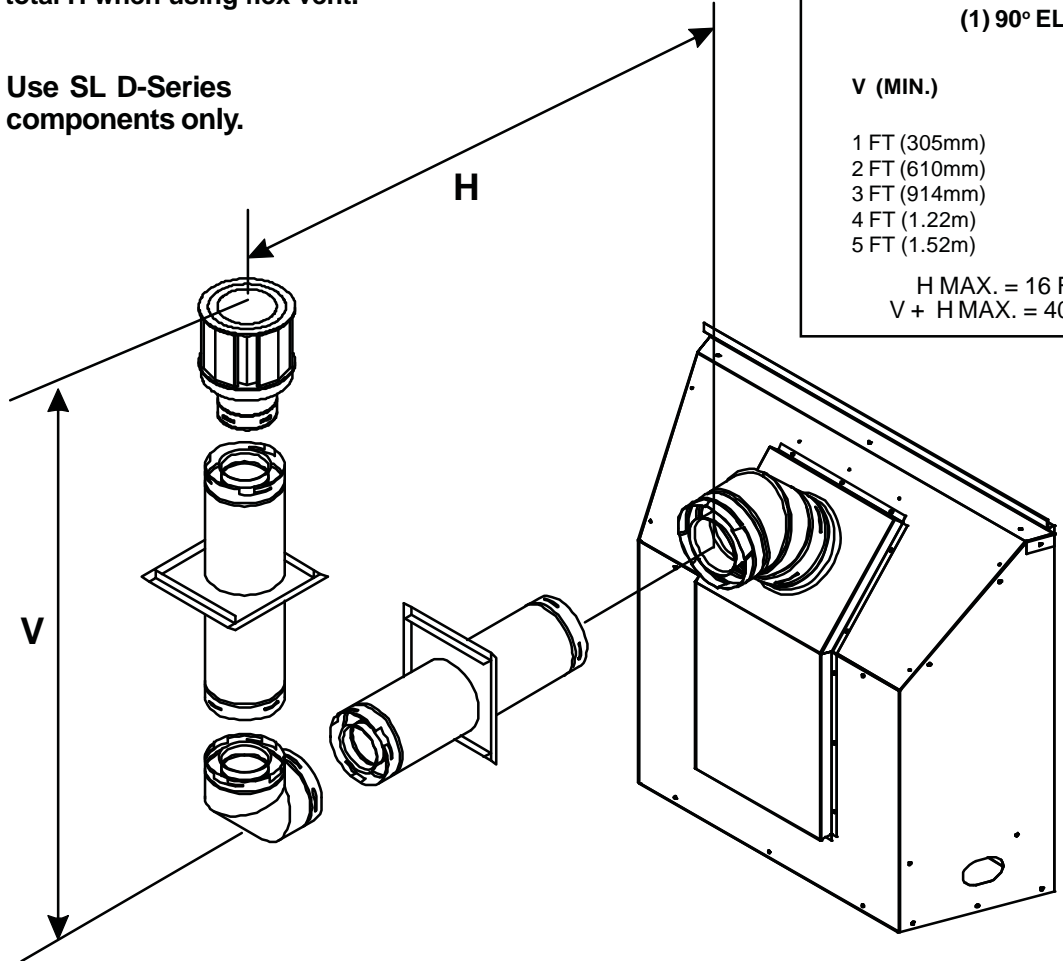

VENTING WITH (1) 45° and (1) 90° ELBOW	
H + H ₁ (MAX.)	
2.5 FT (762mm)	

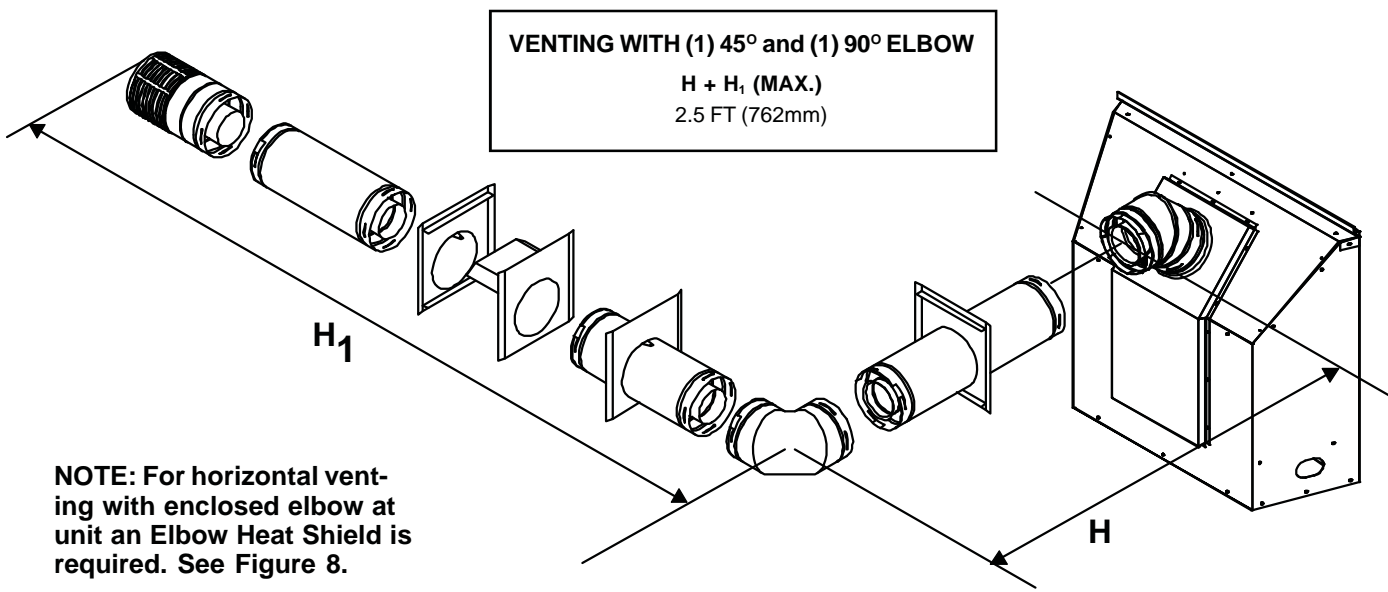

NOTE: For horizontal venting with enclosed elbow at unit an Elbow Heat Shield is required. See Figure 8.

Figure 9. Venting with (1) 45° Elbow and (1) 90° Elbow.

NOTE: There **MUST** be a 25% reduction in total H when using flex vent.

Use SL D-Series components only.

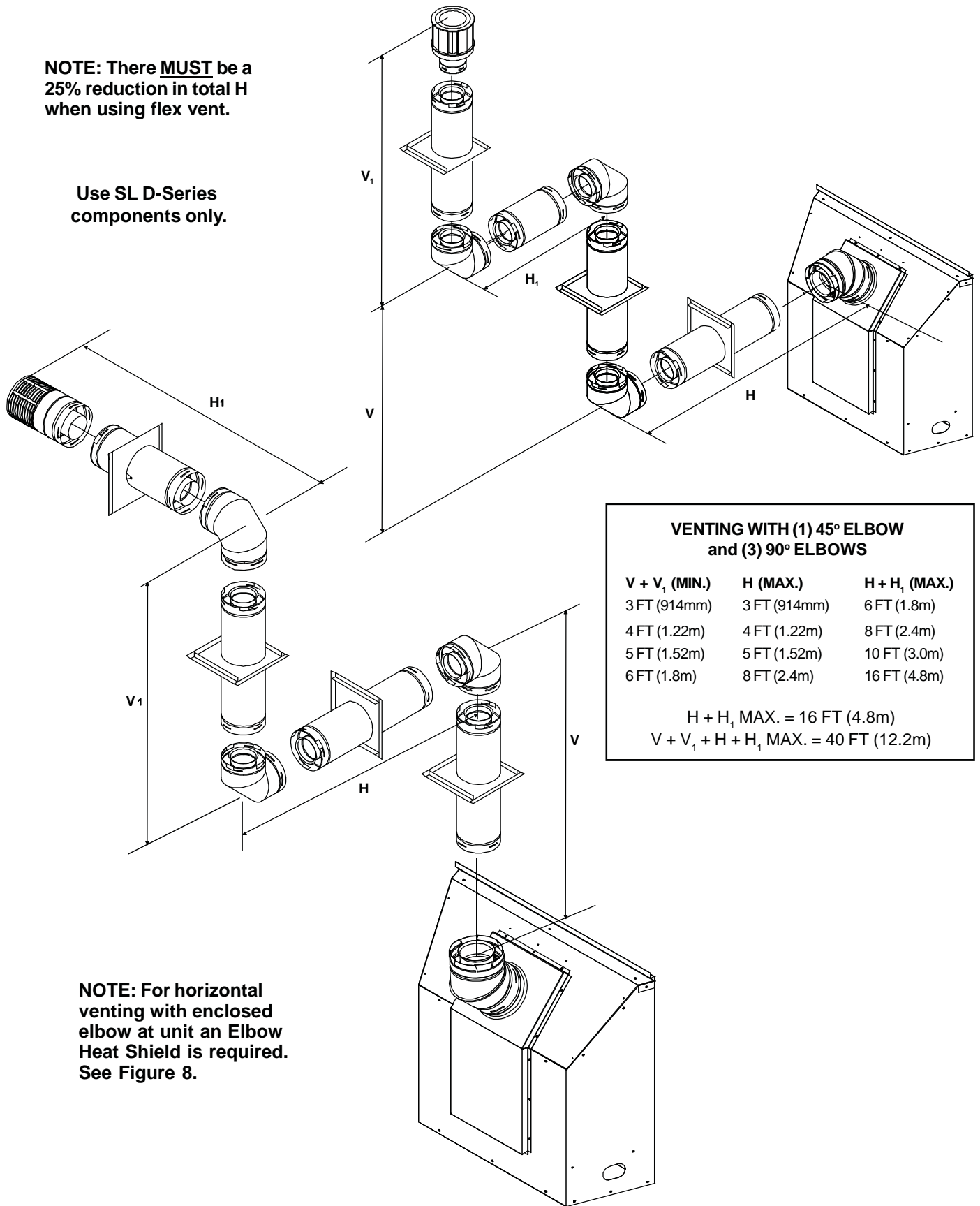

Figure 10. Venting with (1) 45° Elbow and (3) 90° Elbows.

**VENTING WITH (1) 45° ELBOW
and (2) 90° ELBOWS**

V (MIN.)	H + H ₁ (MAX.)
1 FT (305mm)	3.5 FT (1.0m)
2 FT (610mm)	6 FT (1.8m)
3 FT (914mm)	8 FT (2.4m)
4 FT (1.22m)	10 FT (3.0m)
5 FT (1.52m)	16 FT (4.8m)

H + H₁ MAX. = 16 FT (4.8m)
V + H + H₁ MAX. = 40 FT (12.2m)

NOTE: There MUST be a 25% reduction in total H when using flex vent.

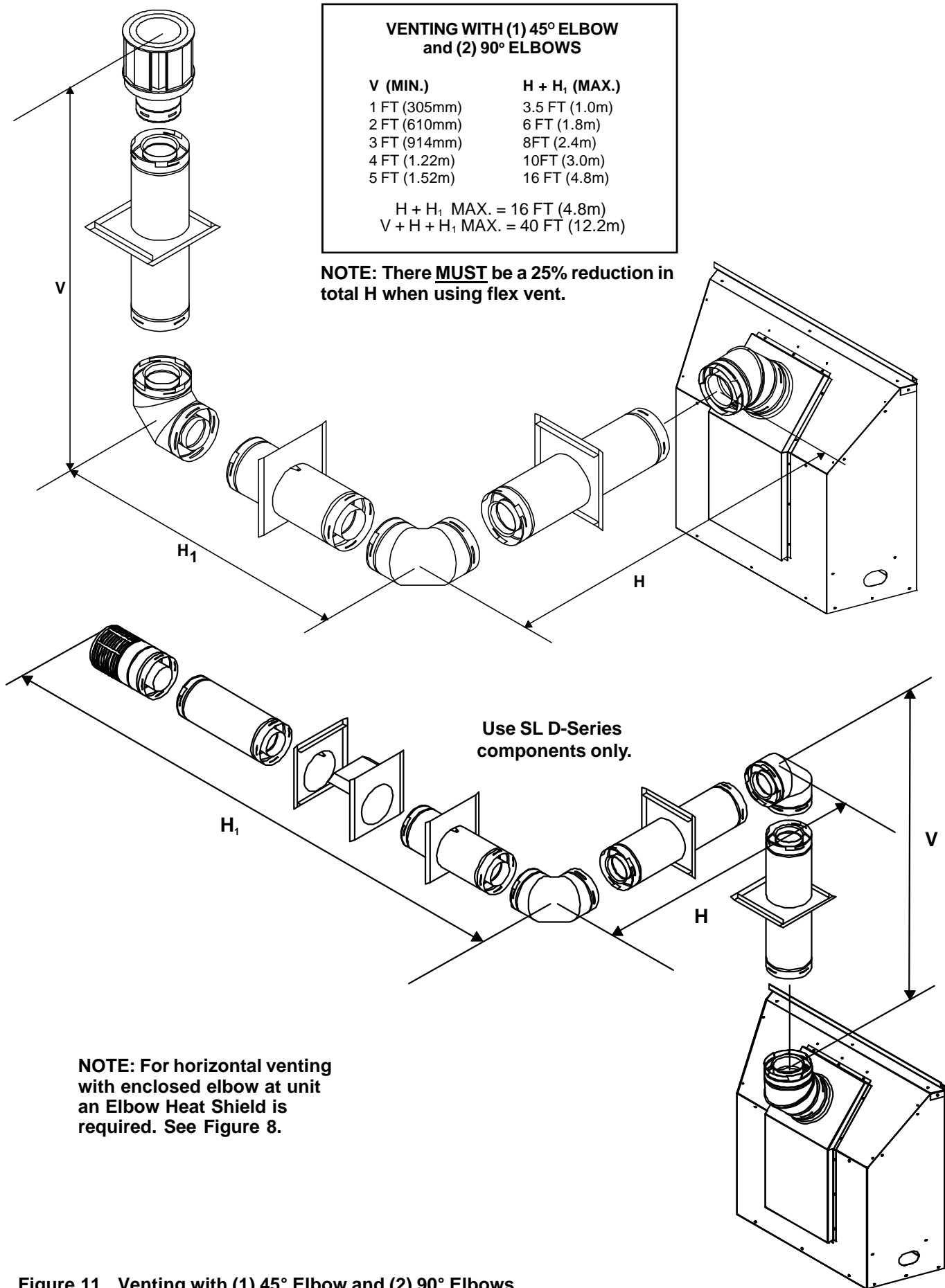

NOTE: For horizontal venting with enclosed elbow at unit an Elbow Heat Shield is required. See Figure 8.

Figure 11. Venting with (1) 45° Elbow and (2) 90° Elbows.

B. Installing Vent Components

1. Attach the First Vent Component to the Starting Collars

To attach the first vent component to the starting collars of the fireplace:

- Apply a 3/8 inch (9.5mm) bead of stove cement around the fireplace inner vent starting collar.
- Lock the vent components into place by sliding the concentric pipe sections with four (4) equally spaced interior beads into the fireplace collar or previously installed component end with four (4) equally spaced indented sections.
- When the internal beads of each outer pipe line up, rotate the pipe section clockwise about one-quarter (1/4) turn. The vent pipe is now locked together.

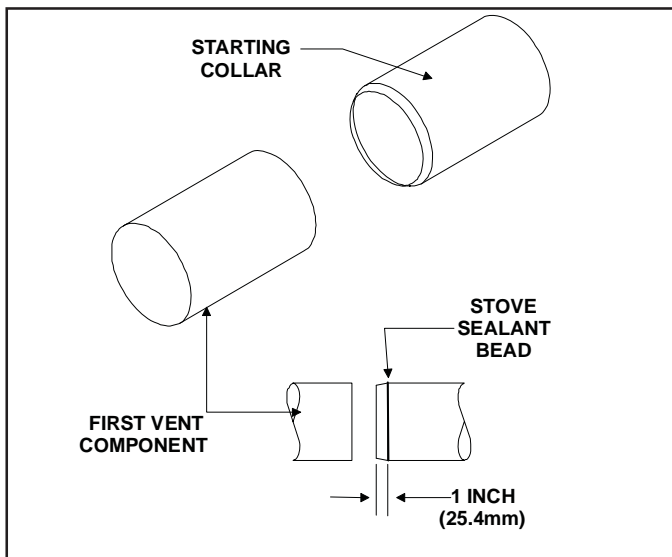

Figure 12. Attaching the First Vent Component to the Starting Collars

2. Continue Adding Vent Components

- Continue adding vent components, locking each succeeding component into place.
- Ensure that each succeeding vent component is securely fitted and locked into the preceding component in the vent system.
- 90° elbows may be installed and rotated to any point around the preceding component's vertical axis. If an elbow does not end up in a locked position with the preceding component, attach with a minimum of two (2) sheet metal screws.

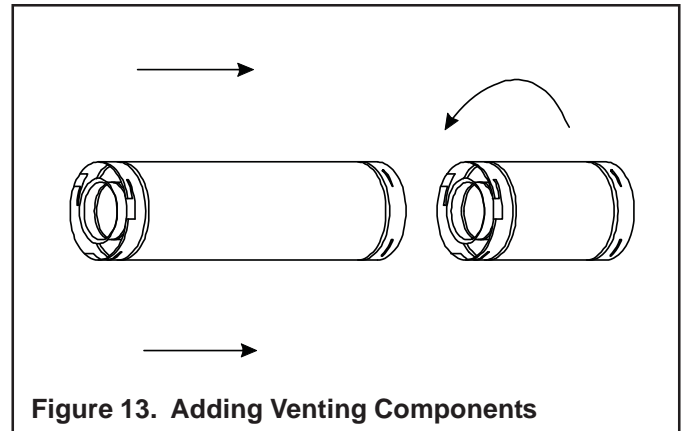

Figure 13. Adding Venting Components

3. Install Support Brackets

For Horizontal Runs - The vent system must be supported every five (5) feet of horizontal run by a horizontal pipe support.

To install support brackets for horizontal runs:

- Place the pipe supports around the vent pipe.
- Nail the pipe supports to the framing members.

WARNING: A 3/8 INCH (9.5 MM) BEAD OF STOVE CEMENT MUST BE PLACED AROUND THE FIREPLACE INNER VENT STARTING COLLAR BEFORE ATTACHING THE FIRST VENT COMPONENT. FAILURE TO SEAL THIS JOINT MAY CAUSE THE FIREPLACE TO OPERATE IMPROPERLY. SEE THE DIAGRAM .

WARNING: ENSURE THAT THE FIBER-GLASS ROPE GASKET SUPPLIED WITH THE FIREPLACE SEALS BETWEEN THE FIRST VENT COMPONENT AND THE OUTER FIREPLACE WRAP.

If the installation is for a termination cap attached directly to the fireplace, skip to the sections, **Install Firestops and Vent Termination**.

For Vertical Runs - The vent system must be supported every eight (8) feet (2.4m) above the fireplace flue outlet by wall brackets.

To install support brackets for vertical runs:

- Attach wall brackets to the vent pipe and secure the wall bracket to the framing members with nails or screws.

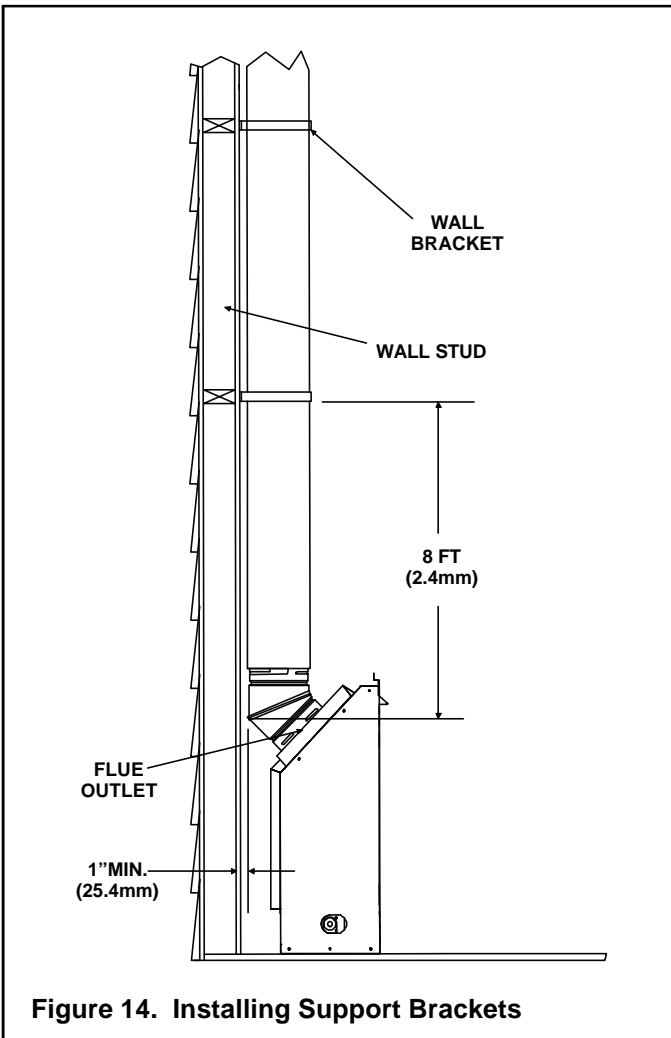

Figure 14. Installing Support Brackets

4. Install Firestops

For Horizontal Runs - Firestops are **REQUIRED** on both sides of a combustible wall through which the vent passes.

NOTE: Model SLK-01TRD does not need an exterior firestop on an exterior combustible wall.

To install firestops for horizontal runs that pass through either interior or exterior walls:

- Cut a 10-inch by 10-inch (254mm X 254mm) hole for SL-D series pipe.

NOTE: The center of the hole is one (1) inch (25.4mm) above the center of the horizontal vent pipe.

- Position the firestops on both sides of the hole previously cut and secure the firestops with nails or screws.
- The heat shields of the firestops **MUST BE** placed towards the top of the hole.
- Continue the vent run through the firestops.

NOTE: There must be NO INSULATION or other combustibles inside the framed firestop opening.

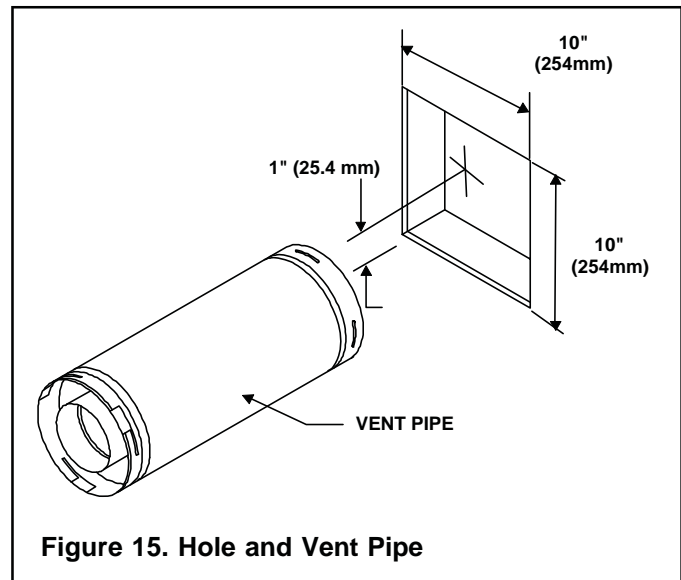

Figure 15. Hole and Vent Pipe

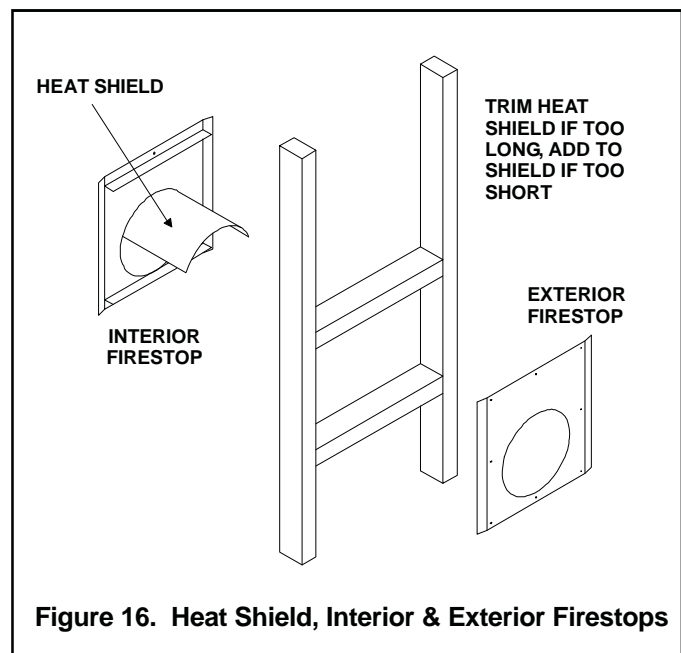

Figure 16. Heat Shield, Interior & Exterior Firestops

For Vertical Runs - One ceiling firestop is **REQUIRED** at the hole in each ceiling through which the vent passes.

To install firestops for vertical runs that pass through ceilings:

- Position a plumb bob directly over the center of the vertical vent component.
- Mark the ceiling to establish the centerpoint of the vent.
- Drill a hole or drive a nail through this centerpoint.
- Check the floor above for any obstructions, such as wiring or plumbing runs.
- Reposition the fireplace and vent system, if necessary, to accommodate the ceiling joists and/or obstructions.
- Cut an 10-inch X 10-inch (254mm X 254mm) hole through the ceiling, using the centerpoint previously marked.
- Frame the hole with framing lumber the same size as the ceiling joists.

NOTE: There must be NO INSULATION or other combustibles inside the framed firestop opening.

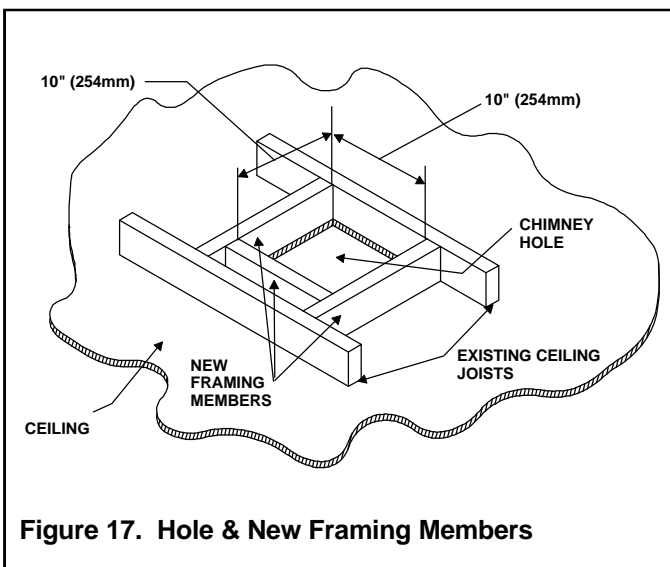

Figure 17. Hole & New Framing Members

If the area above the ceiling is **NOT** an attic, position and secure the ceiling firestop on the ceiling side of the previously cut and framed hole.

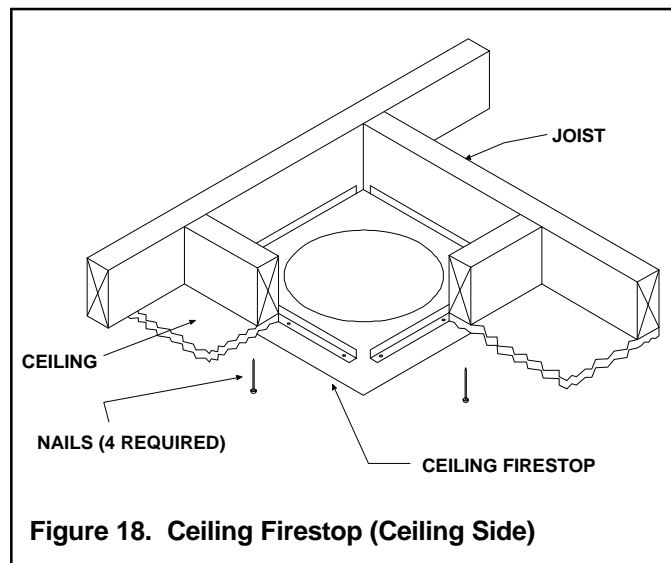

Figure 18. Ceiling Firestop (Ceiling Side)

If the area above the ceiling **IS** an attic, position and secure the firestop on top of the previously framed hole.

NOTE: Keep insulation away from the vent pipe at least 1 inch (25mm).

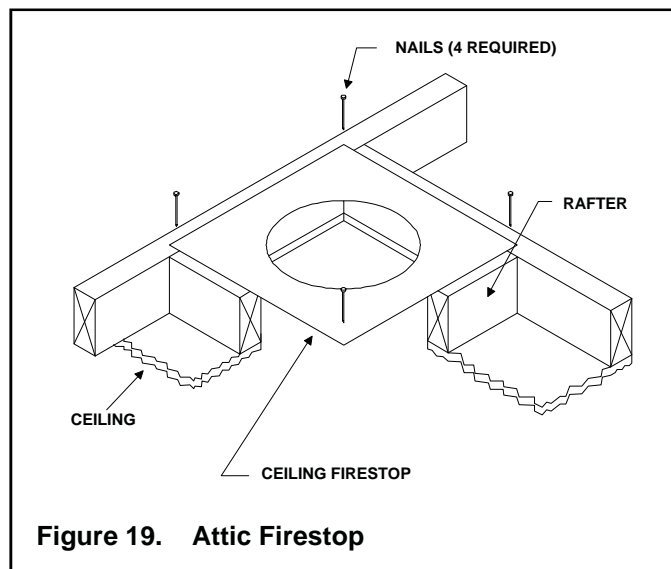

Figure 19. Attic Firestop

C. Vent Termination

For Horizontal Terminations - To attach and secure the termination to the last section of horizontal vent:

- Rotate and interlock the ends as described at the beginning of the Installing Vent Components section.
- The termination kit should pass through the wall firestops from the exterior of the building.
- Adjust the termination cap to its final exterior position on the building.



WARNING: THE TERMINATION CAP MUST BE POSITIONED SO THAT THE ARROW IS POINTING UP.

For roundcap termination kits:

- Use the exterior pipelock hole on the round flange of the wall firestop to secure the vent pipe in place.

For trapezoidal cap termination kits:

- Using screws secure the cap to the exterior wall through the flanges in the cap.



WARNING: THE BOTTOM OF THE VENT TERMINATION CAP MUST BE A MINIMUM OF 12 INCHES (305 MM) ABOVE GROUND LEVEL (GRADE). THE TOP OF THE CAP MUST BE A MINIMUM OF 18 INCHES (457 MM) BELOW COMBUSTIBLE MATERIAL, SUCH AS A DECK. THE SIDE OF THE CAP MUST BE A MINIMUM OF 6 INCHES (152 MM) AWAY FROM A PARALLEL OUTSIDE WALL. VENTING TERMINALS SHALL NOT BE RECESSED INTO A WALL OR SIDING. SEE THE FOLLOWING DIAGRAM FOR VENT TERMINATION CLEARANCES.

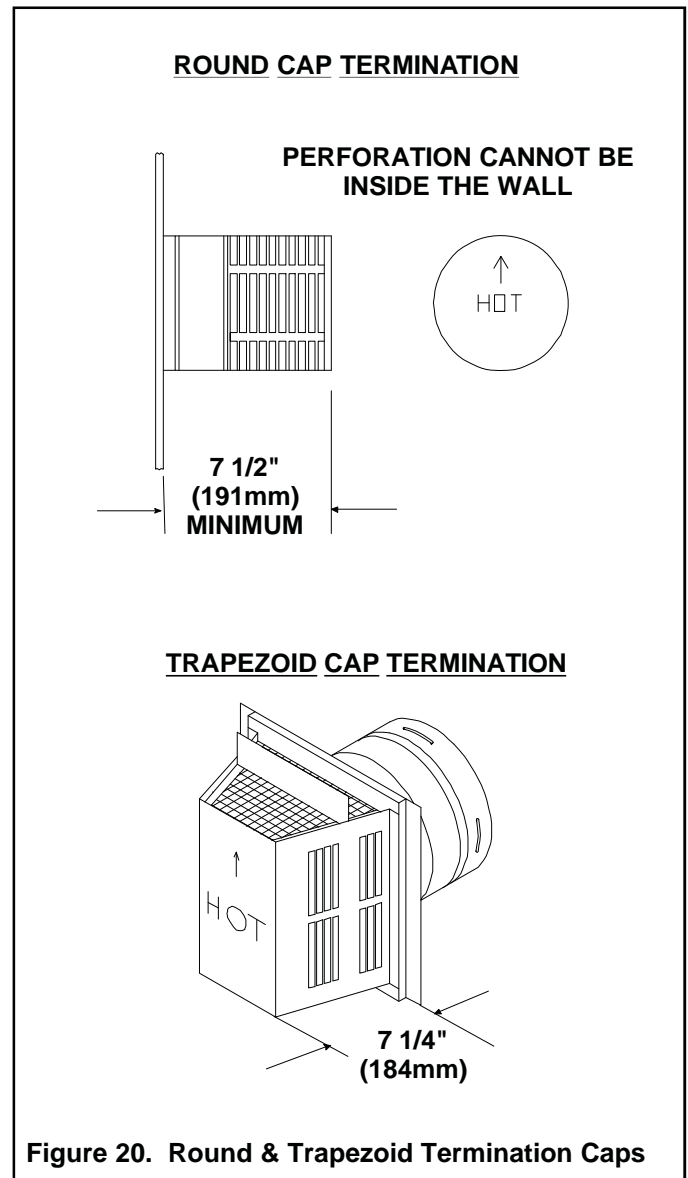
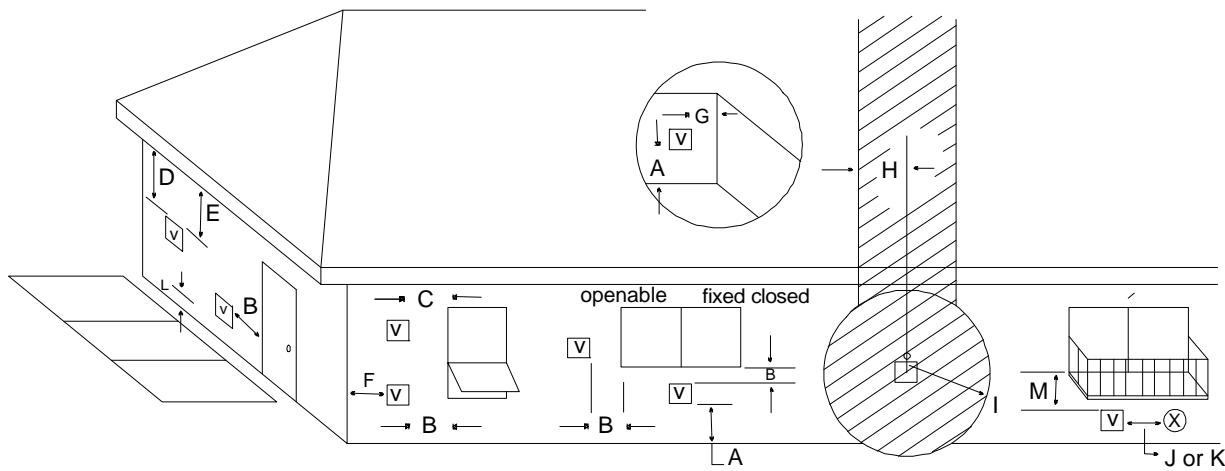

Figure 20. Round & Trapezoid Termination Caps



V = VENT TERMINAL **X** = AIR SUPPLY INLET = AREA WHERE TERMINAL IS NOT PERMITTED

- A = 12" clearances above grade, veranda, porch, deck or balcony
- B = 12" clearances to window or door that may be opened
- C = 9" (U.S.A.)
12" (Canada) clearance to permanently closed window.
- *D = 18" vertical clearance to ventilated soffit located above the terminal within a horizontal distance of 2 feet (60 cm) from the center-line of the terminal
- *E = 18" clearance to unventilated soffit
- F = 9" clearance to outside corner
- G = 6" clearance to inside corner
- H = 3 ft. (Canada) not to be installed above a gas meter/regulator assembly within 3 feet (90cm) horizontally from the center-line of the regulator

- I = 3 ft. (U.S.A.)
6 ft. (Canada) clearance to service regulator vent outlet.
- J = 9" (U.S.A.)
12" (Canada) clearance to non-mechanical air supply inlet to building or the combustion air inlet to any other appliance
- K = 3 ft. (U.S.A.)
6 ft. (Canada) clearance to a mechanical air supply inlet
- **L = 7 ft. clearance above paved sidewalk or a paved driveway located on public property
- ***M = 18" clearance under veranda, porch, deck or balcony

*** 30" minimum for vinyl clad soffits.**

** a vent shall not terminate directly above a sidewalk or paved driveway which is located between two single family dwellings and serves both dwellings.

*** only permitted if veranda, porch, deck or balcony is fully open on a minimum of 2 sides beneath the floor.

NOTE: Local codes or regulations may require different clearances.

Figure 21. Vent Termination Minimum Clearances

CAUTION: IF EXTERIOR WALLS ARE FINISHED WITH VINYL SIDING, IT IS NECESSARY TO INSTALL THE VINYL PROTECTOR KIT TO THE TOP OF THE EXTERIOR FIRESTOP (FOR ALL ROUND TERMINATION CAPS).

For Vertical Terminations - To locate the vent and install the vent sections:

- Locate and mark the vent centerpoint on the underside of the roof, and drive a nail through the centerpoint.
- Make the outline of the roof hole around the centerpoint nail.
- The size of the roof hole framing dimensions depend on the pitch of the roof. There **MUST BE** a 1-inch (25.4mm) clearance from the vertical vent pipe to combustible materials.
- Mark the roof hole accordingly.
- Cover the opening of the installed vent pipes.
- Cut and frame the roof hole.
- Use framing lumber the same size as the roof rafters and install the frame securely. Flashing anchored to the frame must withstand heavy winds.
- Continue to install concentric vent sections up through the roof hole and up past the roof line until you reach the appropriate distance above the roof.

To seal the roof hole, and to divert rain and snow from the vent system:

- Attach a flashing to the roof using nails, and use a non-hardening mastic around the edges of the flashing base where it meets the roof.
- Attach a storm collar over the flashing joint to form a water-tight seal. Place non-hardening mastic around the joint, between the storm collar and the vertical pipe.
- Slide the termination cap over the end of the vent pipe and rotate the pipe clockwise 1/4 turn.

WARNING: MAJOR U.S. BUILDING CODES SPECIFY MINIMUM CHIMNEY AND/OR VENT HEIGHT ABOVE THE ROOF TOP. THESE MINIMUM HEIGHTS ARE NECESSARY IN THE INTEREST OF SAFETY. SEE THE FOLLOWING DIAGRAM FOR MINIMUM HEIGHTS, PROVIDED THE TERMINATION CAP IS AT LEAST TWO (2) FEET FROM A VERTICAL WALL AND 2-FEET BELOW A HORIZONTAL OVERHANG.

NOTE: This also pertains to vertical vent systems installed on the outside of the building.

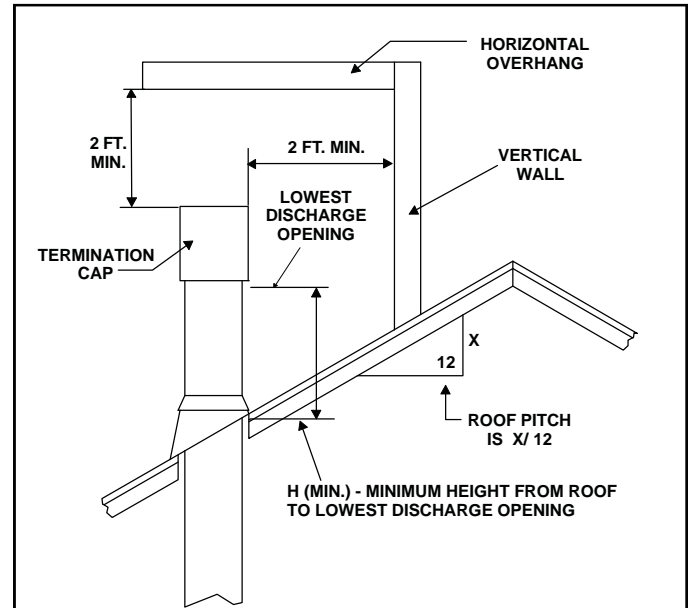

Roof Pitch	H (min.) ft.
flat to 6/12	1.0
6/12 to 7/12	1.25
over 7/12 to 8/12	1.5
over 8/12 to 9/12	2.0
over 9/12 to 10/12	2.5
over 10/12 to 11/12	3.25
over 11/12 to 12/12	4.0
over 12/12 to 14/12	5.0
over 14/12 to 16/12	6.0
over 16/12 to 18/12	7.0
over 18/12 to 20/12	7.5
over 20/12 to 21/12	8.0

Figure 22. Minimum Height from Roof to Lowest Discharge Opening

Step 4. Positioning, Leveling, and Securing the Fireplace

The diagram below shows how to properly position, level, and secure the fireplace.

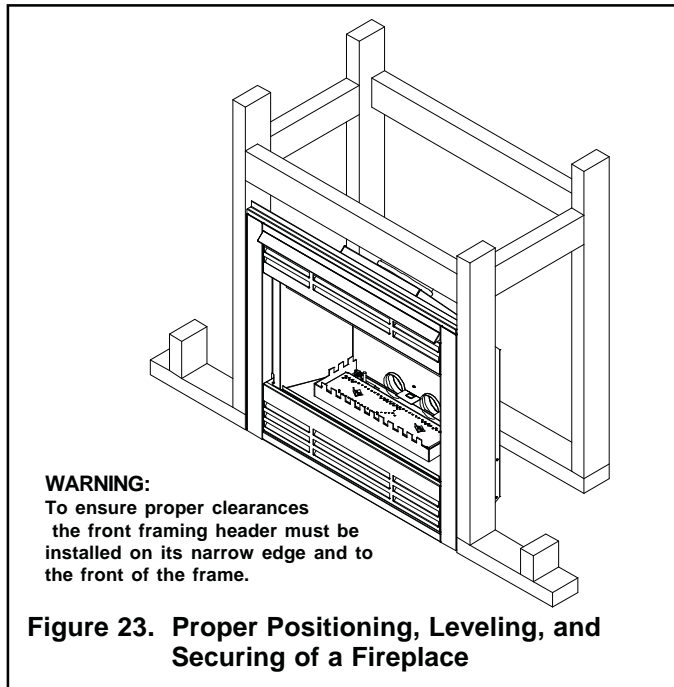

- Place the fireplace into position.
- Level the fireplace from side to side and from front to back.
- Shim the fireplace with non-combustible material, such as sheet metal, as necessary.
- Secure the fireplace to the framing by nailing or screwing.

Step 5. The Gas Control System



WARNING: THIS UNIT IS NOT FOR USE WITH SOLID FUEL.

The type of gas control system used with this model is Standing Pilot Ignition.

Standing Pilot Ignition System

This system includes millivolt control valve, standing pilot, thermopile/thermocouple flame sensor, and piezo ignitor.



WARNING: 110-120 VAC MUST NEVER BE CONNECTED TO A CONTROL VALVE IN A MILLIVOLT SYSTEM.

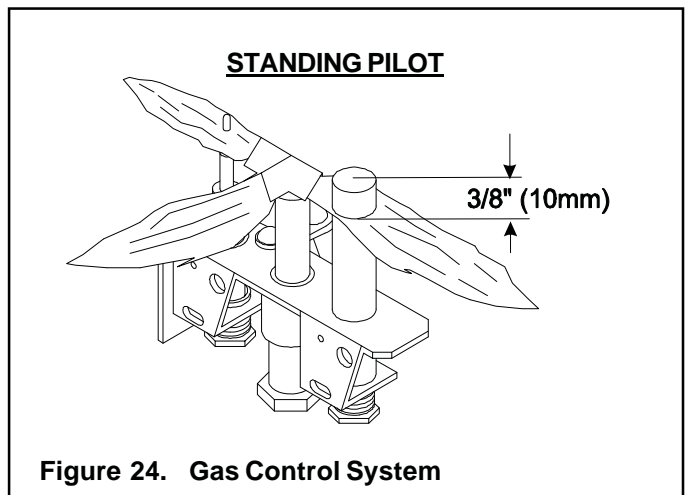

Step 6. The Gas Supply Line

NOTE: Have the gas supply line installed in accordance with local building codes by a qualified installer approved and/or licensed as required by the locality.

NOTE: Before the first firing of the fireplace, the gas supply line should be purged of any trapped air.

NOTE: Consult local building codes to properly size the gas supply line leading to the 1/2 inch (13 mm) hook-up at the unit.

This gas fireplace is designed to accept a 1/2 inch (13 mm) gas supply line. To install the gas supply line:

- A listed (and State of Massachusetts approved) 1/2 inch (13mm) tee-handle manual shut-off valve and a listed flexible gas connector are connected to the 1/2 inch (13mm) inlet of the control valve. **NOTE:** If substituting for these components, please consult local codes for compliance.
- Locate the gas line access hole in the outer casing of the fireplace.
- Open the fireplace lower grille, insert the gas supply line through the gas line hole, and connect it to the 3/8 inch (10mm) inlet of the gas valve.
- When attaching the pipe, support the control so that the lines are not bent or torn.
- After the gas line installation is complete, use a soap solution to carefully check all gas connections for leaks.



WARNING: DO NOT USE AN OPEN FLAME TO CHECK FOR GAS LEAKS.

- Insert insulation from the outside of the fireplace and pack the insulation tightly to totally seal between the pipe and the outer casing.
- At the gas line access hole the gap between the supply piping and gas access hole can be plugged with non-combustible insulation to prevent cold air infiltration.

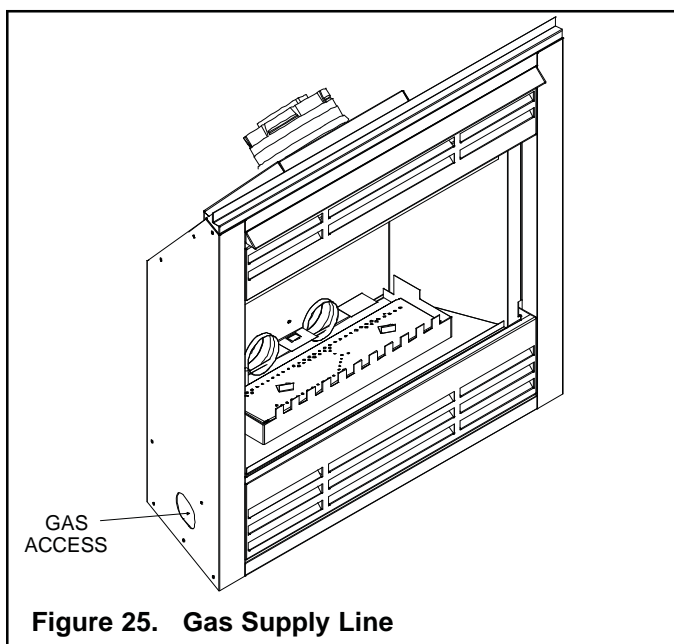

Figure 25. Gas Supply Line

Step 7. Gas Pressure Requirements

Pressure requirements for Heat-N-Glo gas fireplaces are shown in the table below.

Pressure	Natural Gas	Propane
Minimum Inlet Pressure	5.0 inches w.c.	11.0 inches w.c.
Maximum Inlet Gas Pressure	14.0 inches w.c.	14.0 inches w.c.
Manifold Pressure	3.5 inches w.c.	10.0 inches w.c.

A one-eighth (1/8) inch (3 mm) N.P.T. plugged tapping is provided on the inlet and outlet side of the gas control for a test gauge connection to measure the manifold pressure.

The fireplace and its individual shut-off valve must be disconnected from the gas supply piping system during any pressure testing of the system at test pressures in excess of one-half (1/2) psig (3.5 kPa).

The fireplace must be isolated from the gas supply piping system by closing its individual shut-off valve during any pressure testing of the gas supply piping system at test pressures equal to or less than one-half (1/2) psig (3.5 kPa).

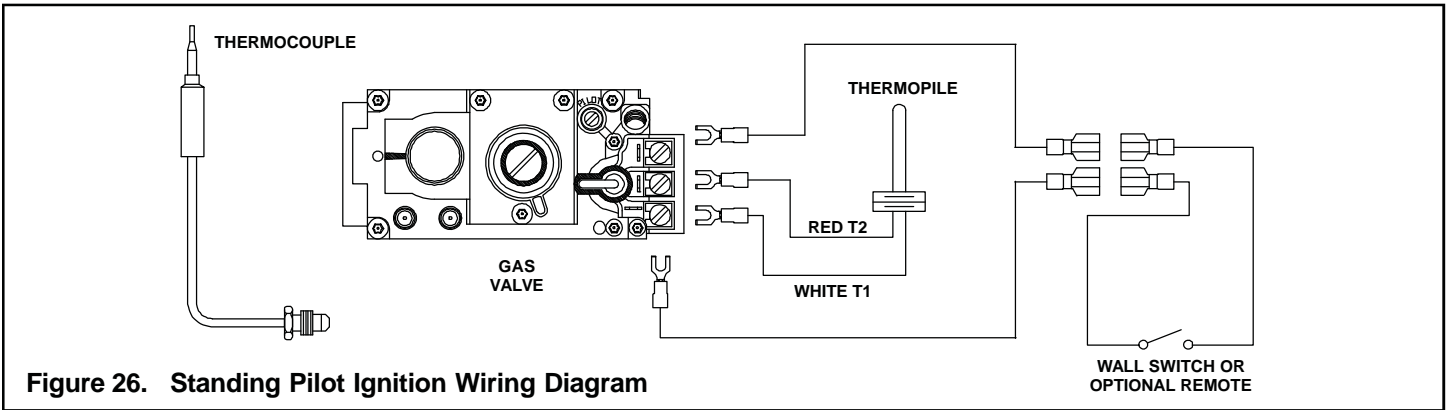

Figure 26. Standing Pilot Ignition Wiring Diagram

Step 8. Wiring the Fireplace

NOTE: Electrical wiring must be installed by a licensed electrician.

CAUTION: DISCONNECT REMOTE CONTROLS IF ABSENT FOR EXTENDED TIME PERIODS. THIS WILL PREVENT ACCIDENTAL FIREPLACE OPERATION.

For Standing Pilot Ignition Wiring

Appliance Requirements

- This appliance **DOES NOT** require 110-120 VAC to operate.

⚠ WARNING: DO NOT CONNECT 110-120 VAC TO THE GAS CONTROL VALVE OR WALL SWITCH OR THE APPLIANCE WILL MALFUNCTION AND THE VALVE WILL BE DESTROYED.

Optional Accessories

Optional fan and remote control kits require that 110-120 VAC be wired to the factory junction box before the fireplace is permanently installed.

Wall Switch

Position the wall switch in the desired position on a wall. Run a maximum of 25 feet (7.8 m) or less length of 18 A.W.G. minimum wire and connect it to the fireplace ON/OFF switch pigtails.

CAUTION: LABEL ALL WIRES PRIOR TO DISCONNECTION WHEN SERVICING CONTROLS. WIRING ERRORS CAN CAUSE IMPROPER AND DANGEROUS OPERATION. VERIFY PROPER OPERATION AFTER SERVICING.

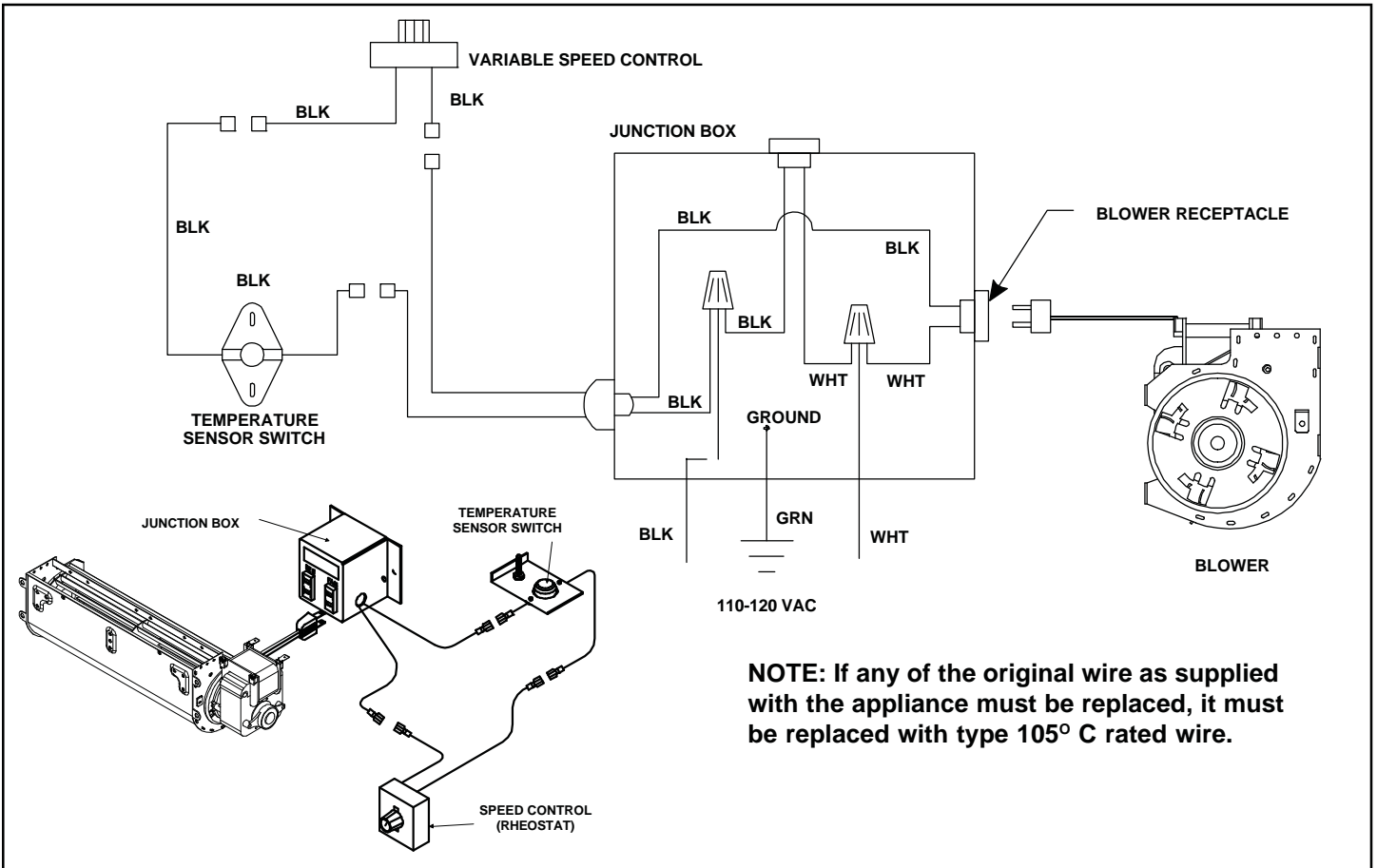

NOTE: If any of the original wire as supplied with the appliance must be replaced, it must be replaced with type 105° C rated wire.

Figure 27. Fan Wiring Diagram

Step 9. Finishing

Figure 28 shows the minimum vertical and corresponding maximum horizontal dimensions of fireplace mantels or other combustible projections above the top front edge of the fireplace. See Figures 2 and 3 for other fireplace clearances.

Only non-combustible materials may be used to cover the black fireplace front.



WARNING: WHEN FINISHING THE FIREPLACE, NEVER OBSTRUCT OR MODIFY THE AIR INLET/OUTLET GRILLES IN ANY MANNER.

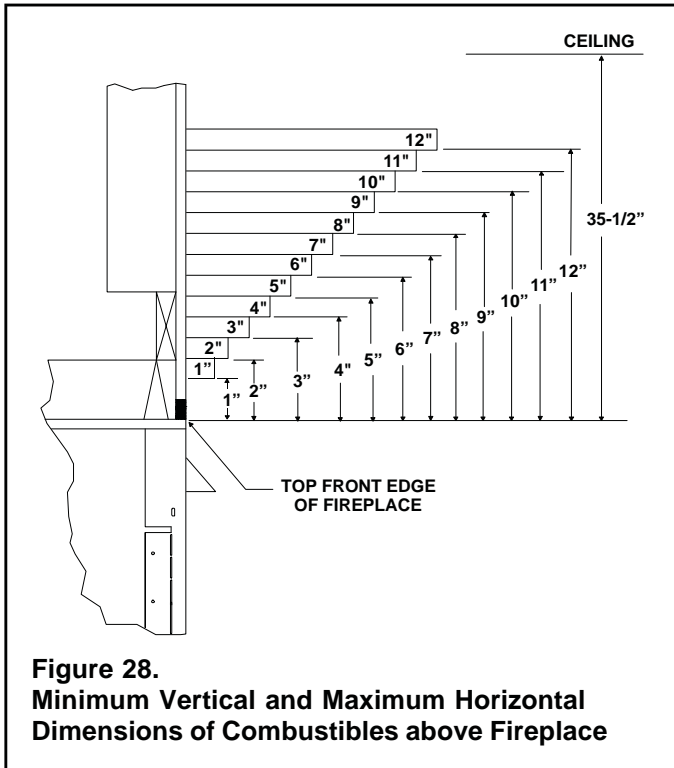

CAUTION: IF JOINTS BETWEEN THE FINISHED WALLS AND THE FIREPLACE SURROUND (TOP AND SIDES) ARE SEALED, A 300° F. MINIMUM SEALANT MATERIAL MUST BE USED. THESE JOINTS ARE NOT REQUIRED TO BE SEALED. ONLY NON-COMBUSTIBLE MATERIAL (USING 300° F. MINIMUM ADHESIVE, IF NEEDED) CAN BE APPLIED AS FACING TO THE FIREPLACE SURROUND. SEE THE DIAGRAM BELOW.

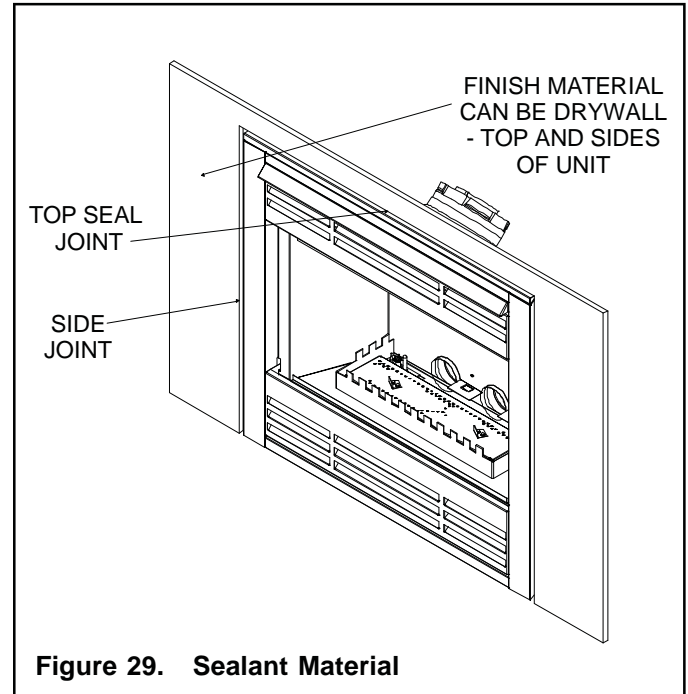

Hearth Extensions

A hearth extension may be desirable for aesthetic reasons. However, ANSI or CAN/CGA testing standards **do not** require hearth extensions for gas fireplace appliances.

Step 10. Installing Trim, Logs, and Ember Material

Installing the Trim

Combustible materials may be brought up to the specified clearances on the side and top front edges of the fireplace, but **MUST NEVER** overlap onto the front face. The joints between the finished wall and the fireplace top and sides can only be sealed with a 300° F. (149° C) minimum sealant.



WARNING: WHEN FINISHING THE FIREPLACE, NEVER OBSTRUCT OR MODIFY THE AIR INLET/OUTLET GRILLES IN ANY MANNER.

Install optional marble and brass trim surround kits as desired. Marble, brass, brick, tile, or other non-combustible materials can be used to cover up the gap between the sheet rock and the fireplace.

Do not obstruct or modify the air inlet/outlet grilles. When overlapping on both sides, leave enough space so that the bottom grille can be lowered and the trim door removed.

Placing the Ember Material and Vermiculite

To place the Glowing Ember (050-721) material:

1. Remove the top and bottom louvers by lifting them up and away from the unit.
2. Unlatch the latches at the top and bottom of the glass door.
3. Remove the glass door from the unit.
4. Cover the top of the burner (front ports only) with a single layer of ember material. The manufacturer recommends small amounts of ember material, if desired.
5. Pour the vermiculite onto the basepan surrounding the burner. The vermiculite must be located only outside of the log grate. Maximum thickness one inch high (see Figure 32).
6. Save the remaining vermiculite and ember materials for use during fireplace servicing. **Note:** Ensure vermiculite remains in the base pan only. Vermiculite must not contact any burner surfaces.
7. Reinstall and latch the glass door and louvers on the unit (See Replacement Parts Section of the manual.)

GLASS SPECIFICATIONS: 9 x 21-1/2 TEMPERED

Heat-N-Glo fireplaces manufactured with tempered glass may be installed in hazardous locations such as bathtub enclosures as defined by the CPSC. The tempered glass has been tested and certified to the requirements of ANSI Z97.1-1984 and CPSC 16 CFR 1202. (Safety Glazing Certification Council SGCC # 1595 and 1597. Architectural Testing, Inc. Reports 02-31919.01 and 02-31917.01.)

This statement is in compliance with SPCS 16 CFR Section 1201.5 "Certification and labeling requirements" which refers to 15 USC 2063 stating "...Such certificate shall accompany the product or shall otherwise be furnished to any distributor or retailer to whom the product is delivered."

Some local building codes require the use of tempered glass with permanent marking in such locations. Glass meeting this requirement is available from the factory. Please contact your dealer or distributor to order.

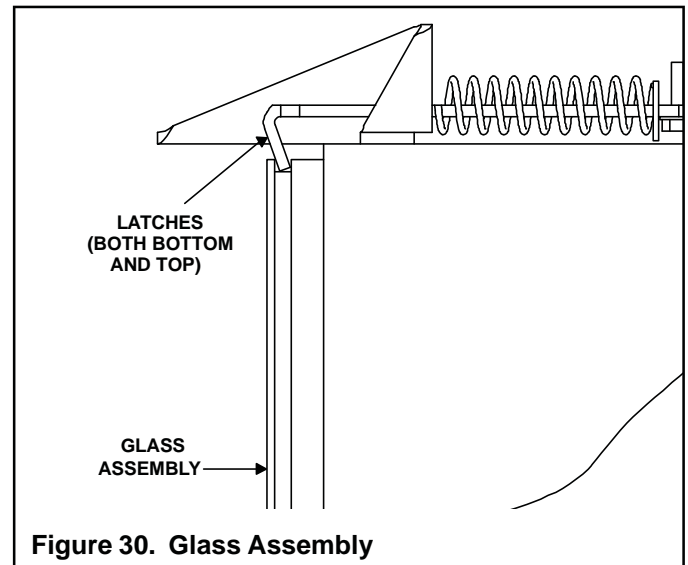

Figure 30. Glass Assembly

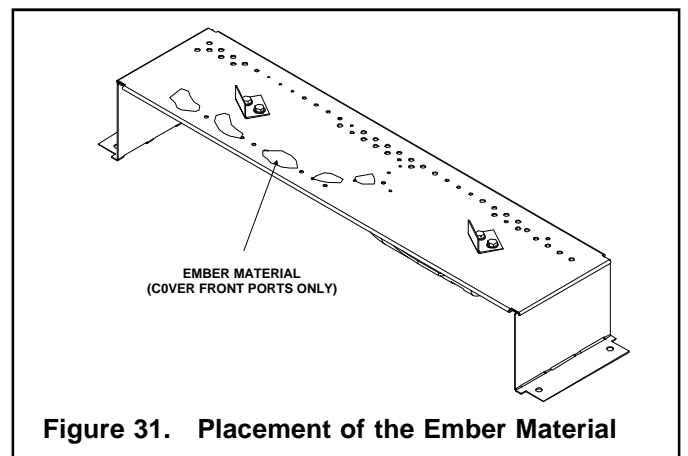

Figure 31. Placement of the Ember Material

CAUTION: IT IS STRONGLY RECOMMENDED THAT TRIM DOORS WITH OPTIONAL MESH SCREENS BE INSTALLED ON PROPANE MODELS.

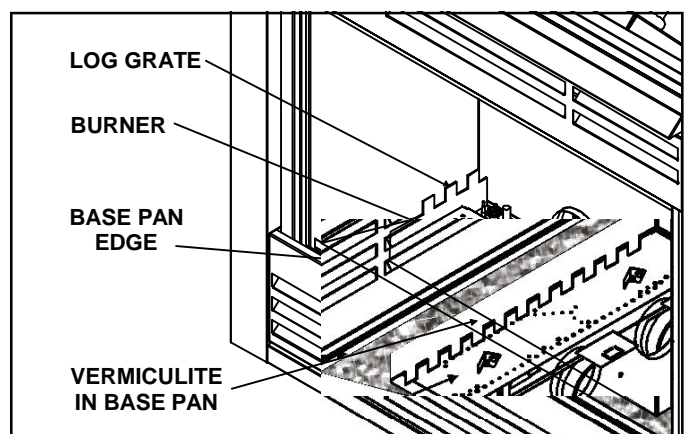

Figure 32. Placement of the Vermiculite

THE GLASS DOOR MUST BE SECURELY LATCHED BEFORE OPERATING THE UNIT.

Positioning the Logs

If sooting occurs, the logs might need to be repositioned slightly to avoid excessive flame impingement.

LOG PLACEMENT INSTRUCTIONS

CAUTION: Logs are fragile! Carefully remove the logs from the packaging.

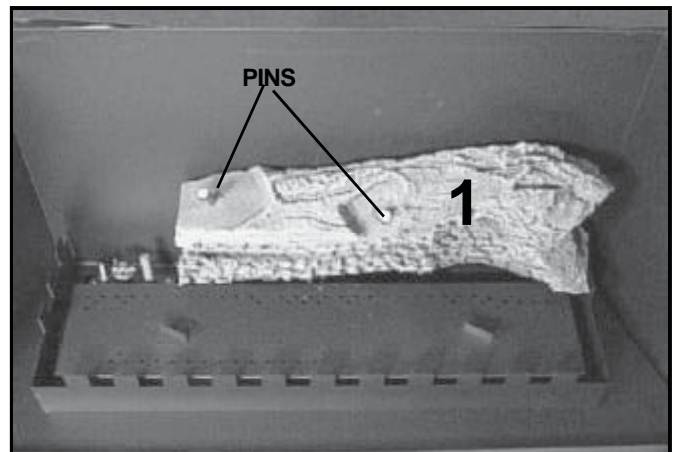
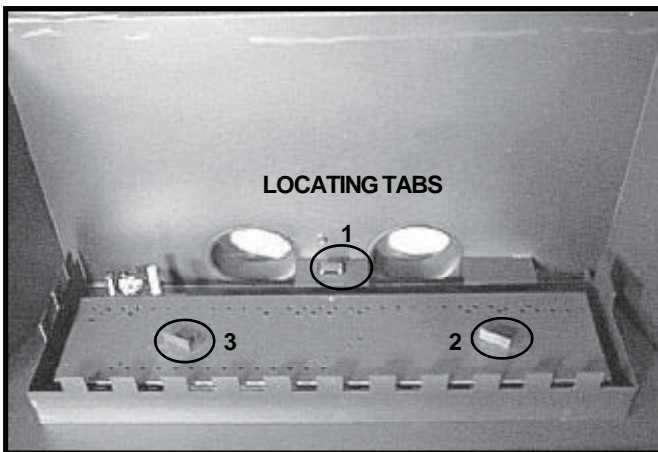
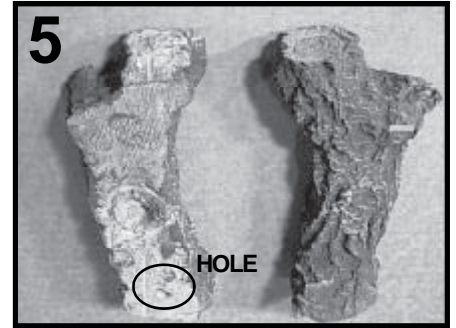
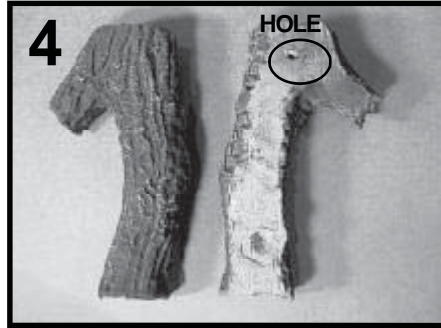
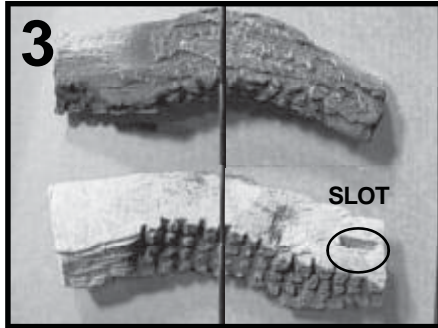
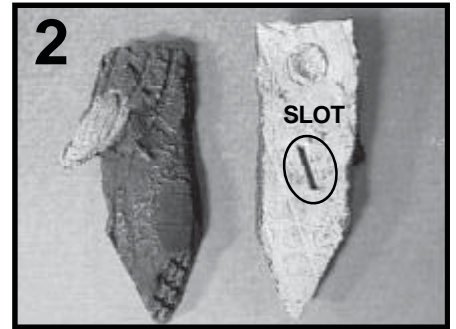

LOG NUMBER 1 (SRV589-701):

Place log number 1 against the rear wall of the heater, matching the slot in the bottom of the log to the metal tab on the bottom pan. Insert the 2 pins into the top holes in log #1. Pins supplied in manual bag.

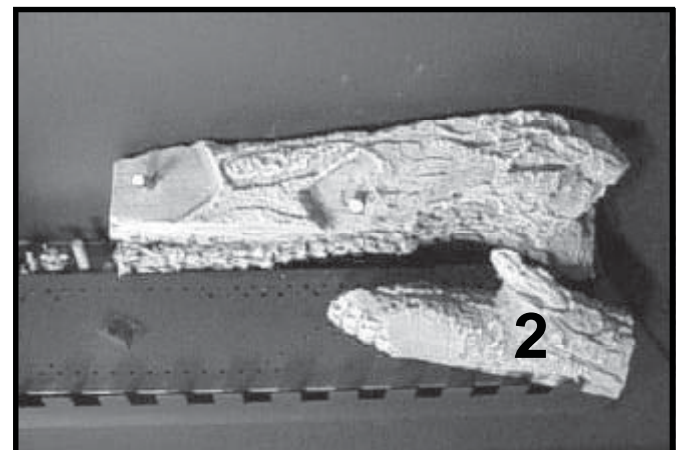
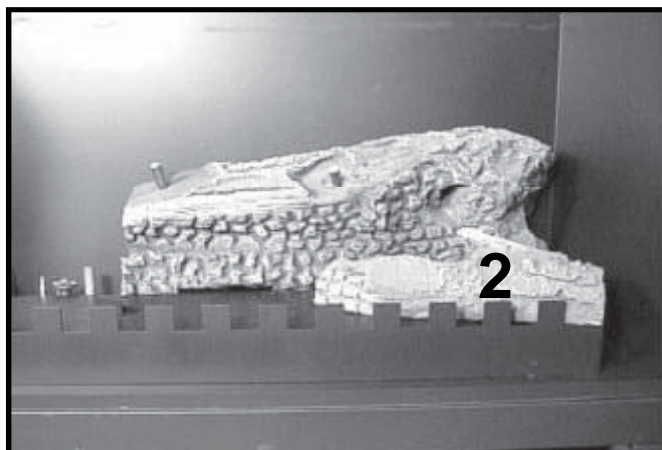

LOG NUMBER 2 (SRV589-703):

Place log number 2 onto the right side of the burner, aligning its slot with the tab protruding from the burner.

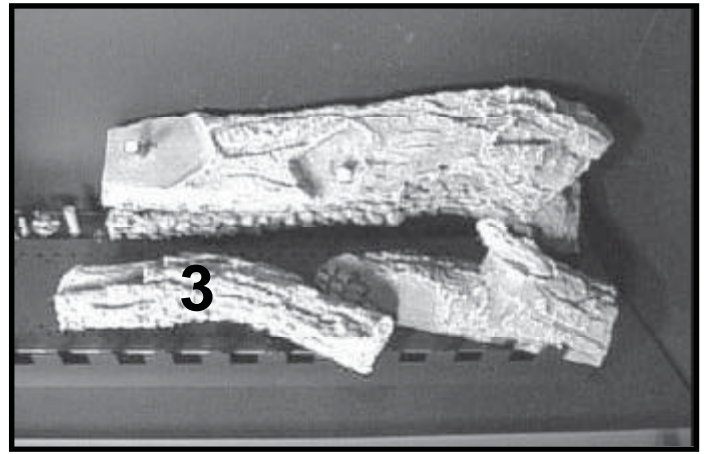
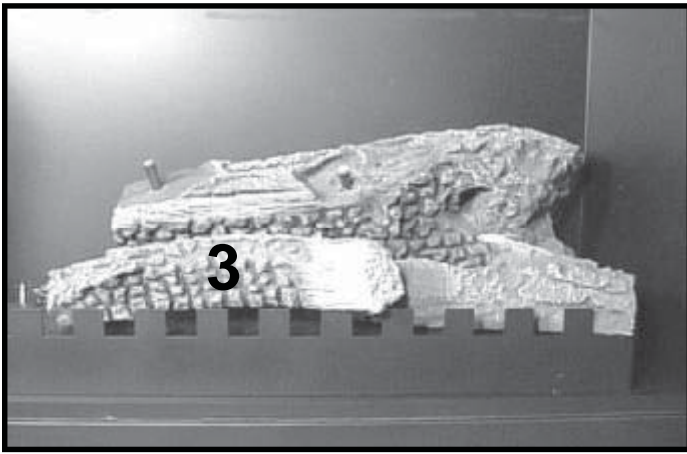

LOG NUMBER 3 (SRV589-702):

Position log number 3 on the left side of the burner, aligning its slot with the existing tab. The right hand side should rest between the 7th and 8th grate bars.

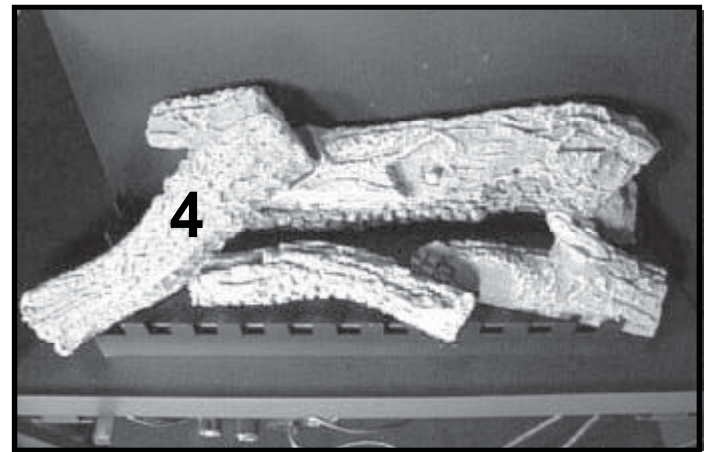
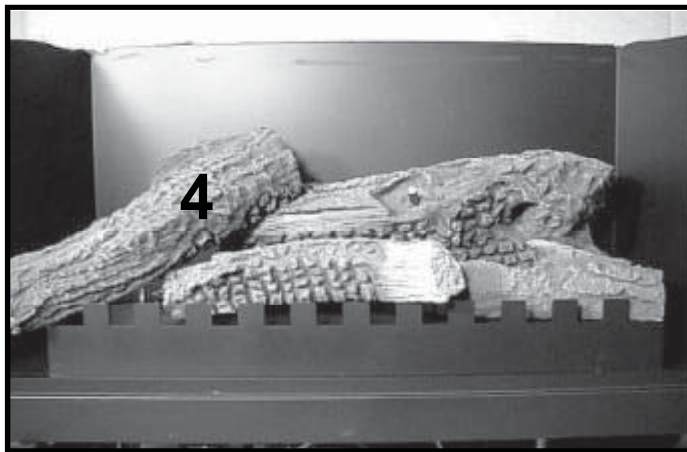

LOG NUMBER 4 (SRV589-704):

Position log number 4 so that its round hole fits over the protruding pin on the left side of log number 1.

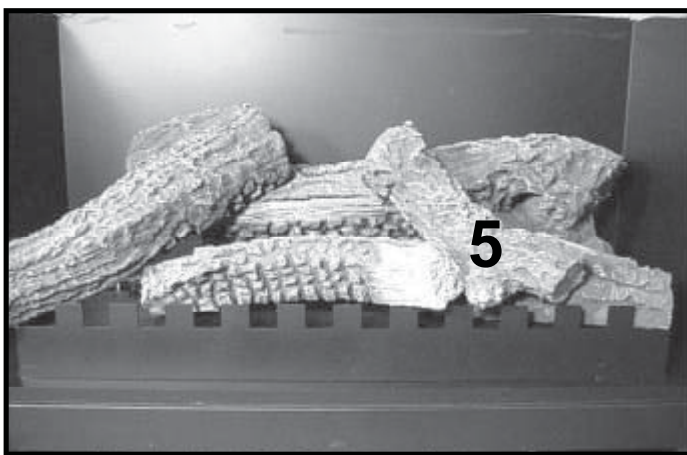

LOG NUMBER 5 (SRV589-705):

Put the forked end of log number 5 over the flat spot of log #2 and position so that its hole fits over the protruding pin on the right side of log #1.

Step 11. Before Lighting the Fireplace

Before lighting the fireplace, be sure to do the following:

Remove all paperwork from underneath the fireplace.

Review safety warnings and cautions

- Read the **Safety and Warning Information** section at the beginning of this *Installers Guide*.

Double-check for gas leaks

- Before lighting the fireplace, double-check the unit for possible gas leaks.

Double-check vent terminations and front grilles for obstructions.

- Before lighting the fireplace, double-check the unit for possible obstructions that could be blocking the vent terminations or the front grilles.

Double-check for faulty components

- Any component that is found to be faulty **MUST BE** replaced with an approved component. Tampering with the fireplace components is **DANGEROUS** and voids all warranties.

A small amount of air will be in the gas supply lines. When first lighting the fireplace, it will take a few minutes for the lines to purge themselves of this air. Once the purging is complete, the fireplace will light and will operate normally.

Subsequent lightings of the fireplace will not require this purging of air from the gas supply lines, **unless the gas valve has been turned to the OFF position**, in which case the air would have to be purged.

NOTE: The fireplace should be run 3 to 4 hours on the initial start-up. Turn it off and let it cool completely. Remove and clean the glass. Replace the glass and run the fireplace for an additional 8 hours. This will help to cure the chemicals used in the paint and logs.

Step 12. Lighting the Fireplace

You've reviewed all safety warnings, you've checked the fireplace for gas leaks, you know the vent system is unobstructed, and you've checked for faulty components. Now you're ready to light the fireplace.



WARNING: PLEASE REFER TO THE USER'S MANUAL FOR ALL CAUTIONS, SAFETY, AND WARNING INFORMATION PERTAINING TO THE LIGHTING AND OPERATION OF THE FIREPLACE.

After the Installation



LEAVE THIS INSTALLATION MANUAL WITH THE APPLIANCE FOR FUTURE REFERENCE.

4

Maintaining and Servicing Your Fireplace

Fireplace Maintenance

Although the frequency of your fireplace servicing and maintenance will depend on use and the type of installation, you should have a qualified service technician perform an appliance check-up at the beginning of each heating season. See the table below for specific guidelines regarding each fireplace maintenance task.

IMPORTANT: TURN OFF THE GAS BEFORE SERVICING YOUR FIREPLACE.

Replacing old ember material

Frequency: Once annually, during the checkup.

By: Qualified service technician.

Task: Brush away loose ember material near the burner. Replace old ember material with new dime-size and shape pieces of Golden Ember (GE-93) and Glowing Ember (050-721). New ember material should be placed alternately on top of the burner - a layer of Golden Ember, a layer of Glowing Ember, and so on. Save the remaining ember material and repeat this procedure at your next servicing. For more information, see **Placing Ember Material**.

Cleaning Burner and Controls

Frequency: Once annually.

By: Qualified service technician.

Task: Brush or vacuum the control compartment, fireplace logs, burner areas surrounding the logs and burner neck. Special attention should be given to the location of vermiculite. Ensure that it remains in the base pan and away from the burner neck and orifice.

Checking Flame Patterns, Flame Height

Frequency: Periodically.

By: Qualified service technician/Home owner.

Task: Make a visual check of your fireplace's flame patterns. Make sure the flames are steady - not lifting or floating. See Figure 33. The thermopile/thermocouple tips should be covered with flame. See Figure 24.

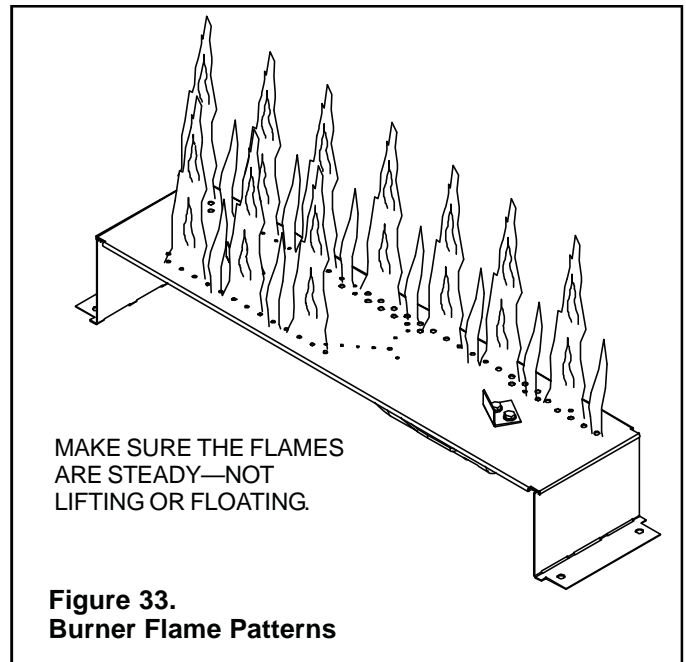

Checking Vent System

Frequency: Before initial use and at least annually thereafter, more frequently if possible.

By: Qualified service technician/Home owner.

Task: Inspect the external vent cap on a regular basis to ensure that no debris is interfering with the flow of air. Inspect entire vent system for proper function.

Cleaning Glass Door

Frequency: After the first 3 to 4 hours of use. As necessary after initial cleaning.

By: Home owner.

Task: Remove and clean glass after the first 3 to 4 hours of use. After the initial cleaning, clean as necessary, particularly after adding new ember (flame colorant) material. Film deposits on the inside of the glass door should be cleaned off using a household glass cleaner. **NOTE: DO NOT handle or attempt to clean the door when it is hot and DO NOT use abrasive cleaners.**

H

omeowner's Notes
