

Heat-N-Glo Fireplace

Model:
GRAND-50

Installers Guide



Underwriters
Laboratories Listed



This appliance has been retired.
Service parts pages within have been removed.
For replacement parts, please refer to the individual
service parts list located on the brand websites.

WARNING: IF THE INFORMATION IN THESE INSTRUCTIONS IS NOT FOLLOWED EXACTLY, A FIRE OR EXPLOSION MAY RESULT CAUSING PROPERTY DAMAGE, PERSONAL INJURY, OR DEATH.

- Do not store or use gasoline or other flammable vapors and liquids in the vicinity of this or any other appliance.
- **What to do if you smell gas**
 - Do not try to light any appliance.
 - Do not touch any electrical switch.
 - Do not use any phone in your building.
 - Immediately call your gas supplier from a neighbor's phone. Follow the gas supplier's instructions.
 - If you cannot reach your gas supplier, call the fire department.
- Installation and service must be performed by a qualified installer, service agency, or the gas supplier.

READ THIS MANUAL BEFORE INSTALLING OR OPERATING THIS APPLIANCE. THIS INSTALLERS GUIDE MUST BE LEFT WITH APPLIANCE FOR FUTURE REFERENCE.

WARNING: IMPROPER INSTALLATION, ADJUSTMENT, ALTERATION, SERVICE OR MAINTENANCE CAN CAUSE INJURY OR PROPERTY DAMAGE. REFER TO THIS MANUAL. FOR ASSISTANCE OR ADDITIONAL INFORMATION CONSULT A QUALIFIED INSTALLER, SERVICE AGENCY, OR THE GAS SUPPLIER.

1. This appliance may be installed in an aftermarket, permanently located, manufactured (mobile) home, where not prohibited by local codes.
2. This appliance is only for use with the type of gas indicated on the rating plate. This appliance is not convertible for use with other gases, unless a certified kit is used.

Printed in U.S.A. Copyright 1998,
Heat-N-Glo, a division of Hearth Technologies Inc.
6665 West Highway 13, Savage, MN 55378

Please contact your Heat-N-Glo dealer for any questions or concerns. For the number of your nearest Heat-N-Glo dealer, please call 612-890-8367.

This product is covered by one or more of the following patents: (United States) 4,112,913; 4,408,594; 4,422,426; 4,424,792; 4,520,791; 4,793,322; 4,852,548; 4,875,464; 5,000,162; 5,016,609; 5,076,254 5,191,877; 5,218,953; 5,328,356; 5,429,495; 5,452,708; 5,542,407; 5,613,487; (Australia) 543790; 586383; (Canada) 1,123,296; 1,297,746; 2,195,264; (Mexico) 97-0457; (New Zealand) 200265; or other U.S. and foreign patents pending.

SAFETY AND WARNING INFORMATION



READ and **UNDERSTAND** all instructions carefully before starting the installation. **FAILURE TO FOLLOW** these installation instructions may result in a possible fire hazard and will void the warranty.



Prior to the first firing of the fireplace, **READ** the Using Your Fireplace section of the *Owners Guide*.



DO NOT USE this appliance if any part has been under water. Immediately **CALL** a qualified service technician to inspect the unit and to replace any part of the control system and any gas control which has been underwater.



THIS UNIT IS NOT FOR USE WITH SOLID FUEL.



Installation and repair should be **PERFORMED** by a qualified service person. The appliance and venting system should be **INSPECTED** before initial use and at least annually by a professional service person. More frequent cleaning may be required due to excessive lint from carpeting, bedding material, etc. It is **IMPERATIVE** that the unit's control compartment, burners, and circulating air passageways **BE KEPT CLEAN** to provide for adequate combustion and ventilation air.



Always **KEEP** the appliance clear and free from combustible materials, gasoline, and other flammable vapors and liquids.



NEVER OBSTRUCT the flow of combustion and ventilation air. Keep the front of the appliance **CLEAR** of all obstacles and materials for servicing and proper operations.



Due to the high temperature, the appliance should be **LOCATED** out of traffic areas and away from furniture and draperies. Clothing or flammable material **SHOULD NOT BE PLACED** on or near the appliance.



Children and adults should be **ALERTED** to the hazards of high surface temperature and should **STAY AWAY** to avoid burns or clothing ignition. Young children should be **CAREFULLY SUPERVISED** when they are in the same room as the appliance.



These units **MUST** use one of the vent systems described in the Installing the Fireplace section of the *Installers Guide*. **NO OTHER** vent systems or components **MAY BE USED**.



This gas fireplace and vent assembly **MUST** be vented directly to the outside and **MUST NEVER** be attached to a chimney serving a separate solid fuel burning appliance. Each gas appliance **MUST USE** a separate vent system. Common vent systems are **PROHIBITED**.



INSPECT the external vent cap on a regular basis to make sure that no debris is interfering with the air flow.



The glass door assembly **MUST** be in place and sealed, and the trim door assembly **MUST** be in place on the fireplace before the unit can be placed into safe operation.



DO NOT OPERATE this appliance with the glass door removed, cracked, or broken. Replacement of the glass door should be performed by a licensed or qualified service person. **DO NOT** strike or slam the glass door.



The glass door assembly **SHALL ONLY** be replaced as a complete unit, as supplied by the gas fireplace manufacturer. **NO SUBSTITUTE** material may be used.



DO NOT USE abrasive cleaners on the glass door assembly. **DO NOT ATTEMPT** to clean the glass door when it is hot.



Turn off the gas before servicing this appliance. It is recommended that a qualified service technician perform an appliance check-up at the beginning of each heating season.



Any safety screen or guard removed for servicing must be replaced before operating this appliance.

Table of Contents

Safety and Warning Information	i
Section 1: Approvals and Codes	1
Approval Listings and Codes	1
Appliance Certification	1
Installation Codes	1
High Altitude Installations	1
Section 2: Getting Started	2
Introducing the Heat-N-Glo Gas Fireplaces	2
Pre-installation Preparation	2
Section 3: Installing the Fireplace	4
Step 1 Locating the Fireplace	4
Step 2 Framing the Fireplace	5
Step 3 Installing the Vent System	6
A. Vent System Approvals	6
B. Installing Vent Components	12
C. Vent Termination	17
Step 4 Positioning, Leveling, and Securing the Fireplace	22
Step 5 The Gas Control Systems	22
Step 6 The Gas Supply Line	23
Step 7 Gas Pressure Requirements	24
Step 8 Wiring the Fireplace	25
Step 9 Finishing	27
Step 10 Installing Trim, Logs and Ember Material	28
Installing the Trim	28
Positioning the Logs	29
Placing the Ember Material	29
Step 11 Before Lighting the Fireplace	31
Step 12 Lighting the Fireplace	31
After the Installation	31
Section 4: Maintenance and Servicing	32
Section 5: Replacement Parts and Accessories	34
Replacement Parts	35
Accessories	37

1

Approvals and Codes

Approval Listings and Codes

Appliance Certification

The Heat-N-Glo fireplace models discussed in this *Installers Guide* have been tested to certification standards and listed by the applicable laboratories.

MODEL	LABORATORY	TYPE	CERTIFICATION STANDARD
Grand 50	Underwriters Laboratories	Direct Vent Decorative	ANSI Z21.50 • CGA2.22

Installation Codes

The fireplace installation must conform to local codes. Before installing the fireplace, consult the local building code agency to ensure that you are in compliance with all applicable codes, including permits and inspections.

In the absence of local codes, the fireplace installation must conform to the National Fuel Gas Code ANSI Z223.1 (in the United States) or the CAN/CGA-B149 Installation Codes (in Canada). The appliance must be electrically grounded in accordance with local codes or, in the absence of local codes with the National Electric Code ANSI/NFPA No. 70 (in the United States), or to the CSA C22.1 Canadian Electric Code (in Canada).

These models may be installed in a bedroom or bed-sitting room in the U.S.A. and Canada.

High Altitude Installations

UL Listed gas fireplaces are tested and approved for elevations from 0 to 2,000 feet in the U.S.A., and from 0 to 4,500 feet in Canada.

When installing this fireplace at an elevation above 2,000 feet (in the United States), it may be necessary to decrease the input rating by changing the existing burner orifice to a smaller size. Input should be reduced four percent (4%) for each 1,000 feet above sea level, unless the heating value of the gas has been reduced, in which case this general rule will not apply. To identify the proper orifice size, check with the local gas utility.

When installing this fireplace at an elevation between 2,000 and 4,500 feet (in Canada), the input rating must be reduced by ten percent (10%).

When installing this fireplace at an elevation above 4,500 feet (in Canada), check with local authorities.

Consult your local gas utility for assistance in determining the proper orifice for your location.

Introducing the Heat-N-Glo Fireplaces

Heat-N-Glo direct vent gas fireplaces are designed to operate with all combustion air siphoned from outside of the building and all exhaust gases expelled to the outside.

The information contained in this *Installers Guide*, unless noted otherwise, applies to all models and gas control systems.

Gas fireplace diagrams, including the dimensions, are shown in this section.

Pre-installation Preparation

This gas fireplace and its components are tested and safe when installed in accordance with this *Installers Guide*. Report to your dealer any parts damaged in shipment, particularly the condition of the glass. **Do not install any unit with damaged, incomplete, or substitute parts.**

The vent system components are shipped in separate packages. The gas logs are packaged separately and must be field installed. **Read all of the instructions before starting the installation. Follow these instructions carefully during the installation to ensure maximum safety and benefit. Failure to follow these instructions will void the owner's warranty and may present a fire hazard.**

The Heat-N-Glo Warranty will be voided by, and Heat-N-Glo disclaims any responsibility for, the following actions:

- Installation of any damaged fireplace or vent system component.
- Modification of the fireplace or direct vent system.
- Installation other than as instructed by Heat-N-Glo.
- Improper positioning of the gas logs or the glass door.
- Installation and/or use of any component part not manufactured and approved by Heat-N-Glo, not withstanding any independent testing laboratory or other party approval of such component part or accessory.

ANY SUCH ACTION MAY POSSIBLY CAUSE A FIRE HAZARD.

2

Getting Started

When planning a fireplace installation, it's necessary to determine:

- Where the unit is to be installed.
- The vent system configuration to be used.
- Gas supply piping.
- Electrical wiring.
- Framing and finishing details.
- Whether optional accessories—devices such as a fan, wall switch, or remote control—are desired.

If the fireplace is to be installed on carpeting or tile, or on any combustible material other than wood flooring, the fireplace should be installed on a metal or wood panel that extends the full width and depth of the fireplace.

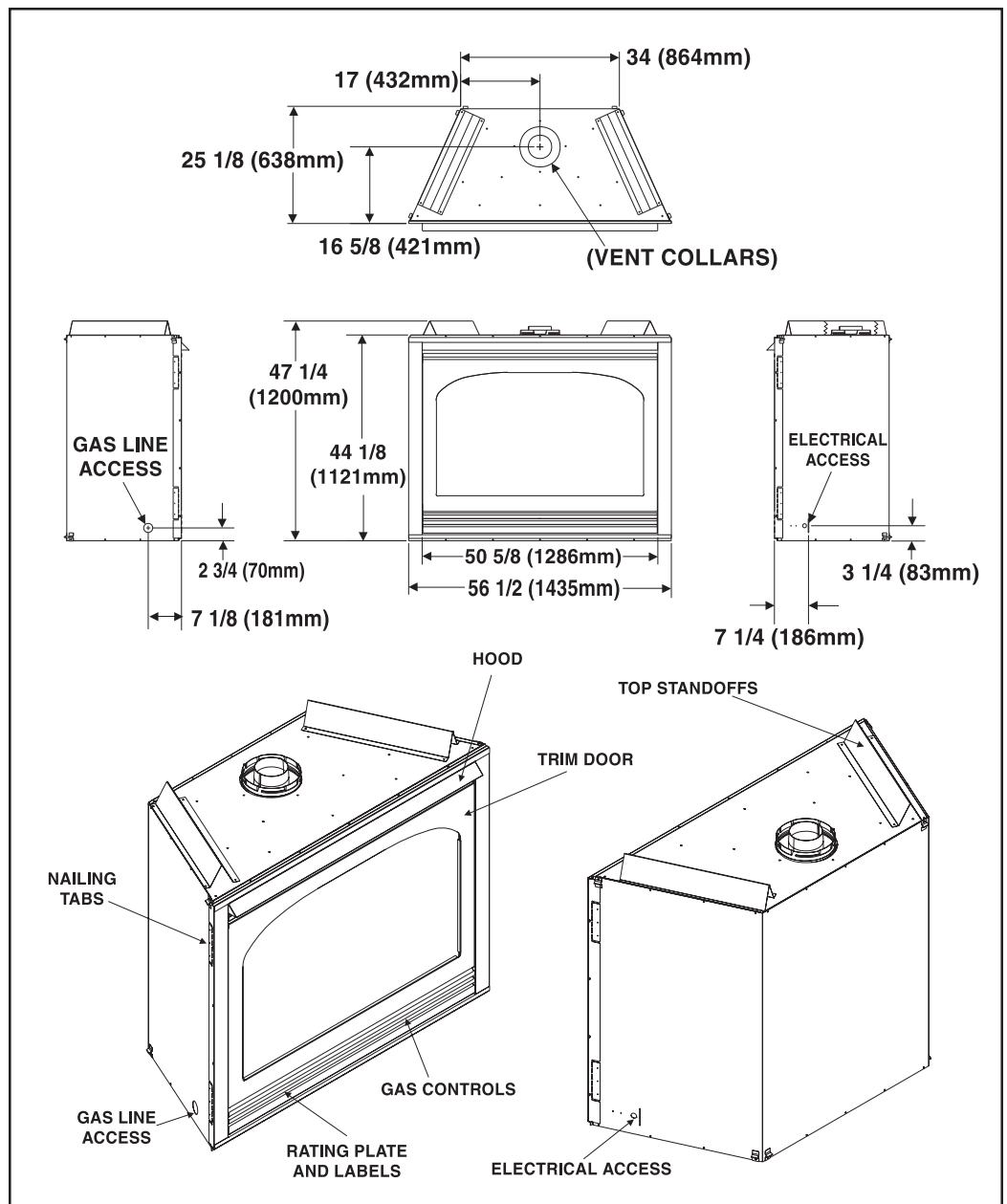

Figure 1. Diagram of the Grand-50

Step 1 Locating the Fireplace

The diagram below shows space and clearance requirements for locating a fireplace within a room.

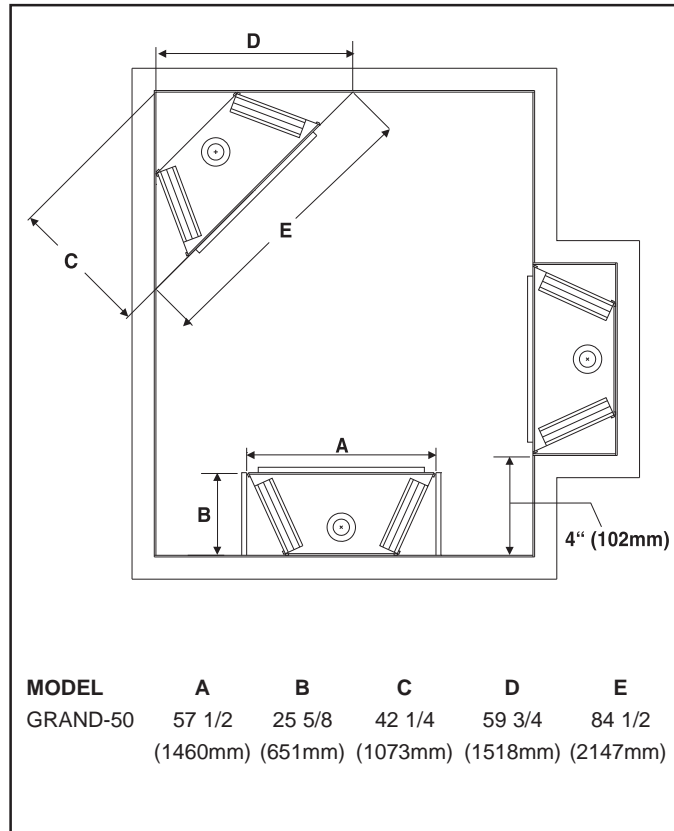

Figure 2. Fireplace Dimensions, Locations, and Space Requirements

Clearance Requirements

The top, back, and sides of the fireplace are defined by stand-offs.

Minimum Clearances from the Fireplace to Combustible Materials					
Glass Front	Floor	Rear of Fireplace	Sides of Fireplace	Top of Fireplace	Ceiling
36 inches (914 mm)	0	1/2 inch (13 mm)	1/2 inch (13 mm)	3-1/2 inches (89 mm)	31 inches (787 mm)

The minimum clearance to a perpendicular wall extending past the face of the fireplace is 4-inches (102 mm).

The back of the fireplace may be recessed 25 1/8 inches (638mm) into combustible construction.

3

Installing the Fireplace

Minimum Clearances from the Vent Pipe to Combustible Materials						
For Horizontal Sections			For Vertical Sections	At Wall Firestops		
Top	Bottom	Sides	1 inch (25 mm)	Top	Bottom	Sides
3 inches* (75 mm)	1 inch (25 mm)	1 inch (25 mm)			2-1/2 inches (63.7 mm)	1/2 inch (13 mm)

For minimum clearances, see the direct vent termination clearance diagrams on pages 19 and 21 in this section.

* Additional clearance and/or installation of a heat shield is required above the first 90° elbow. See page 13 of the Installers Guide.

Step 2 Framing the Fireplace

Fireplace framing can be built before or after the fireplace is set in place. Framing should be positioned to accommodate wall coverings and fireplace facing material. The diagram below shows framing reference dimensions.

CAUTION

MEASURE FIREPLACE DIMENSIONS, AND VERIFY FRAMING METHODS AND WALL COVERING DETAILS, BEFORE FRAMING CONSTRUCTION BEGINS.

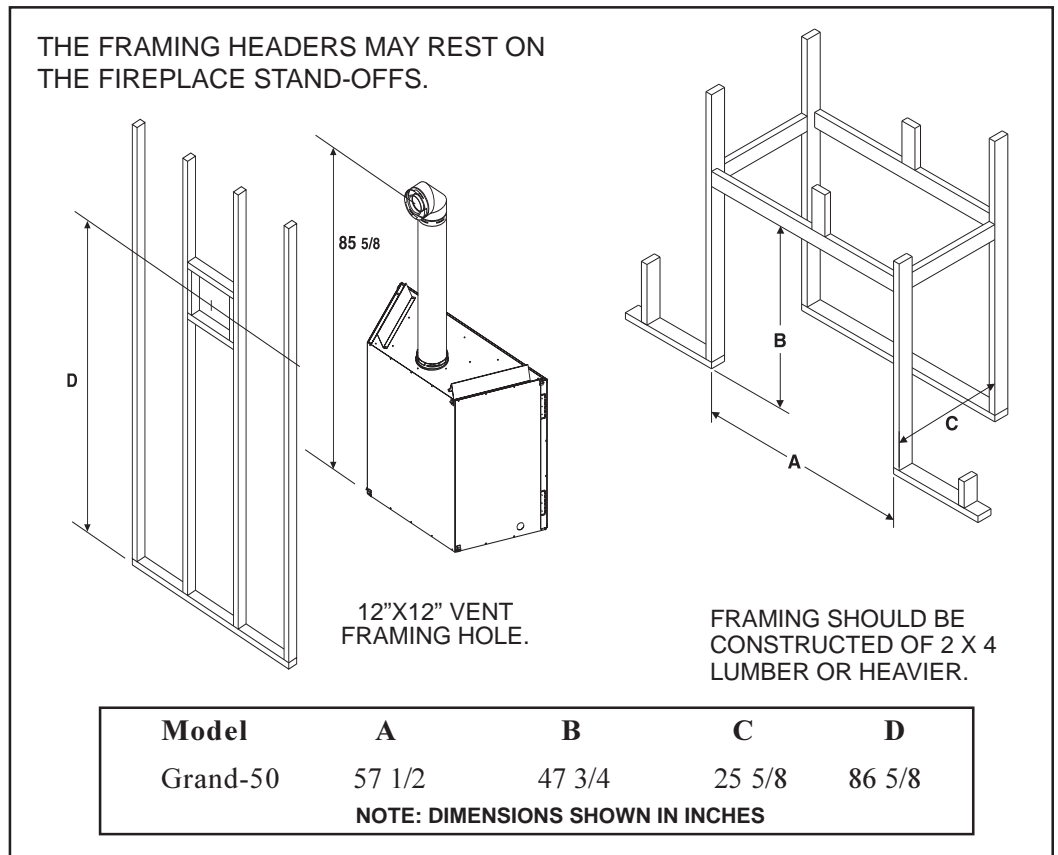

Figure 3. Framing Dimensions

Step 3 Installing the Vent System

A. Vent System Approvals

This model is approved to use D-Series components and terminations. Approved vent system components are labeled for identification. **NO OTHER VENTING SYSTEM OR COMPONENTS MAY BE USED.** Detailed installation instructions are included with each vent termination kit and should be used in conjunction with this *Installers Guide*. The drawing below shows vent system components and terminations.

The flame and ember appearance may vary based on the type of fuel burned and the venting configuration used.

Identifying Vent Components

The vent systems installed on this gas fireplace may include one, two, or three 90° elbow assemblies. The relationships of vertical rise to horizontal run in vent configurations using 90° elbows **MUST BE** strictly adhered to. The rise to run relationship are shown in the venting drawings and tables. Refer to the diagrams on the next several pages.



WARNING: A 3-FOOT LENGTH OF STRAIGHT PIPE (MINIMUM) MUST BE THE FIRST VENT COMPONENT ATTACHED TO THE UNIT.

NOTE: TWO 45° ELBOWS MAY BE USED IN PLACE OF ONE 90° ELBOW. RISE TO RUN RATIOS IN THE VENT SYSTEM MUST BE FOLLOWED IF 45° ELBOWS ARE USED.

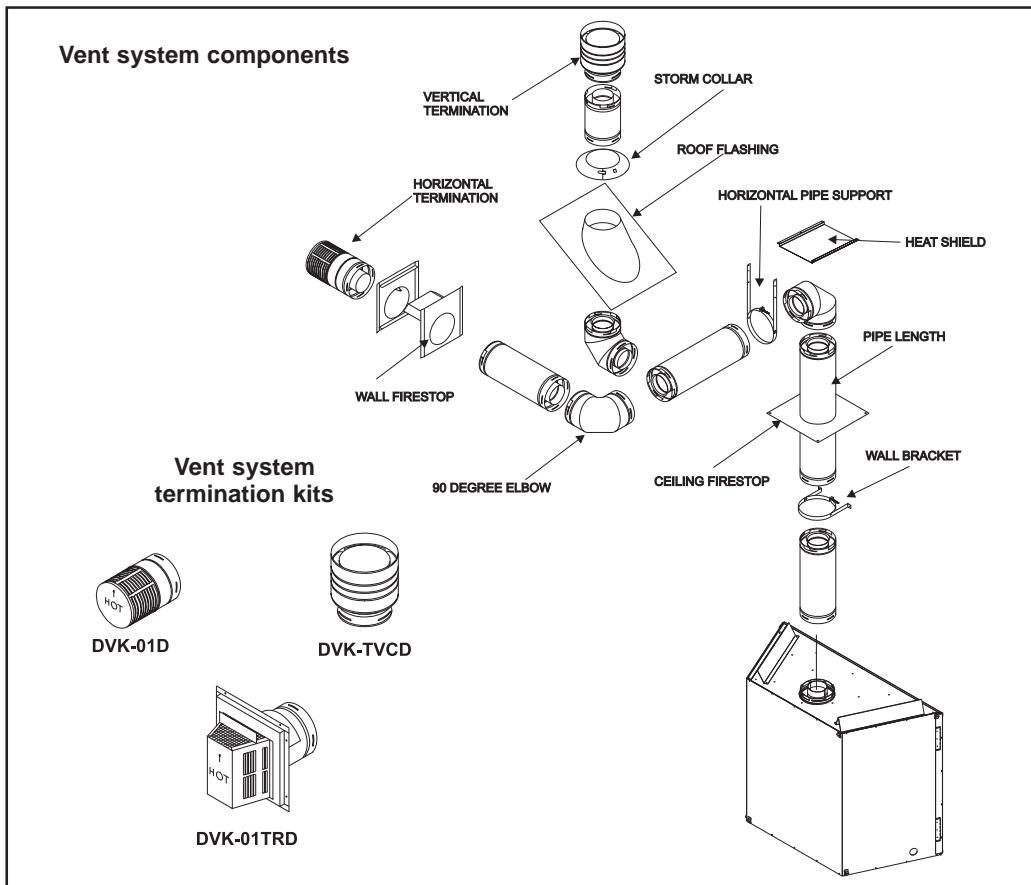

Figure 4. Vent Components and Terminations

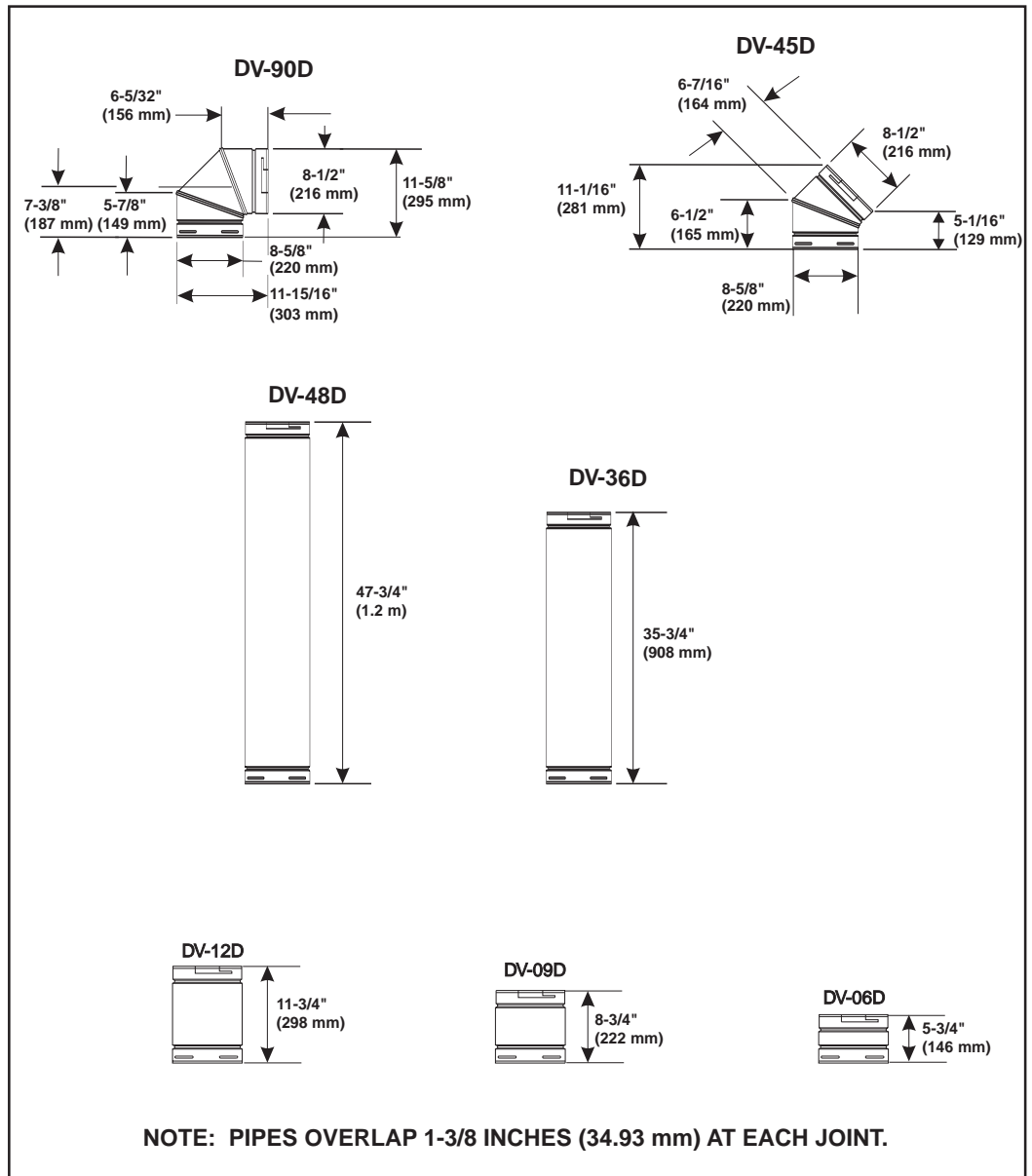

Figure 5. D-Series Direct Vent Component Specifications
(5-inch inner pipe/8 5/8-inch outer pipe)

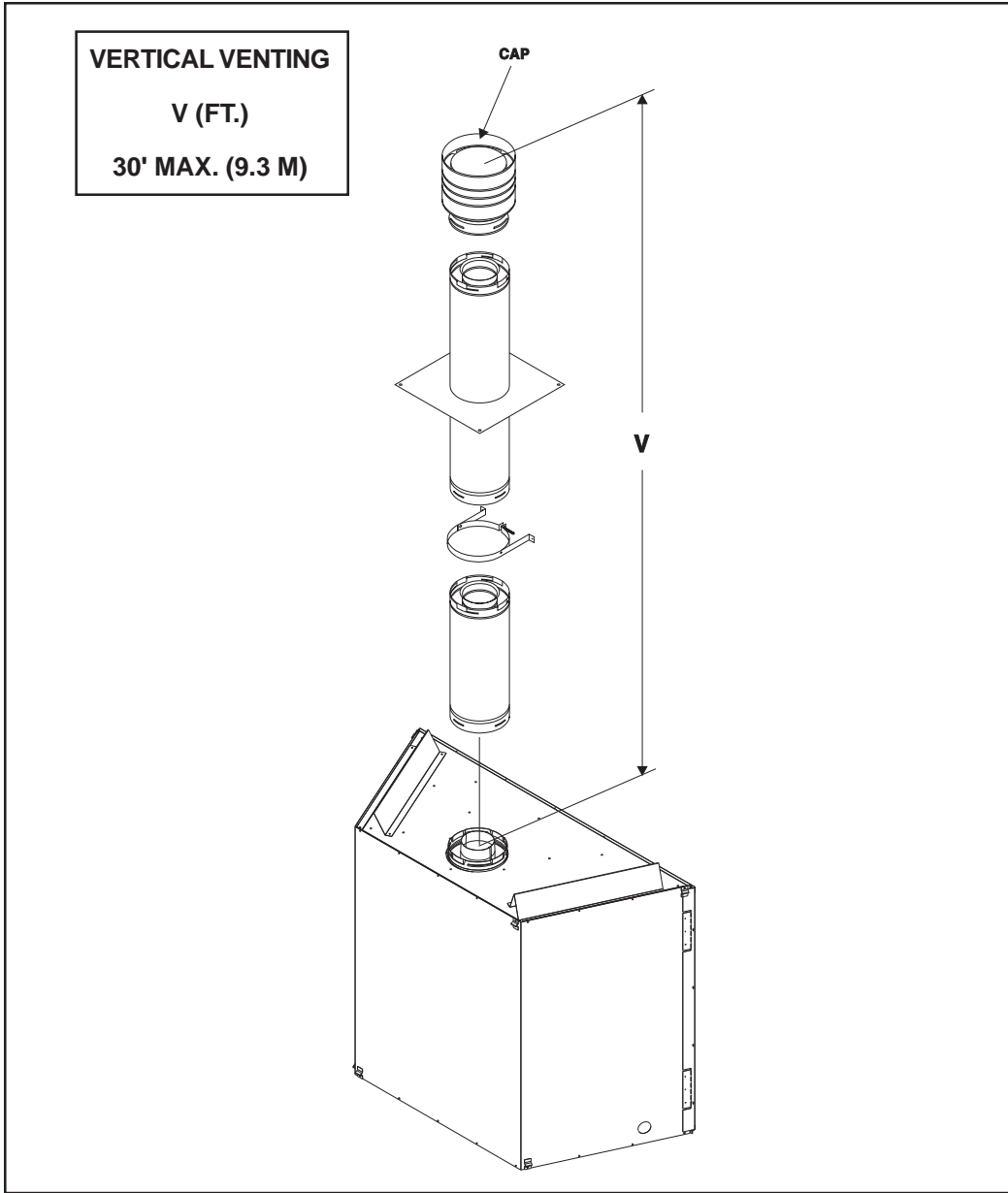

Figure 6. Vertical Venting

VENTING WITH ONE (1) 90° ELBOWS

V (FT.)	H (FT.)
3' MIN. (914 mm)	6' MAX. (1.9m)
4' MIN. (1.2m)	8' MAX. (2.4m)
5' MIN. (1.6m)	10' MAX. (3.1m)
6' MIN. (1.9m)	12' MAX. (3.6m)

V + H = 30' MAX. (9.3 m)
Ratio V to H = 1:2 H = 20' MAX. (6.2m)

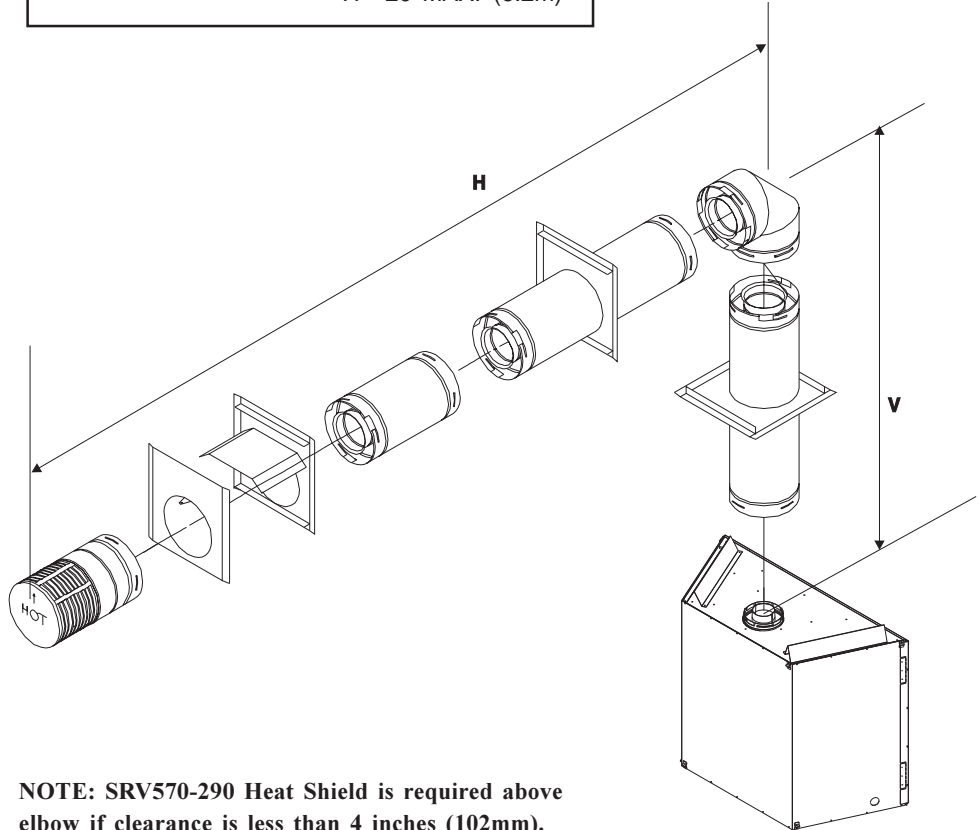

Figure 7. Venting with One 90° Elbow

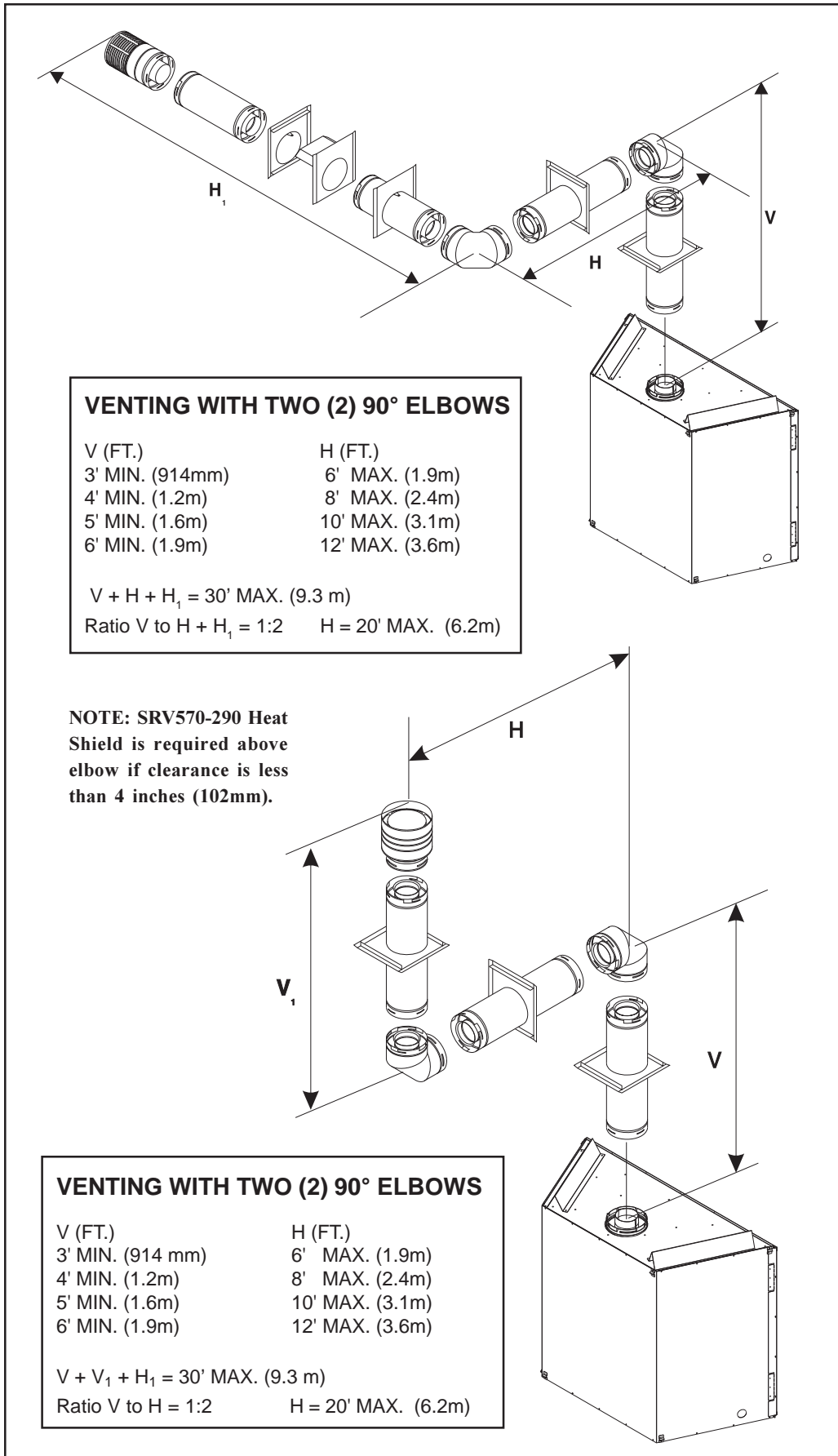

Figure 8. Venting with two 90° elbows

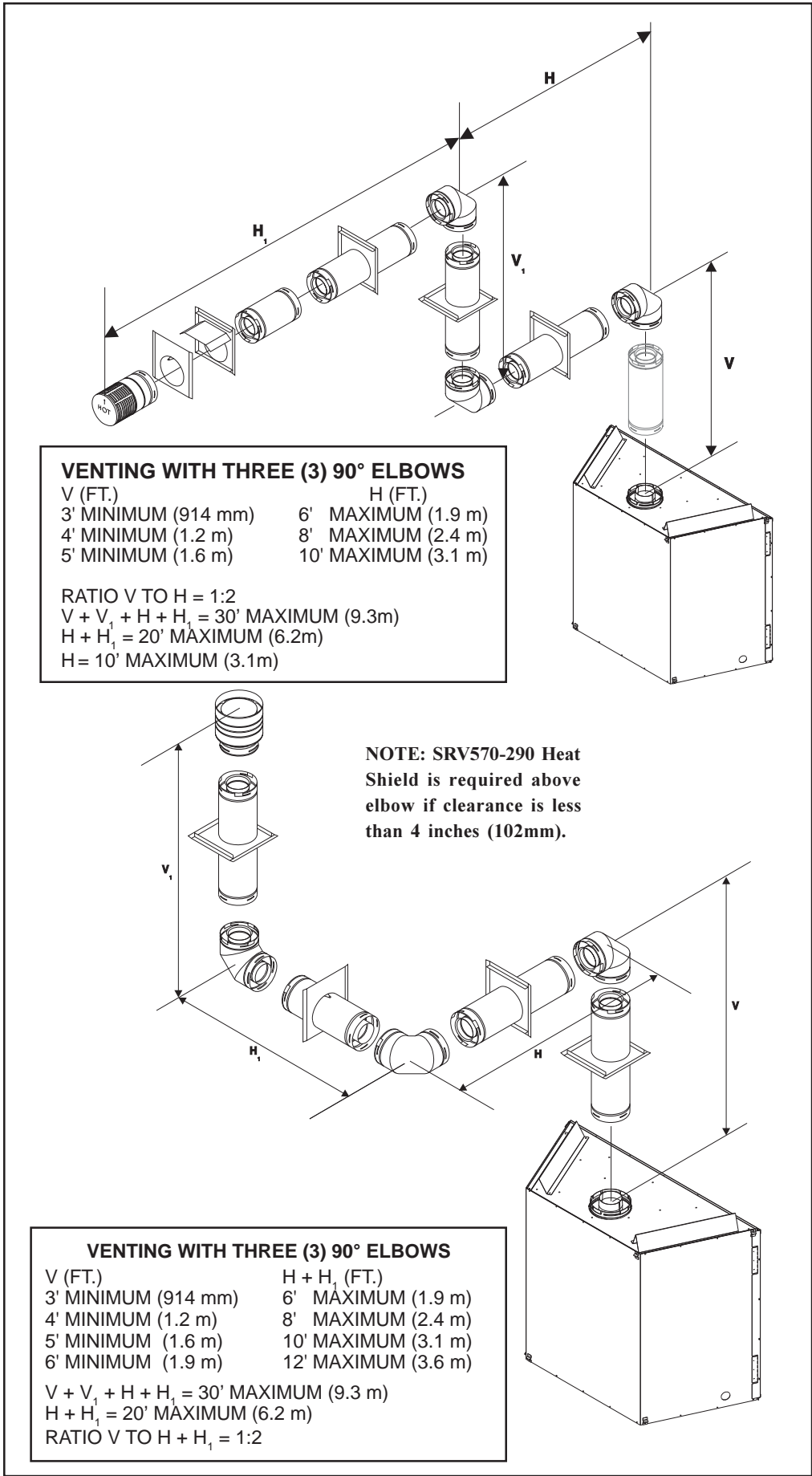

Figure 9. Venting with three 90° elbows

B. Installing Vent Components

1. Attach the First Vent Component to the Starting Collars

To attach the first vent component (3 foot straight pipe minimum) to the starting collars of the fireplace:

- Apply a 3/8 inch (9.5 mm) bead of stove cement around the inner pipe fireplace starting collar.
- Make sure that the fireplace rope gasket supplied with the fireplace seals between the first 8-5/8 inch (219mm) vent component and the fireplace top.
- Lock the vent components into place by sliding the concentric pipe sections with four (4) equally spaced interior beads into the fireplace collar or previously installed component end with four (4) equally spaced indented sections.
- When the internal beads of each outer pipe line up, rotate the pipe section clockwise about one-quarter (1/4) turn. The vent pipe is now locked together.

1. Apply the stove cement.
2. Line up the internal beads and rotate the pipe sections clockwise until locked.
3. Lock the vent components into place.
4. Check the seal on the rope gasket.

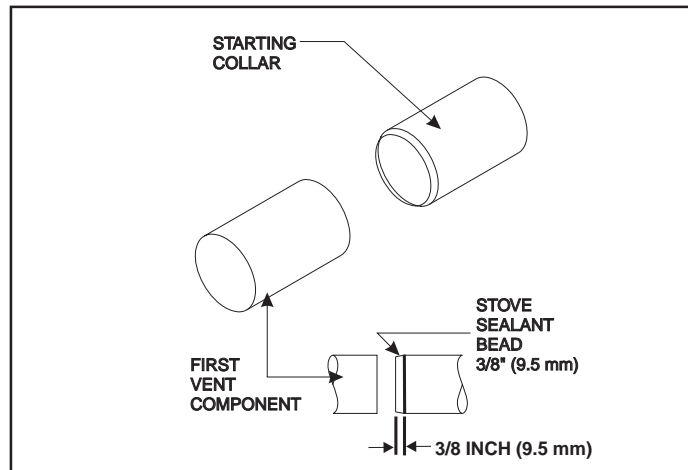

Figure 10. Attaching the First Vent Component to the Starting Collars



WARNING: A 3/8 INCH (9.5 MM) BEAD OF STOVE CEMENT MUST BE PLACED AROUND THE INNER PIPE FIREPLACE STARTING COLLAR BEFORE ATTACHING THE FIRST VENT COMPONENT. FAILURE TO SEAL THIS JOINT MAY CAUSE THE FIREPLACE TO OPERATE IMPROPERLY. SEE THE DIAGRAM .



WARNING: ENSURE THAT THE FIBERGLASS ROPE GASKET SUPPLIED WITH THE FIREPLACE SEALS BETWEEN THE FIRST VENT COMPONENT AND THE FIREPLACE TOP.

2. Continue Adding Vent Components

To continue adding vent components in accordance with the pre-planned vent system configuration:

- Ensure that each succeeding vent component is securely fitted and locked into the preceding component in the vent system.

Continue adding vent components, locking each succeeding component into place.

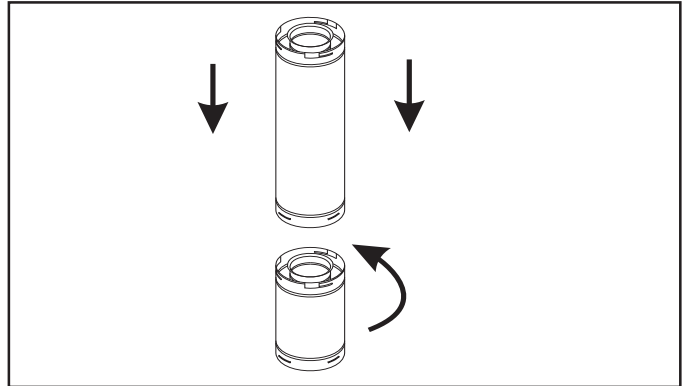

Figure 11. Adding Venting Components

90° elbows may be installed and rotated to any point around the preceding component's vertical axis. If an elbow does not end up in a locked position with the preceding component, attach with a minimum of two (2) sheet metal screws.



WARNING: MODEL GRAND-50 REQUIRES SHIELD SRV570-290 ABOVE THE FIRST 90° ELBOW IN THE SYSTEM IF CLEARANCE IS LESS THAN 4 INCHES (102MM). SEE INSTALLATION SHEET AND HEAT SHIELD SUPPLIED WITH FIREPLACE.

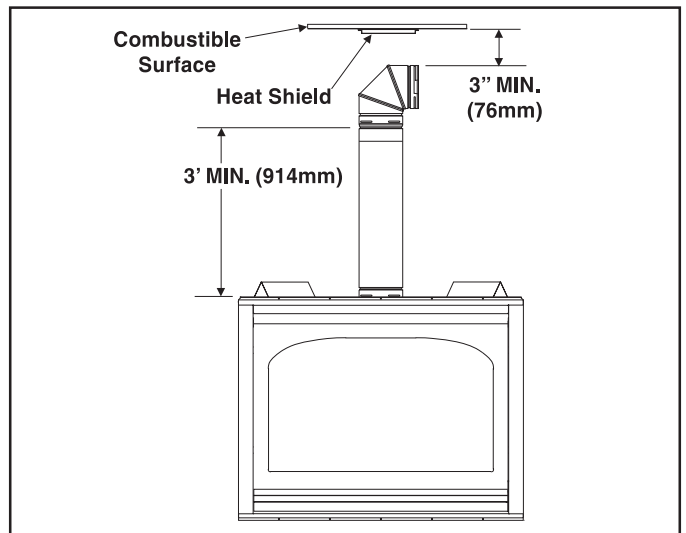

Figure 12. Placement of SRV570-290 Heat Shield First 90 elbow in system.

3. Install Support Brackets

For Horizontal Runs - The vent system must be supported every five (5) feet of horizontal run by a horizontal pipe support.

To install support brackets for horizontal runs:

- Place the pipe supports around the vent pipe.
- Nail the pipe supports to the framing members.

For Vertical Runs - The vent system must be supported every eight (8) feet (2.4 m) above the fireplace flue outlet by wall brackets.

To install support brackets for vertical runs:

- Attach wall brackets to the vent pipe and secure the wall bracket to the framing members with nails or screws.

Use wall brackets to support vertical runs every 8 feet (2.4 m) above the fireplace flue outlet.

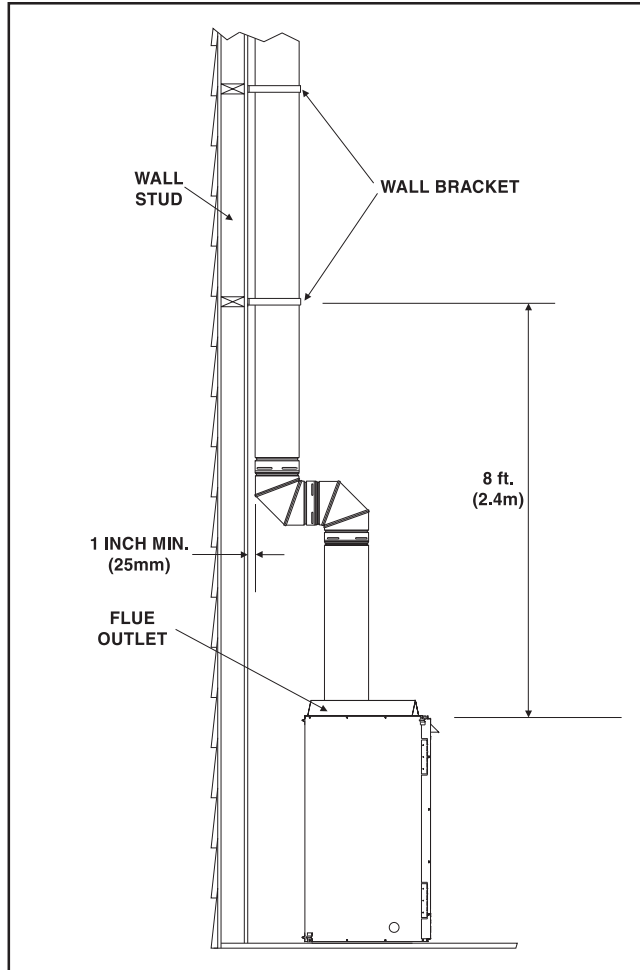

Figure 13. Installing Support Brackets

4. Install Firestops

For Horizontal Runs - Firestops are **REQUIRED** on both sides of a combustible wall through which the vent passes.

NOTE

Model DVK-01TRD does not need an exterior firestop on an exterior combustible wall.

To install firestops for horizontal runs that pass through either interior or exterior walls:

- Cut a 12-inch by 12-inch (305mm X 305mm) hole through the wall. The center of the hole is one (1) inch (25.4 mm) above the center of the horizontal vent pipe.

1. Cut the hole through the wall.

- Position the firestops on both sides of the hole previously cut and secure the firestops with nails or screws.
- The heat shields of the firestops **MUST BE** placed towards the top of the hole.
- Continue the vent run through the firestops.

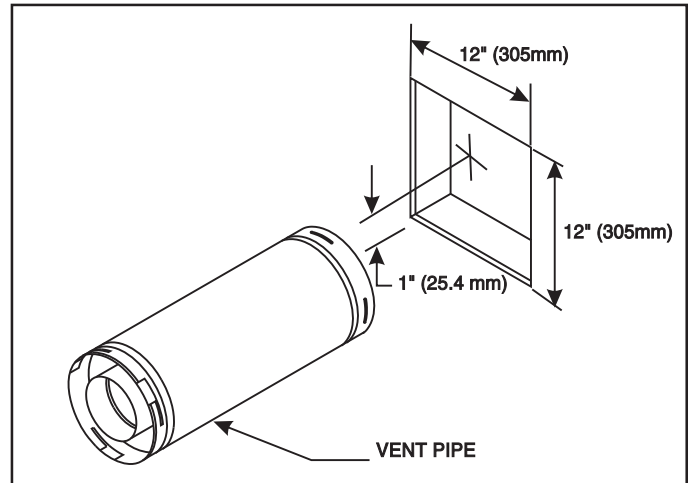

Figure 14. Hole and Vent Pipe

2. Position the firestops.
3. Place the heat shield to the top.
4. Continue the vent run.

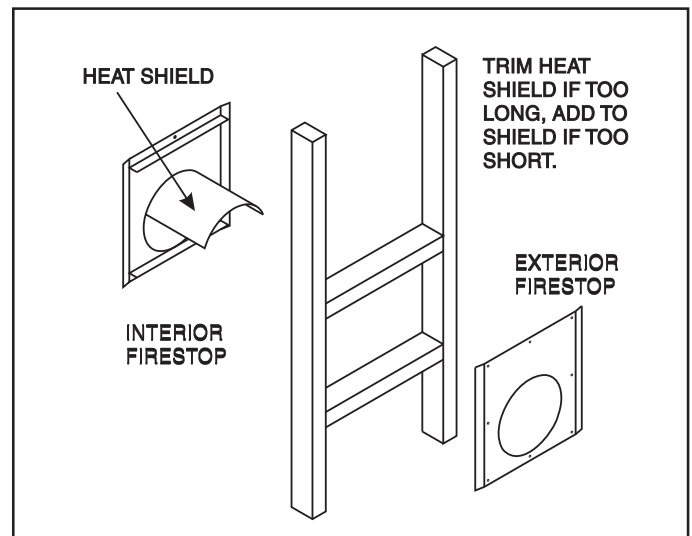

Figure 15. Heat Shield, Interior and Exterior Firestops

For Vertical Runs - One ceiling firestop is **REQUIRED** at the hole in each ceiling through which the vent passes.

To install firestops for vertical runs that pass through ceilings:

- Position a plumb bob directly over the center of the vertical vent component.
- Mark the ceiling to establish the centerpoint of the vent.

- Drill a hole or drive a nail through this centerpoint.
- Check the floor above for any obstructions, such as wiring or plumbing runs.
- Reposition the fireplace and vent system, if necessary, to accommodate the ceiling joists and/or obstructions.
- Cut a 11-inch X 11-inch (280 mm X 280 mm) hole through the ceiling, using the centerpoint previously marked.
- Frame the hole with framing lumber the same size as the ceiling joists.

1. Cut the ceiling hole.
2. Add the new framing members.

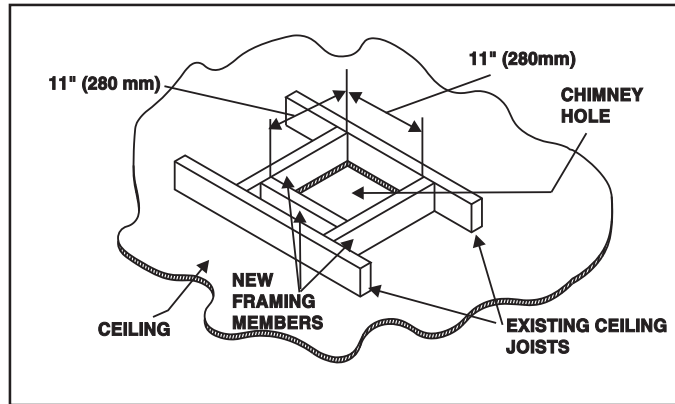

Figure 16. Hole and New Framing Members

If the area above the ceiling is **NOT** an attic, position and secure the ceiling firestop on the ceiling side of the previously cut and framed hole.

This shows a ceiling installation.

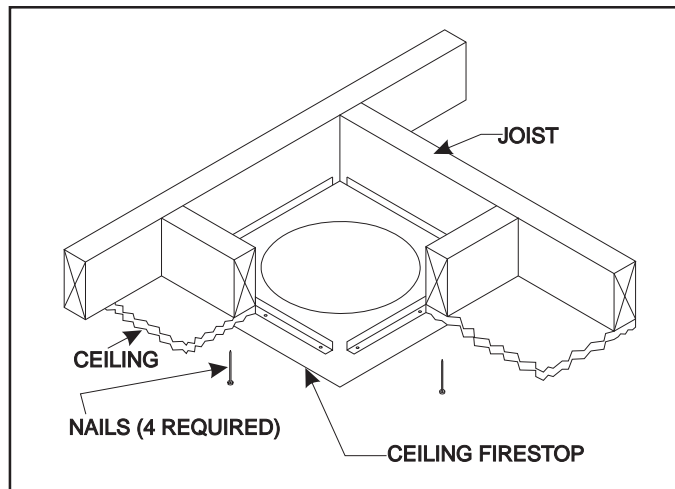

Figure 17. Ceiling Firestop (Ceiling Side)

If the area above the ceiling **IS** an attic, position and secure the firestop on top of the previously framed hole.

This shows an attic installation.

1. Keep insulation away from the vent pipe at least 1 inch (25 mm).

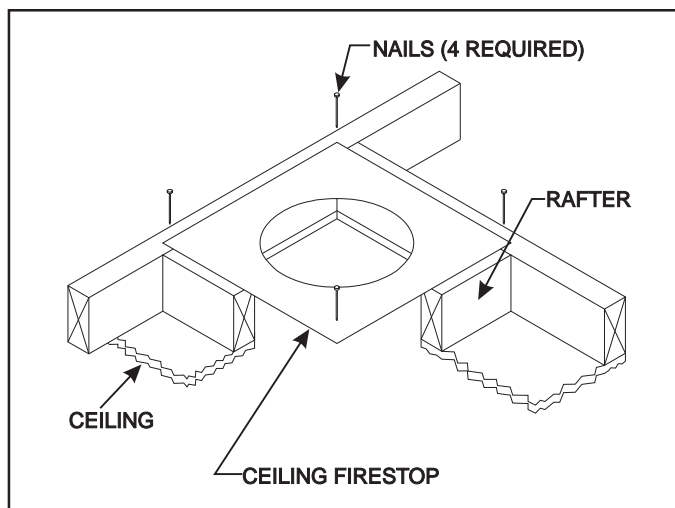

Figure 18. Attic Firestop

C. Vent Termination

For Horizontal Terminations - To attach and secure the termination to the last section of horizontal vent:

- Rotate and interlock the ends as described at the beginning of the Installing Vent Components section.
- The termination kit should pass through the wall firestops from the exterior of the building.
- Adjust the termination cap to its final exterior position on the building.



WARNING

THE TERMINATION CAP MUST BE POSITIONED SO THAT THE ARROW IS POINTING UP.

For roundcap termination kits:

- Use the exterior pipelock hole provided on the round flange of the wall firestop to secure the vent pipe in place.

For trapezoidal cap termination kits:

- Using screws, secure the cap to the exterior wall through the flanges built into the cap.
- Use a high-temperature sealant or fiberglass rope gasket to seal between the pipe and exterior firestop.

For round cap termination:

1. Secure the pipe, using the exterior pipelock hole on the round flange of the wall firestop.

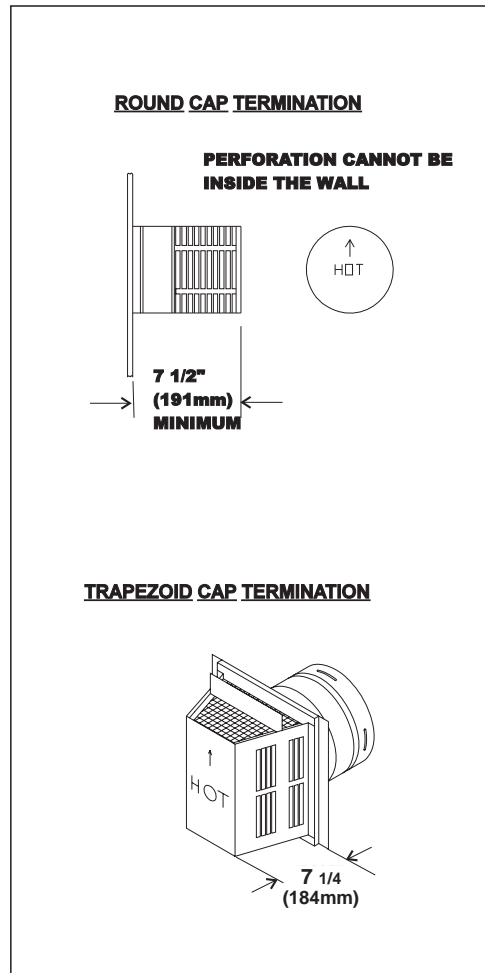

For trapezoidal termination:

1. Screw the cap to the exterior wall through the flanges in the cap.
2. Seal the joint between the pipe and the exterior firestop.

Figure 19. Round and Trapezoid Termination Caps



WARNING
THE BOTTOM OF THE VENT TERMINATION CAP MUST BE A MINIMUM OF 12 INCHES (305MM) ABOVE GROUND LEVEL (GRADE). THE TOP OF THE CAP MUST BE A MINIMUM OF 36 INCHES (914 MM) BELOW COMBUSTIBLE MATERIAL, SUCH AS A DECK, AND THE SIDE OF THE CAP MUST BE A MINIMUM OF 6 INCHES (152 MM) AWAY FROM A PARALLEL OUTSIDE WALL. VENTING TERMINALS SHALL NOT BE RECESSED INTO A WALL OR SIDING. SEE THE FOLLOWING DIAGRAM FOR VENT TERMINATION CLEARANCES.

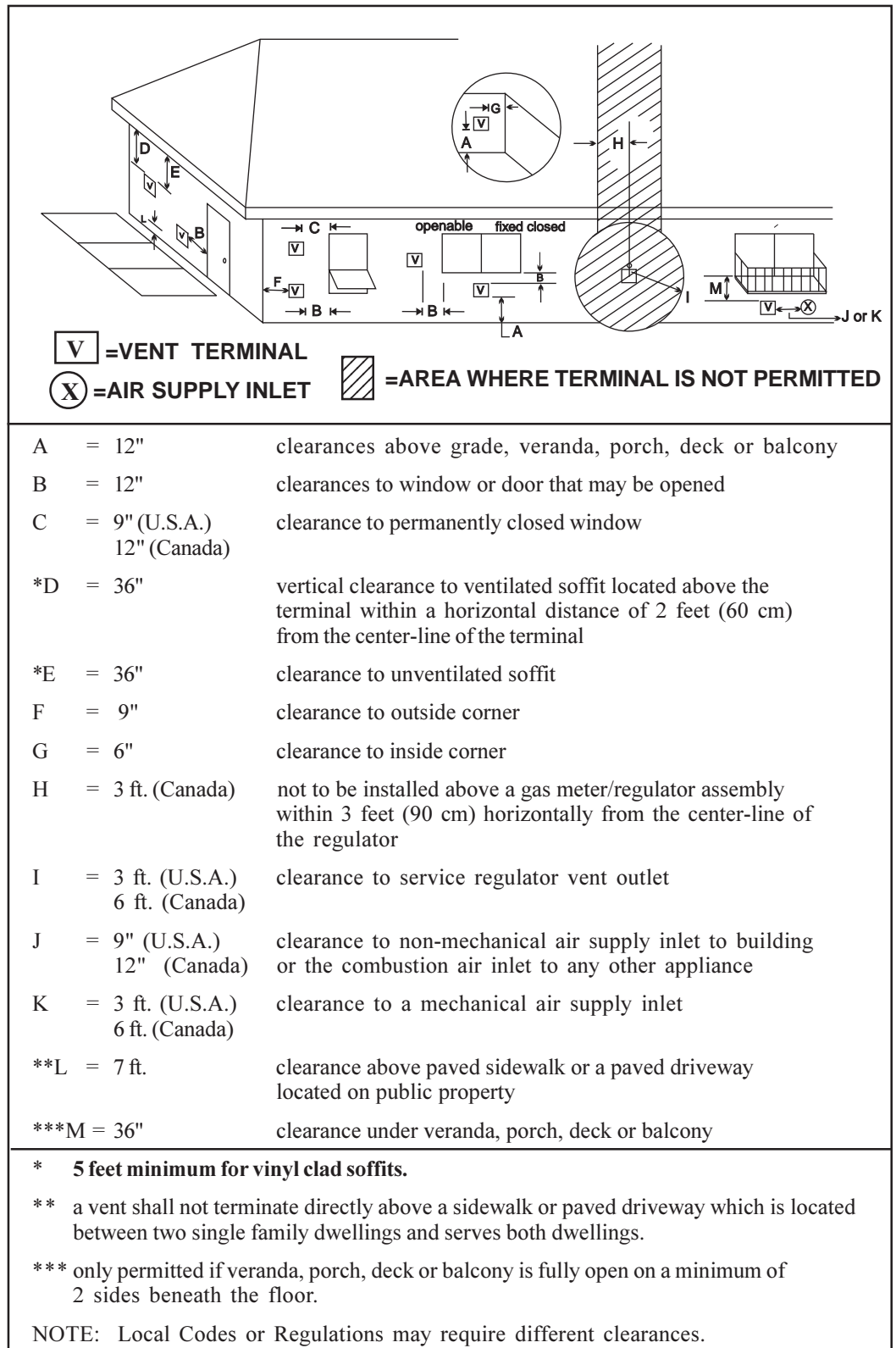

Figure 20. Vent Termination Minimum Clearances

CAUTION

IF EXTERIOR WALLS ARE FINISHED WITH VINYL SIDING, IT IS NECESSARY TO INSTALL TWO VINYL PROTECTOR KITS TO THE TOP OF THE EXTERIOR FIRESTOP (FOR ALL ROUND TERMINATION CAPS). SEE FIGURE 21.

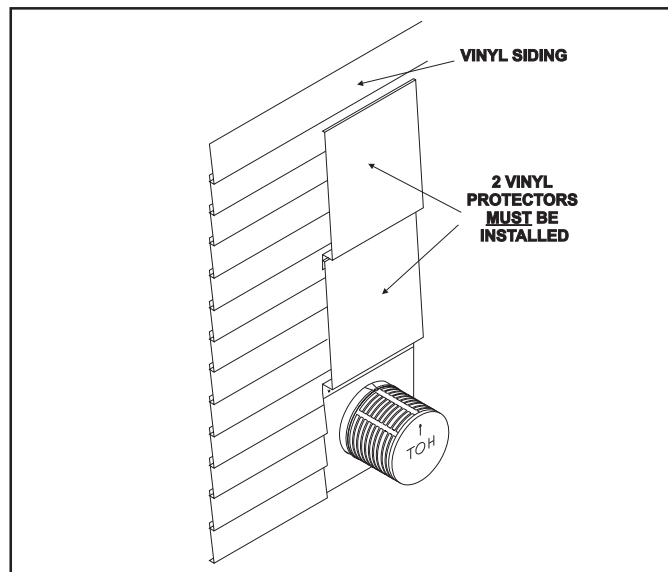

Figure 21. Two Vinyl Protectors

For Vertical Terminations - To locate the vent and install the vent sections:

- Locate and mark the vent centerpoint on the underside of the roof, and drive a nail through the centerpoint.
- Make the outline of the roof hole around the centerpoint nail.
- The size of the roof hole framing dimensions depend on the pitch of the roof. There **MUST BE** a 1-inch (25.4mm) clearance from the vertical vent pipe to combustible materials.
- Mark the roof hole accordingly.
- Cover the opening of the installed vent pipes.
- Cut and frame the roof hole.
- Use framing lumber the same size as the roof rafters and install the frame securely. Flashing anchored to the frame must withstand heavy winds.
- Continue to install concentric vent sections up through the roof hole (for inside vent installations) or up past the roof line until you reach the appropriate distance above the roof (for outside terminations).



WARNING: MAJOR U.S. BUILDING CODES SPECIFY MINIMUM CHIMNEY AND/OR VENT HEIGHT ABOVE THE ROOF TOP. THESE MINIMUM HEIGHTS ARE NECESSARY IN THE INTEREST OF SAFETY. SEE THE FOLLOWING DIAGRAM FOR MINIMUM HEIGHTS, PROVIDED THE TERMINATION CAP IS AT LEAST TWO (2) FEET FROM A VERTICAL WALL AND 2-FEET BELOW A HORIZONTAL OVERHANG.

NOTE

This also pertains to vertical vent systems installed on the outside of the building.

To seal the roof hole, and to divert rain and snow from the vent system:

- Attach a flashing to the roof using nails, and use a non-hardening mastic around the edges of the flashing base where it meets the roof.
- Attach a storm collar over the flashing joint to form a water-tight seal. Place non-hardening mastic around the joint, between the storm collar and the vertical pipe.
- Slide the termination cap over the end of the vent pipe and rotate the pipe clockwise 1/4 turn.

1. Attach the flashing and apply sealant around the edges of the flashing base.
2. Attach the storm collar over the flashing joint and apply sealant between the storm collar and vertical pipe.

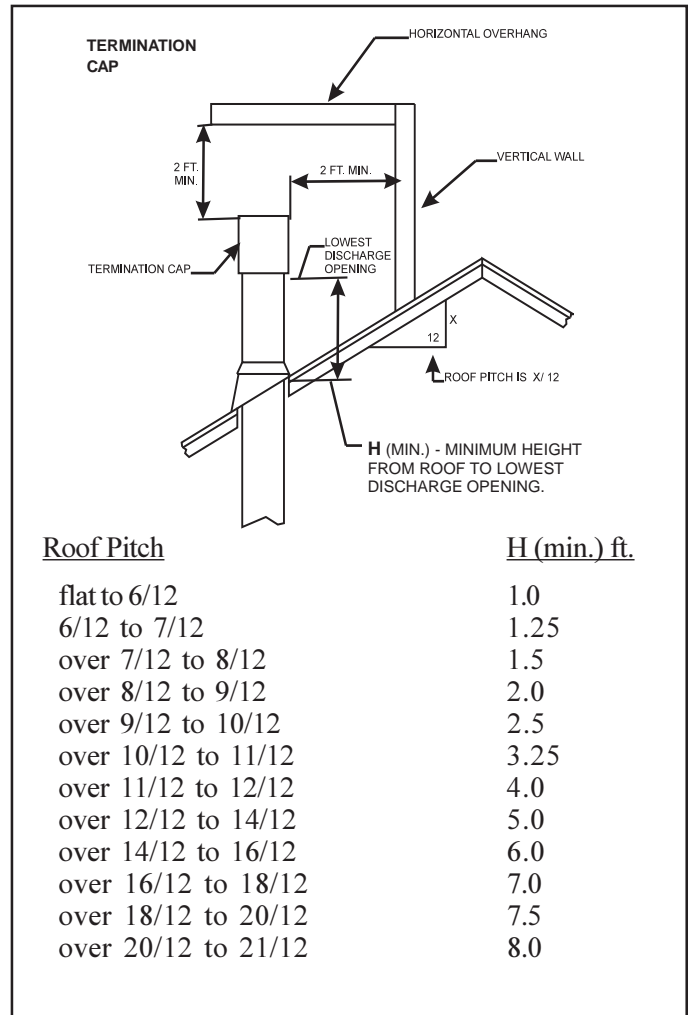

Figure 22. Minimum Height from Roof to Lowest Discharge Opening

Step 4 Positioning, Leveling, and Securing the Fireplace

1. Place the fireplace into position.
2. Level the fireplace from side to side and from front to back.
3. Shim the fireplace with non-combustible material, such as sheet metal, as necessary.
4. Secure the fireplace to the framing by nailing or screwing

The diagram below shows how to properly position, level, and secure the fireplace.

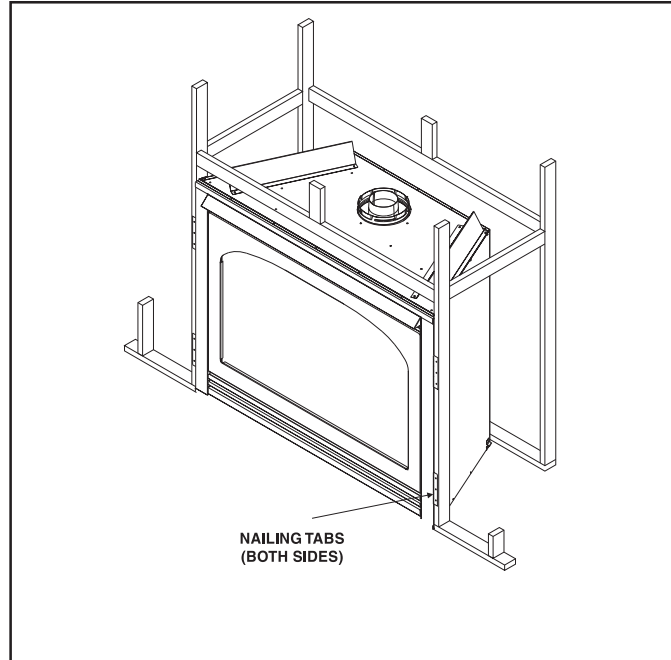

Figure 23. Proper Positioning, Leveling, and Securing of a Fireplace

Step 5 The Gas Control Systems



WARNING: THIS UNIT IS NOT FOR USE WITH SOLID FUEL.

The gas control systems used with these models are *Direct Spark Ignition (DSI)*.

Direct Spark Ignition (DSI) System

This system includes a 120V control valve, electronic module, and spark ignitor/flame sensor.



WARNING: CONTINUOUS 110-120 VAC SERVICE WE MUST BE WIRED TO THE FIREPLACE JUNCTION BOX IN A DSI SYSTEM.



WARNING: DIRECT VENT PROPANE MODELS WITH DSI CONTROL SYSTEMS CANNOT BE USED IN CANADA.

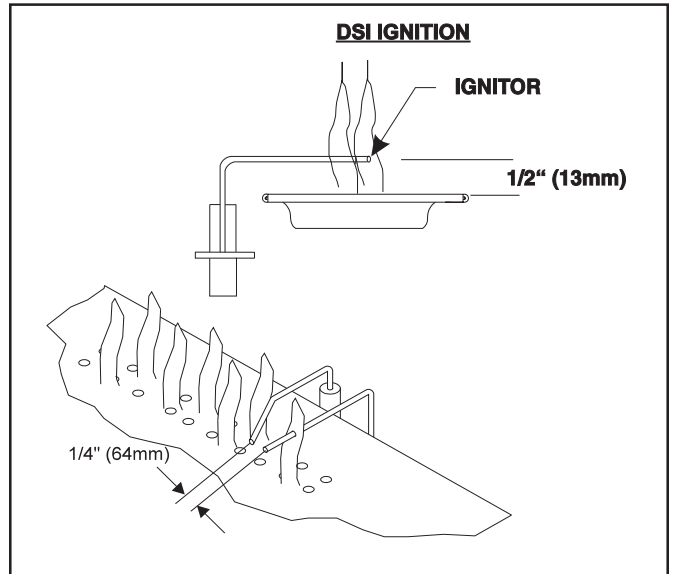

Figure 24. Gas Controls Systems

Step 6 The Gas Supply Line

NOTE: Have the gas supply line installed by a qualified service technician in accordance with all building codes.

NOTES: Before the first firing of the fireplace, the gas supply line should be purged of any trapped air.

NOTE: Consult local building codes to properly size the gas supply line leading to the 1/2 inch (13mm) hook-up at the unit.

This gas fireplace is designed to accept a 1/2 inch (13mm) gas supply line.

To install the gas supply line:

- A listed 1/2 inch (13mm) manual shut-off valve and a listed flexible gas connector are connected to the 1/2 inch (13mm) inlet of the main control valve.
- A 1/8 inch (3mm) N.P.T. plugged tapping, accessible for test gauge connection, should be provided for in the gas supply line leading to the unit's shut-off valve.
- Locate the gas line access hole in the outer casing of the fireplace.
- Open the fireplace lower grille, insert the gas supply line through the gas line hole, and connect it to the shut-off valve.
- When attaching the pipe, support the control so that the lines are not bent or torn.
- After the gas line installation is complete, use a soap solution to carefully check all gas connections for leaks.



WARNING: DO NOT USE AN OPEN FLAME TO CHECK FOR GAS LEAKS.

- At the gas line access hole, use insulation to re-pack the space around the gas pipe.
- Insert insulation from the outside of the fireplace and pack the insulation tightly to totally seal between the pipe and the outer casing.

The gas line should be installed by a qualified service technician.

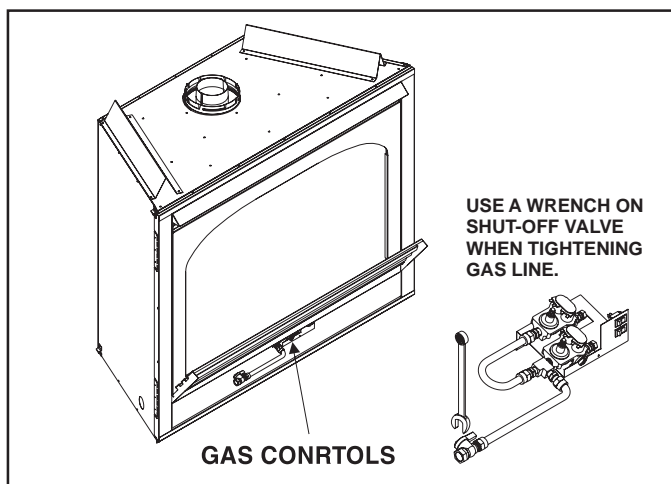

Figure 25. Gas Supply Line

Step 7 Gas Pressure Requirements

Pressure requirements for these gas fireplaces are shown in the table below.

Pressure	Natural Gas	Propane
Minimum Inlet Pressure	7.0 inches w.c.	12.0 inches w.c.
Maximum Inlet Gas Pressure	14.0 inches w.c.	14.0 inches w.c.
Manifold Pressure	3.5 inches w.c.	10.0 inches w.c.

A one-eighth (1/8) inch (3 mm) N.P.T. plugged tapping is provided on the outlet side of the gas control for a test gauge connection to measure the manifold pressure. To measure inlet pressure, provisions must be made to attach a test gauge to a one-eighth (1/8) inch (3 mm) N.P.T. plugged tapping immediately upstream of the gas supply connection to the fireplace.

The fireplace and its individual shut-off valve must be disconnected from the gas supply piping system during any pressure testing of the system at test pressures in excess of one-half (1/2) psig (3.5 kPa).

The fireplace must be isolated from the gas supply piping system by closing its individual shut-off valve during any pressure testing of the gas supply piping system at test pressures equal to or less than one-half (1/2) psig (3.5 kPa).

Step 8 Wiring the Fireplace

NOTE: Electrical wiring must be installed by a licensed electrician.

DISCONNECT REMOTE CONTROLS IF YOU ARE ABSENT FOR EXTENDED TIME PERIODS. THIS WILL PREVENT ACCIDENTAL FIREPLACE OPERATION.

For Direct Spark Ignition (DSI) Wiring

Appliance Requirements

This appliance requires that 110-120 VAC be wired to the factory installed junction box. Maintain correct polarity when wiring the junction box.

Optional Accessories

Optional fan and remote control kits require that 110-120 VAC be wired to the fireplace junction box.

CAUTION

ANY REMOTE SWITCHING DEVICE USED FOR SETTING THE BURNER "HI" OR "LOW" MUST BE CONNECTED TO THE CORRECT PIGTAIL WIRES. SEE WIRING DIAGRAM FIGURE 26.

Remote Wall Switch

Position the remote wall switch in the desired position on a wall. Run a maximum of 25 feet (7.8 m) or less of 16 A.W.G. minimum wire and connect it to the fireplace ON/OFF switch pigtails.

NOTE

Electrical wiring must be installed by a licensed electrician.

CAUTION

LABEL ALL WIRES PRIOR TO DISCONNECTION WHEN SERVICING CONTROLS. WIRING ERRORS CAN CAUSE IMPROPER AND DANGEROUS OPERATION. VERIFY PROPER OPERATION AFTER SERVICING

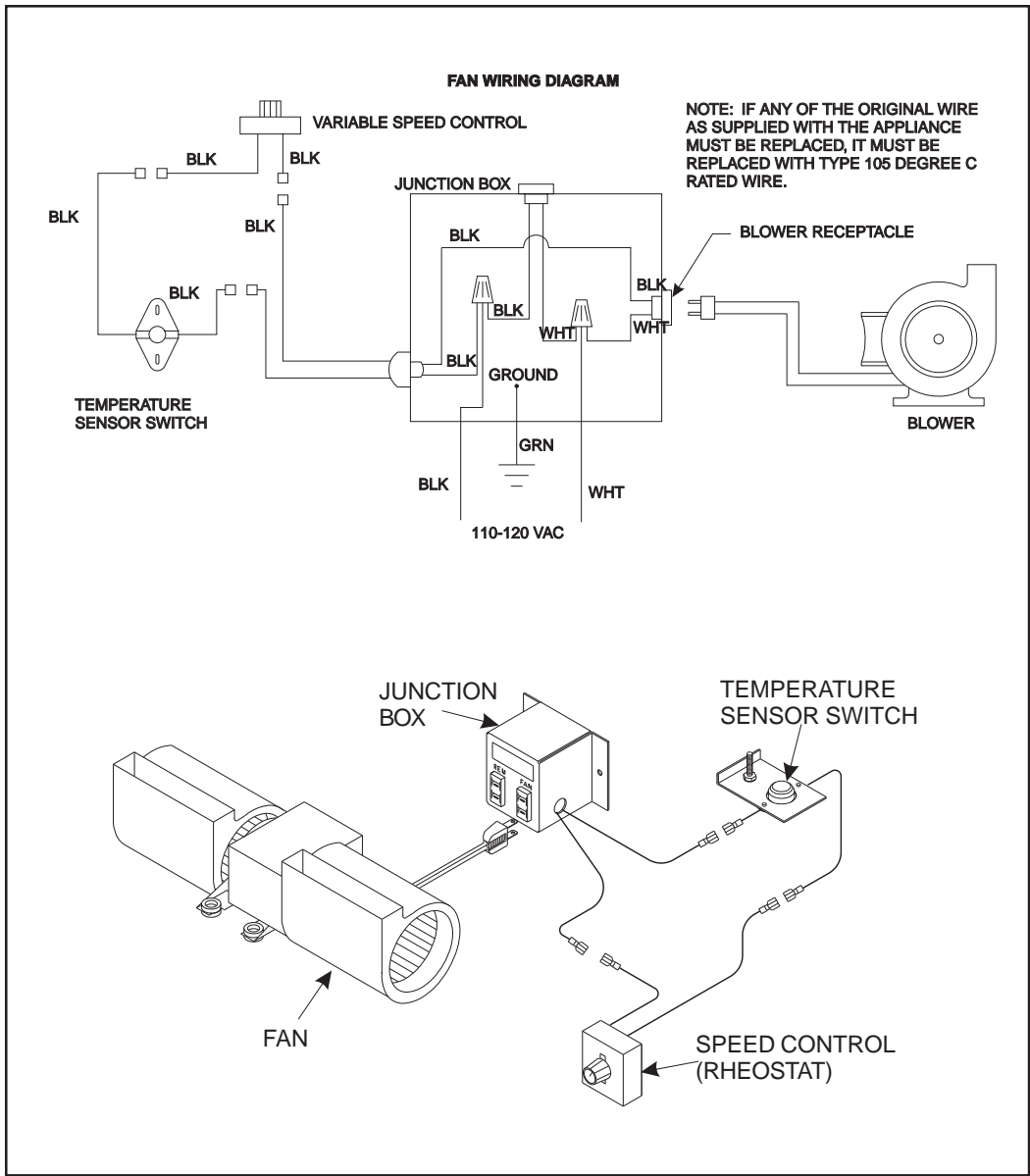

Figure 26. Fan Wiring Diagram

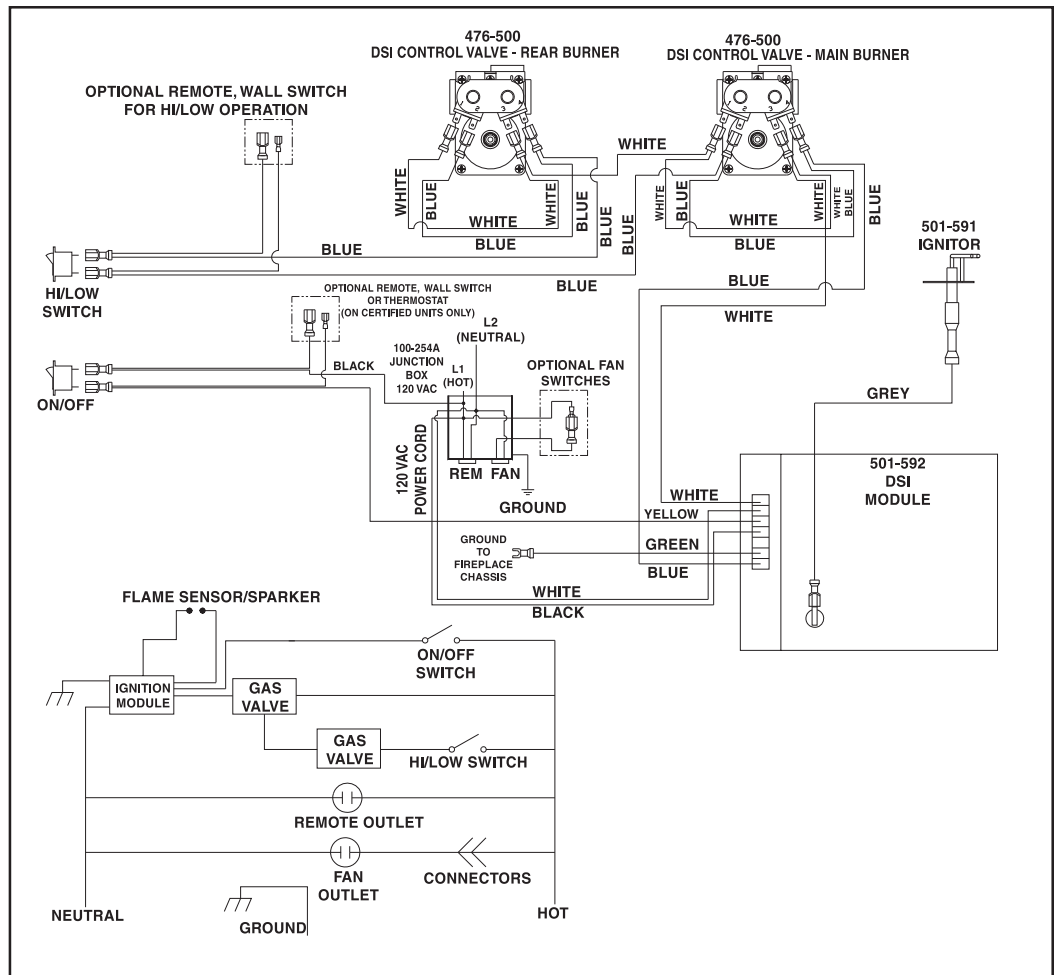

Figure 27. Direct Spark Ignition (DSI) Wiring Diagram

Step 9 Finishing

Only non-combustible materials may be used to cover the black fireplace front.

The following diagram shows the minimum vertical and corresponding maximum horizontal dimensions of fireplace mantels or other combustible projections above the top front edge of the fireplace. See Figures 2 and 3 for other fireplace clearances.

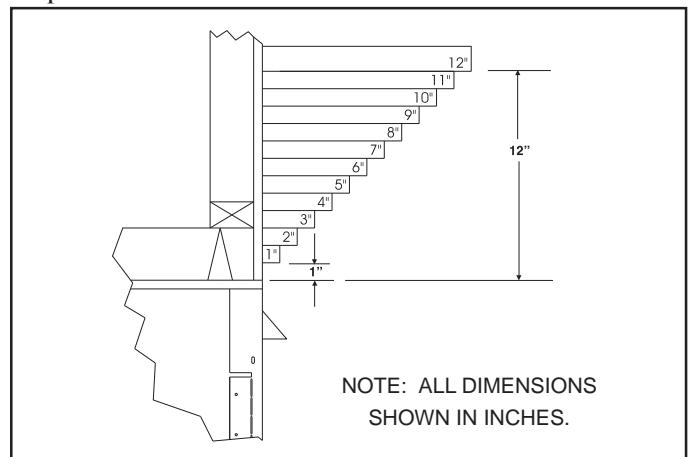

Figure 28. Minimum Vertical and Maximum Horizontal Dimensions of Combustibles above Fireplace

WARNING: WHEN FINISHING THE FIREPLACE, NEVER OBSTRUCT OR MODIFY THE AIR INLET/OUTLET GRILLES IN ANY MANNER.

CAUTION

IF JOINTS BETWEEN THE FINISHED WALLS AND THE FIREPLACE SURROUND (TOP AND SIDES) ARE SEALED, A 300° F. MINIMUM SEALANT MATERIAL MUST BE USED. THESE JOINTS ARE NOT REQUIRED TO BE SEALED. ONLY NON-COMBUSTIBLE MATERIAL (USING 300° F. MINIMUM ADHESIVE, IF NEEDED) CAN BE APPLIED AS FACING TO THE FIREPLACE SURROUND. SEE THE DIAGRAM SHOWN BELOW.

1. Apply only non-combustible facing material to the fireplace surround.

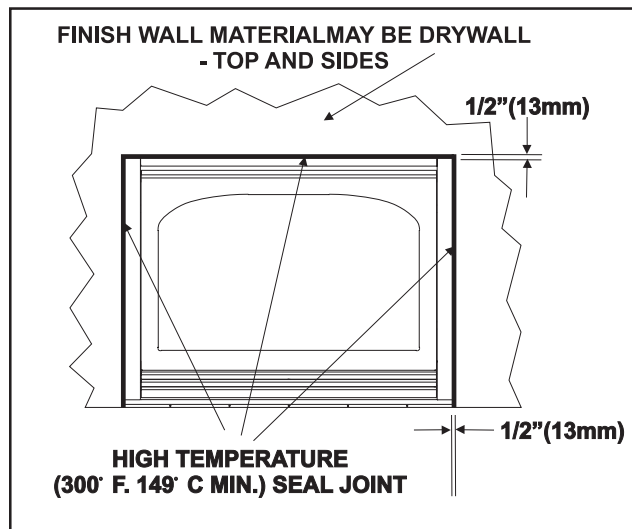

Figure 29. Sealant Material

Hearth Extensions

A hearth extension may be desirable for aesthetic reasons. However, ANSI or CAN/CGA testing standards **do not** require hearth extensions for gas fireplace appliances.

Step 10 Installing Trim, Logs, and Ember Material

Installing the Trim

Combustible materials may be brought up to the specified clearances on the side and top front edges of the fireplace, but **MUST NEVER** overlap onto the front face. The joints between the finished wall and the fireplace top and sides can only be sealed with a 300° F. (149° C) minimum sealant.



WARNING
WHEN FINISHING THE FIREPLACE,
NEVER OBSTRUCT OR MODIFY THE
AIR INLET/OUTLET GRILLES IN
ANY MANNER.

Install optional marble and brass trim surround kits as desired. Marble, brass, brick, tile, or other non-combustible materials can be used to cover up the gap between the sheet rock and the fireplace.

Do not obstruct or modify the air inlet/outlet grilles. When overlapping on both sides, leave enough space so that the bottom grille can be lowered and the trim door removed.

Positioning the Logs

If the gas logs have been factory installed they should not need to be positioned.

If the logs have been packaged separately, refer to the installation instructions that accompany the logs. **Save the log instructions with this manual.**

If sooting occurs, the logs might need to be repositioned slightly to avoid excessive flame impingement.

Placing the Ember Material

Three separate bags of ember material are shipped with this gas fireplace:

- The bag labeled Golden Ember (GE-93) is flame colorant material.
- The bags labeled Glowing Ember (050-721) are standard glowing ember material.

To place the ember material:

- Remove the wing nuts and glass clips around the glass door.
- Remove the glass door from the unit.
- Cover the top of the burner with a single layer of ember material. Then sprinkle GE-93 on top of the burner.
- Save the remaining ember materials for use during fireplace servicing.
- Replace the glass door and a front trim door on the unit (see Replacement Parts Section of the manual.)
- Replace the wing nuts, and glass clips.
- Hand tighten the wing nuts.

1. Lift the trim door up and away from the unit.
2. Remove the wing nuts, and glass clips, and the glass door from the unit.

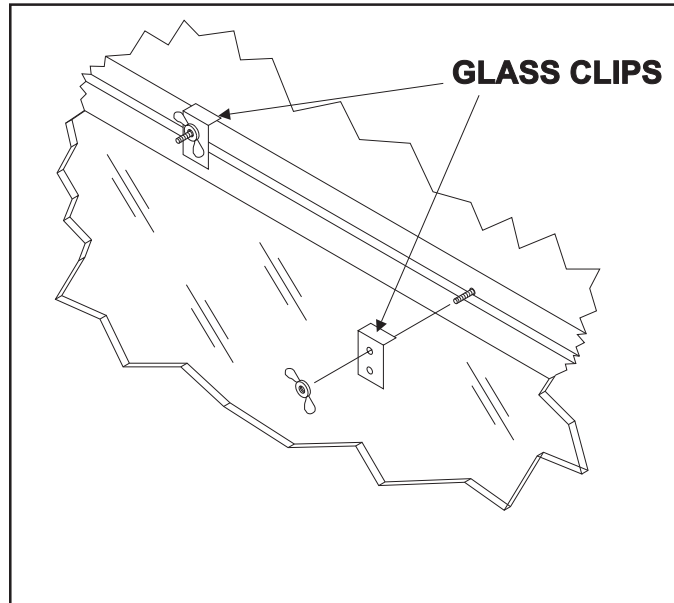

Figure30. Glass Assembly

CAUTION

HAND TIGHTEN THE WING NUTS, BUT BE CAREFUL NOT TO OVERTIGHTEN.

1. Place the ember material onto the top of the burner.

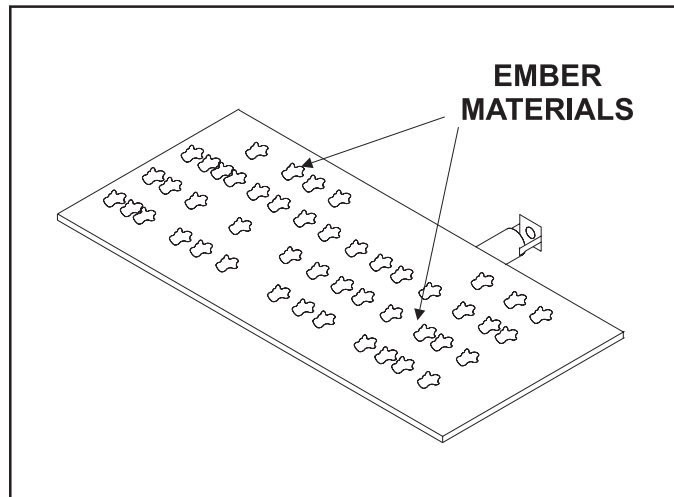

Figure 31. Follow placement of the ember material

CAUTION

IT IS STRONGLY RECOMMENDED THAT TRIM DOORS WITH OPTIONAL MESH SCREENS BE INSTALLED ON PROPANE MODELS.

Step 11 Before Lighting the Fireplace

Before lighting the fireplace, be sure to do the following:

Review safety warnings and cautions

- Read the **Safety and Warning Information** section at the beginning of this *Installers Guide*.

Double-check for gas leaks

- Before lighting the fireplace, double-check the unit for possible gas leaks.

Double-check vent terminations and front grilles for obstructions.

- Before lighting the fireplace, double-check the unit for possible obstructions that could be blocking the vent terminations or the front grilles.

Double-check for faulty components

- Any component that is found to be faulty **MUST BE** replaced with an approved component. Tampering with the fireplace components is **DANGEROUS** and voids all warranties.

A small amount of air will be in the gas supply lines. When first lighting the fireplace, it will take a few minutes for the lines to purge themselves of this air. Once the purging is complete, the fireplace will light and will operate normally.

Subsequent lightings of the fireplace will not require this purging of air from the gas supply lines, **unless the gas valve has been turned to the OFF position**, in which case the air would have to be purged.

You've reviewed all safety warnings, you've checked the fireplace for gas leaks, you know the vent system is unobstructed, and you've checked for faulty components. Now you're ready to light the fireplace.



WARNING
PLEASE REFER TO THE USER'S
MANUAL FOR ALL CAUTIONS, SAFETY,
AND WARNING INFORMATION
PERTAINING TO THE LIGHTING AND
OPERATION OF THE FIREPLACE.

The main and rear burners of this model are lit independently by two **ON/OFF** rocker switches. The main burner **MUST** be **ON** before the rear burner can be lit. The rear burner can be either **ON** or **OFF** without affecting the main burner. See unit wiring diagram - Figure 26.



LEAVE THIS INSTALLATION MANUAL
WITH THE APPLIANCE FOR FUTURE
REFERENCE.

Step 12 Lighting the Fireplace

After the Installation

Fireplace Maintenance

Although the frequency of your fireplace servicing and maintenance will depend on use and the type of installation, you should have a qualified service technician perform an appliance check-up at the beginning of each heating season. See the table below for specific guidelines regarding each fireplace maintenance task.

IMPORTANT

TURN OFF THE GAS BEFORE SERVICING YOUR FIREPLACE.

Type of Fireplace Maintenance	Frequency	By	Fireplace Maintenance Task To Be Completed
Replacing Old Ember Material	Once annually, during the annual check-up	Qualified Service Technician	Brush away loose ember material near the burner. Replace old ember material with new dime-size and -shape pieces of Golden Ember (GE-93) and Glowing Ember (050-721). New ember material should be placed alternately on top of the burner—a layer of Golden Ember, a layer of Glowing Ember, and so on. Save the remaining ember material and repeat this procedure at your next servicing. For more information, see Placing Ember Material in this manual.
Cleaning Burner & Controls	Once annually	Qualified Service Technician	Brush or vacuum the control compartment, fireplace logs, and burner areas surrounding the logs.
Checking Flame Patterns, Flame Height	Periodically	Qualified Service Technician/ Owner	Make a visual check of your fireplace's flame patterns. Make sure the flames are steady—not lifting or floating. See the picture in Figure 32. The flame sensor (DSI) tips should be covered with flame. See the picture in Figure 33.
Checking Vent System	Before initial use and at least annually thereafter, more frequently if possible	Qualified Service Technician/ Owner	Inspect the external vent cap on a regular basis to ensure that no debris is interfering with the flow of air. Inspect the entire vent system for proper function.
Cleaning Glass Door	As necessary	Homeowner	Clean as necessary, particularly after adding new ember (flame colorant) material. Film deposits on the inside of the glass door should be cleaned off using a household glass cleaner. NOTE: DO NOT handle or attempt to clean the door when it is hot and DO NOT use abrasive cleaners.

4

Maintaining and Servicing Your Fireplace

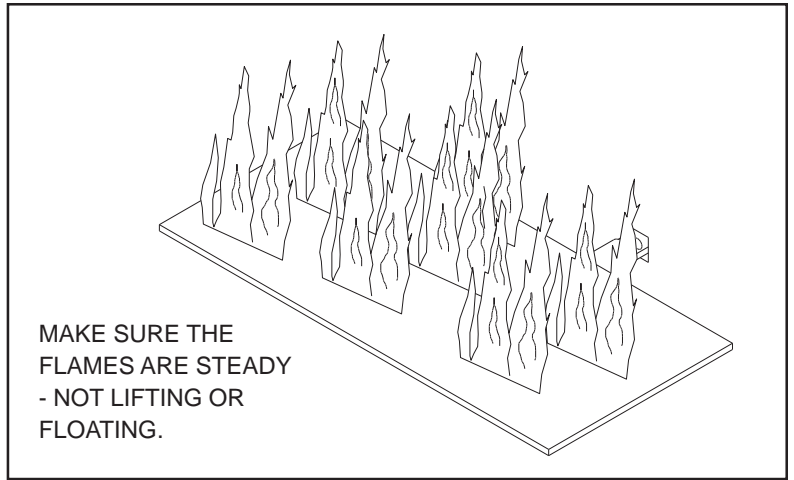

Figure 32. Burner Flame Patterns

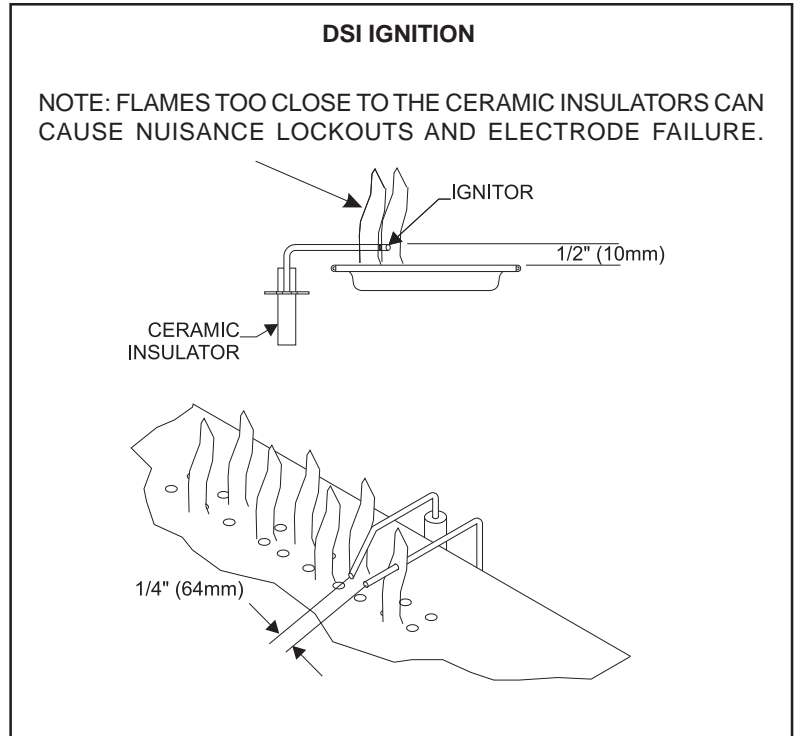

Figure 33. Ignitor Flame Patterns