

This appliance has been retired.
Service parts pages within have been removed.
For replacement parts, please refer to the individual
service parts list located on the brand websites.

Royal[®]
Fireplaces

Installers Guide

Models:

R-3500TR

R-3500TRH

R-4500TR

R-4500TRH

R-6500TR

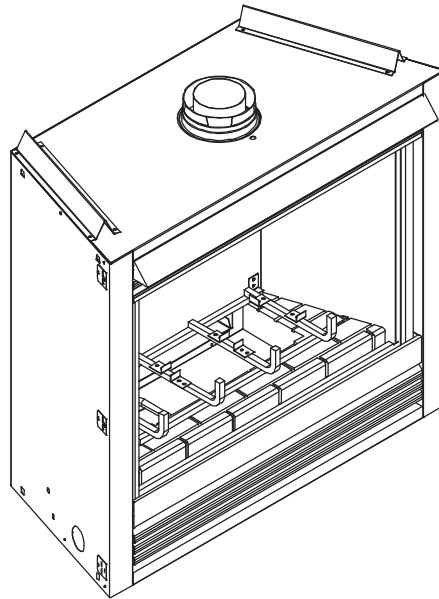

WARNING: IF THE INFORMATION IN THESE INSTRUCTIONS IS NOT FOLLOWED EXACTLY, A FIRE OR EXPLOSION MAY RESULT CAUSING PROPERTY DAMAGE, PERSONAL INJURY, OR DEATH.

- Do not store or use gasoline or other flammable vapors and liquids in the vicinity of this or any other appliance.
- **What to do if you smell gas**
 - Do not try to light any appliance.
 - Do not touch any electrical switch.
 - Do not use any phone in your building.
 - Immediately call your gas supplier from a neighbor's phone. Follow the gas supplier's instructions.
 - If you cannot reach your gas supplier, call the fire department.
- Installation and service must be performed by a qualified installer, service agency, or the gas supplier.

READ THIS MANUAL BEFORE INSTALLING OR OPERATING THIS APPLIANCE. THIS *INSTALLERS GUIDE* MUST BE LEFT WITH THE APPLIANCE FOR FUTURE REFERENCE.

WARNING: IMPROPER INSTALLATION, ADJUSTMENT, ALTERATION, SERVICE OR MAINTENANCE CAN CAUSE INJURY OR PROPERTY DAMAGE. REFER TO THIS MANUAL. FOR ASSISTANCE OR ADDITIONAL INFORMATION CONSULT A QUALIFIED INSTALLER, SERVICE AGENCY, OR THE GAS SUPPLIER.

1. This appliance may be installed in an after-market, permanently located, manufactured (mobile) home, where not prohibited by local codes.
2. This appliance is only for use with the type of gas indicated on the rating plate. This appliance is not convertible for use with other gases, unless a certified kit is used.

Printed in U.S.A. Copyright 2000,
Hearth Technologies Inc.
20802 Kensington Blvd., Lakeville, MN 55044

Please contact your Royal Fireplaces dealer for any questions or concerns. For the number of your nearest Royal Fireplaces dealer, please call 1-800-393-9484.

This product is covered by one or more of the following patents: (United States) 4,112,913; 4,408,594; 4,422,426; 4,424,792; 4,520,791; 4,793,322; ,852,548; 4,875,464; 5,000,162; 5,016,609; 5,076,254 5,191,877; 5,218,953; 5,328,356; 5,429,495; 5,452,708; 5,542,407; 5,613,487; (Australia) 543790; 586383; (Canada) 1,123,296; 1,297,746; 2,195,264; (Mexico) 97-0457; (New Zealand) 200265; or other U.S. and foreign patents pending.

SAFETY AND WARNING INFORMATION



READ and **UNDERSTAND** all instructions carefully before starting the installation. **FAILURE TO FOLLOW** these installation instructions may result in a possible fire hazard and will void the warranty.



Prior to the first firing of the fireplace, **READ** the Using Your Fireplace section of the *Owners Guide*.



DO NOT USE this appliance if any part has been under water. Immediately **CALL** a qualified service technician to inspect the unit and to replace any part of the control system and any gas control which has been under water.



THIS UNIT IS NOT FOR USE WITH SOLID FUEL.



Installation and repair should be **PERFORMED** by a qualified service person. The appliance and venting system should be **INSPECTED** before initial use and at least annually by a professional service person. More frequent cleaning may be required due to excessive lint from carpeting, bedding material, etc. It is **IMPERATIVE** that the unit's control compartment, burners, and circulating air passageways **BE KEPT CLEAN** to provide for adequate combustion and ventilation air.



Always **KEEP** the appliance clear and free from combustible materials, gasoline, and other flammable vapors and liquids.



NEVER OBSTRUCT the flow of combustion and ventilation air. Keep the front of the appliance **CLEAR** of all obstacles and materials for servicing and proper operations.



Due to the high temperature, the appliance should be **LOCATED** out of traffic areas and away from furniture and draperies. Clothing or flammable material **SHOULD NOT BE PLACED** on or near the appliance.



Children and adults should be **ALERTED** to the hazards of high surface temperature and should **STAY AWAY** to avoid burns or clothing ignition. Young children should be **CAREFULLY SUPERVISED** when they are in the same room as the appliance.



These units **MUST** use one of the vent systems described in the Installing the Fireplace section of the *Installers Guide*. **NO OTHER** vent systems or components **MAY BE USED**.



This gas fireplace and vent assembly **MUST** be vented directly to the outside and **MUST NEVER** be attached to a chimney serving a separate solid fuel burning appliance. Each gas appliance **MUST USE** a separate vent system. Common vent systems are **PROHIBITED**.



INSPECT the external vent cap on a regular basis to make sure that no debris is interfering with the air flow.



The glass door assembly **MUST** be in place and sealed, and the trim door assembly **MUST** be in place on the fireplace before the unit can be placed into safe operation.



DO NOT OPERATE this appliance with the glass door removed, cracked, or broken. Replacement of the glass door should be performed by a licensed or qualified service person. **DO NOT** strike or slam the glass door.



The glass door assembly **SHALL ONLY** be replaced as a complete unit, as supplied by the gas fireplace manufacturer. **NO SUBSTITUTE** material may be used.



DO NOT USE abrasive cleaners on the glass door assembly. **DO NOT ATTEMPT** to clean the glass door when it is hot.



Turn off the gas before servicing this appliance. It is recommended that a qualified service technician perform an appliance check-up at the beginning of each heating season.



Any safety screen or guard removed for servicing must be replaced before operating this appliance.

Safety and Warning Information	2
Section 1: Approvals and Codes	4
Approval Listings and Codes	4
Appliance Certification	4
Installation Codes	4
High Altitude Installations	5
Section 2: Getting Started	6
Introducing the Royal Fireplaces	6
Pre-installation Preparation	6
Section 3: Installing the Fireplace	10
◆ Step 1 Locating the Fireplace	10
Step 2 Framing the Fireplace	11
Step 3 Installing the Vent System	12
◆ A. Vent System Approvals	12
B. Installing Vent Components	30
C. Vent Termination	36
Step 4 Positioning, Leveling, and Securing the Fireplace	41
Step 5 The Gas Control Systems	41
Step 6 The Gas Supply Line	42
Step 7 Gas Pressure Requirements	43
Step 8 Wiring the Fireplace	44
◆ Step 9 Finishing	46
Step 10 Installing Trim, Logs, and Ember Material ...	47
Installing the Trim	47
Positioning the Logs	48
◆ Placing the Ember Material	48
Step 11 Before Lighting the Fireplace	50
Step 12 Lighting the Fireplace	50
After the Installation	50
Section 4: Maintaining and Servicing Your Fireplace	51
Section 5: Replacement Parts and Accessories	53
Replacement Parts	53
◆ Accessories	58

Table of Contents

1

Approvals and Codes

Approval Listings and Codes

Appliance Certification

The Royal Fireplaces models discussed in this *Installers Guide* have been tested to certification standards and listed by the applicable laboratories.

MODEL	LABORATORY	TYPE	CERTIFICATION STANDARD
R-6500TR	Underwriters Laboratories	Direct Vent Gas Fireplace	ANSI Z21.50•CGA2.22
R-4500TR	Underwriters Laboratories	Direct Vent Gas Fireplace	ANSI Z21.50• CGA2.22
R-4500TRH	Underwriters Laboratories	Direct Vent Gas Fireplace Heater	ANSI Z21.88• CGA2.33
R-3500TR	Underwriters Laboratories	Direct Vent Gas Fireplace	ANSI Z21.50•CGA2.22
R-3500TRH	Underwriters Laboratories	Direct Vent Gas Fireplace Heater	ANSI Z21.88• CGA2.33

NOTE: ALL MODELS ARE UL LISTED TO UL307B, THE STANDARD FOR GAS-BURNING HEATING APPLIANCES FOR MANUFACTURED HOMES AND RECREATIONAL VEHICLES.

Installation Codes

The fireplace installation must conform to local codes. Before installing the fireplace, consult the local building code agency to ensure that you are in compliance with all applicable codes, including permits and inspections.

In the absence of local codes, the fireplace installation must conform to the National Fuel Gas Code ANSI Z223.1 (in the United States) or the CAN/CGA-B149 Installation Codes (in Canada). The appliance must be electrically grounded in accordance with local codes or, in the absence of local codes with the National Electric Code ANSI/NFPA No. 70 (in the United States), or to the CSA C22.1 Canadian Electric Code (in Canada).

These models may be installed in a bedroom or bed-sitting room in the U.S.A. and Canada.

High Altitude Installations

U.L. Listed gas fireplaces are tested and approved for elevations from 0 to 2,000 feet in the U. S. A. and from 0 to 4,500 feet in Canada.

When installing this fireplace at an elevation above 2,000 feet (in the United States), it may be necessary to decrease the input rating by changing the existing burner orifice to a smaller size. Input should be reduced four percent (4%) for each 1,000 feet above sea level, unless the heating value of the gas has been reduced, in which case this general rule will not apply. To identify the proper orifice size, check with the local gas utility.

When installing this fireplace at an elevation between 2,000 and 4,500 feet (in Canada), the input rating must be reduced by ten percent (10%).

When installing this fireplace at an elevation above 4,500 feet (in Canada), check with local authorities.

Consult your local gas utility for assistance in determining the proper orifice for your location.

2

Getting Started

Introducing the Royal Fireplaces

Royal Fireplaces direct vent gas fireplaces are designed to operate with all combustion air siphoned from outside of the building and all exhaust gases expelled to the outside.

The information contained in this *Installers Guide*, unless noted otherwise, applies to all models and gas control systems.

Gas fireplace diagrams, including the dimensions, are shown in this section.

Pre-installation Preparation

This gas fireplace and its components are tested and safe when installed in accordance with this *Installers Guide*. Report to your dealer any parts damaged in shipment, particularly the condition of the glass. **Do not install any unit with damaged, incomplete, or substitute parts.**

The vent system components and trim doors are shipped in separate packages. The gas logs are packaged separately and must be field installed. **Read all of the instructions before starting the installation. Follow these instructions carefully during the installation to ensure maximum safety and benefit. Failure to follow these instructions will void the owner's warranty and may present a fire hazard.**

The Royal Fireplaces warranty will be voided by, and Hearth Technologies Inc. disclaims any responsibility for, the following actions:

- Installation of any damaged fireplace or vent system component.
- Modification of the fireplace or direct vent system.
- Installation other than as instructed by Hearth Technologies Inc.
- Improper positioning of the gas logs or the glass door.
- Installation and/or use of any component part not manufactured and approved by Hearth Technologies Inc. notwithstanding any independent testing laboratory or other party approval of such component part or accessory.

ANY SUCH ACTION MAY POSSIBLY CAUSE A FIRE HAZARD.

When planning a fireplace installation, it's necessary to determine:

- Where the unit is to be installed.
- The vent system configuration to be used.
- Gas supply piping.
- Electrical wiring.
- Framing and finishing details.
- Whether optional accessories—devices such as a fan, wall switch, or remote control—are desired.

If the fireplace is to be installed on carpeting or tile, or on any combustible material other than wood flooring, the fireplace should be installed on a metal or wood panel that extends the full width and depth of the fireplace.

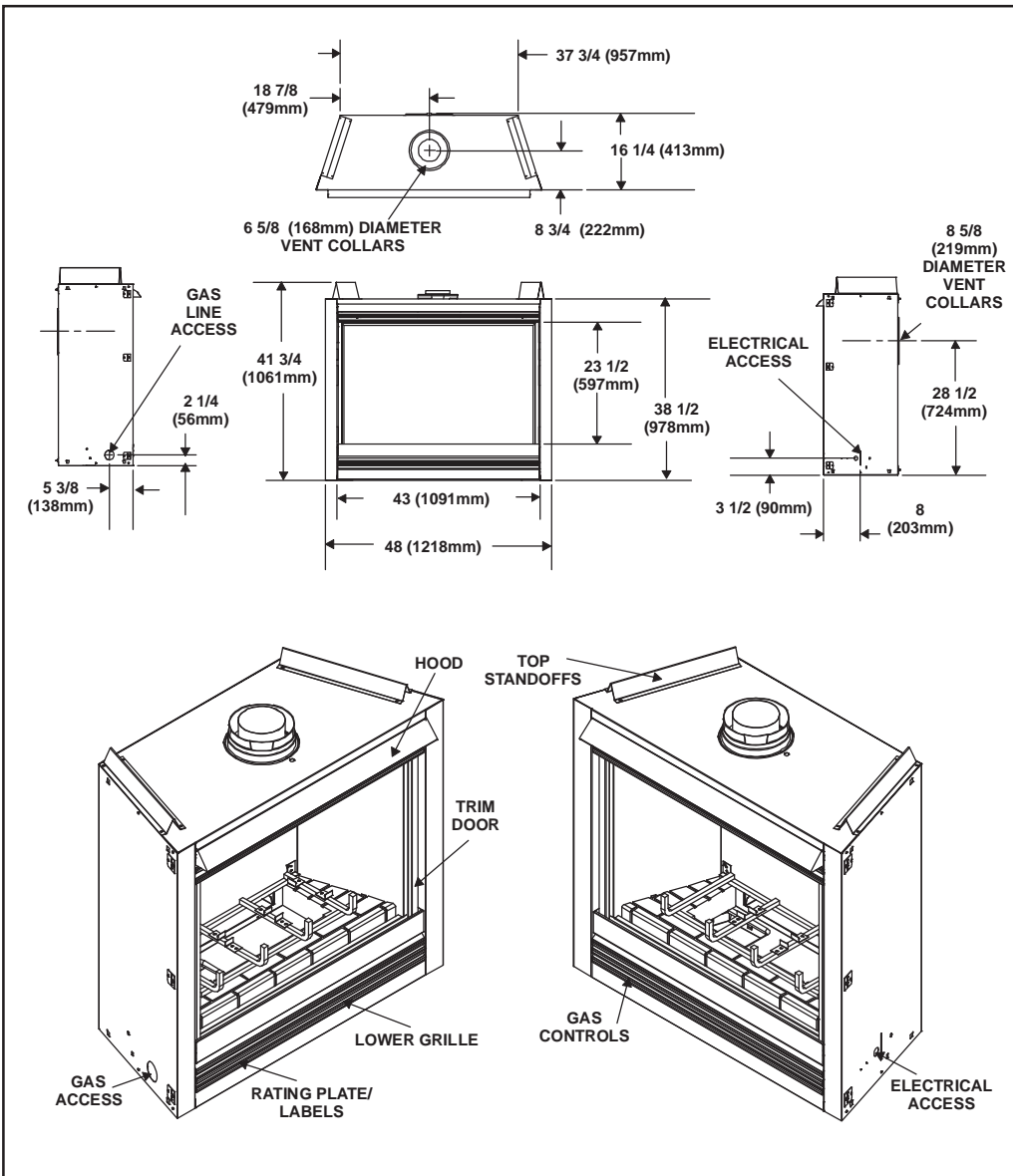

Figure 1. Diagram of the R-6500TR

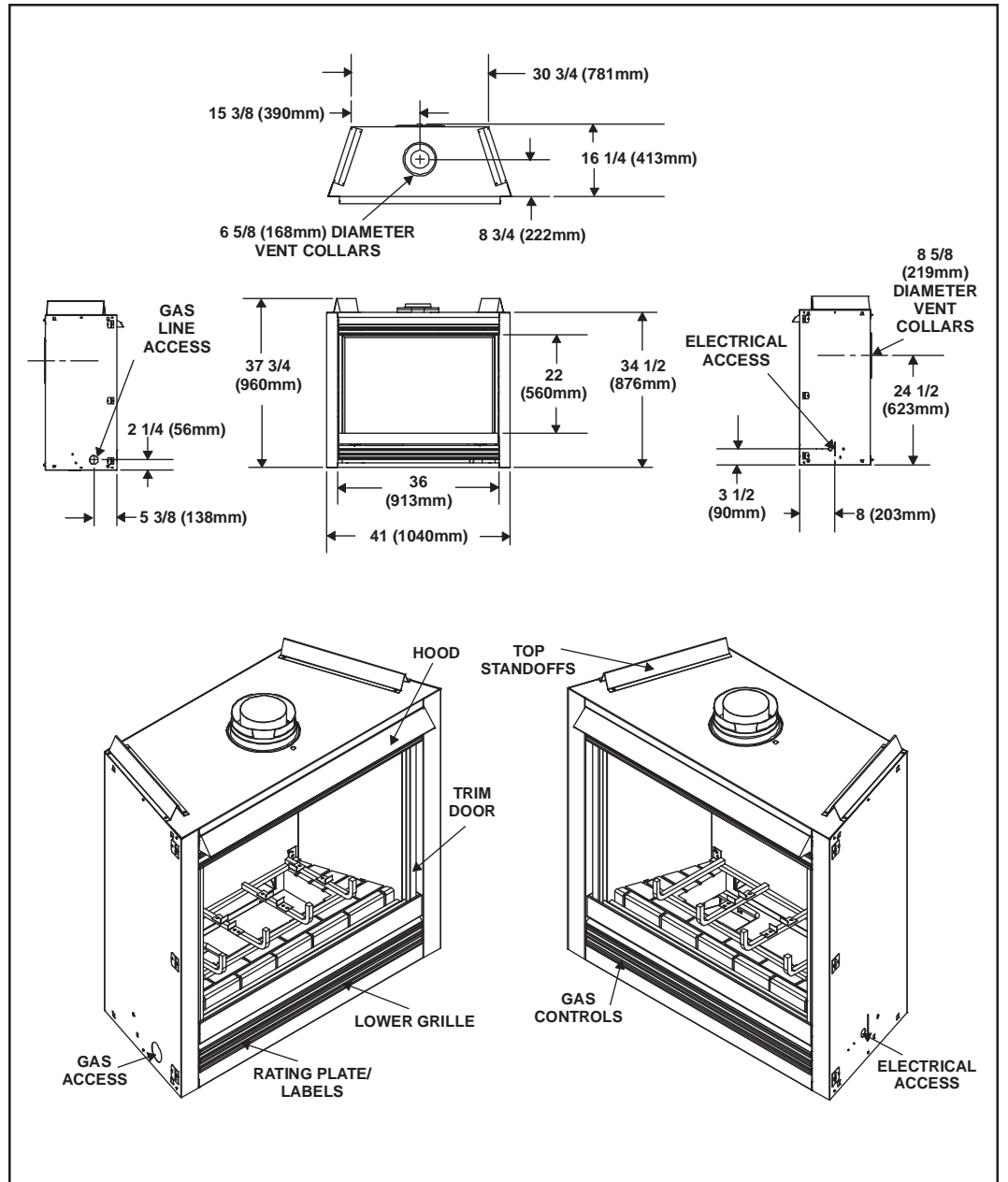

Figure 2. Diagram of the R-4500TR/TRH

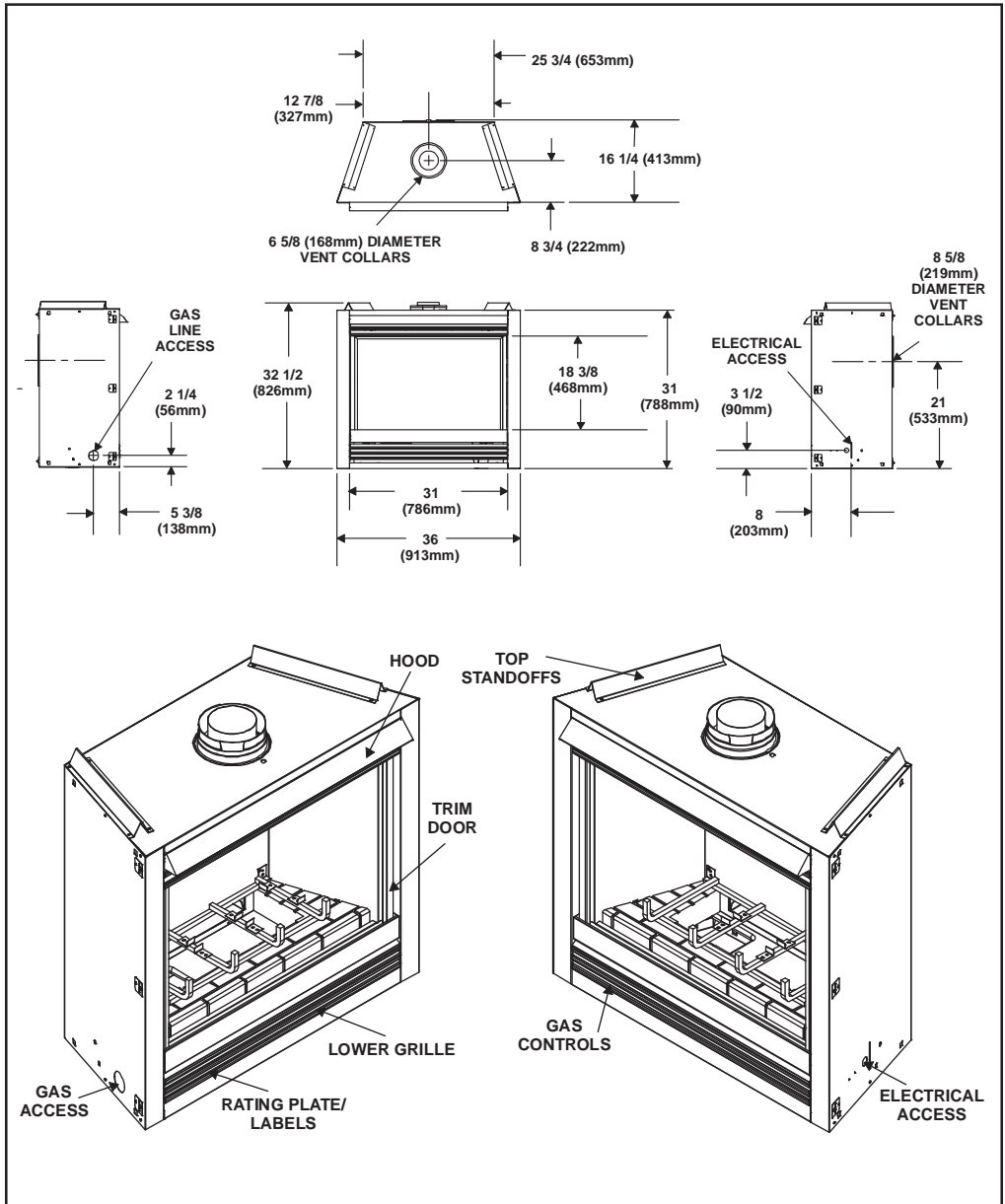

Figure 3. Diagram of the R-3500TR/TRH

3

Installing the Fireplace

Step 1 Locating the Fireplace

The diagram below shows space and clearance requirements for locating a fireplace within a room.

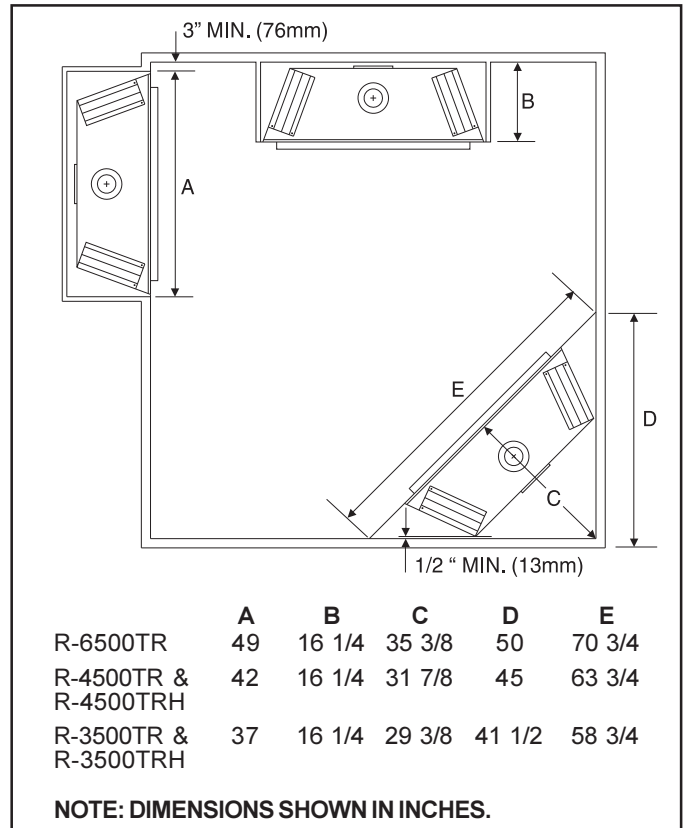

Figure 4. Fireplace Dimensions, Locations, and Space Requirements

Clearance Requirements

The top and back of the fireplace are defined by stand-offs.

Minimum Clearances from the Fireplace to Combustible Materials					
Glass Front	Floor	Back of Fireplace	Sides of Fireplace	Top of Fireplace	Ceiling*
36 inches (914 mm)	0	1/2 inch (13mm)	1/2 inch (13mm)	R-3500TR & R-3500TRH: 1 1/2" (38mm) R-4500TR & R-4500TRH: 3 1/4" (83mm) R-6500TR: 3 1/4" (83mm)	31 inches (787mm)

*The clearance to the ceiling is measured from the top of the unit, excluding the standoffs and collar. (see Figure 42).

The minimum clearance to a perpendicular wall extending past the face of the fireplace is 3 inches (76.2mm).

The back of the fireplaces may be recessed into combustible construction, as shown below.

MODELS	RECESSED DEPTH
R-6500TR, R-4500TR & R-4500TRH, R-3500TR & R-3500TRH	16 1/4

Minimum Clearances from the Vent Pipe to Combustible Materials						
For Horizontal Sections			For Vertical Sections	At Wall Firestops		
Top	Bottom	Sides	1 inch (25 mm)	Top	Bottom	Sides
3 inches (75 mm)	1 inch (25 mm)	1 inch (25 mm)			2-1/2 inches (63.7 mm)	1/2 inch (13 mm)

For minimum clearances, see the direct vent termination clearance diagrams on pages 38 and 40 in this section.

Step 2 Framing the Fireplace

Fireplace framing can be built before or after the fireplace is set in place. Framing should be positioned to accommodate wall coverings and fireplace facing material. The diagram below shows framing reference dimensions.

CAUTION

MEASURE FIREPLACE DIMENSIONS, AND VERIFY FRAMING METHODS AND WALL COVERING DETAILS, BEFORE FRAMING CONSTRUCTION BEGINS.

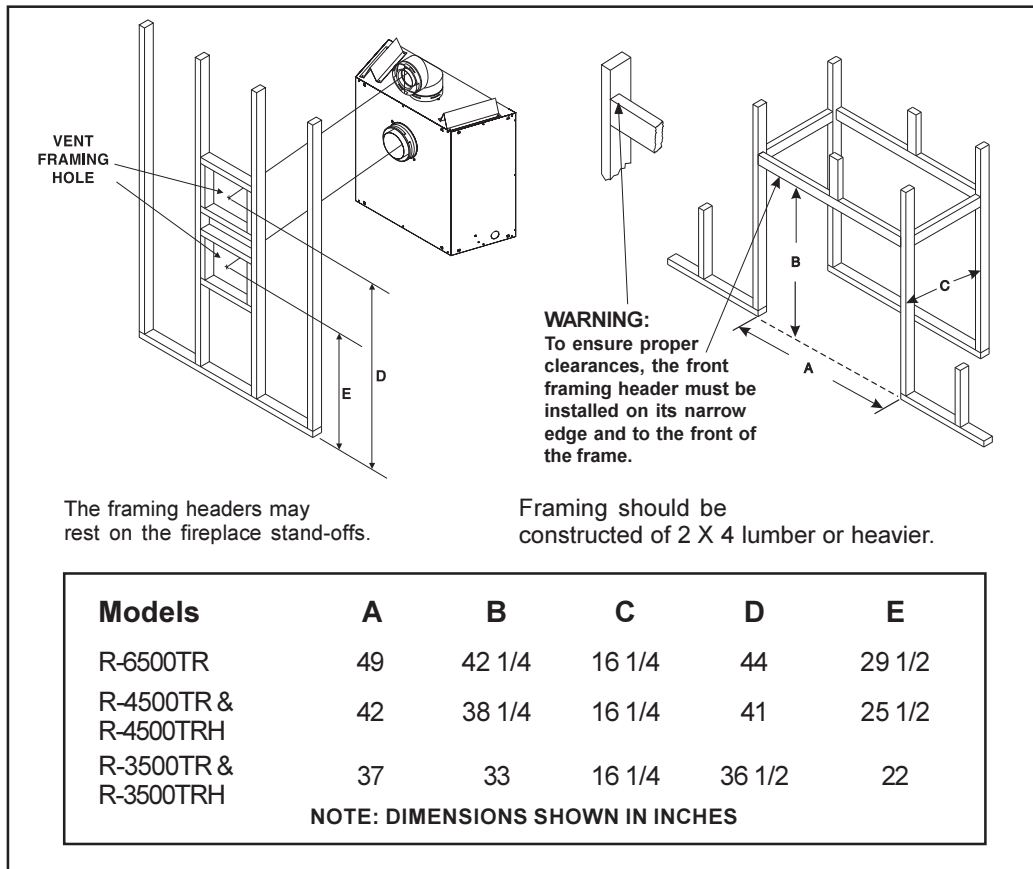

Figure 5. Framing Dimensions

Step 3 Installing the Vent System

A. Vent System Approvals

These models have vent starting collars on both the top and the back of the unit. Depending upon the installation, decide which ONE set of starting collars will be used to attached the vent system. The starting collar sealing cap must remain on the starting collar NOT used.

These models use SL-D-series, direct vent components when using the **TOP** vent collars and D-series direct vent components when using the **REAR** vent collars.

The flame and ember appearance may vary based on the type of fuel burned and the venting configuration used.



WARNING: YOU MUST NOT MIX D-SERIES AND SL D-SERIES COMPONENTS IN ANY VENT SYSTEM CONFIGURATION.

Identifying Vent Components

Approved vent system components are labeled for identification. **NO OTHER VENTING SYSTEMS OR COMPONENTS MAY BE USED.** This pipe is tested and listed as an approved component of the fireplace. There is no requirement for inspection openings at each joint within the wall. The pipe is tested to be run inside an enclosed wall. There is no required pitch for horizontal vent runs. Detailed installation instructions are included with each vent termination kit and should be used in conjunction with this *Installers Guide*. Figure 6 shows vent system components and terminations.

The vent systems installed on this gas fireplace may include one, two, or three 90° elbow assemblies. The relationships of vertical rise to horizontal run in vent configurations using 90° elbows **MUST BE** strictly adhered to. The rise to run relationships are shown in the venting drawings and tables on the next several pages.

NOTE: Two 45° elbows may be used in place of one 90° elbow. You **MUST** always maintain the **MAXIMUM** and **MINIMUM** rise-to-run ratios in the vent system when using 45° elbows.

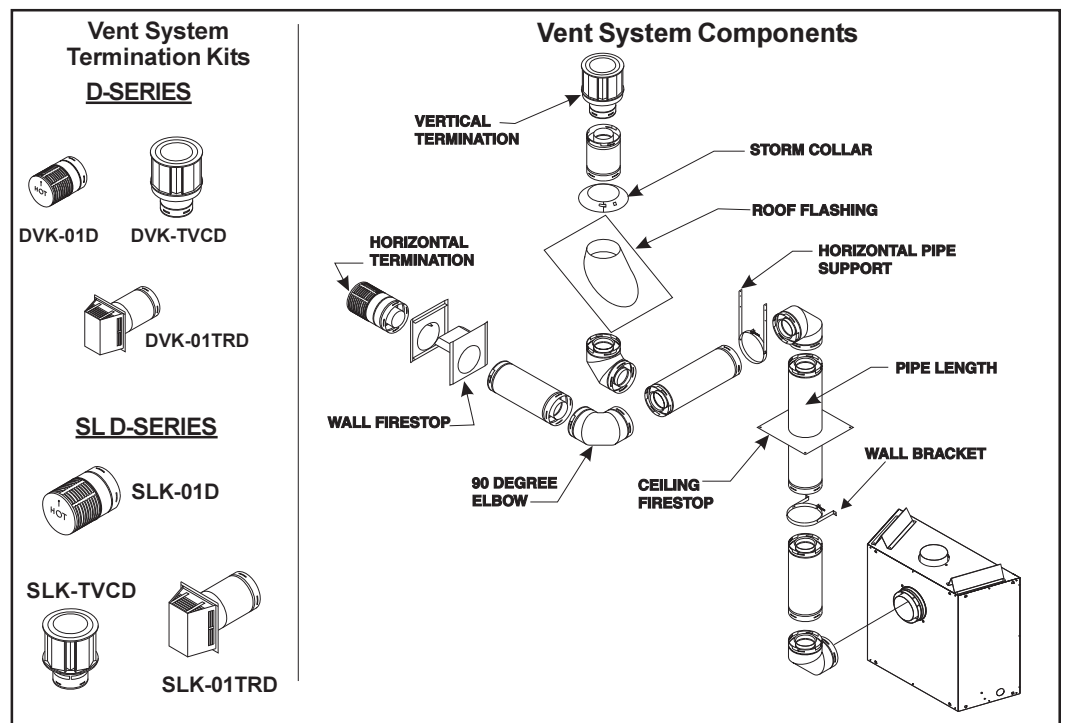
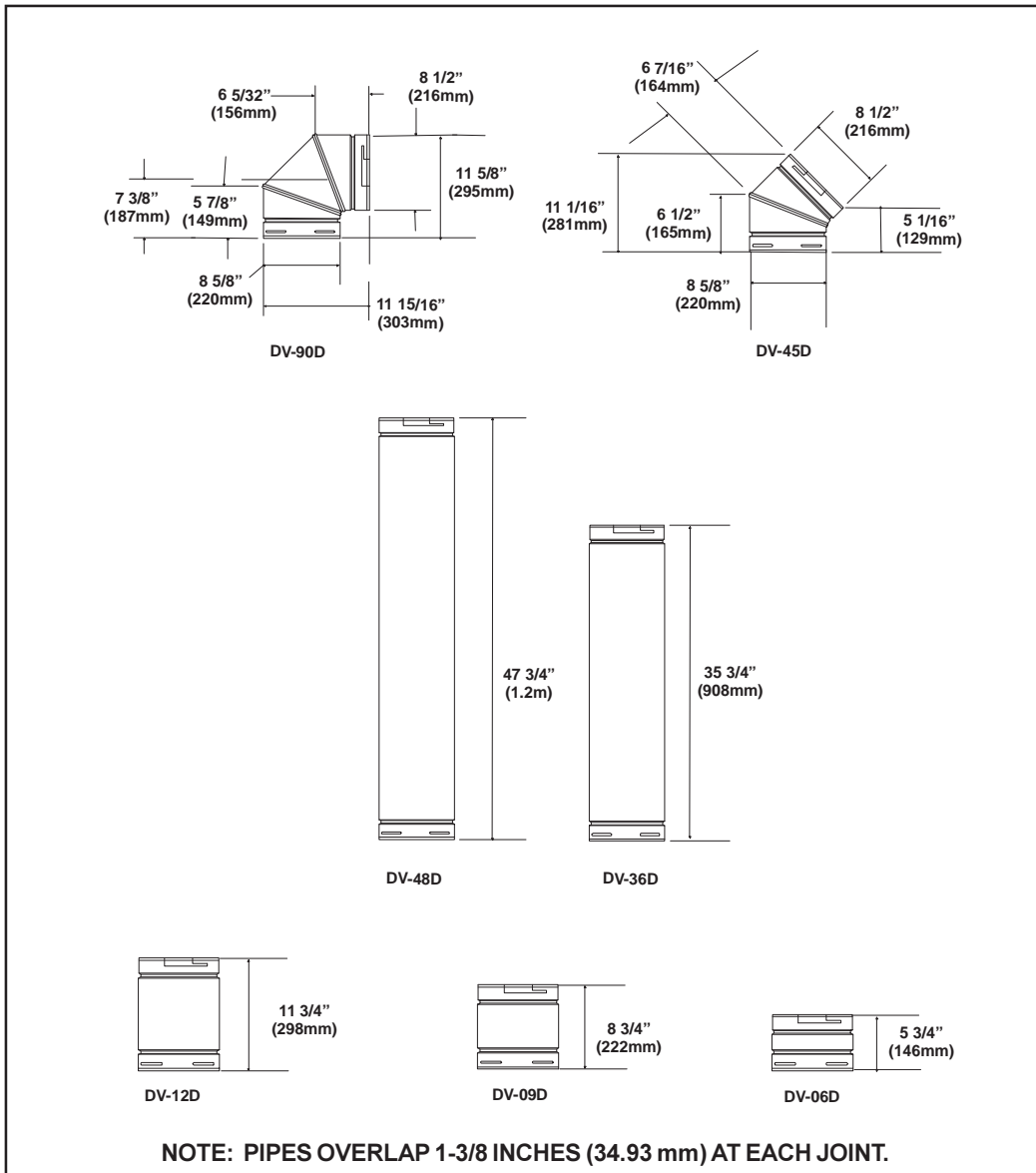

Figure 6. Vent Components and Terminations



**Figure 7. D-Series Direct Vent Component Specifications
(5-inch inner pipe / 8 5/8-inch outer pipe)**

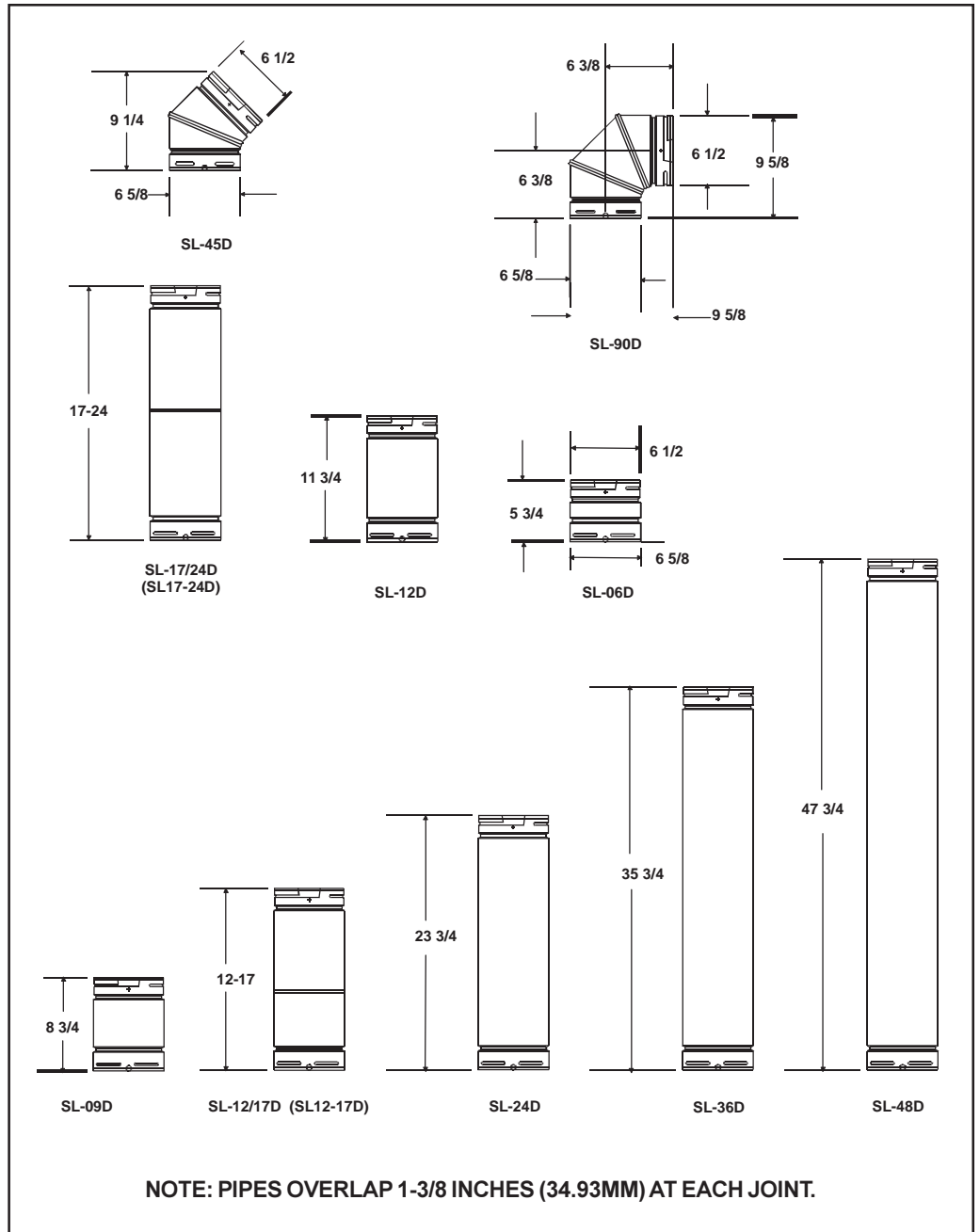

Figure 8. SL D-Series Direct Vent Component Specifications (4-inch inner pipe / $6 \frac{5}{8}$ -inch outer pipe)

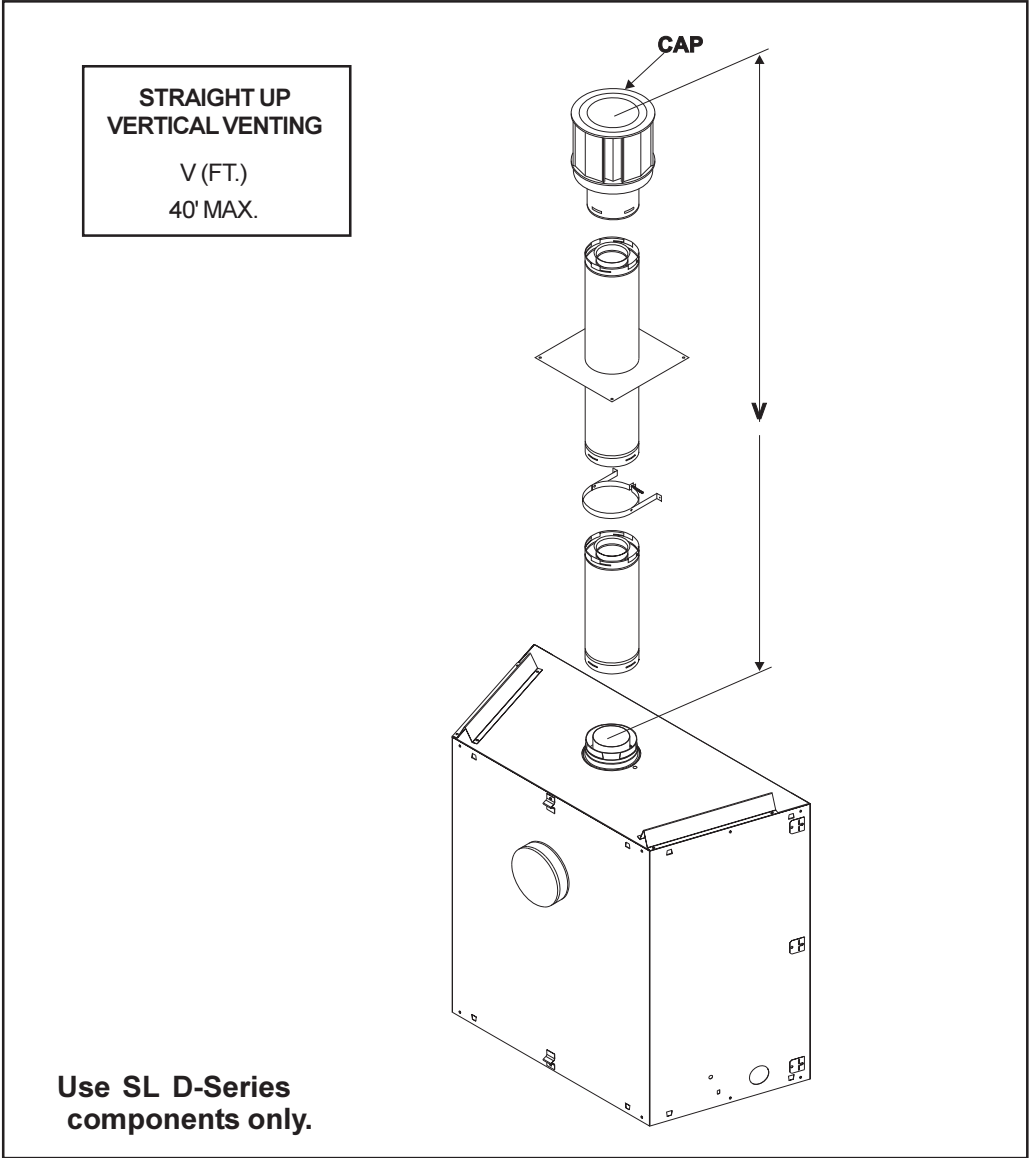

Figure 9. Straight up Vertical Venting

NOTE: For vertical venting over 20 feet a restrictor plate is recommended for improved flame appearance. See accessories page for kit number. Instructions are provided in the kit.

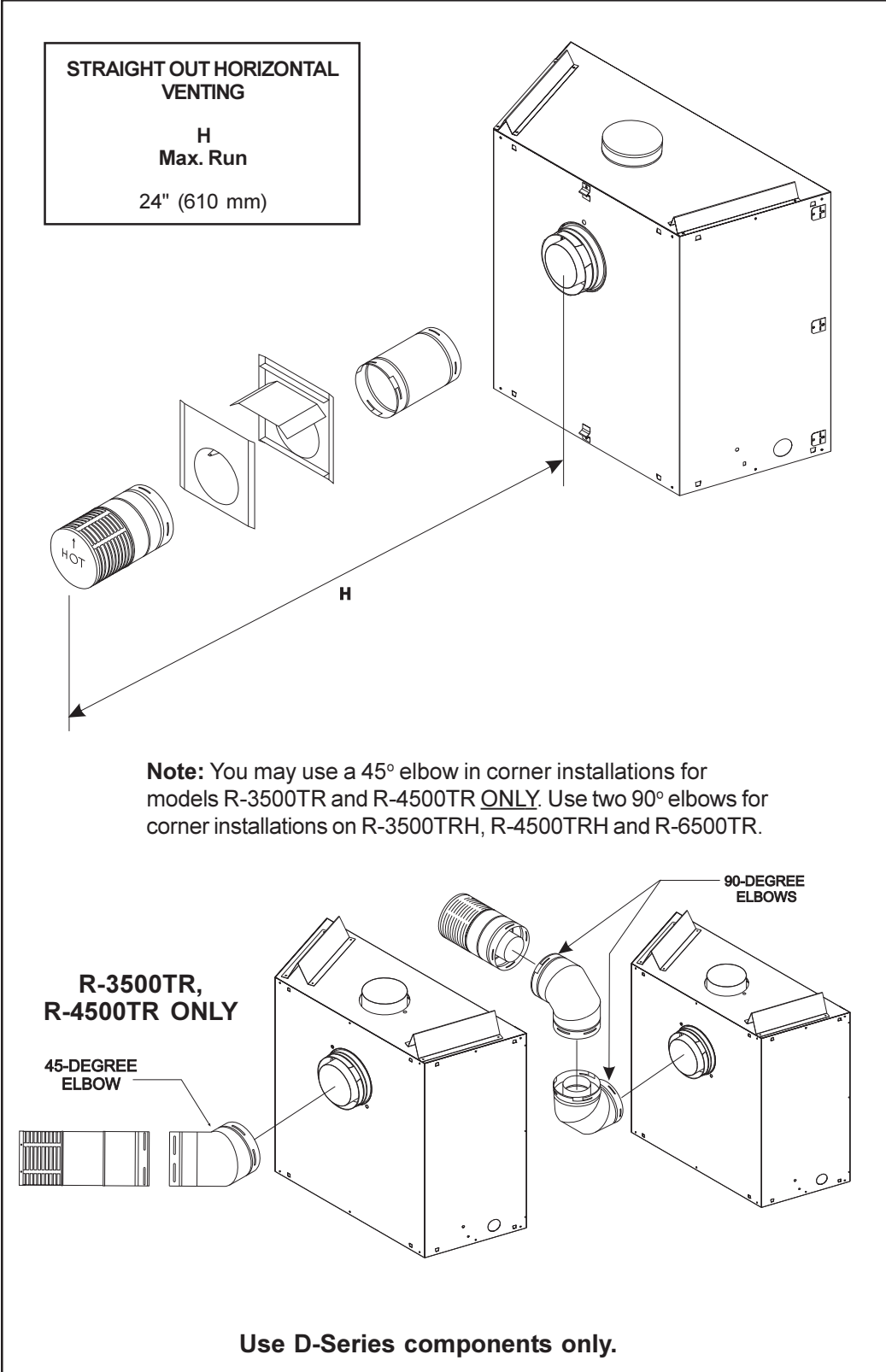

Figure 10. Straight Out Horizontal Venting

VENTING WITH ONE (1) 90° ELBOW

V (FT.)

- 1' MIN. (305mm)
- 2' MIN. (610mm)
- 3' MIN. (914mm)
- 4' MIN. (1.22m)

H (FT.)

- 2' MAX. (610mm)
- 4' MAX. (1.22m)
- 6' MAX. (1.86m)
- 8' MAX. (2.48m)

V+H = 40' MAX. (12.2m) H = 8' MAX. (2.48m)

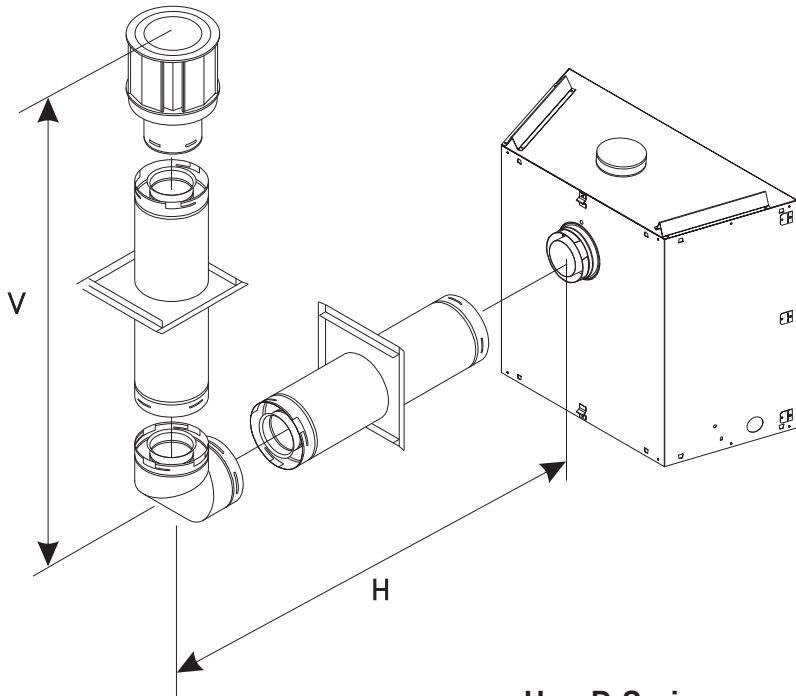

Use D-Series components only.

Figure 11. Venting with One 90° Elbow

VENTING WITH ONE (1) 90° ELBOW NATURAL GAS

V (MIN.)	MODEL R-3500TR H (MAX.)	MODEL R-4500TR H (MAX.)	MODEL R-6500TR H (MAX.)
90° Elbow on Top	3 FT (914mm)	2.5 FT (863mm)	2 FT (610mm)
1 FT (305mm)	3 FT (914mm)	3 FT (914mm)	3 FT (914mm)
2 FT (610mm)	4 FT (1.22m)	4 FT (1.22m)	4 FT (1.22m)
3 FT (914mm)	6 FT (1.86m)	6 FT (1.86m)	6 FT (1.86m)
4 FT (1.22m)	8 FT (2.48m)	8 FT (2.48m)	8 FT (2.48m)
5 FT (1.52m)	16 FT (4.8m)	16 FT (4.8m)	16 FT (4.8m)
H MAX. = 16 FT (4.8m)		V + H MAX. = 40 FT (12.2m)	

VENTING WITH ONE (1) 90° ELBOW PROPANE

V (MIN.)	MODEL R-3500TR H (MAX.)	MODEL R-4500TR H (MAX.)	MODEL R-6500TR H (MAX.)
90° Elbow on Top	3 FT (914mm)	2.5 FT (863mm)	NOT ALLOWED
1 FT (305mm)	3 FT (914mm)	3 FT (914mm)	2 FT (610mm)
2 FT (610mm)	4 FT (1.22m)	4 FT (1.22m)	4 FT (1.22m)
3 FT (914mm)	6 FT (1.86m)	6 FT (1.86m)	6 FT (1.86m)
4 FT (1.22m)	8 FT (2.48m)	8 FT (2.48m)	8 FT (2.48m)
5 FT (1.52m)	16 FT (4.8m)	16 FT (4.8m)	16 FT (4.8m)
H MAX. = 16 FT (4.8m)		V + H MAX. = 40 FT (12.2m)	

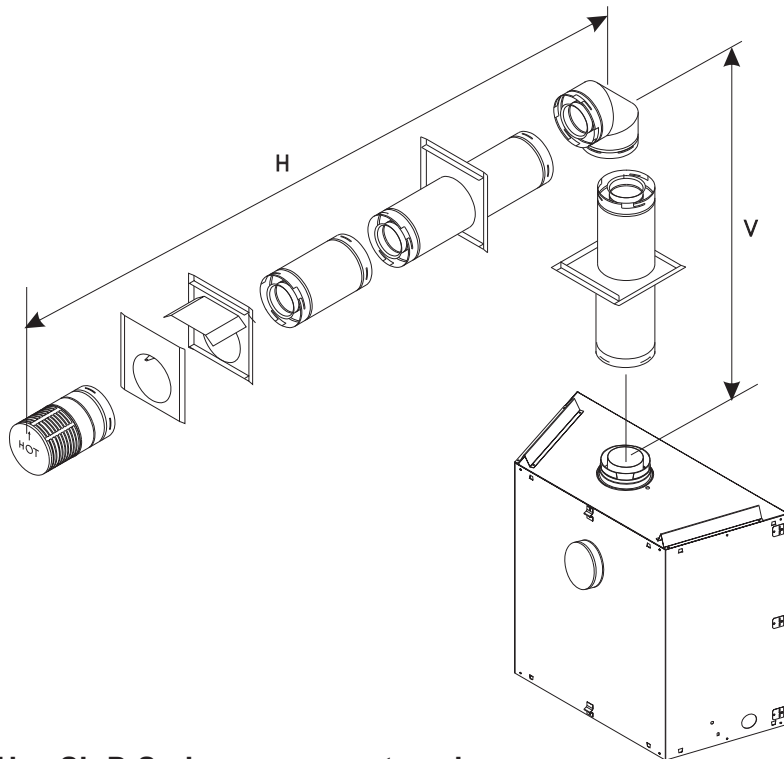

Use SL D-Series components only.

Figure 12. Venting with One 90° Elbow - TR MODELS

VENTING WITH ONE (1) 90° ELBOW		NATURAL GAS
V (MIN.)	MODEL R-3500TRH	MODEL R-4500TRH
90° Elbow on Top	H (MAX.)	H (MAX.)
1 FT (305mm)	2 FT (610mm)	2 FT (610mm)
2 FT (610mm)	3 FT (914mm)	3 FT (914mm)
3 FT (914mm)	4 FT (1.22m)	4 FT (1.22m)
4 FT (1.22m)	6 FT (1.86m)	6 FT (1.86m)
5 FT (1.52m)	8 FT (2.48m)	8 FT (2.48m)
	16 FT (4.8m)	16 FT (4.8m)
H MAX. = 16 FT (4.8m)		V + H MAX. = 40 FT (12.2m)

VENTING WITH ONE (1) 90° ELBOW		PROPANE
V (MIN.)	MODEL R-3500TRH	MODEL R-4500TRH
90° Elbow on Top	H (MAX.)	H (MAX.)
1 FT (305mm)	NOT ALLOWED	NOT ALLOWED
2 FT (610mm)	2 FT (610mm)	2 FT (610mm)
3 FT (914mm)	4 FT (1.22m)	4 FT (1.22m)
4 FT (1.22m)	6 FT (1.86m)	6 FT (1.86m)
5 FT (1.52m)	8 FT (2.48m)	8 FT (2.48m)
	16 FT (4.8m)	16 FT (4.8m)
H MAX. = 16 FT (4.8m)		V + H MAX. = 40 FT (12.2m)

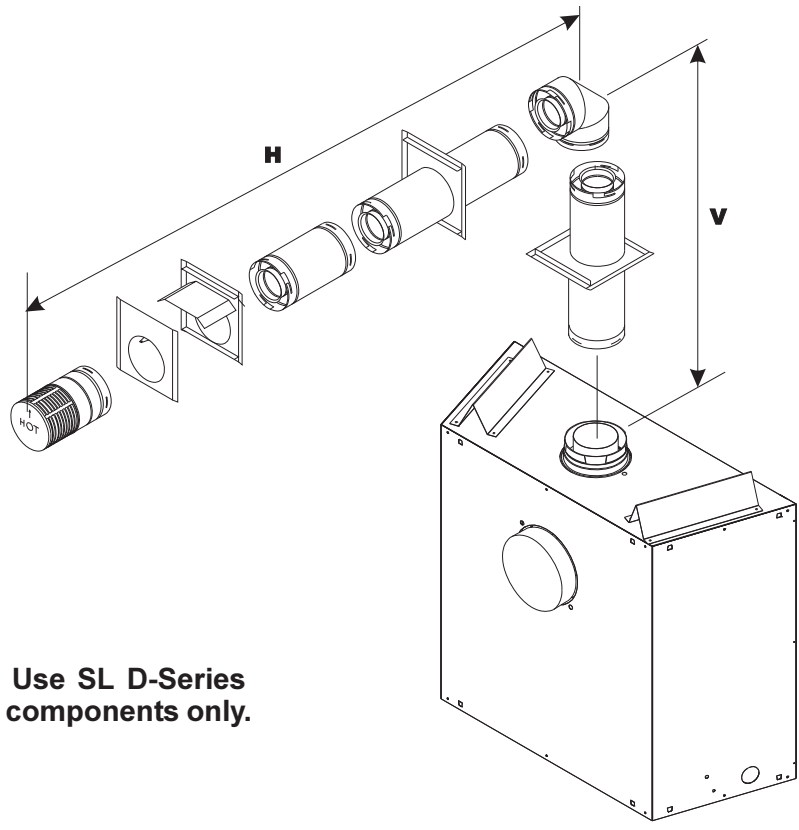

Figure 13. Venting with One 90° Elbow - TRH MODELS

VENTING WITH TWO (2) 90° ELBOWS

V	H	H + H ₁
1' MIN. (305 mm)	2' MAX. (610 mm)	4' MAX. (1.22 m)
2' MIN. (610 mm)	4' MAX. (1.22 m)	8' MAX. (2.4 m)
3' MIN. (914 mm)	6' MAX. (1.86 m)	12' MAX. (3.6 m)
4' MIN. (1.22 m)	8' MAX. (2.48 m)	16' MAX. (4.8 m)

H = 8' MAX. (2.48 m) H + H₁ = 16' MAX. (4.8 m)

V + H + H₁ = 40' (12.2m) MAX.

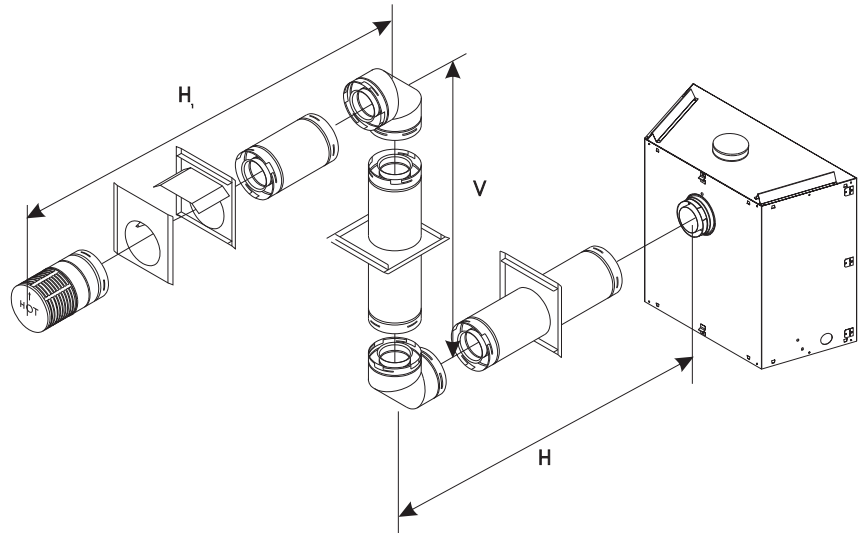

Use D-Series components only.

VENTING WITH TWO (2) 90° ELBOWS

V (FT)	H + H ₁ (FT)
1' MIN. (305 mm)	2' MAX. (610 mm)
2' MIN. (610 mm)	4' MAX. (1.22 m)
3' MIN. (914 mm)	6' MAX. (1.86 m)
4' MIN. (1.22 m)	8' MAX. (2.48 m)

H + H₁ = 8' MAX. (2.48 m)

V + H + H₁ = 40' (12.2m) MAX.

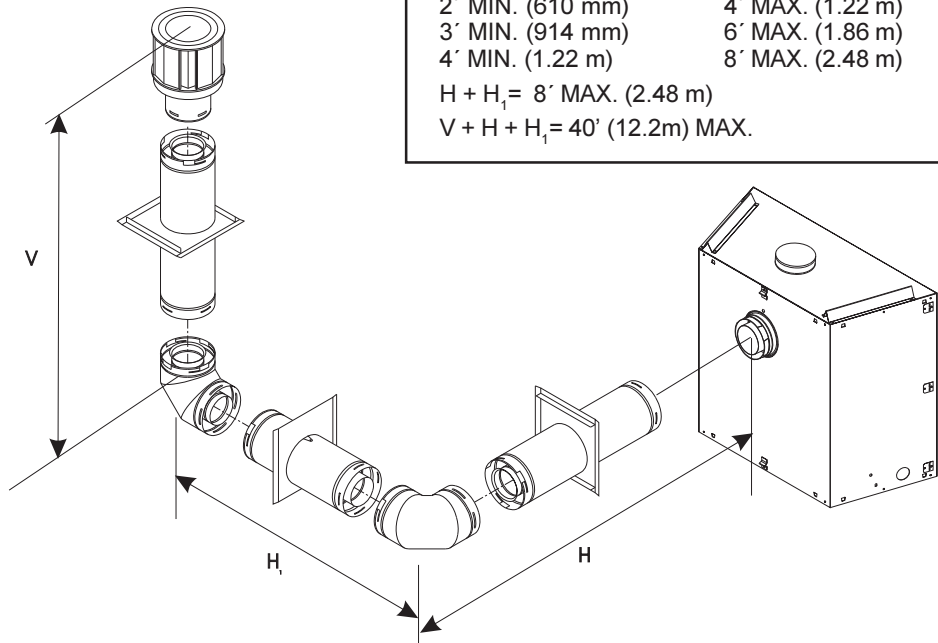

Figure 14. Venting with Two 90° Elbows

VENTING WITH TWO (2) 90° ELBOWS NATURAL GAS

	MODEL R-3500TR	MODEL R-4500TR	MODEL R-6500TR
V (MIN.)	H + H₁ (MAX.)	H + H₁ (MAX.)	H + H₁ (MAX.)
90° Elbow on Top	3 FT (914mm)	2.5 FT (863mm)	2 FT (610mm)
1 FT (305mm)	3 FT (914mm)	3 FT (914mm)	3 FT (914mm)
2 FT (610mm)	4 FT (1.22m)	4 FT (1.22m)	4 FT (1.22m)
3 FT (914mm)	6 FT (1.86m)	6 FT (1.86m)	6 FT (1.86m)
4 FT (1.22m)	8 FT (2.48m)	8 FT (2.48m)	8 FT (2.48m)
5 FT (1.52m)	16 FT (4.8m)	16 FT (4.8m)	16 FT (4.8m)
H + H ₁ MAX. = 16 FT (4.8m)		V + H + H ₁ MAX. = 40 FT (12.2m)	

VENTING WITH TWO (2) 90° ELBOWS PROPANE

	MODEL R-3500TR	MODEL R-4500TR	MODEL R-6500TR
V (MIN.)	H + H₁ (MAX.)	H + H₁ (MAX.)	H + H₁ (MAX.)
90° Elbow on Top	3 FT (914mm)	2.5 FT (863mm)	NOT ALLOWED
1 FT (305mm)	3 FT (914mm)	3 FT (914mm)	2 FT (610mm)
2 FT (610mm)	4 FT (1.22m)	4 FT (1.22m)	4 FT (1.22m)
3 FT (914mm)	6 FT (1.86m)	6 FT (1.86m)	6 FT (1.86m)
4 FT (1.22m)	8 FT (2.48m)	8 FT (2.48m)	8 FT (2.48m)
5 FT (1.52m)	16 FT (4.8m)	16 FT (4.8m)	16 FT (4.8m)
H + H ₁ MAX. = 16 FT (4.8m)		V + H + H ₁ MAX. = 40 FT (12.2m)	

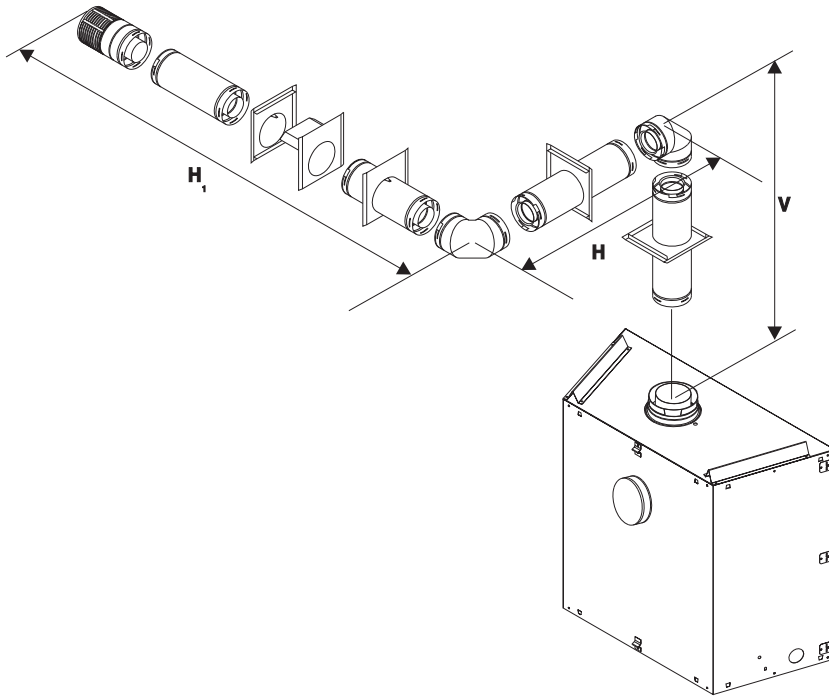
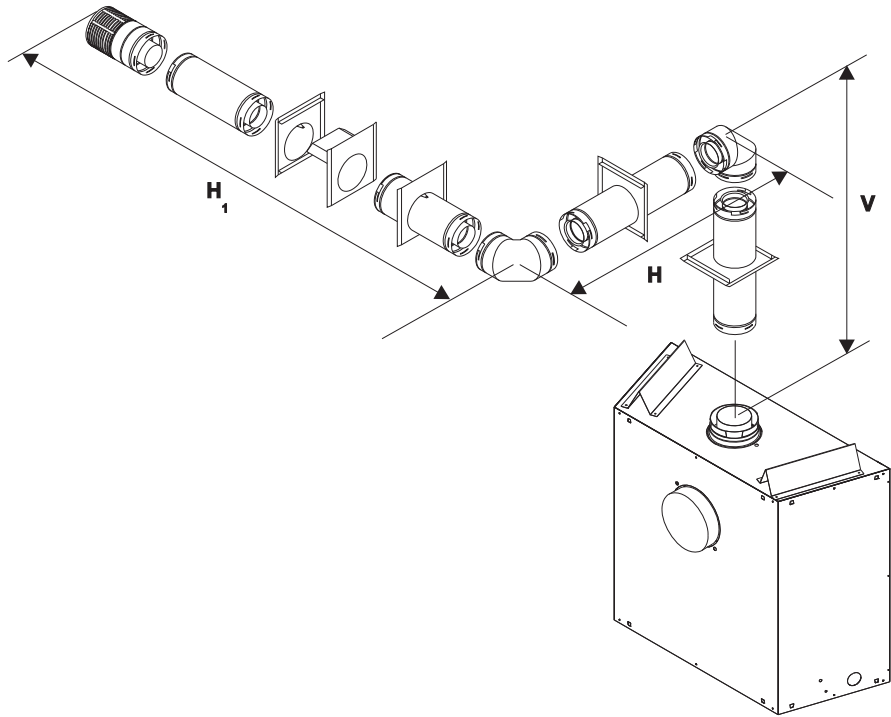

Figure 15. Venting with Two 90° Elbows - TR MODELS

VENTING WITH TWO (2) 90° ELBOWS		NATURAL GAS
V (MIN.)	MODEL R-3500TRH	MODEL R-4500TRH
90° Elbow on Top	H + H ₁ (MAX.)	H + H ₁ (MAX.)
1 FT (305mm)	2 FT (610mm)	2 FT (610mm)
2 FT (610mm)	3 FT (914mm)	3 FT (914mm)
3 FT (914mm)	4 FT (1.22m)	4 FT (1.22m)
4 FT (1.22m)	6 FT (1.86m)	6 FT (1.86m)
5 FT (1.52m)	8 FT (2.48m)	8 FT (2.48m)
	16 FT (4.8m)	16 FT (4.8m)
H + H ₁ MAX. = 16 FT (4.8m)		V + H + H ₁ MAX. = 40 FT (12.2m)

VENTING WITH TWO (2) 90° ELBOWS		PROPANE
V (MIN.)	MODEL R-3500TRH	MODEL R-4500TRH
90° Elbow on Top	H + H ₁ (MAX.)	H + H ₁ (MAX.)
1 FT (305mm)	NOT ALLOWED	NOT ALLOWED
2 FT (610mm)	2 FT (610mm)	2 FT (610mm)
3 FT (914mm)	4 FT (1.22m)	4 FT (1.22m)
4 FT (1.22m)	6 FT (1.86m)	6 FT (1.86m)
5 FT (1.52m)	8 FT (2.48m)	8 FT (2.48m)
	16 FT (4.8m)	16 FT (4.8m)
H + H ₁ MAX. = 16 FT (4.8m)		V + H + H ₁ MAX. = 40 FT (12.2m)



Use SL D-Series components only.

Figure 16. Venting with Two 90° Elbows - TRH MODELS

VENTING WITH TWO (2) 90° ELBOWS NATURAL GAS

V (MIN.)	MODEL R-3500TR H (MAX.)	MODEL R-4500TR H (MAX.)	MODEL R-6500TR H (MAX.)
90° Elbow on Top	3 FT (914mm)	2.5 FT (863mm)	2 FT (610mm)
1 FT (305mm)	3 FT (914mm)	3 FT (914mm)	3 FT (914mm)
2 FT (610mm)	4 FT (1.22m)	4 FT (1.22m)	4 FT (1.22m)
3 FT (914mm)	6 FT (1.86m)	6 FT (1.86m)	6 FT (1.86m)
4 FT (1.22m)	8 FT (2.48m)	8 FT (2.48m)	8 FT (2.48m)
5 FT (1.52m)	16 FT (4.8m)	16 FT (4.8m)	16 FT (4.8m)
H MAX. = 16 FT (4.8m)		V + V ₁ + HMAX. = 40 FT (12.2m)	

VENTING WITH TWO (2) 90° ELBOWS PROPANE

V (MIN.)	MODEL R-3500TR H (MAX.)	MODEL R-4500TR H (MAX.)	MODEL R-6500TR H (MAX.)
90° Elbow on Top	3 FT (914mm)	2.5 FT (863mm)	NOT ALLOWED
1 FT (305mm)	3 FT (914mm)	3 FT (914mm)	2 FT (610mm)
2 FT (610mm)	4 FT (1.22m)	4 FT (1.22m)	4 FT (1.22m)
3 FT (914mm)	6 FT (1.86m)	6 FT (1.86m)	6 FT (1.86m)
4 FT (1.22m)	8 FT (2.48m)	8 FT (2.48m)	8 FT (2.48m)
5 FT (1.52m)	16 FT (4.8m)	16 FT (4.8m)	16 FT (4.8m)
H MAX. = 16 FT (4.8m)		V + V ₁ + HMAX. = 40 FT (12.2m)	

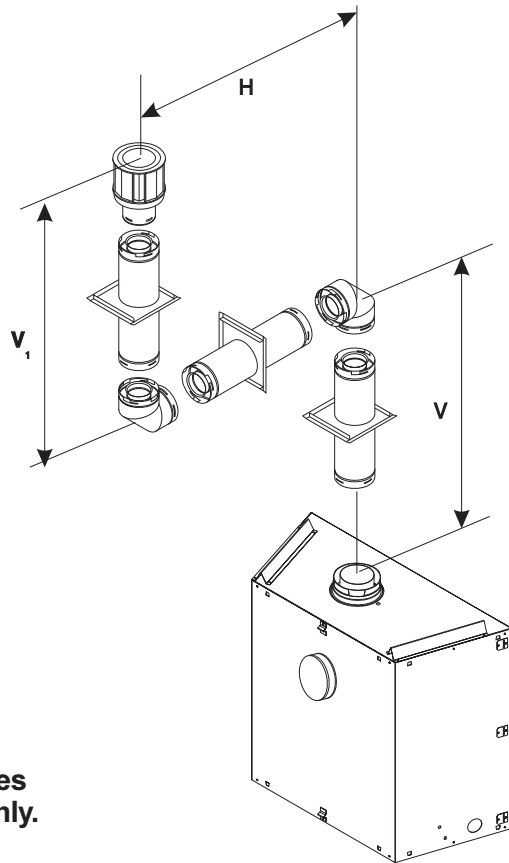

Use SL D-Series components only.

Figure 17. Venting with Two 90° Elbows - TR MODELS

VENTING WITH TWO (2) 90° ELBOWS		NATURAL GAS
V (MIN.)	MODEL R-3500TRH	MODEL R-4500TRH
90° Elbow on Top	H (MAX.)	H (MAX.)
1 FT (305mm)	2 FT (610mm)	2 FT (610mm)
2 FT (610mm)	3 FT (914mm)	3 FT (914mm)
3 FT (914mm)	4 FT (1.22m)	4 FT (1.22m)
4 FT (1.22m)	6 FT (1.86m)	6 FT (1.86m)
5 FT (1.52m)	8 FT (2.48m)	8 FT (2.48m)
	16 FT (4.8m)	16 FT (4.8m)
H MAX. = 16 FT (4.8m)		V + V ₁ + H MAX. = 40 FT (12.2m)

VENTING WITH TWO (2) 90° ELBOWS		PROPANE
V (MIN.)	MODEL R-3500TRH	MODEL R-4500TRH
90° Elbow on Top	H (MAX.)	H (MAX.)
1 FT (305mm)	NOT ALLOWED	NOT ALLOWED
2 FT (610mm)	2 FT (610mm)	2 FT (610mm)
3 FT (914mm)	4 FT (1.22m)	4 FT (1.22m)
4 FT (1.22m)	6 FT (1.86m)	6 FT (1.86m)
5 FT (1.52m)	8 FT (2.48m)	8 FT (2.48m)
	16 FT (4.8m)	16 FT (4.8m)
H MAX. = 16 FT (4.8m)		V + V ₁ + H MAX. = 40 FT (12.2m)

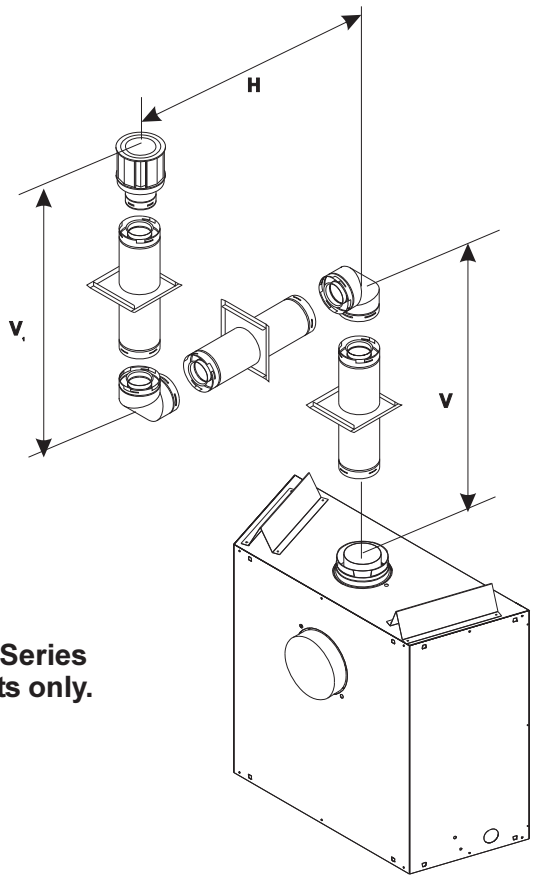

Use SL D-Series components only.

Figure 18. Venting with Two 90° Elbows - TRH MODELS

VENTING WITH THREE (3) 90° ELBOWS		
V (FT.)	H (FT.)	H + H ₁ (FT.)
1' MIN. (305 mm)	2' MAX. (610 mm)	4' MAX. (1.22 m)
2' MIN. (610 mm)	4' MAX. (1.22 m)	8' MAX. (2.48 m)
3' MIN. (914 mm)	6' MAX. (1.86 m)	12' MAX. (3.72 m)
4' MIN. (1.22 m)	8' MAX. (2.48 m)	16' MAX. (4.8 m)
	H = 8' MAX. (2.48 m)	16' MAX. (4.8 m)
NOTE: V + V ₁ + H + H ₁ = 40' (12.2m) MAX.		

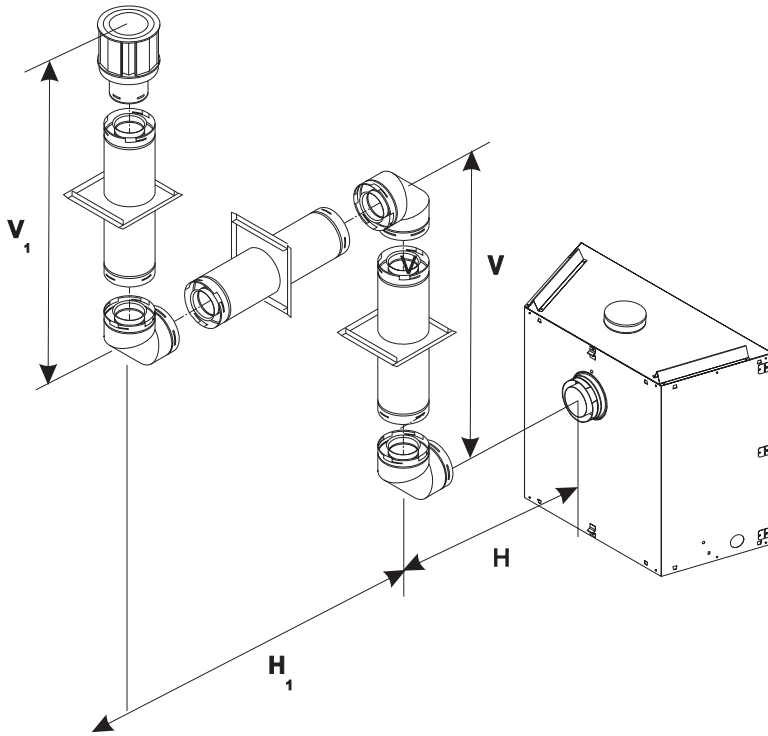

VENTING WITH THREE (3) 90° ELBOWS		
V (FT.)	H (FT.)	H + H ₁ + H ₂ (FT.)
1' MIN. (305 mm)	2' MAX. (610 mm)	4' MAX. (1.22 m)
2' MIN. (610 mm)	4' MAX. (1.22 m)	8' MAX. (2.48 m)
3' MIN. (914 mm)	6' MAX. (1.86 m)	12' MAX. (3.7 m)
4' MIN. (1.22 m)	8' MAX. (2.48 m)	16' MAX. (4.8 m)
V + H + H ₁ + H ₂ = 40' (12.2m) MAX. H = 8' MAX. (2.48m) H + H ₁ + H ₂ = 16' MAX. (4.8m)		

Use D-Series components only.

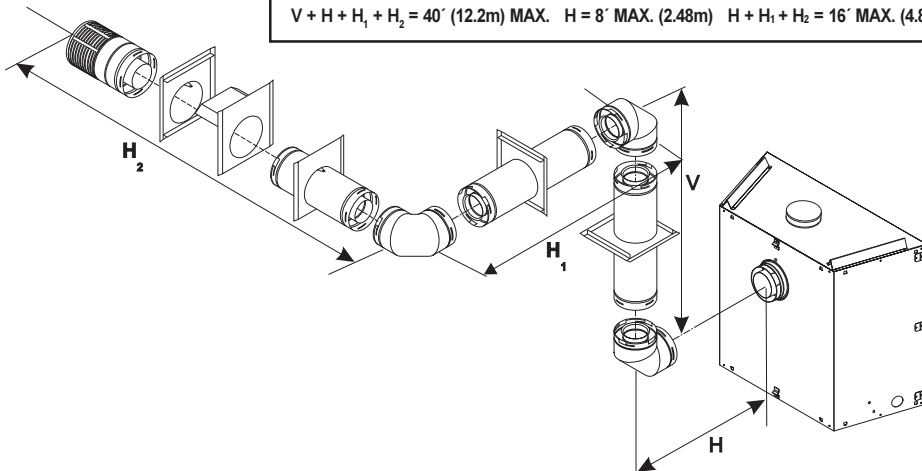

Figure 19. Venting with three 90° elbows

VENTING WITH THREE (3) 90° ELBOWS NATURAL GAS

V (MIN.)	MODEL R-3500TR		MODEL R-4500TR		MODEL R-6500TR	
	H (MAX.)	H + H ₁ (MAX.)	H (MAX.)	H + H ₁ (MAX.)	H (MAX.)	H + H ₁ (MAX.)
90° Elbow on Top	3FT (914mm)	4FT (1.22m)	2.5FT (863mm)	4FT (1.22m)	2FT (610mm)	4FT (1.22m)
1FT (305mm)	3FT (914mm)	6FT (1.86m)	3FT (914mm)	6FT (1.86m)	3FT (914mm)	6FT (1.86m)
2FT (610mm)	4FT (1.22m)	8FT (2.48m)	4FT (1.22m)	8FT (2.48m)	4FT (1.22m)	8FT (2.48m)
3FT (914mm)	6FT (1.86m)	12FT (3.72m)	6FT (1.86m)	12FT (3.72m)	6FT (1.86m)	12FT (3.72m)
4FT (1.22m)	8FT (2.48m)	16FT (4.8m)	8FT (2.48m)	16FT (4.8m)	8FT (2.48m)	16FT (4.8m)
5FT (1.52m)	16FT (4.8m)	16FT (4.8m)	16FT (4.8m)	16FT (4.8m)	16FT (4.8m)	16FT (4.8m)

$V + H + V_1 + H_1 \text{ MAX.} = 40 \text{ FT (12.2m)}$

VENTING WITH THREE (3) 90° ELBOWS PROPANE

V (MIN.)	MODEL R-3500TR		MODEL R-4500TR		MODEL R-6500TR	
	H (MAX.)	H + H ₁ (MAX.)	H (MAX.)	H + H ₁ (MAX.)	H (MAX.)	H + H ₁ (MAX.)
90° Elbow on Top	3 FT (914mm)	4 FT (1.22m)	2.5 FT (863mm)	3 FT (914mm)	NOT ALLOWED	N/A
1 FT (305mm)	3 FT (914mm)	6 FT (1.86m)	3 FT (914mm)	6 FT (1.86m)	2 FT (914mm)	4 FT (1.22m)
2 FT (610mm)	4 FT (1.22m)	8 FT (2.48m)	4 FT (1.22m)	8 FT (2.48m)	4 FT (1.22m)	8 FT (2.48m)
3 FT (914mm)	6 FT (1.86m)	12 FT (3.72m)	6 FT (1.86m)	12 FT (3.72m)	6 FT (1.86m)	12 FT (3.72m)
4 FT (1.22m)	8 FT (2.48m)	16 FT (4.8m)	8 FT (2.48m)	16 FT (4.8m)	8 FT (2.48m)	16 FT (4.8m)
5 FT (1.52m)	16 FT (4.8m)	16 FT (4.8m)	16 FT (4.8m)	16 FT (4.8m)	16 FT (4.8m)	16 FT (4.8m)

$V + V_1 + H + H_1 \text{ MAX.} = 40 \text{ FT (12.2m)}$

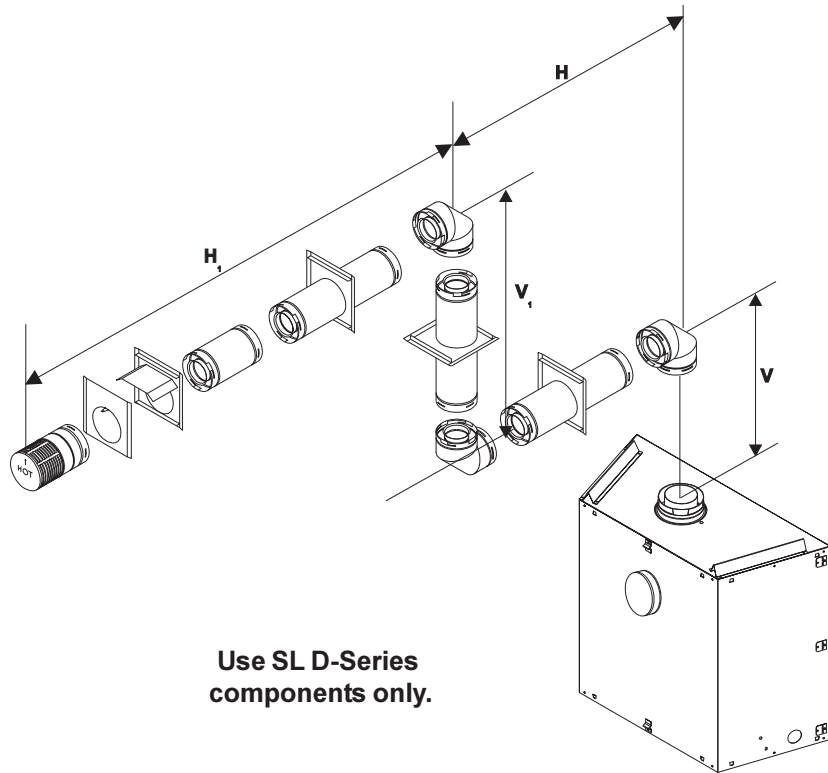

Figure 20. Venting with three 90° elbows - TR MODELS

VENTING WITH THREE (3) 90° ELBOWS

NATURAL GAS

V (MIN.)	MODEL R-3500TRH		MODEL R-4500TRH	
	H (MAX.)	H + H ₁ (MAX.)	H (MAX.)	H + H ₁ (MAX.)
90° Elbow on Top	2 FT (610mm)	4 FT (1.22m)	2 FT (610mm)	4 FT (1.22m)
1 FT (305mm)	3 FT (914mm)	6 FT (1.86m)	3 FT (914mm)	6 FT (1.86m)
2 FT (610mm)	4 FT (1.22m)	8 FT (2.48m)	4 FT (1.22m)	8 FT (2.48m)
3 FT (914mm)	6 FT (1.86m)	12 FT (3.72m)	6 FT (1.86m)	12 FT (3.72m)
4 FT (1.22m)	8 FT (2.48m)	16 FT (4.8m)	8 FT (2.48m)	16 FT (4.8m)
5 FT (1.52m)	16 FT (4.8m)	16 FT (4.8m)	16 FT (4.8m)	16 FT (4.8m)

$V + H + V_1 + H_1 \text{ MAX.} = 40 \text{ FT (12.2m)}$

VENTING WITH THREE (3) 90° ELBOWS

PROPANE

V (MIN.)	MODEL R-3500TRH		MODEL R-4500TRH	
	H (MAX.)	H + H ₁ (MAX.)	H (MAX.)	H + H ₁ (MAX.)
90° Elbow on Top	NOT ALLOWED	NOT ALLOWED	NOT ALLOWED	NOT ALLOWED
1 FT (305mm)	2 FT (610mm)	4 FT (1.22m)	2 FT (610mm)	4 FT (1.22m)
2 FT (610mm)	4 FT (1.22m)	8 FT (2.48m)	4 FT (1.22m)	8 FT (2.48m)
3 FT (914mm)	6 FT (1.86m)	12 FT (3.72m)	6 FT (1.86m)	12 FT (3.72m)
4 FT (1.22m)	8 FT (2.48m)	16 FT (4.8m)	8 FT (2.48m)	16 FT (4.8m)
5 FT (1.52m)	16 FT (4.8m)	16 FT (4.8m)	16 FT (4.8m)	16 FT (4.8m)

$V + H + V_1 + H_1 \text{ MAX.} = 40 \text{ FT (12.2m)}$

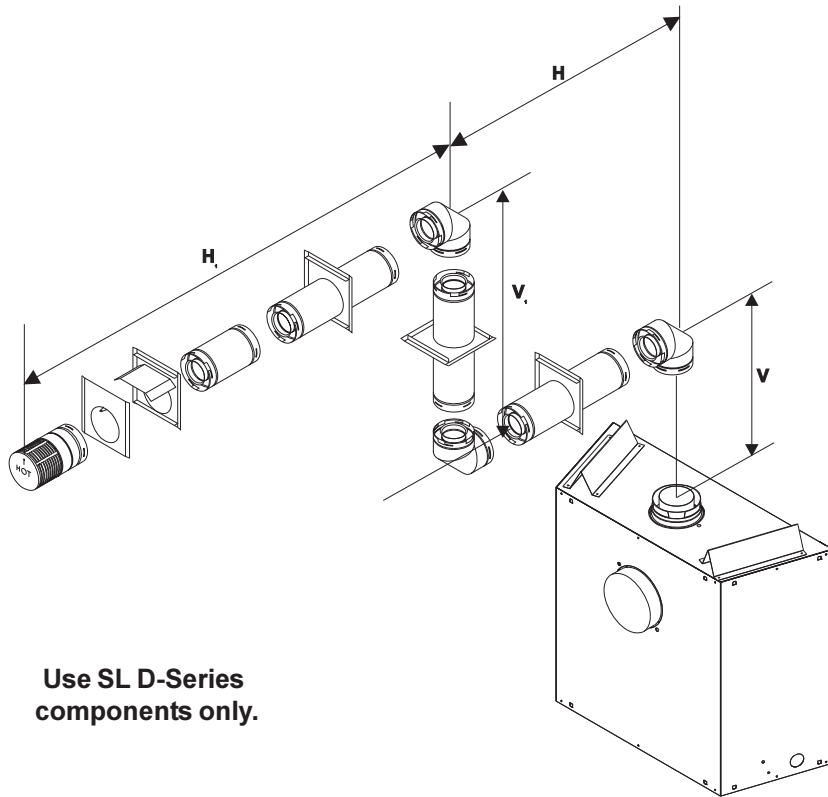

Use SL D-Series components only.

Figure 21. Venting with three 90° elbows - TRH MODELS

VENTING WITH THREE (3) 90° ELBOWS NATURAL GAS

V (MIN.)	MODEL R-3500TR H + H₁ (MAX.)	MODEL R-4500TR H + H₁ (MAX.)	MODEL R-6500TR H + H₁ (MAX.)
90° Elbow on Top	3 FT (914mm)	2.5 FT (863mm)	2 FT (610mm)
1 FT (305mm)	3 FT (914mm)	3 FT (914mm)	3 FT (914mm)
2 FT (610mm)	4 FT (1.22m)	4 FT (1.22m)	4 FT (1.22m)
3 FT (914mm)	6 FT (1.86m)	6 FT (1.86m)	6 FT (1.86m)
4 FT (1.22m)	8 FT (2.48m)	8 FT (2.48m)	8 FT (2.48m)
5 FT (1.52m)	16 FT (4.8m)	16 FT (4.8m)	16 FT (4.8m)
H + H₁ MAX. = 16 FT (4.8m)		V + V₁ + H + H₁ MAX. = 40 FT (12.2m)	

VENTING WITH THREE (3) 90° ELBOWS PROPANE

V (MIN.)	MODEL R-3500TR H + H₁ (MAX.)	MODEL R-4500TR H + H₁ (MAX.)	MODEL R-6500TR H + H₁ (MAX.)
90° Elbow on Top	3 FT (914mm)	2.5 FT (863mm)	NOT ALLOWED
1 FT (305mm)	3 FT (914mm)	3 FT (914mm)	2 FT (610mm)
2 FT (610mm)	4 FT (1.22m)	4 FT (1.22m)	4 FT (1.22m)
3 FT (914mm)	6 FT (1.86m)	6 FT (1.86m)	6 FT (1.86m)
4 FT (1.22m)	8 FT (2.48m)	8 FT (2.48m)	8 FT (2.48m)
5 FT (1.52m)	16 FT (4.8m)	16 FT (4.8m)	16 FT (4.8m)
H + H₁ MAX. = 16 FT (4.8m)		V + V₁ + H + H₁ MAX. = 40 FT (12.2m)	

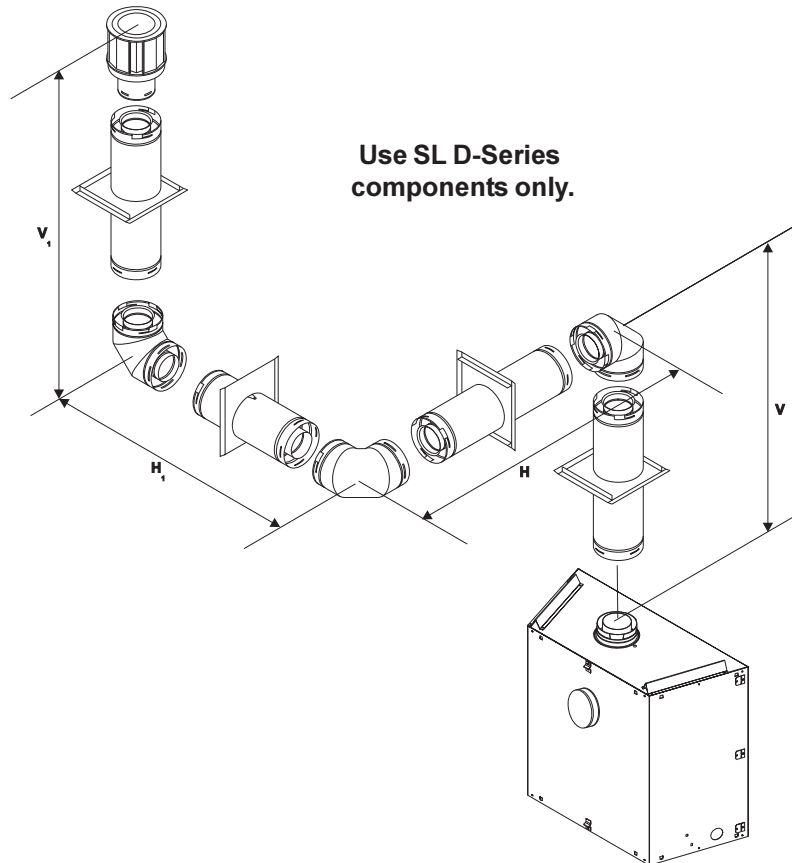

Figure 22. Venting with three 90° elbows - TR MODELS

VENTING WITH THREE (3) 90° ELBOWS

NATURAL GAS

V (MIN.)	MODEL R-3500TRH H + H ₁ (MAX.)	MODEL R-4500TRH H + H ₁ (MAX.)
90° Elbow on Top	2 FT (610mm)	2 FT (610mm)
1 FT (305mm)	3 FT (914mm)	3 FT (914mm)
2 FT (610mm)	4 FT (1.22m)	4 FT (1.22m)
3 FT (914mm)	6 FT (1.86m)	6 FT (1.86m)
4 FT (1.22m)	8 FT (2.48m)	8 FT (2.48m)
5 FT (1.52m)	16 FT (4.8m)	16 FT (4.8m)

H + H₁ MAX. = 16 FT (4.8m) V + V₁ + H + H₁ MAX. = 40 FT (12.2m)

VENTING WITH THREE (3) 90° ELBOWS

PROPANE

V (MIN.)	MODEL R-3500TRH H + H ₁ (MAX.)	MODEL R-4500TRH H + H ₁ (MAX.)
90° Elbow on Top	NOT ALLOWED	NOT ALLOWED
1 FT (305mm)	2 FT (610mm)	2 FT (610mm)
2 FT (610mm)	4 FT (1.22m)	4 FT (1.22m)
3 FT (914mm)	6 FT (1.86m)	6 FT (1.86m)
4 FT (1.22m)	8 FT (2.48m)	8 FT (2.48m)
5 FT (1.52m)	16 FT (4.8m)	16 FT (4.8m)

H + H₁ MAX. = 16 FT (4.8m) V + V₁ + H + H₁ MAX. = 40 FT (12.2m)

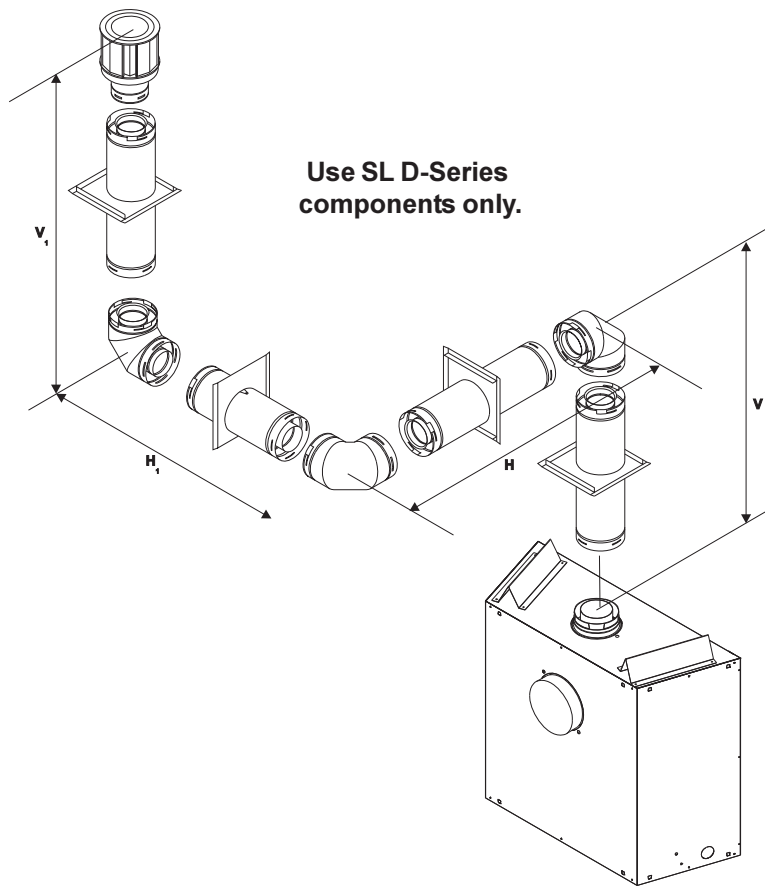

Figure 23. Venting with three 90° elbows - TRH MODELS

B. Installing Vent Components

After determining which set of starting collars will be used (top or rear), follow venting instructions accordingly.

Venting Out the Rear Vent

Remove the installed rear seal cap from the rear starting collars by cutting the strap at each end. (See Figure 24)
Remove the insulation inside the 5" collar. (See Figure 24).
Follow the vent configuration tables accordingly.

Remove the 5" diameter disk in the center of the **REAR** heat shield by twisting the disk and breaking it out. This can be done from inside the firebox or by reaching through the vent.

! WARNING: THE TOP HEAT SHIELD (INSIDE THE FIREBOX) MUST REMAIN ATTACHED IF THE VENT SYSTEM IS ATTACHED TO THE REAR STARTING COLLARS. SEE FIGURE 24.

In models R-3500TRH and R-4500TRH, the disk may be difficult to twist and break. Remove the exhaust shield and rear heat shield. Replace the exhaust shield.

Venting Out the Top Vent

Remove the top vent collar seal cap by cutting the strap at each end. (See Figure 24). Remove the insulation inside **BOTH** collars. (See Figure 24). Next remove the glass door.

Remove the 4" diameter disk in the center of the **TOP** heat shield by twisting the disk and breaking it out. This can be done from inside the firebox or by reaching through the vent.

You have to take the glass off again for positioning the logs when the unit is finally installed in place and finished around it. Re-install the glass door. Attach vent system to the top starting collars.

! WARNING: THE REAR VENT COLLAR SEAL CAP MUST REMAIN ATTACHED TO THE REAR VENT COLLARS IF THE VENT SYSTEM IS ATTACHED TO THE TOP STARTING COLLARS. SEE FIGURE 24.

! WARNING: FAILURE TO REMOVE INSULATION IN THE SET OF COLLARS YOU ARE USING COULD CAUSE A FIRE.

! WARNING: YOU MUST LEAVE THE INSULATION IN PLACE IN THE SET OF COLLARS YOU ARE NOT USING.

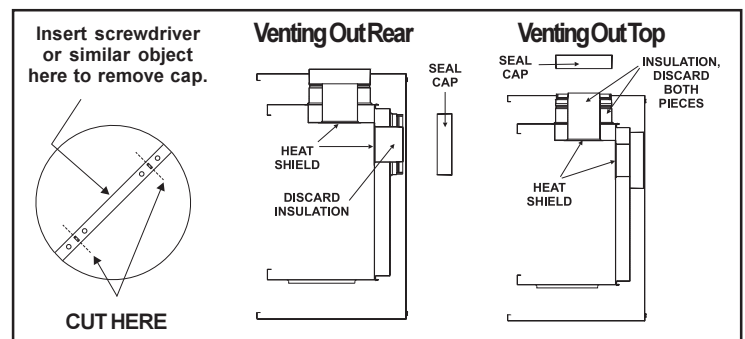

Figure 24

1. Attach the First Vent Component to the Starting Collars

To attach the first vent component to the starting collars of the fireplace:

- Apply a 3/8 inch (9.5 mm) bead of stove cement around the fireplace inner vent starting collar.
- Lock the vent components into place by sliding the concentric pipe sections with four (4) equally spaced interior beads into the fireplace collar or previously installed component end with four (4) equally spaced indented sections.
- When the internal beads of each outer pipe line up, rotate the pipe section clockwise about one-quarter (1/4) turn. The vent pipe is now locked together.

1. Apply the stove cement.
2. Line up the internal beads and rotate the pipe sections clockwise until locked.
3. Lock the vent components into place.

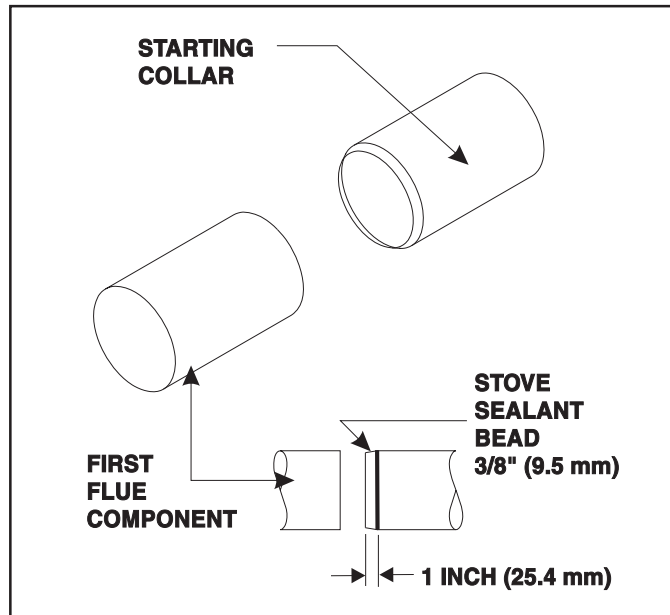

Figure 25. Attaching the First Vent Component to the Starting Collars



WARNING

A 3/8 INCH (9.5 MM) BEAD OF STOVE CEMENT MUST BE PLACED AROUND THE FIREPLACE INNER VENT STARTING COLLAR BEFORE ATTACHING THE FIRST VENT COMPONENT. FAILURE TO SEAL THIS JOINT MAY CAUSE THE FIREPLACE TO OPERATE IMPROPERLY. SEE THE DIAGRAM .

If the installation is for a termination cap attached directly to the fireplace, skip to the sections, **Install Firestops** and **Vent Termination**.

2. Continue Adding Vent Components

To continue adding vent components in accordance with the pre-planned vent system configuration:

- Ensure that each succeeding vent component is securely fitted and locked into the preceding component in the vent system.

90° elbows may be installed and rotated to any point around the preceding component's vertical axis. If an elbow does not end up in a locked position with the preceding component, attach with a minimum of two (2) sheet metal screws.

Continue adding vent components, locking each succeeding component into place.

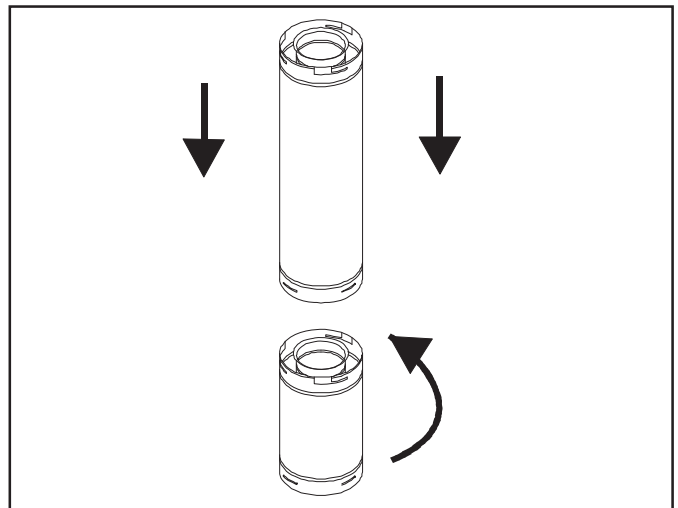

Figure 26. Adding Venting Components

3. Install Support Brackets

For Horizontal Runs - The vent system must be supported every five (5) feet of horizontal run by a horizontal pipe support.

To install support brackets for horizontal runs:

- Place the pipe supports around the vent pipe.
- Nail the pipe supports to the framing members.

For Vertical Runs - The vent system must be supported every eight (8) feet (2.4 m) above the fireplace flue outlet by wall brackets.

To install support brackets for vertical runs:

- Attach wall brackets to the vent pipe and secure the wall bracket to the framing members with nails or screws.

Use wall brackets to support vertical runs every 8 feet (2.4 m) above the fireplace flue outlet.

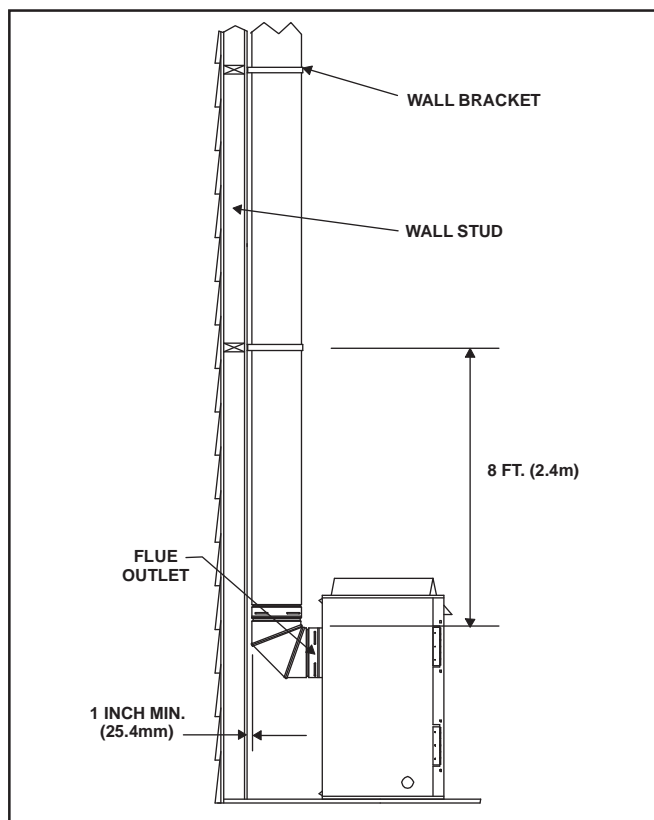

Figure 27. Installing Support Brackets

4. Install Firestops

For Horizontal Runs - Firestops are **REQUIRED** on both sides of a combustible wall through which the vent passes.

NOTE

Model DVK-01TRD or SLK-01TRD do not need an exterior firestop on an exterior combustible wall.

To install firestops for horizontal runs that pass through either interior or exterior walls:

- Cut a 12-inch by 12-inch (305 mm X 305 mm) hole through the wall for D-series or a 10-inch by 10-inch (254 mm X 254 mm) hole for SL-D-series pipe. The center of the hole is one (1) inch (25.4 mm) above the center of the horizontal vent pipe.

1. Cut the hole through the wall.

- Position the firestops on both sides of the hole previously cut and secure the firestops with nails or screws.
- The heat shields of the firestops **MUST BE** placed towards the top of the hole.
- Continue the vent run through the firestops.

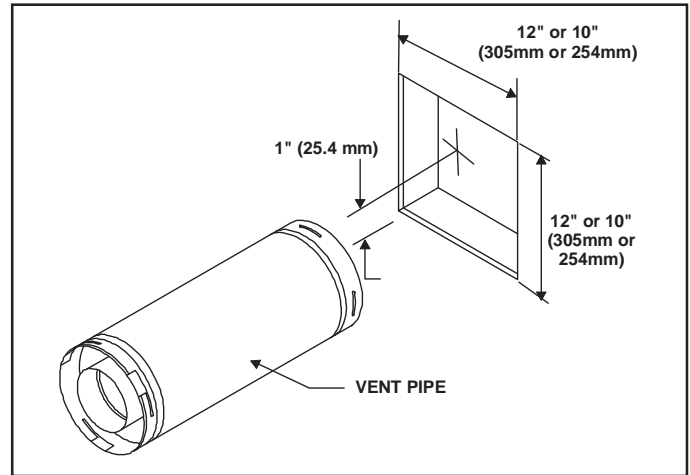

Figure 28. Hole and Vent Pipe

2. Position the firestops.
3. Place the heat shield to the top.
4. Continue the vent run.

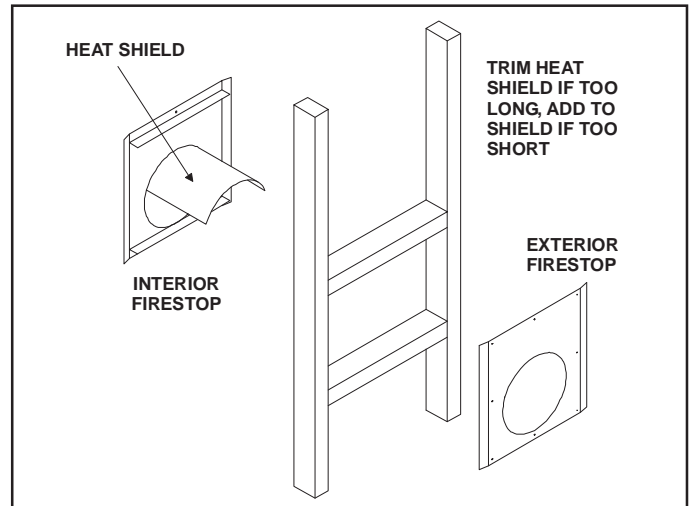

Figure 29. Heat Shield, Interior and Exterior Firestops

For Vertical Runs - One ceiling firestop is **REQUIRED** at the hole in each ceiling through which the vent passes.

To install firestops for vertical runs that pass through ceilings:

- Position a plumb bob directly over the center of the vertical vent component.
- Mark the ceiling to establish the centerpoint of the vent.

- Drill a hole or drive a nail through this centerpoint.
- Check the floor above for any obstructions, such as wiring or plumbing runs.
- Reposition the fireplace and vent system, if necessary, to accommodate the ceiling joists and/or obstructions.
- Cut an 11-inch X 11-inch (280 mm X 280 mm) for D-series or 10-inch X 10-inch (254 mm X 254 mm) for SLD-series pipe hole through the ceiling, using the centerpoint previously marked.
- Frame the hole with framing lumber the same size as the ceiling joists.

1. Cut the ceiling hole.
2. Add the new framing members.

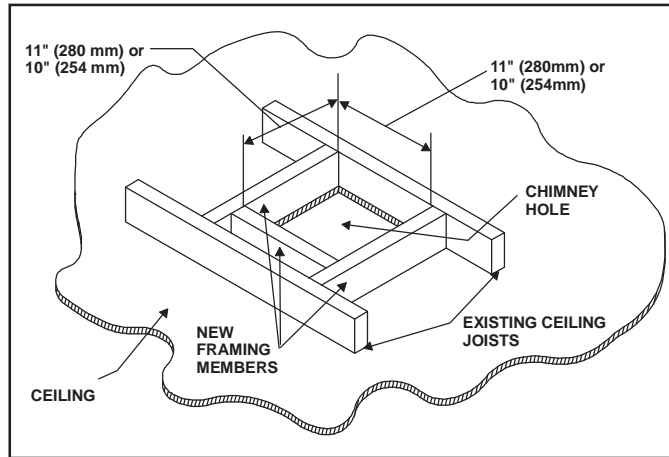

Figure 30. Hole and New Framing Members

If the area above the ceiling is **NOT** an attic, position and secure the ceiling firestop on the ceiling side of the previously cut and framed hole.

This shows a ceiling installation.

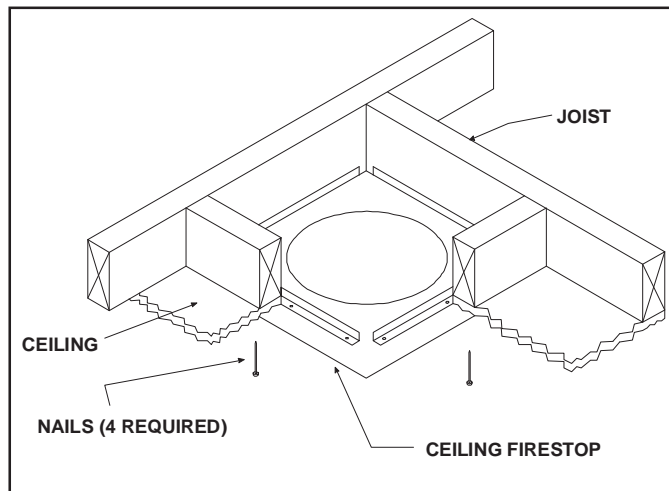

Figure 31. Ceiling Firestop (Ceiling Side)

If the area above the ceiling **IS** an attic, position and secure the firestop on top of the previously framed hole.

This shows an attic installation.

1. Keep insulation away from the vent pipe at least 1 inch (25 mm).

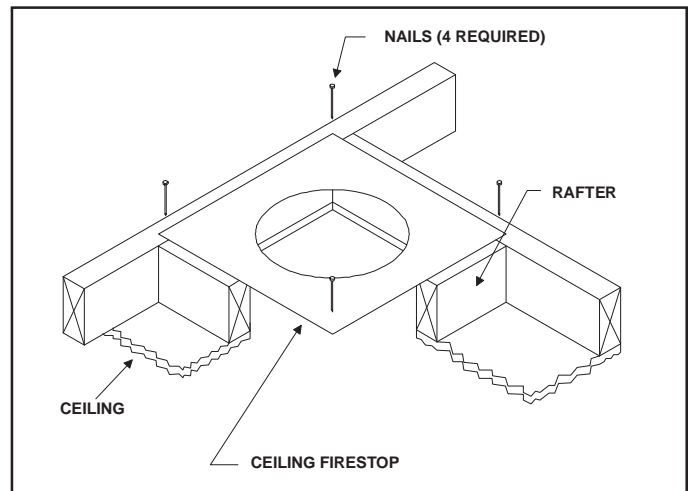

Figure 32. Attic Firestop

C. Vent Termination

For Horizontal Terminations - To attach and secure the termination to the last section of horizontal vent:

- Rotate and interlock the ends as described at the beginning of the Installing Vent Components section.
- The termination kit should pass through the wall firestops from the exterior of the building.
- Adjust the termination cap to its final exterior position on the building.



WARNING
THE TERMINATION CAP MUST BE POSITIONED SO THAT THE ARROW IS POINTING UP.

For roundcap termination kits:

- Use the exterior pipelock hole provided on the round flange of the wall firestop to secure the vent pipe in place.

For trapezoidal cap termination kits:

- Using screws, secure the cap to the exterior wall through the flanges built into the cap.

For round cap termination:

1. Secure the pipe, using the exterior pipelock hole on the round flange of the wall firestop.

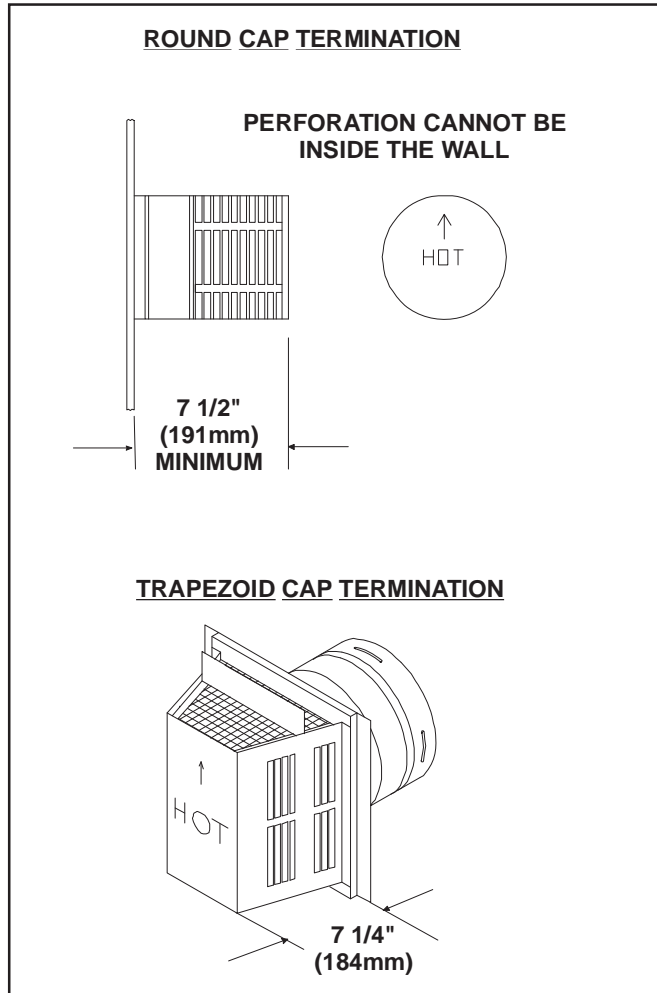

For trapezoidal termination:

1. Screw the cap to the exterior wall through the flanges in the cap.
2. Seal the joint between the pipe and the exterior firestop.

Figure 33. Round and Trapezoid Termination Caps



WARNING

THE BOTTOM OF THE VENT TERMINATION CAP MUST BE A MINIMUM OF 12 INCHES (305 MM) ABOVE GROUND LEVEL (GRADE). THE TOP OF THE CAP MUST BE A MINIMUM OF 18 INCHES (457 MM) BELOW COMBUSTIBLE MATERIAL, SUCH AS A DECK, AND THE SIDE OF THE CAP MUST BE A MINIMUM OF 6 INCHES (152 MM) AWAY FROM A PARALLEL OUTSIDE WALL. VENTING TERMINALS SHALL NOT BE RECESSED INTO A WALL OR SIDING. SEE THE FOLLOWING DIAGRAM FOR VENT TERMINATION CLEARANCES.

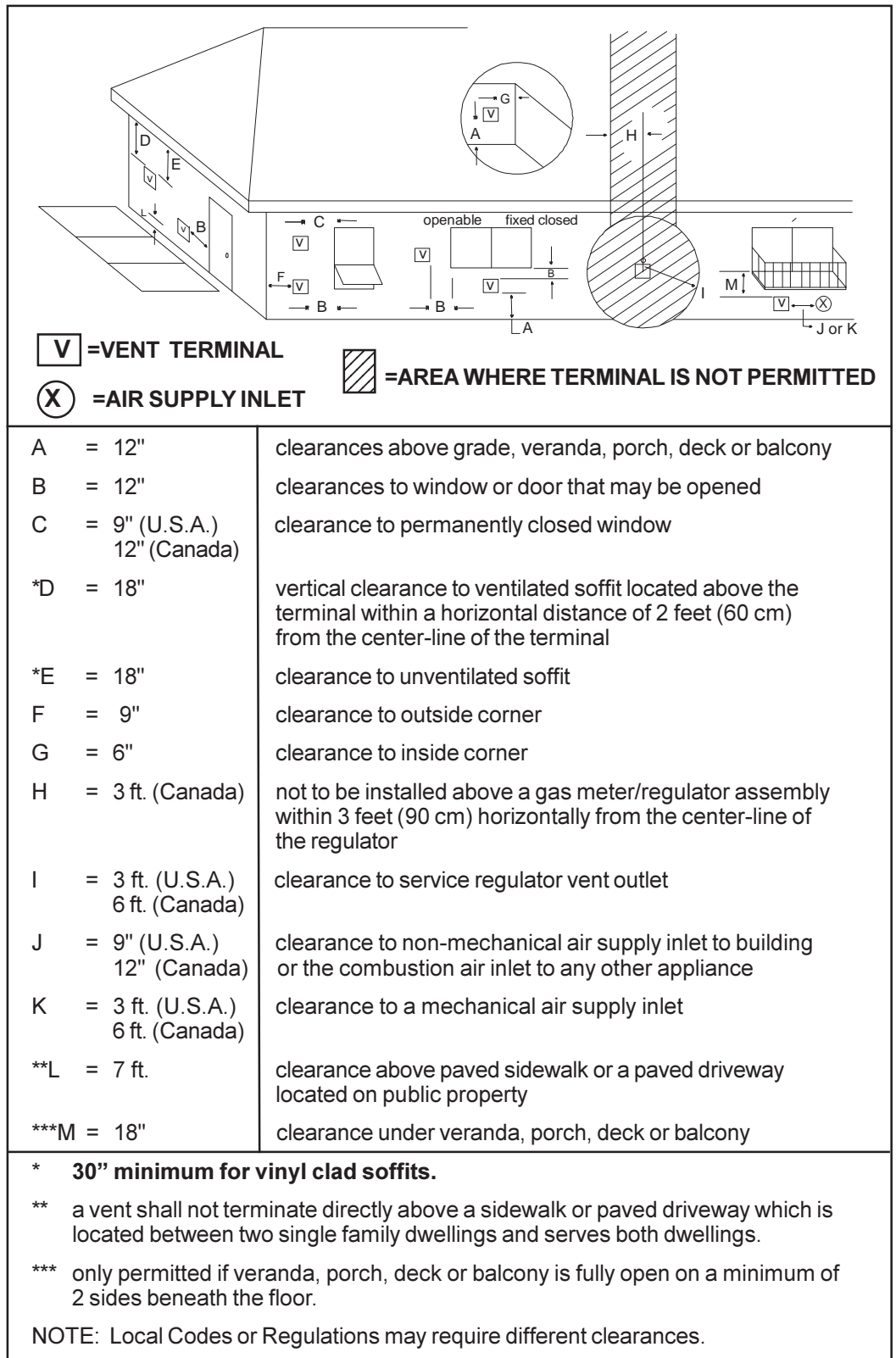

Figure 34. Vent Termination Minimum Clearances

CAUTION

IF INSTALLING UNITS R-3500TRH AND R-4500TRH OR R-6500TR, AND EXTERIOR WALLS ARE FINISHED WITH VINYL SIDING, IT IS NECESSARY TO INSTALL THE VINYL PROTECTOR KIT TO THE TOP OF THE EXTERIOR FIRESTOP (FOR ALL ROUND TERMINATION CAPS). IT IS STRONGLY RECOMMENDED WHENEVER POSSIBLE TO USE THE VINYL PROTECTOR KIT.

For Vertical Terminations - To locate the vent and install the vent sections:

- Locate and mark the vent centerpoint on the underside of the roof, and drive a nail through the centerpoint.
- Make the outline of the roof hole around the centerpoint nail.
- The size of the roof hole framing dimensions depend on the pitch of the roof. There **MUST BE** a 1-inch (25.4 mm) clearance from the vertical vent pipe to combustible materials.
- Mark the roof hole accordingly.
- Cover the opening of the installed vent pipes.
- Cut and frame the roof hole.
- Use framing lumber the same size as the roof rafters and install the frame securely. Flashing anchored to the frame must withstand heavy winds.
- Continue to install concentric vent sections up through the roof hole and up past the roof line until you reach the appropriate distance above the roof.



WARNING
MAJOR U.S. BUILDING CODES SPECIFY MINIMUM CHIMNEY AND/OR VENT HEIGHT ABOVE THE ROOF TOP. THESE MINIMUM HEIGHTS ARE NECESSARY IN THE INTEREST OF SAFETY. SEE THE FOLLOWING DIAGRAM FOR MINIMUM HEIGHTS, PROVIDED THE TERMINATION CAP IS AT LEAST TWO (2) FEET FROM A VERTICAL WALL AND 2-FEET BELOW A HORIZONTAL OVERHANG.

NOTE

This also pertains to vertical vent systems installed on the outside of the building.

To seal the roof hole, and to divert rain and snow from the vent system:

- Attach a flashing to the roof using nails, and use a non-hardening mastic around the edges of the flashing base where it meets the roof.
- Attach a storm collar over the flashing joint to form a water-tight seal. Place non-hardening mastic around the joint, between the storm collar and the vertical pipe.
- Slide the termination cap over the end of the vent pipe and rotate the pipe clockwise 1/4 turn.

1. Attach the flashing and apply sealant around the edges of the flashing base.
2. Attach the storm collar over the flashing joint and apply sealant between the storm collar and vertical pipe.

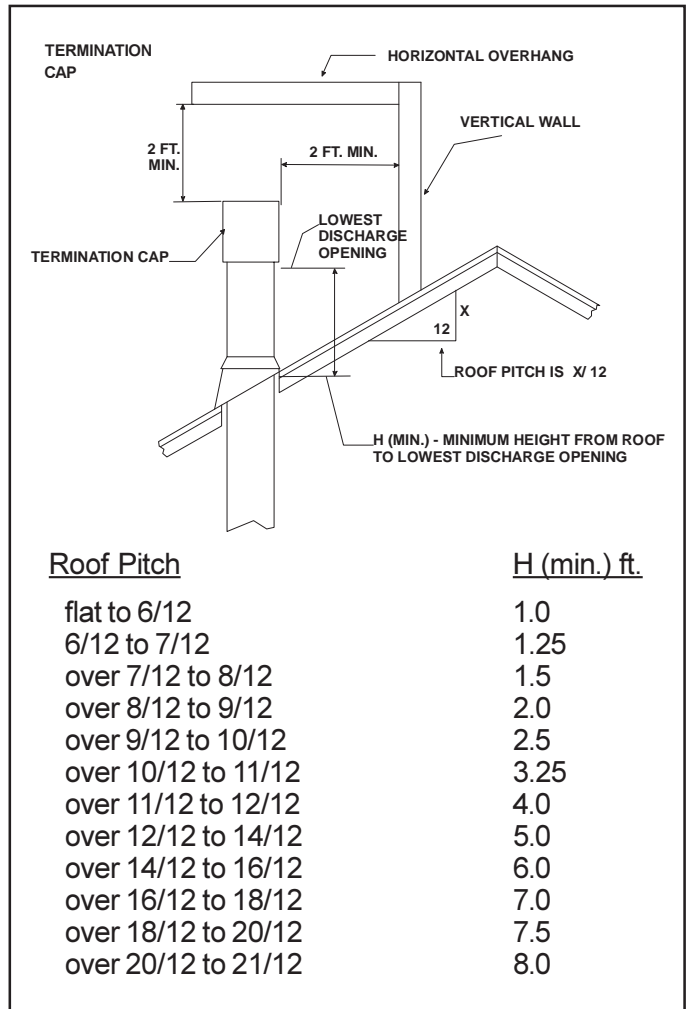

Figure 35. Minimum Height from Roof to Lowest Discharge Opening

Step 4 Positioning, Leveling, and Securing the Fireplace

1. Place the fireplace into position.
2. Level the fireplace from side to side and from front to back.
3. Shim the fireplace with non-combustible material, such as sheet metal, as necessary.
4. Secure the fireplace to the framing by nailing or screwing

The diagram below shows how to properly position, level, and secure the fireplace.

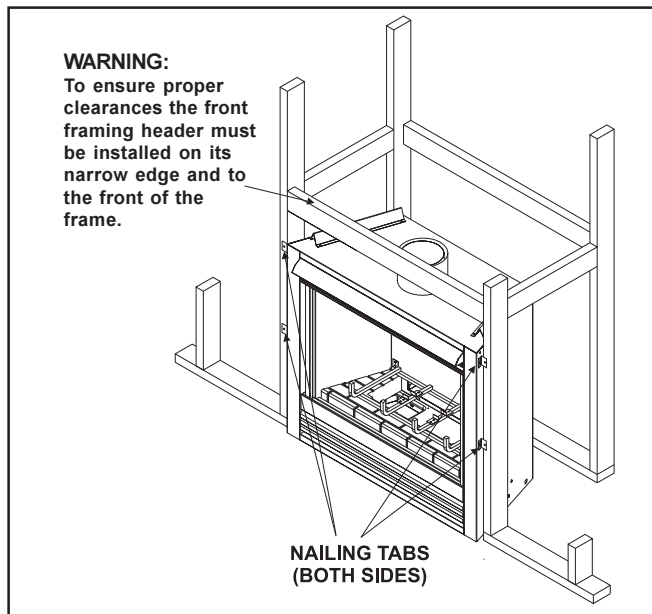

Figure 36. Proper Positioning, Leveling, and Securing of a Fireplace

Step 5 The Gas Control Systems



WARNING: THIS UNIT IS NOT FOR USE WITH SOLID FUEL.

Two types of gas control systems are used with these models: *Standing Pilot Ignition* and *Direct Spark Ignition (DSI)*. Model R-3500TRH and R-4500TRH have Standing Pilot Ignition only.

Standing Pilot Ignition System

This system includes millivolt control valve, standing pilot, thermopile/thermocouple flame sensor, and piezo ignitor.



WARNING
110-120 VAC MUST NEVER BE CONNECTED TO A CONTROL VALVE IN A MILLIVOLT SYSTEM.

Direct Spark Ignition (DSI) System

This system includes a 120VAC control valve, electronic module and spark ignitor/flame sensor.



WARNING: CONTINUOUS 110-120 VAC SERVICE MUST BE WIRED DIRECTLY TO THE FIREPLACE JUNCTION BOX IN A DSI SYSTEM.



WARNING
DIRECT VENT PROPANE MODELS WITH DSI CONTROL SYSTEMS CANNOT BE USED IN CANADA.

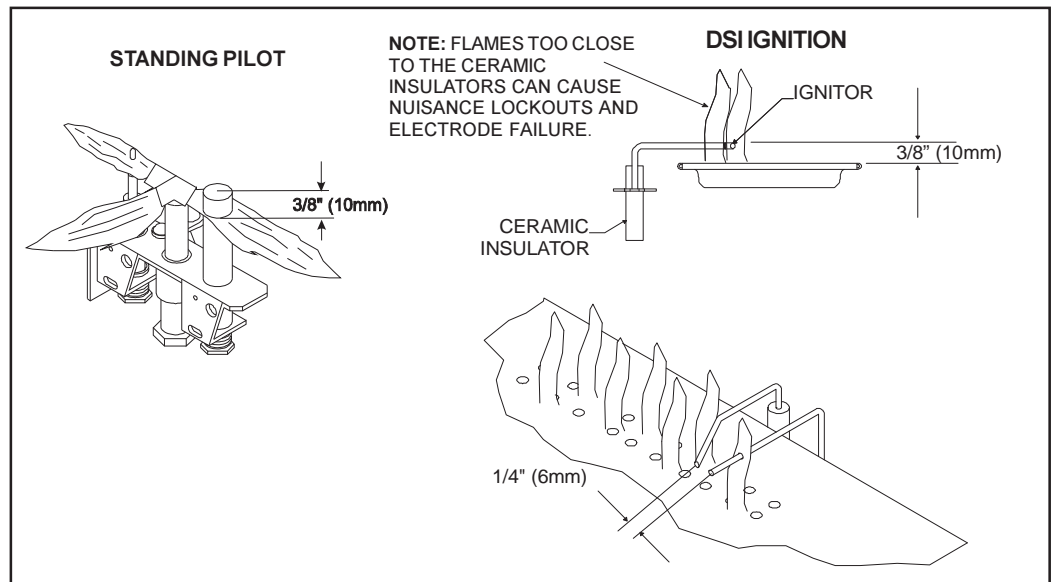

Figure 37. Gas Controls Systems

Step 6 The Gas Supply Line

NOTE: Have the gas supply line installed by a qualified service technician in accordance with all building codes.

NOTE: Before the first firing of the fireplace, the gas supply line should be purged of any trapped air.

NOTE: Consult local building codes to properly size the gas supply line leading to the 1/2 inch (13 mm) hook-up at the unit.

This gas fireplace is designed to accept a 1/2 inch (13 mm) gas supply line.

To install the gas supply line:

- A listed manual shut-off valve and a listed flexible gas connector are connected to the 3/8 inch (10 mm) inlet of the control valve. Some gas control valves have this tapping on the face of the valve.
- The gas line may be run from either side of the fireplace provided the hole in the outer wrap does not exceed 2 inches in diameter and it does not penetrate the airtight firebox.
- The gap between the supply piping and gas access hole can be plugged with non-combustible insulation to prevent cold air infiltration.
- Locate the gas line access hole in the outer casing of the fireplace.
- Open the fireplace lower grille, insert the gas supply line through the gas line hole, and connect it to the shut-off valve.
- When attaching the pipe, support the control so that the lines are not bent or torn.
- After the gas line installation is complete, use a soap solution to carefully check all gas connections for leaks.

⚠ WARNING: DO NOT USE AN OPEN FLAME TO CHECK FOR GAS LEAKS.

- At the gas line access hole, use insulation to repack the space around the gas pipe.
- Insert insulation from the outside of the fireplace and pack the insulation tightly to totally seal between the pipe and the outer casing.

The gas line should be installed by a qualified service technician.

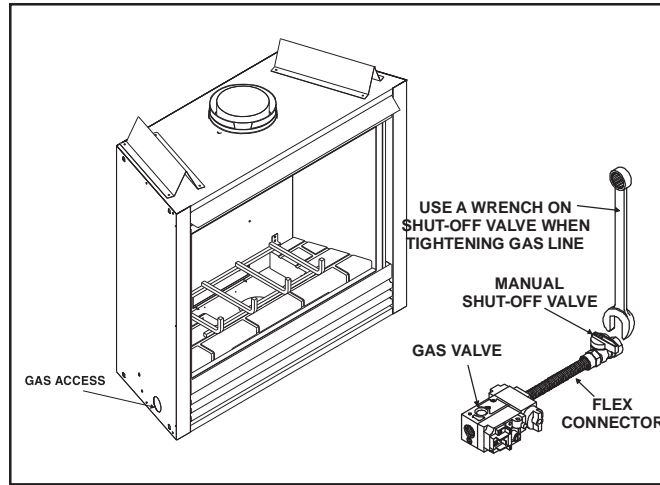

Figure 38. Gas Supply Line

Step 7 Gas Pressure Requirements

Pressure requirements for Royal gas fireplaces are shown in the table below.

Pressure	Natural Gas	Propane
Minimum Inlet Pressure	5.0 inches w.c.	11.0 inches w.c.
Maximum Inlet Gas Pressure	14.0 inches w.c.	14.0 inches w.c.
Manifold Pressure	3.5 inches w.c.	10.0 inches w.c.

A one-eighth (1/8) inch (3 mm) N.P.T. plugged tapping is provided on the inlet and outlet side of the gas control for a test gauge connection to measure the manifold pressure.

Some gas control valves have inlet supply and manifold pressure tappings on the face of the valve.

The fireplace and its individual shut-off valve must be disconnected from the gas supply piping system during any pressure testing of the system at test pressures in excess of one-half (1/2) psig (3.5 kPa).

The fireplace must be isolated from the gas supply piping system by closing its individual shut-off valve during any pressure testing of the gas supply piping system at test pressures equal to or less than one-half (1/2) psig (3.5 kPa).

Step 8 Wiring the Fireplace

CAUTION

NOTE: Electrical wiring must be installed by a licensed electrician.

DISCONNECT REMOTE CONTROLS IF YOU ARE ABSENT FOR EXTENDED TIME PERIODS. THIS WILL PREVENT ACCIDENTAL FIREPLACE OPERATION.

For Standing Pilot Ignition Wiring

Appliance Requirements

- This appliance **DOES NOT** require 110-120 VAC to operate.



WARNING

DO NOT CONNECT 110-120 VAC TO THE GAS CONTROL VALVE OR REMOTE WALL SWITCH OR THE APPLIANCE WILL MALFUNCTION AND THE VALVE WILL BE DESTROYED.

Optional Accessories

Optional fan and remote control kits require that 110-120 VAC be wired to the factory installed junction box before the fireplace is permanently installed.

Remote Wall Switch

Position the remote wall switch in the desired position on a wall. Run a maximum of 25 feet (7.8 m) or less length of 18 A.W.G. minimum wire and connect it to the fireplace ON/OFF switch pigtails.

CAUTION

LABEL ALL WIRES PRIOR TO DISCONNECTION WHEN SERVICING CONTROLS. WIRING ERRORS CAN CAUSE IMPROPER AND DANGEROUS OPERATION. VERIFY PROPER OPERATION AFTER SERVICING.

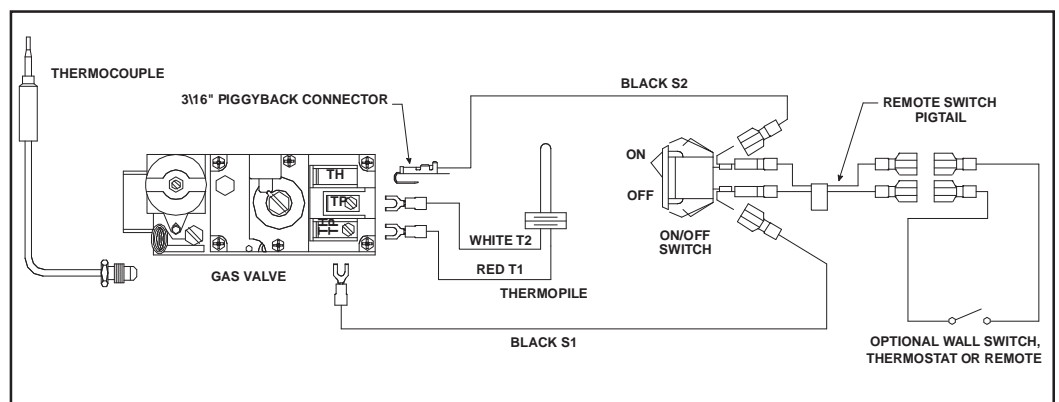

Figure 39. Standing Pilot Ignition Wiring Diagram

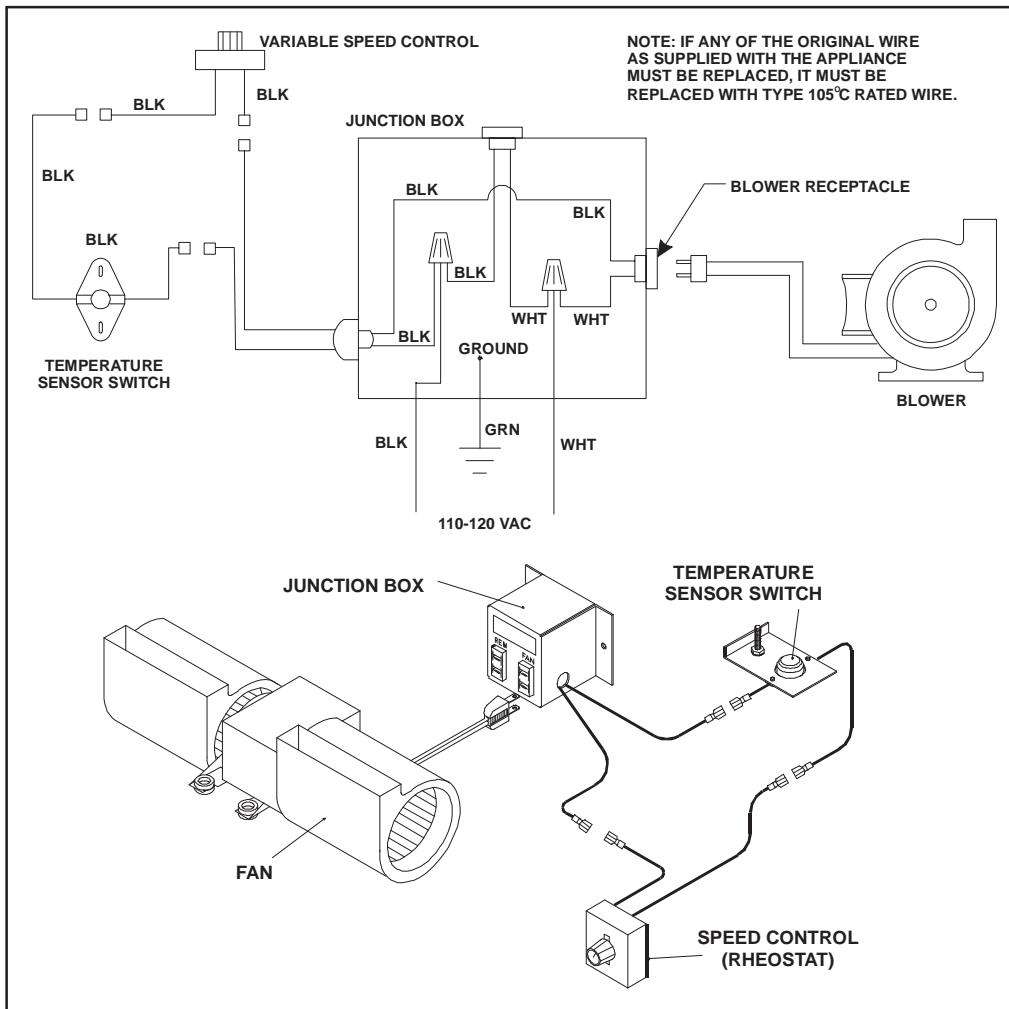

Figure 40. Fan Wiring Diagram

For Direct Spark Ignition (DSI) Wiring

Appliance Requirements

This appliance requires that 110-120 VAC be wired to the junction box included in the manual bag assembly. Maintain correct polarity when wiring the junction box.

The junction box is installed by sliding one tab of the box through the slot on the lower right side of the outer wrap and driving a screw through the other tab into the pilot hole on the outer wrap.

Optional Accessories

Optional fan and remote control kits require that 110-120 VAC be wired to the fireplace junction box.

Remote Wall Switch

Position the remote wall switch in the desired position on a wall. Run 16 A.W.G. minimum Romex wire and connect it to the fireplace ON/OFF switch pigtailed.

Electrical wiring must be installed by a licensed electrician.

NOTE

CAUTION

LABEL ALL WIRES PRIOR TO DISCONNECTION WHEN SERVICING CONTROLS. WIRING ERRORS CAN CAUSE IMPROPER AND DANGEROUS OPERATION. VERIFY PROPER OPERATION AFTER SERVICING.

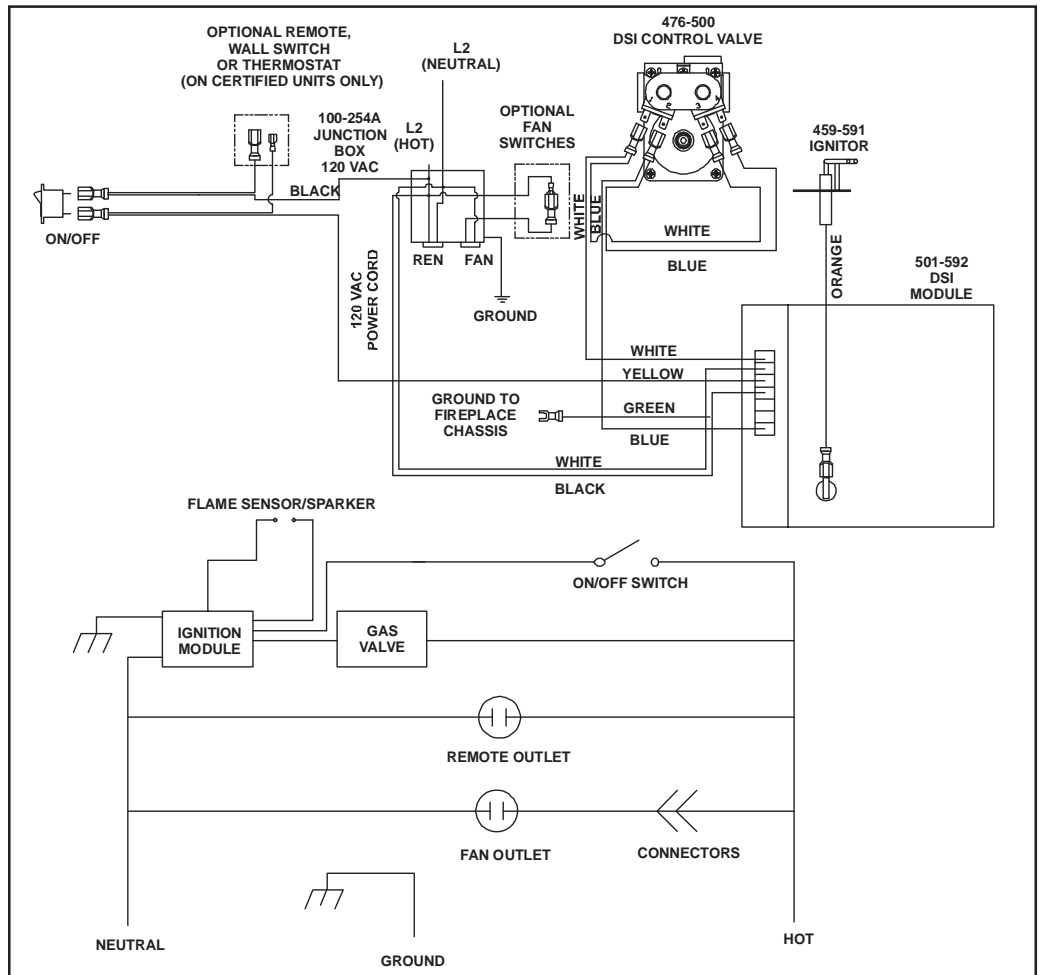

Figure 41. Direct Spark Ignition (DSI) Wiring Diagram

Step 9 Finishing

The following diagram shows the minimum vertical and corresponding maximum horizontal dimensions of fireplace mantels or other combustible projections above the top front edge of the fireplace. See Figures 4 and 5 for other fireplace clearances.

Only non-combustible materials may be used to cover the black fireplace front.

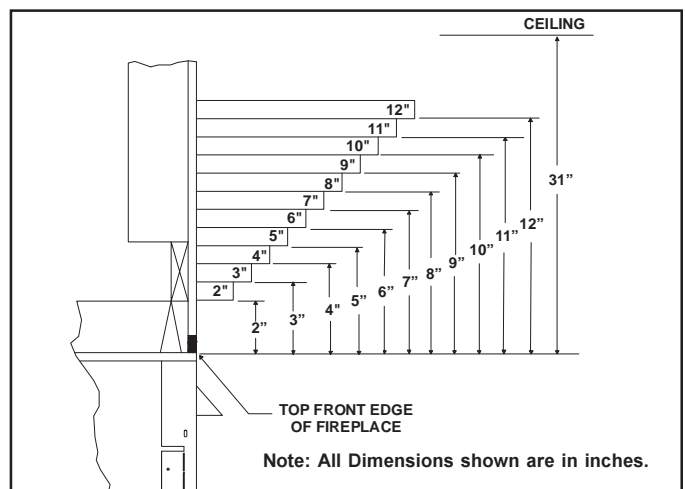

Figure 42. Minimum Vertical and Maximum Horizontal Dimensions of Combustibles above Fireplace



WARNING: WHEN FINISHING THE FIREPLACE, NEVER OBSTRUCT OR MODIFY THE AIR INLET/OUTLET GRILLES IN ANY MANNER.

CAUTION

IF JOINTS BETWEEN THE FINISHED WALLS AND THE FIREPLACE SURROUND (TOP AND SIDES) ARE SEALED, A 300° F. MINIMUM SEALANT MATERIAL MUST BE USED. THESE JOINTS ARE NOT REQUIRED TO BE SEALED. ONLY NON-COMBUSTIBLE MATERIAL (USING 300° F. MINIMUM ADHESIVE, IF NEEDED) CAN BE APPLIED AS FACING TO THE FIREPLACE SURROUND. SEE THE DIAGRAM SHOWN BELOW.

1. Apply only non-combustible facing material to the fireplace surround.

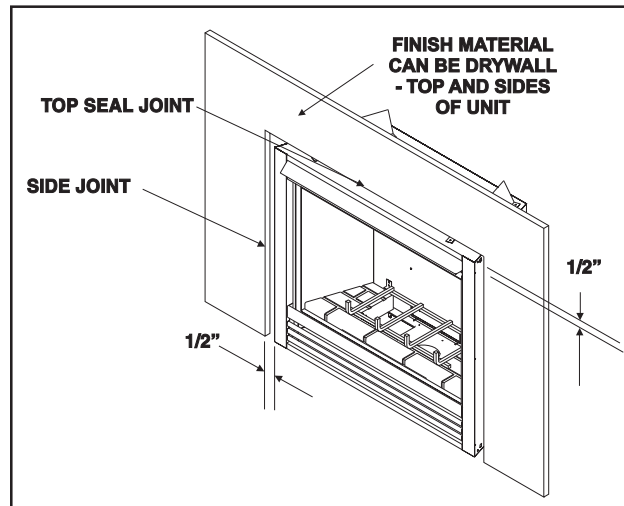

Figure 43. Sealant Material

Hearth Extensions

A hearth extension may be desirable for aesthetic reasons. However, ANSI or CAN/CGA testing standards **do not** require hearth extensions for gas fireplace appliances.

Installing the Trim

Combustible materials may be brought up to the specified clearances on the side and top front edges of the fireplace, but **MUST NEVER** overlap onto the front face. The joints between the finished wall and the fireplace top and sides can only be sealed with a 300° F. (149° C) minimum sealant.



WARNING
WHEN FINISHING THE FIREPLACE,
NEVER OBSTRUCT OR MODIFY THE
AIR INLET/OUTLET GRILLES IN ANY
MANNER.

Install optional marble and brass trim surround kits as desired. Marble, brass, brick, tile, or other non-combustible materials can be used to cover up the gap between the sheet rock and the fireplace.

Do not obstruct or modify the air inlet/outlet grilles. When overlapping on both sides, leave enough space so that the bottom grille can be opened and the trim door removed.

Step 10 Installing Trim, Logs, and Ember Material

Positioning the Logs

If the gas logs have been factory installed they should not need to be positioned.

If the logs have been packaged separately, refer to the installation instructions that accompany the logs.

Save the log instructions with this manual.

If sooting occurs, the logs might need to be repositioned slightly to avoid excessive flame impingement.

Placing the Ember Material

Two separate bags of ember material are shipped with this gas fireplace:

- The bag labeled Golden Ember (GE-93) is flame colorant material.
- The bag labeled Glowing Ember (050-721) is standard glowing ember material.

To place the ember material:

- Remove the top louver by lifting it up and away from the unit.
- Unlatch the latches at the top and bottom of the glass door.
- Remove the glass door from the unit.

1. Lift the top louver up and out of the unit.
2. Unlatch and remove the glass door from the unit.

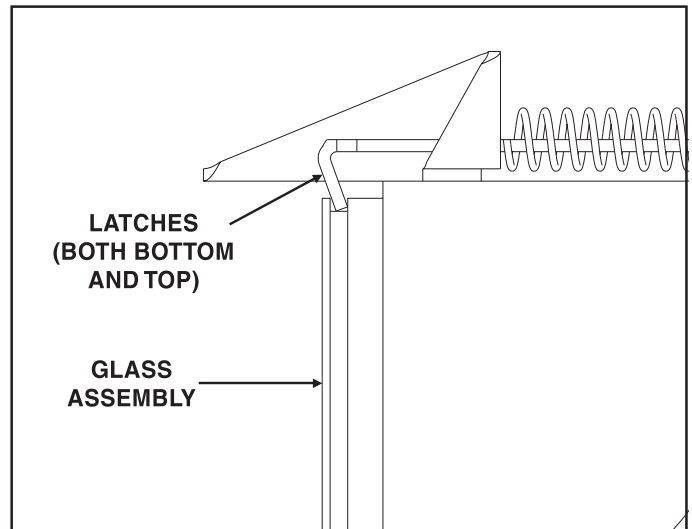

Figure 44. Glass Assembly

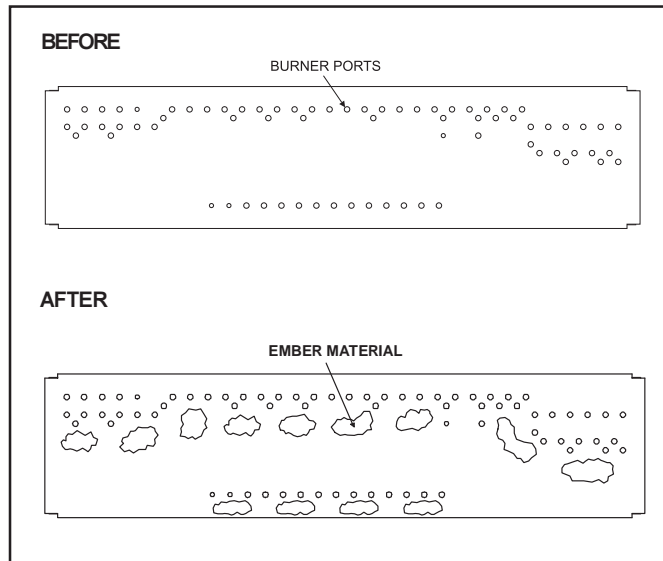

Figure 45. Placement of the Ember Material

- Place a dime size piece of Glowing Embers (050-721) near port holes in burner top (see Figure 45).
- Space ember pieces about a 1/2 inch apart.
- Embers should be set onto burner top, never press embers into burner ports.
- Cover the top of the burner with a single layer of ember material (see Figure 45). Then sprinkle GE-93 on top of the burner.
- Save the remaining ember materials for use during fireplace servicing. The bag of embers provided is sufficient for 3 to 5 applications.
- Reinstall and latch the glass door and top louver on the unit (see Replacement Parts Section of the manual.)

CAUTION

THE GLASS DOOR MUST BE SECURELY LATCHED BEFORE OPERATING THE UNIT.

CAUTION

IT IS STRONGLY RECOMMENDED THAT TRIM DOORS WITH OPTIONAL MESH SCREENS BE INSTALLED ON PROPANE MODELS.

Step 11 Before Lighting the Fireplace

Before lighting the fireplace, be sure to do the following:

Remove all paperwork and documents from underneath the fireplace.

Review safety warnings and cautions

- Read the **Safety and Warning Information** section at the beginning of this *Installers Guide*.

Double-check for gas leaks

- Before lighting the fireplace, double-check the unit for possible gas leaks.

Double-check vent terminations and front grilles for obstructions.

- Before lighting the fireplace, double-check the unit for possible obstructions that could be blocking the vent terminations or the front grilles.

Double-check for faulty components

- Any component that is found to be faulty **MUST BE** replaced with an approved component. Tampering with the fireplace components is **DANGEROUS** and voids all warranties.

A small amount of air will be in the gas supply lines. When first lighting the fireplace, it will take a few minutes for the lines to purge themselves of this air. Once the purging is complete, the fireplace will light and will operate normally.

NOTE: *The fireplace should be run for 8 hours on the initial start-up. This will help to cure the chemicals used in the paint and logs.*

Subsequent lightings of the fireplace will not require this purging of air from the gas supply lines, **unless the gas valve has been turned to the OFF position**, in which case the air would have to be purged.

You've reviewed all safety warnings, you've checked the fireplace for gas leaks, you know the vent system is unobstructed, and you've checked for faulty components. Now you're ready to light the fireplace.



WARNING
PLEASE REFER TO THE USER'S
MANUAL FOR ALL CAUTIONS, SAFETY,
AND WARNING INFORMATION
PERTAINING TO THE LIGHTING AND
OPERATION OF THE FIREPLACE.

Step 12 Lighting the Fireplace

After the Installation

LEAVE THIS INSTALLATION MANUAL
WITH THE APPLIANCE FOR FUTURE
REFERENCE.

4

Maintaining and Servicing Your Fireplace

Fireplace Maintenance

Although the frequency of your fireplace servicing and maintenance will depend on use and the type of installation, you should have a qualified service technician perform an appliance check-up at the beginning of each heating season. See the table below for specific guidelines regarding each fireplace maintenance task.

IMPORTANT

TURN OFF THE GAS BEFORE SERVICING YOUR FIREPLACE.

Type of Fireplace Maintenance	Frequency	By	Fireplace Maintenance Task To Be Completed
Replacing Old Ember Material	Once annually, during the annual check-up	Qualified Service Technician	Brush away loose ember material near the burner. Replace old ember material with new dime-size and -shape pieces of Golden Ember (GE-93) and Glowing Ember (050-721). New ember material should be placed alternately on top of the burner—a layer of Golden Ember, a layer of Glowing Ember, and so on. Save the remaining ember material and repeat this procedure at your next servicing. For more information, see Placing Ember Material in the INSTALLERS GUIDE .
Cleaning Burner & Controls	Once annually	Qualified Service Technician	Brush or vacuum the control compartment, fireplace logs, and burner areas surrounding the logs.
Checking Flame Patterns, Flame Height	Periodically	Qualified Service Technician/ Owner	Make a visual check of your fireplace's flame patterns. Make sure the flames are steady—not lifting or floating. See the picture in Figure 46. The flame sensor (DSI) or thermopile/thermocouple (standing pilot) tips should be covered with flame. See the picture in Figure 47.
Checking Vent System	Before initial use and at least annually thereafter, more frequently if possible	Qualified Service Technician/ Owner	Inspect the external vent cap on a regular basis to ensure that no debris is interfering with the flow of air. Inspect entire venting system for proper function.
Cleaning Glass Door	As necessary	Homeowner	Clean as necessary, particularly after adding new ember (flame colorant) material. Film deposits on the inside of the glass door should be cleaned off using a household glass cleaner. NOTE: DO NOT handle or attempt to clean the door when it is hot and DO NOT use abrasive cleaners.

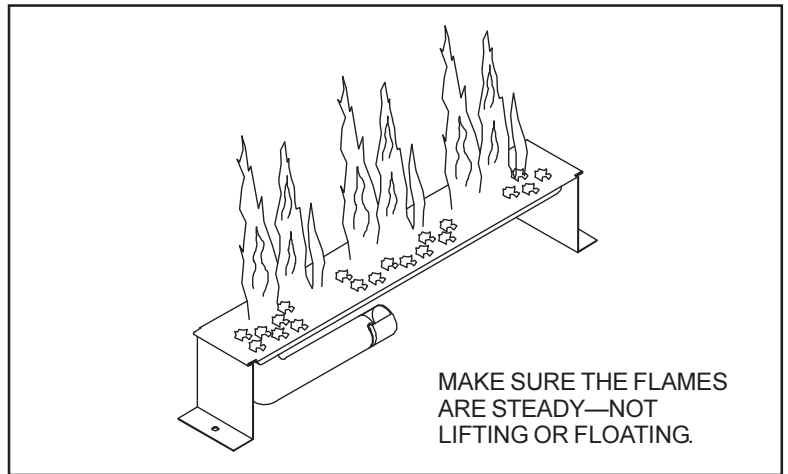

Figure 46. Burner Flame Patterns

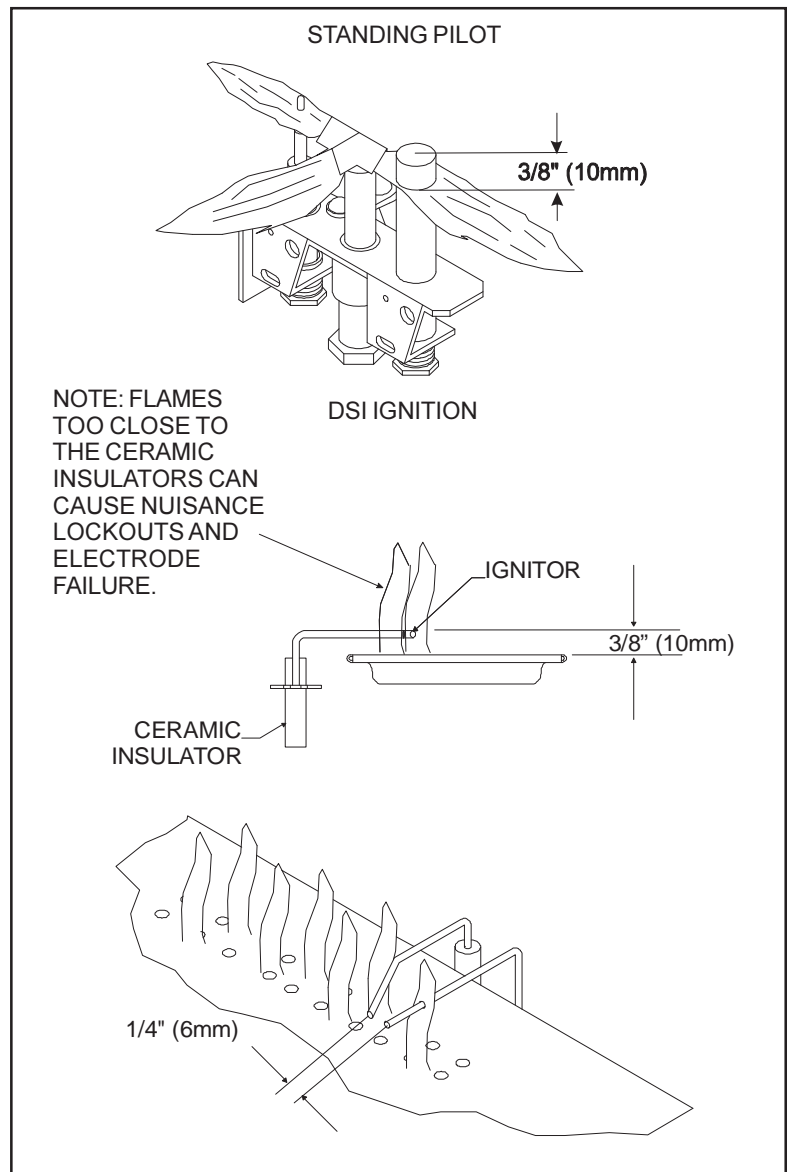

Figure 47. Pilot/Ignitor Flame Patterns