

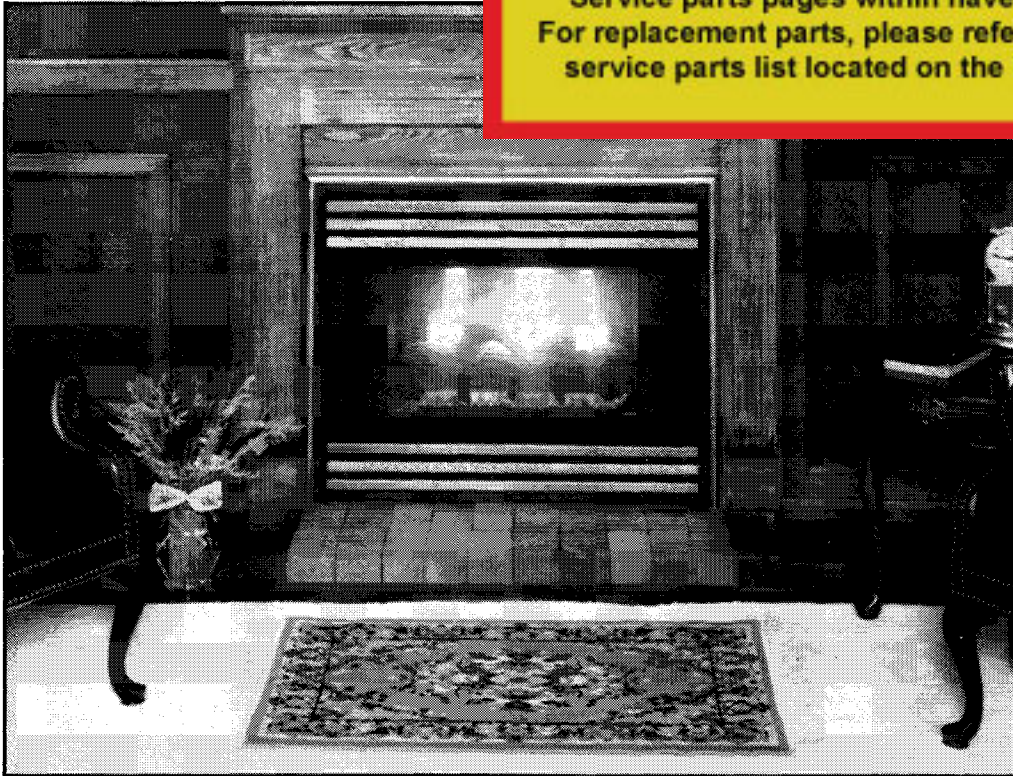

This appliance has been retired.
Service parts pages within have been removed.
For replacement parts, please refer to the individual
service parts list located on the brand websites.



U.S. PATENT 4,793,322 AND PATENTS PENDING

Model 5000GDV
Installation and Operation
Instructions
A.G.A. Design Certified
And
CGA Certified

THIS MANUAL MUST BE USED FOR INSTALLATION AND RETAINED BY THE HOMEOWNER FOR
OPERATION AND MAINTENANCE.

GAS TECHNOLOGIES, INC.
6665 W. Hwy 13 Savage, MN 55378 (612)890-8367

INSTALLATION AND OPERATION INSTRUCTIONS

PLEASE READ THIS MANUAL BEFORE INSTALLING AND USING THE FIREPLACE

MODEL 5000GDV IS A.G.A. DESIGN CERTIFIED AND CGA CERTIFIED FOR NATURAL GAS OR PROPANE

Requires one or more of the following vent systems for installation:

DVK-01A, DVK-01SA HORIZONTAL TERMINATION KITS
DVK-02A, DVK-02SA HORIZONTAL TERMINATION KITS
DVK-TVC, DVK-TVCD VERTICAL TERMINATION CAP

FOR YOUR SAFETY

What to do if you smell gas:

- Extinguish any open flame.
- Do not try to light any appliance.
- Do not touch any electrical switch; do not use any phone in your building.
- Immediately call your gas supplier from a neighbor's phone. Follow the gas supplier's instructions.
- If you cannot reach your gas supplier, call the fire department.

FOR YOUR SAFETY

Do not store or use gasoline or other flammable vapors and liquids in the vicinity of this or any other appliance.

WARNING: "IMPROPER INSTALLATION, ADJUSTMENT, ALTERATION, SERVICE OR MAINTENANCE CAN CAUSE INJURY OR PROPERTY DAMAGE. REFER TO THIS MANUAL. FOR ASSISTANCE OR ADDITIONAL INFORMATION CONSULT A QUALIFIED INSTALLER, SERVICE AGENCY OR THE GAS SUPPLIER."

IMPORTANT: Read all instructions carefully before starting installation. Failure to follow these installation instructions may result in a possible fire hazard and will void the warranty.

Save this Manual for future reference.

Copyright 1992, Gas Technologies, Inc. 6665 W. Hwy 13 Savage, MN 55378 Printed in U.S.A.

TABLE OF CONTENTS

1.0	Introduction	4
2.0	Installation Precautions	5
3.0	Installation Instructions	6
3.1	Vent System Approvals	8
3.1.1	Horizontal Terminating Vent Systems	13
3.1.2	Vertical Terminating Vent Systems	13
3.2	Vent System Installation Precautions	13
3.3	Installing Vent System Components	14
3.4	Cutting The Holes Through The Wall	16
3.5	Installing Wall Spacers	16
3.6	Permanently Anchoring The Fireplace	16
3.7	Connecting The Gas Line	17
3.8	Electrical Wiring For Optional Kits	17
3.8.1	Installing Electrical Service To The Junction Box	17
3.9	Wall Switch Wiring	19
3.10	Finishing	19
3.11	Hearth Extension	19
4.0	Electrical Safety System	20
5.0	Operating Guidelines/Maintenance Instructions	20
5.1	Glass Door Removal	21
5.2	Cleaning Burner And Pilot	21
5.3	Log Replacement	21
5.4	Glass Door Replacement	21
6.0	Safety Information	22
7.0	Lighting Instructions	23
	LPG (Propane) Information	24
8.0	High Altitude Installation	24
9.0	Trouble Shooting	25-28
10.0	Replacement Parts	29
	Warranty Information	30

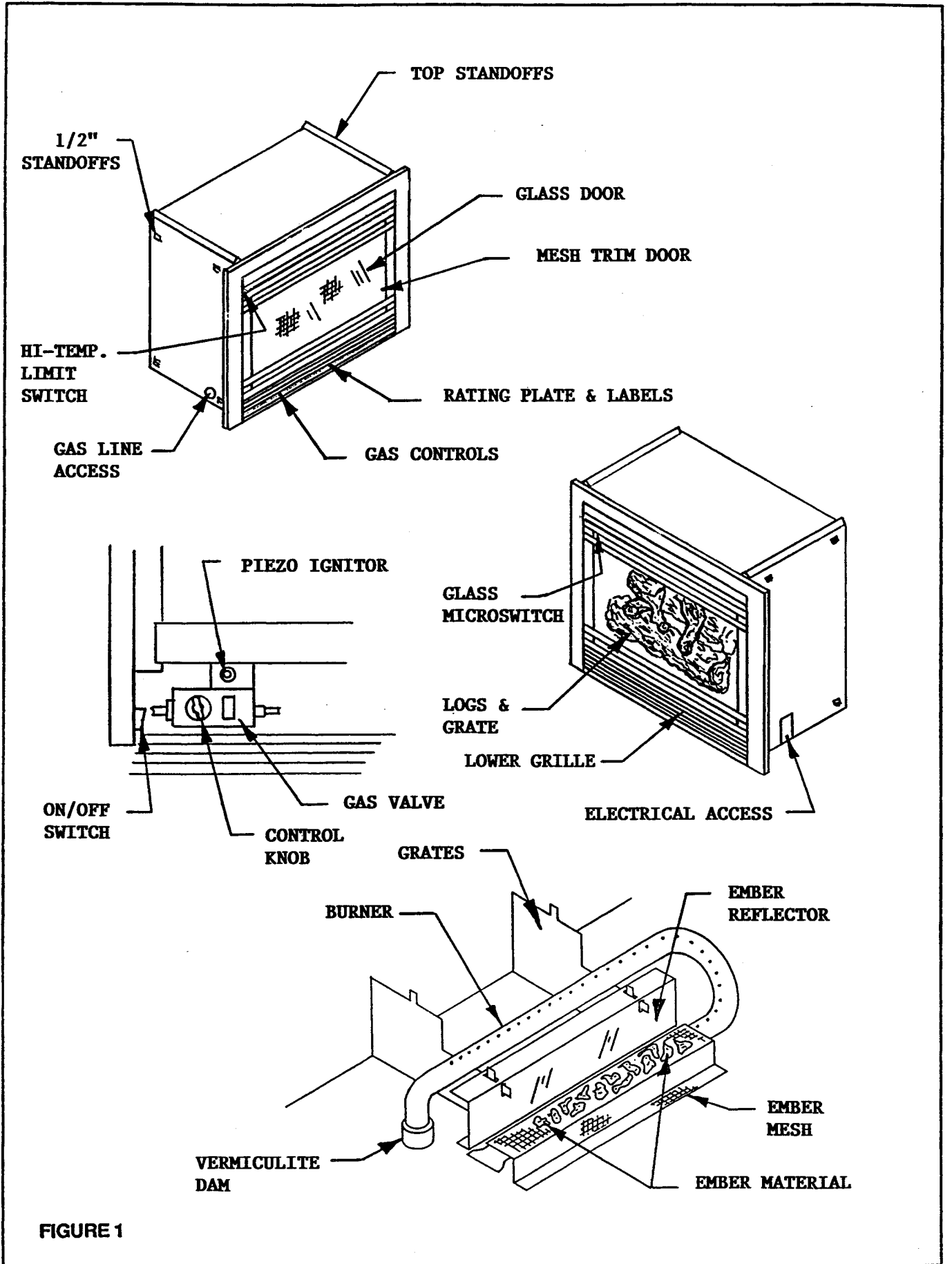

FIGURE 1

1.0 INTRODUCTION

Model 5000GDV is a Direct Vent Decorative Gas Appliance. It is designed to operate with all combustion air being siphoned from the outside of the building and all exhaust gases expelled to the outside of the building.

WARNING: THIS UNIT IS NOT FOR USE WITH SOLID FUEL.

The 5000GDV **MUST** use one of the vent terminations listed on page 1 and described in the venting section of this manual. **NO other vent terminations or components may be used unless described in these instructions.**

The control system for Model 5000GDV is a millivolt type. It consists of a gas control valve/regulator, a standing pilot assembly, a thermopile, a piezo ignitor, an ON/OFF rocker switch, a safety high temperature limit switch, and a safety microswitch for the sealed glass door. The controls are located in the lower compartment behind the grille. Access to this compartment is gained by rotating down the bottom grille. See Figure 1.

WARNING: DO NOT CONNECT 110-120 VAC TO THE GAS CONTROL VALVE OR CONTROL WIRING SYSTEM OF THIS UNIT.

Installation must conform to local codes. In the absence of local codes installation must conform with the current National Fuel Gas Code ANSI Z223.1 (in the United States) or with the current installation code CAN/CGA - B149 (in Canada).

The appliance when installed must be electrically grounded in accordance with local codes; in absence of local codes, with the current National Electric Code ANSI/NFPA NO. 70 (in the United States) or with the current CSA C22.1 Canadian Electric Code (in Canada).

NOTE: INSTALLATION AND REPAIR SHOULD BE DONE BY A QUALIFIED SERVICE PERSON. THE APPLIANCE SHOULD BE INSPECTED BEFORE USE AND AT LEAST ANNUALLY BY A PROFESSIONAL SERVICE PERSON. MORE FREQUENT CLEANING MAY BE REQUIRED DUE TO EXCESSIVE LINT FROM CARPETING, BEDDING MATERIAL, ETC. IT IS IMPERATIVE THAT THE UNIT'S CONTROL COMPARTMENT, BURNERS, AND CIRCULATING AIR PASSAGEWAYS BE KEPT CLEAN TO PROVIDE FOR ADEQUATE COMBUSTION AND VENTILATION AIR.

Provide adequate clearances around air openings into the combustion chamber and allow accessibility clearance for servicing and proper operation. NEVER OBSTRUCT THE FRONT OPENINGS OF THE FIREPLACE OR THE DIRECT VENT CAP ON THE EXTERIOR OF THE HOUSE.

Minimum clearances in inches to combustibles are: Glass Front 36, Floor 0, Back 1/2, Top 1/2 (top and back clearances are defined by the standoffs). Minimum distance from the ceiling to the top front of the unit is 31 inches. The back of the unit may be recessed 18-3/8 inches within combustible construction. Minimum clearance to a perpendicular wall extending past the front face of the unit is 1-inch.

Minimum inlet gas supply pressure for purpose of input adjustment is 4.5 inches water column natural gas and 11 inches water column propane. Maximum inlet gas supply pressure is 10.5 inches w.c. natural gas and 13.0 inches w.c. propane. For the purpose of input adjustment, inlet gas supply pressure should be 7.0 inches w.c. natural gas and 11.0 inches w.c. propane and manifold pressure should be set at 3.5 inches w.c. and 10.0 inches w.c. respectively.

A 1/8-inch N.P.T. plugged tapping is provided on the outlet side of the gas control for a test gauge connection to measure the manifold pressure. Provisions must be made to attach a test gauge to a 1/8-inch NPT plugged tapping immediately upstream of the gas supply connection to the appliance to measure inlet pressure.

The appliance and its individual shut off valve must be disconnected from the gas supply piping system during any pressure testing of the system at test pressures in excess of 1/2 psig (3.45 kPa).

This appliance must be isolated from the gas supply piping system by closing its individual manual shut-off valve during any pressure testing of the gas supply piping system at test pressures equal to or less than 1/2 psig (3.45 kPa).

2.0 INSTALLATION PRECAUTIONS

This direct vent gas fireplace and its components are tested and safe when installed in accordance with this Installation Manual. Report to your dealer any parts damaged in shipment, specifically check glass condition. The vent system and gas logs are in separate packages. Read all instructions before starting installation and follow these instructions carefully during installation to insure maximum benefit and safety. Failure to follow them will void your warranty and may present a fire hazard.

The Gas Technologies, Inc. warranty will be voided by, and Gas Technologies, Inc. disclaims any responsibility for, the following actions:

- Installation of any damaged fireplace or vent system component
- Modification of the fireplace or direct vent system
- Installation other than as instructed by Gas Technologies, Inc.
- Improper positioning of the gas logs or the glass door
- Installation and/or use of any component part not manufactured or approved by Gas Technologies, Inc., not withstanding any independent testing laboratory or other party approval of such component part or accessory.

ANY SUCH ACTION MAY POSSIBLY CAUSE A FIRE HAZARD.

Consult your local building codes.

NOTE: The appliance has an air-tight combustion chamber and takes 100% outside air for combustion. This appliance requires a direct vent system (see venting section of this manual for details). Both Natural Gas and Propane units may be installed in a bedroom.

THIS FIREPLACE AND VENT ASSEMBLY MUST BE VENTED THROUGH AN OUTSIDE WALL AND MUST NEVER BE ATTACHED TO A CHIMNEY SERVING A SOLID FUEL BURNING APPLIANCE.

NOTE: When installing the vent system, it is imperative that the vent cap (horizontal termination) be **NO** more than a 1/4" below horizontal.

Open the bag of vermiculite and spread it evenly on the bottom of the firebox making sure not to block the air hole at the base of the burner or the air holes in the center of the base pan (See Figure 1).

NOTE: It is essential for proper unit operation that the vermiculite contained in the plastic bag be spread evenly across the bottom of the firebox.

CAUTION: No vermiculite can be present in the area surrounded by the vermiculite dam at the base of the burner (See Figure 1).

Carefully spread a single layer of dime size and shape pieces of ember material (found in a separate bag) uniformly over the upper portion of the lower burner ember shield (Figure 1). The excess ember material should be used as replacement material during the annual servicing.

To install the logs, remove the front mesh trim and glass door assemblies. Place the bottom front and rear logs on the grates using the holes in the bottom of the logs and the tabs on the grates. (See Figure 2). Position the middle right and left logs in the cut-out areas on top of the bottom logs. Place the top right and left twigs in the flat cut-out areas on top of the middle logs.

WARNING: THE GAS LOGS MUST BE PROPERLY POSITIONED, WITH NO FLAME IMPINGEMENT ON THEM, OR THE FIREPLACE WILL NOT FUNCTION PROPERLY AND MAY RESULT IN SOOT ACCUMULATION ON THE INSIDE OF THE FIREBOX. IF THE BURNER FLAME IMPINGES ON THE LOGS, REPOSITION THEM SO THAT NO IMPINGEMENT OCCURS.

Replace the glass door and mesh trim assemblies. **THE UNIT WILL NOT OPERATE UNLESS THE GLASS DOOR IS SECURED IN PLACE AND SEALED.**

WARNING: DO NOT OPERATE THIS APPLIANCE WITH THE GLASS DOOR REMOVED, CRACKED, OR BROKEN. REPLACEMENT OF THE GLASS DOOR SHOULD BE DONE BY A LICENSED OR QUALIFIED PERSON. DO NOT STRIKE OR SLAM THE GLASS DOOR.

WARNING: THE GLASS DOOR ASSEMBLY SHALL ONLY BE REPLACED AS A COMPLETE UNIT AS SUPPLIED BY THE GAS FIREPLACE MANUFACTURER. NO SUBSTITUTE MATERIALS MAY BE USED.

WARNING: THE GLASS DOOR ASSEMBLY MUST BE IN PLACE AND SEALED AND THE FIXED MESH TRIM ASSEMBLY MUST BE IN PLACE ON THE FIREPLACE BEFORE THE UNIT CAN BE PLACED INTO SAFE OPERATION.

Prior to first firing, read Operation Instructions section of this manual.

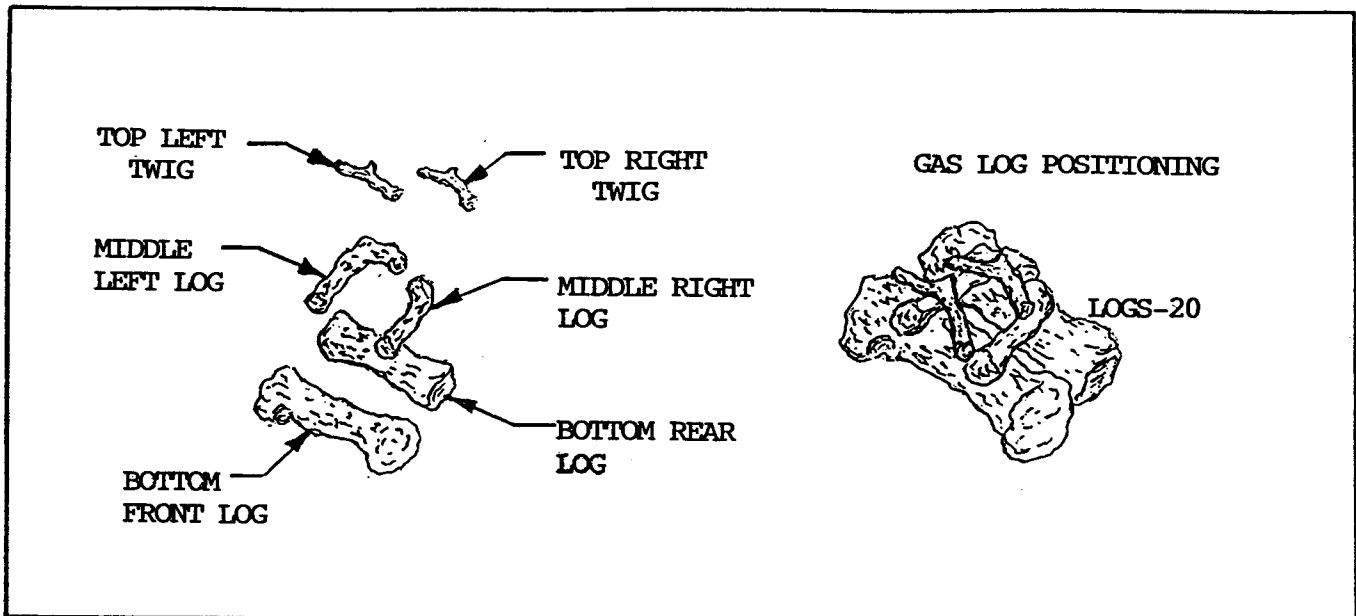

FIGURE 2

Do not use this appliance if any part has been under water. Immediately call a qualified service technician to inspect the unit and to replace any part of the control system and any gas control which has been underwater.

DUE TO HIGH TEMPERATURE, THE APPLIANCE SHOULD BE LOCATED OUT OF TRAFFIC AREAS AND AWAY FROM FURNITURE AND DRAPERIES. CLOTHING OR FLAMMABLE MATERIAL SHOULD NOT BE PLACED ON OR NEAR THE APPLIANCE.

NOTE: IF EXTERIOR WALLS ARE FINISHED WITH VINYL SIDING, IT IS NECESSARY TO INSTALL THE VINYL PROTECTOR KIT (VPK-DV) TO THE TOP OF THE EXTERIOR FIRESTOP.

3.0 INSTALLATION INSTRUCTIONS

In planning the installation for the fireplace it is necessary to determine where the unit is to be installed, the type of vent system to be used (straight out, corner, or elevated), and whether optional accessories (fan, wall switch or remote control) are desired. Gas supply piping should also be planned.

The fireplace can be mounted on any of the following surface:

1. A flat combustible surface other than carpeting.
2. A raised wooden platform.
3. Four (4) corner supports.

(Example: Four (4) concrete masonry blocks). These supports must be positioned so they contact all four (4) perimeter edges on the bottom of the unit.

If the fireplace is installed directly on carpeting, tile, or other combustible material other than wood flooring, the appliance shall be installed on a metal or wood panel extending the full width and depth of the unit.

Fireplace framing can be built before or after the fireplace is set in place. Framing should be positioned to accommodate wall covering and fireplace facing material. The fireplace framing should be constructed of 2 X 4 lumber or heavier. The framing headers may rest on the fireplace standoffs. Refer to Figure 3 and Figure 4 for fireplace and framing reference dimensions. **CAUTION:** Measure fireplace dimensions, and verify framing methods and wall covering details before framing construction begins.

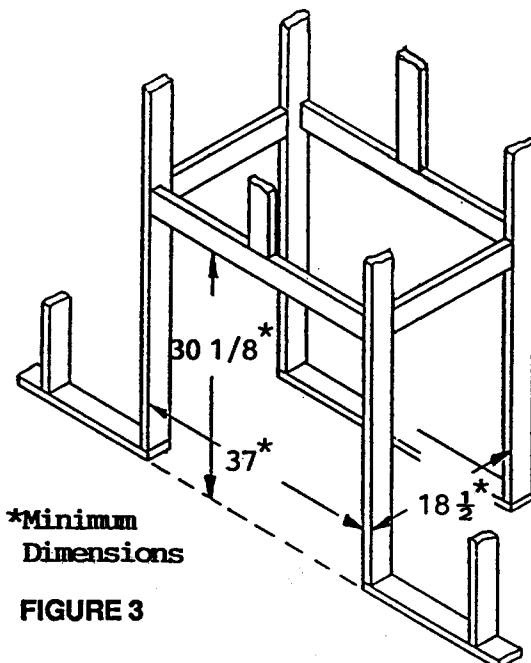

FIGURE 3

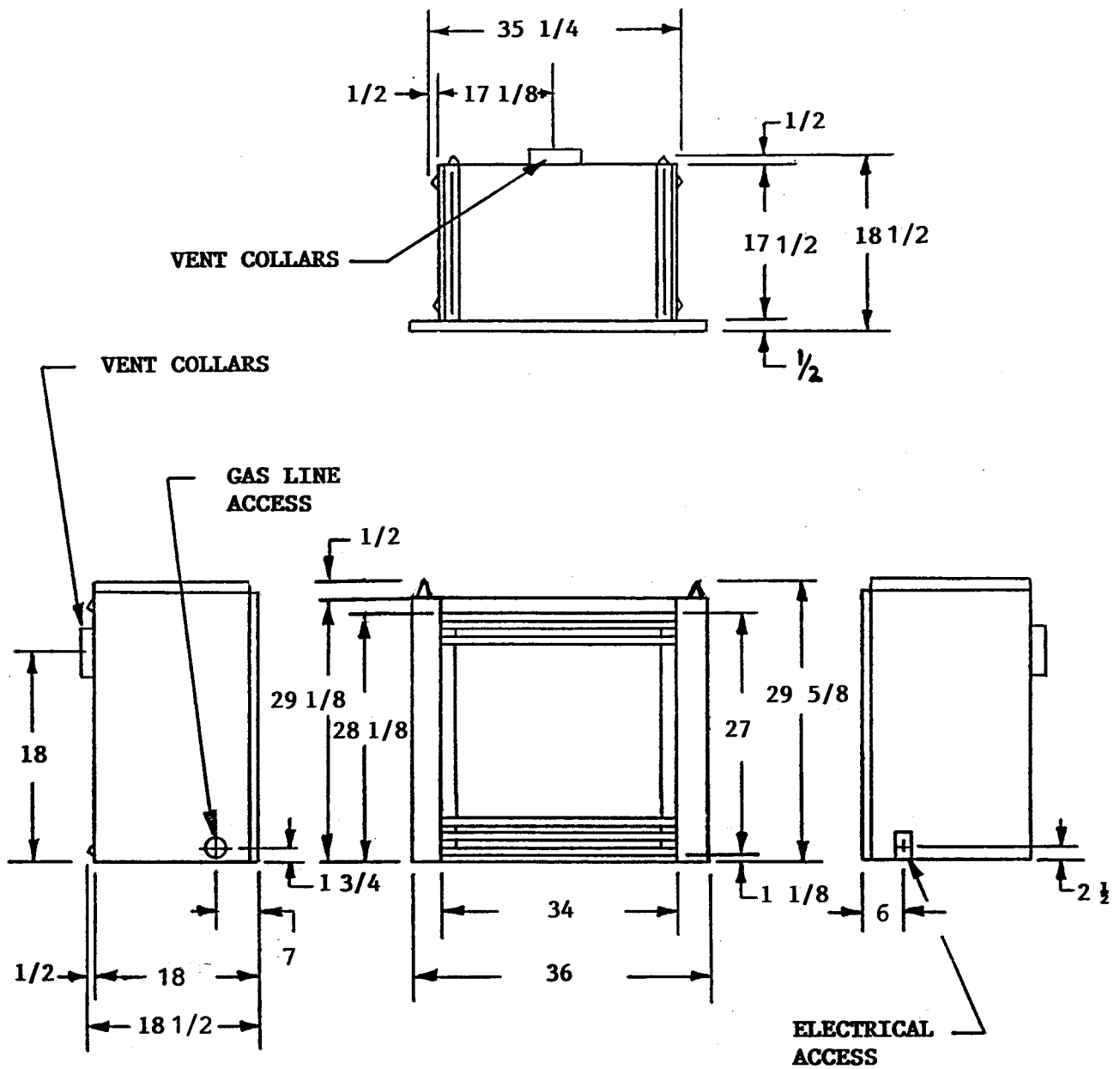

FIGURE 4

MODEL	VENT TERMINATION APPROVALS				
5000GDV	DVK-01A	DVK-02A	DVK-01SA	DVK-02SA	DVK-TVC DVK-TVCD

TABLE 1

3.1 VENT SYSTEM APPROVALS

Tables 1 through 6 and Figures 5 through 8 show the vent systems approved for use with Model 5000GDV. Approved vent system components are labeled for identification. **NO OTHER VENTING SYSTEMS OR COMPONENTS MAY BE USED.** Detailed installation instructions are included with each vent termination kit and should be used in conjunction with this manual.

HORIZONTAL VENTING

Table 2 and Figure 5 show the horizontal vent termination kits approved for use on this model.

ELBOWS

The vent systems installed on this gas fireplace may also include one (1), two (2), or three (3) 90-degree elbow assemblies. The following relationships of vertical rise to horizontal run in vent configurations using 90-degree elbows **MUST** be strictly adhered to.

NOTE: 45-DEGREE ELBOWS (DVK-45) MAY BE USED IN PLACE OF 90-DEGREE ELBOWS.

ONE (1) 90-DEGREE ELBOW

Figure 6 and Table 3 show examples of possible installations using one (1) 90-degree elbow. Dimension V is listed as **MINIMUM** vertical dimensions and dimension H is listed as corresponding **MAXIMUM** horizontal dimensions. Vertical dimensions are based on centerline of pipe to end of termination. Horizontal dimensions are based on back of unit to centerline of pipe. A vent system using one 90-degree elbow will result in a vertical termination.

If straight sections of vent pipe are first attached to the unit, there must be at least a 1-foot vertical rise for each 2-feet of horizontal run. The maximum vertical rise is 40-feet, and the maximum horizontal run is 8-feet.

TWO (2) 90-DEGREE ELBOWS

Figure 7 and Table 4 show examples of possible installations using two (2) 90-degree elbows. Dimension V is listed as **MINIMUM** vertical dimensions, dimension H is listed as **MAXIMUM** beginning horizontal dimensions, and dimension H+H₁ is listed as corresponding **TOTAL MAXIMUM** horizontal dimensions. Vertical dimensions are based on centerline to centerline of pipe. Horizontal dimensions H are based on back of unit to centerline of pipe. Horizontal dimensions H₁ are based on centerline of pipe to end of termination.

Elevated vent systems using two (2) 90-degree elbows, **MUST** have at least a 1-foot vertical rise for each 6-feet of horizontal run. The **MAXIMUM** vertical rise is 20-feet and the **MAXIMUM** beginning horizontal run H is 8-feet. The **MAXIMUM TOTAL** horizontal run H+H₁ is 24 feet (20-feet in Canada). A vent system using two 90-degree elbows will result in a horizontal termination.

THREE (3) 90-DEGREE ELBOWS

Figure 8 and Table 5 show examples of possible installations using three (3) 90-degree elbows and a horizontal termination. Figure 8 and Table 6 show examples of possible installations using three (3) 90-degree elbows and a vertical termination. Dimensions V are listed **MINIMUM** first vertical dimensions and dimensions H are listed as beginning **MAXIMUM** horizontal dimensions. Dimensions H+H₁ (vertical termination) and H+H₁+H₂ (horizontal termination) are listed as **TOTAL MAXIMUM** horizontal dimensions. A vent system using three (3) 90-degree elbows can terminate either horizontally or vertically.

Elevated vent systems using three (3) 90-degree elbows **MUST** maintain the following relationships.

1. There **MUST** be at least a 1-foot vertical rise V for each 2-feet of beginning horizontal run H .
2. There **MUST** be at least a 1-foot total vertical rise V or $V+V_1$ for each 5-feet of total horizontal run $H+H_1$ or $H+H_1+H_2$.

3. The **MAXIMUM** vertical rise V is 20-feet, the **MAXIMUM** beginning horizontal run H is 8-feet, and the **MAXIMUM TOTAL** horizontal run $H+H_1+H_2$ is 20-feet for systems terminating horizontally. (See Table 5)

4. The **MAXIMUM** beginning horizontal run H is 8-feet and the **TOTAL MAXIMUM** horizontal run $H+H_1$ is 20-feet for systems terminating vertically. The **TOTAL MAXIMUM** vertical rise $V+V_1$ is 40-feet. (See Table 6)

HORIZONTAL VENTING		
KIT NO.	H MIN. RUN	H MAX. RUN
DVK-01A DVK-01SA	8"	13"
DVK-02A DVK-02SA	13.1"	24"

TABLE 2

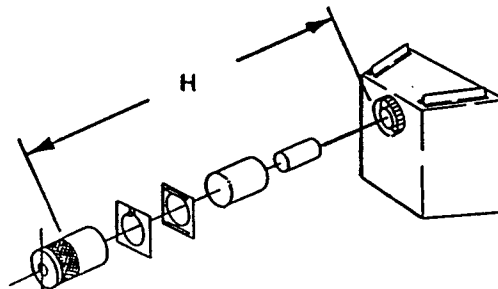

FIGURE 5

VENTING WITH ONE (1) 90° ELBOW	
V (FT.)	H (FT.)
1' MINIMUM	2' MAXIMUM
2' MINIMUM	4' MAXIMUM
3' MINIMUM	6' MAXIMUM
4' MINIMUM	8' MAXIMUM
5' MINIMUM	8' MAXIMUM
40' MAXIMUM	8' MAXIMUM

TABLE 3

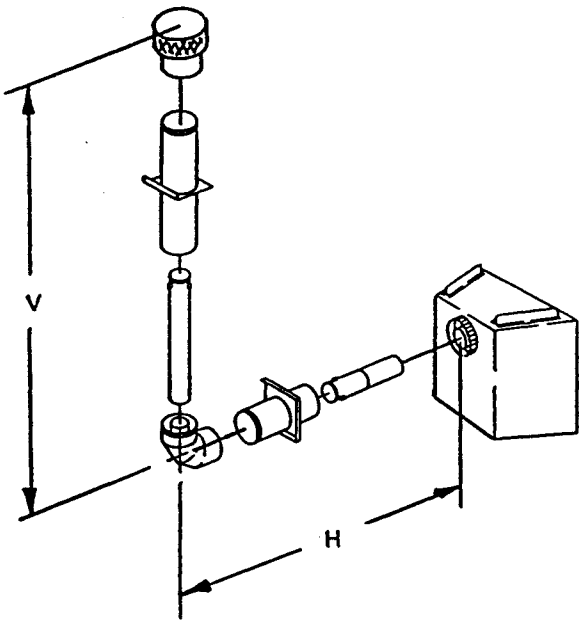

FIGURE 6

VENTING WITH TWO (2) 90° ELBOWS		
V (FT.)	H (FT.)	H+H ₁ (FT.)
1' MIN.	2' MAX.	6' MAX.
2' MIN.	4' MAX.	12' MAX.
3' MIN.	6' MAX.	18' MAX.
4' MIN.	8' MAX.	24' MAX.
5' MIN.	8' MAX.	24' MAX.
20' MAX.	8' MAX.	24' MAX. (20' IN CANADA)

TABLE 4

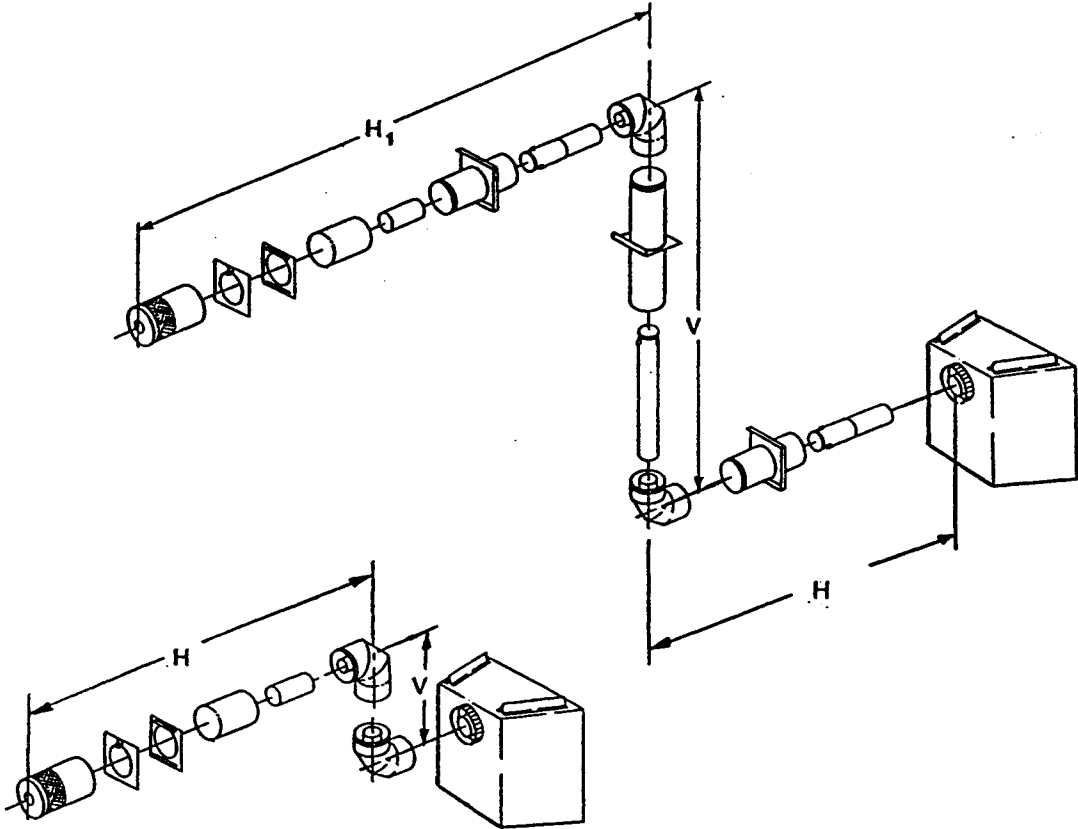
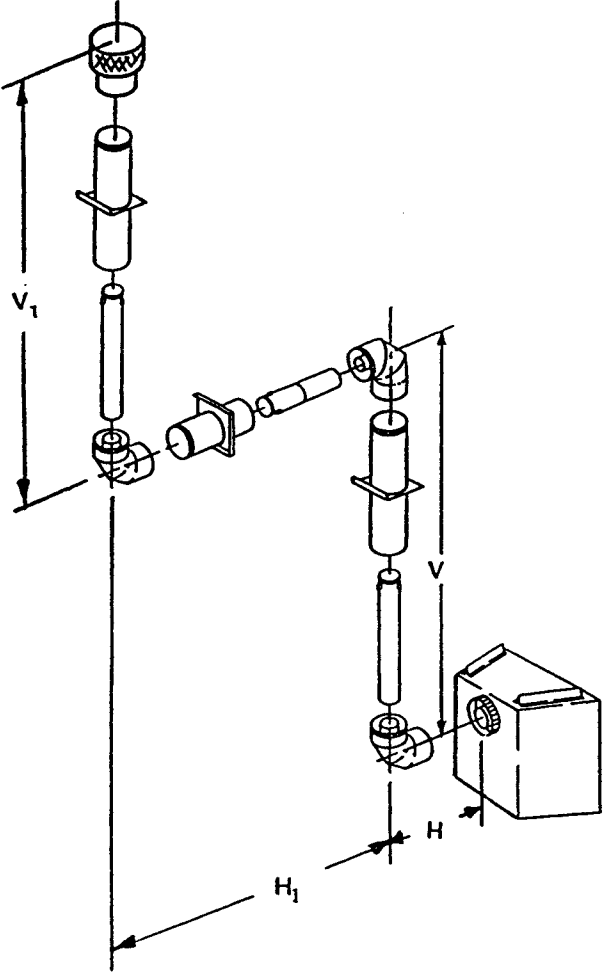
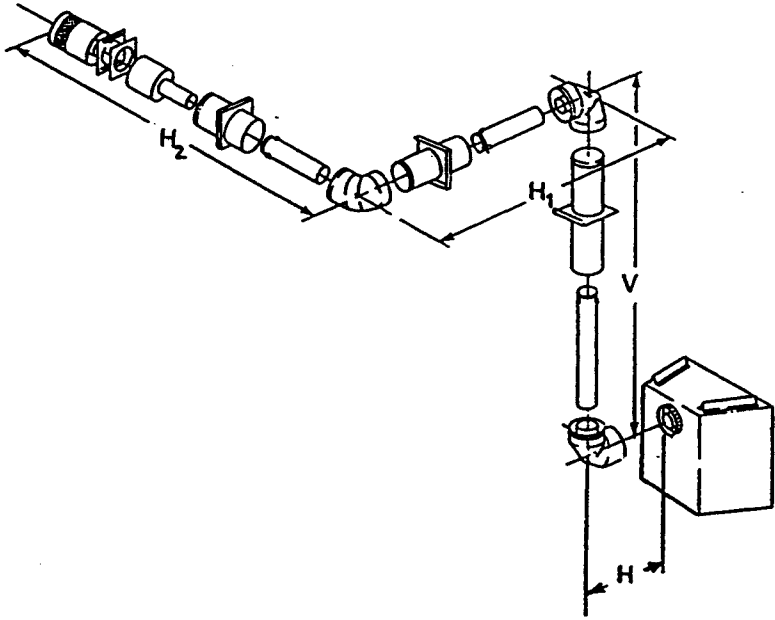

FIGURE 7

VENTING WITH THREE (3) 90° ELBOWS		
V (FT.)	H (FT.)	H+H ₁ +H ₂ (FT.)
1' MIN.	2' MAX.	5' MAX.
2' MIN.	4' MAX.	10' MAX.
3' MIN.	6' MAX.	15' MAX.
4' MIN.	8' MAX.	20' MAX.
5' MIN.	8' MAX.	20' MAX.
20' MAX.	8' MAX.	20' MAX.

TABLE 5



VENTING WITH THREE (3) 90° ELBOWS		
V (FT.)	H (FT.)	H+ H ₁ (FT.)
1' MIN.	2' MAX.	5' MAX.
2' MIN.	4' MAX.	10' MAX.
3' MIN.	6' MAX.	15' MAX.
4' MIN.	8' MAX.	20' MAX.
5' MIN.	8' MAX.	20' MAX.
	8' MAX.	20' MAX.

NOTE: V+ V₁ MAX. 40'

TABLE 6

3.1.1 HORIZONTAL TERMINATING VENT SYSTEMS

DVK-01A, DVK-02A, DVK-01SA and DVK-02SA are telescoping vent kits which are used to terminate a vent system in a horizontal position. DVK-01A and DVK-02A have pre-assembled round termination caps - DVK-01SA and DVK-02SA have pre-assembled square termination caps.

NOTE: A Model DRC-DV shield **MUST** be installed with DVK-01A or DVK-02A termination kits in Canada.

3.1.2 VERTICAL TERMINATING VENT SYSTEMS

DVK-TVC or DVK-TVCD are vertical termination caps which must be used to terminate vent systems in a vertical position.

WARNING: Major U.S. building codes specify minimum chimney and/or vent height above the roof top. These minimum heights are necessary in the interest of safety. These specifications are summarized in the Ten Foot Rule (See Fig. 9). The key points of this rule are:

1. If the horizontal distance from the edge of the vent or chimney to the peak of the roof is 10 feet or less, the top of the vent or chimney must be at least 2 feet above the peak of the roof, but never less than 3 feet in height above the highest point where it passes through the roof.
2. If a horizontal distance from the edge of the vent or chimney to the peak of the roof is more than 10 feet, a vent or chimney height reference point is established that is on the surface of the roof a distance of 10 feet from the edge of the vent or chimney in a horizontal plane. (See Fig. 9) The top of the vent or chimney must be at least 2 feet above this reference point, but never less than 3 feet in height above the highest point where it passes through the roof.

NOTE: THIS ALSO PERTAINS TO VERTICAL VENT SYSTEMS INSTALLED ON THE OUTSIDE OF THE BUILDING.

3.2 VENT SYSTEM INSTALLATION PRECAUTIONS

Before starting installation of vent kits, the installer should read the Gas Fireplace Instructions and the Vent Kit Instructions to insure that the proper vent system has been selected for the installation.

Determine the exact position of the fireplace so the direct vent pipe is centered (if possible) between two building framing members. This will avoid any extra framing. Using a level, make sure the fireplace is properly positioned and squared. The 1/2 inch standoffs on the sides and back of the fireplace may be positioned directly against combustible walls.

Consult your local Building Codes before beginning the installation.

WARNING: THIS GAS FIREPLACE AND VENT ASSEMBLY **MUST** BE VENTED DIRECTLY TO THE OUTSIDE AND **MUST** NEVER BE ATTACHED TO A CHIMNEY SERVING A SEPARATE SOLID FUEL BURNING APPLIANCE. EACH GAS APPLIANCE **MUST** USE A SEPARATE VENT SYSTEM-COMMON VENT SYSTEMS ARE PROHIBITED.

CAUTION: UNDER NO CONDITION SHOULD COMBUSTIBLE MATERIAL BE CLOSER THAN 3 INCHES FROM THE TOP OF THE 8-INCH PIPE OR 1-INCH TO THE SIDES AND THE BOTTOM FOR HORIZONTAL SECTIONS OF THIS VENT SYSTEM. VERTICAL SECTIONS OF THIS SYSTEM REQUIRE A MINIMUM OF 1-INCH CLEARANCE TO COMBUSTIBLE MATERIALS ALL AROUND THE 8-INCH PIPE.

Connections between each vent system component must be properly and tightly joined, and system components must be secured with sheetmetal screws at each joint. THE PIPE SEAMS SHOULD BE DOWN ON HORIZONTAL SECTIONS OF THIS SYSTEM.

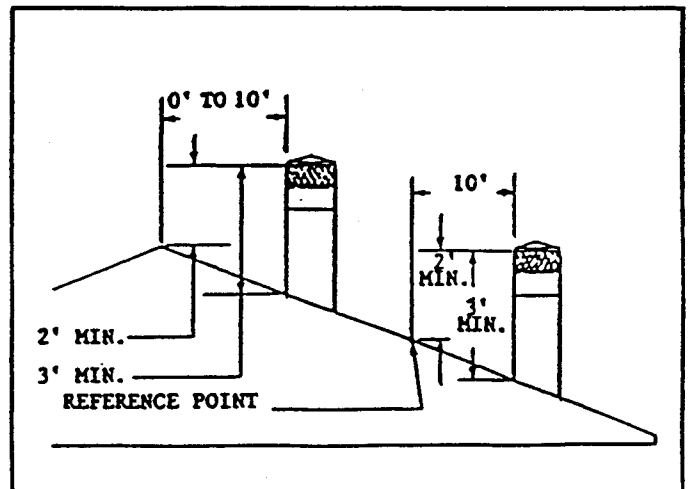

FIGURE 9

3.3 INSTALLING VENT SYSTEM COMPONENTS

Attach the first vent component to the starting collars of the fireplace. If the first vent component is a 90-degree elbow assembly (DVK-90), secure the 8-inch collar-elbow connection with three (3) sheetmetal screws. If the first vent component is concentric 5-inch and 8-inch straight pipe (DVK-36), secure the 5-inch inner pipe to the unit FIRST. Slide the 8-inch outer pipe over the 5-inch pipe and secure the pipe to the 8-inch starting collar with a minimum of three (3) sheetmetal screws.

WARNING: MAKE CERTAIN THAT THE ELBOW ASSEMBLY OR STRAIGHT PIPE SECTION IS PUSHED ALL THE WAY ONTO THE STARTING COLLARS AND IS SECURELY FASTENED.

Continue adding vent components per the pre-planned system configuration. If the vent system is to terminate horizontally through a side wall, add components until the vent system is just short of the wall. Read and complete Sections 3.4 CUTTING THE HOLE THROUGH THE EXTERIOR WALL and 3.5 INSTALLING WALL SPACERS before continuing the installation.

Install the horizontal termination kit chosen to the last section of vent system installed. First attach the 5-inch inner pipe of the termination kit to the crimped end of the last vent section - and be certain that the pipe seam is facing down. Next, attach the 8-inch inner pipe to the last vent section, securing it with three (3) equally spaced sheetmetal screws. Slide the termination cap through the inner firestop and adjust it to its final position on the exterior of the building. See Figure 10. For round cap termination kits, use the exterior pipelock tab provided on the exterior firestop to secure the 8-inch pipe in place. For square cap termination kits, secure the cap to the exterior wall through the flanges built into the cap. Use a high temperature fiberglass rope gasketing to seal between the 8-inch pipe and the exterior firestop spacer.

NOTE: THE TERMINATION CAP MUST BE POSITIONED SO THAT THE VENT HOLES ARE ON THE BOTTOM AND THE ARROW IS POINTING UP. (SEE FIGURE 10).

If the vent system is to terminate vertically, proper minimum clearances and installation procedures for vertically terminating vent systems must be observed. Refer to SECTION 3.1.2 of this instruction manual and the detailed installation instructions found in the DVK-TV or DVK-TVCD termination cap kit.

NOTE: SUPPORT SPACERS (DVK-SPS) MUST BE USED FOR EACH 5-FEET OF VERTICAL AND HORIZONTAL RUN. THE SPACERS ARE PLACED AROUND THE 8-INCH DIAMETER PIPE AND NAILED OR SCREWED TO FRAMING MEMBERS.

WARNING: HORIZONTAL RUN SECTIONS MUST BE LEVEL AND PARALLEL WITH THE BASE OF THE FIREPLACE. UNDER NO CONDITION SHOULD COMBUSTIBLE MATERIAL BE CLOSER THAN 3-INCHES FROM THE TOP OF THE 8-INCH PIPE OR 1-INCH TO SIDES AND BOTTOM FOR HORIZONTAL RUN SECTIONS OF THIS VENT SYSTEM. A 1-INCH CLEARANCE TO COMBUSTIBLE MATERIALS ALL AROUND THE 8-INCH PIPE MUST BE MAINTAINED FOR VERTICAL RISE SECTIONS.

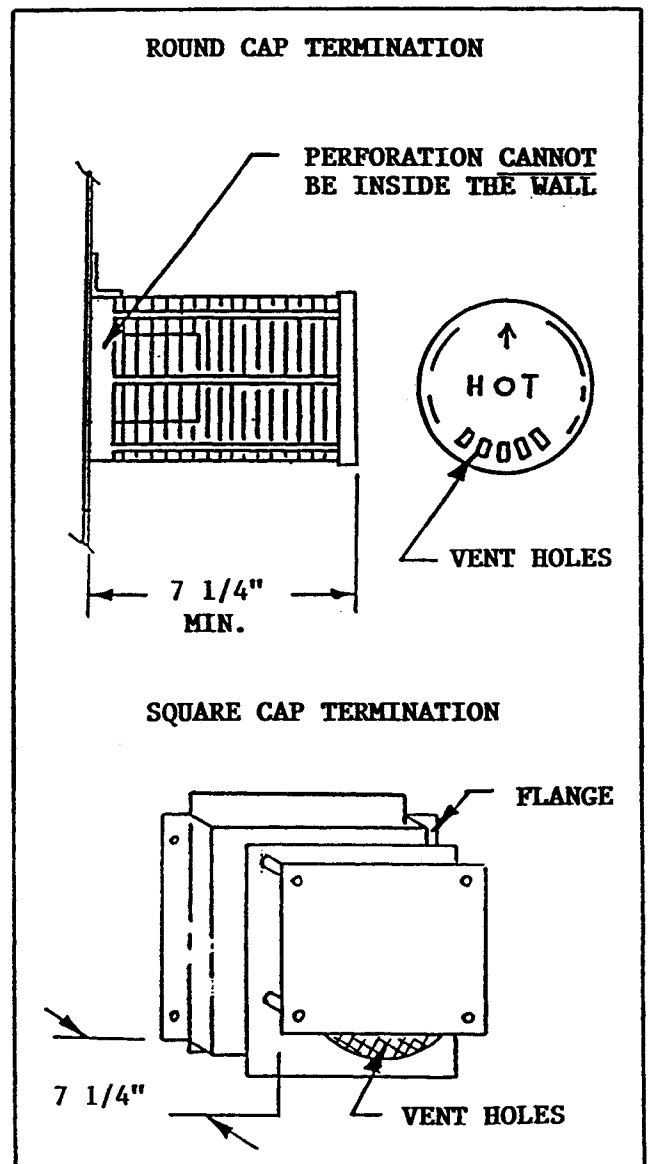
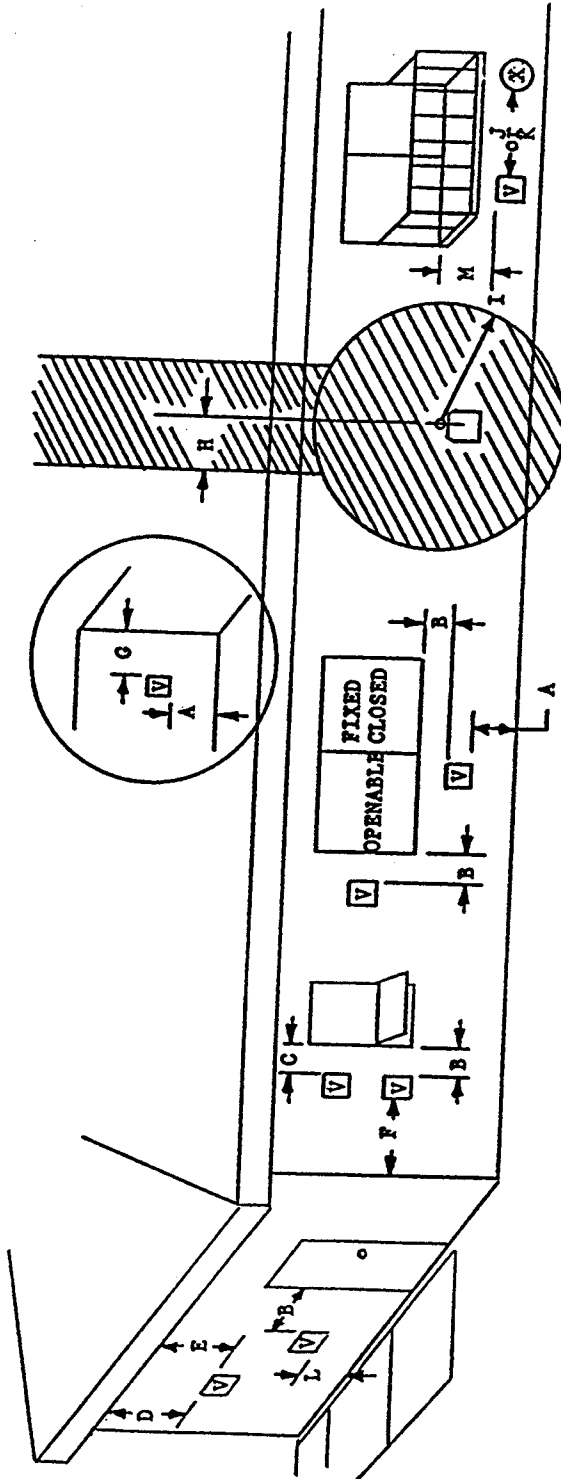

FIGURE 10

VENT TERMINATION MINIMUM CLEARANCES FOR MODEL 5000GDV (GDV-HSI)



V = vent terminal

X = air supply inlet

= area where terminal is not permitted

- A = 12"
- B = 12"
- C = 9"
- D = 18"

(U.S.A.)
(Canada)

- E = 18"
- F = 9"
- G = 6"

clearances above grade, veranda, porch, deck or balcony
clearance to window or door that may be opened
clearance to permanently closed window

vertical clearance to ventilated soffit located above the terminal within
a horizontal distance of 2 feet (60 cm) from the centre-line of the terminal
clearance to unventilated soffit
clearance to outside corner
clearance to inside corner

H = 3 feet

I = 3 feet (U.S.A.)
6 feet (Canada)

J = 9" (U.S.A.)
12" (Canada)

K = 3 feet (U.S.A.)
6 feet (Canada)

L = 7 feet
M = 18"

not to be installed above a meter/regulator assembly within 3 feet
(90 cm) horizontally from the centre-line of the regulator
clearance to service regulator vent outlet

clearance to non-mechanical air supply inlet to building or the combustion
air inlet to any other appliance
clearance to a mechanical air supply inlet

clearance above paved side-walk or a paved driveway located on public property
clearance under veranda, porch, deck or balcony

- a vent shall not terminate directly above a side-walk or paved driveway which is located between two single family dwellings and serves both dwellings.
- ** only permitted if veranda, porch, deck or balcony is fully open on a minimum of 2 sides beneath the floor.

NOTE: local Codes or Regulations may require different clearances

FIGURE 11

3.4 CUTTING THE HOLE THROUGH THE EXTERIOR WALL

Locate the center of a 12-inch square hole, which must be cut through the exterior wall of the building, by carefully measuring vertically from the base of the fireplace up to the center of the last section of horizontal vent run in the vent system. Add 1-inch to the vertical measurement obtained and mark this center-point on the wall. When locating this hole it must be noted that the bottom of the vent termination cap must be a **MINIMUM** of 12-inches above ground level (grade), the top of the cap must be a **MINIMUM** of 18-inches below combustible material such as a deck and the side of the cap must be a **MINIMUM** of 6-inches away from a parallel outside wall. See Figure 11 for Vent Termination Clearances.

3.5 INSTALLING WALL SPACERS

Position the interior firestop over the 12-inch hole on the inside wall (Figure 12). Make sure that the spacer is put in properly (with arrows pointing up). For walls less than 8-inches thick, the pipe shield will have to be trimmed back to a flush position. The exterior firestop should be installed once the unit is permanently positioned and anchored. (Section 3.6)

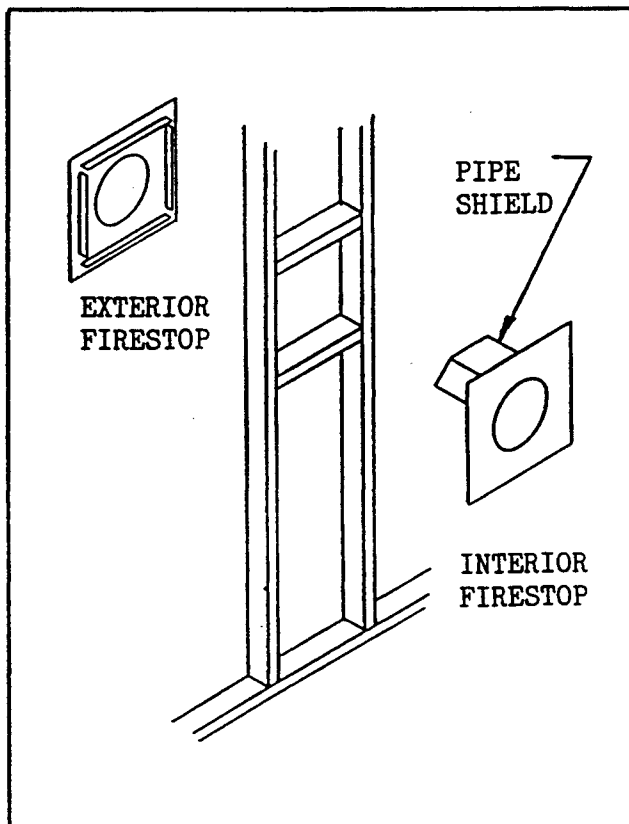

FIGURE 12

UNDER NO CONDITIONS SHOULD COMBUSTIBLE MATERIAL (INCLUDING SIDING) BE CLOSER THAN 3 INCHES TO THE TOP OF THE 8-INCH PIPE OR CLOSER THAN 1 INCH ON THE SIDES AND BOTTOM.

3.6 PERMANENTLY ANCHORING THE FIREPLACE

To prevent the unit from shifting, the fireplace must be anchored. Two methods are possible: use the nailing tabs shown in Figure 13, or use the standoffs on the top of the fireplace. A nail may be driven through or a screw inserted through the framing headers into the top standoffs as shown in Figure 13.

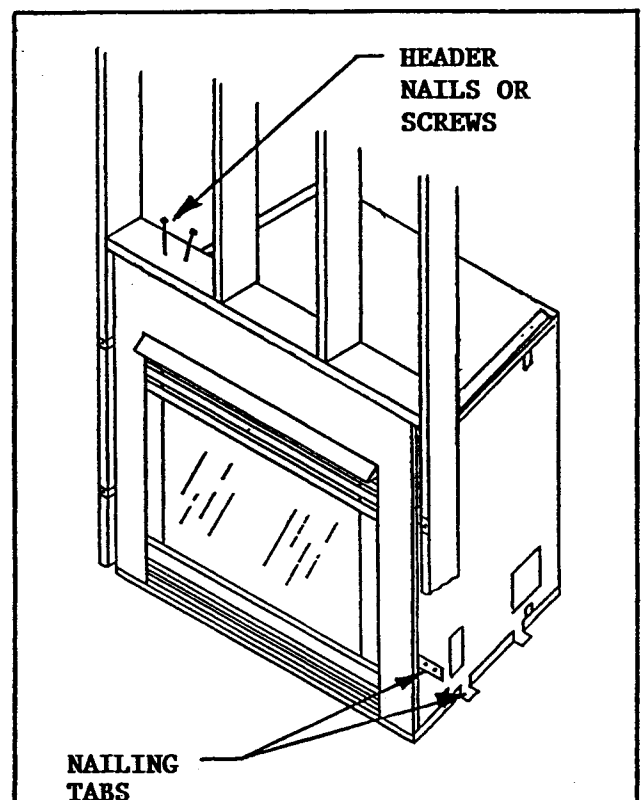

FIGURE 13

The exterior firestop (8-inch-diameter hole) may now be placed over the pipe on the outside of the house and nailed in position, again the arrows must point up to provide proper clearances. When finished, the cap should be as shown in Figure 10, with the cap extended past the exterior firestop a **MINIMUM** dimension as shown. The cap **MUST** be positioned with the vent holes on the bottom and the arrow pointing **UP**.

3.7 CONNECTING THE GAS LINE

The gas fireplace is designed to accept a 3/8 inch gas line for a listed gas appliance. Have the gas line installed by a qualified service person in accordance with all building codes. Consult local building codes to properly size the gas supply line leading to the 3/8 inch reduction for hook-up at the unit. It is recommended to assemble a gas pipe train as shown in Figure 14.

Use a 3/8" nipple, "T", union, and male/female manual gas shutoff valve. A 1/8" N.P.T. plugged tapping, accessible for test gauge connection, should also be provided for, in the pipe train. Locate the gas line access hole in the rear outer casing of the fireplace (Figure 14).

Next, insert the gas pipe train through the gas line hole from the outside of the fireplace and connect it to the gas valve. Support the control when attaching the pipe so that the pilot line is not bent or torn. After the gas pipe installation is complete, check carefully all gas connections for leaks with a soap solution. **DO NOT USE AN OPEN FLAME.**

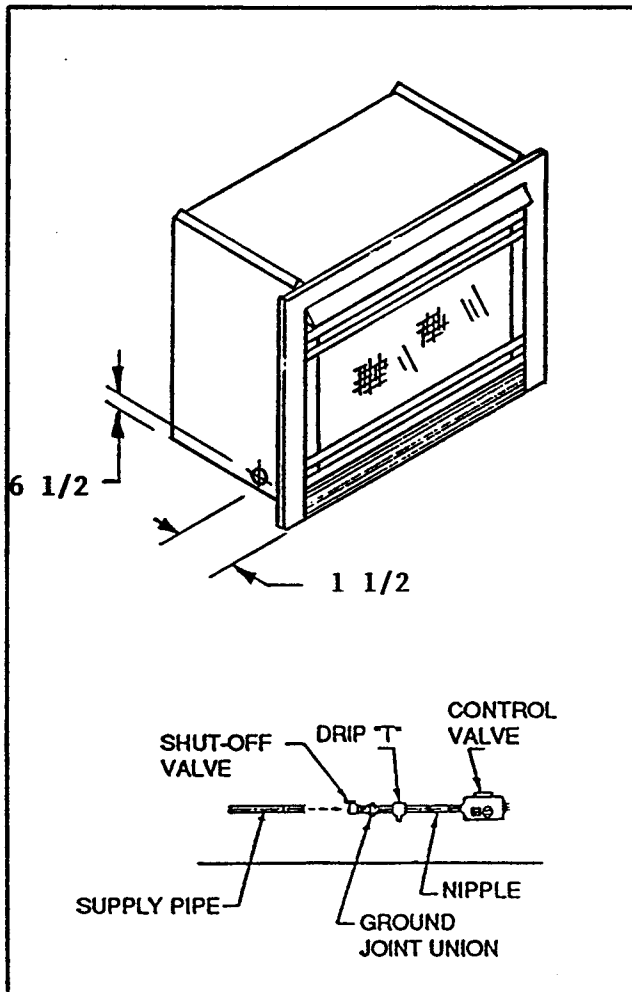

FIGURE 14

Use insulation to repack the space around the pipe. This should be inserted from the outside of the fireplace and packed tightly to totally seal between the pipe and the outer casing.

NOTE: THE GAS PIPE SHOULD NOT COME IN CONTACT WITH ANY WOOD STRUCTURES UNTIL IT HAS REACHED A POINT AT LEAST 1 INCH AWAY FROM THE FIREPLACE SIDE.

NOTE: THE GAS SUPPLY LINE SHOULD BE PURGED OF ANY TRAPPED AIR PRIOR TO THE FIRST FIRING OF THE UNIT.

3.8 ELECTRICAL WIRING FOR OPTIONAL KITS

Model 5000GDV Gas Fireplaces have factory installed Electrical Junction Boxes which are used ONLY for wiring in optional kits.

An optional blower kit with a magnetic blower mount (GFK-160A) and hand held remote control kit (RCH-09A) are available. Use of these options requires that the Junction Box (factory installed) be connected to 110 VAC service before permanently enclosing the fireplace. The access hole for connecting the 110 VAC service wires is found on the lower front exterior side of the unit. See Figure 15.

3.8.1 INSTALLING ELECTRICAL SERVICE TO THE JUNCTION BOX

WARNING: TURN ELECTRICAL POWER OFF AT THE CIRCUIT BREAKER BEFORE BEGINNING INSTALLATION.

1. Remove the electrical cover plate from the lower rear of the fireplace. Remove the knockout from the plate and attach the Romex clamp (screws to the outside).
2. Feed the electrical service wires through the Romex clamp and secure the wires to the clamp.
3. Using the wire nuts provided, connect the service wires to the Junction Box. The black wire to the black service wire, the white wire to the white service wire, and the service ground wire to the ground stud of the Junction Box.
4. Re-attach the cover plate to the outside of the fireplace.

Detailed instructions for the optional blower and the optional remote kits are included with each kit.

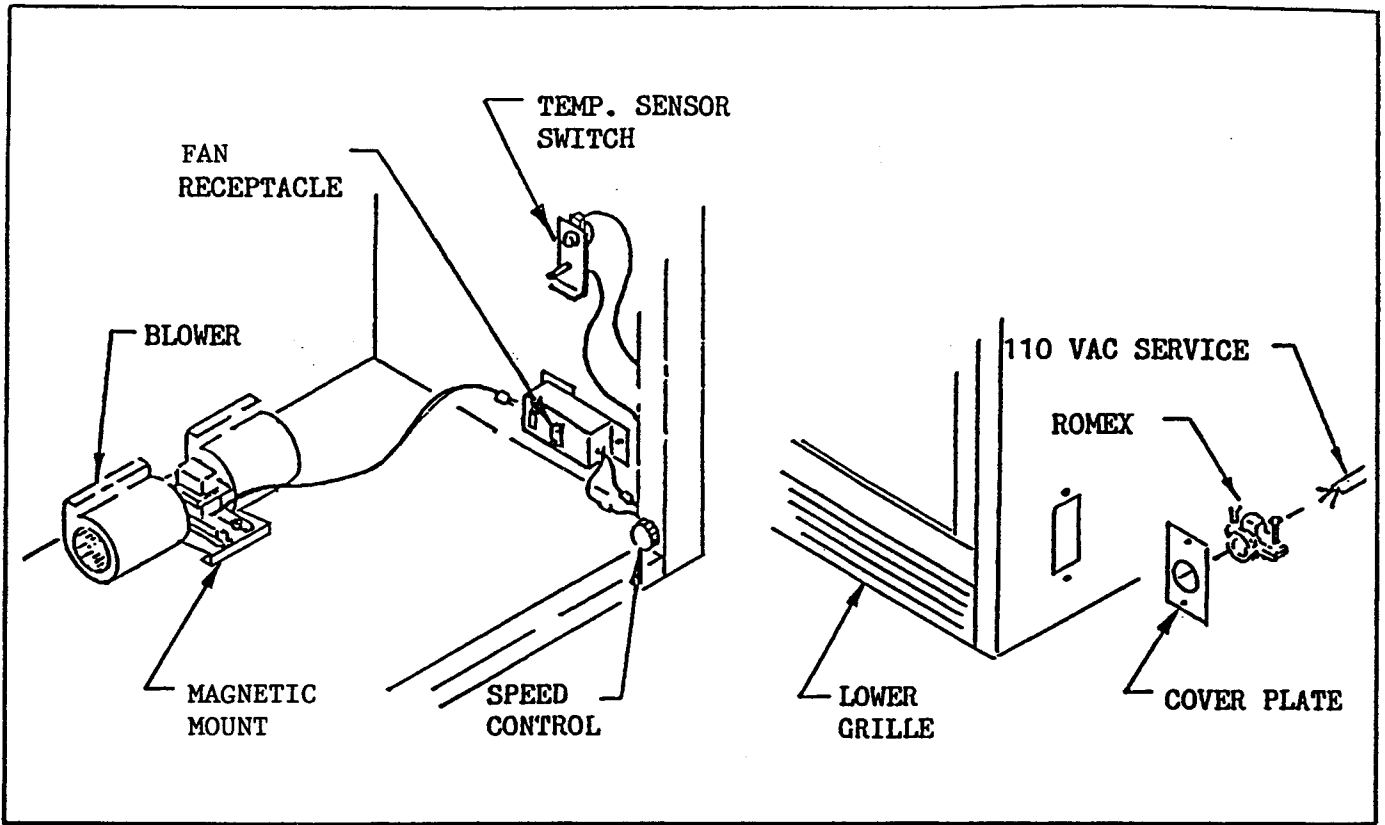

FIGURE 15

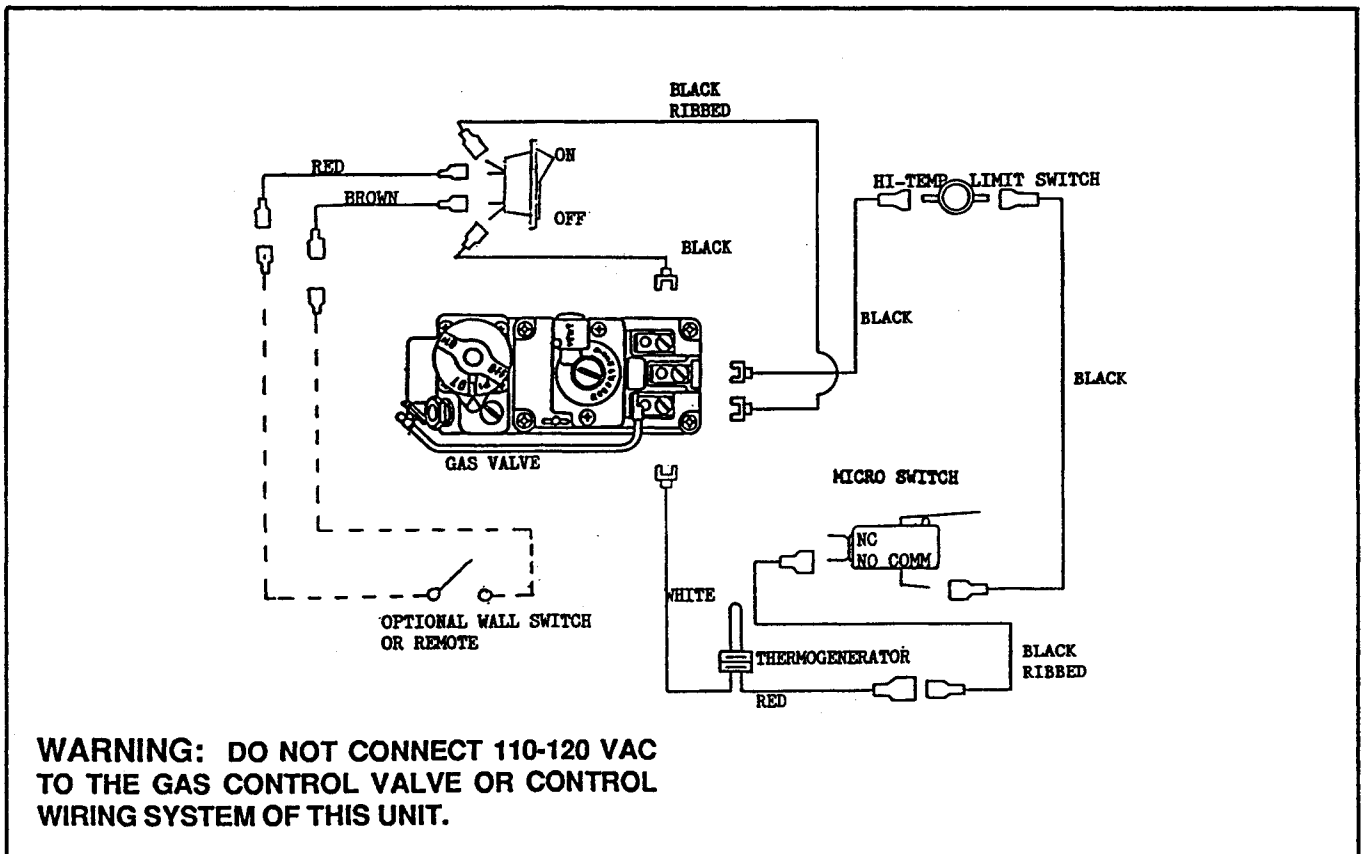

FIGURE 16

3.9 WALL SWITCH WIRING

An Optional Wall Switch Kit (WSK-21) for turning the fireplace ON/OFF is also available. This kit does NOT require 110 VAC. Connect the low voltage wires from the wall switch to the red and brown pigtail wires from the ON/OFF rocker switch. These wires are labeled "FOR REMOTE OR WALL SWITCH ONLY". Turn the unit's ON/OFF rocker switch to the "OFF" position to use the wall switch. See Figure 16 - Unit Wiring Diagram.

NOTE: POSITION THE WALL SWITCH SO THAT A MAXIMUM OF 25 FEET OF WIRING FROM THE SWITCH TO THE FIREPLACE IS USED.

WARNING: DO NOT CONNECT 110- 120 VAC TO THE GAS CONTROL VALVE OR CONTROL WIRING SYSTEM OF THIS UNIT.

3.10 FINISHING

Finish the walls with the material of your choice. Do not install a combustible mantle or other combustible projection above the fireplace opening unless it is a minimum of 12 inches above the front edge of the hood (Figure 17).

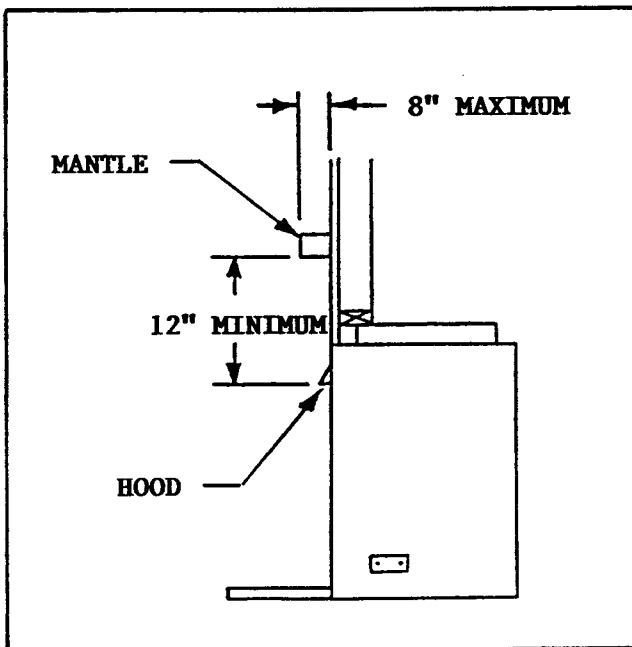

FIGURE 17

When finishing the fireplace NEVER OBSTRUCT OR MODIFY THE AIR INLET/OUTLET GRILLES IN ANY MANNER.

CAUTION: ALL JOINTS BETWEEN THE FINISHED WALL AND THE FIREPLACE SURROUND (TOP AND SIDES) CAN ONLY BE SEALED WITH NON-COMBUSTIBLE MATERIAL. ONLY NON-COMBUSTIBLE MATERIAL CAN BE APPLIED AS FACING TO THE FIREPLACE SURROUND. SEE FIGURE 18.

DO NOT put any finishing material on the Vent Cap. DO NOT extend a combustible overhang more than 1- 1/2 inches beyond the exterior wall itself, unless the overhang is at least 18 inches above the cap (See Figure 11).

3.11 HEARTH EXTENSION

While a hearth extension may be desirable for aesthetic reasons, it is not required for decorative gas appliances per ANSI or CAN/CGA testing standards.

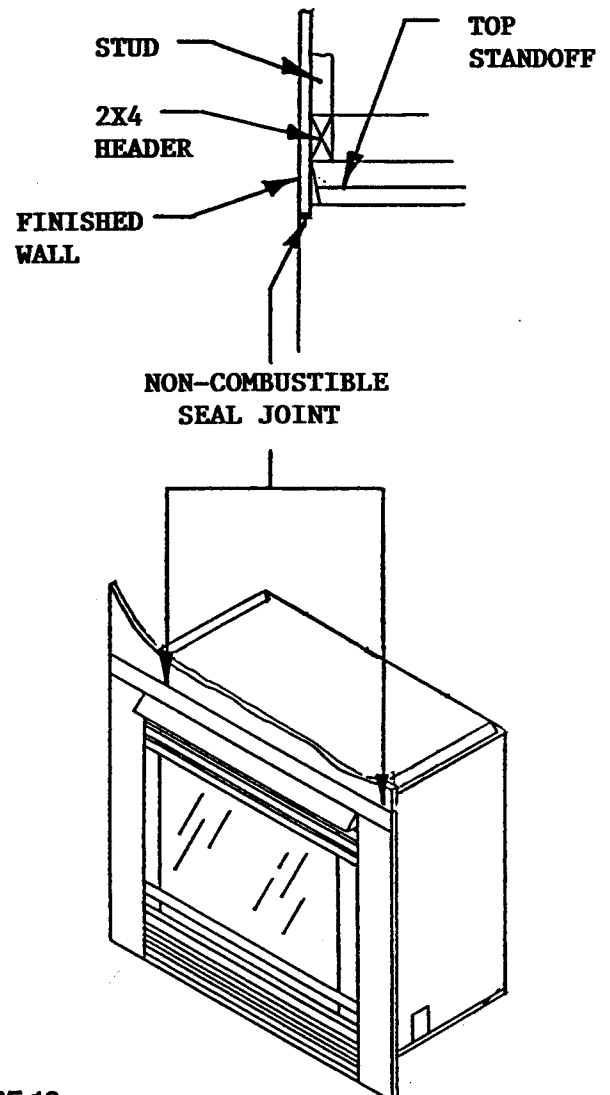

FIGURE 18

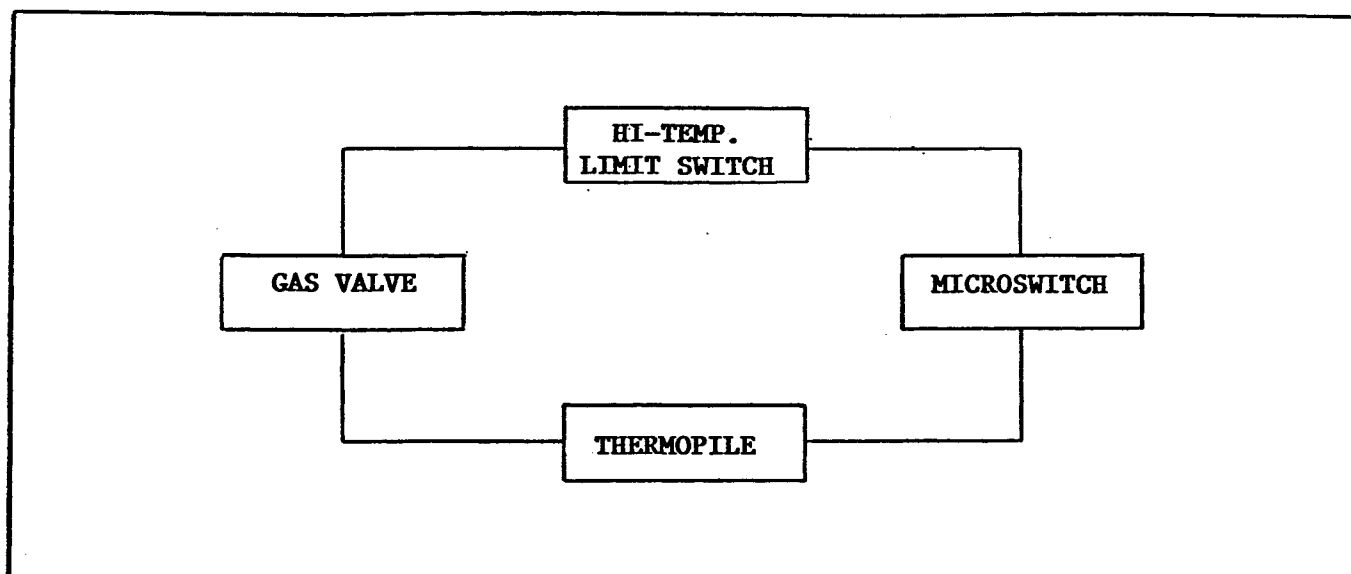

FIGURE 19

4.0 ELECTRICAL SAFETY SYSTEM

WARNING: DO NOT CONNECT 110-120 VAC TO THE GAS CONTROL VALVE OR CONTROL WIRING SYSTEM OF THIS UNIT.

The 5000GDV system is wired so the thermogenerator, when heated with the pilot light, will provide approximately 350 to 500 millivolts. This activates the gas control valve. For protection, the glass door must be installed and sealed to work (this activates the micro switch).

Additionally, a high temperature limit switch is used for protection and will close the main gas valve should a high surface temperature condition be encountered (Figure 19).

5.0 OPERATING GUIDELINES MAINTENANCE INSTRUCTIONS

Upon completing the gas line connection, a small amount of air will be in the lines. When first lighting the pilot light, it will take a few minutes for the lines to purge themselves of this air. Once the purging is complete, the pilot and burner will light and operate as indicated in the Instruction Manual.

Subsequent lightings of the appliance will not require such purging.

CAUTION: DURING THE INITIAL PURGING AND SUBSEQUENT LIGHTING'S NEVER ALLOW THE GAS VALVE CONTROL KNOB TO REMAIN DEPRESSED IN THE "PILOT" POSITION WITHOUT PUSHING THE RED IGNITOR BUTTON AT LEAST ONCE EVERY SECOND.

When lit for the first time, the appliance will emit a slight odor for an hour or two. This is due to paint and lubricants used in the manufacturing process. Additionally, for the first few minutes after each lighting, vapor may condense and fog the glass and the flames may be blue. After a few minutes this moisture will disappear and within 15-30 minutes the flames should become yellow.

Keep the control compartment, logs, and burner area surrounding the logs clean by vacuuming or brushing at least twice a year.

CAUTION: THE LOGS CAN GET VERY HOT - HANDLE ONLY WHEN COOL.

Always turn off gas to the pilot before cleaning. For relighting, refer to lighting instructions located behind the lower front trim assembly.

The appliance and venting system should be inspected before initial use and at least annually by a qualified field service person.

Always keep the appliance area clear and free from combustible materials, gasoline, and other flammable vapors and liquids.

Never obstruct the flow of combustion and ventilation air. Keep the front of the appliance clear of all obstacles and materials.

To obtain proper operation, it is imperative that the pilot and main burner flame characteristics are steady, not lifting or floating. Typically, the top 3/4-inch at the pilot generator should be engulfed in the pilot flame (Figure 20).

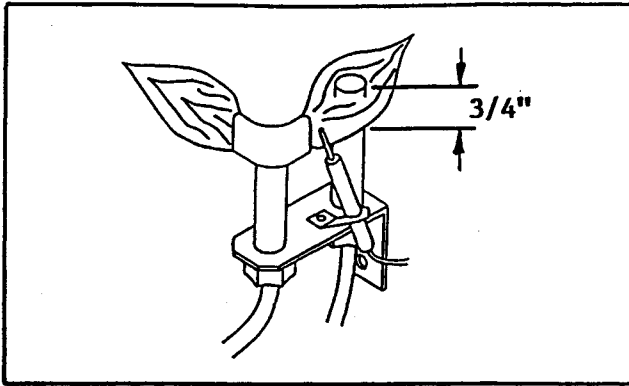

FIGURE 20

WARNING: CHILDREN AND ADULTS SHOULD BE ALERTED TO THE HAZARDS OF HIGH SURFACE TEMPERATURE AND SHOULD STAY AWAY TO AVOID BURNS OR CLOTHING IGNITION. YOUNG CHILDREN SHOULD BE CAREFULLY SUPERVISED WHEN THEY ARE IN THE SAME ROOM AS THE APPLIANCE.

IMPORTANT: TURN OFF GAS BEFORE SERVICING APPLIANCE. IT IS RECOMMENDED THAT A COMPETENT SERVICE TECHNICIAN PERFORM THESE CHECK-UPS AT THE BEGINNING OF EACH HEATING SEASON.

WARNING: DO NOT USE ABRASIVE CLEANERS ON THE GLASS DOOR ASSEMBLY. DO NOT ATTEMPT TO CLEAN THE GLASS DOOR WHEN IT IS HOT.

Inspect the external vent cap on a regular basis to make sure that no debris is interfering with the air flow.

5.1 GLASS DOOR REMOVAL

1. To remove the glass door, you must remove the mesh trim front panel by lifting it up off the retainer pins on the side surrounds and pulling it away from the unit.
2. Noting carefully how the brackets fit on the glass, remove wing nuts and brackets from the glass door.
3. The glass door is now ready for removal.

5.2 CLEANING BURNER AND PILOT

In order to properly clean the burner and pilot assembly, turn off the gas to the unit and remove the logs exposing the burner and pilot assembly.

Clean all foreign materials from top of burner. Check to make sure that the burner orifice is clean.

Visually inspect the pilot periodically. Brush or blow away any dust or linen accumulations. If the pilot orifice is plugged, disassembly may be required to remove any foreign material from the orifice or tubing. When the appliance is put back in service check burner flame patterns with Figure 21.

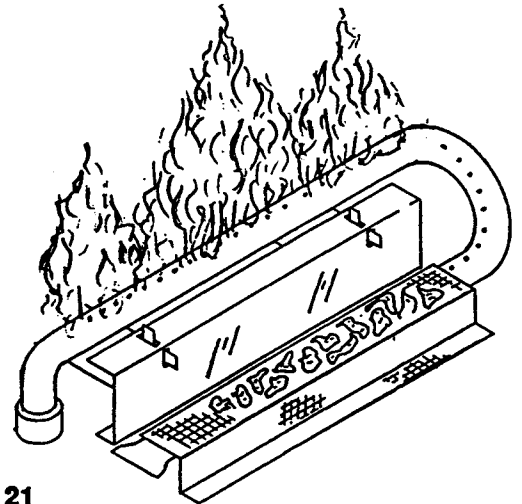

FIGURE 21

5.3 LOG REPLACEMENT

1. Remove the mesh trim and glass door assemblies (See Section 5.1).
2. The Log(s) can now be removed as required. Replace the log(s) as previously shown in Figure 2 - Gas Log Positioning. Replace glass door and mesh trim.

5.4 GLASS DOOR REPLACEMENT

1. Before replacing the glass door make sure the vermiculite material is spread evenly over the bottom of the firebox and the logs are properly positioned.
2. Place the bottom edges of the glass door on the rubber spacers of the bottom mounting studs on the fireplace. Be certain that the top corner of the door pushes against the MICROSWITCH paddle.

NOTE: IF THE GLASS DOOR DOES NOT PUSH AGAINST THE MICROSWITCH, THE PILOT WILL NOT STAY ON.

3. With glass door in place push glass against unit and at the same time put brackets on upper portion of door and tighten the wing nuts provided.
4. Attach the brackets at the sides and bottom of the glass and hand tighten.

NOTE: WING NUTS THAT SECURE THE GLASS ONLY NEED TO BE HAND TIGHTENED TO GIVE A SNUG FIT FOR PROPER GASKET SEAL. OVER-TIGHTENING MAY RESULT IN DAMAGED GLASS.

WARNING: THE GLASS DOOR ASSEMBLY MUST BE IN PLACE AND SEALED AND THE FIXED MESH TRIM ASSEMBLY MUST BE IN PLACE ON THE FIREPLACE BEFORE THE UNIT CAN BE PLACED INTO SAFE OPERATION.

5. Replace the mesh trim front proceeding in reverse order of step 1 under Glass Door Removal.

6.0 SAFETY INFORMATION

FOR YOUR SAFETY READ BEFORE LIGHTING

WARNING: IF YOU DO NOT FOLLOW THESE INSTRUCTIONS EXACTLY, A FIRE OR EXPLOSION MAY RESULT CAUSING PROPERTY DAMAGE, PERSONAL INJURY, OR LOSS OF LIFE.

A. This appliance has a pilot. When lighting the pilot, follow these instructions exactly.

B. BEFORE LIGHTING smell all around the appliance area for gas. Be sure to smell next to the floor because some gas is heavier than air and will settle on the floor.

WHAT TO DO IF YOU SMELL GAS

- Do not try to light any appliance
- Do not touch any electric switch: do not use any phone in your building.
- Immediately call your gas supplier from a neighbor's phone. Follow the gas supplier's instructions.
- If you cannot reach your gas supplier, call the fire department.

C. Use only your hand to push in or turn the gas control knob. Never use tools. If the knob will not push in or turn by hand, don't try to repair it. Call a qualified service technician. Forced or attempted repair may result in a fire or explosion.

D. Do not use this appliance if any part has been under water. Immediately call a qualified service technician to inspect the appliance and to replace any part of the gas control system which has been under water.

7.0 LIGHTING INSTRUCTIONS

LIGHTING INSTRUCTIONS

1. "STOP!" Read the safety information above first.

2. To access controls rotate up the bottom hinged grille.

3. Turn the valve control knob to the OFF position. To do this, you must turn the knob clockwise to the pilot position, and then press in and continue turning clockwise to the OFF position.

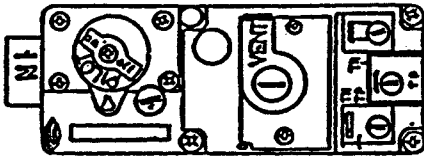

GAS CONTROL VALVE

4. WAIT FIVE (5) MINUTES TO CLEAR OUT ANY GAS. If you then smell gas, STOP! Follow "B" in the safety information above. If you don't smell gas, go to the next step.

5. The pilot should not require accessing for lighting purposes. The pilot is located inside the combustion chamber. If it is necessary to access the pilot, follow the instructions in Section 5.1 for glass door removal.

THERMOPILE

PILOT BURNER



6. To put the control in the pilot position, turn the control knob counter-clockwise to the pilot position.

7. To light the pilot depress the control knob and then depress the red piezo button until it makes a clicking sound. It may be necessary to repeat this step. If the pilot does not light after 10 seconds, go back to step 3. The control knob should be held down for a MINUTE after pilot ignition. If the pilot will not stay lit after two tries, turn the control knob to the "OFF" position and call your service technician or gas supplier. If the control knob does not pop out when released, STOP-shut off the gas supply to the fireplace control valve, and IMMEDIATELY call your service technician or gas supplier.

8. After the pilot has been lit, the burner can be turned on by turning the knob counter-clockwise to the "ON" position. Flip the ON/OFF switch to the "ON" position.

9. Close the bottom grille.

TO TURN OFF GAS TO APPLIANCE

1. Open the bottom grille.

2. Turn ON/OFF switch to "OFF".

3. Turn the valve control knob clockwise to the "Pilot" position then depress knob and continue turning to "OFF" position.

4. Close the bottom grille.

After the unit has warmed up (i.e. approx. 15 min.), flame height should be slightly (about 2") below the top of the mesh trim assembly (Figure 22). If the flame height is higher than this, adjustments must be made to prevent overheating the gasket and glass. Please contact your dealer or a qualified service-person to replace the orifice or adjust the valve.

NOTE: THE TIPS OF THE FLAMES SHOULD NEVER HIT THE TOP OF THE FIREBOX.

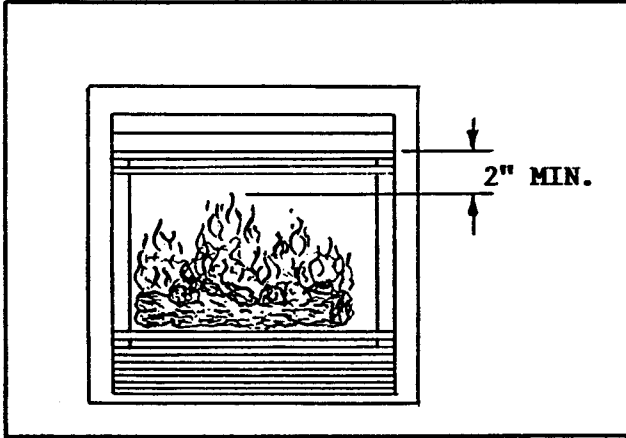

FIGURE 22

LPG (PROPANE) WARNING

THE FOLLOWING WARNING APPLIES TO INSTALLATIONS USING L.P. (PROPANE) GAS:

WARNING: To avoid possible injury, fire and explosion, please read and follow these precautions and all instructions on this appliance before lighting the pilot. This appliance uses L.P. (Propane) gas which is heavier than air and will remain at floor level if there is a leak. Before lighting, smell at floor level and/or use other means (such as using a soap solution on all piping and connections, using a gas detector, etc.) to check for gas leaks. **NOTE:** L.P. (Propane) gas can become odorless and **CANNOT** always be detected by smell. If you smell gas, detect a gas leak, or suspect that a gas leak exists, follow these rules.

1. Get all people out of building.
2. DO NOT light matches. DO NOT turn electric lights or switches on or off in area. DO NOT use an electric fan to remove gas from area. DO NOT use a telephone inside the building.
3. Shut off gas at L.P. tank outside of building.
4. Telephone gas company and fire department. Ask instructions.

Before hanging up, give your name, address, and phone number. **DO NOT** go back into building.

If your L.P. tank runs out of fuel, turn off gas at the appliance. After L.P. tank is refilled, appliance must be re-lit according to manufacturer's instructions. If the gas control has been exposed to **WATER** in any way, **DO NOT** try to use it. It must be replaced. **DO NOT** attempt repair on gas control or appliance.

Tampering is **DANGEROUS** and voids all warranties. Any component that is found to be faulty, must be replaced with an approved component.

8.0 HIGH ALTITUDE INSTALLATION

A.G.A. Design Certified units are tested and approved for elevations from 0-2000 feet. CGA approved units are certified for elevations from 0-4500.

When installing this unit at an elevation above 2000 feet, (in United States) it may be necessary to decrease the input rating by changing the existing burner orifice to a smaller size. Input should be reduced 4 percent for each 1000 feet above sea level. Check with your local gas company for help in determining the proper orifice size.

When installing this unit at an elevation between 0-4500 feet (in Canada) the input rating does not need to be reduced.

When installing this unit at an elevation above 4500 feet (in Canada), check with local authorities.

Consult your local gas company for assistance in determining the proper orifice for location.

9.0 TROUBLE SHOOTING - 5000GDV

With proper installation and maintenance, your new Gas Fireplace should provide years of trouble-free service. If you do experience a problem, refer to the trouble shooting guide shown below. This guide will assist a qualified service person in the diagnosis of problems and the corrective action to be taken.

SYMPTOM	POSSIBLE CAUSE	CORRECTIVE ACTION
I. Spark Ignitor will not light pilot after repeated triggering of red button.	A. Defective ignitor (no spark at electrode.)	1. Check for spark at electrode and pilot; if no spark and electrode wire is properly connected, replace ignitor.
	B. Defective pilot or misaligned electrode (spark at electrode).	1. Using a match, light pilot. If pilot lights, turn off pilot and trigger the red button again. If pilot lights, an improper gas/air mixture caused the bad lighting and a longer purge period is recommended. If pilot will not light - check gap at electrode and pilot - should be 1/8 inch to have a strong spark. If OK, replace pilot.
	C. No gas or low gas pressure.	1. Check remote shut off valves from fireplace. Usually there is a valve near the main. There can be more than one (1) valve between the fireplace and main. 2. Low pressure can be caused by a variety of situations such as a bent line, too narrow diameter of pipe or even low line pressure. Check for kinked lines. If none, consult with plumber or gas supplier.
	D. No L.P. in tank.	3. Check L.P. (Propane) tank. You may be out of fuel.
II. Pilot will not stay lit after carefully following lighting instructions.	A. Defective thermogenerator.	1. Check pilot flame. Must impinge on thermogenerator. Clean and or adjust pilot for maximum flame impingement on generator. 2. Be sure wire connections from generator at gas valve terminals are tight and generator is fully inserted into pilot bracket.

SYMPTOM	POSSIBLE CAUSE	CORRECTIVE ACTION
<p>III. Pilot burning, no gas burner, valve knob "ON", "on/off" switch "ON".</p>	<p>A. "On-off" switch or wires defective.</p>	<p>3. Check thermogenerator with millivolt meter. Take reading at "TH-TP & TP" terminals of gas valve. Should read 325 millivolts minimum while holding valve knob depressed in pilot position, pilot lit, and "on/off" switch "OFF". Replace faulty generator if reading is below specified minimum.</p> <p>1. Disconnect the thermo-generator's red wire from the micro-switch and connect to terminal "TP" on the gas valve. Turn green knob to pilot position, depress and light pilot light. If meter reading is greater than 325 m.v. after 30 seconds, the pilot generator is good. If pilot does not stay lit, the valve is defective. If the meter reading is less than 325 m.v., the thermo-generator is defective.</p> <p>1. Adjust glass so it fully depresses the microswitch. (Do not operate the unit with broken or cracked glass).</p> <p>2. If fully depressed, place jumper wires across connectors and if it allows you to re-ignite, the switch should be replaced. Do not operate unit with jumper wires in place. When jumper wires are in place and the unit won't re-ignite, you may have problems with the wiring or connectors.</p> <p>1. Check wire continuity and connection in pilot circuit.</p> <p>1. Check "on-off" switch and wires for proper connections. Place jumper wires across terminals at switch - if burner comes on, replace defective switch. If OK, place jumper wires across switch wires at gas valve - if burner comes on, wires are faulty or connections are bad.</p>
	<p>B. Defective valve.</p>	
	<p>C. Glass door does not fully depress Microswitch.</p>	
	<p>D. Open wire connection in pilot circuit.</p>	

SYMPTOM	POSSIBLE CAUSE	CORRECTIVE ACTION
	B. Thermogenerator may not be generating sufficient millivoltage. (325 m.v.)	1. Recheck Symptom #2. 2. Pilot flame not physically close enough to the thermogenerator.
	C. Defective valve.	1. Turn valve knob to "ON" place "on-off" switch to "ON". Check with millivolt meter at generator terminals. Millivolt meter should read greater than 100 m.v. If the reading is okay and the burner does not come on, replace the gas valve.
	D. Plugged burner orifice.	1. Check burner orifice for stoppage and remove.
	E. Wall switch or wires defective.	1. Follow corrective action in A.1 above; check switch and wiring. Replace where defective.
IV. Frequent pilot outage problem.	A. Pilot flame may be too low or blowing (high), causing the pilot safety to drop out.	1. Clean and adjust pilot flame for maximum flame impingement on thermogenerator.
V. Pilot and main burner go out while being in operation.	A. High limit switch is defective or has reached its maximum temperature.	1. Allow unit to cool. Then repeat lighting instructions. 2. If 1 above does not allow for ignition, check high limit switch. Place jumper wires across high limit switch. If you can re-ignite the pilot, your high limit switch is defective. Do not use fireplace until high limit switch is replaced as this is an important safety feature. If the unit does not light with jumper wires in place, the wires may be defective or the connectors are bad.
	B. Door microswitch is not fully depressed or defective.	1. Adjust glass so it fully depresses the microswitch. (Do not operate unit with broken or cracked glass). 2. If fully depressed, place jumper wires across connectors and if it allows you to re-ignite, the switch should be replaced. Do not operate unit with jumper wires in place. When jumper wire is in place and the unit won't re-ignite, you may have problems with the wiring or connectors.

SYMPTOM	POSSIBLE CAUSE	CORRECTIVE ACTION
	C. No L.P. in tank.	1. Check L.P. (Propane) tank. You may be out of fuel.
	D. Inner 5-inch pipe leaking exhaust gases back into system.	1. Check for leaks.
	E. Horizontal vent improperly pitched.	1. Horizontal vent should slope down only enough to prevent any water from entering unit. The maximum downward slope is 1/4" for any horizontal run.
	F. Glass too loose and air tight gasket leaks in corners after usage.	1. Tighten corner.
	G. Bad thermogenerator.	1. Replace if necessary.
	H. Improper vent cap installation.	1. Check for proper installation & freedom from debris or blockage.
VI. Glass soots	A. Flame impingement on logs.	1. Adjust the log set so that the flame does not impinge on it.
	B. Improper venturi setting.	1. Adjust the air shutter at the base of the burner.
	C. Vermiculite around venturi.	1. Inspect the opening in the vermiculite dam at the base of the burner. It is imperative that NO material be placed in this opening.
VII. Flame burns blue and lifts off burner.	A. Insufficient oxygen being supplied.	<p>1. Check to make sure vent cap is installed properly and free of debris. Make sure that vent system joints are tight and have no leaks.</p> <p>2. Check to make sure that the vermiculite has not been improperly placed in the vermiculite dam down at the burner base.</p> <p>3. Be sure glass is tightened properly on unit, particularly on top corners.</p>

LIMITED WARRANTY POLICY FOR GAS TECHNOLOGIES, INC. GAS FIREPLACES

The limited two year warranty will not become effective until the completed warranty card has been mailed to GAS TECHNOLOGIES, INC., Savage, MN 55378.

This card must be mailed within 60 days of the fireplace installation.

Subject to the conditions set forth herein, Gas Technologies, Inc. extends the following limited warranty with respect to Gas Technologies, Inc. Decorative Gas Fireplaces.

If Gas Technologies, Inc. is satisfied that any part or portion of the fireplaces covered by this warranty is defective in material or workmanship under normal use and service as described in the operating instructions, Gas Technologies, Inc. will take the following actions:

1. Within the first year from the date of installation, Gas Technologies, Inc. shall, at its option, replace or repair any such defect in material or workmanship, at Gas Technologies, Inc. expense. GAS TECHNOLOGIES, INC. SHALL NOT BE RESPONSIBLE FOR ANY OTHER LABOR COSTS, OR EXPENSES, INCLUDING INDIRECT, INCIDENTAL OR CONSEQUENTIAL DAMAGES.
2. During the second year after the date of installation, GAS TECHNOLOGIES, INC. shall supply replacement parts at the current minimum wholesale price, but GAS TECHNOLOGIES, INC. SHALL NOT BE RESPONSIBLE FOR ANY LABOR, TRANSPORTATION, OR OTHER INDIRECT, INCIDENTAL, OR CONSEQUENTIAL DAMAGES.
3. During the first six months after installation, GAS TECHNOLOGIES, INC. shall, at its option, replace or repair the glass door if operation is faulty (this does not include glass panels broken during shipping, misuse or careless handling). GAS TECHNOLOGIES, INC. SHALL NOT BE RESPONSIBLE FOR ANY LABOR, TRANSPORTATION OR OTHER INDIRECT, INCIDENTAL, OR CONSEQUENTIAL DAMAGES. IF GLASS DOORS OTHER THAN FACTORY DOORS ARE USED, ALL WARRANTY AND LIABILITY ON THE FIREPLACE IS VOIDED.
4. All electrical, manual, and optional components or accessories found to be defective will be repaired or replaced without charge during the first year after installation.

Gas Technologies, Inc. may discharge its entire warranty liability by refunding the price of the product.

Products made by other manufacturers, sold with the fireplace or thereafter are not covered by this limited warranty. The use of other unauthorized components will make this warranty null and void.

This limited warranty will be void if the appliance is not installed by a qualified installer and according to the installation instructions. The limited warranty also is void if the fireplace is not operated, at all times, according to the operating instructions furnished.

EXCEPT TO THE EXTENT PROVIDED BY LAW, NO IMPLIED WARRANTIES OR MERCHANTABILITY OR FITNESS FOR A PARTICULAR PURPOSE, AND NO IMPLIED WARRANTIES SHALL APPLY TO THE FIREPLACE AFTER THE ABOVE LIMITED WARRANTY HAS EXPIRED.

In states that do not allow limitations on how long implied warranty lasts, or do not allow exclusion of indirect damages, those limitations or exclusions may not apply to you. You may also have additional rights not covered in this limited warranty.

Gas Technologies, Inc. reserves the right to make changes at anytime, without notice, in design, material, specifications and prices and the right to discontinue styles and products.

FOR MODEL 5000GDV-HSI ADDENDUM FOR ELECTRONIC IGNITION SYSTEM

This unit requires 110VAC service in order to operate. Connection to house wiring should ONLY be done by a Qualified Electrician.

FOR YOUR SAFETY READ BEFORE OPERATING HSI CONTROLS

WARNING: If you do not follow these instructions exactly, a fire or explosion may result causing property damage, personal injury or loss life.

A. This appliance does not have a pilot. It is equipped with an ignition device which automatically lights the burner. Do not try to light the burner by hand.

B. BEFORE Operating smell all around the appliance area for gas. Be sure to smell next to the floor because some gas is heavier than air and will settle on the floor.

WHAT TO DO IF YOU SMELL GAS

- * Do not try to light any appliance.
- * Do not touch any electric switch, do not use any phone in your building.
- * Immediately call your gas supplier from a neighbor's phone. Follow the gas supplier's instructions.
- * If you cannot reach your gas supplier, call the fire department.



C. Use only your hand to turn the gas control knob. Never use tools. If the knob will not turn by hand, don't try to repair it, call a qualified service technician. Force or attempted repair may result in a fire or explosion.

D. Do not use this appliance if any part has been under water. Immediately call a qualified service technician to inspect the appliance and to replace any part of the control system and any gas control which has been under water.

LIGHTING INSTRUCTIONS 5000GDV-HSI CONTROLS

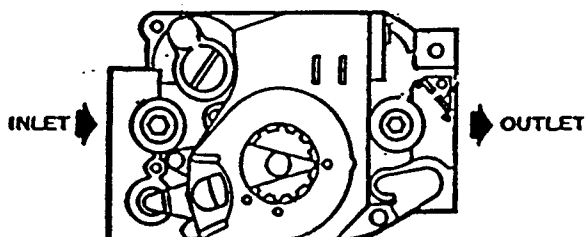
1. **STOP!** Read the safety information on the "For Your Safety Read Before Operating" label.
2. Turn off all electric power to the appliance.
3. This appliance is equipped with an ignition device which automatically lights the burner. Do not try to light the burner by hand.



4. Turn gas control knob clockwise  to "OFF".
5. Wait five (5) minutes to clear out any gas. If you then smell gas, **STOP!** Follow "B" in the safety information on the label located on the previous page. If you don't smell gas, go to next step.
6. Turn on all electric power to the appliance.
7. Turn gas control knob counter-clockwise  to "ON".
8. Flip ON/OFF rocker switch to "ON" and close access grille.
9. If the appliance will not operate, follow the instructions "To Turn Off Gas To Appliance" and call service technician or gas supplier.

TO TURN OFF GAS TO APPLIANCE

1. Flip ON/OFF switch to "OFF".
2. Turn off all electric power to the appliance if service is to be performed.
3. Turn gas control knob clockwise  to "OFF". Do not force.

OPTIONAL SWITCH WIRING MODEL 5000GDV-HSI

An Optional Wall Switch (WSK-21) or Remote Control Switch (RCH-09A) may be wired to this appliance. The Wall Switch **DOES NOT** require 110-120 VAC electrical service connection. The remote control receiver **DOES** require 110-120 VAC which is obtained at the pre-installed junction box. Connect low voltage wires from the optional switch installed to the black wires (labeled Optional Wall Switch or Remote) found behind the lower grille. Set the unit's ON/OFF rocker switch to the "ON" position. Activate the optional switch installed to control the main burner of the unit. Detailed installation instructions for optional switches are found in each accessory kit.

NOTE: When using an optional switch in Model 5000GDV-HSI, a humming sound from the control system transformer may be audible when the burner is turned off. This sound will stop if the ON/OFF rocker switch is turned to "OFF".

WARNING: DO NOT CONNECT 110-120 VAC TO AN OPTIONAL WALL SWITCH INSTALLED TO THIS FIREPLACE.

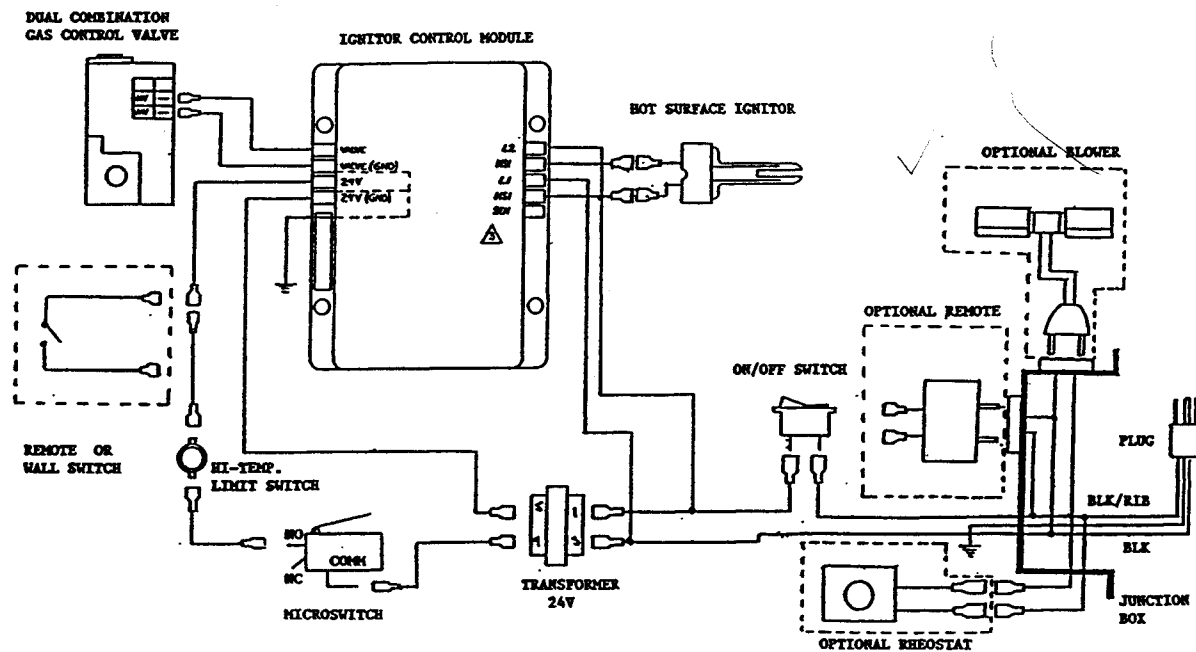

From: Ross Morrison
To:
Sales Group, Sales HNG_Field,
Sales Independent_Reps
Subject:
Fwd: 5000GDV'S WITH THE SIT
VALVE

===NOTE=====9/17/96==4:40pm==
THE UNITS STARTED SHIPPING THIS WAY IN
APRIL OF '96. THE STARTING SERIAL
NUMBERS FOR THESE UNITS:

NG 22932
LP 4683

CONVERSION KITS FOR THE NEW UNITS ARE:

LPK-5DV-SIT
NGK-5DV-SIT

Fwd-by:=Chad=Hendrick=11/06/97==2:37pm=
Fwd to: Robert Nickerson
.....

ELECTRICAL CONNECTIONS

General precautions

All electrical connections must be made in accordance with current electrical standards. Check that the voltage and frequency of the coils, given on the valve, are correct. Check that all connections are made properly.

24V OPERATOR	
Voltage (AC)	Consumption (mA)
24V 60Hz	220

MILLIVOLT OPERATOR	
Use millivoltage generator with two leads	
Open circuit voltage	≥ 325mV
Closed circuit voltage	≥ 100mV
Operator resistance	1.6Ω

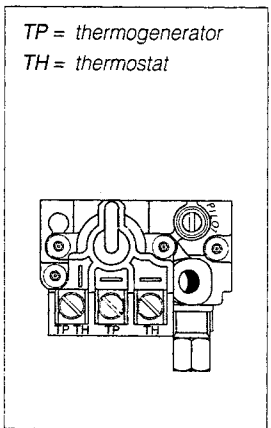
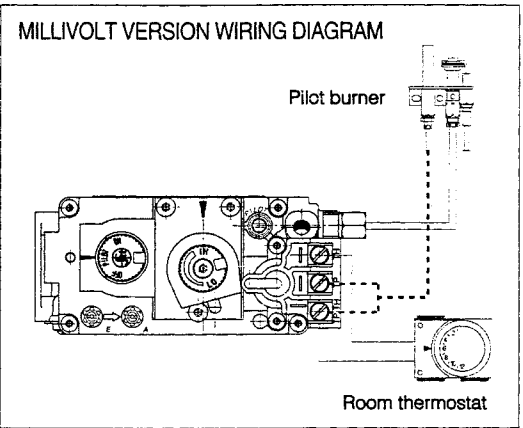
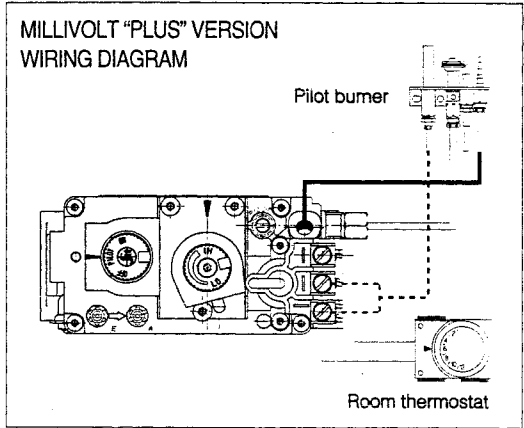
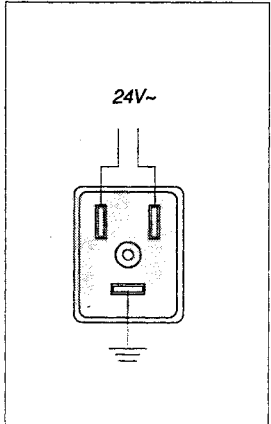
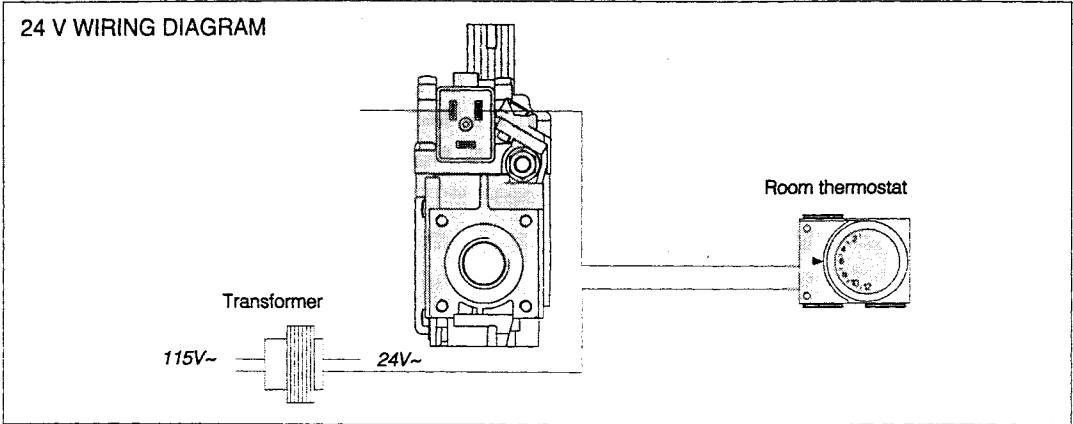

VALVE DESCRIPTION

- ① Gas cock knob
- ② Manual HI-LO adjustment or pressure regulator adjustment
- ③ Pilot adjustment
- ④ Termocouple connection
- ⑤ Mounting for piezo & bracket
- ⑥ Inlet pressure test point
- ⑦ Outlet pressure test point
- ⑧ Main operator
- ⑨ Pilot outlet
- ⑩ Main gas outlet
- ⑪ Flange securing screw holes
- ⑫ Additional valve mounting hole
- ⑬ Alternative TC connection point
- ⑭ Thermoelectric unit

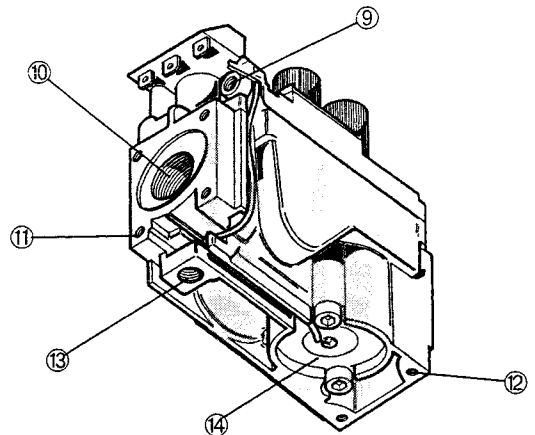
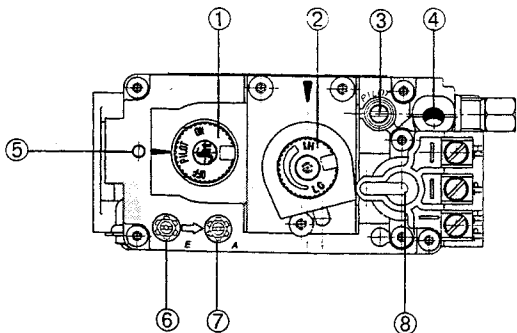

PRODUCT INFORMATION

32" DIRECT VENT MODEL 5000GDV

STANDARD FEATURES

- 21,000 BTU Input/hr.
- High Efficiency (up to 70%+)*
- Sealed Combustion Chamber (Air Tight System)
- Fixed Mesh Safety Screen
- Six Realistic Looking Oak Logs
- Large Glass Door Area (24-3/4" x 15-7/8")
- Safety: High Temperature Limit Switch and Glass Microswitch
- Piezo Ignitor and Safety Pilot
- Burning Embers and Yellow Flames
- Installed Junction Box for Blower and/or Remote Control
- Clean Burning Inside and Outside
- Polished Brass Trim

MODEL

Model	Product	Suggested Retail
5000GDV	Direct Vent Unit	\$1099
5000GDV-HSI	Direct Vent Unit with Hot Surface Ignitor	1249
5000GDV-MH	Direct Vent Mobile Home	1149

APPROVALS

- A.G.A. Design Certified for Natural or Propane Gas
- CGA Certified
- Mobile Home Approved
- Vertical and Horizontal Termination Approved
- Approved with Hot Surface Ignitor

OPTIONS

RCH-09A	Remote Control	\$150
RC-STAT	Remote Thermostat	199
WSK-21	Wall Switch Kit	16
WSK-21-W	White Wall Switch Kit	18
GFK-160A	Fan Kit 160CFM**	179
FILTERS-2	Air-Supreme Filter for GFK-160A(2)	35
DRC-DV	Decorative Rectangular Cover	26
VPK-DV	Vinyl Protector Kit	26
Special Order		
DF-5000DV	Mesh Front***	65

*As tested by Gas Technologies with horizontal termination.

**Includes on/off temperature sensor switch for blower and variable speed control.

***May be custom ordered in these finishes: SB=Satin Brass, AB=Antique Brass, PC=Polished Chrome, BK=Black.

EX: DF-5000DV-AB for Antique Brass.

All standard with fixed screen.

All prices are in U.S. dollars.

VENT KITS*

DVK-01D	Horizontal Termination Kit Round 5"-7"	\$104
DVK-01SD	Horizontal Termination Kit Square 5"-7"	129
DVK-01TRD	Trapezoid Termination Kit 5"-7"	109
DVK-02D	Horizontal Termination Kit Round 11"-13"	140
DVK-02SD	Horizontal Termination Kit Square 11"-13"	155
DVK-02TRD	Trapezoid Termination Kit 11"-13"	145
DVK-TVCD	Vertical Termination Kit	78
DVK-SNKD	Snorkel Cap	239
DV-06D	6" Pipe Length	24
DV-09D	9" Pipe Length	27
DV-12D	12" Pipe Length	30
DV17-24D	17 x 24 Adjustable Pipe	60
DV-36D	36" Pipe Length	45
DV-48D	48" Pipe Length	60
DV-45D	45 Degree Elbow	45
DV-90D	90 Degree Elbow	49

*Not included with the unit.

S P E C I F I C A T I O N S

Model	Height		Front Width		Back Width		Depth		Front Glass Door	BTU Input
	Actual	Framing	Actual	Framing	Actual	Framing	Actual	Framing		
5000 GDV	29"	30"	36"	37"	35"	37"	18"	19"	24 1/2" x 15 7/8"	21,000

NOTE: MANTLE MUST BE A MINIMUM OF 12" ABOVE THE TOP OF DOOR OPENING.
NOTE: GAS FIREPLACES DO NOT REQUIRE A HEARTH.

