

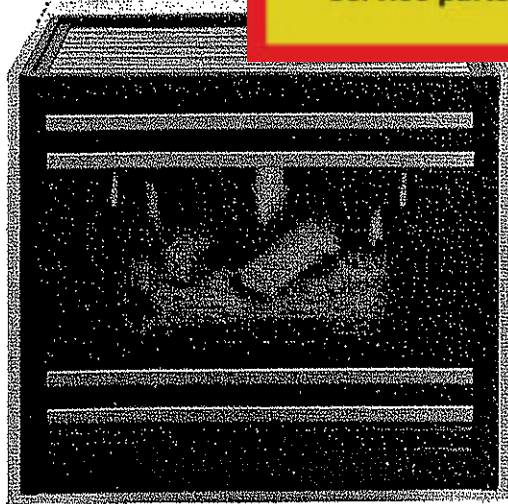

This appliance has been retired.
Service parts pages within have been removed.
For replacement parts, please refer to the individual
service parts list located on the brand websites.



U.S. PATENT 4,793,322 AND PATENTS PENDING

Model 4000 WH Installation and Operation Instructions

A.G.A. Design Certified
CGA Certified



THIS MANUAL MUST BE USED FOR INSTALLATION AND RETAINED BY THE HOMEOWNER FOR
OPERATION AND MAINTENANCE.

GAS TECHNOLOGIES, INC.
6665 W. Hwy. 13 Savage, MN 55378 (612)890-8367



INSTALLATION AND OPERATION INSTRUCTIONS

PLEASE READ THIS MANUAL BEFORE INSTALLING AND USING THE FIREPLACE

MODEL 4000 WH IS A.G.A. DESIGN CERTIFIED AND CGA CERTIFIED FOR NATURAL GAS AND PROPANE

Requires one or more of the following vent kits for installation:

DVK-01 - STRAIGHT OUT INSTALLATION

DVK-02 - EXTENDED STRAIGHT OUT INSTALLATION

DVK-03 - 45 DEGREE ELBOW OUT

DVK-04 - 90 DEGREE UP AND 90 DEGREE OUT INSTALLATION

DVK-05 - MINIMUM VERTICAL RISE OF 11" AND MAXIMUM HORIZONTAL RUN OF 115"

NOTE: DVK-05 IS APPROVED BY A.G.A. FOR USE WITH NATURAL GAS ONLY

DVK-06 - 90 DEGREE ELBOW KIT: VERTICAL RISE TO HORIZONTAL RUN RATIO OF 1:5

FOR YOUR SAFETY

Do not store or use gasoline or other flammable vapors and liquids in the vicinity of this or any other appliance

FOR YOUR SAFETY

If you smell gas:

- 1. Open windows.**
- 2. Don't touch electrical switches.**
- 3. Extinguish any open flame.**
- 4. Immediately call your gas supplier.**

WARNING: IMPROPER INSTALLATION, ADJUSTMENT, ALTERATION, SERVICE OR MAINTENANCE CAN CAUSE INJURY OR PROPERTY DAMAGE. REFER TO THIS MANUAL. FOR ASSISTANCE OR ADDITIONAL INFORMATION CONSULT A QUALIFIED INSTALLER, SERVICE AGENCY OR THE GAS SUPPLIER.

IMPORTANT: Read all instructions carefully before starting installation. Failure to follow these installation instructions may result in a possible fire hazard and will void the warranty.

Save this manual for future reference.

Copyright 1988, Gas Technologies, Inc. 6665 W. Hwy. 13, Savage, MN 55122 U.S.A. Printed in U.S.A.

TABLE OF CONTENTS

0.0 Overview	3
1.0 Introduction	4
2.0 Installation Precautions	4,5
3.0 Installation Instructions	6
3.1 Inside Room Installation	7
3.1.1 Positioning Fireplace	7
3.1.2 Cutting the Hole	7
3.1.3 Installing Wall Spacers	7
3.1.4 Framing	7
3.1.5 Installing Direct Vent System	8
3.2 Flush Mount Installation	8
3.2.1 Cutting The Hole	8
3.2.2 Support Platform	8
3.2.3 Building and Insulating the Chase	8,9
3.2.4 Installing Direct Vent System	9
3.3 Corner Installations	9
3.3.1 Cutting The Hole	9
3.3.2 Installing Wall Spacers	10
3.3.3 Framing	10
3.3.4 Installing Direct Vent System	10
3.4 Elevated Installation	10
3.4.1 Cutting The Hole	10
3.4.2 Installing Wall Spacers	10
3.4.3 Framing	10
3.4.4 Installing Direct Vent System	10
3.5 Permanently Positioning the Fireplace	10,11
3.6 Connecting The Gas Line	11
3.7 Electrical Wiring	12
3.8 Remote Wall Switch Wiring	12
3.9 Finishing	13
3.10 Installing Hearth Extension	13
4.0 Electrical Safety System	13
5.0 Operating Guidelines and Maintenance Instructions	14
5.1 Glass Door Removal	15
5.2 Cleaning Burner and Pilot	15
5.3 Log Replacement	15
5.4 Glass Door Replacement	15
6.0 Safety Information	16
7.0 Lighting Instructions	16
L.P. Information	17
8.0 High Altitude Installation	17
9.0 Trouble Shooting Guide	18-22
10.0 Replacement Parts	22,23
Warranty Information	24

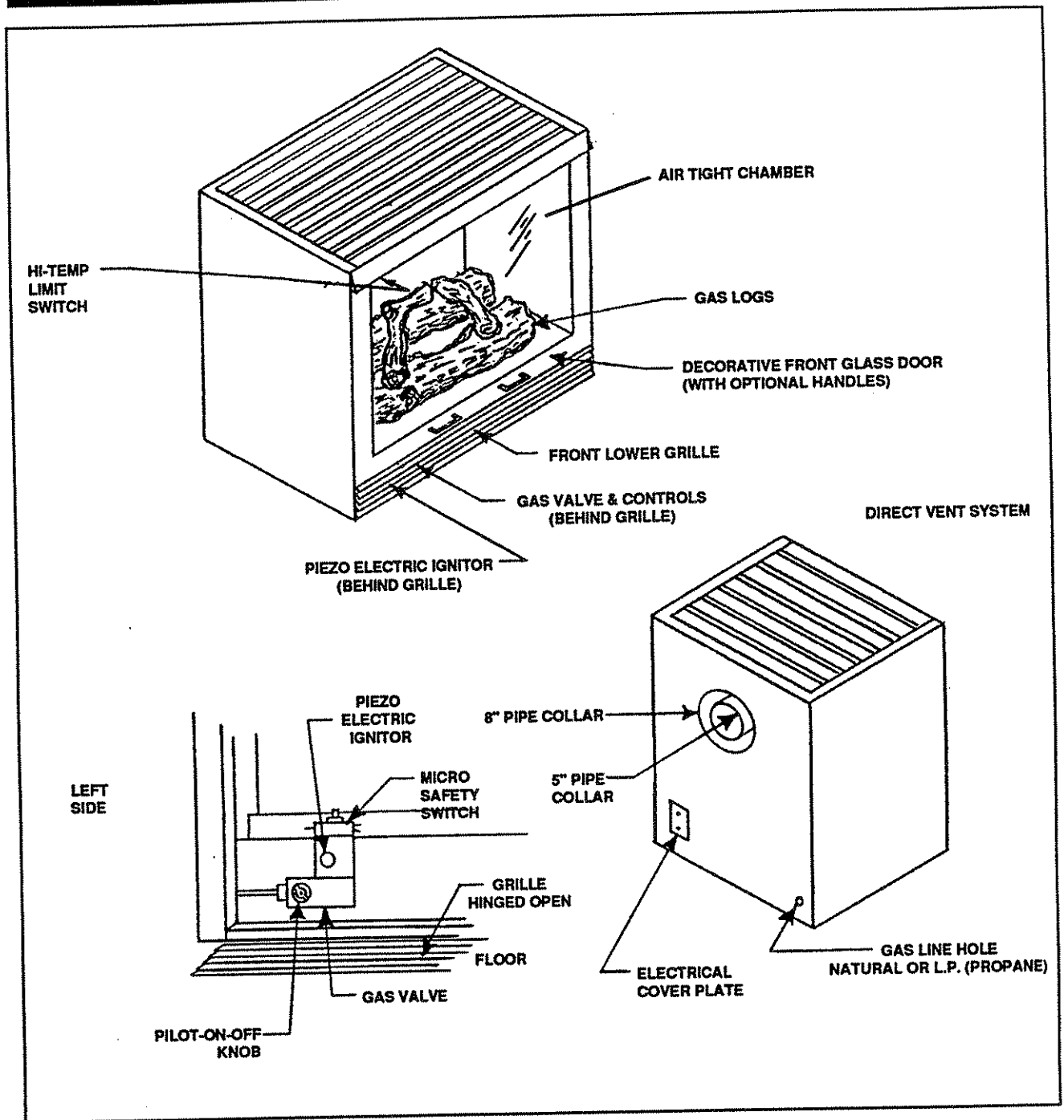

0.0 GENERAL INFORMATION

Access to the gas control and piezo electric lighter is by opening the front lower grille. Provisions have been made to attach a test gauge to the 1/8-inch NPT plugged tapping immediately upstream of the gas supply connection to the appliance.

The unit is designed to operate with all combustible air being siphoned through the coaxial pipe from the outside.

The 4000 WH must use one or more of the vent kits listed on page 1. No other pipe systems may be used.

The unit has an ON/OFF Rocker Switch. A thermostat (not provided) can be added and used as an on/off switch. See Section 3.6 for wiring instructions. Additionally, if the unit has the optional blower kit, the rheostat (variable speed control) is on the lower right behind the front grille.

1.0 INTRODUCTION

Installation must conform to local codes. In the absence of local codes installation must conform with the National Fuel Gas Code ANSI Z223.1-1988/NFPA 54-1988 (in the United States) or with the current Installation Code CAN/CGA-B 149 (in Canada). The appliance when installed must be electrically grounded in accordance with local codes; in absence of local codes, with The National Electric Code ANSI/NFPA NO 70-1987 (in the United States) or with the current CSA C 22.1 Canadian Electric Code (in Canada).



NOTE:

INSTALLATION AND REPAIR SHOULD BE DONE BY A QUALIFIED SERVICE PERSON. THE APPLIANCE SHOULD BE INSPECTED AT LEAST ANNUALLY BY A PROFESSIONAL SERVICE PERSON. MORE FREQUENT CLEANING MAY BE REQUIRED DUE TO EXCESSIVE LINT FROM CARPETING, BEDDING MATERIAL, ETC. IT IS IMPERATIVE THAT THE UNIT'S CONTROL COMPARTMENT, BURNERS, AND CIRCULATING AIR PASSAGEWAYS BE KEPT CLEAN TO PROVIDE FOR ADEQUATE COMBUSTION AND VENTILATION AIR.

Provide adequate clearances around air openings into the combustion chamber and allow accessibility clearance for servicing and proper operation. NEVER OBSTRUCT THE FRONT OPENING OF THE FIREPLACE OR THE DIRECT VENT CAP ON THE EXTERIOR OF THE HOUSE.

Minimum clearances in inches to combustibles are: Sides 2, Floor 0, Back 0, Top 24 (these clearances are defined by the standoffs). Minimum distance to the side wall (perpendicular to the front) is 2 inches. Minimum distance from the ceiling to the top front of the unit is 24 inches.

Minimum inlet gas supply pressure is 4.5 inches water column natural gas and 11 inches water column propane. Maximum inlet gas supply pressure is 10.5 inches w.c. natural gas and 13.0 inches w.c.

propane. For the purpose of input adjustment, inlet gas supply pressure should be 7.0 inches w.c. natural gas and 11.0 inches w.c. propane and manifold pressure should be set at 3.5 inches w.c. and 10.0 inches w.c. respectively.

A 1/8-inch N.P.T. plugged tapping is provided on the outlet side of the gas control for a test gauge connection to measure the manifold pressure.

The appliance and its individual shut off valve must be disconnected from the gas supply piping system during any pressure testing of the system at test pressures in excess of 1/2 psig (3.45 kPa).

This appliance must be isolated from the gas supply piping system by closing its individual manual shut-off valve during any pressure testing of the gas supply piping system at test pressures equal to or less than 1/2 psig (3.45 kPa).

2.0 INSTALLATION PRECAUTIONS

This direct vent gas fireplace and its components are tested and safe when installed in accordance with this Installation Manual. Read all instructions before starting installation and follow these instructions carefully during installation to insure maximum benefit and safety. Failure to follow them will void your warranty and may present a fire hazard.

Report to your dealer any parts damaged in shipment. Specifically, check glass condition. The logs must be positioned using the predrilled holes in the logs and the pegs on the grate provided (Figure 1). Gas logs must be properly positioned or the fireplace will not function properly and may result in soot accumulation on the inside of the firebox. See Figure 1.

The Gas Technologies, Inc. warranty will be voided by, and Gas Technologies, Inc. disclaims any responsibility for, the following actions:

- Installation of any damaged fireplace or chimney component,
- Modification of the fireplace or direct vent system,
- Installation other than as instructed by Gas Technologies, Inc.,
- Improper positioning of the gas logs or the glass door,
- Installation and/or use of any component part not manufactured or approved by Gas Technologies, Inc., notwithstanding any independent testing laboratory or other party approval of such component part or accessory.

ANY SUCH ACTION MAY POSSIBLY CAUSE A FIRE HAZARD.

Consult your local building codes.

THIS WALL HEATER AND VENT ASSEMBLY MUST BE VENTED THROUGH AN OUTSIDE WALL AND MUST NEVER BE ATTACHED TO A SOLID FUEL BURNING CHIMNEY.

WARNING: THE GLASS FRONT ASSEMBLY MUST BE IN PLACE AND THE FIXED MESH TRIM ASSEMBLY MUST BE IN PLACE ON THE FIREPLACE BEFORE THE UNIT CAN BE PLACED INTO SAFE OPERATION.

NOTE: When installing the vent kits, it is imperative that the vent cap be NO more than a 1/4" below horizontal.

NOTE: It is essential for proper unit operation that the vermiculite contained in the plastic bag be spread evenly across the bottom of the firebox.

CAUTION: NO VERMICULITE CAN BE PRESENT IN THE VERMICULITE DAM (THE 2" CIRCULAR TUBE LOCATED AT THE BASE OF THE BURNER).

NOTE: The appliance has an air-tight combustion chamber and takes 100% outside air for combustion. This appliance requires a direct vent kit (see page for details). Both Natural Gas and Propane units may be installed in a bedroom.

Prior to first firing, read Operation Instructions section of this manual.

Do not use this appliance if any part has been under water. Immediately call a qualified service technician

to inspect the heater and to replace any part of the control system and any gas control which has been under water..

DUE TO HIGH TEMPERATURE, THE APPLIANCE SHOULD BE LOCATED OUT OF TRAFFIC AREAS AND AWAY FROM FURNITURE AND DRAPERIES. CLOTHING OR FLAMMABLE MATERIAL SHOULD NOT BE PLACED ON OR NEAR THE APPLIANCE.



NOTE:

IF EXTERIOR WALLS ARE FINISHED WITH VINYL SIDING, IT IS RECOMMENDED THAT THE PROTECTION KIT (VPK-DV) DESIGNED TO BE ATTACHED TO THE TOP OF THE EXTERIOR FIRESTOP, BE INSTALLED.

This unit comes with the grate secured in place. The vent system and gas logs are in separate packages.

To install the logs remove the glass door. The gas logs must be properly positioned using the predrilled holes in the logs to position logs on the grate pegs. Open the bag of vermiculite and spread it evenly on the bottom of the firebox making sure not to block the air hole at the base of the burner. The glass door must be replaced to light the unit. THE UNIT WILL NOT OPERATE UNLESS THE GLASS DOOR IS SECURED IN PLACE.

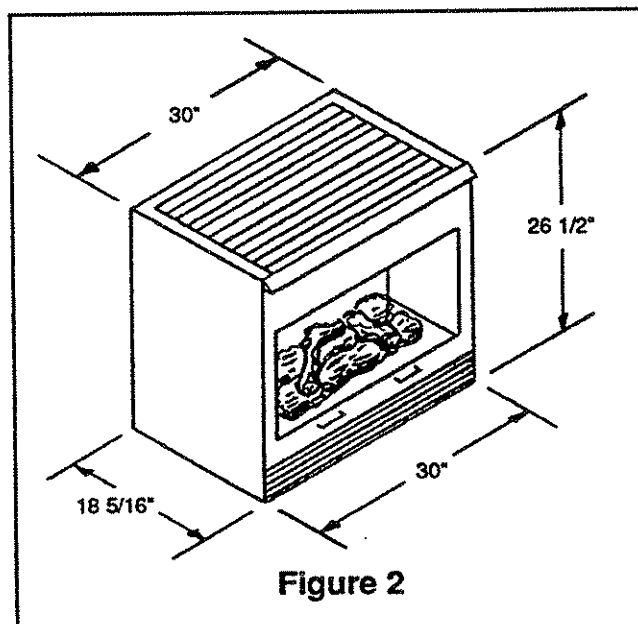
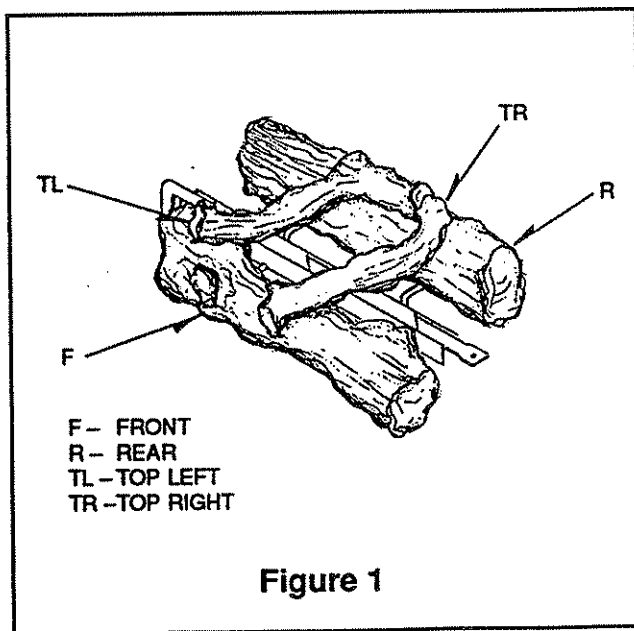

3.0 INSTALLATION INSTRUCTIONS

In planning the installation for the wall heater it is necessary to install certain components before the unit is completely positioned and installed. These include the direct vent system, gas piping for the heater and the electrical wiring (if the fan option is used).

Determine if the wall heater is to be installed inside the room (Figure 3a), corner (Figure 3b), or elevated installation (Figure 3c). Once determined refer to that section of the manual and the wall thickness tables below for the necessary vent kit(s). Detailed installation instructions are included with each vent kit and should be used in conjunction with this manual.

All installations of this heater require venting to the outside using the concentric pipe and vent cap provided.

The wall heater can be mounted on any of the following surfaces:

1. A flat combustible surface other than carpeting.
2. A raised wooden platform.
3. Outside wall

If the heater is installed directly on carpeting, tile, or other combustible material other than wood flooring, the appliance shall be installed on a metal or wood panel extending the full width and depth of the unit.

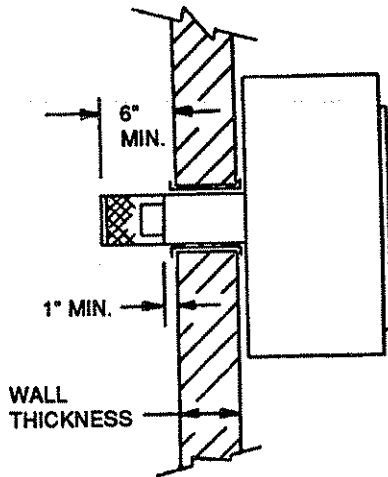

Figures 3a with table

DVK-01	Minimum	8.00"
	Maximum	13.00"
DVK-02	Minimum	13.10"
	Maximum	24.00"

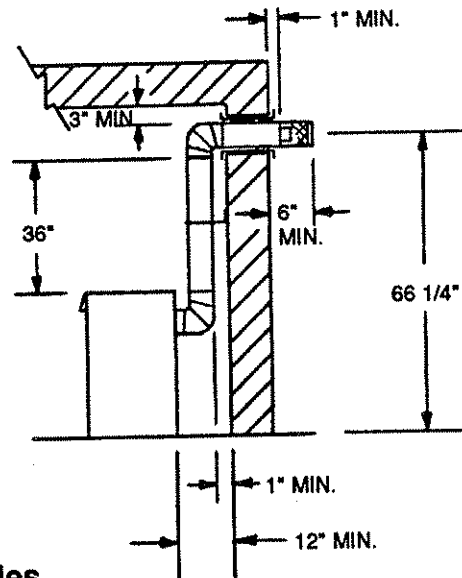
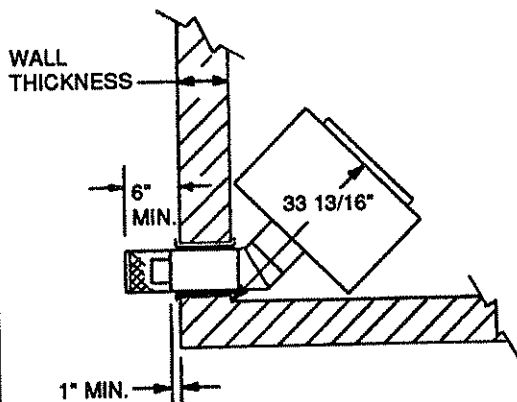

Figures 3b & c with tables

DVK-03 45° with DVK-01	Minimum	3.00"
	Maximum	8.50"
DVK-03 45° with DVK-02	Minimum	8.51"
	Maximum	20.25"

DVK-04 90° with DVK-01	Minimum	9.75"
	Maximum	15.75"
DVK-04 90° with DVK-02	Minimum	15.75"
	Maximum	24.00"

3.1 Inside Room Installation

3.1.1 Positioning the Wall Heater

Determine the exact position of the heater so the direct vent pipe is centered (if possible) between two studs. This will avoid any extra framing. Using a level, make sure the unit is properly positioned. The back of the heater may be positioned directly against a combustible wall. If a support platform is used (fig. 6) it should be a minimum of 18 3/8" x 30".

3.1.2 Cutting the Hole

After the exact position has been determined for the unit, the hole through the exterior wall of the house can be cut. This hole needs to be a 12-inch square hole with the center of the hole located 19 inches above the base of the unit (Figure 4). When locating the hole it must be noted that the bottom of the cap must be a minimum of 12 inches above the ground level and 18 inches below combustible material such as a deck. See Figure 9.

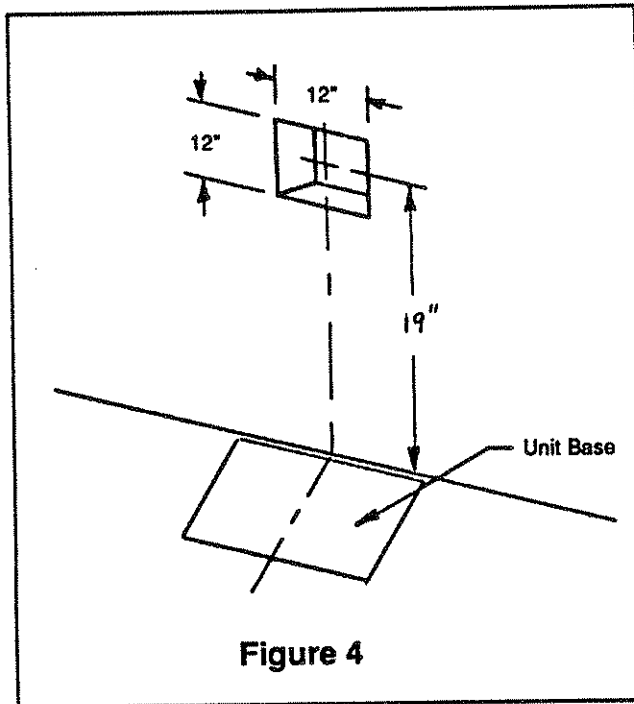

Figure 4

3.1.3 Installing Wall Spacers

Position the interior firestop over the 12-inch hole on the inside wall (Figure 5). Make sure that the spacer is put in properly (with arrows pointing up). For walls less than 8 inches thick, the pipe shield will have to be trimmed back to a flush position. The exterior firestop should be installed once the unit is permanently positioned.

UNDER NO CONDITIONS SHOULD COMBUSTIBLE MATERIAL (INCLUDING SIDING) BE CLOSER THAN 3 INCHES TO TOP OF 8-INCH PIPE OR CLOSER THAN 1 INCH ON SIDES AND BOTTOM.

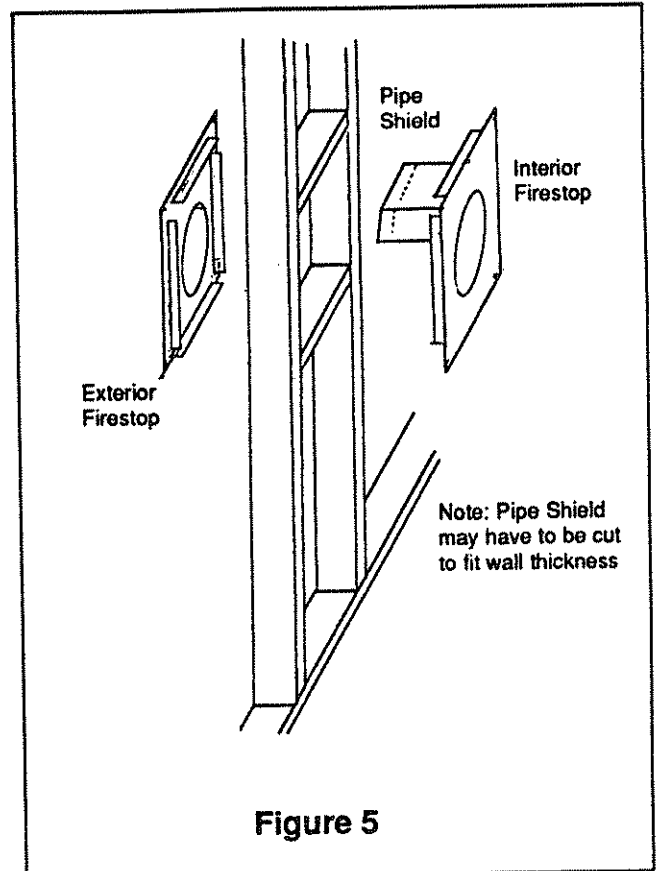

Figure 5

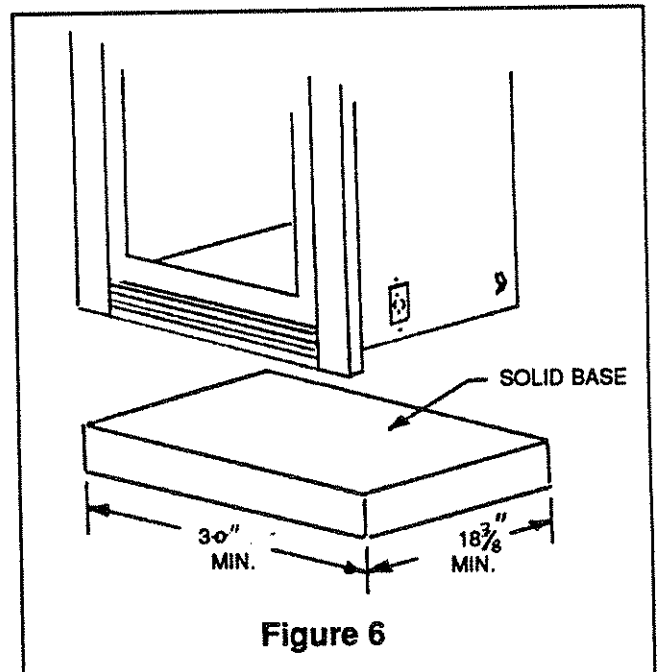
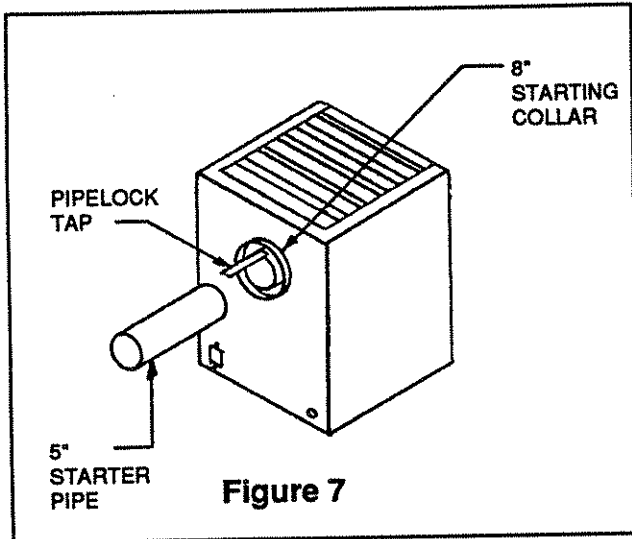

Figure 6

3.1.4 Installing Direct Vent System (Inside Room)

Measure the thickness of the exterior wall. Make sure the proper kit is being used. Attach the 5-inch inner pipe to the unit as shown in Figure 7. Make sure the seam of the pipe is facing down. Using the pipelock provided, drill a 1/8-inch hole into the pipe and secure these together with a sheet metal screw. Attach the 8-inch starter pipe to the 8-inch starter collar with a sheet metal screw. Use a non-combustible, high-temperature sealant (300° F minimum) or high temperature fiberglass rope gasketing to caulk between the 8-inch pipe and the outer skin of the fireplace. Slide the 5-inch and the 8-inch outer pipes (termination cap attached) onto the 5-inch and 8-inch inner pipes. Refer to the drawing in Figure 9, and adjust the termination cap to its final position. Using the exterior pipelock provided on the exterior firestop, secure the 8-inch pipe in place. Use a non-combustible, high-temperature sealant (300° F minimum) or high temperature fiberglass rope gasketing to caulk between the 8-inch pipe and the exterior firestop spacer.



CAUTION:

UNDER NO CONDITION SHOULD COMBUSTIBLE MATERIAL BE CLOSER THAN 3 INCHES FROM TOP OF 8-INCH PIPE WITH A 1-INCH CLEARANCE TO SIDES AND BOTTOM.



CAUTION:

TREATMENT OF WALL SPACERS MAY VARY WITH THE TYPE OF BUILDING. THESE INSTRUCTIONS ARE NOT SUBSTITUTES FOR THE REQUIREMENTS OF LOCAL BUILDING CODES. THEREFORE, YOUR LOCAL BUILDING CODES MUST BE CHECKED TO DETERMINE THE REQUIREMENTS FOR THESE STEPS.

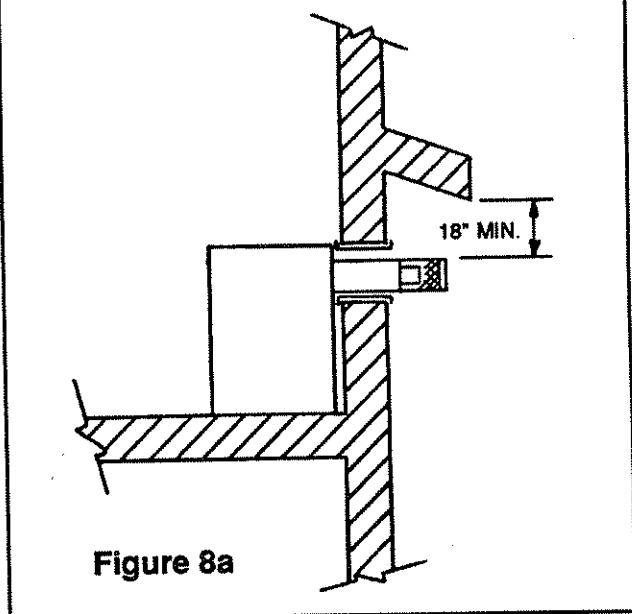
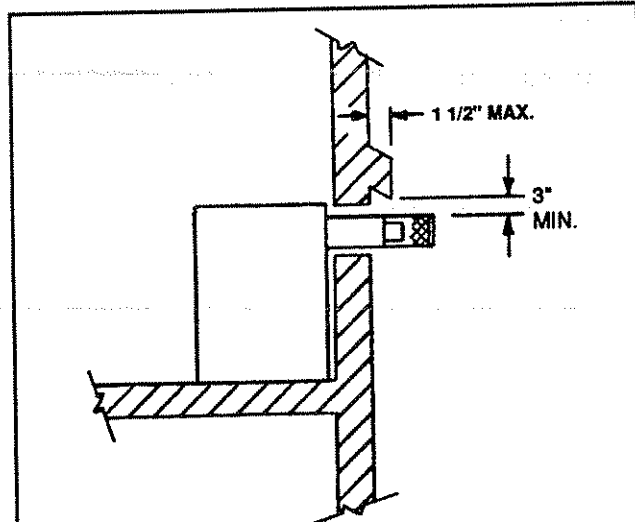

NOTE: WHEN FINISHED, THE CAP SHOULD BE AS SHOWN IN FIGURE 9, WITH THE CAP EXTENDED PAST THE EXTERIOR FIRESTOP A MINIMUM OF 5 1/2 INCHES.

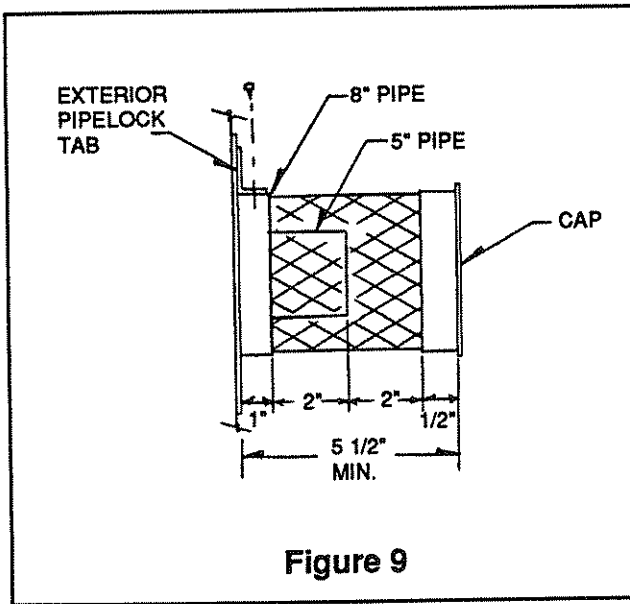

3.2 Corner Installations

Corner installations require the use of the vent kits DVK-03 and DVK-01 or DVK-02 depending upon wall thickness. Check wall thickness to be sure the proper kit is being used. The DVK-03 can be used for a left or right hand installation. Detailed instructions for the DVK-03 are included with the kit. It is important that all 5" joints be tightly sealed and secured to insure that the unit functions properly.

3.2.1 Cutting the Hole

The unit is designed to sit in the corner at an exact 45 degree angle. With the unit in position the hole location is as shown in Figure 10. The location to the center of the hole is 19 inches up from the base of the unit and 8 5/8 inches from hole center to inside corner of the house.

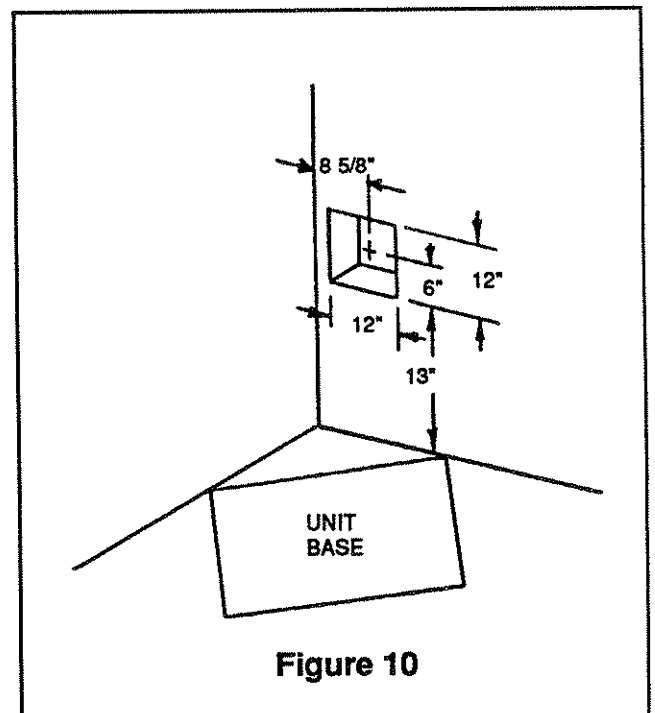

3.2.2 Installing Wall Spacers

Refer to Section 3.1.3.

3.2.3 Installing Direct Vent System (Corner)

Attach the 45°, 5 inch and 8 inch elbow assembly by sliding the uncrimped ends of the elbows to the crimped starting collars on the unit. Secure the 8 inch collar-elbow connection with two (2) screws. Measure the thickness of the exterior wall and adjust telescoping pipe. Put the 5-inch pipe on the elbow and lock into position with the screws provided, doing the same with the 8-inch pipe. Slide the unit into position making sure the pipe slides through the interior fire stop.

3.3 Elevated Installation

Elevated Installations require the use of vent kits DVK-04 and DVK-01 or DVK-02. These kits can be used for a left or right installation. This system can also be installed up against a back wall. Detailed instructions for the DVK-04 are included with the kit.

3.3.1 Cutting the Hole

The hole is to be 12 inches square. When locating the hole it must be noted that the bottom of the cap must be 12 inches above the ground level. This is a minimum clearance. You must also maintain a minimum of 3 inches clearance from the ceiling as shown in Figure 11. The maximum rise in the vertical position is a 3-foot section of center pipe. This will make the center of the exhaust hole 66 1/4 inches above the base of the fireplace. If the required height is less than 66 1/4 inches, then the 3-foot lengths of pipe must be cut on the non-crimped end to accommodate the required height. The minimum vertical

rise for the DVK-04 installation is 11".

3.3.2 Installing Wall Spacers

Refer to Section 3.1.3

3.3.3 Installing Direct Vent System (Elevated)

Attach the lower 5-inch and 8-inch 90 degree elbow system with the screws provided. Next attach the 5-inch x 36-inch pipe, using three screws for assembly. Do the same for the 8-inch x 36-inch pipe. Then attach the second elbow system in the same manner. Before sliding the unit into position, attach the 5-inch and 8-inch vent pipes in the top elbows, securing them with screws and tabs provided. Slide the unit into position and guide the vent pipes through the interior firestop.

The exterior firestop (8-inch-diameter hole) may now be placed over the pipe on the outside of the house and nailed in position, again the arrows must point up to provide proper clearances. When finished, the cap should be as shown in Figure 9, with the cap extended past the exterior firestop a MINIMUM of 5 1/2 inches.

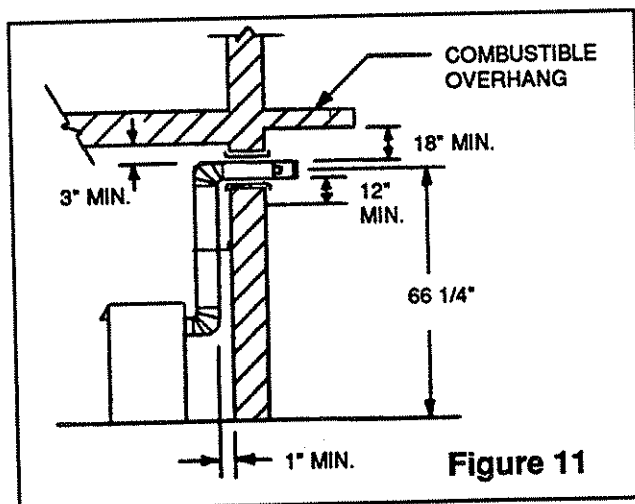

3.4 Connecting the Gas Line

The gas wall heater is designed to accept a 3/8 inch gas line for an approved gas appliance. Have the gas line installed by a qualified service person in accordance with all building codes. Consult local building codes to properly size the gas supply line leading to the 3/8 inch reduction for hook-up at the unit. It is recommended to assemble a gas pipe train as shown in Figure 14. Use a 3/8" nipple, drip "T", union, and male/female manual gas shut-off valve. A 1/8" N.P.T. plugged tapping, accessible for test gauge connection, should also be provided for, in the pipe train.

Locate the gas line access hole in the left outer rear casing of the unit (Figure 12).

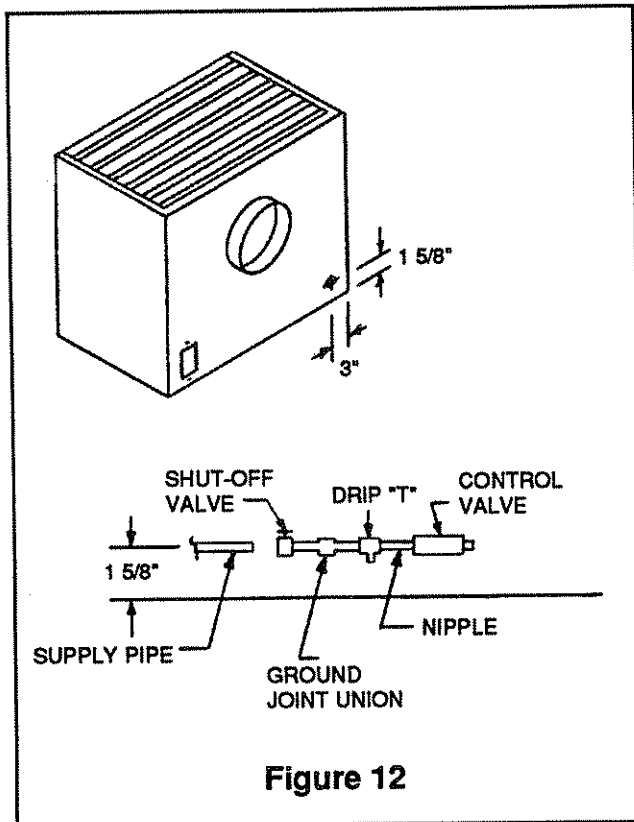

Next, insert the gas pipe train through the gas line hole from the outside of the fireplace and connect it to the gas valve. Support the control when attaching the pipe so that the pilot line is not bent or torn. After the gas pipe installation is complete, check carefully all gas connections for leaks with a soap solution. **DO NOT USE AN OPEN FLAME.** Use insulation to repack the space around the pipe. This should be inserted from the outside of the fireplace and packed tightly to totally seal between the pipe and the outer casing.



NOTE:

THE GAS PIPE SHOULD NOT COME IN CONTACT WITH ANY WOOD STRUCTURES UNTIL IT HAS REACHED A POINT AT LEAST 1 INCH AWAY FROM THE FIREPLACE SIDE.

NOTE: THE GAS SUPPLY LINE SHOULD BE PURGED OF ANY TRAPPED AIR PRIOR TO THE FIRST FIRING OF THE UNIT.

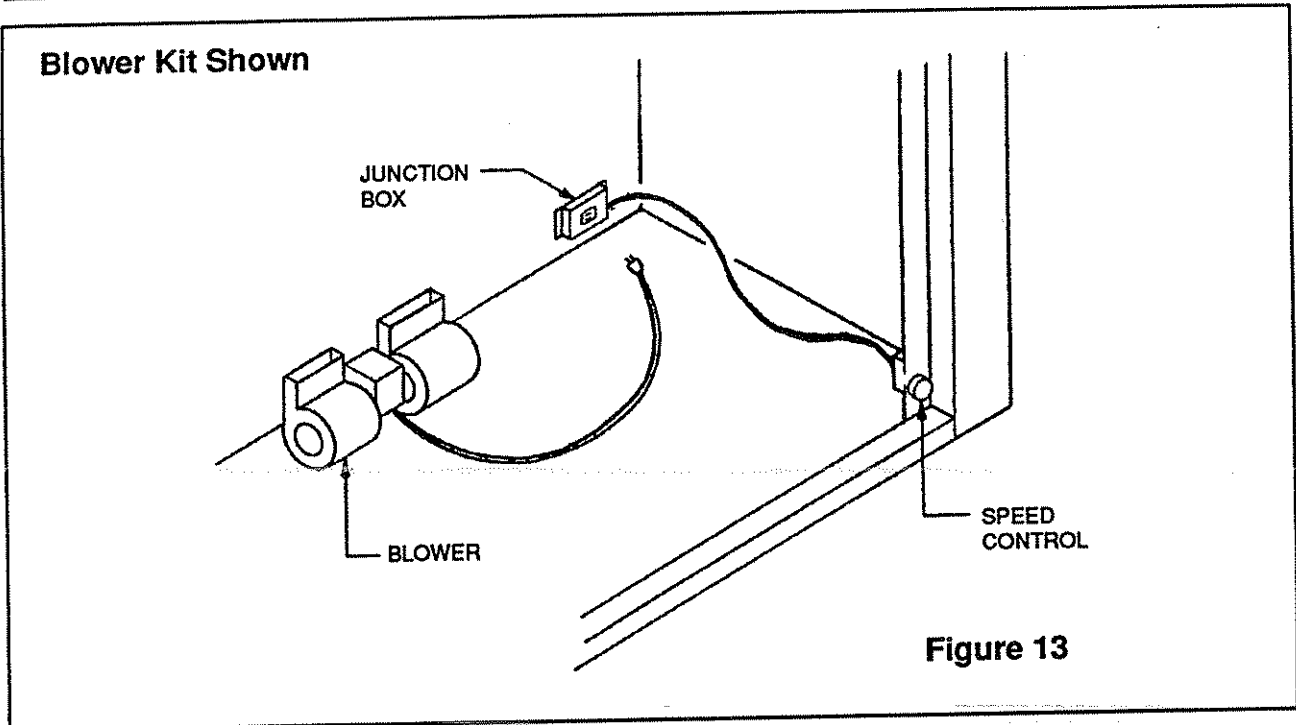

3.5 Electrical Wiring See Addendum "A"

An optional blower kit (WFK-160) is available (Fig. 13). A junction box and 3-prong electrical cord is installed in the unit. After installing the blower kit, simply plug the cord into a 3-prong 110 VAC electrical outlet. Detailed instructions for the blower installation come with the kit.

WARNING: DO NOT CONNECT 110-120 VAC TO THE GAS CONTROL VALVE

3.6 Thermostat Wiring See Addendum "A"

A thermostat (millivolt type only) must be wired to the control valve of this appliance (Fig. 14). Attach one low voltage wire from the thermostat to the "TH" (#3) terminal of the gas control valve. Connect the other low voltage wire from the "TH-TP" (#1) terminal of the valve. After lighting the pilot, adjust thermostat to desired setting.

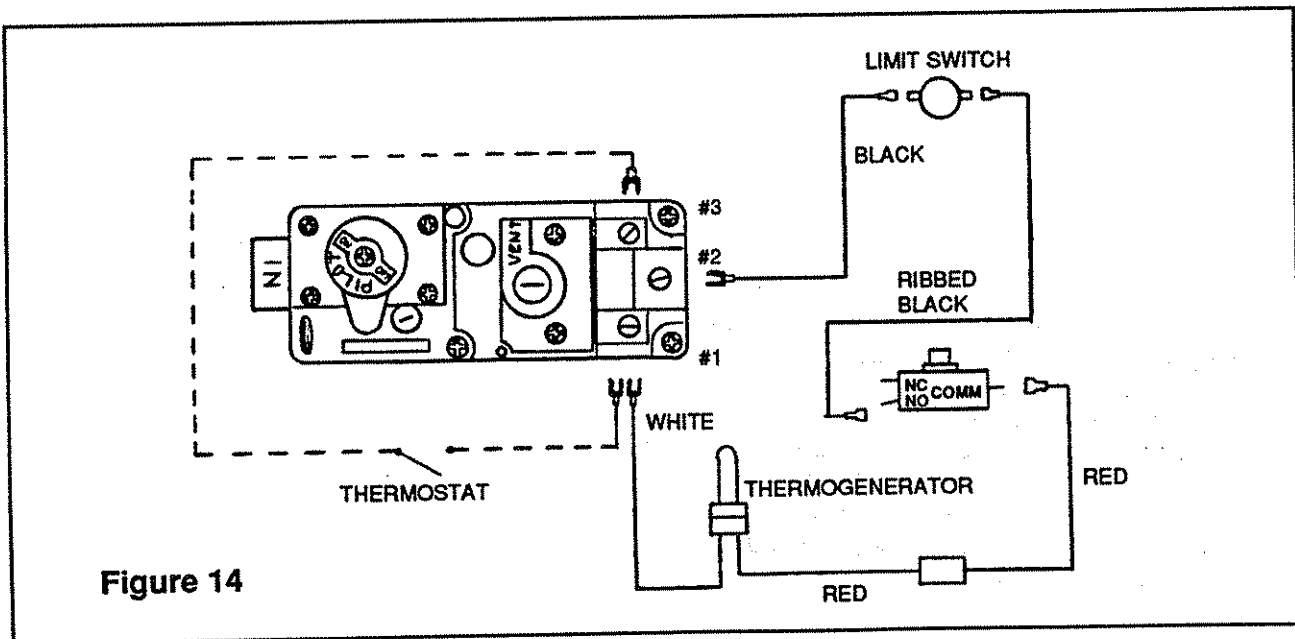



NOTE:

NOTE: POSITION THE THERMOSTAT SO THAT A MAXIMUM OF 25 FEET OF WIRING FROM THE SWITCH TO THE WALL HEATER IS USED, AND SO THAT IT IS 4 FEET MINIMUM FROM THE FLOOR.

3.7 Finishing



CAUTION:

When installing the wall heater NEVER OBSTRUCT OR MODIFY THE AIR INLET/OUTLET GRILLES IN ANY MANNER.

Do not install a combustible mantle or other combustible projection above the heater opening unless it is a minimum of 24 inches above the top of the unit (Figure 15).

DO NOT put any finishing material on the Vent Cap. **DO NO** extend the roofing material more than 1-1/2 inches beyond the outside wall, unless the roofing material is at least 18 inches above the cap (see Figure 8A).

3.8 Installing Hearth Extension

While a hearth extension may be desirable for aesthetic reasons, it is not required for direct vent gas fireplaces with fixed screen fronts.

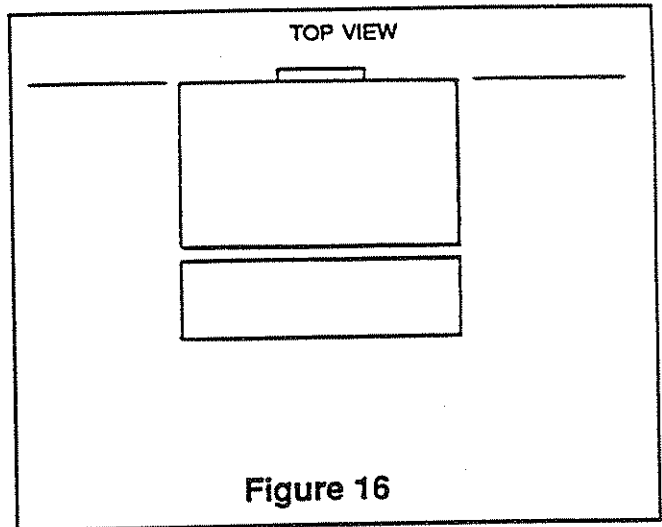
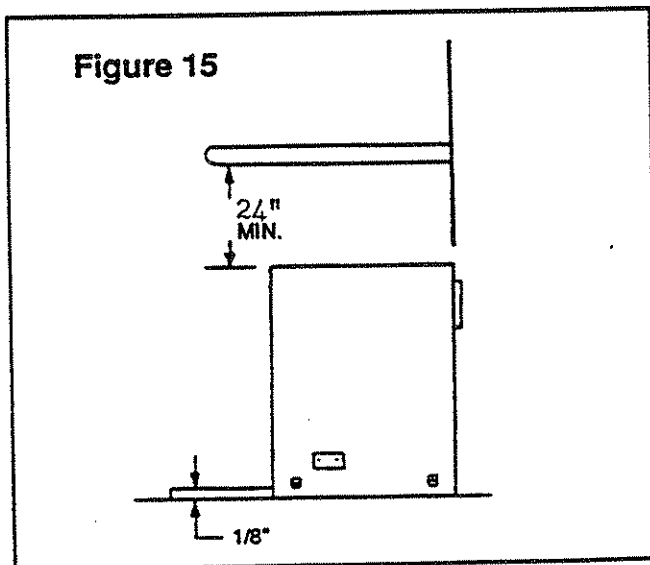

3.9 Electrical Safety System

WARNING: DO NOT CONNECT 110-120 VAC TO THE GAS CONTROL VALVE.

The 4000WH system is wired so the thermo-generator, when heated with the pilot light, will provide approximately 350-500 millivolts. This activates the gas control valve. For protection, the glass door must be in closed position to work (this activates the microswitch). Additionally, a high temperature limit switch is used for protection and would close the main gas valve should a high surface temperature condition be encountered (Figure 17).

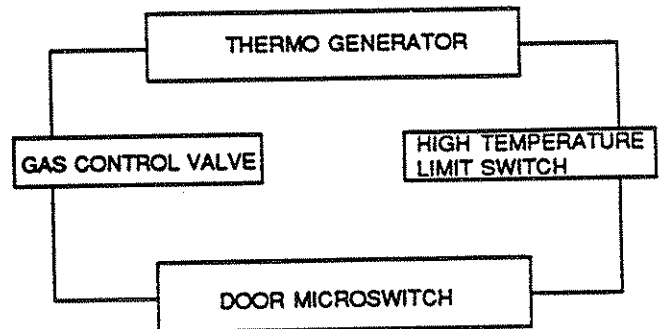

4.0 OPERATING GUIDELINES MAINTENANCE INSTRUCTIONS

Upon completing your gas line connection, a small amount of air will be in the lines. When first lighting the pilot light, it will take a few minutes for the lines to purge themselves of this air. Once the purging is complete, the pilot and burner will light and operate as indicated in the instruction manual. Subsequent lightings of the appliance will not require such purging.

CAUTION: DURING THE INITIAL PURGING AND SUBSEQUENT LIGHTING'S **NEVER** ALLOW THE GAS VALVE CONTROL KNOB TO REMAIN DEPRESSED IN THE "PILOT" POSITION WITHOUT PUSHING THE RED IGNITOR BUTTON AT LEAST ONCE EVERY SECOND.

When lit for the first time, the appliance will emit a slight odor for an hour or two. This is due to paint and lubricants used in the manufacturing process. Additionally, for the first few minutes after each lighting, vapor may condense and fog the glass and the flames may be blue. After a few minutes this moisture will disappear and within 15-30 minutes the flames should become yellow.

Keep the control compartment, logs, and burner area surrounding the logs clean by vacuuming or brushing at least twice a year.



CAUTION:

THE LOGS CAN GET VERY HOT - HANDLE ONLY WHEN COOL.

Always turn off gas to the pilot before cleaning. For relighting, refer to lighting instructions located behind the lower front grille assembly.

The appliance and venting system should be inspected before initial use and at least annually by a qualified field service person.

Always keep the appliance area clear and free from combustible materials, gasoline, and other flammable vapors and liquids.

Never obstruct the flow of combustion and ventilation air. Keep the front of the appliance clear of all obstacles and materials.

Your appliance control system is a millivolt type. It consists of a pilot burner, a piezo ignitor, a gas control valve regulator, a microswitch, an ON/OFF rocker switch and a safety high temperature limit switch.

To obtain proper operation, it is imperative that the pilot and main burner flame characteristics are steady, not lifting or floating.

Typically, the top 3/4-inch at the pilot generator should be engulfed in the pilot flame (Figure 18).

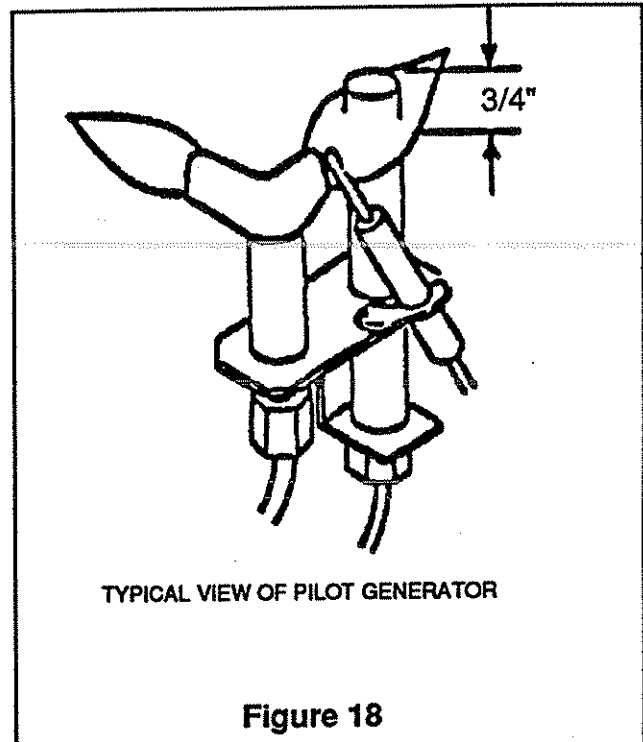

WARNING:

CHILDREN AND ADULTS SHOULD BE ALERTED TO THE HAZARDS OF HIGH SURFACE TEMPERATURE AND SHOULD STAY AWAY TO AVOID BURNS OR CLOTHING IGNITION. YOUNG CHILDREN SHOULD BE SUPERVISED WHEN THEY ARE IN THE SAME ROOM AS THE APPLIANCE.



IMPORTANT:

TURN OFF GAS BEFORE SERVICING APPLIANCE. IT IS RECOMMENDED THAT A COMPETENT SERVICEMAN PERFORM THESE CHECKUPS AT THE BEGINNING OF EACH HEATING SEASON.

Inspect the external vent cap on a regular basis to make sure that no debris is interfering with the air flow.

4.1 GLASS DOOR REMOVAL

1. To remove the glass panel, the rectangular fixed mesh trim assembly must be removed first. To do this, lift and pull from the top above the glass panel.
2. Noting carefully how the brackets fit on the glass, remove wing nuts and brackets from the glass door.
3. Glass door is now ready for removal.

4.2 CLEANING BURNER AND PILOT

In order to properly clean the burner and pilot assembly, turn off the gas to the unit and remove the logs exposing the burner and pilot assembly.

Clean all foreign materials from top of burner. Check to make sure that burner orifice is clean.

Visually inspect pilot. Brush or blow away any dust or linen accumulations. If pilot orifice is plugged, disassembly may be required to remove any foreign material from orifice or tubing. When appliance is put back in service check burner flame patterns with Figure 19.

4.3 Log Replacement

1. Remove the mesh trim assembly (see Section 5.1).
2. The Log(s) can now be removed as required. Replace the log(s) as previously shown in Figure 1 Gas Log Positioning. Replace glass door and mesh trim assembly.

4.4 Glass Door Replacement

1. Before replacing the glass door make sure the vermiculite material is spread evenly over the bottom of the firebox and the logs are properly positioned.
2. Center the glass door and place the bottom lip of glass door firmly on top of the MICRO SWITCH push button.



NOTE:

IF GLASS DOES NOT PUSH AGAINST THE MICROSWITCH, THE PILOT WILL NOT STAY ON.

3. With glass door in place push glass against unit and at the same time put brackets on upper portion of door and tighten the wing nuts provided.

4. Attach the brackets at the bottom of the glass and hand tighten.



NOTE:

WING NUTS THAT SECURE THE GLASS ONLY NEED TO BE HAND TIGHTENED. TO GIVE A SNUG FIT FOR PROPER GASKET SEAL. OVERTIGHTENING MAY RESULT IN DAMAGED GLASS.

5. Replace fixed mesh trim assembly proceeding in reverse order of step 1 under Glass Removal.

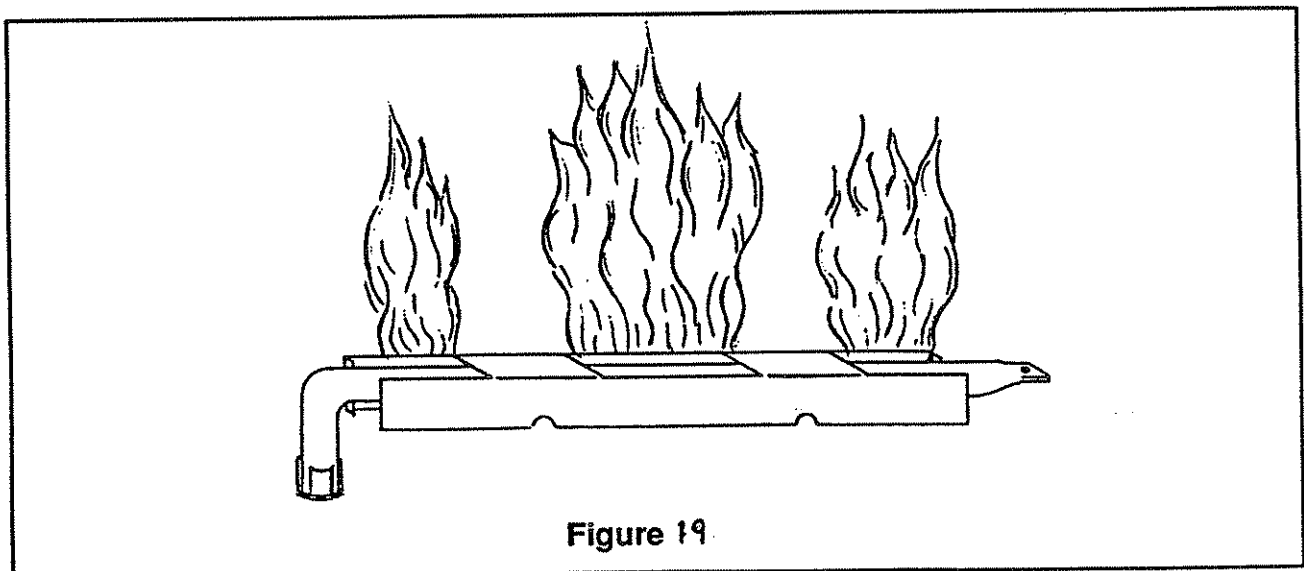

Figure 19

5.0 SAFETY INFORMATION

"FOR YOUR SAFETY READ BEFORE LIGHTING"

IF YOU DO NOT FOLLOW THESE INSTRUCTIONS EXACTLY, A FIRE OR EXPLOSION MAY RESULT CAUSING PROPERTY DAMAGE., PERSONAL INJURY, OR LOSS OF LIFE.

A. This appliance has a pilot. When lighting the pilot, follow these instructions exactly.

B. **BEFORE LIGHTING** smell all around the appliance area for gas. Be sure to smell next to the floor because some gas is heavier than air and will settle on the floor.

WHAT TO DO IF YOU SMELL GAS

- o Do not try to light any appliance
- o Do not touch any electric switch: do not use any phone in your building.
- o Immediately call your gas supplier from a neighbor's phone. Follow the gas supplier's instructions.
- o If you cannot reach your gas supplier, call the fire department.

C. Use only your hand to push in or turn the gas control knob. Never use tools. If the knob will not push in or turn by hand, don't try to repair it. Call a qualified service technician. Forced or attempted repair may result in a fire or explosion.

D. Do not use this appliance if any part has been under water. Immediately call a qualified service technician to inspect the appliance and to replace any part of the gas control system which has been under water.

6.0 LIGHTING INSTRUCTIONS

1. **"STOP!"** Read the safety information above first.
2. To access controls pull top of lower grille forward. The grille is hinged to open downward.
3. Turn the control to the OFF position. To do this, you must turn the knob clockwise to the pilot position, and then press in and continue turning clockwise to the OFF position.
4. **WAIT FIVE (5) MINUTES TO CLEAR OUT ANY GAS.** If you then smell gas, **STOP!** Follow "B" in the safety information above. If you don't smell gas, go to next step.

5. The pilot should not require accessing for lighting purposes. The pilot is located inside the air tight chamber. If it is necessary to access the pilot, follow the instructions in Section 5.1 for glass door removal.

6. To put the control in the pilot position, turn the control knob counter-clockwise to the pilot position.

7. To light the pilot depress the control knob and then depress the red piezo button until it makes a clicking sound. It may be necessary to repeat this step. If the pilot does not light after 10 seconds, go back to step 3. The control knob should be held down for a **MINUTE** after pilot ignition. If the pilot lights but will not stay lit after two tries, turn the gas control knob to the "OFF" position and call your service technician or gas supplier. If the control knob does not pop out when released, **STOP**-shut off the gas supply to the fireplace control valve, and **IMMEDIATELY** call your service technician or gas supplier.

8. After the pilot has been lit, the burner can be turned on by turning knob counter-clockwise to the "ON" position. Then flip the ON/OFF rocker switch to the "ON" position.



NOTE:

NOTE: THE TIPS OF THE FLAMES SHOULD NEVER HIT THE TOP OF THE FIREBOX.

9. To close control panel simply lift grille and press in.

10. To turn off gas to appliance:

- a. Flip on/off switch to "OFF"
- b. Open access grill by pulling grille top forward.
- c. Turn knob clockwise to pilot position then depress knob and continue turning to "OFF" position.
- d. To close control panel simply lift grill and press in.

After the unit has warmed up (i.e. approx. 15 min.), flame height should be slightly (about 2") below the top of the decorative front (Figure 20). If the flame height is higher than this, adjustments must be made to prevent overheating the gasket and glass. Please contact your dealer or a qualified service person to replace the orifice or adjust the valve.

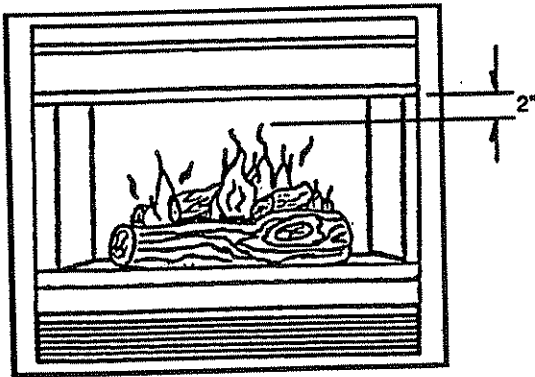

Figure 20

L.P. INFORMATION

THE FOLLOWING WARNING APPLIES TO INSTALLATIONS USING L.P., PROPANE GAS:



WARNING:

Warning: To avoid possible injury, fire, and explosion, please read and follow these precautions and all instructions on this appliance before lighting the pilot. This appliance uses L.P. (Propane) gas which is heavier than air and will remain at floor level if there is a leak. Before lighting, smell at floor level and/or use other means (such as using a soap solution on all piping and connections, using a gas detector, etc.) to check for gas leaks. **NOTE:** L.P. (Propane) gas can become odorless and **CANNOT** always be detected by smell. If you smell gas, detect a gas leak, or suspect that a gas leak exists, follow these rules:

1. Get all people out of building.
2. **DO NOT** light matches. **DO NOT** turn electric lights or switches on or off in area. **DO NOT** use an electric fan to remove gas from area. **DO NOT** use a telephone inside the building.
3. Shut off gas at L.P. tank outside of building.
4. Telephone gas company and fire department. Ask instructions.

Before hanging up, give your name, address, and phone number. **DO NOT** go back into building.

If your L.P. tank runs out of fuel, turn off gas at the appliance. After L.P. tank is refilled, appliance must be re-lit according to manufacturer's instructions. If the gas control has been exposed to **WATER** in any way, **DO NOT** try to use it. It must be replaced. **DO NOT** attempt repair on gas control or appliance.

Tampering is **DANGEROUS** and voids all warranties. Any component that is found to be faulty, must be replaced with an approved component.

7.0 HIGH ALTITUDE INSTALLATION

A.G.A. Design Certified units are tested and approved for elevations from 0-2000 feet. CGA approved units are certified for elevations from 0-4500 feet.

When installing this unit at an elevation above 2000 feet, (in United States) it is necessary to decrease the input rating by changing the existing burner orifice to a smaller size. Input should be reduced 4 percent for each 1000 feet above sea level.

When installing this unit at an elevation between 0-4500 feet (in Canada) the input rating does not need to be reduced.

When installing this unit at an elevation above 4500 (in Canada), check with local authorities.

Consult your local gas company for assistance in determining the proper orifice for your location.

9.0 TROUBLE SHOOTING - 4000WH

With proper installation and maintenance, your new Gas Fireplace should provide years of trouble-free service. If you do experience a problem, refer to the trouble shooting guide shown below. This guide will assist a qualified service person in the diagnosis of problems and the corrective action to be taken.

SYMPTOM	POSSIBLE CAUSE	CORRECTIVE ACTION
I. Spark Ignitor will not light pilot after repeated triggering of red button.	A. Defective ignitor (no spark at electrode).	1. Check for spark at electrode and pilot; if no spark and electrode wire is properly connected, replace ignitor.
	B. Defective pilot or misaligned electrode (spark at electrode).	1. Using a match, light pilot. If pilot lights, turn off pilot and trigger the red button again. If pilot lights, an improper gas/air mixture caused the bad lighting and a longer purge period is recommended. If pilot will not light - check gap at electrode and pilot - should be 1/8 inch to have a strong spark. If OK, replace pilot.
	C. No gas or low gas pressure.	1. Check remote shut off valves from fireplace. Usually there is a valve near the fireplace and sometimes there is a valve near the main. There can be more than one (1) valve between the fireplace and main. 2. Low pressure can be caused by a variety of situations such as a bent line, too narrow diameter of pipe or even low line pressure. Check for kinked lines. If none, consult with plumber or gas supplier.
	D. No L.P. in tank.	3. Check L.P. (Propane) tank. You may be out of fuel.
II. Pilot will not stay lit after care-fully following lighting instructions.	A. Defective thermo-generator.	1. Check pilot flame. Must impinge on thermo-generator. Clean and or adjust pilot for maximum flame impingement on generator. 2. Be sure wire connections from generator at gas valve terminals are tight and generator is fully inserted into pilot bracket.

SYMPTOM	POSSIBLE CAUSE	CORRECTIVE ACTION
III. Pilot burning, no gas burner, valve knob "ON", ON/OFF switch "ON".	B. Defective valve.	<p>3. Check thermo-generator with millivolt meter. Take reading at "TH -TP & TP" terminals of gas valve. Should read 325 millivolts minimum while holding valve knob depressed in pilot position, pilot lit, and ON/OFF switch "OFF". Replace faulty generator if reading is below specified minimum.</p> <p>1. Disconnect the Thermo-generator's red wire from the microswitch and connect to terminal "TP" on the gas valve. Connect the millivolt meter probes to the "TH TP" and "TP" terminals on the gas valve. Turn the green knob to pilot position, depress and light pilot light. If meter reading is greater than 325 m.v. after 30 seconds the pilot generator is good. If pilot does not stay lit, the valve is defective. If the meter reading is less than 325 m.v., the Thermo-generator is defective.</p>
	C. Glass door does not fully depress Microswitch.	<p>1. Adjust glass so it fully depresses the Microswitch. (Do not operate the unit with broken or cracked glass).</p> <p>2. If fully depressed, place jumper wires across connectors and if it allows you to re-ignite, the switch should be replaced. Do not operate unit with jumper wires in place. When the jumper wire is in place and the unit won't re-ignite, you may have problems with the wiring or connectors.</p>
	D. Open wire connection in pilot circuit.	<p>1. Check wire continuity and connections in pilot circuit.</p>
	A. ON/OFF switch or wires defective.	<p>1. Check ON/OFF switch and wires for proper connections. Place jumper wires across terminals at switch - if burner comes on, replace defective switch. If OK, place jumper wires across switch wires at gas valve - if burner comes on, wires are faulty or connections are bad.</p>

SYMPTOM	POSSIBLE CAUSE	CORRECTIVE ACTION
IV. Frequent pilot outage problem.	B. Thermo-generator may not be generating sufficient millivoltage. (325 m.v.)	<ol style="list-style-type: none"> 1. Recheck Symptom #2. 2. Pilot flame not physically close enough to thermo-generator.
	C. Defective valve.	<ol style="list-style-type: none"> 1. Turn valve knob to "ON", place ON/OFF switch to "ON". Check with millivolt meter at generator terminals. Millivolt meter should read greater than 100 m.v. If the reading is okay and the burner does not come on, replace the gas valve.
	D. Plugged burner orifice.	<ol style="list-style-type: none"> 1. Check burner orifice for stoppage and remove.
V. Pilot and main burner go out while being in operation.	A. Pilot flame may be too low or blowing (high), causing the pilot safety to drop out.	<ol style="list-style-type: none"> 1. Clean and adjust pilot flame for maximum flame impingement on thermo-generator.
	A. High limit switch is defective or has reached its maximum temperature.	<ol style="list-style-type: none"> 1. Allow unit to cool. Then repeat lighting instructions. 2. If 1 above does not allow for ignition, check high limit switch. Place jumper wires across high limit switch. If you can re-ignite the pilot, your high limit switch is defective. Do not use fireplace until the high limit switch is replaced, as this is an important safety feature. If the unit does not light with jumper wires in place, the wires may be defective or the connectors are bad.
	B. Door microswitch is not fully depressed or defective.	<ol style="list-style-type: none"> 1. Adjust glass so it fully depresses the Microswitch. (Do not operate unit with broken or cracked glass). 2. If fully depressed, place jumper wires across connectors and if it allows you to re-ignite, the switch should be replaced. Do not operate unit with jumper wires in place. When jumper wire is in place and the unit won't re-ignite, you may have problems with the wiring or connectors.

SYMPTOM	POSSIBLE CAUSE	CORRECTIVE ACTION
	C. No L.P. in tank.	1. Check L.P. (Propane) tank. You may be out of fuel.
	D. Inner 5-inch pipe leaking exhaust gases back into system.	1. Check for leaks.
	E. Horizontal vent improperly pitched.	1. Horizontal vent should slope down only enough to prevent any water from entering unit. The maximum downward slope is 1/4" for any horizontal run.
	F. Glass too loose and air tight gasket leaks in corners after usage.	1. Tighten corner.
	G. Bad thermo-generator.	1. Replace if necessary.
	H. Improper vent cap installation.	1. Check for proper installation & freedom from debris or blockage.
VI. Glass soots.	A. Flame impingement on logs.	1. Adjust the log set so that the flame does not impinge on it.
	B. Improper venturi setting.	1. Adjust the air shutter at the base of the burner.
	C. Vermiculite around venturi.	1. Inspect the opening in the vermiculite dam at the base of the burner. It is imperative that <u>NO</u> material be placed in this opening.
VII. Flame burns blue and lifts off burner.	A. Insufficient oxygen being supplied.	<p>1. Check to make sure vent cap is installed properly and free of debris. Make sure that the 5-inch inner pipe extends 2-inches beyond the 8-inch pipe and has no leaks in it.</p> <p>2. Check to make sure that the vermiculite has not been improperly placed in the vermiculite dam down at the burner base.</p> <p>3. Be sure glass is tightened properly on unit, particularly on top corners.</p>

LIMITED WARRANTY POLICY FOR GAS TECHNOLOGIES, INC. GAS FIREPLACES

The limited two year warranty will not become effective until the completed warranty card has been mailed to GAS TECHNOLOGIES, INC., Savage, MN 55378.
This card must be mailed within 60 days of the fireplace installation.

Subject to the conditions set forth herein, Gas Technologies, Inc. extends the following limited warranty with respect to Gas Technologies, Inc. Decorative Gas Fireplaces.

If Gas Technologies, Inc. is satisfied that any part or portion of the fireplaces covered by this warranty is defective in material or workmanship under normal use and service as described in the operating instructions, Gas Technologies, Inc. will take the following actions:

1. Within the first year from the date of installation, Gas Technologies, Inc. shall, at its option, replace or repair any such defect in material or workmanship, at Gas Technologies, Inc. expense. GAS TECHNOLOGIES, INC. SHALL NOT BE RESPONSIBLE FOR ANY OTHER LABOR COSTS, OR EXPENSES, INCLUDING INDIRECT, INCIDENTAL OR CONSEQUENTIAL DAMAGES.
2. During the second year after the date of installation, GAS TECHNOLOGIES, INC. shall supply replacement parts at the current minimum wholesale price, but GAS TECHNOLOGIES, INC. SHALL NOT BE RESPONSIBLE FOR ANY LABOR, TRANSPORTATION, OR OTHER INDIRECT, INCIDENTAL, OR CONSEQUENTIAL DAMAGES.
3. During the first six months after installation, GAS TECHNOLOGIES, INC. shall, at its option, replace or repair the glass door if operation is faulty (this does not include glass panels broken during shipping, misuse or careless handling). GAS TECHNOLOGIES, INC. SHALL NOT BE RESPONSIBLE FOR ANY LABOR, TRANSPORTATION OR OTHER INDIRECT, INCIDENTAL, OR CONSEQUENTIAL DAMAGES. IF GLASS DOORS OTHER THAN FACTORY DOORS ARE USED, ALL WARRANTY AND LIABILITY ON THE FIREPLACE IS VOIDED.
4. All electrical, manual, and optional components or accessories found to be defective will be repaired or replaced without charge during the first year after installation.

Gas Technologies, Inc. may discharge its entire warranty liability by refunding the price of the product.

Products made by other manufacturers, sold with the fireplace or thereafter are not covered by this limited warranty. The use of other unauthorized components will make this warranty null and void.

This limited warranty will be void if the appliance is not installed by a qualified installer and according to the installation instructions. The limited warranty also is void if the fireplace is not operated, at all times, according to the operating instructions furnished.

EXCEPT TO THE EXTENT PROVIDED BY LAW, NO IMPLIED WARRANTIES OR MERCHANTABILITY OR FITNESS FOR A PARTICULAR PURPOSE, AND NO IMPLIED WARRANTIES SHALL APPLY TO THE FIREPLACE AFTER THE ABOVE LIMITED WARRANTY HAS EXPIRED.

In states that do not allow limitations on how long implied warranty lasts, or do not allow exclusion of indirect damages, those limitations or exclusions may not apply to you. You may also have additional rights not covered in this limited warranty.

Gas Technologies, Inc. reserves the right to make changes at anytime, without notice, in design, material, specifications and prices and the right to discontinue styles and products.