

HEAT-N-GLO

No one builds a better fire

Hearth & Home Technologies Inc.
800 W. Jefferson
Lake City, MN 55041



This appliance has been retired.
Service parts pages within have been removed.
For replacement parts, please refer to the individual
service parts list located on the brand websites.

INSTALLATION & OPERATING INSTRUCTIONS

RHW-51 WOODBURNING FIREPLACE



Note: An arrow (➔) found in the text and in the index signifies change in content.

WARNING!

Improper installation, adjustment, alteration, service or maintenance can cause injury or property damage. Refer to this manual. For assistance or additional information, consult a qualified installer, service agency or the gas supplier.

TABLE OF CONTENTS

Design and Installation Considerations 3

A. Listings and Code Approvals 4

B. Description of the Fireplace System 4

C. System Components 5

D. Pre-Installation Preparation 9

E. Chimney Requirements 11

F. Installation of Fireplace 13

G. Constructing a Chase 20

H. Operating Instructions 22

I. Maintenance Instructions 26

Index 27

Warranty 28

CAUTION:

Do not expose the fireplace to the elements (i.e. rain, etc.) and keep the fireplace dry at all times. Wet insulation will produce an odor when the fireplace is used.

WARNING!

This appliance is tested and listed for use only with the optional accessories listed in these instructions. Use of optional accessories not specifically tested for this appliance could void the warranty and/or result in a safety hazard.

Safety Precautions

1. Please read these installation instructions completely before beginning installation procedures. Failure to follow them could cause a fireplace malfunction resulting in serious injury and/or property damage.
2. Always check your local building codes prior to installation. The installation must comply with all local, regional, state and national codes and regulations.
3. An adequate supply of replacement combustion air from outside the house must be available to the fire for the fireplace to operate properly. To achieve this, the use of the optional outside air kit is highly recommended.
In the event the home is unusually tightly sealed, the optional combustion air kit may not provide all the air required to support combustion. Hearth & Home Technologies is not responsible for any smoking or related problems that may result from the lack of adequate combustion air. It is the responsibility of the builder/contractor to ensure that adequate combustion air has been provided for the fireplace.
4. The fireplace must be installed with the Hearth & Home Technologies SL Series Chimney System.
The chimney system must always terminate outside the building. Be sure to follow all chimney specifications given in these installation instructions.
5. **NEVER** leave children unattended when there is a fire burning in the fireplace.
6. This fireplace is built for solid fuel only. **NEVER** use gasoline, gasoline type lantern fuel, kerosene, charcoal light fluid, or similar liquids in this fireplace. Keep any flammable liquids a safe distance from the fireplace.
7. **DO NOT** use chimney cleaners or flame colorants in your fireplace.
8. The flue damper must be open at all times when the fireplace is in use.
9. While servicing this fireplace, always shut off any electricity or gas to the fireplace. This will prevent possible electric shock or burns. Also, make sure the fireplace is completely cooled before servicing.
10. To ensure a safe fireplace system and to prevent the build up of soot and creosote, inspect and clean the fireplace and chimney prior to use and periodically during the burning season. See "Maintenance Instructions" in this manual for cleaning instructions.

No one builds a better fire

DESIGN AND INSTALLATION CONSIDERATIONS

When selecting a location for your woodburning fireplace, it is important to evaluate a number of considerations. Modern construction techniques can create conditions that may not allow your chimney to draft properly. This may result in smoke spillage from your fireplace, as well as cause other combustion appliances to operate incorrectly.

Tightly sealed construction is important for energy efficiency. Unfortunately, a great deal of effort has been directed to tightening up sidewall construction, while considerably less attention has been paid to tightening upper portions of the warm air envelope (insulated ceilings). This has increased the "Stack Effect", a condition that increases the negative pressure generated by the structure. This negative pressure will directly affect the drafting performance of a fireplace chimney. To minimize the negative pressure generated by stack effect, make certain that all ductwork installed in the attic spaces is sealed airtight. Minimize the number of recessed light fixtures installed in the insulated ceiling, and use sealed recessed light fixtures. Finally, make certain the whole house fans and attic access panels are tightly sealed. These are important design considerations that must be observed during the design and construction stage of the home.

If you desire to put a fireplace in your basement, we recommend that you consider a direct vent gas fireplace. Basements always have a significant negative air pressure that causes the fireplace system to be more susceptible to smoke spillage and cold flue backdrafting. Since direct vent gas fireplaces are sealed, they are not affected by the negative pressure that exists in basements.

Finally, woodburning fireplaces perform best when their chimney (roof termination) is located on the upper half of the roof, especially when cathedral ceilings are present. Chimneys that are located on the lower half of the roof realize what is known as "lazy flue" and will not draft as well as a chimney that is located in the upper portion of the roof. The reason for this is that the stack effect generated by the overall height of the living spaces inside the house will exceed the draft generated by the chimney system. If you desire to place a woodburning fireplace in a location where the termination cap would be located on the lower half of a roof, such as on an outside wall at the base of a cathedral ceiling, we recommend that you consider using a direct vent gas fireplace. This will assure the homeowner a fireplace that operates correctly.

These properties do not affect just your woodburning factory-built fireplace. They can cause any woodburning fireplace as well as any conventionally vented (B-vent) gas appliance to operate improperly. Careful planning at this stage of your project will ensure satisfaction with the operation of your fireplace once it is completed.

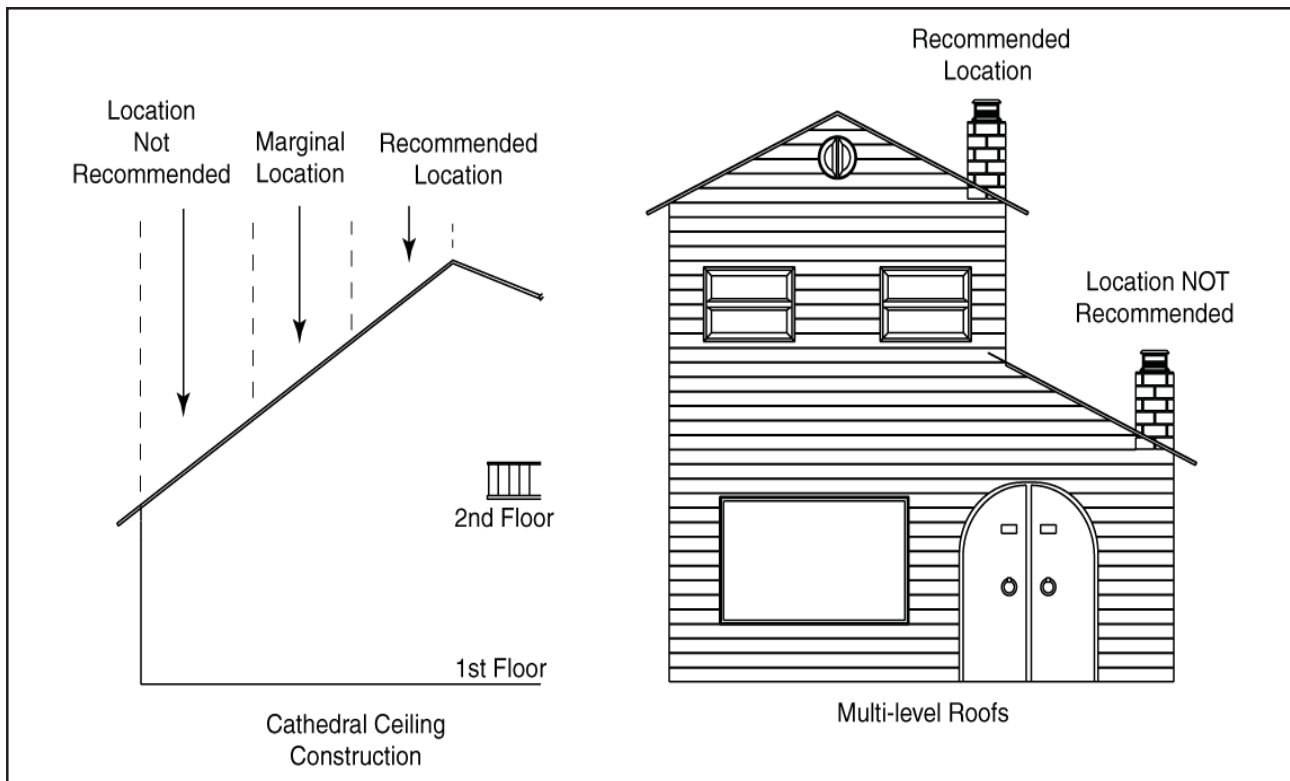

No one builds a better fire

No one builds a better fire

A. LISTINGS AND CODE APPROVALS

This fireplace system has been tested and listed in accordance with **UL 127** standards, and has been listed by Underwriters Laboratories Inc. for installation and operation in the United States as described in this manual.

This fireplace has been tested and listed for use with the optional components listed on page 5. These optional components may be purchased separately and installed at a later date. However, installation of an outside air kit will require significant reconstruction, and should be installed at the time of the initial fireplace installation.

Check with your local building code agency prior to installing

this fireplace to ensure compliance with local codes, including the need for permits and follow-up inspections. If you need assistance during installation, please contact your local dealer or the Heat-N-Glo Technical Services Department, 1-888-427-3973. ◀

Heat-N-Glo® is a registered trademark of Hearth & Home Technologies Inc., a Division of HON INDUSTRIES.

WARNING!

This fireplace and its components are designed to be installed and operated as a system. Any alteration to or substitution for items in this system, unless allowed by these installation instructions, will void the Underwriters Laboratories listing and may void the product warranty. It may also create a hazardous installation. Read through these instructions thoroughly before starting your installation and follow them carefully throughout your project.

B. DESCRIPTION OF THE FIREPLACE SYSTEM

1. The Heat-N-Glo fireplace system consists of the following:
 - a. Fireplace/Integral Grate/Outside Combustion Air System
 - b. Refractory
 - c. Chimney Termination Cap
 - d. Chimney System
 - e. Hearth Extension
2. Optional Components Include:
 - a. Glass Doors
 - b. Outside Combustion Air Kit

Note: Illustrations used throughout these instructions reflect "typical installations" and are for design purposes only. Actual installation may vary slightly due to individual design preferences. However, minimum and maximum clearances must be maintained at all times.

The illustrations and diagrams used throughout these installations instructions are not drawn to scale.

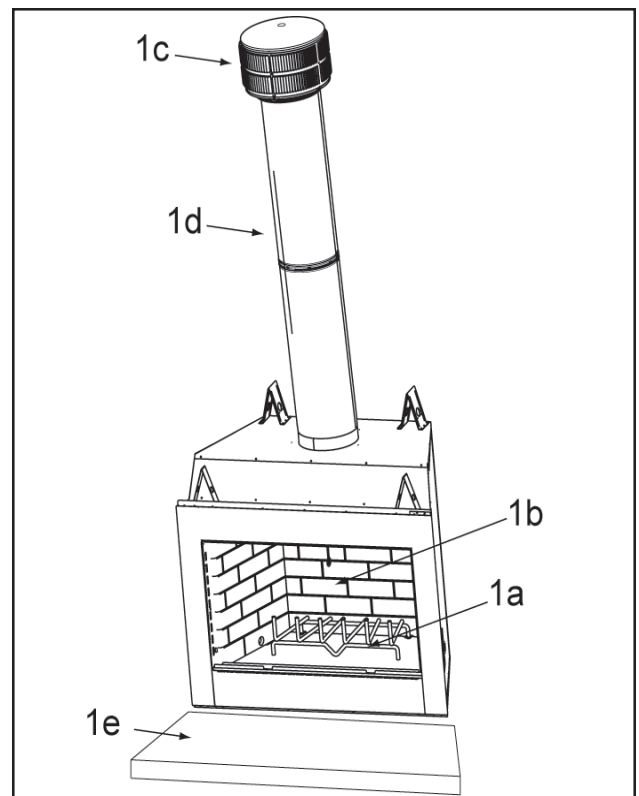
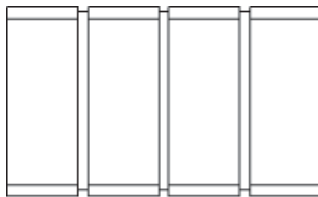

Figure 1 - Typical Fireplace System

C. SYSTEM COMPONENTS

1. Fireplace Components

Catalog #	Description:
RHW-51	Fireplace, with Integral Grate, Outside Air Kit and Hearth Protection Strips
DM1342	Glass Doors - Bi-fold, Clear-View - Black
DM1342B	Glass Doors - Bi-fold, Clear-View - Polished Brass
DM1342S	Glass Doors - Bi-fold, Clear-View - Stainless Steel
HX4	Hearth Extension
GR9	Integral Grate (included with Fireplace)



Bi-Fold Glass Doors

DM1342
DM1342B
DM1342S

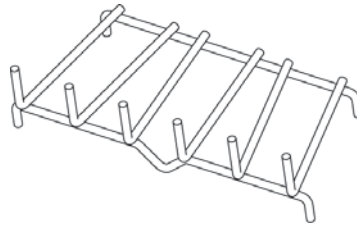

GR9 Integral Grate

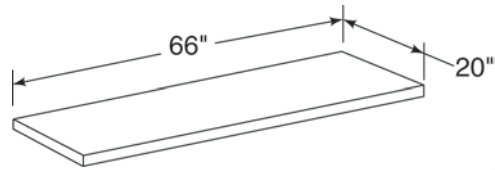

HX4 - Hearth Extension

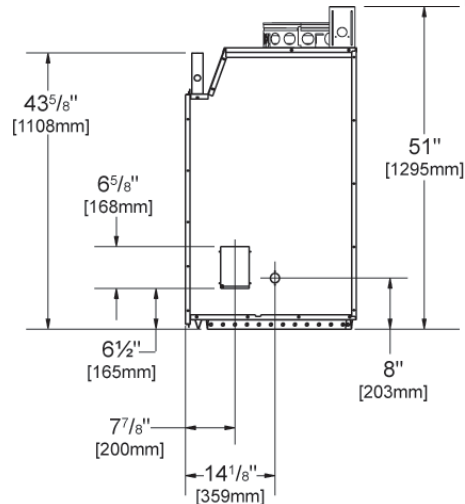
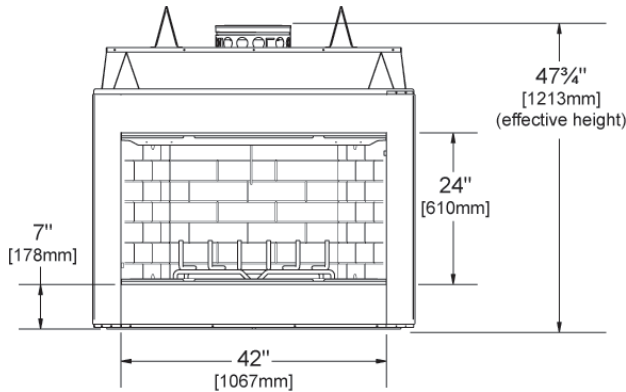
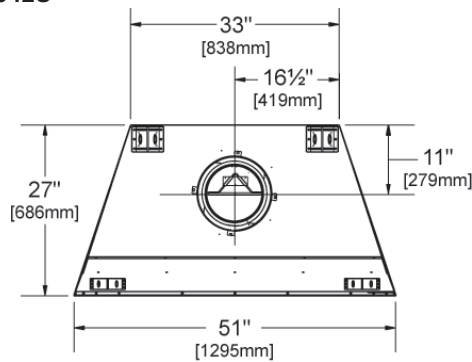

➔ Fireplace Dimensions

No one builds a better fire

No one builds a better fire

2. Chimney Components

The following pictures show only those chimney components which may be safely used with this fireplace.

Catalog #	Description:
AK14	Outside Air Kit (included with Fireplace)
CAK5A	Chimney Air Kit
ID4	Insulated Duct/Outside Air
UD4	Uninsulated Duct/Outside Air
SL1106	Chimney Section - 6" long
SL1112	Chimney Section - 12" long
SL1118	Chimney Section - 18" long
SL1136	Chimney Section - 36" long
SL1148	Chimney Section - 48" long
SL11	Chimney Stabilizer
SL1130	Chimney Offset/Return - 30°
FS538	Firestop - Straight
FS540	Firestop - 30°
AS10	Straight Attic Insulation Shield, 24"
JB577	Chimney Joint Band
CB576	Chimney Bracket
RF570	Roof Flashing - Flat to 6/12 Pitch
RF571	Roof Flashing - 6/12 to 12/12 Pitch
TR11	Round Termination Cap
TR11T	Round Telescoping Termination Cap
ST1175	Square Termination Cap
➔ TCT1175	Terra Cotta Termination Cap
CT56	Chase Top
LDS33	Decorative Shroud - 3' x 3'
LDS46	Decorative Shroud - 4' x 6'

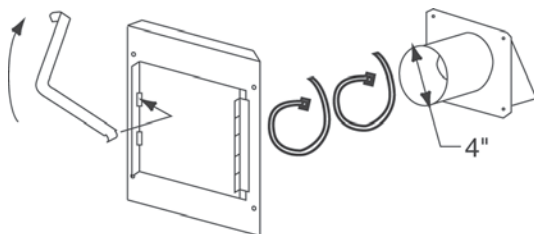

AK14 - Outside Air Kit

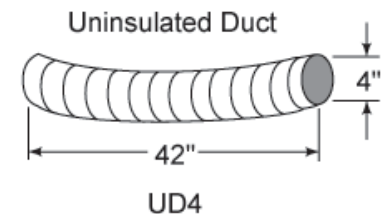
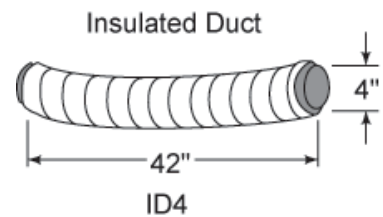

No one builds a better fire

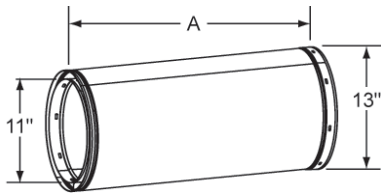

Chimney Sections

Catalog #	A	B
SL1106	6"	4 ³ / ₄ "
SL1112	12"	10 ³ / ₄ "
SL1118	18"	16 ³ / ₄ "
SL1136	36"	34 ³ / ₄ "
SL1148	48"	46 ³ / ₄ "

A = Actual length

B = Effective length (length of chimney part after it has been snapped to another)

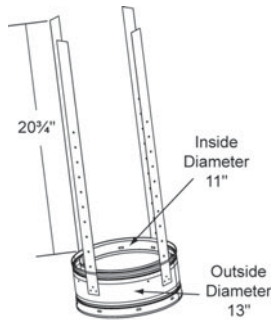

SL11 - Chimney Stabilizer

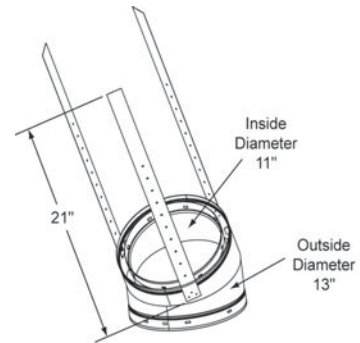

SL1130 - Offset/Return

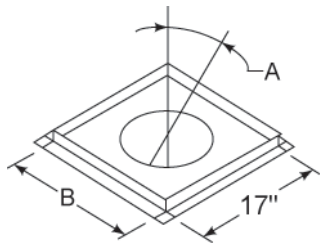

Firestop Spacer

Catalog #	A	B
FS538	0°	17"
FS540	30°	26"

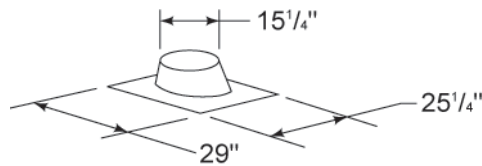

**RF570 - Roof Flashing
Flat to 6/12 Pitch**

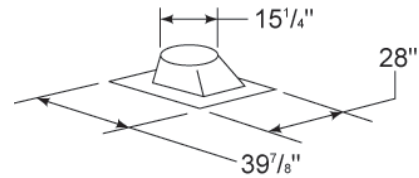

**RF571 - Roof Flashing
6/12 to 12/12 Pitch**

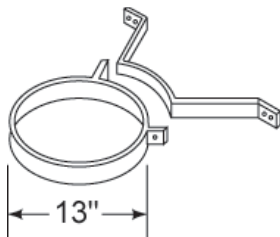

**CB576
Chimney Bracket**

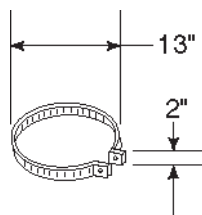

**JB577
Joint Band**



**AS10
Straight Attic
Insulation Shield**

No one builds a better fire

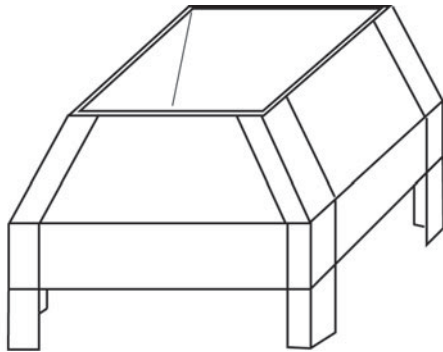

LDS33 (3' x 3')
LDS46 (4' x 6')
Decorative Shroud

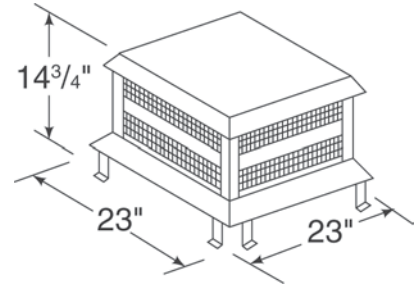

ST1175
Square
Termination Cap

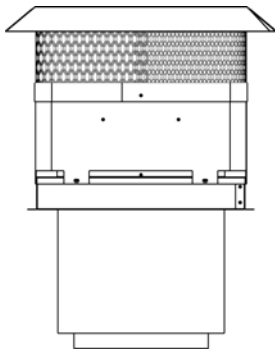

➡ **TCT1175**
Terra Cotta
Termination Cap

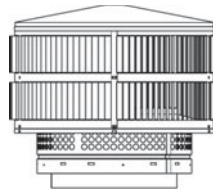

TR11
Round
Termination Cap

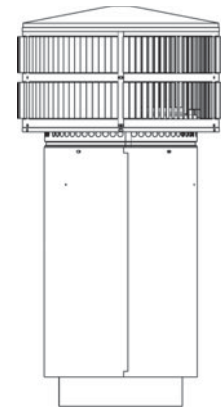

TR11T
Round Telescoping
Termination Cap

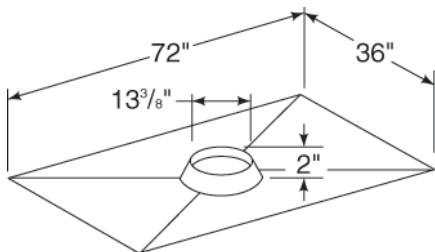

CT56
Chase Top

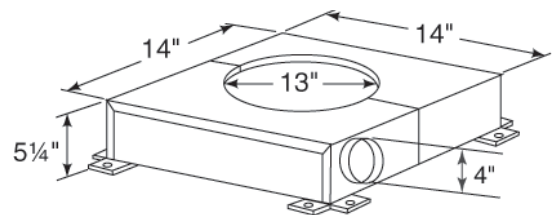

CAK5A
Chimney Air Kit

D. PRE-INSTALLATION PREPARATION

1. Fireplace Locations and Space Requirements

Several options are available to you when choosing a location for your fireplace. This fireplace may be used as a room divider, installed along a wall, across a corner or used in an exterior chase. See Figure 2.

Locating the fireplace in a basement, near frequently opened doors, central heat outlets or returns, or other locations of considerable air movement can affect the performance and cause intermittent smoke spillage from the front of the fireplace. Consideration should be given to these factors before deciding on a location.

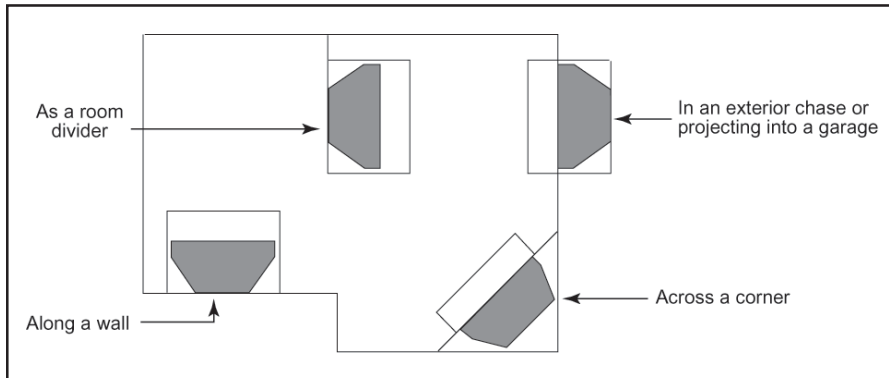

Figure 2 - Fireplace Locations

CLEARANCES!

A minimum $\frac{3}{4}$ " air clearance must be maintained at the back and sides of the fireplace assembly except at the nailing flange where the clearance is $\frac{1}{2}$ ".

Chimney sections at any level require a 2" minimum air space clearance between the framing and chimney section.

Figures 3 and 4 show two typical installations assuming an outside air kit is being used. Therefore, an allowance must be made for 90° bends. Less space is required when ducting goes directly outside without forming elbows.

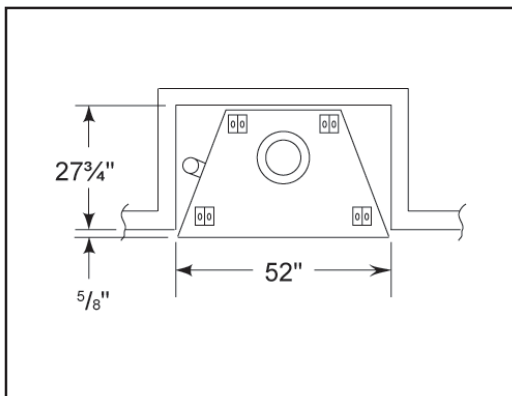

Figure 3
Installation Along a Wall or an Exterior Chase

These are rough framing dimensions only.

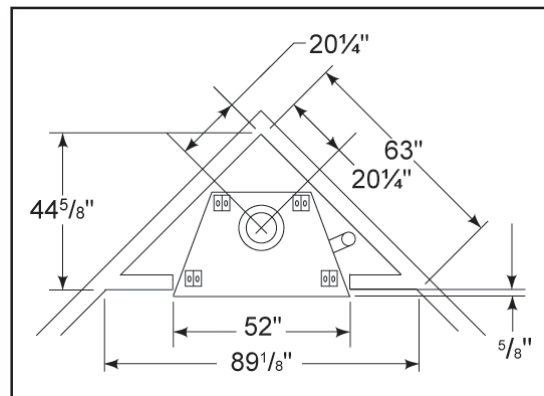

Figure 4
Corner Installation

WARNING!

Do not draw outside air from garage spaces. Exhaust products of gasoline engines are hazardous. Do not install outside air ducts such that the air may be drawn from attic spaces, basements or above the roofing where other heating appliances or fans and chimneys exhaust or utilize air. These precautions will reduce the possibility of fireplace smoking or air flow reversal.

WARNING!

To prevent contact with sagging or loose insulation, the fireplace must not be installed against vapor barriers or exposed insulation. Localized overheating could occur and a fire could result.

No one builds a better fire

No one builds a better fire

2. Frame the Fireplace

The RHW-51 fireplace will fit a framed opening of 52" wide x 43⁵/₈" tall. The finished cavity depth must be no less than 27³/₄".

Figure 5 shows a typical framing (using 2 x 4 lumber) of the fireplace, assuming combustible materials are used. All required clearances to combustibles around the fireplace must be adhered to. Any framing across the top of the fireplace must be above the level of the top standoffs. **Chimney sections at any level require a 2" minimum air space clearance between the framing and chimney section.**

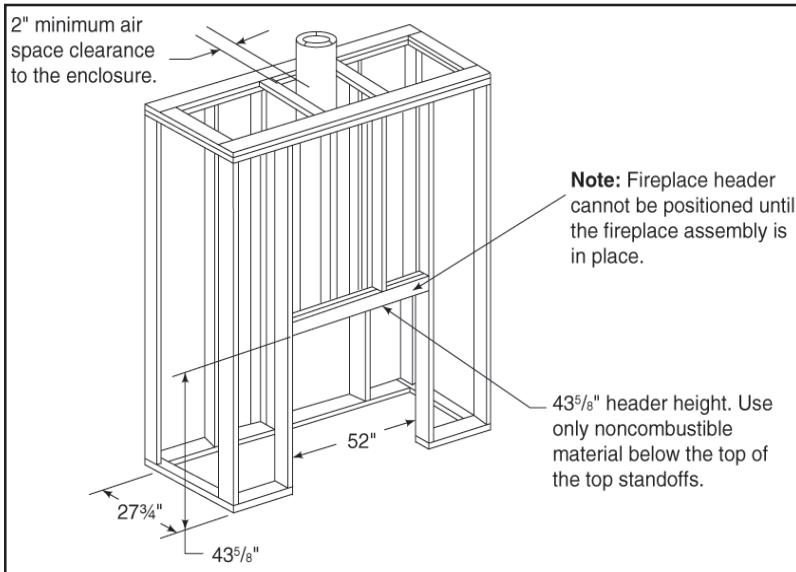

Figure 5 - Framing the Fireplace

CLEARANCES!

A minimum 3/4" air clearance must be maintained at the back and sides of the fireplace assembly except at the nailing flange where the clearance is 1/2".

Chimney sections at any level require a 2" minimum air space clearance between the framing and chimney section.

WARNING!

Do not apply combustible finishing materials over any part of the black face of this fireplace or a structure fire may result. The black metal fireplace front may only be covered with noncombustible materials such as ceramic tile, brick, or stone. Do not cover or block any cooling air slots. Do not cover any portion of the opening to the fireplace that would prevent the installation of an authorized glass door.

3. Sidewalls/Surrounds

Adjacent combustible side walls must be located a minimum of 24" from the fireplace opening. See Figure 6. If you are using a decorative surround constructed of combustible material, it must be located within the shaded area defined in Figure 6. Short stub walls are also acceptable if they are contained within the shaded area.

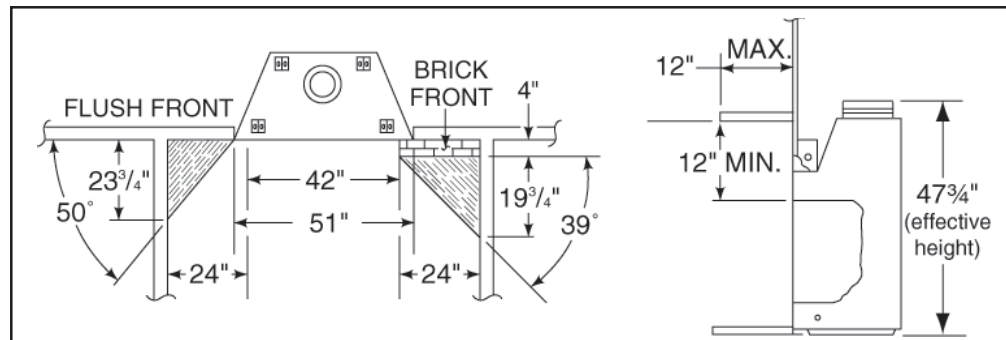

Figure 6 - Sidewalls and Surrounds

E. CHIMNEY REQUIREMENTS

When planning your fireplace location, the chimney construction and necessary clearances must be considered. The fireplace system and chimney components have been tested to provide flexibility in construction. The following figures are the minimum distances from the base of the fireplace.

- | | |
|---|----------|
| 1. Minimum overall straight height | 14.5 ft. |
| 2. Minimum height with offset/return | 18.5 ft. |
| 3. Maximum height | 90 ft. |
| 4. Maximum chimney length between an offset and return | 20 ft. |
| 5. Maximum distance between chimney stabilizers | 35 ft. |
| 6. Double offset/return minimum height | 24 ft. |
| 7. Maximum unsupported chimney length between the offset and return | 6 ft. |
| 8. Maximum straight unsupported chimney height above the fireplace | 35 ft. |

1. Using Offsets and Returns

- a. To bypass any overhead obstructions, the chimney may be offset using a 30° offset/return (SL1130). Perform the following steps to determine the correct chimney component combination for your particular installation.
- b. An offset and return may be attached together or a chimney section(s) may be used between an offset and return.
 - 1) Measure how far the chimney needs to be shifted to enable it to avoid the overhead obstacle. See Figure 7, dimension "A" to determine chimney sections required to achieve the needed shift.
 - 2) After determining the offset dimension, refer to Table 1 and find the "A" dimension closest to but not less than the distance of shift needed for your installation.
 - 3) The "B" dimension that coincides with the "A" dimension represents the required vertical clearance that is needed to complete the offset and return.
 - 4) Read across the chart and find the number of chimney sections required and the model number of those particular chimney parts.
 - 5) Whenever the chimney penetrates a floor/ceiling, a firestop spacer must be installed.
 - 6) The effective height of the fireplace assembly is measured from the base of fireplace to top of starter collar. See Figure 6.

Offset/Returns Table 1 30° Offset Chart

A	B	SL1106	SL1112	SL1118	SL1136	SL1148
3 ⁷ / ₈ "	14 ¹ / ₂ "	-	-	-	-	-
6 ¹ / ₄ "	18 ⁵ / ₈ "	1	-	-	-	-
9 ¹ / ₄ "	23 ³ / ₄ "	-	1	-	-	-
12 ¹ / ₄ "	29"	-	-	1	-	-
14 ⁵ / ₈ "	33"	-	2	-	-	-
17 ⁵ / ₈ "	38 ¹ / ₄ "	-	1	1	-	-
21 ¹ / ₄ "	44 ⁵ / ₈ "	-	-	-	1	-
23 ⁵ / ₈ "	48 ³ / ₄ "	1	-	-	1	-
27 ¹ / ₄ "	55 ³ / ₄ "	-	-	-	-	1
29 ⁵ / ₈ "	59"	1	-	-	-	1
32 ⁵ / ₈ "	64 ¹ / ₄ "	-	1	-	-	1
35 ⁵ / ₈ "	69 ¹ / ₂ "	-	-	1	-	1
38"	73 ⁵ / ₈ "	-	2	-	-	1
41"	78 ³ / ₄ "	-	1	1	-	1
44 ⁵ / ₈ "	85"	-	-	-	1	1
47"	89 ¹ / ₈ "	1	-	-	1	1
50 ⁵ / ₈ "	95 ¹ / ₂ "	-	-	-	-	2

WARNING!
Do not combine offsets to create an offset greater than 30° from vertical. This may create a fire hazard since the natural draft may be restricted.

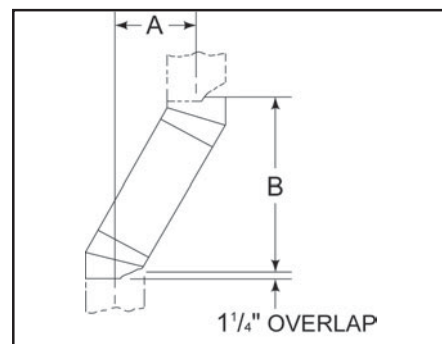

Figure 7 - Chimney Offset/Return

Example: Your "A" dimension from Figure 7 is 14¹/₂". Using Table 1 the dimension closest to, but not less than 14¹/₂" is 14⁵/₈" using a 30° offset/return. It is then determined from the table that you would need 33" (Dimension "B") between the offset and return. The chimney components that best fit your application are two SL1112s.

Proper assembly of air cooled chimney parts results in an overlap at chimney joints of 1¹/₄". Effective length is built into this table.

No one builds a better fire

No one builds a better fire

2. Chimney Height Requirements (above roof line)

- a. Major building codes specify a minimum chimney height above the roof top. These specifications are summarized in what is known as the *Ten Foot Rule*. This rule states:

“If the horizontal distance from the side of the chimney to the peak of the roof is ten feet or less, the top of the chimney must be at least two feet above the peak of the roof, but never less than three feet in overall height above the highest point where it passes through the roof.

“If the horizontal distance from the side of the chimney to the peak of the roof is more than ten feet, a chimney height reference point is established on the surface of the roof a distance of ten feet from the side of the chimney in a horizontal plane. The top of the chimney must be at least two feet above this reference point, but never less than three feet in height above the highest point where it passes through the roof.” See Figure 8.

- b. These chimney heights are necessary in the interest of safety but do not ensure smoke-free operation. Trees, buildings, adjoining roof lines, adverse wind conditions, etc. may create a need for a taller chimney should smoking occur.

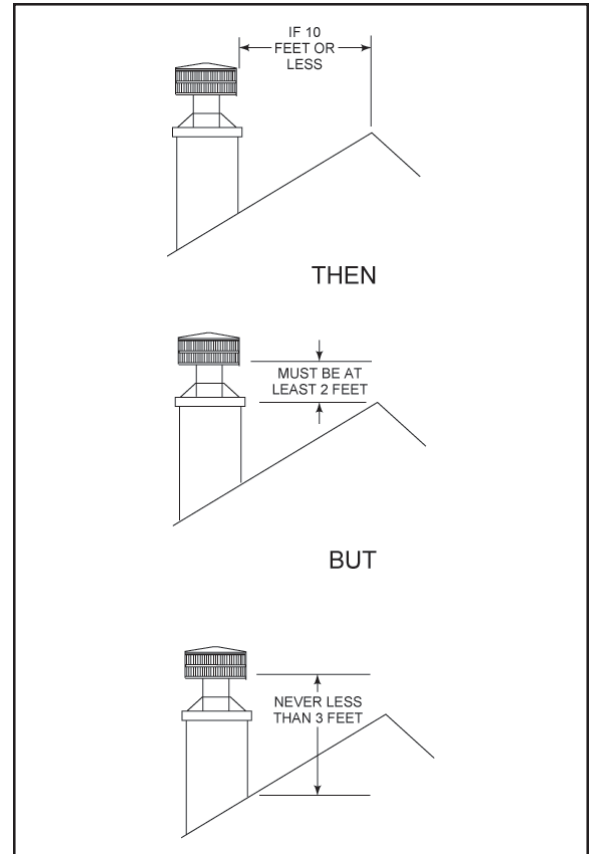

Figure 8 - Chimney Height

3. Number of Sections Required

To determine the chimney components needed to complete your particular installation, follow the steps below:

- a. Determine the total vertical height of the fireplace installation. This dimension is measured from the base of the fireplace assembly to the point where the smoke exits the termination cap.
- b. Subtract the effective height of the fireplace assembly from the overall height of the fireplace installation (measured from the base of the fireplace to the bottom of the termination cap).
- c. Refer to Table 2 to determine what components must be selected to complete the fireplace installation.
- d. Determine the number of firestop spacers, stabilizers, roof flashing, etc. required to complete the fireplace installation.

Table 2

HEIGHT OF CHIMNEY COMPONENTS	
Chimney Stabilizer	
SL11	4 ³ / ₄ "
Firestop Spacers	
FS538	0
FS540	0
Offsets/Returns	
SL1130	14 ¹ / ₂ "
Roof Flashing	
RF570	0
RF571	0
Chimney Sections*	
SL1106	4 ³ / ₄ "
SL1112	10 ³ / ₄ "
SL1118	16 ³ / ₄ "
SL1136	34 ³ / ₄ "
SL1148	46 ³ / ₄ "

*Dimensions reflect effective height.

F. INSTALLATION OF FIREPLACE

WARNING!

Before starting, do the following:

1. Wear gloves and safety glasses for protection.
2. Keep hand tools in good condition. Sharpen cutting edges and make sure tool handles are secure.
3. Always maintain the minimum air space required to the enclosure to prevent fire.

1. Position the Fireplace

This fireplace may be placed on either a combustible or noncombustible continuous flat surface. Follow the instructions for framing on pages 9 and 10. Slide the fireplace into position. **Be sure to provide the minimum air clearance at the sides and back of the fireplace assembly.**

2. Place the Protective Metal Hearth Strips

Included with your fireplace you will find two metal hearth strips measuring approximately 28" x 4". These strips are used to provide added protection where the fireplace and the hearth extension meet.

Slide each metal strip 2" under the front edge of the fireplace. The individual pieces must overlap each other by 1" minimum in the middle of the fireplace to provide continuous coverage of the floor. See Figure 9. These metal strips should extend from the front and sides of the fireplace opening by 2".

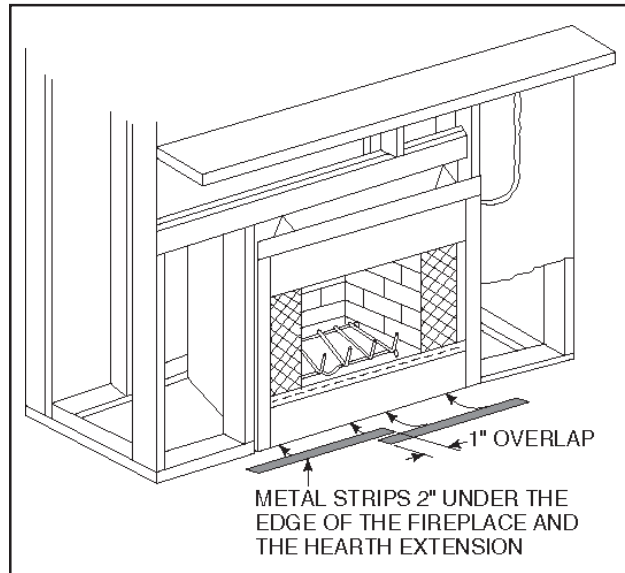

Figure 9 - Positioning the Metal Strips

3. Level the Fireplace

Level the fireplace side-to-side and front-to-back. Shim with noncombustible material, such as sheet metal, as necessary. Secure the fireplace (using the nailing flanges located on either side of the fireplace) to the vertical framing.

Important: To ensure proper fit of the glass doors, check the fireplace opening for square. Measure diagonal distances of the opening to make sure they are equal. If they are not equal, continue to shim the fireplace until those diagonals are equal.

No one builds a better fire

No one builds a better fire

4. Assemble Chimney Sections

Attach either a straight chimney section or an offset to the top of the fireplace (depending on your installation requirement). Chimney sections are locked together by pushing downward until the top section meets the stop bead on the lower section.

The inner flue is placed to the inside of the flue section below it. The outer casing is placed outside the outer casing of the chimney section below it. See Figure 10.

WARNING!

Carefully follow the instructions for assembly of the pipe and other parts needed to install this fireplace system. Failure to do so may result in a fire, especially if combustibles are too close to the fireplace or chimney and air spaces are blocked, preventing the free movement of cooling air.

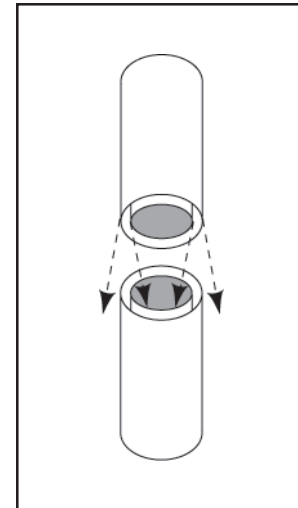

Figure 10
Assembling Chimney Sections

5. Install Firestop Spacers

Mark and cut out an opening in the ceiling for the firestop spacer being utilized (17" x 17" for an FS538, 17" x 26" for an FS540). Frame the opening with the same dimension lumber used in the ceiling joists.

Install the firestop spacer.

These firestop spacers are designed to provide the minimum 2" air space required around the chimney. In all situations, the firestop spacers are to be nailed to the ceiling joists from the bottom or fireplace side, **EXCEPT** when the space above is an insulated ceiling or attic space. In this situation, the firestop spacer **must** be nailed from the top side to prevent loose insulation from falling into the required 2" air space around the chimney. See Figure 11.

CAUTION:

Firestop spacers must be used whenever the chimney penetrates a ceiling/floor area.

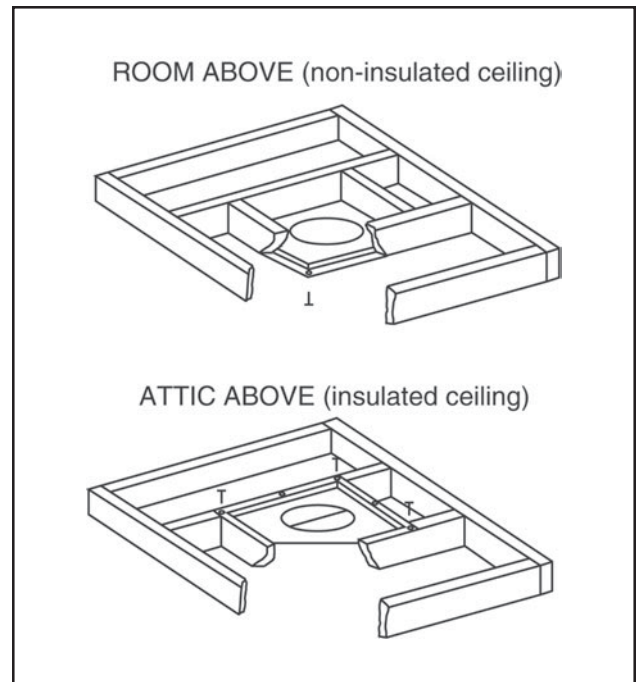

Figure 11
Installing the Firestop Spacer

➔ **6. Attic Insulation Shield**

An insulation shield should be installed when there is a possibility of insulation coming into contact with the factory built chimney system.

- a. Bend the tabs at the top of the attic insulation shield inward. This will help keep the chimney section centered in the shield.
- b. Position the shield over the vertical chimney section where it penetrates a firestop spacer.
- c. Slide the shield down until it rests on the firestop spacer. The firestop spacer will support the insulation shield. See Figure 12.

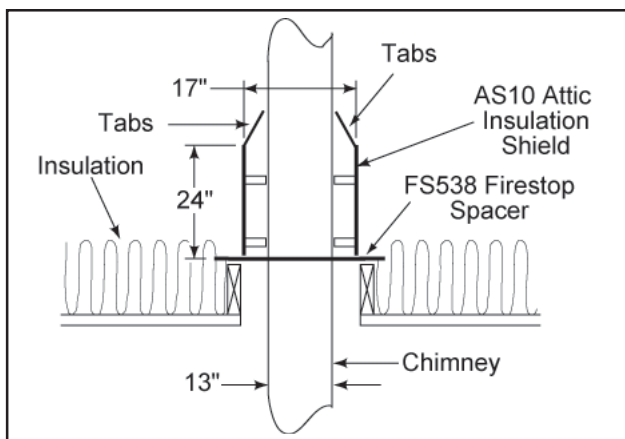

Figure 12 - Installing an Insulation Shield

8. Secure the Chimney System

When offsets and returns are joined to straight pipe sections, they must be locked into position with the screws provided (outer only), using the predrilled holes. To prevent gravity from pulling the chimney sections apart, the returns and the chimney stabilizers have straps for securing these parts to joists or rafters. See Figure 13.

Note: You must provide support for the pipe during construction and check to be sure inadvertent loading has not dislodged the chimney section from the fireplace or at any chimney joint.

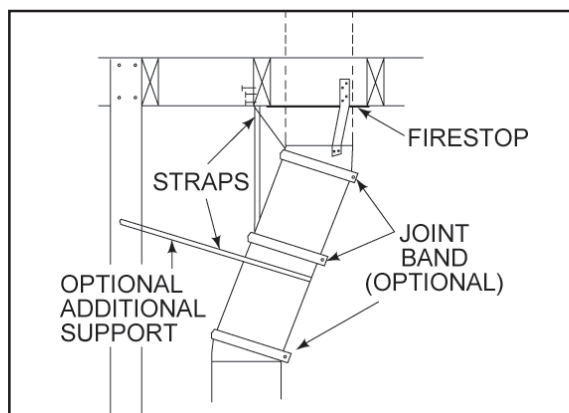

Figure 13 - Offset/Return with Stabilizer

➔ **WARNING! RISK OF FIRE.**
Do not fill the space between the chimney section and the insulation shield with insulation.

WARNING!
When chimney sections exceeding six feet in length are installed between an offset and return, structural support must be provided to reduce off-center loading and prevent chimney sections from separating at the chimney joints.

7. Double-check the Chimney Assembly

Continue assembling the chimney sections up through the firestop spacers as needed. While doing so, be aware of the height and unsupported chimney length limitations that are given on page 11 under "Chimney Requirements".

Check each section by pulling up slightly from the top to ensure proper engagement before installing the succeeding sections. If they have been connected correctly, they will not disengage when tested.

WARNING!
Maintain a minimum of 2" air clearance to all parts of the chimney system at all times! Failure to maintain this 2" air clearance will cause a structure fire.

CAUTION:
Inner flue and outer liner sections cannot be disassembled once locked together. Plan ahead to ensure the proper installation height is achieved with the selected chimney components.

No one builds a better fire

No one builds a better fire

9. Mark the Exit Point of the Roof

Locate the point where the chimney will exit the roof by plumbing down to the center of the chimney. Drive a nail up through the roof to mark the center. See Figure 14.

10. Cut out the Hole in the Roof

Measure to either side of the nail and mark the 17" x 17" or 17" x 26" opening required. This is measured on the horizontal; actual length may be larger depending on the pitch of the roof. Cut out and frame the opening. See **Chapter 25 of the Uniform Building Code** for roof framing details.

Be sure to maintain a 2" minimum air space between the chimney section and the roof.

11. Assemble the Chimney Sections Through the Roof

Continue to add chimney sections through the roof opening, maintaining at least a 2" air space.

12. Install the Roof Flashing

If a roof flashing is to be used, install the roof flashing appropriate to the roof pitch and install a round termination cap following the instructions shipped with the cap.

For chase installations you can use a round termination cap (TR11), a round telescoping termination cap (TR11T) or a square termination cap (ST1175). A chase installation must use a chase top. Chase tops are available from your Heat-N-Glo distributor. See page 20 for building a chase.

13. Install the Outside Air Kit

The outside air kit is supplied as a standard feature with this fireplace and its use is highly recommended to minimize the effects of negative pressure within the structure. It is recommended to utilize the shortest duct run to optimize the performance of the outside air kit. The outside air kit inlet thimble should be positioned at least four feet above the ground level, in a manner that will not allow snow, leaves, etc. to block the inlet.

The outside air kit is installed on the left hand side of the fireplace. Remove the cover plate from the side of the fireplace assembly where the air kit is to be installed. See Figure 15 for handle location/operation.

14. Install the Chimney Air Kit

When installing the chimney air kit, follow the instructions provided with this accessory.

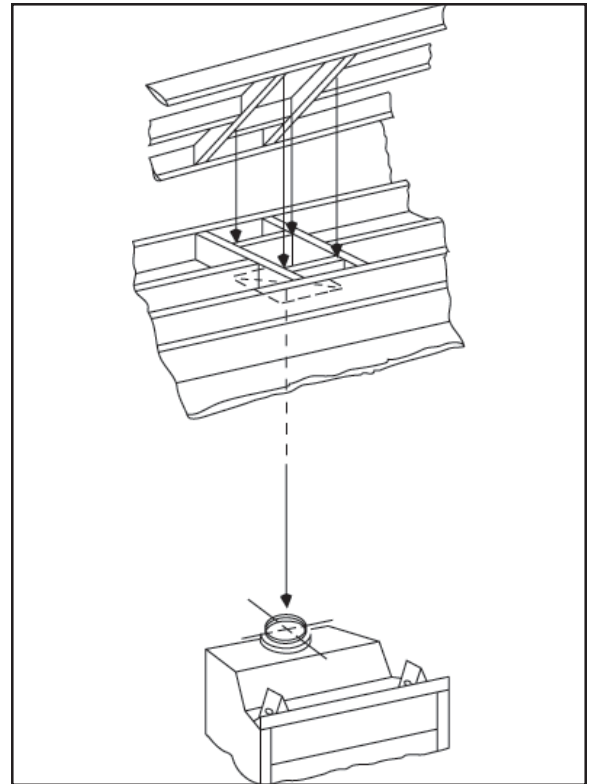

Figure 14 - Ceiling/Attic Construction

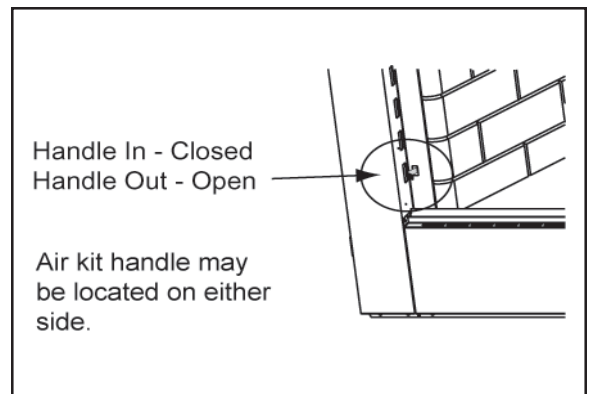

Figure 15 - Air Kit Handle Location

CAUTION:
The air kit handle may get hot while burning the fireplace. Use care when operating the handle.

15. Complete the Enclosure

Complete the fireplace enclosure, allowing space for outside air ducts and gas piping if desired. Electrical wiring should not come in contact with the fireplace. **A minimum clearance of 3/4" must be maintained between the fireplace sides and the enclosure as well as the fireplace back and the enclosure.** See pages 9 and 10 for framing details.

Note: Use only a noncombustible material to finish the face of the fireplace below the level of the front standoffs. A noncombustible material such as USG MICORE CV230 Mineral Fiber Board, or USG DUROCK Cement Board is recommended for this purpose.

CAUTION:

When using a gas log set, the fireplace damper must be set in the fully open position. This ensures proper venting of combustion products.

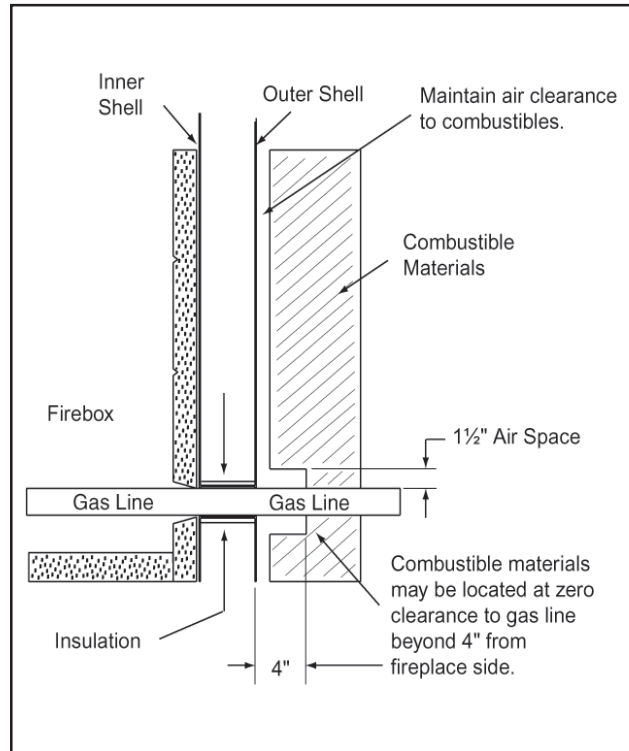

Figure 16 - Air Clearance Around Gas Line

16. Gas Log/Lighter Provisions

Knockouts are provided on both sides of the fireplace to allow for connection of a certified gas log lighter or a decorative gas appliance with a maximum input of 100,000 BTU/hour, incorporating an automatic gas shutoff device and complying with the **Standard for Decorative Gas Appliances for Installation in Vented Fireplaces, ANSI Z21.60**. The decorative gas appliance should be installed in accordance with the **National Fuel Gas Code, ANSI Z223.1-1980**. The side refractories are designed to allow 1/2" iron pipe to pass through. Use a noncombustible sealant to seal any opening between the gas pipe and refractory on the inside. Repack the insulation removed to seal around the gas pipe where it exits the side of the fireplace. A minimum 1 1/2" air clearance must be provided around the 1/2" iron pipe for a minimum of 4 inches beyond the fireplace. See Figure 16.

WARNING!

This fireplace was not tested by the fireplace manufacturer for use with an unvented gas log heater. To reduce risk of injury, do not install an unvented gas log heater in this fireplace unless it has been specifically tested and listed by Underwriter's Laboratories Inc. for use in this specific model fireplace. Unless the unvented gas log heater is tested and listed for use in this factory built fireplace, a fire hazard may be created that can result in a structure fire.

CLEARANCES!

A minimum 3/4" air clearance must be maintained at the back and sides of the fireplace assembly except at the nailing flange where the clearance is 1/2". Chimney sections at any level require a 2" minimum air space clearance between the framing and chimney section.

No one builds a better fire

No one builds a better fire

17. Hearth Extension

A hearth extension must be installed with all fireplaces to protect the combustible floor in front of the fireplace from both radiant heat and sparks.

The construction of, and materials used for a hearth extension are shown in Figures 17 and 18. A hearth extension of this construction may be covered with any noncombustible decorative material and may have a maximum thickness as per the illustration. Seal gaps between the hearth extension and the front of the fireplace with a bead of noncombustible sealant.

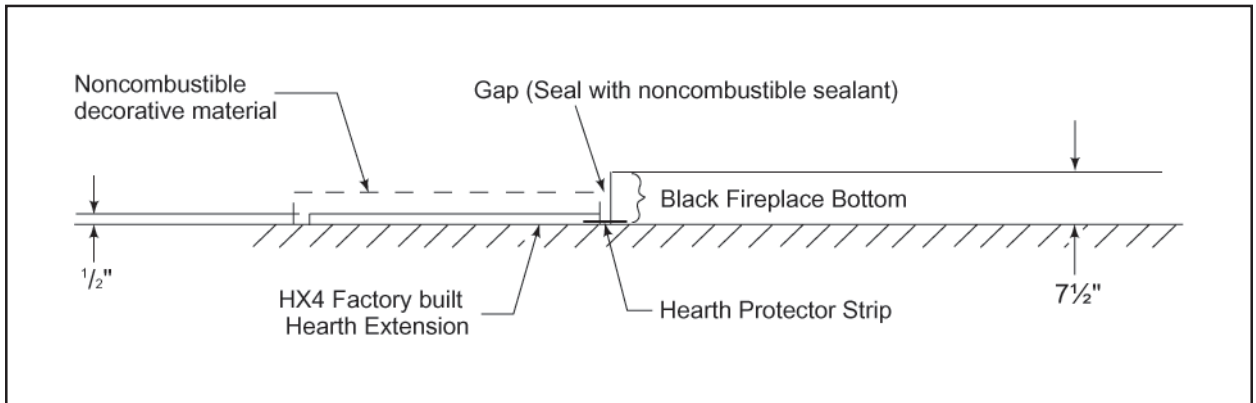

Figure 17 - Factory Built Hearth Extension

Field constructed hearth extensions should be constructed in accordance with the instructions in Figure 18. The field constructed hearth extension must be constructed from 1/2" MICORE CV230, or a material with an equivalent insulation value.

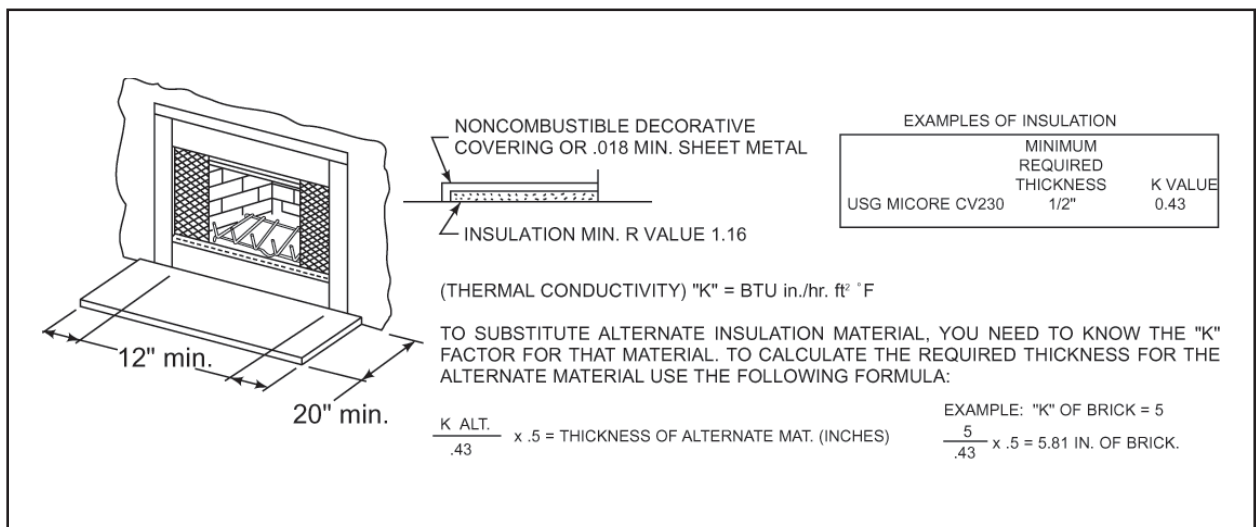

Figure 18 - Field Constructed Hearth Extension

WARNING!

Hearth extensions are to be installed only as illustrated to prevent high temperatures from occurring on concealed combustible materials. Hearth sealing strips prevent burning or hot particles from inadvertently falling directly on combustible surfaces in the event the building should settle and disturb the original construction.

18. Position the Hearth Extension

Position and secure the hearth extension over the protective metal strips that have been placed partially under the fireplace front. These strips should be protruding approximately 2" from under the fireplace front and 2" on both sides of the fireplace opening. **Seal the crack between the hearth extension and fireplace with a bead of noncombustible sealant.** See Figure 19. Apply a noncombustible finishing material of your choice to the hearth extension.

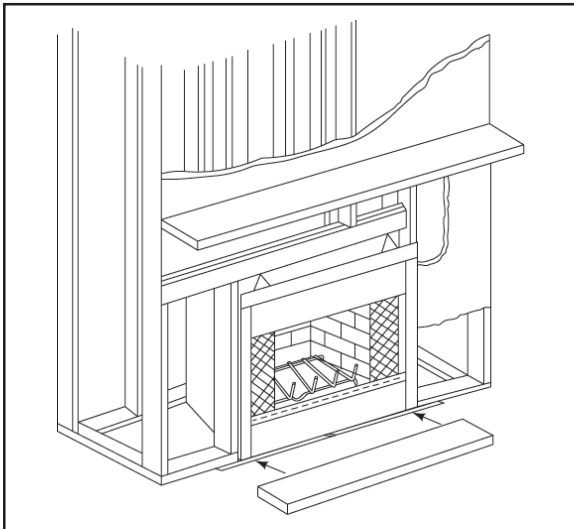

Figure 19 - Position the Hearth Extension

19. Finishing Material

Do not install combustible materials over the black face of the fireplace! This poses a safety hazard and may start a fire. **You may only use noncombustible material over the black face of the fireplace.**

a. Combustible Material

Material which is made of or surfaced with wood, compressed paper, plant fibers, plastics, or any material capable of igniting and burning, whether flame proofed or not, plastered or unplastered.

b. Noncombustible Material

Material which will not ignite and burn. Such materials are those consisting entirely of steel, iron, brick, tile, concrete, slate, glass or plasters, or any combination thereof.

c. Noncombustible Sealant Material

Sealants which will not ignite and burn; General Electric RTV103 Black (or equivalent), Rutland, Inc. Fireplace Mortar #63 (or equivalent).

After completing the framing and applying the facing material (dry wall) over the framing, a ½" wide (maximum) bead of noncombustible sealant must be used to close off any gaps at the top and sides between the fireplace and facing to prevent cold air leaks.

Only noncombustible materials may be used to cover the black metal fireplace front.

20. Mantel

A combustible mantel may be positioned no lower than 12" above the top of the fireplace opening. The combustible mantel may have a maximum depth of 12". Combustible trim pieces that project no more than 1½" from the face of the fireplace can be placed no closer than 6" from the top of the fireplace opening. Combustible trim must not cover the black metal surfaces of the fireplace. This mantel clearance is in accordance with **Section 7-3.3.3 of ANSI/NFPA211.**

21. Glass Doors

This fireplace has been tested and listed for use with doors as specified in Section "C. System Components". Please refer to the manual packed with each set of doors for installation instructions.

No one builds a better fire

G. CONSTRUCTING A CHASE

A chase is a vertical boxlike enclosure built around the chimney and fireplace. A chase may be constructed for the fireplace and chimney or for the chimney only. It is most commonly constructed on an outside wall.

In cold climates, it is recommended that the chase floor be insulated using batt type insulation between the floor joists.

Three examples of chase applications are shown in Figure 20.

1. Fireplace and chimney enclosed in an exterior chase.
2. Chimney offset through exterior wall and enclosed in chase.
3. Chase constructed on roof.

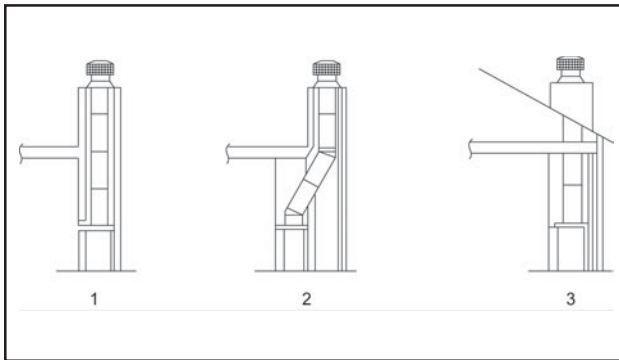

Figure 20 - Chase Constructions

1. Materials

- a. The chase is constructed using framing materials much the same as the walls in your home. A variety of materials may be used including brick, stone, veneer brick, or standard siding materials.
- b. In constructing the chase, several factors must be considered:
 - 1) Maintain a 2" air space around the chimney.
 - 2) The chase top must be constructed of noncombustible material.
 - 3) In cold climates, a firestop spacer should be installed in an insulated false ceiling at the 8' level above the fireplace assembly. This reduces heat loss through the chase.
 - 4) In cold climates, the walls of the chase should be insulated to the level of the false ceiling as shown in Figure 21. This will help reduce heat loss from the home around the fireplace.

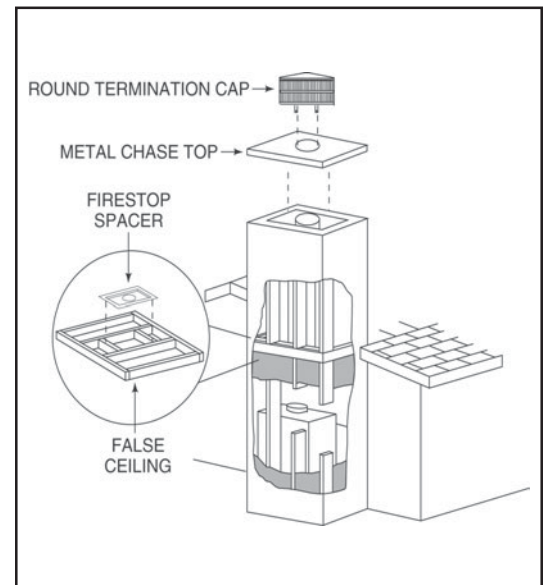

Figure 21 - Chase Assembly

No one builds a better fire

2. Chase Top

Construct a chase of desired materials maintaining a minimum 2" air space around the chimney.

3. Termination Cap

- a. Install the chimney sections up through the chase enclosure. When using a TR11 round termination cap, the uppermost top section of pipe must extend 6" above the top of the chase collar to allow installation of the storm collar and termination cap. See Figure 22.
- b. For installations utilizing a TR11T telescoping round termination cap, the uppermost chimney section must be below the top of the chase top, but not more than 14½" below the top of the chase top flashing collar. See Figure 23.
- c. For installations utilizing an ST1175 square termination cap the last chimney section must not be more than 4½" below the chase top. See Figure 24.
- d. Attach the chase top to the top of the chase.
- e. Install the termination cap, following the instructions provided with it.

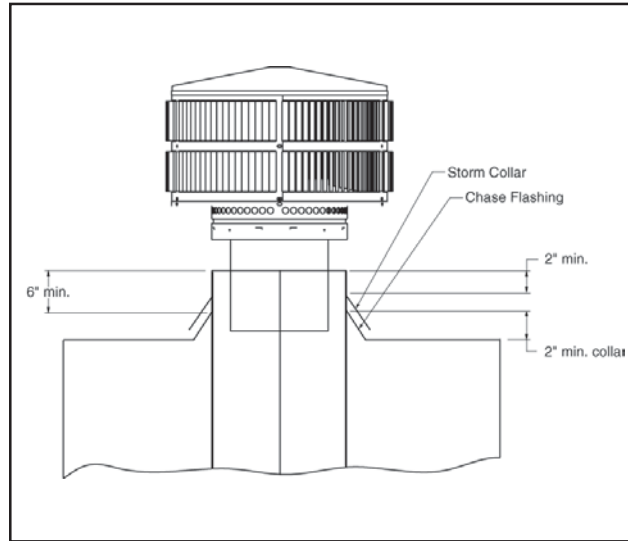

Figure 22 - Installing a TR11 Round Termination Cap

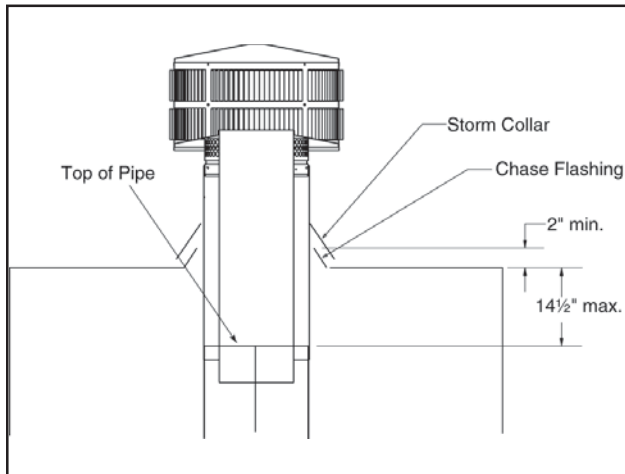

Figure 23 - Installing a TR11T Round Telescoping Termination Cap

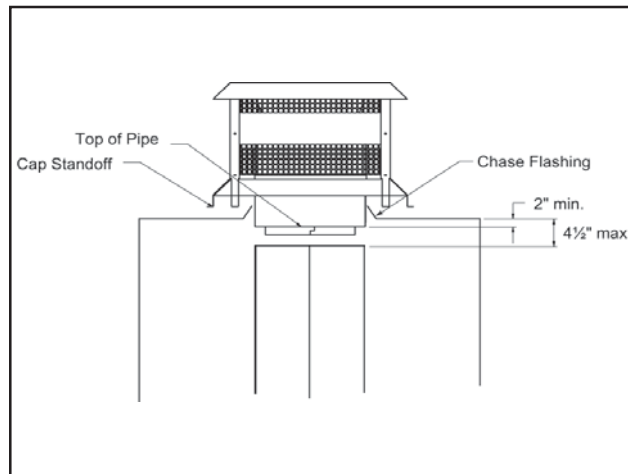

Figure 24 - Installing an ST1175 Square Termination Cap

WARNING!

Never install a single wall slip section or smoke-pipe in a chase structure. The higher temperature of this single wall pipe may radiate sufficient heat to combustible chase materials to cause a fire.

WARNING!

Detailed instructions for installation of the chase top, storm collar and termination cap are packaged with these parts. To avoid danger of fire, all instructions must be strictly followed, including the provision of air space clearance between chimney system and enclosure. To protect against the effects of corrosion on those parts exposed to the weather, we recommend that the chase top and termination cap be painted with a rust-resistant paint.

No one builds a better fire

H. OPERATING INSTRUCTIONS

Note: Save and pass this instruction manual to subsequent home owners. The information provided is intended to notify and warn them about making unsafe future modifications such as the addition of shelves or the use of unauthorized parts and repairs.

1. General Information

This fireplace is intended to operate as a supplemental heat source for a single room. It is not designed to function as a primary heat source for a structure.

Fireplaces, as well as other woodburning appliances, have been used safely for many years. It has been our experience that most problems are caused by improper installation and operation of the fireplace. Make certain that installation and operation of the fireplace system is in accordance with these instructions.

It is extremely important that the fire be supervised whenever the fireplace is in use. It is also recommended that an annual inspection be performed on the fireplace system to determine if the flue system needs to be cleaned, or as in the case of any appliance, if minor repairs are required to maintain the system in top operating condition.

This factory built fireplace is intended for use with either solid fuel (firewood) or a decorative gas appliance that has been tested and listed to the **Standard for Decorative Gas Appliances for Installation in Vented Fireplaces, ANSI Z21.60**. When operating your fireplace, the flue damper must be in the open position.

This fireplace was not tested and listed for use with an unvented gas log heater. Do not install an unvented gas log heater in this fireplace and operate it with the flue damper in the closed position unless the unvented gas log heater has been specifically tested and listed for use in this fireplace by Underwriters Laboratories Inc.

Use of an unvented gas log heater in this factory built fireplace may create a fire hazard that can result in a structure fire.

WARNING!

DO NOT operate this fireplace with the flue damper in the closed position. Combustion products must vent up the chimney system to prevent carbon monoxide poisoning, and to prevent hot combustion gases from contacting and overheating combustible surfaces. Failure to operate this fireplace with the damper in the open position may result in asphyxiation or a structure fire.

2. Outside Air

A source of air (oxygen) is required in order for combustion to take place. Whatever air is consumed by the fire must be replaced through cracks around windows, under doors, etc. Most newly constructed houses or existing homes fitted with tightly sealed doors and windows are relatively air tight. In this case, an outside air source must be made available to feed combustion air from outside the home.

A damper control handle allows you control of the outside air inlet if your fireplace is equipped with this option. Use of outside air for combustion is highly recommended to conserve heated air within the structure and to provide make up air to keep the fireplace venting properly.

This fireplace will operate correctly only if adequate ventilation is provided to allow proper draft to the fireplace system. Hearth & Home Technologies assumes no responsibility for the improper performance of the fireplace system caused by inadequate draft due to environmental conditions, down drafts, tight sealing construction of the structure, or mechanical exhausting devices which create a negative air pressure within the structure where the fireplace is located.

CAUTION:

Fireplace operation does require air. Do not take air from other fuel burning appliances which can result in improper venting (smoking) or air dilution. Always provide adequate makeup air.

3. Flue Damper

The flue damper must be in a full open position, and is operated by moving the handle up toward the top of the fireplace. Before lighting the fire, verify this by looking up from the inside of the fireplace. Always operate this fireplace with the damper fully open. Please note: down drafts, obstructions, damaged or poor (wet) fuels can cause smoke spillage.

4. Glass Doors

Most efficient fireplace operation using glass doors is with the doors open. When the doors are open, the screen must be closed. Only Hearth & Home Technologies glass doors may be used. See Figure 25 for proper glass door operation.

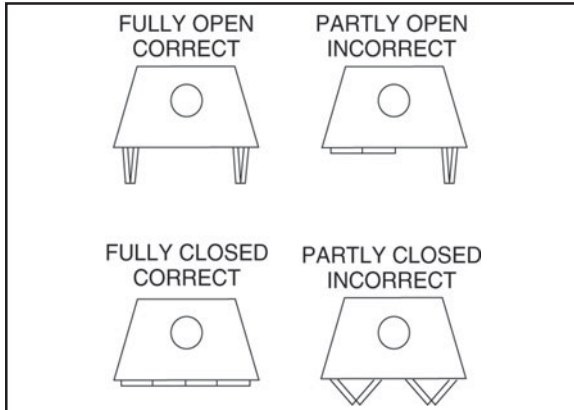

Figure 25
Proper Operating Positions of Bi-Fold Doors

5. Grate

The factory installed integral grate must be used to hold the logs from falling out of an open fireplace and to allow air to pass between the burning logs. It is important to keep the fire off the hearth and to allow the ashes to collect beneath the fire, thereby forming a layer of additional heat protection.

6. Firescreen

A firescreen is always provided to control sparks. It must be closed whenever the fireplace is in use. Glass doors or firescreens must not be used to hold burning material inside the fireplace. Only those glass doors specifically tested and listed for use with the specific fireplace model should be used. Screens should be closed when the glass doors are closed.

CAUTION:
When left closed while burning your fireplace, firescreens and glass doors will be HOT. Handle with care!

WARNING!
Do not store fuel within the clearances to combustibles, or in the space required for refueling and ash removal. See maintenance instructions, "Clear Space Near the Fireplace".

7. Wood Fuel

FIREWOOD: Your fireplace performance depends on the quality of the firewood you use. All seasoned wood, regardless of species, contains about 8,000 BTU's per pound, and hardwoods have a greater density than soft woods. A piece of hardwood will contain about 60% more BTU's than an equal size piece of soft wood. Firewood is commonly sold by the cord (128 cu. ft.). A cord of seasoned oak (hardwood) would contain about 60% more potential energy than a cord of seasoned pine (soft wood).

Soft woods are generally considered coniferous. These are trees with needle-like leaves that stay green all year and carry their seeds exposed in a cone. Examples of soft wood trees are Douglas fir, pine, spruce, and cedar. Soft woods require less time to dry, burn faster and are easier to ignite than hardwoods.

Hardwoods are generally considered deciduous. Deciduous trees are broadleaf trees that lose their leaves in the fall. Their seeds are usually found within a protective pod or enclosure. Some examples are oak, maple, apple, and birch. It should be noted that there are some deciduous trees that are not considered hardwoods, such as poplar, aspen, and alder. Hardwoods require more time to season, burn slower and are usually harder to ignite than soft woods.

The best wood fuel is a combination of soft wood and hardwood. Start the fire with soft wood; the fire will give off quick heat to bring the fireplace up to operating temperature, and then the hardwood can be added for slow, even heat and longer burn time.

MOISTURE: Regardless of which species of wood you burn, the single most important factor that effects the way your fireplace operates is the amount of moisture in the wood. The majority of the problems fireplace owners experience are caused by trying to burn wet, unseasoned wood.

Freshly cut wood can be as much water as it is wood, having a moisture content of around 50%. Imagine a wooden bucket that weighs about eight pounds. Fill it with a gallon of water, put it in the fireplace and try to burn it. This sounds ridiculous but that is exactly what you are doing if you burn unseasoned wood.

WARNING!
Burning wet, unseasoned wood can cause excessive creosote accumulation. When ignited it can cause a chimney fire that may result in a serious house fire.

No one builds a better fire

No one builds a better fire

SEASONING: Seasoned firewood is nothing more than wood that is cut to size, split and air dried to a moisture content of around 20%. The time it takes to season wood varies from around nine months for soft woods to as long as eighteen months for hardwoods. The key to seasoning wood is to be sure it has been split, exposing the wet interior and increasing the surface area of each piece. A tree that was cut down a year ago and not split is likely to have almost as high a moisture content now as it did when it was cut.

The following guideline will ensure properly seasoned wood:

- a. Stack the wood to allow air to circulate freely around and through the woodpile.
- b. Elevate the woodpile off the ground to allow air circulation underneath.
- c. The smaller the pieces, the faster the drying process. Any piece over six inches in diameter should be split.
- d. Cover the top of the woodpile for protection from rain and snow. Avoid covering the sides and ends completely. Doing so may trap moisture from the ground and impede air circulation.

The problems with burning wet, unseasoned wood are twofold: First, you will receive less heat output from wet wood because it requires energy in the form of heat to evaporate the water trapped inside. This is wasted energy that should be used for heating your home. Secondly, this moisture evaporates in the form of steam which has a cooling effect in your fireplace and chimney system. When combined with tar and other organic vapors from burning wood it will form creosote which condenses in the relatively cool fireplace and chimney.

8. Starting a Fire

Check the flue damper to be certain it is in the full open position. Place crumpled or twisted paper under the fireplace grate. Loosely arrange kindling or small pieces of wood to form a layer above the paper.

The fires must be built on the fireplace grate, without danger of the burning fuel falling out of the fireplace opening.

Light the paper and add small pieces of wood until a hot bed of embers has been established.

After establishing the fire bed, and the small firewood is burning briskly, add a minimum of three average sized pieces of split firewood, place the wood in such a manner to allow combustion air and flames between them.

Note: The first three or four fires should be of moderate size to allow the oils and binders to be burned from the fireplace and the refractory and paint to cure. You may notice an industrial odor the first few fires. This is considered normal.

As you use the fireplace, expansion and contraction will cause minor cracking of the refractory. This is normal, unavoidable, and will not affect the performance of the fireplace. If the cracks become large enough that the metal behind the refractory is exposed or large pieces fall out, the panels should be replaced.

CAUTION:

Never use gasoline, gasoline-type lantern fuel, kerosene, charcoal lighter fluid, or similar liquids to start or "freshen up" a fire in this fireplace. Keep all such liquids well away from the fireplace.

WARNING!

Fireplaces equipped with doors should be operated only with the doors fully open or fully closed. If doors are left partially open, gas and flame may be drawn out of the fireplace opening, creating the risk of both fire and smoke.

9. Draft Problems

Note: When first lighting your fireplace, it may be necessary to pre-warm the flue to establish a draft. This is done by holding a rolled up piece of burning newspaper under the flue damper for a few moments. This will help reduce smoke spillage during start-up.

This fireplace will operate correctly only if adequate ventilation is provided to allow proper draft to the fireplace system. Hearth & Home Technologies assumes no responsibility for the improper performance of the fireplace system caused by inadequate draft due to environmental conditions, down drafts, tight sealing construction of the structure, or mechanical exhausting devices which will create a negative air pressure within the structure where the fireplace is located.

Flue draft is measured as negative pressure in the chimney. The amount of negative pressure determines how strong the draft is. The draft is important because it draws the combustion air into the fireplace and pulls the smoke out of the chimney.

There are three basic criteria essential in establishing and maintaining flue draft:

- Availability of combustion air.
- Heat generated from the fire.
- Diameter and height of the flue system.

These three factors work together as a system to create the flue draft. Increasing or decreasing any one of them will affect the other two and thus change the amount of draft in the entire system. See Figure 26.

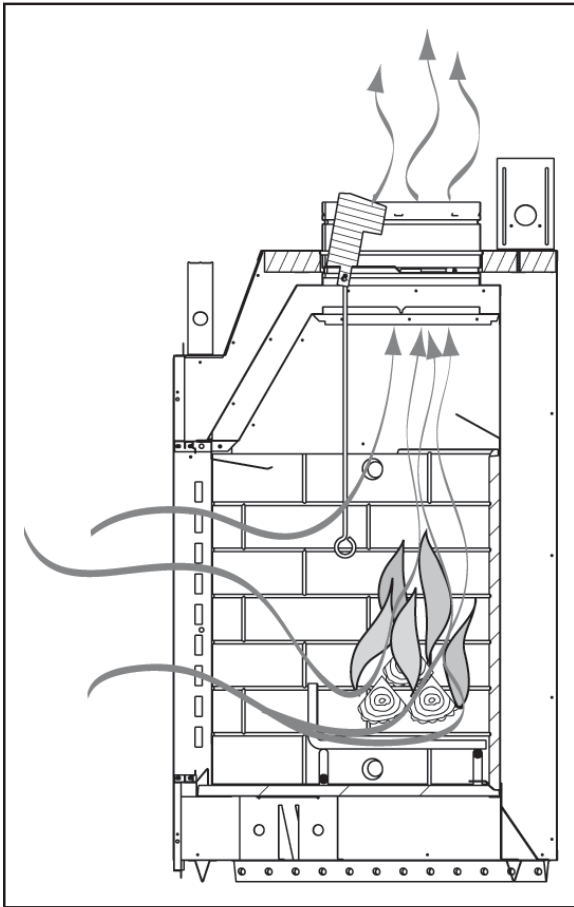

Figure 26 - Flue Draft

If the fire is hard to start and smoke spills out of the fireplace, or you find it difficult to establish and maintain a moderately high burn rate, then the flue draft is too low and corrective measures must be taken.

Be sure you have air available for combustion and that your firewood is dry and well seasoned. Build your fires properly and according to the instructions given in operating instructions, "Starting a Fire". Be sure your flue system is installed correctly and that it is the proper diameter and height. Check for the following:

- All chimney sections are properly installed and the joints are tightly sealed.
- The chimney is clean and free of creosote buildup.
- Make sure overhanging trees and branches are cut back within ten feet of the top of the chimney.
- Ensure the chimney cap is clean and free of any buildup of soot or creosote.

If you still suspect you have a low draft problem it may be necessary to increase the volume of air in your flue system. Since the diameter of your flue system is matched with the size of the flue collar and should not be changed, then the height of the system must be increased. Add chimney sections a little at a time until the draft improves.

In some cases, regardless of what you do, it can still be difficult to establish the proper flue draft. This is especially evident when using an exterior factory built chimney or exterior masonry chimney. Try placing several sheets of crumpled paper on top of your kindling as close to the flue outlet of the fireplace as possible. Light this paper first then the paper under the kindling.

The heat generated from the rapidly burning paper on top of the kindling should help get the draft established. Still other factors can affect how well your flue system performs. Neighboring structures, high winds, tall trees, even hillsides can affect air currents around the chimney. Well designed chimney caps are available that can help. Your fireplace dealer is the local expert in your area. He or she can usually make suggestions or discover problems that can be easily corrected allowing your fireplace to operate correctly as it has been designed, providing safe and economical heat for your home.

No one builds a better fire

I. MAINTENANCE INSTRUCTIONS

1. Disposal of Ashes

Ashes should be placed in a metal container with a tight-fitting lid. The closed container of ashes should be placed on a noncombustible floor or on the ground, well away from all combustible materials, pending final disposal. If the ashes are disposed of by burial in soil or otherwise locally dispersed, they should be retained in the closed container until all embers have thoroughly cooled.

2. Creosote and Soot

Inspect the chimney internally for obstructions and construction damage. Flue pipe joints and seams must be continuous and mechanical tight. In a used chimney, additional inspection is needed for creosote buildup, which is the formation of a flammable sediment.

When wood is burned slowly, it produces tar and other organic vapors, which combine with expelled moisture to form creosote. The creosote vapors condense in the relatively cool chimney flue of a slow-burning fire. As a result, creosote residue accumulates on the flue lining. When ignited, this creosote makes an extremely hot fire.

The chimney should be inspected at least twice a year during the heating season to determine if creosote buildup has occurred.

If creosote has accumulated, it should be removed to reduce the risk of a chimney fire.

WARNING!

A chimney fire can permanently damage your chimney system. This damage can only be repaired by replacing the damaged component parts. Chimney fires are not covered by the Limited Warranty and Buyer Protection Plan.

3. Chimney Cleaning

If you do detect a buildup of creosote, contact a qualified chimney sweep or clean it yourself. To do this, perform the following steps:

- a. Open the damper.
- b. Hang a damp sheet across the fireplace opening to stop dirt and soot from entering the room.
- c. Remove the termination cap or housing top.
See Figure 27.
- d. Clean with a stiff nylon brush attached to a pole OR tie a small burlap bag filled with straw and several small stones or sand. Work up and down the flue until the flue is clean.
- e. Replace the termination cap or housing top.

4. Clear Space Near the Fireplace

Combustible materials must not be stored on the hearth extension. Room furnishings such as drapes, curtains, chairs, or other combustibles must be at least four feet from the open front of the fireplace.

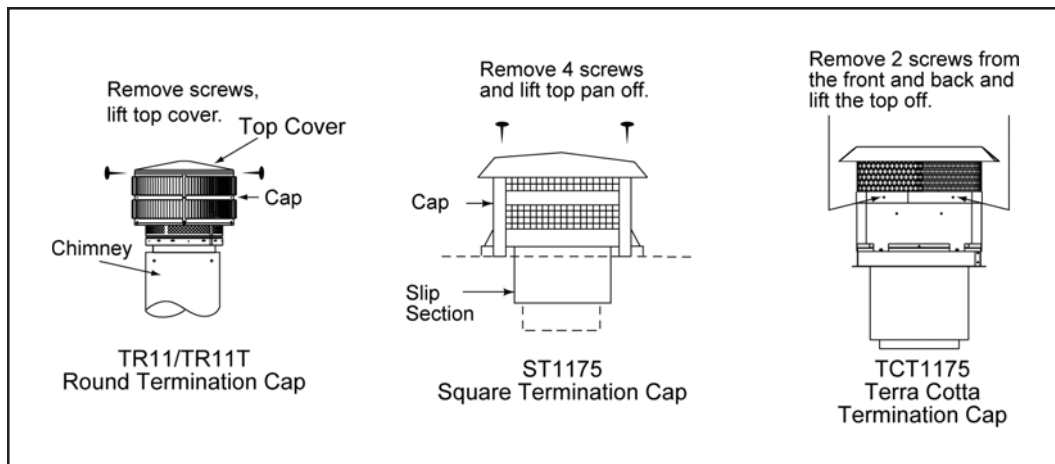

Figure 27
➔ **Chimney & Termination Cap Cleaning**

No one builds a better fire

Index

A

Air Clearance 15, 17
 Air Clearances 9, 10, 17
 Air Kit 6, 16
 Ashes, Disposal of 26
 ➔ Attic Insulation Shield 15

B

Building Codes 4, 16, 19

C

Chase 20
 Chase Installation 9
 Chase Top 8, 21
 Chimney
 Assembling Sections Through the Roof 16
 Checking the Assembly 15
 Cleaning 26
 Creosote 26
 Exit Point Through the Roof 16
 Height Requirements 12
 Requirements 11
 Securing the System 15
 Chimney Air Kit 8, 16
 Chimney Bracket 7
 ➔ Chimney Components 6
 Chimney Requirements 11
 Chimney Sections
 Assembling 14
 Number Required 12
 Chimney Stabilizer 7
 Cleaning
 Disposal of Ashes 26
 Clearances 9, 10, 17
 Codes
 Building 4, 16, 19
 Gas 17, 22
 Combustible
 Material 18
 Combustible Material 19
 Components 5
 Construction 18
 Corner Installation 9
 Creosote 26

D

Damper 22
 Description of the Fireplace System 4
 Dimensions 5
 Doors 5, 19, 23
 Draft 24

E

Exhaust Products 9

F

Fireplace
 Enclosure 17
 Locations 9
 Firescreen 23
 Firestop Spacer 7
 Installation 14
 Flue 22
 Flue Damper 22
 Framing 9, 10
 Fuel 23

G

Gas Codes 17, 22
 Gas Log/Lighter Provisions 17
 General Information 22
 Glass Doors 5, 19
 Operation 23
 Grate 5, 23

H

Hearth Extension 5, 18
 Positioning 19

I

Installation
 Fireplace 13
 In a Chase 9
 In a Corner 9
 In a Wall 9
 Insulation Shield 7, 15

J

Joint Band 7

L

Leveling the Fireplace 13
 ➔ Listings and Code Approvals 4
 Locations 9

M

Maintenance 26
 Mantel 10, 19
 Material, Sealant 19
 Metal Hearth Strips 13
 Moisture Content of Wood 23

N

Negative Air Pressure 24
 Noncombustible Material 19
 Noncombustible Sealant Material 19

O

Offsets>Returns 7, 11
 Outside Air 22
 Outside Air Kit 6, 16
 Overhead Obstructions 11

P

Positioning 13

R

Roof Flashing 7, 16

S

Safety 13
 Seasoning the Wood 24
 Shroud 8
 Sidewalls/Surrounds 10
 Smoke 9
 Soot 26
 Space Requirements 9
 Standard for Decorative Gas Appliances 17, 22
 Starting a Fire 24

T

Ten Foot Rule 12
 Termination Cap 8, 21
 Typical Fireplace System 4

U

UL 127 Standards 4
 Uniform Building Code for Roof Framing
 Details 16
 Unvented Gas Log Heater 17, 22

V

Ventilation 24

W

Wall Installation 9
 Wet Insulation 2
 Wood
 Moisture of 23
 Seasoning of 24
 Wood Fuel 23

No one builds a better fire



WARRANTY FOR HEAT-N-GLO FIREPLACES

The limited warranty will not become effective until you have mailed the completed warranty card to:
Hearth & Home Technologies Inc., A DIVISION OF HON Industries
20802 Kensington Blvd., Lakeville, MN 55044.

This card must be mailed within 60 days of the fireplace installation.

Subject to the conditions set forth herein, HEARTH & HOME TECHNOLOGIES INC. (HHT) extends the following limited warranty with respect to your Heat-N-Glo fireplace, excluding accessories, chimney components and glass doors.

If HHT is satisfied that any part or portion of the fireplace covered by this warranty is defective in material or workmanship under normal use and service as described in the operating instructions, HHT will take the following actions:

1. Within the first five (5) years from the date of installation, HHT shall, at its option, replace or repair any such defect in material or workmanship, at HHT's expense. HHT SHALL NOT BE RESPONSIBLE FOR ANY OTHER LABOR COSTS, OR EXPENSES, INCLUDING INDIRECT, INCIDENTAL OR CONSEQUENTIAL DAMAGES.
2. During the sixth (6th) through the (10th) years after the date of installation, HHT shall supply replacement parts or parts at no charge, but SHALL NOT BE RESPONSIBLE FOR ANY LABOR, TRANSPORTATION, OR OTHER INDIRECT DAMAGES.
3. During the eleventh (11th) through the fifteenth (15th) years after date of installation, HHT will send to you, FOB its factory, replacement parts (if available) at the current minimum wholesale price, but HHT SHALL NOT BE RESPONSIBLE FOR ANY LABOR, TRANSPORTATION OR OTHER INDIRECT DAMAGES.
4. During the first six (6) months after installation, HHT shall, at its option, replace or repair the glass doors and any electrical components, if operation is faulty. (This does not include glass panels broken during shipment, misuse or careless handling.) After the first six (6) months, HHT will sell to you, FOB its factory, replacement parts at the current list price, but HHT SHALL NOT BE RESPONSIBLE FOR ANY LABOR, TRANSPORTATION OR OTHER INDIRECT DAMAGES. IF GLASS DOORS OTHER THAN FACTORY DOORS ARE USED ALL WARRANTY AND LIABILITY ON THE FIREPLACE IS VOIDED.

HHT may discharge its entire warranty liability by refunding the price of the product.

Products made by other manufacturers, sold with the fireplace or thereafter are not covered by this limited warranty.

This limited warranty will be void if the fireplace is not installed according to the installation instructions. The limited warranty also is void if the fireplace is not operated, at all times, according to the operating instructions furnished. The limited warranty will also be void if the fireplace is removed from the place originally installed.

EXCEPT TO THE EXTENT PROVIDED BY LAW, NO IMPLIED WARRANTIES OF MERCHANTABILITY OR FITNESS FOR A PARTICULAR PURPOSE, AND NO IMPLIED WARRANTIES SHALL APPLY TO THE FIREPLACE AFTER THE ABOVE LIMITED WARRANTY HAS EXPIRED.

In states that do not allow limitations on how long implied warranty lasts, or do not allow exclusion of indirect damages, those limitations or exclusions may not apply to you. You may also have additional rights not covered in this limited warranty.

HHT reserves the right to make changes at anytime, without notice, in design, material, specifications and prices and the right to discontinue styles and products.

• UNDERWRITERS LABORATORIES FILE NO. MH5850

Jan 2003