

**Models:**  
**BAY-40, PIER-40**  
**Multi-Sided**  
**Wood Burning Fireplace**

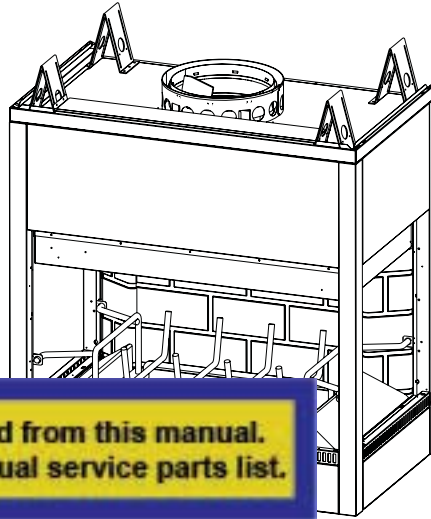

BAY-40 Shown



**Service parts list has been removed from this manual. Refer to Owner's Manual or individual service parts list.**

### NOTICE



#### DO NOT DISCARD THIS MANUAL

- Important operating and maintenance instructions included.
- Read, understand and follow these instructions for safe installation and operation.
- Leave this manual with party responsible for use and operation.



### ⚠ WARNING



**If the information in these instructions is not followed exactly, a fire may result causing property damage, personal injury, or death.**

- Do not store or use gasoline or other flammable vapors and liquids in the vicinity of this or any other appliance.
- Do not overfire. Overfiring will void your warranty.
- Comply with all minimum clearances to combustibles as specified. Failure to comply may cause house fire.

### ⚠ WARNING



#### HOT SURFACES!

Screen/mesh, glass doors and other surfaces are hot during operation AND cool down.

#### Hot screen/mesh and glass doors will cause burns.

- **DO NOT** touch screen/mesh or glass doors until cooled
- NEVER allow children to touch screen/mesh or glass doors
- Keep children away
- CAREFULLY SUPERVISE children in same room as fireplace.
- Alert children and adults to hazards of high temperatures.

#### High temperatures may ignite clothing or other flammable materials.

- Keep clothing, furniture, draperies and other flammable materials away.

### ⚠ WARNING



#### Fire Risk

- For use with solid wood fuel or decorative gas appliance only.
- **DO NOT** install unvented gas logs.



Installation and service of this fireplace should be performed by qualified personnel. Hearth & Home Technologies suggests NFI certified or factory-trained professionals, or technicians supervised by an NFI certified professional.



**Read this manual before installing or operating this fireplace.  
Please retain this owner's manual for future reference.**

**Congratulations!**

Congratulations on selecting a Heat & Glo wood burning fireplace. The Heat & Glo fireplace you have selected is designed to provide the utmost in safety, reliability and efficiency.

As the owner of a new fireplace, you'll want to read and carefully follow all of the instructions contained in this owner's manual. Pay special attention to all cautions and warnings.

This owner's manual should be retained for future reference. We suggest you keep it with your other important documents and product manuals.

The information contained in this owner's manual unless noted otherwise, applies to all models and gas control systems.

Your new Heat & Glo wood burning fireplace will give you years of durable use and trouble-free enjoyment. Welcome to the Heat & Glo family of fireplace products!

<b>Homeowner Reference Information</b>	<i>We recommend that you record the following pertinent information about your fireplace:</i>
Model Name: _____	Date purchased/installed: _____
Serial Number: _____	Location on fireplace: _____
Dealership purchased from: _____	Dealer phone: _____
Notes: _____	
_____	
_____	

**Listing Label Information/Location**

The model information regarding your specific fireplace can be found on the rating plate located on the smoke shield of the fireplace.

Serial Number
Grate
Fireplace Model

	<b>FIREPLACE NO.</b> [ ]	<small>WARNING: RISK OF FIRE DAMAGE. REPLACE GRATE WITH HEARTH &amp; HOME TECHNOLOGIES INC.</small>	<b>MODEL NO.</b> [ ]	<b>MODEL NO.</b> [ ]	<b>MFG. DATE</b> [ ]
<small>FIRECHAMBER INTENDED FOR USE WITH HEARTH &amp; HOME TECHNOLOGIES INC. LISTED FIREPLACE PARTS. SEE INSTALLATION AND OPERATING INSTRUCTIONS FOR THIS MODEL. ONLY HEARTH &amp; HOME TECHNOLOGIES INC. GLASS DOOR KITS CAN BE INSTALLED ON THIS UNIT.</small>					
<small>FIREPLACE ALSO FOR USE IN MANUFACTURED HOMES</small>		YES <input type="checkbox"/> NO <input type="checkbox"/>	<small>CLEARANCE TO COMBUSTIBLES:</small>	CHIMNEY 2 IN. MIN. FIREBOX [ ]	IN. MIN. [ ]
		<small>FAN KIT MODEL NO.</small> [ ] & [ ]	<small>RATED AT 115 VOLTS, 50/60 Hz.,</small> [ ] <small>AMP.</small>		
<small>DO NOT OVERFIRE. USE ONLY: SOLID WOOD FUEL OR LISTED DECORATIVE GAS APPLIANCE. DO NOT USE A FIREPLACE INSERT OR OTHER PRODUCTS NOT SPECIFIED FOR USE WITH THIS PRODUCT. IF DOORS ARE USED OPERATE FIREPLACE WITH DOORS FULLY OPEN OR CLOSED ONLY. WHEN BURNING A DECORATIVE GAS APPLIANCE IN THE FIREPLACE, ADJUST DAMPER TO THE FULLY OPEN POSITION.</small>			<small>WARNING! THIS FIREPLACE HAS NOT BEEN TESTED WITH AN UNVENTED GAS LOG SET. TO REDUCE THE RISK OF FIRE OR INJURY, DO NOT INSTALL AN UNVENTED GAS LOG SET INTO FIREPLACE.</small>		
			<small>WARNING! THIS APPLIANCE IS NOT FOR USE AS COOKING EQUIPMENT.</small>		
<small>IF INSTALLATION OR OPERATING INSTRUCTIONS ARE MISSING CONTACT: HEARTH &amp; HOME TECHNOLOGIES INC., 1915 W. SAUNDERS ST., MT. PLEASANT, IA 52641.</small>					

**Note:** An arrow (➔) found in the text signifies change in content.

## Safety Alert Key:

- **DANGER!** Indicates a hazardous situation which, if not avoided will result in death or serious injury.
- **WARNING!** Indicates a hazardous situation which, if not avoided could result in death or serious injury.
- **CAUTION!** Indicates a hazardous situation which, if not avoided, could result in minor or moderate injury.
- **NOTICE:** Indicates practices which may cause damage to the fireplace or to property.

## Table of Contents

Congratulations!	2	<b>7 Installation of Fireplace</b>	<b>21</b>		
Warranty	4	A. Things to Consider	21		
<b>1 Listing and Code Approvals</b>	<b>6</b>	B. Position the Fireplace	21		
A. Appliance Certification	6	C. Place Protective Metal Hearth Strips	21		
B. Non-Combustible Materials	6	D. Level Fireplace	21		
C. Combustible Materials	6	E. Install Outside Air Kit	23		
<b>User Guide</b>					
<b>2 Operating Instructions</b>	<b>7</b>	<b>8 Chimney Assembly</b>	<b>24</b>		
A. Your Fireplace	7	A. Chimney Requirements	25		
B. Seasoned Wood	8	B. Using Offsets>Returns	26		
C. Starting a Fire	8	C. Assemble Chimney Sections	27		
D. Grate	8	D. Install Chimney Air Kit	27		
E. Firescreen	8	E. Install Ceiling Firestops	28		
F. Flue Damper	8	F. Install Attic Insulation Shield	29		
G. Refractory	8	G. Cut out Hole in Roof	30		
H. Glass Doors	9	H. Complete Installation	30		
I. Outside Air (optional)	9	I. Install Flashing	30		
J. Vented Gas Log Sets & Gas Log Lighters	9	J. Chimney Termination Requirements	31		
K. Optional Components	9	<b>9 Chase Installations</b>	<b>32</b>		
L. Clear Space	9	A. Construct the Chase	32		
M. Wood Fuel	10	B. Install Fireplace & Chimney	33		
<b>3 Maintenance and Service</b>	<b>11</b>	C. Install Chase Top	33		
A. Disposal of Ashes	11	D. Install Termination Cap	34		
B. Chimney Inspection/Cleaning	11	<b>10 Shrouds</b>	<b>36</b>		
C. Check Firebox Refractory	12	A. Radiation Shield	36		
D. Inspect Grate	12	B. Field Constructed Shrouds	36		
E. Glass Cleaning	12	<b>11 Finishing</b>	<b>38</b>		
<b>4 Troubleshooting Guide</b>	<b>13</b>	A. Non-Combustible Materials	38		
<b>Installer Guide</b>				B. Combustible Materials	38
<b>5 Getting Started</b>	<b>14</b>	C. Hearth Extension	38		
A. Typical Fireplace System	14	D. Finishing Material	40		
B. Design and Installation Considerations	15	E. Combustible Mantel	41		
C. Draft	15	F. Sidewalls/Surrounds	41		
D. Negative Pressure	15	<b>12 Accessories</b>	<b>42</b>		
E. Locating Fireplace & Chimney	16	A. Gas Log/Lighter Provision	42		
F. Tools and Supplies Needed	17	B. Wood Burning Inserts	42		
G. Fireplace System Requirements	17	<b>13 Reference Materials</b>	<b>43</b>		
H. Inspect Fireplace and Components	17	A. Fireplace Dimensions	43		
<b>6 Framing &amp; Clearances</b>	<b>18</b>	B. Optional Components	44		
A. Select Fireplace Location	18	C. Chimney Components	45		
B. Clearances	19	D. Service Parts	48		
C. Sidewalls/Surrounds	20	E. Contact Information	52		
D. Frame the Fireplace	20				

→Warranty

**Hearth & Home Technologies  
LIMITED LIFETIME WARRANTY**

Hearth & Home Technologies, on behalf of its hearth brands ("HHT"), extends the following warranty for HHT gas, wood, pellet, coal and electric hearth appliances that are purchased from an HHT authorized dealer.

**WARRANTY COVERAGE:**

HHT warrants to the original owner of the HHT appliance at the site of installation, and to any transferee taking ownership of the appliance at the site of installation within two years following the date of original purchase, that the HHT appliance will be free from defects in materials and workmanship at the time of manufacture. After installation, if covered components manufactured by HHT are found to be defective in materials or workmanship during the applicable warranty period, HHT will, at its option, repair or replace the covered components. HHT, at its own discretion, may fully discharge all of its obligations under such warranties by replacing the product itself or refunding the verified purchase price of the product itself. The maximum amount recoverable under this warranty is limited to the purchase price of the product. This warranty is subject to conditions, exclusions and limitations as described below.

**WARRANTY PERIOD:**

Warranty coverage begins on the date of original purchase. In the case of new home construction, warranty coverage begins on the date of first occupancy of the dwelling or six months after the sale of the product by an independent, authorized HHT dealer/ distributor, whichever occurs earlier. The warranty shall commence no later than 24 months following the date of product shipment from HHT, regardless of the installation or occupancy date. The warranty period for parts and labor for covered components is produced in the following table.

The term "Limited Lifetime" in the table below is defined as: 20 years from the beginning date of warranty coverage for gas appliances, and 10 years from the beginning date of warranty coverage for wood, pellet, and coal appliances. These time periods reflect the minimum expected useful lives of the designated components under normal operating conditions.

Warranty Period		HHT Manufactured Appliances and Venting							Components Covered
Parts	Labor	Gas	Wood	Pellet	EPA Wood	Coal	Electric	Venting	
1 Year		X	X	X	X	X	X	X	All parts and material except as covered by Conditions, Exclusions, and Limitations listed
2 years				X	X	X			Igniters, electronic components, and glass
		X	X	X	X	X			Factory-installed blowers
			X						Molded refractory panels
3 years				X					Firepots and burnpots
5 years	1 year			X	X				Castings and baffles
7 years	3 years		X	X	X				Manifold tubes, HHT chimney and termination
10 years	1 year	X							Burners, logs and refractory
Limited Lifetime	3 years	X	X	X	X	X			Firebox and heat exchanger
90 Days		X	X	X	X	X	X	X	All replacement parts beyond warranty period

See conditions, exclusions, and limitations on next page.

### **WARRANTY CONDITIONS:**

- This warranty only covers HHT appliances that are purchased through an HHT authorized dealer or distributor. A list of HHT authorized dealers is available on the HHT branded websites.
- This warranty is only valid while the HHT appliance remains at the site of original installation.
- This warranty is only valid in the country in which the HHT authorized dealer or distributor that sold the appliance resides.
- Contact your installing dealer for warranty service. If the installing dealer is unable to provide necessary parts, contact the nearest HHT authorized dealer or supplier. Additional service fees may apply if you are seeking warranty service from a dealer other than the dealer from whom you originally purchased the product.
- Check with your dealer in advance for any costs to you when arranging a warranty call. Travel and shipping charges for parts are not covered by this warranty.

### **WARRANTY EXCLUSIONS:**

This warranty does not cover the following:

- Changes in surface finishes as a result of normal use. As a heating appliance, some changes in color of interior and exterior surface finishes may occur. This is not a flaw and is not covered under warranty.
- Damage to printed, plated, or enameled surfaces caused by fingerprints, accidents, misuse, scratches, melted items, or other external sources and residues left on the plated surfaces from the use of abrasive cleaners or polishes.
- Repair or replacement of parts that are subject to normal wear and tear during the warranty period. These parts include: paint, wood, pellet and coal gaskets, firebricks, grates, flame guides, batteries and the discoloration of glass.
- Minor expansion, contraction, or movement of certain parts causing noise. These conditions are normal and complaints related to this noise are not covered by this warranty.
- Damages resulting from: (1) failure to install, operate, or maintain the appliance in accordance with the installation instructions, operating instructions, and listing agent identification label furnished with the appliance; (2) failure to install the appliance in accordance with local building codes; (3) shipping or improper handling; (4) improper operation, abuse, misuse, continued operation with damaged, corroded or failed components, accident, or improperly/incorrectly performed repairs; (5) environmental conditions, inadequate ventilation, negative pressure, or drafting caused by tightly sealed constructions, insufficient make-up air supply, or handling devices such as exhaust fans or forced air furnaces or other such causes; (6) use of fuels other than those specified in the operating instructions; (7) installation or use of components not supplied with the appliance or any other components not expressly authorized and approved by HHT; (8) modification of the appliance not expressly authorized and approved by HHT in writing; and/or (9) interruptions or fluctuations of electrical power supply to the appliance.
- Non-HHT venting components, hearth components or other accessories used in conjunction with the appliance.
- Any part of a pre-existing fireplace system in which an insert or a decorative gas appliance is installed.
- HHT's obligation under this warranty does not extend to the appliance's capability to heat the desired space. Information is provided to assist the consumer and the dealer in selecting the proper appliance for the application. Consideration must be given to appliance location and configuration, environmental conditions, insulation and air tightness of the structure.

### **This warranty is void if:**

- The appliance has been over-fired or operated in atmospheres contaminated by chlorine, fluorine, or other damaging chemicals. Over-firing can be identified by, but not limited to, warped plates or tubes, rust colored cast iron, bubbling, cracking and discoloration of steel or enamel finishes.
- The appliance is subjected to prolonged periods of dampness or condensation.
- There is any damage to the appliance or other components due to water or weather damage which is the result of, but not limited to, improper chimney or venting installation.

### **LIMITATIONS OF LIABILITY:**

- The owner's exclusive remedy and HHT's sole obligation under this warranty, under any other warranty, express or implied, or in contract, tort or otherwise, shall be limited to replacement, repair, or refund, as specified above. In no event will HHT be liable for any incidental or consequential damages caused by defects in the appliance. Some states do not allow exclusions or limitation of incidental or consequential damages, so these limitations may not apply to you. This warranty gives you specific rights; you may also have other rights, which vary from state to state. EXCEPT TO THE EXTENT PROVIDED BY LAW, HHT MAKES NO EXPRESS WARRANTIES OTHER THAN THE WARRANTY SPECIFIED HEREIN. THE DURATION OF ANY IMPLIED WARRANTY IS LIMITED TO DURATION OF THE EXPRESSED WARRANTY SPECIFIED ABOVE.

# 1 Listing and Code Approvals

---

## A. Appliance Certification

This fireplace system has been tested and listed in accordance with UL 127 standards by Underwriters Laboratories Inc. for installation and operation in the United States.

This fireplace may be installed in sleeping rooms EX-CEPT in manufactured homes. If installed with a gas log set, provisions for the National Fuel Gas Code must be met.

This fireplace has been tested and listed for use with the optional components specified in this manual. These optional components may be purchased separately and installed at a later date. Installation of an outside air kit will require significant reconstruction and is best if installed at the time of fireplace installation.

Heat & Glo is a registered trademark of Hearth & Home Technologies.

**WARNING! Risk of Fire!** *Hearth & Home Technologies disclaims any responsibility for, and the warranty and agency listing will be voided by the following actions.*

### DO NOT:

- *install or operate damaged fireplace*
- *modify fireplace*
- *install other than as instructed by Hearth & Home Technologies*
- *operate the fireplace without fully assembling all components*
- *overfire*
- *install an unvented gas log set*
- *install any component not approved by Hearth & Home Technologies*
- *install parts or components not Listed or approved*

*Improper installation, adjustment, alteration, service or maintenance can cause injury or property damage. For assistance or additional information, consult a qualified installer, service agency or your dealer.*

**NOTICE:** *This fireplace is tested and approved as a decorative fireplace. It should not be factored as a primary heat source in residential heating calculations.*

## B. Non-Combustible Materials

- Materials which will not ignite and burn, composed of any combination of the following:
  - Steel
  - Iron
  - Brick
  - Tile
  - Concrete
  - Slate
  - Glass
  - Plasters
- Materials reported as passing **ASTM E 136, Standard Test Method for Behavior of Metals, in a Vertical Tube Furnace at 750° C**

## C. Combustible Materials

- Materials made of or surfaced with any of the following materials:
  - Wood
  - Compressed paper
  - Plant fibers
  - Plastic
- Any material that can ignite and burn; flame proofed or not, plastered or un-plastered

# User Guide

## 2 Operating Instructions

### ⚠ WARNING



#### HOT SURFACES!

Glass and other surfaces are hot during operation AND cool down.

#### Hot glass will cause burns.

- **DO NOT** touch glass until it is cooled
- NEVER allow children to touch glass
- Keep children away
- CAREFULLY SUPERVISE children in same room as fireplace.
- Alert children and adults to hazards of high temperatures.

#### High temperatures may ignite clothing or other flammable materials.

- Keep clothing, furniture, draperies and other flammable materials away.

If you expect that children may come into contact with this fireplace, we recommend a barrier such as a decorative screen. See your dealer for suggestions.

### A. Your Fireplace

**WARNING! DO NOT** operate fireplace before reading and understanding operating instructions. Failure to operate fireplace according to operating instructions could cause fire or injury.

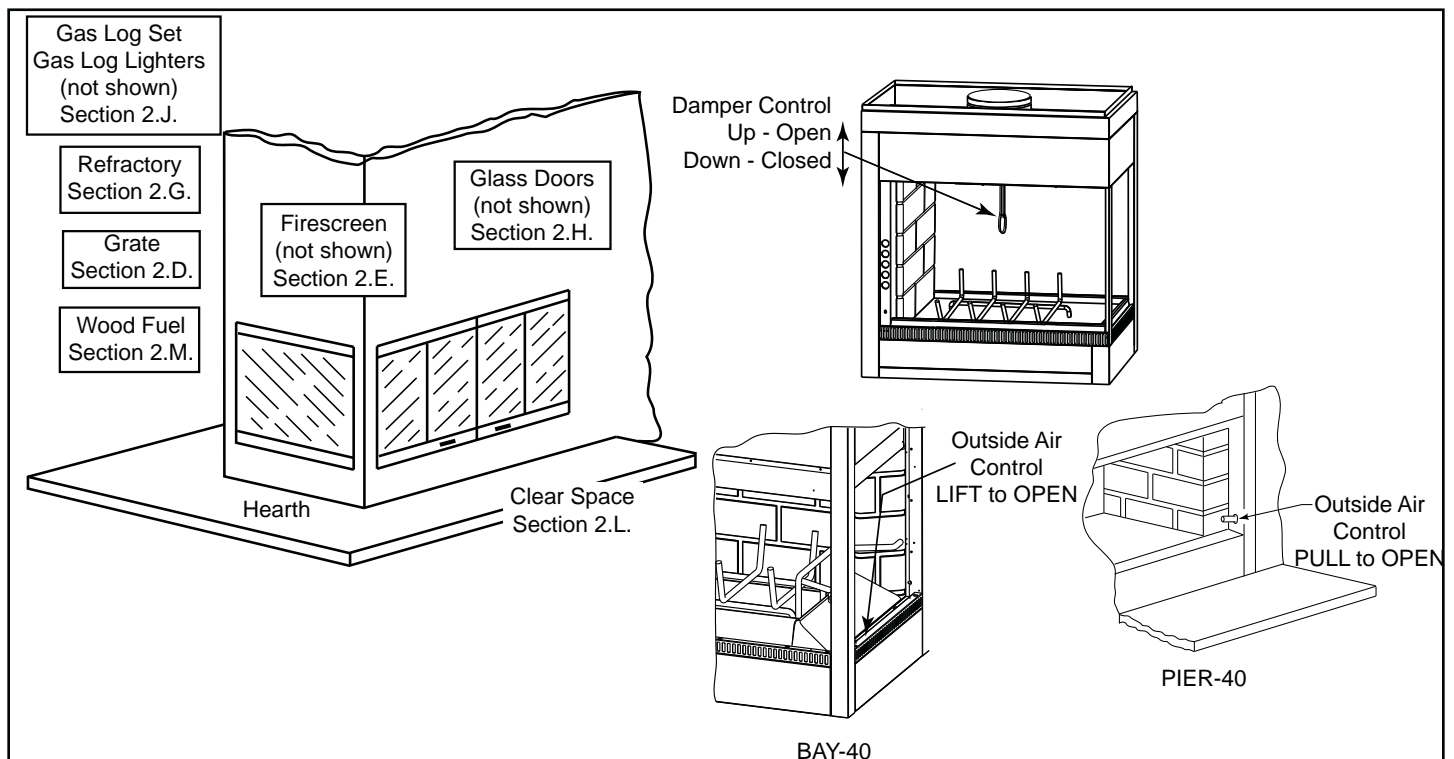

Figure 2.1 General Operating Parts

## B. Seasoned Wood

Properly seasoned wood is important for successful operation of your fireplace. Most woodburning fireplace problems are caused by burning wet, unseasoned wood.

Seasoned firewood is wood that is cut to size, split and air dried to a moisture content of around 20%.

Imagine a wooden bucket that weighs about eight pounds. Fill it with a gallon of water, put it in the fireplace and try to burn it. This sounds ridiculous but that is exactly what you are doing if you burn unseasoned wood.

A tree cut down a year ago and not split is likely to have almost as high a moisture content now as it did when it was cut.

Please refer to Section 2.M. for more detail.

## C. Starting a Fire

**NOTICE:** You must establish a good draft to prevent smoke spillage into the room.

**WARNING! Risk of Fire!** Keep combustible materials, gasoline and other flammable vapors and liquids clear of the fireplace.

### DO NOT:

- store flammable materials close to the fireplace
- use gasoline, lantern fuel, kerosene, charcoal lighter fluid or similar liquids to start or “freshen up” a fire in this fireplace.

Keep all flammable liquids well away from the fireplace while it is in use. Combustible materials may ignite.

- The first three or four fires should be of moderate size to allow the oils and binders to be burned from the fireplace and the refractory and paint to cure. You may notice an industrial odor the first few fires. This is considered normal.
- Use well-seasoned wood.
- Open the flue damper to a fully open position.
- Place crumpled or twisted paper under the fireplace grate.
- Loosely arrange kindling or small pieces of wood to form a ‘tent’ on the fireplace grate.
- Pre-warm the flue to establish a draft to help reduce smoke spillage during start-up. Hold a rolled up piece of burning newspaper under the flue damper for a few moments.
- Light the crumpled paper to ignite the kindling.
- Add small pieces of wood until a hot bed of embers has been established.
- Add a minimum of three average size pieces of split firewood, placed to allow combustion air and flames between them.

**CAUTION!** Odors and vapors released during initial operation may be irritating to sensitive individuals.  
**Open windows for air circulation.**

## D. Grate

This fireplace is designed to be used with the grate supplied with this unit or one approved by HHT. The grate will break down over time and will need occasional replacement.

**WARNING! Risk of Fire!** Use only the factory-supplied integral grate.

- Keeps logs in place.
- Allows proper air circulation around the fire.

## E. Firescreen

The firescreen is provided to control sparks. Keep it closed when the fireplace is in use.

**WARNING! Risk of Fire or Burns!**

- Screen will not prevent burning materials from falling out.
- Screen pulls or handles may be hot.

## F. Flue Damper

- Refer to Figure 2.1 for location of control.
- Must be in fully open position (handle up toward the top of the fireplace) during operation of the fireplace.
- Before lighting the fireplace, verify fully open position by looking up from the inside of the fireplace.

**WARNING! Risk of Fire and Asphyxiation!** Open damper prior to operating fireplace. A closed damper overfires the fireplace and spills smoke and flames into the room.

## G. Refractory

- The refractory is supplied to contain heat and provide an attractive interior.
- It will break down over time and will need occasional replacement. Small hairline cracks and discoloration are normal and do not affect its safety.
- (See refractory maintenance Section 3.C.)

**WARNING! Risk of Fire! DO NOT** burn fireplace without refractory. Use only refractory supplied by Hearth & Home Technologies.



## H. Glass Doors

- Glass doors are optional.
- Refer to Figure 2.2 for how to properly use them.

**WARNING! Risk of Fire!** Install *ONLY* doors approved by Hearth & Home Technologies.

**WARNING! Risk of Fire and Smoke!** Fireplaces equipped with doors should be operated only with doors fully open or doors fully closed. If doors are left partly open, gas and flame may be drawn out of the fireplace opening.

## I. Outside Air (optional)

The outside air kit supplies some combustion air for your fireplace. It may help reduce the effects of negative air pressure. (See Section 5.D.)

- Refer to Figure 2.1 for location of control
- Close the inlet to prevent cold drafts when the fireplace is not being used.

**CAUTION! Risk of Burns!** The outside air control handle is *HOT* when fireplace is in operation. Adjust *BEFORE* lighting fire.

## J. Vented Gas Log Sets & Gas Log Lighters

- Optional
- Vented gas logs or gas log lighters can be installed in this fireplace. Follow the instructions provided with the accessory for operation.

**WARNING! Risk of Fire or Asphyxiation!**

- **DO NOT** install unvented gas logs.
- Damper must be locked open.
- Gas flame may generate fumes.

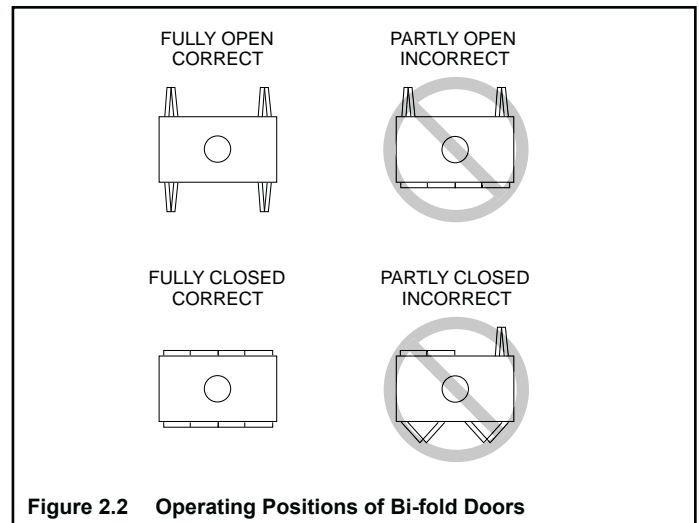

Figure 2.2 Operating Positions of Bi-fold Doors

## K. Optional Components

- Other options may be available
- Consult your dealer/distributor

**WARNING! Risk of Fire! DO NOT** install and or use any component not approved by Hearth & Home Technologies.

## L. Clear Space

- Do not place combustible objects within areas indicated in Figure 2.3.

**WARNING! DO NOT** place combustible objects in front of the fireplace. High temperatures may ignite clothing, furniture or draperies.

- Mantel - avoid placing candles and other heat-sensitive objects on mantel or hearth. Heat may damage these objects.

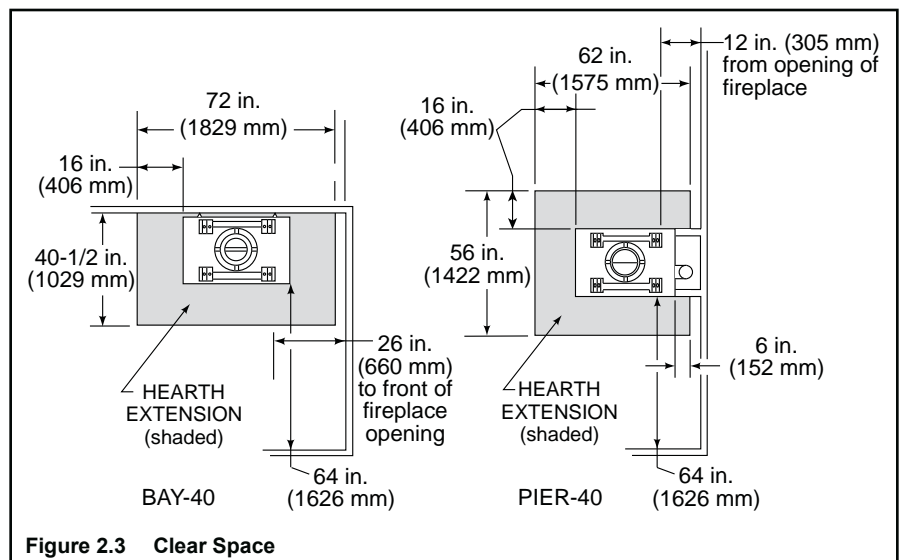

Figure 2.3 Clear Space

## M. Wood Fuel

### Hardwood vs Softwood

Your fireplace performance depends on the quality of the firewood you use.

- Seasoned wood contains about 8,000 BTUs per pound
- Hard woods are more dense than soft woods.
- Hard woods contain 60% more BTUs than soft woods.
- Hard woods require more time to season, burn slower and are harder to ignite.
- Soft woods require less time to dry, burn faster and are easier to ignite.
- Start the fire with soft wood to bring the fireplace up to operating temperature and to establish draft.
- Add hard wood for slow, even heat and longer burn time.

Soft woods	Hard woods
<ul style="list-style-type: none"><li>• Douglas Fir</li><li>• Pine</li><li>• Spruce</li><li>• Cedar</li><li>• Poplar</li><li>• Aspen</li><li>• Alder</li></ul>	<ul style="list-style-type: none"><li>• Oak</li><li>• Maple</li><li>• Apple</li><li>• Birch</li></ul>

### Moisture

#### **WARNING! Risk of Fire!**

- **DO NOT** burn wet or green wood.
- Wet, unseasoned wood can cause accumulation of creosote.

The majority of the problems fireplace owners experience are caused by trying to burn wet, unseasoned wood.

- Wet, unseasoned wood requires energy to evaporate the water instead of heating your home, and
- Evaporating moisture cools your chimney, accelerating formation of creosote.

### Seasoned Wood

- Cut logs to size
- Split to 6 in. (152 mm) or less
- Air dry to a moisture content of around 20%
  - Soft wood - about nine months
  - Hard wood - about eighteen months

**NOTICE:** Seasoning time may vary depending on drying conditions.

### Storing Wood

Steps to ensure properly seasoned wood:

- Stack wood to allow air to circulate freely around and through woodpile.
- Elevate wood pile off ground to allow air circulation underneath.
- Smaller pieces of wood dry faster. Any piece over 6 in. (152 mm) in diameter should be split.
- Wood (whole or split) should be stacked so both ends of each peice are exposed to air. More drying occurs through the cut ends than the sides.
- Store wood under cover to prevent water absorbtion from rain or snow. Avoid covering the sides and ends completely.

**WARNING! Fire Risk! DO NOT** store wood:

- In front of the fireplace.
- In space required for loading or ash removal.

### Processed Solid Fuel Firelogs

Manufactured firelogs may be used with this fireplace. Hearth & Home Technologies recommends the use of UL Classified processed fuel firelogs. Follow the manufacturer's lighting and safety instructions.

Using firelogs may require more frequent chimney inspection and cleaning.

Do not poke or stir the logs while they are burning. Use only firelogs that have been evaluated for the application in manufactured fireplaces and refer to firelog warnings and caution markings on packaging prior to use.

# 3 Maintenance and Service

## A. Disposal of Ashes

**Frequency:** When they reach bottom of grate

**By:** Homeowner

**WARNING! Risk of Fire!** Ashes could contain hot embers.

- Place ashes in a metal container with a tight-fitting lid.
- The closed container should be placed on a non-combustible floor or on the ground, well away from all combustible materials, pending final disposal.
- If the ashes are disposed of by burial in soil or otherwise locally dispersed, they should be retained in the closed container until all cinders have thoroughly cooled.

## B. Chimney Inspection/Cleaning

**Frequency:** At least twice a year during heating season or as recommended by a certified chimney sweep

**By:** Certified chimney sweep

**WARNING! Risk of Fire!** Ignited creosote is extremely HOT. Prevent creosote buildup.

Refer to Figure 3.1 to remove/reinstall termination caps.

### Creosote - Formation and Need for Removal

When wood is burned slowly, it produces tar and other organic vapors, which combine with expelled moisture to form creosote. The creosote vapors condense in the relatively cool chimney flue of a slow-burning fire. As a result, creosote residue accumulates on the flue lining. When ignited this creosote makes an extremely hot fire.

**WARNING! Risk of Fire!** A chimney fire can permanently damage your chimney system and nearby structures.

In the event of a chimney fire, Hearth & Home Technologies recommends

- replacement of the chimney, and
- inspection of the adjacent structure to the provisions of NFPA Level III inspection criteria.

The chimney shall be inspected at least twice a year during the heating season to determine when a creosote buildup has occurred.

When creosote has accumulated it shall be removed to reduce the risk of a chimney fire.

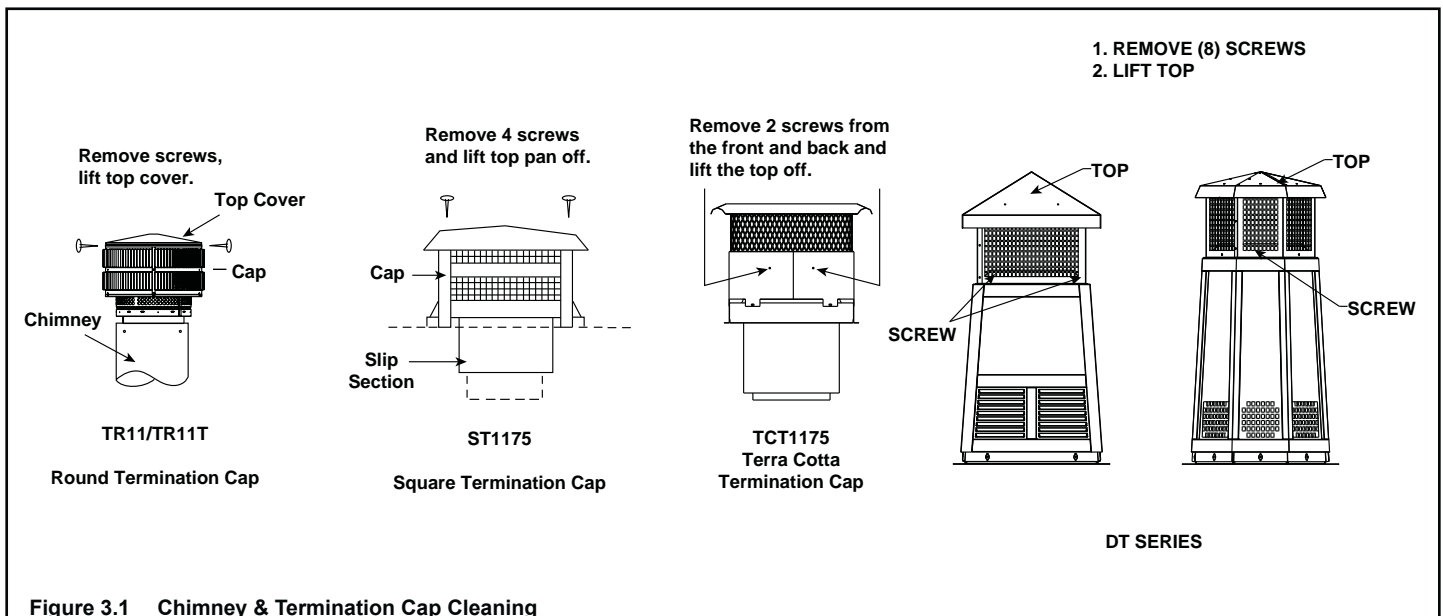

Figure 3.1 Chimney & Termination Cap Cleaning

## C. Check Firebox Refractory

**Frequency:** After each ash removal

**By:** Homeowner

**WARNING! Risk of Fire!** *Inspect fireplace refractory. Crumbling, deteriorated refractory can allow overheating of surrounding materials.*

Expansion and contraction will cause minor cracking of the refractory. This is normal. The refractory will require periodic replacement depending on use.

The panels should be replaced if

- Cracks exceed ¼ inch (6 mm) in width,
- Metal is exposed behind the refractory,
- Large pieces of refractory fall out.

## D. Inspect Grate

**Frequency:** After each ash removal

**By:** Homeowner

Inspect grate for:

- Warping or sagging 1-1/2 in. (38 mm) or more
- Broken welds
- Burn-through of grate bars

For safe operation, replace only with an approved grate from Hearth & Homes Technologies.

## E. Glass Cleaning

**Frequency:** As desired

**By:** Homeowner

**CAUTION!** *Handle glass assembly with care. Glass is breakable.*

- *Avoid striking, scratching or slamming glass*
- *Avoid abrasive cleaners*
- **DO NOT** *clean glass while it is hot*

Clean glass with a non-abrasive commercially available cleaner or ashes:

- Light deposits
  - Use household glass cleaner
- Heavy deposits
  - Use wood ash on damp cloth or,
  - Use commercial fireplace glass cleaner (consult with your dealer)

# 4 Troubleshooting Guide

Start Fire Problems	Possible Cause	Solution
Can't get fire started Excessive smoke or spillage Burns too slowly Smolders, sizzles	Not enough kindling/paper or no kindling/paper	Use dry kindling, more paper. Arrange kindling & wood for air movement.
	Damper closed/not fully open	Open damper.
	Not enough air for fire to ignite	Check for restricted cap/shroud.
		Open air kit (if installed).
		Check for flue blockage.
		Pre-warm flue before starting fire (refer to starting fire section).
		Check for adequate vent height (refer to chimney assembly section).
	Open window below the fireplace towards the wind.	
	Wood condition is too wet, too large	Use dry, seasoned wood (refer to wood fuel section).
	Bed of coals not established before adding wood	Start with paper & kindling to establish bed of coals (refer to starting fire section).
Flue blockage such as birds' nests or leaves in termination cap	Have chimney inspected for creosote and cleaned by a certified chimney sweep.	
Down draft or negative pressure Competition with exhaust devices	Do not use exhaust fans during start-up (refer to negative pressure section).	
	Open window below the fireplace towards the wind.	
Fire burns too fast	Extremely dry or soft wood	Mix in hardwood.
		Mix in less seasoned wood after fire is established (refer to wood fuel section).
	No glass doors	Add glass doors to slow down air flow.
	Overdrafting	Check for correct vent height; too much vertical height creates overdrafting.
Check location of vent termination (refer to chimney assembly section).		

# Installer Guide

## 5 Getting Started

### A. Typical Fireplace System

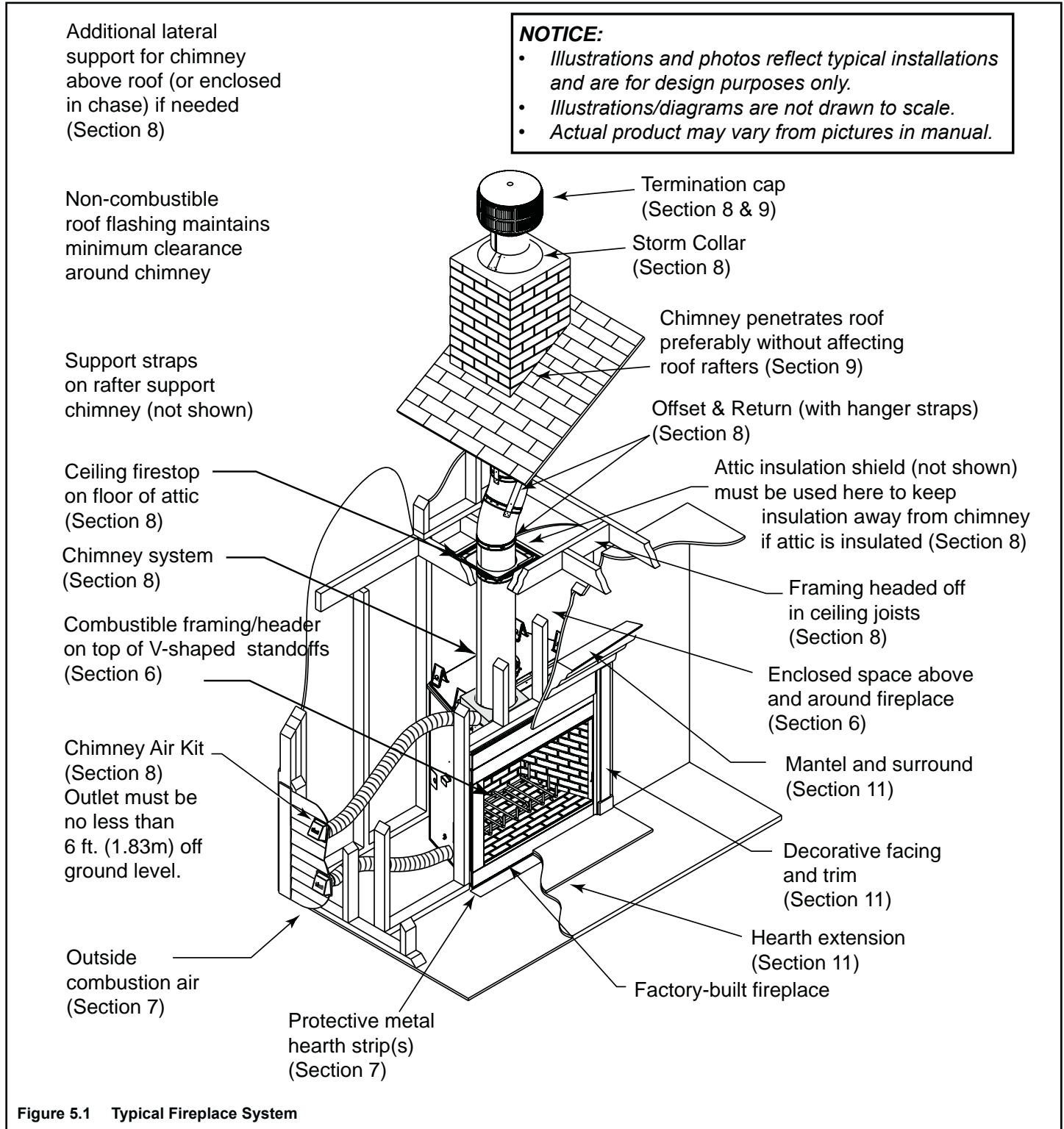

## B. Design and Installation Considerations

**NOTICE:** Check building codes prior to installation.

- Installation MUST comply with local, regional, state and national codes and regulations.
- Consult insurance carrier, local building inspector, fire officials or authorities having jurisdiction over restrictions, installation inspection and permits.

Before installing, determine the following:

- Where the fireplace is to be installed
- The vent system configuration to be used
- Gas supply piping
- Electrical wiring
- Framing and finishing details
- Whether optional accessories—devices such as a fan, wall switch or remote control—are desired

**NOTICE:** Junction box should be installed during initial setup to avoid major reconstruction.

## C. Draft

Draft is the pressure difference needed to vent fireplaces successfully. When a fireplace is drafting successfully, all combustion byproducts are exiting the home through the chimney.

Considerations for successful draft include:

- Preventing negative pressure
- Location of fireplace and chimney

**NOTICE:** *Hearth & Home Technologies assumes no responsibility for the improper performance of the fireplace system caused by:*

- *Inadequate draft due to environmental conditions*
- *Downdrafts*
- *Tight sealing construction of the structure*
- *Mechanical exhausting devices*
- *Improper location of the chimney*

## D. Negative Pressure

**WARNING! Risk of Asphyxiation!** Negative pressure can cause spillage of combustion fumes and soot. Fire must draft properly for safe operation.

Negative pressure results from the imbalance of air available for the fireplace to operate properly. It can be strongest in lower levels of the house.

Causes include:

- Exhaust fans (kitchen, bath, etc.)
- Range hoods
- Combustion air requirements for furnaces, water heaters and other combustion appliances
- Clothes dryers
- Location of return-air vents to furnace or air conditioning
- Imbalances of the HVAC air handling system
- Upper level air leaks such as:
  - Recessed lighting
  - Attic hatch
  - Duct leaks

To minimize the effects of negative air pressure:

- Install the outside air kit with the intake facing prevailing winds during the heating season
- Ensure adequate outdoor air for all combustion appliances and exhaust equipment
- Ensure furnace and air conditioning return vents are not located in the immediate vicinity of the fireplace
- Avoid installing the fireplace near doors, walkways or small isolated spaces
- Recessed lighting should be a “sealed can” design
- Attic hatches weather stripped or sealed
- Attic mounted duct work and air handler joints and seams taped or sealed
- Basement installations should be avoided

**NOTICE:** *Hearth & Home Technologies recommends the use of direct vent fireplaces in basements.*

## E. Locating Fireplace & Chimney

Location of the fireplace and chimney will affect performance.

- Install within the warm airspace enclosed by the building envelope. This helps to produce more draft, especially during lighting and die-down of the fire.
- Penetrate the highest part of the roof. This minimizes the effects of wind loading.
- Locate termination cap away from trees, adjacent structures, uneven roof lines and other obstructions.
- Minimize the use of chimney offsets.
- Consider the fireplace location relative to floor and ceiling and attic joists.
- Take into consideration the termination requirements in Section 8 and Section 9.

**NOTICE:** Locating the fireplace in a basement or in a location of considerable air movement can cause intermittent smoke spillage from fireplace. Do not locate fireplace near

- frequently open doors
- central heat outlets or returns

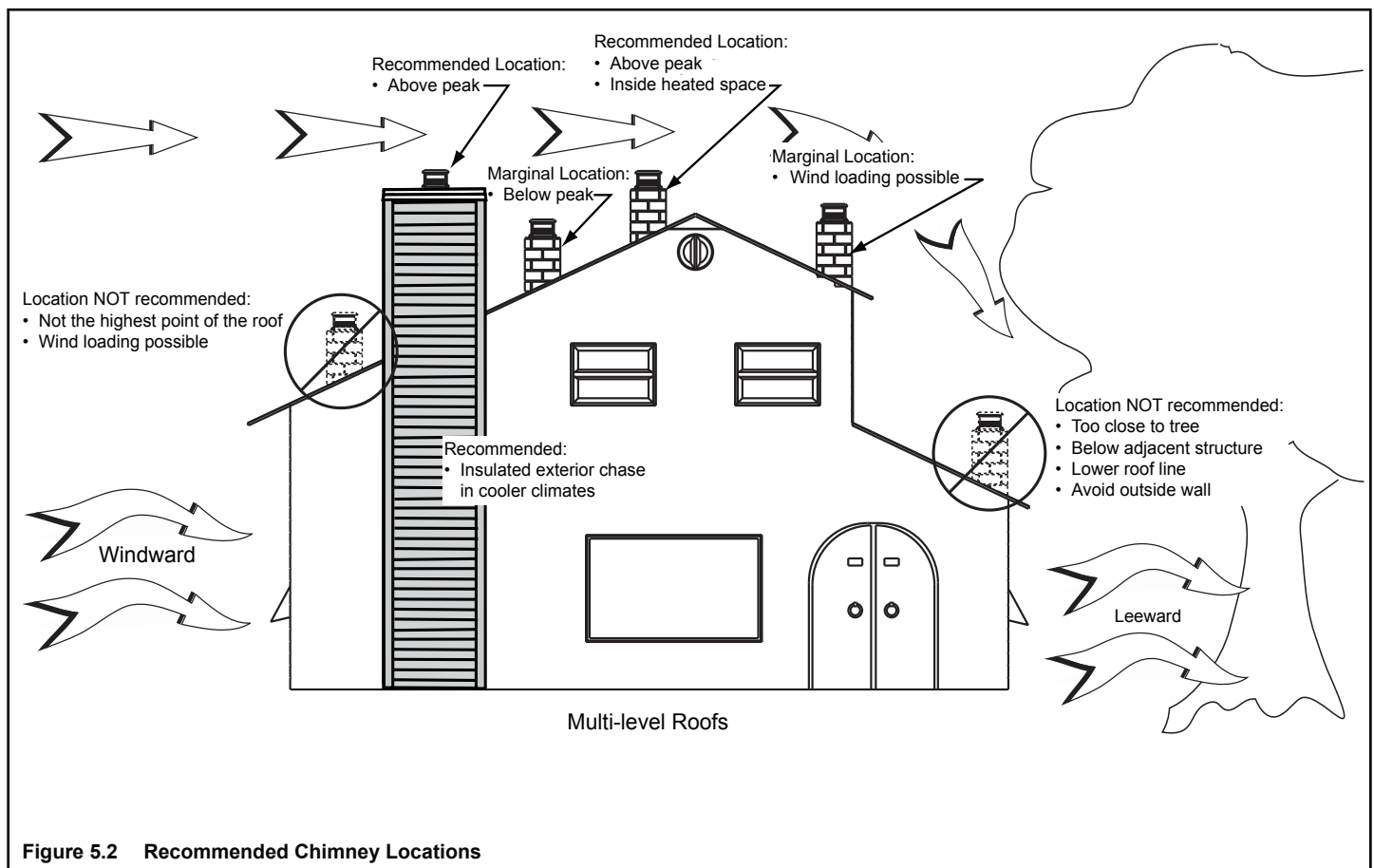



## F. Tools and Supplies Needed

Before beginning the installation be sure the following tools and building supplies are available:

Reciprocating saw	Framing material
Pliers	Non-combustible sealant
Hammer	Gloves
Phillips screwdriver	Framing square
Flat blade screwdriver	Electric drill and bits
Plumb line	Safety glasses
Level	Tape measure
1/2-3/4 in. length, #6 or #8 self-drilling screws	
Misc. screws and nails	

## G. Fireplace System Requirements

This fireplace system requires:

- Fireplace
- Hearth Refractory
- Grate Assembly
- Hearth Extension (required, sold separately)
- Outside Air Kit
  - Duct (required for outside air installation, sold separately)
- Chimney System (required, sold separately)
- Termination Cap (required, sold separately)

## H. Inspect Fireplace and Components

**WARNING! Risk of Fire and/or Explosion! Damaged parts could impair safe operation. DO NOT install damaged, incomplete or substitute components. Keep fireplace dry.**

- Remove fireplace and components from packaging and inspect for damage.
- Vent system components and doors are shipped in separate packages.
- Report to your dealer any parts damaged in shipment.
- **Read all the instructions before starting the installation. Follow these instructions carefully during the installation to ensure maximum safety and benefit.**

# 6 Framing & Clearances

## A. Select Fireplace Location

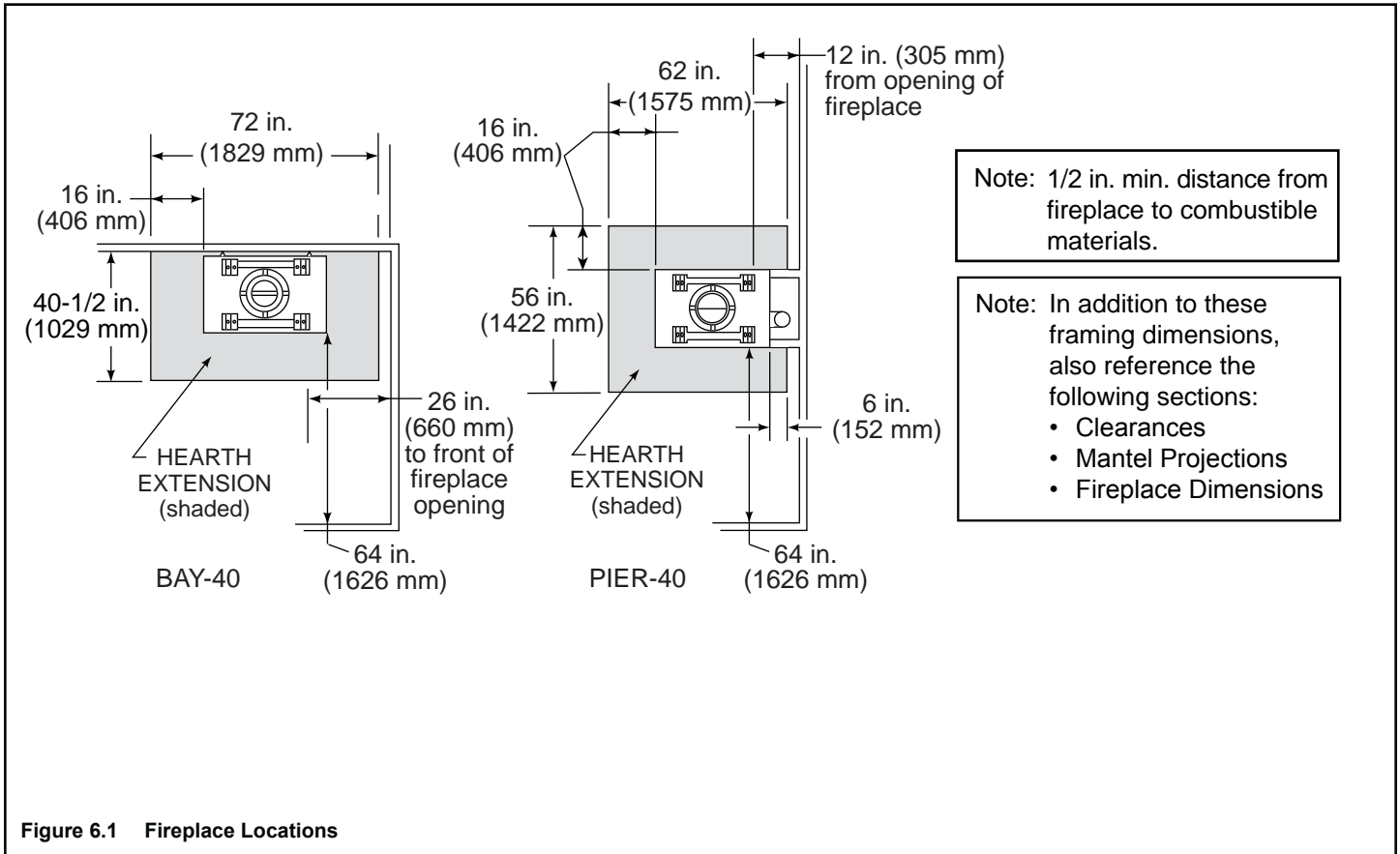

Figure 6.1 Fireplace Locations

## B. Clearances

**WARNING! Risk of Fire!** You must comply with all minimum air space clearances to combustibles as specified in Figure 6.2. **DO NOT** pack required air spaces with insulation or other materials.

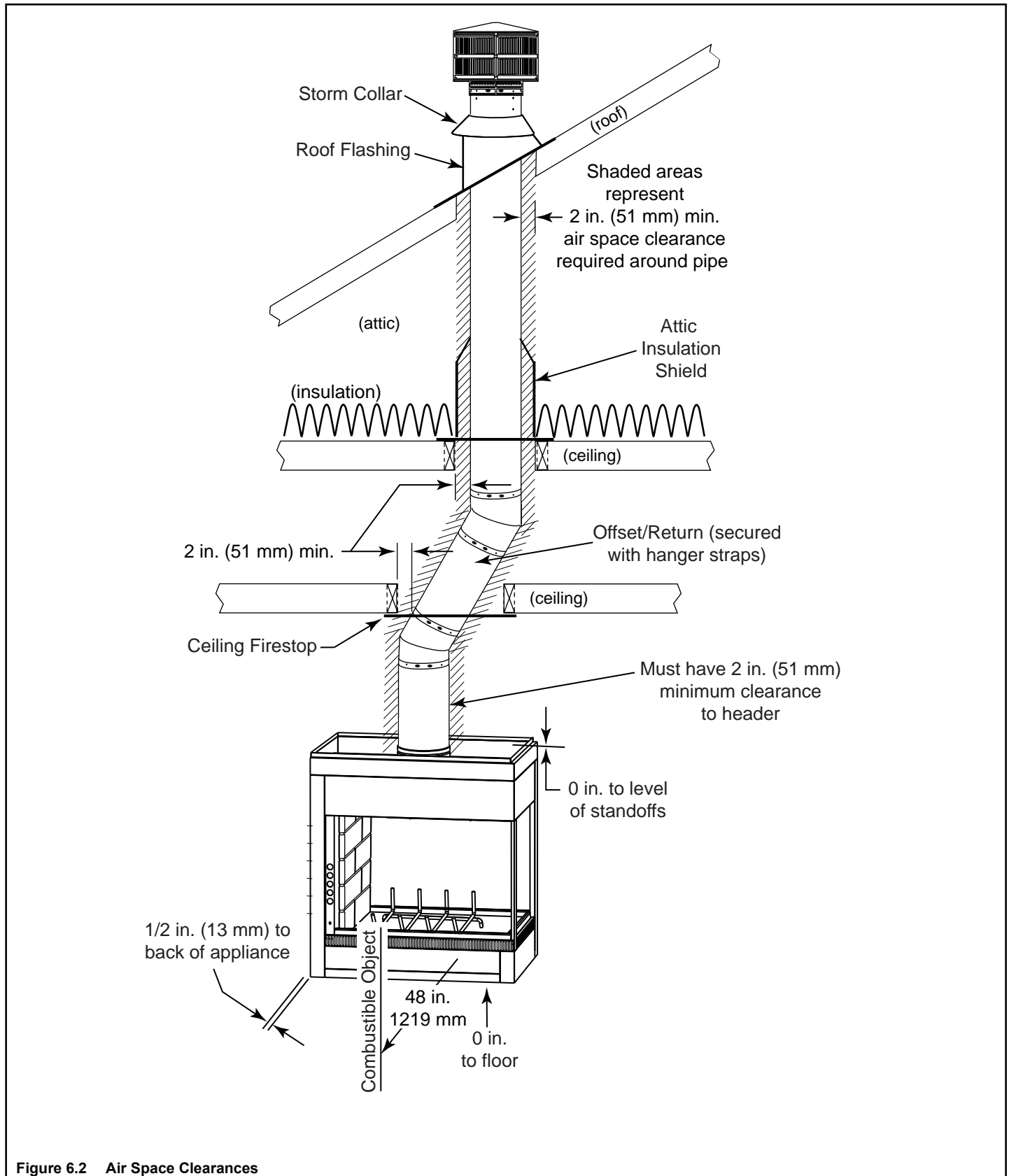
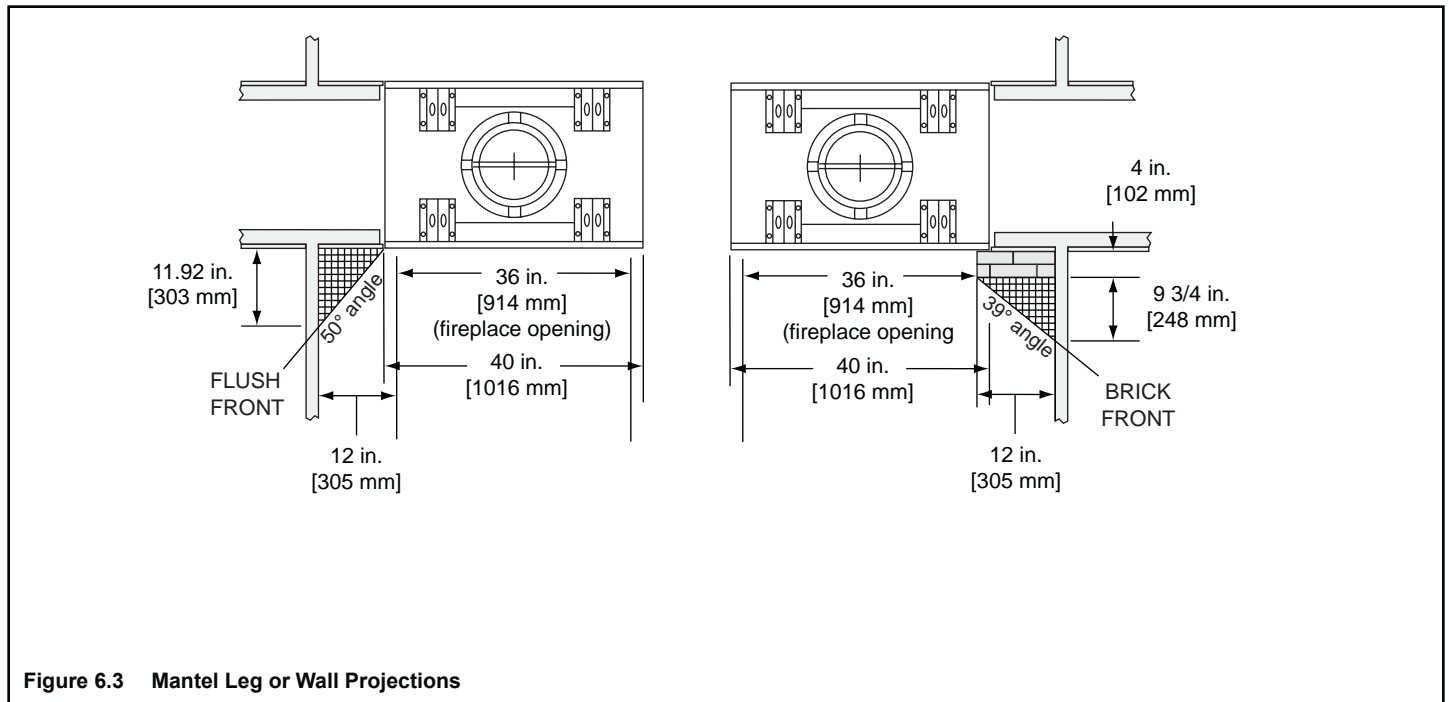

Figure 6.2 Air Space Clearances

### C. Sidewalls/Surrounds

- Adjacent combustible sidewalls must be located a minimum of 12 in. (305 mm) from the fireplace opening.
- Combustible and non-combustible mantel legs, surrounds and stub walls may be constructed within the gridded area, Figure 6.3.



### D. Frame the Fireplace

Figure 6.4 shows typical framing using combustible materials (2x4 lumber shown).

- Observe all required air space clearances to combustible materials as shown in Figure 6.1 & 6.2.
- Framing across the top of fireplace must be above top standoffs.

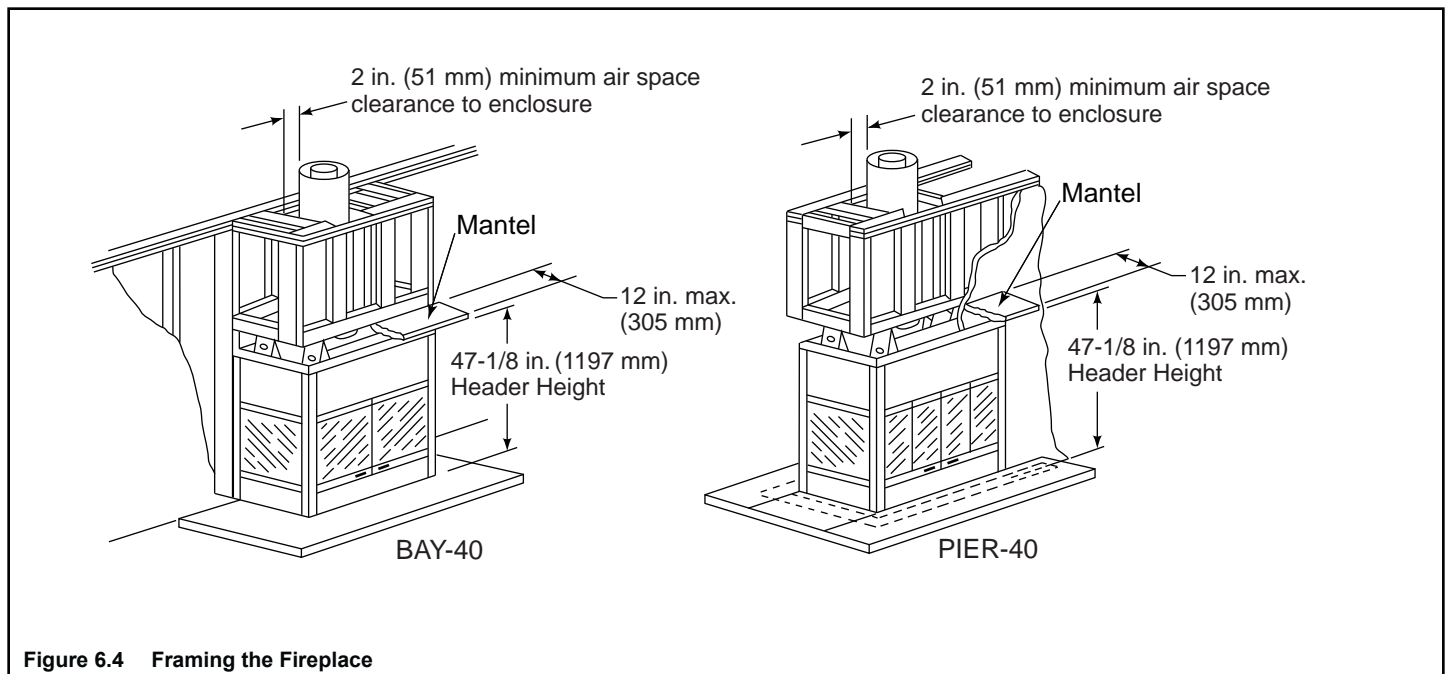

# 7 Installation of Fireplace

**CAUTION! Risk of Cuts/Abrasions.** Wear protective gloves and safety glasses during installation. Sheet metal edges are sharp.

## A. Things to Consider

- Location of chimney air kit inlet (see Figure 5.1 & 7.4)
- Location of outside air kit
- Electrical connections and/or wall switch
- Gas line piping

## B. Position the Fireplace

- Place the fireplace on a continuous flat surface.
- Follow framing instructions in Section 6.

**WARNING! Risk of Fire!** Prevent contact with sagging, loose insulation.

- **DO NOT** install against vapor barriers or exposed insulation.
- Secure insulation and vapor barriers.
- Provide minimum air space clearances at the sides and back of the fireplace assembly as outlined in Section 6.

## C. Place Protective Metal Hearth Strips

**WARNING! Risk of Fire!** Protective metal hearth strips **MUST** be installed. **DO NOT** cover metal strips with combustible materials. Sparks or embers may ignite flooring.

- Refer to Figures 7.1 and 7.2.
- Locate the two protective metal hearth strips measuring approximately 26 in. x 4 in. (660 mm x 102 mm) included with this fireplace.
- Slide each metal strip 2 in. (51 mm) under front edge of fireplace.
- Overlap strips in the middle of fireplace opening by 1 in. (25 mm) minimum.
- Metal strips must extend beyond the front and sides of the fireplace opening by at least 2 in. (51 mm).
- Protect the front of a platform elevated above the hearth extension with metal strips (not included with fireplace) per Figure 7.2. See Section 11 for hearth extension instructions.

## D. Level Fireplace

- Level fireplace side-to-side and front-to-back.
- Shim with non-combustible material as necessary.
- Secure fireplace to framing with nailing flanges with a minimum of two fasteners per nailing flange.
- Check fireplace opening for square to ensure proper fit of glass doors. Measure diagonals of fireplace opening to make sure they are equal.

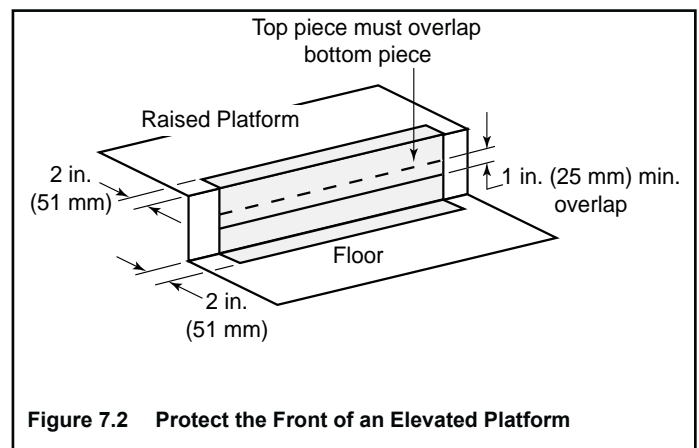
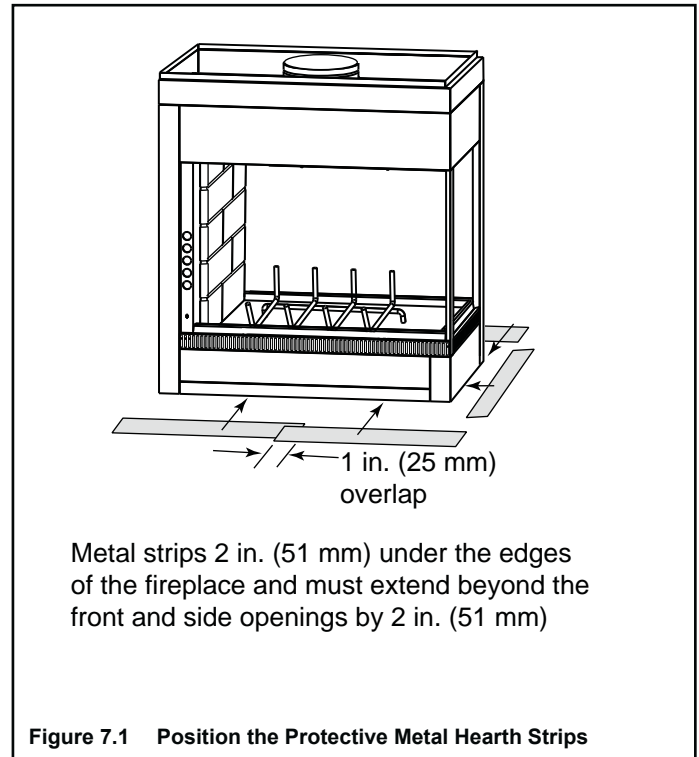

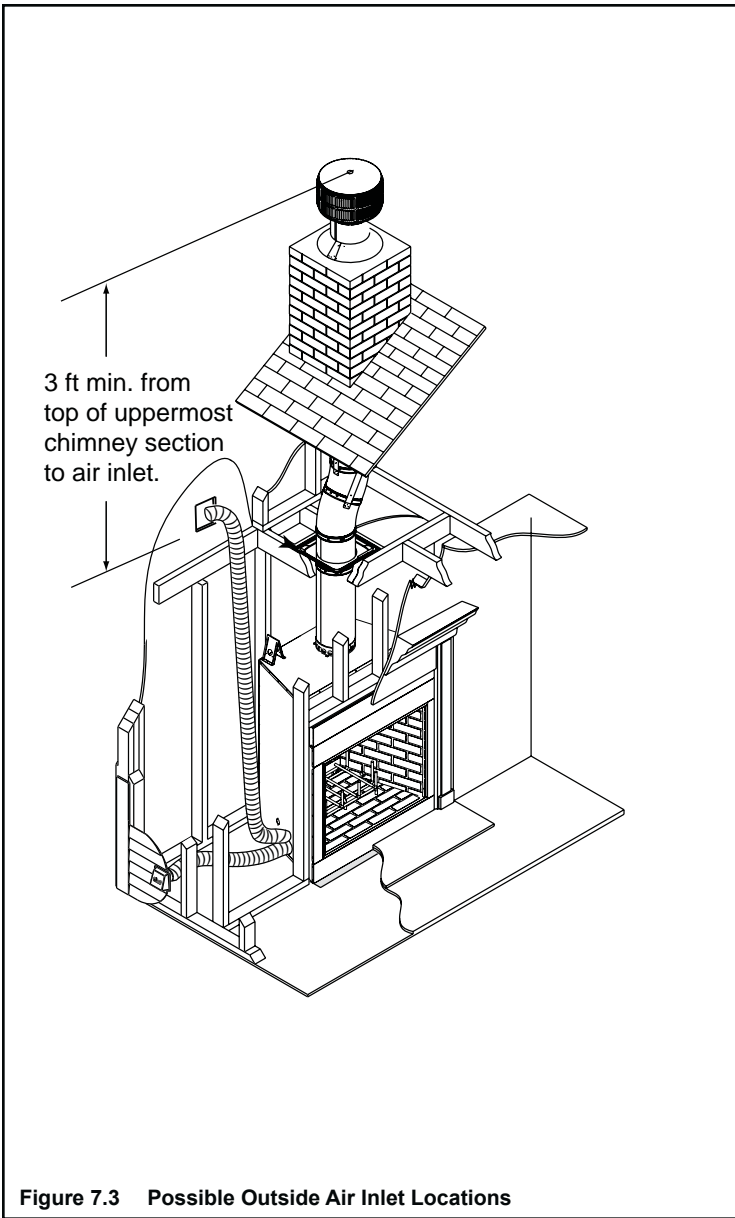

Figure 7.3 Possible Outside Air Inlet Locations

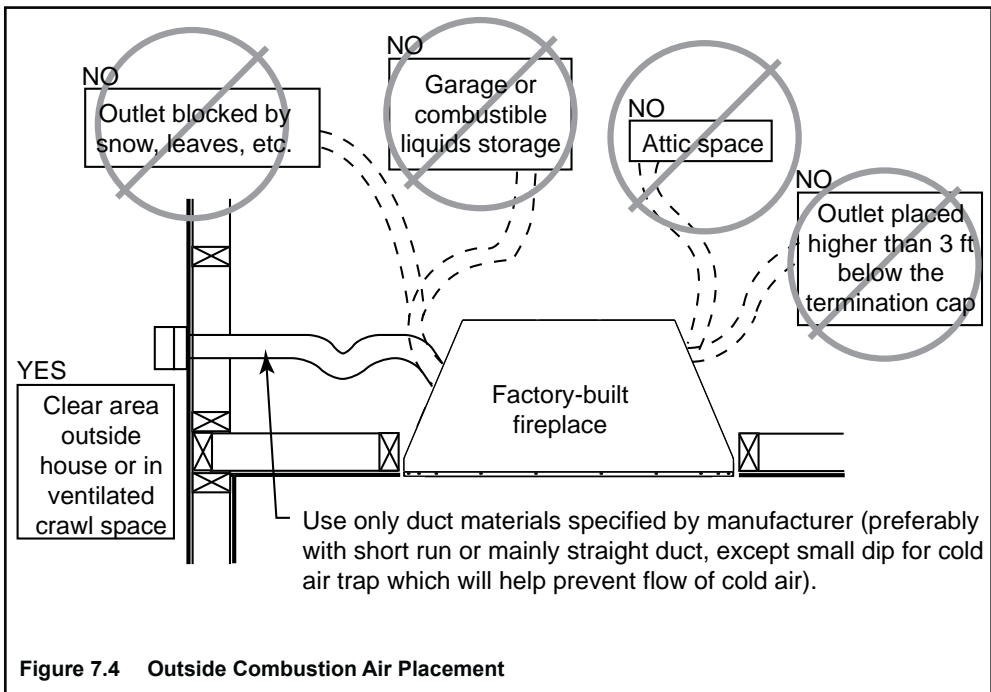

Figure 7.4 Outside Combustion Air Placement

## E. Install Outside Air Kit

- Keep duct runs short and straight to minimize restriction. A small dip is acceptable for a cold air trap.
- The outside air kit must be installed on the left hand side of the fireplace.
- Locate the outside air hood in a clear area, preferably into prevailing wind during the heating season. Refer to Figure 5.2.
- Install as shown in Figures 7.3 - 7.5.
- The air duct may be run vertically.
- The outside air hood must be at least 3 ft (.91 m) below the top of the uppermost chimney section.

**CAUTION! Risk of Fire or Asphyxiation! DO NOT draw outside combustion air from wall, floor or ceiling cavity, or enclosed spaces such as an attic or garage.**

- **DO NOT** place outside air hood close to exhaust vents or chimneys. Fumes or odor could be drawn into the room through the fireplace.
- Locate outside air inlet to prevent blockage from leaves, snow/ice, or other debris. Blockages could cause combustion air starvation.

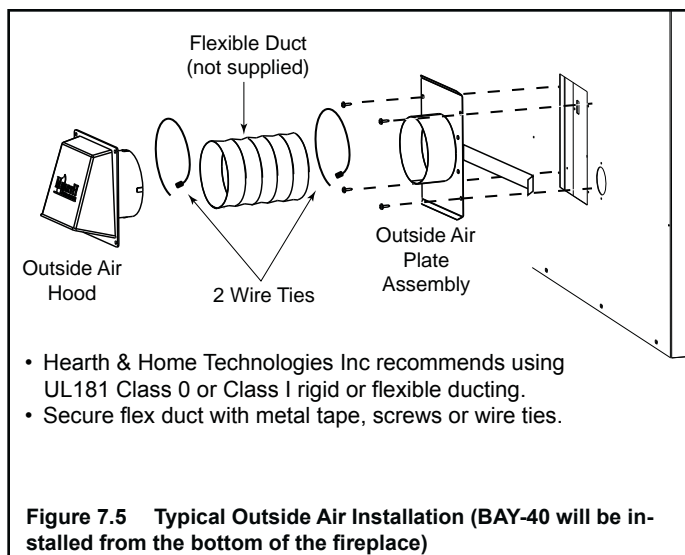

Figure 7.5 Typical Outside Air Installation (BAY-40 will be installed from the bottom of the fireplace)

## AK17 Installation (BAY-40)

- Remove the cover plate from the bottom of the fireplace and replace it with outside air plate assembly using existing screws.
- Mark and cut out a 4 1/2 in. (114 mm) diameter hole in the building side for air entry. This hole should allow for some framing (two sides) so the outside air hood assembly may be nailed into position, flush with building's outside.
- Secure flexible duct (not supplied) to the plate assembly.
- Feed duct through hole to the outside, fasten to the hood assembly.
- Fasten outside air hood assembly to the structure with screws.

**Note:** To guard against significant cold air infiltration through duct or other parts of system, check for light leaks with a flashlight and seal these with duct tape and/or insulation.

## AK14/AK18 Installation (PIER-40)

- The hinge will be toward the front of the fireplace.
- Insert the narrow end of the handle into the upper slot.
- Pivot the handle in the slot toward the hinge.
- Remove the cover plate or knockout from the side of the fireplace and discard. Remove the semi-perforated piece of insulation covering the opening (insulated fireplaces only).
- Partly open the air kit door and insert the handle into the appropriate hole in the side column of the fireplace. The hinge on the door assembly should be located toward the front of the fireplace. If the hinge and the handle are not positioned in this manner, the door will not function correctly.
- Attach the door assembly to the fireplace using the screws provided.
- Check operation by pulling the handle out to open and pushing it in to close.
- Mark and cut out a 4 1/2 in. (114 mm) hole in the building side for air entry. This hole should allow some framing (two sides) so the 4 in. (102 mm) diameter inlet tube assembly may be fastened properly.
- Assemble flexible duct (not supplied) between the door assembly and the inlet tube assembly. Secure it in position with the supplied wire ties.

# 8 Chimney Assembly

**NOTICE:** Chimney performance may vary.

- Trees, buildings, roof lines and wind conditions affect performance.
- Chimney height may need adjustment if smoking or overdraft occurs.

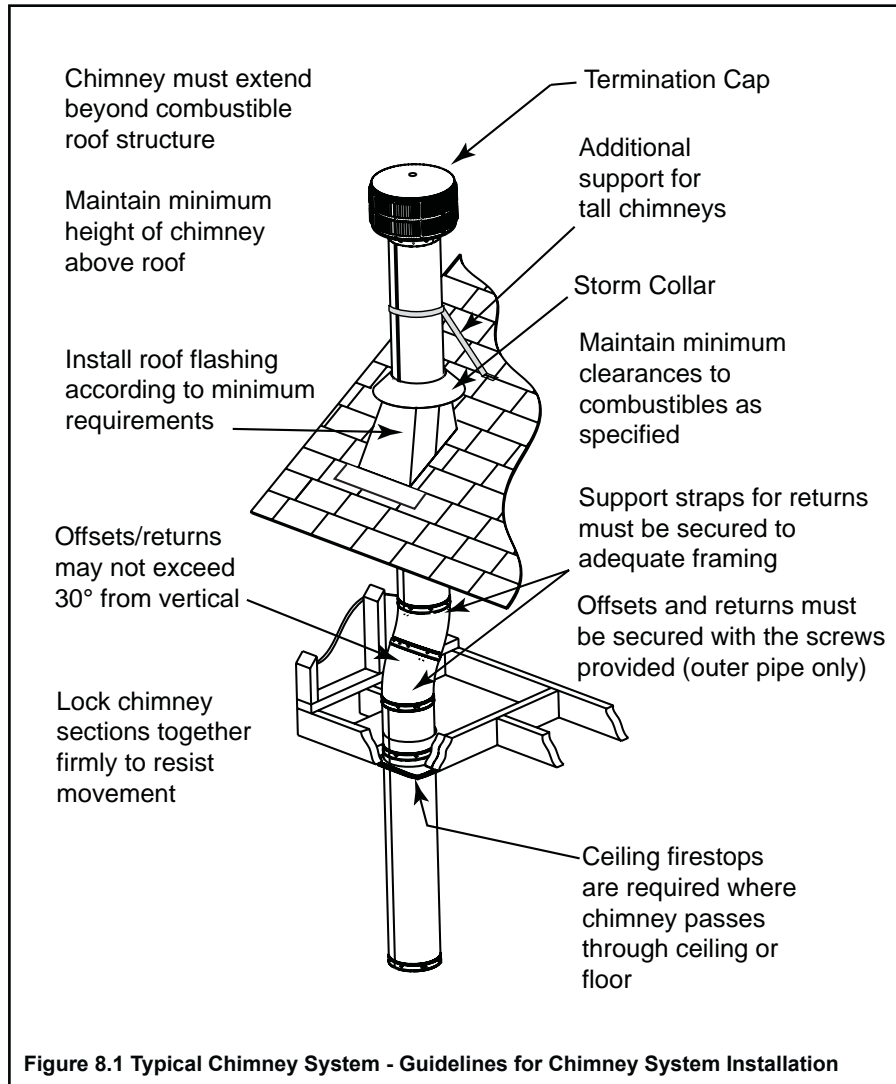



## A. Chimney Requirements

Measure vertical distances from the base of the fireplace as shown in Figure 8.2.

- Minimum overall straight height 14 (4.27 m)
- Minimum height with offset/return 16.5 ft (5.03 m)
- Maximum height 90 ft (27.43 m)
- Maximum chimney length between an offset and return 20 ft (6.1 m)
- Maximum distance between chimney stabilizers 35 ft (10.67 m)
- Double offset/return minimum height 20 ft (6.1 m)
- Maximum unsupported chimney length between the offset and return 6 ft (1.83 m)
- Maximum unsupported chimney height above the fireplace 35 ft (10.67 m)
- Maximum unsupported chimney above roof 6 ft (1.83 m)

**WARNING! Risk of Fire!** You must maintain 2 in. (51 mm) air space clearance to insulation and other combustible materials around the chimney system. Failure to do so may cause overheating and fire.

Table 8.1

HEIGHT OF CHIMNEY COMPONENTS		in.	mm
<b>Chimney Stabilizer</b>			
	SL11	4-3/4	121
<b>Ceiling Firestops</b>			
	FS538	0	0
	FS540	0	0
<b>Offsets&gt;Returns</b>			
	SL1130	18	457
<b>Roof Flashing</b>			
	RF570	0	0
	RF571	0	0
<b>Chimney Sections*</b>			
	SL1106	4-3/4	121
	SL1112	10-3/4	273
	SL1118	16-3/4	425
	SL1136	34-3/4	883
	SL1148	46-3/4	1187

\* Dimensions reflect effective height.

Determine the chimney components needed to complete your particular installation:

- Measure the total vertical height of the fireplace installation from the base of the fireplace assembly to the approximate location of the bottom of the termination cap.
- Subtract the effective height of the fireplace assembly (see Figure 8.2) from the total vertical height to determine the overall height of the chimney installation.
- Create a schematic for your application similar to Figure 8.2 showing components required (referring to Table 8.1). Figure 8.1 identifies those components and where used.
- Install a ceiling firestop whenever the chimney penetrates a floor/ceiling.

**NOTICE:** A maximum of two pairs of offsets and returns may be used.

**CAUTION! Risk of Fire and/or Asphyxiation! DO NOT** connect this fireplace to a chimney flue servicing another appliance. **DO NOT** connect to any air distribution duct or system. These actions could cause overheating/fire in the chimney flue, or release of exhaust fumes into the living areas.

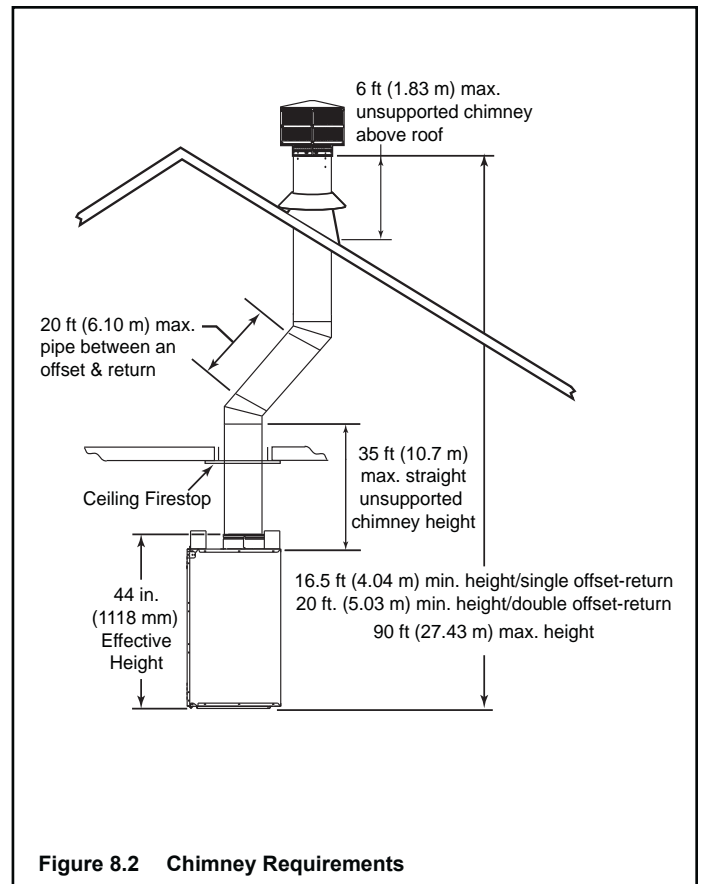

Figure 8.2 Chimney Requirements

## B. Using Offsets/Returns

- Use an offset/return to bypass overhead obstructions.
- An offset and return can be used as a single entity or separated by chimney section(s).

**WARNING! Risk of Fire! DO NOT use offset/returns greater than 30°. Chimney draft will be restricted and could cause overheating and fire.**

- Measure the shift needed to avoid the overhead obstruction. Refer to dimension A in Figure 8.3.
- Find the appropriate A dimension listed in Table 8.2.
- The B dimension coinciding with the A dimension measurement in Table 8.2 represents the required vertical clearance needed to complete the offset/return.
- Read across the chart to find the number of chimney sections/model numbers needed between the offset and return.

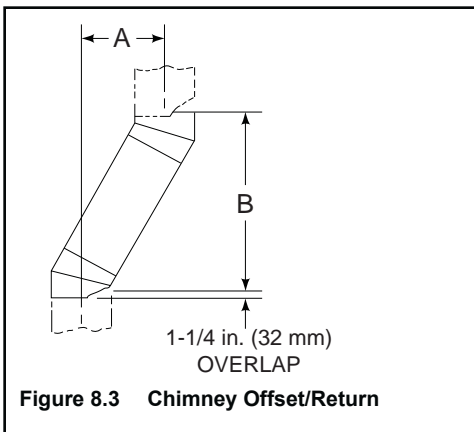

Figure 8.3 Chimney Offset/Return

### Example:

Your “A” dimension from Figure 8.3 is 14 1/2 in. (368 mm). Using Table 8.2 the dimension closest to, but not less than 14 1/2 in. (368 mm) is 15 3/4 in. (400 mm) using a 30° offset/return.

You determined from the table that you would need 36 5/8 in. (930 mm) (Dimension “B”) between the offset and return.

The chimney component that best fits your application is two SL1112s.

Table 8.2

A		B		SL1106	SL1112	SL1118	SL1136	SL1148
in.	mm	in.	mm					
4 7/8	124	17 7/8	454	-	-	-	-	-
7 1/4	184	22	559	1	-	-	-	-
9 3/4	248	26 1/8	664	2	-	-	-	-
10 1/4	260	27 1/4	692	-	1	-	-	-
12 3/4	324	31 3/8	797	1	1	-	-	-
13 1/4	337	32 3/8	822	-	-	1	-	-
15 3/4	400	36 5/8	930	-	2	-	-	-
18 1/8	460	40 3/4	1035	1	2	-	-	-
18 3/4	476	41 3/4	1060	-	1	1	-	-
21 3/4	552	47	1194	-	-	2	-	-
22 1/4	565	4 8	1219	-	-	-	1	-
24 3/4	629	52 1/8	1324	1	-	-	1	-
27 3/4	705	57 3/8	1457	-	1	-	1	-
28 1/4	718	58 3/8	1483	-	-	-	-	1
30 3/4	781	62 1/2	1588	1	-	-	-	1
33 3/4	857	67 3/4	1721	-	1	-	-	1
36 3/4	933	73	1854	-	-	1	-	1
39 3/4	1010	78 1/8	1984	-	-	-	2	-
41 1/8	1045	82 3/8	2092	1	-	-	2	-
45 3/4	1162	88 1/2	2248	-	-	-	1	1
48 1/8	1222	92 3/4	2356	1	-	-	1	1
51 3/4	1314	98 7/8	2511	-	-	-	-	2

Proper assembly of air cooled chimney parts results in an overlap of chimney joints of 1-1/4 in. (32 mm). Effective length is built into this table.

## C. Assemble Chimney Sections

**WARNING! Risk of Fire! DO NOT** install substitute or damaged chimney components.

• Use only those components described in this manual. Substitute or damaged chimney components could impair safe operation and cause overheating and fire.

- Support the pipe during construction and check to be sure inadvertent loading has not dislodged the chimney section from the fireplace or at any chimney joint.
- Attach a straight chimney section or an offset to the top of the fireplace.
- Place inner flue to the inside of the chimney section below it. Place the outer casing outside the outer casing of the chimney section below it. Refer to Figure 8.4.

**NOTICE:** Chimney sections cannot be disassembled once locked together. Plan ahead!

- Lock chimney sections and/or offsets/returns together by pushing downward until the top section meets the stop bead on the lower section.
- Pull on the top section to make sure it is fully engaged and will not separate.
- You may use #6 or #8 sheet metal screws no longer than 1/2 in. (13 mm) to fasten chimney sections together. Do NOT penetrate inner flue.

**WARNING! Risk of Fire! You MUST use screws (provided) to fasten offset/returns to chimney sections to keep the chimney parts from twisting. Failure to do so could cause fire.**

- Fasten offset/returns to chimney sections. Insert the screws (provided) through the predrilled holes. Do NOT penetrate inner flue.
- Secure chimney returns with hanger straps provided; fasten to studs or joists.
- Vertical straight runs of chimney must be supported every 35 ft (10.7 m).

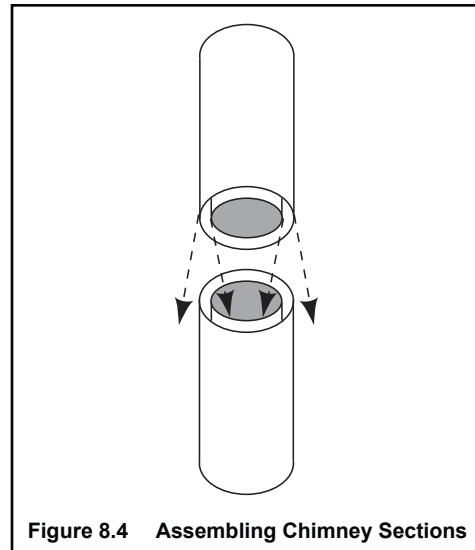

Figure 8.4 Assembling Chimney Sections

## D. Install Chimney Air Kit

Follow instructions provided with this accessory.

## E. Install Ceiling Firestops

**CAUTION! Risk of Fire!** Ceiling firestops must be used whenever the chimney penetrates a ceiling/floor.

- Chase construction requires ceiling firestops at each floor or every 10 ft (3.05 m) of clear space.
- The ceiling firestop slows spread of fire and reduces cold air infiltration.
- Install a ceiling firestop whenever chimney penetrates ceiling/floor.
- Mark and cut an opening in ceiling as shown in Figure 8.5.
- Frame the opening with the same size lumber used in the ceiling joists.
- Nail the ceiling firestop to the bottom of the ceiling joists when there is a room above.
- Use an attic insulation shield if the ceiling is insulated. The ceiling firestop may then be attached above or below the joists.

**WARNING! Risk of Fire! DO NOT** seal area between firestop opening and chimney pipe except where they enter the attic or leave the warm air envelope of the home (use 600° F sealant).

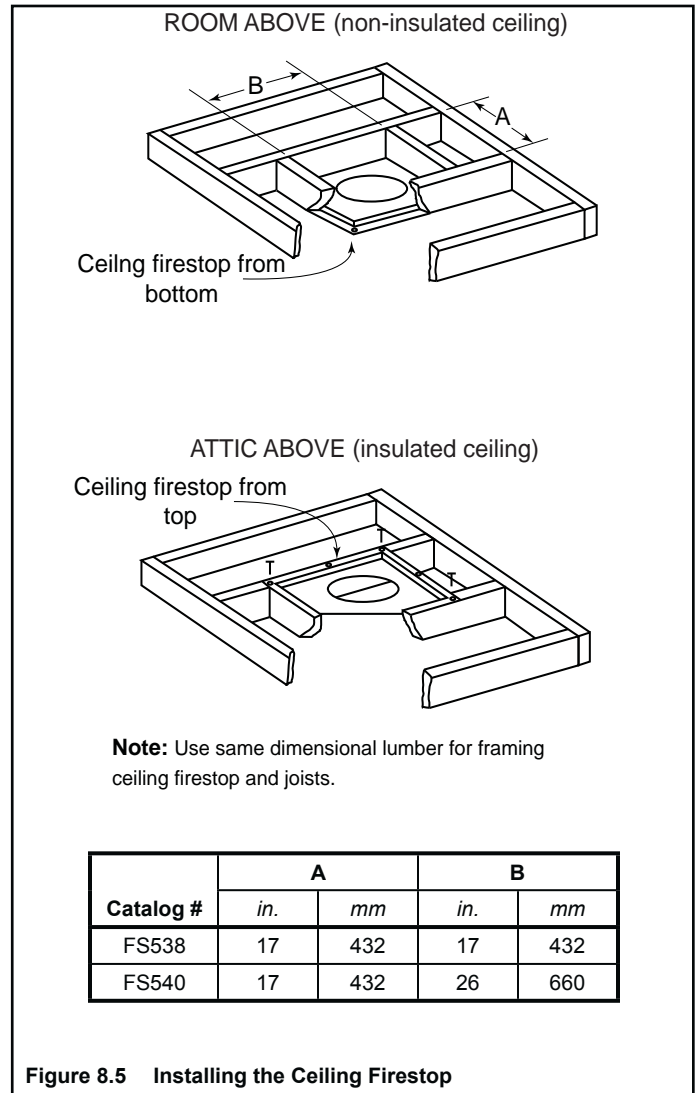

Figure 8.5 Installing the Ceiling Firestop

## F. Install Attic Insulation Shield

**WARNING! Risk of Fire!** You **MUST** install an attic insulation shield when there is any possibility of insulation or other combustible material coming into contact with the chimney.

- **DO NOT** pack insulation between the chimney and the attic insulation shield.
- Failure to keep insulation and other materials away from chimney pipe could cause fire.
- **DO NOT** offset chimney inside insulation shield.

Installation of a ceiling firestop is required

- Refer to Figures 8.6 - 8.8.
- Roll the shield (around the chimney if already installed) until you have a 3 in. (76 mm) overlap and the three holes on each side match up (large holes on top).
- Insert three screws into the matching holes to form a tube.
- Bend three tabs on the bottom of the tube inward to 90° to maintain chimney air space (refer to Figure 8.6).
- Rest the insulation shield on the ceiling firestop below.
- Bend the three short tabs at the top of the shield inward to 90° to maintain the 2 in. (51 mm) air space from the chimney.
- Bend the remaining top tabs to just meet the pipe.

If you wish to make a custom shield or barrier, follow these guidelines:

- Metal is preferred, although any material stiff enough to hold back the insulation can be used.

**WARNING! Risk of Fire!** Use of cardboard or other materials that can deflect under humidity or other environmental conditions is not recommended.

- The shield or barrier must be tall enough to extend above the insulation and prevent blown-in insulation from spilling into the cavity.
- Maintain specified air spaces around chimney.
- Check instructions and local codes for further details.

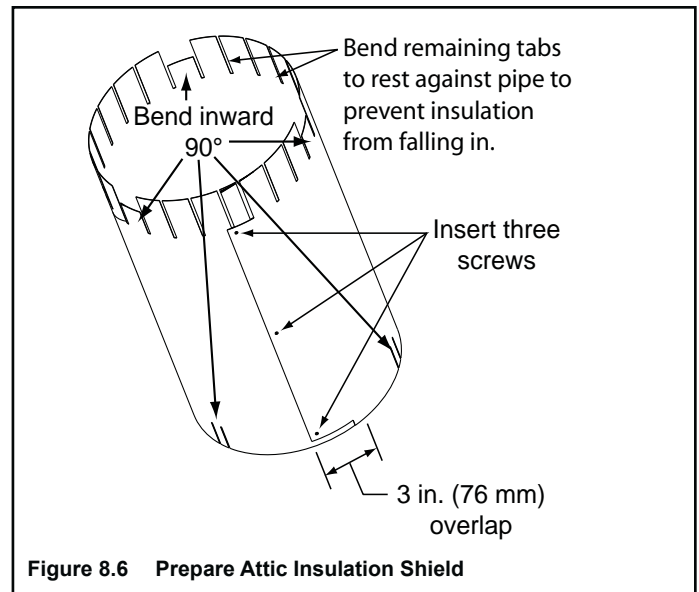

Figure 8.6 Prepare Attic Insulation Shield

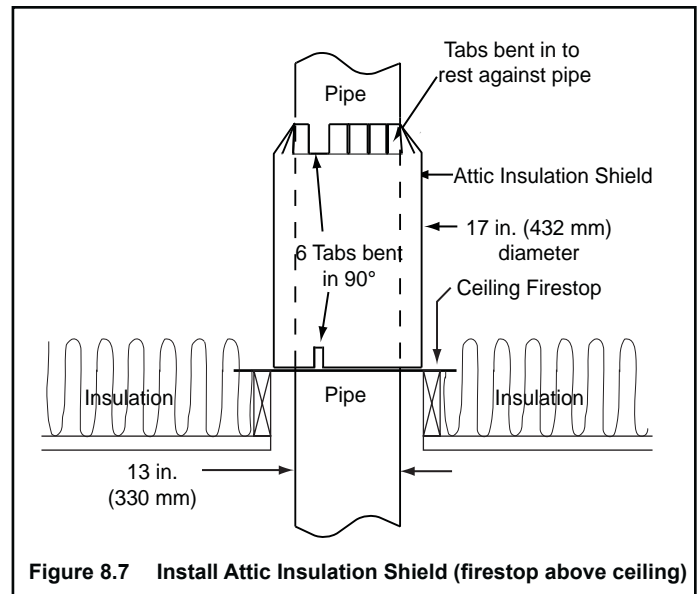

Figure 8.7 Install Attic Insulation Shield (firestop above ceiling)

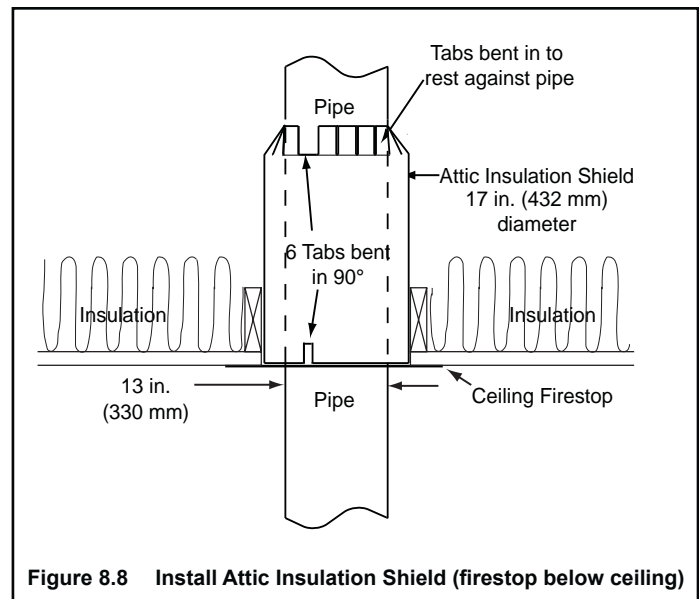

Figure 8.8 Install Attic Insulation Shield (firestop below ceiling)

## G. Cut out Hole in Roof

- Refer to Figure 8.9.
- Plumb from roof to center of chimney.
- Drive a nail up through roof to mark center of pipe.
- Measure to either side of nail and mark the 17 in. x 17 in. (432 mm x 432 mm) opening required.
- Measure opening on the horizontal; actual length may be larger depending on roof pitch.
- Cut out and frame opening.
- Refer to **Chapter 25** of the **Uniform Building Code** for roof framing details.

## H. Complete Installation

**WARNING! Risk of Fire!** You **MUST** maintain 2 in. (51 mm) air space to insulation and other combustible materials around the chimney system. Failure to do so could cause overheating and fire.

- Keep chimney sections from separating or twisting.
- You may secure straight chimney sections at the joints with screws no longer than 1/2 in. (13 mm).

**The following steps should be skipped if using a chase.**

- Install roof flashing appropriate to roof pitch.
- Install round termination cap and storm collar.

## I. Install Flashing

- Assemble chimney so it passes through the framed opening.
- Slip the flashing over the chimney.

**NOTICE:** Roofing shingles must be below the flashing plate on the lower side of a sloped roof and over the flashing plate on the sides and top.

- Nail the flashing to the roof. Keep gaps between the flashing plate and the roof to a minimum.
- Caulk the flashing plate and roof junction as well as the vertical seam on the flashing. All nail heads must be caulked with a roofing sealant.

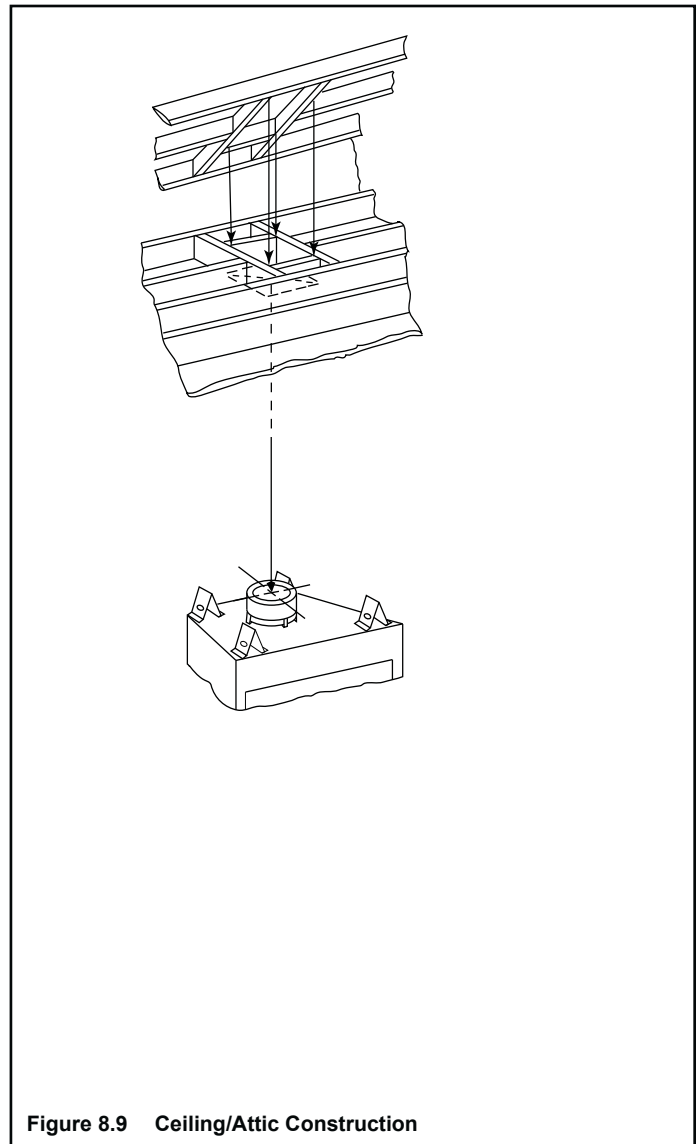
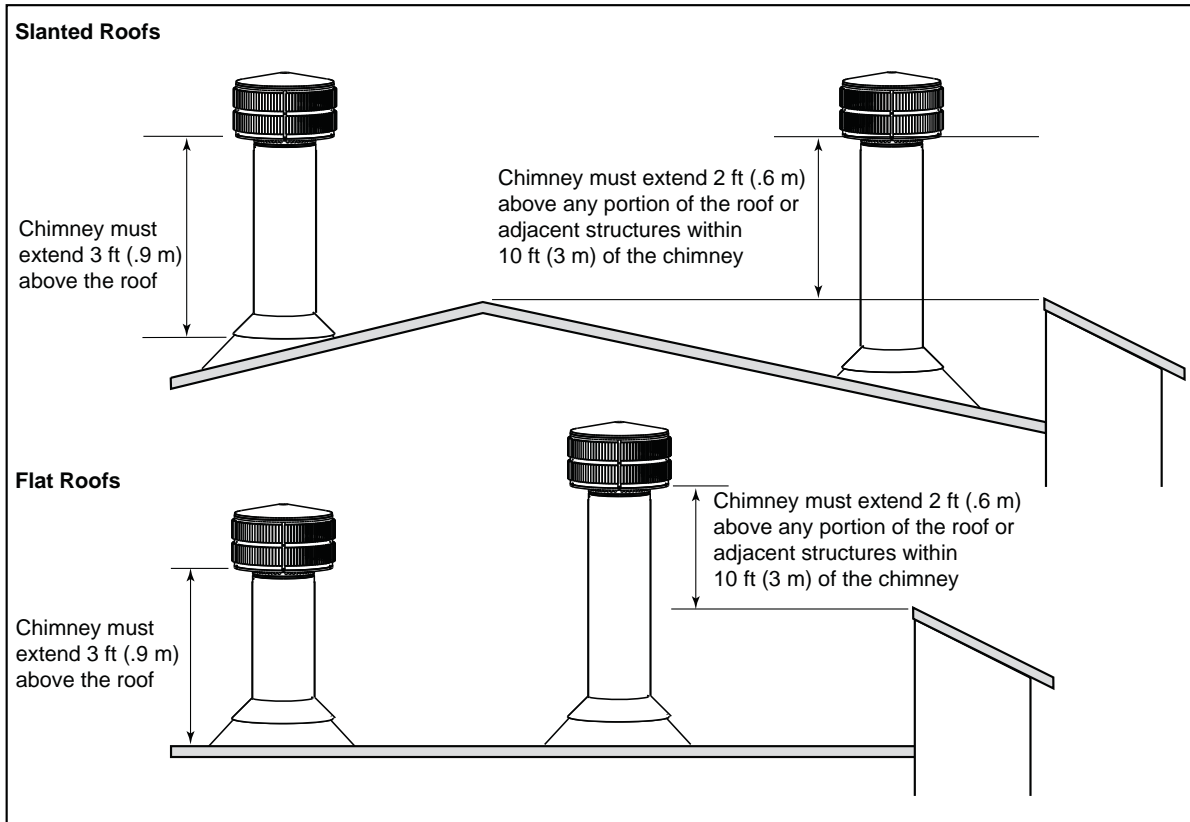

Figure 8.9 Ceiling/Attic Construction

## J. Chimney Termination Requirements

- Install a cap approved and listed for this fireplace system.
- Locate cap where it will not become plugged by snow or other materials.
- Locate cap away from trees or other structures.
- The bottom of the termination cap must be at least 3 ft (.91 m) above the roof AND at least 2 ft (.61 m) above any portion of roof within 10 ft (3.05 m) as shown in Figure 8.10.
- The distance required between caps is shown in Figure 8.10.



### Multiple Chimney Locations

A	B
6 in. (minimum) up to 20 in. 152 mm/508 mm	18 in. minimum 457 mm
20 in. and over	0 in. minimum

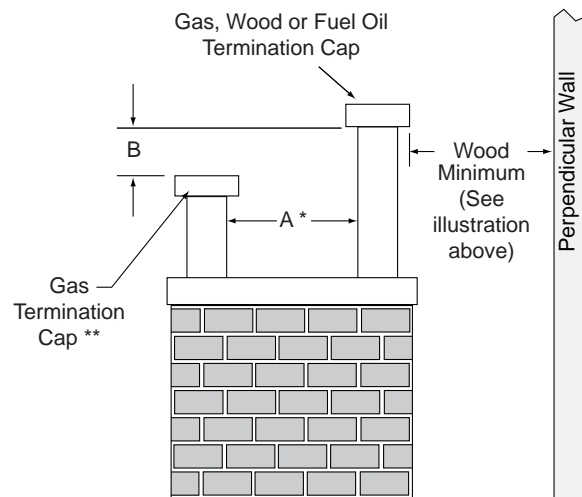

\* If using decorative cap cover(s), this distance may need to be increased. Refer to the installation instructions supplied with the decorative cap cover.

\*\* In a staggered installation with both gas and wood terminations, the wood termination cap must be higher than the gas termination cap.

Figure 8.10 Multiple Chimney Locations

# 9 Chase Installations

## A. Construct the Chase

A chase is a vertical boxlike structure built to enclose the fireplace and/or its vent system. Vertical chimneys that run on the outside of a building must be installed inside a chase.

Construction of the chase may vary with the type of building. These instructions are not substitutes for the requirements of local building codes. Local building codes **MUST** be checked.

A chase should be constructed in the manner of all outside walls of the home to prevent cold air drafting problems. The chase should not break the outside building envelope in any manner. All outer walls need to be insulated.

Building codes require false ceiling and ceiling firestops at each floor of the chase or every 10 ft (3.05 m) of clear space to control spread of fire.

Walls, ceiling, base plate and cantilever floor at the first level of the chase should be insulated. See Figure 9.1. Vapor and air infiltration barriers should be installed in the chase as per regional codes for the rest of the home. Additionally, Hearth & Home Technologies recommends that the inside surfaces be sheet rocked and taped (or the use of an equivalent method) for maximum air tightness.

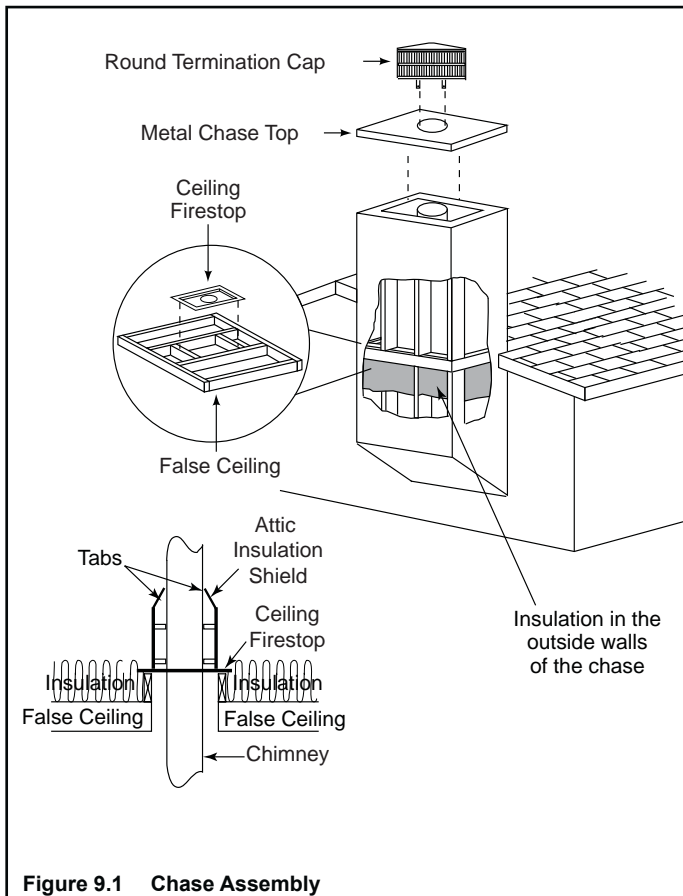

Figure 9.1 Chase Assembly

Gas line holes and other openings should be caulked with high temperature caulk or stuffed with unfaced fiberglass insulation. If the fireplace is being installed on a cement slab, we recommend that in cold climates, a sheet of plywood or other raised platform be placed underneath to prevent conducting cold up into the room.

Three examples of chase applications are shown in Figure 9.2.

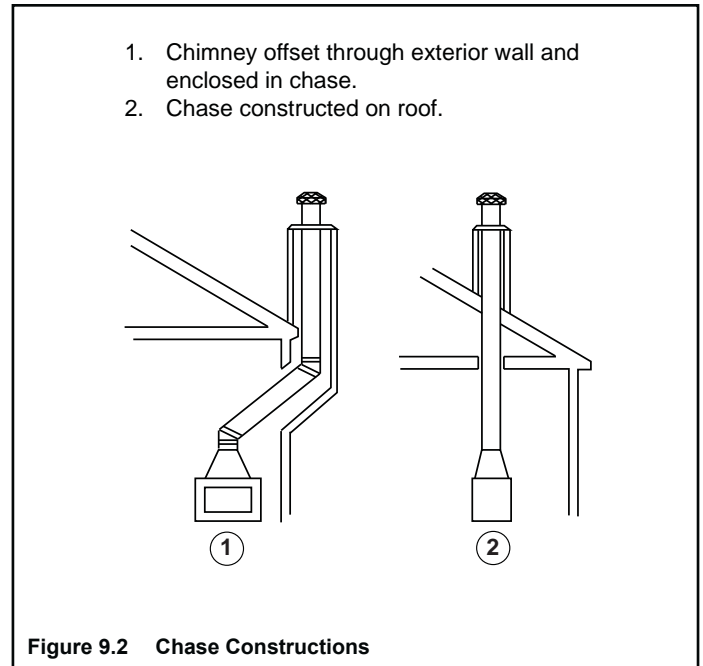

Figure 9.2 Chase Constructions

**WARNING!** You must install false ceilings and ceiling firestops at each floor of the chase or every 10 ft (3.05 m) to control spread of fire.

**WARNING! Risk of Fire! DO NOT** seal area between fire stop opening and chimney pipe. Restricting air flow around chimney may cause fire.

**WARNING! Risk of Fire!** You must maintain a minimum 2 in. (51 mm) air space clearance to insulation and other materials surrounding the chimney system.

- Insulation and other materials must be firmly secured to prevent accidental contact with chimney system.
- The chase must be properly blocked to prevent blown insulation or other combustibles from entering and making contact with fireplace or chimney.
- Failure to prevent contact between insulation or other materials and chimney system may cause overheating and fire.



## B. Install Fireplace & Chimney

Install as per Sections 7 and 8.

## C. Install Chase Top

- You **MUST** use a chase top in a chase installation. Chase tops are available from your Heat & Glo dealer or may be field constructed.
- Include a turndown and drip edge to prevent water from seeping into the chase.
- Include a 2 in. (51 mm) soldered, caulked or spun collar around pipe opening to keep water out.
- Provide a 1/8 in. (3 mm) gap around the flue pipe.
- Slope the chase top downward away from the opening.

**CAUTION! DO NOT** caulk the pipe to the chase top collar.

- Caulk all seams to prevent leaks.
- Refer to Figure 9.4.

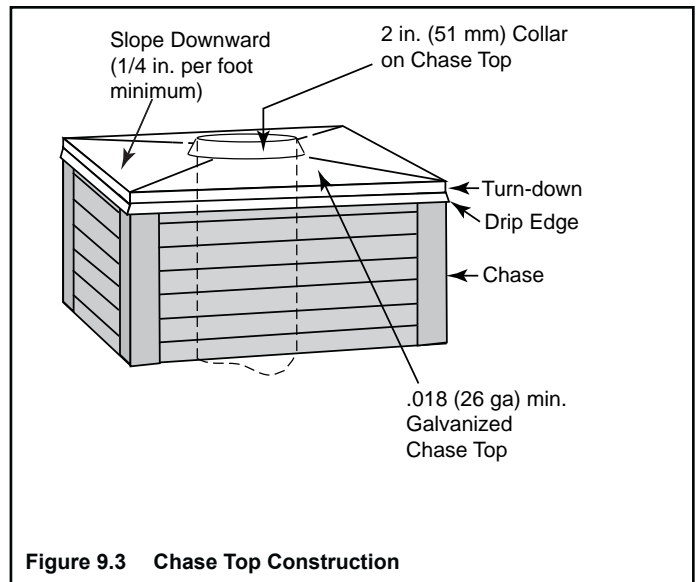

## D. Install Termination Cap

Install the chimney sections up through the chase enclosure.

- Refer to termination cap instructions.

**WARNING! Risk of Fire!** The minimum overlap of cap to pipe (as shown in the following illustrations) **MUST** be met or chimney may separate from cap. Separation allows sparks, heat and embers to escape.

**NOTICE:** Paint the termination cap with a rust-resistant paint to protect against the effects of corrosion on those parts exposed to the weather.

- TR11 Round Termination Cap

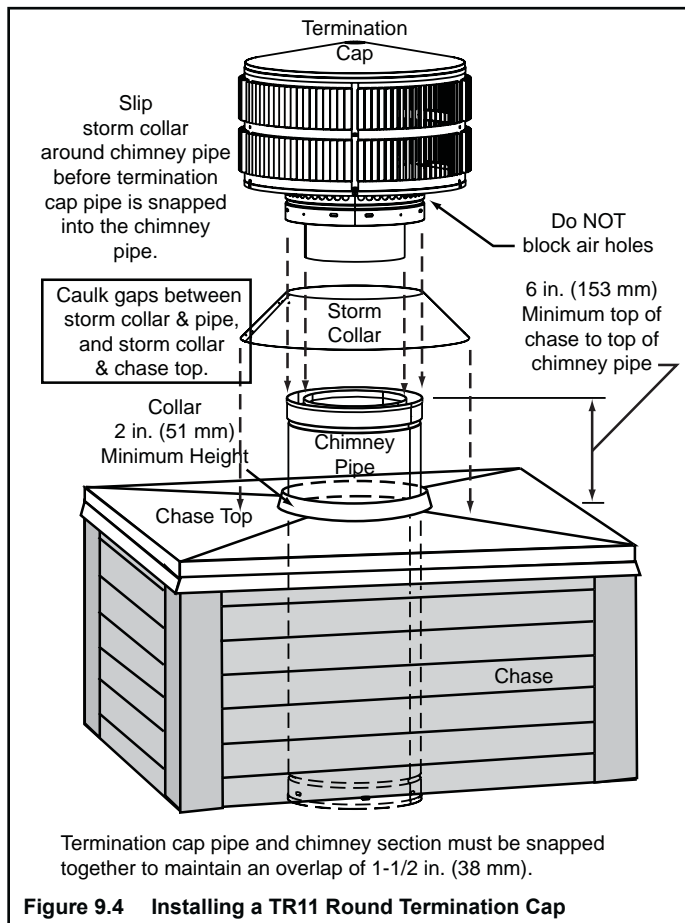

- TR11T Round Telescoping Termination Cap

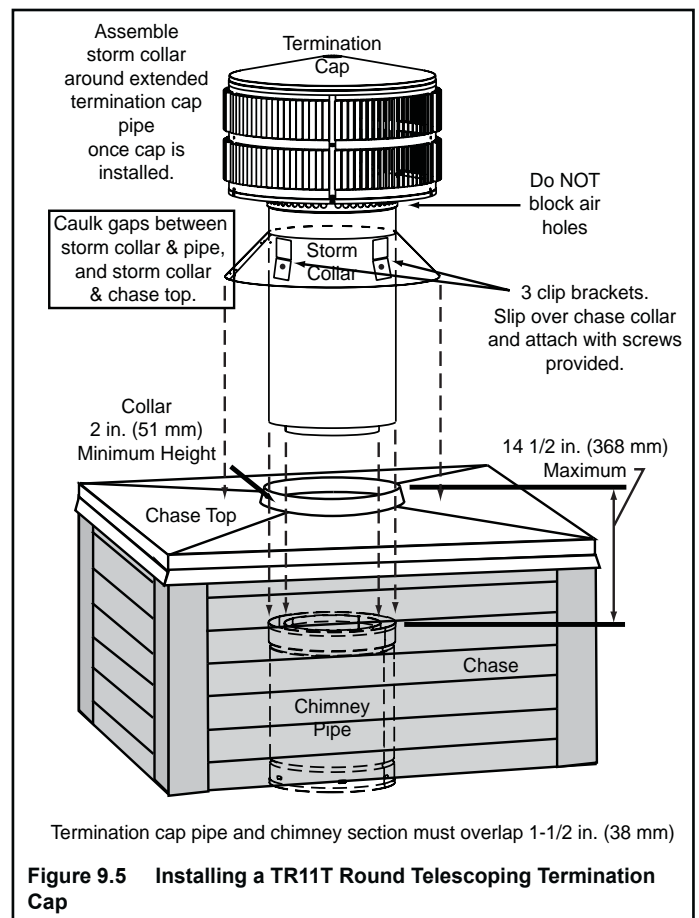

- ST1175 Square Termination Cap

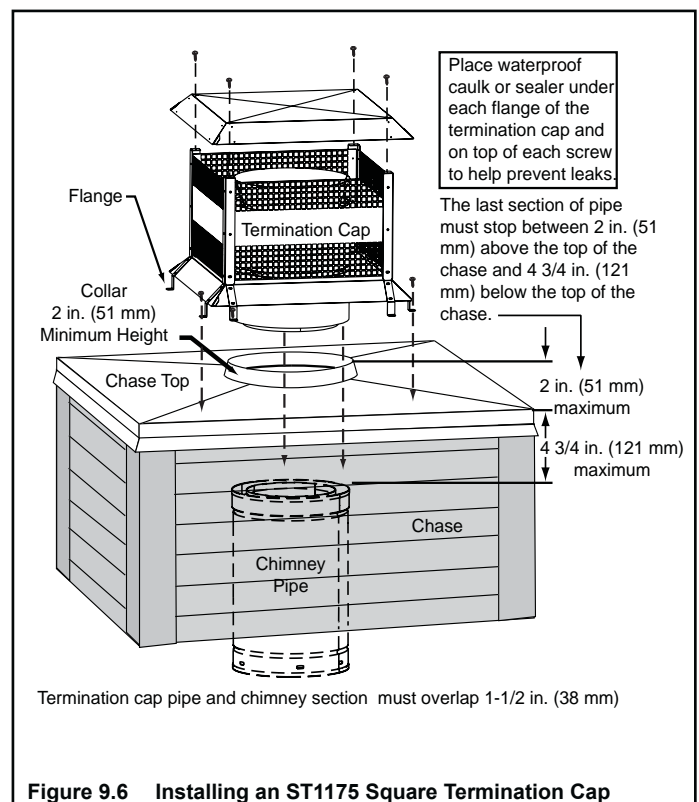

- TCT1175 Terra Cotta Cap

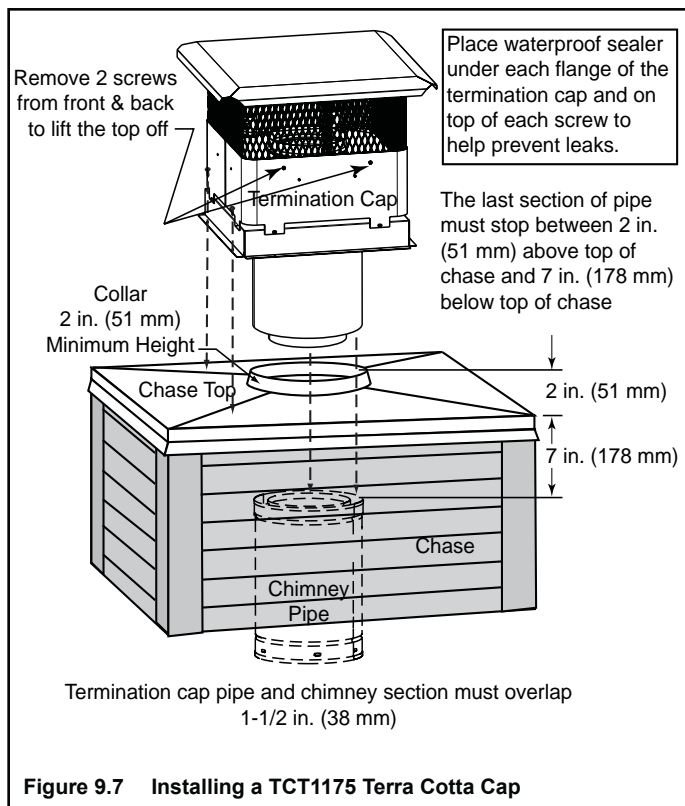

# 10 Shrouds

## A. Radiation Shield

- Some shrouds require a radiation shield. Use where specified.
- Radiation shield must be constructed of minimum 26 ga sheet metal.

## B. Field Constructed Shrouds

**WARNING! Risk of Fire!** Shrouds must be constructed as specified. Improper construction may overheat chase top.

- Chase top shrouds may be field constructed where permitted by regional building codes.

**NOTICE:** Some regional codes require an agency-Listed shroud. Consult your local building officials.

- Hearth & Home Technologies supplies UL listed shrouds. See your dealer for details.
- The following field constructed shroud designs have been tested for Hearth Technologies fireplace systems and termination caps.
- The shrouds must be constructed from a minimum .018 in. (26 ga) thick aluminized steel.

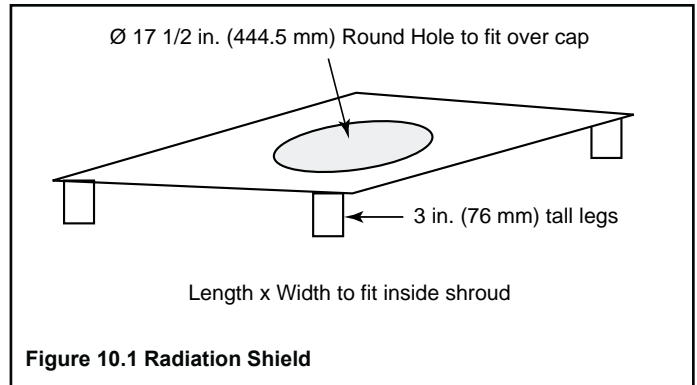

Figure 10.1 Radiation Shield

- The wire mesh is optional but recommended and must be .018 in. thick minimum, 1/2 in. mesh.

## Open Top Shroud (TR11/TR11T caps require radiation shield)

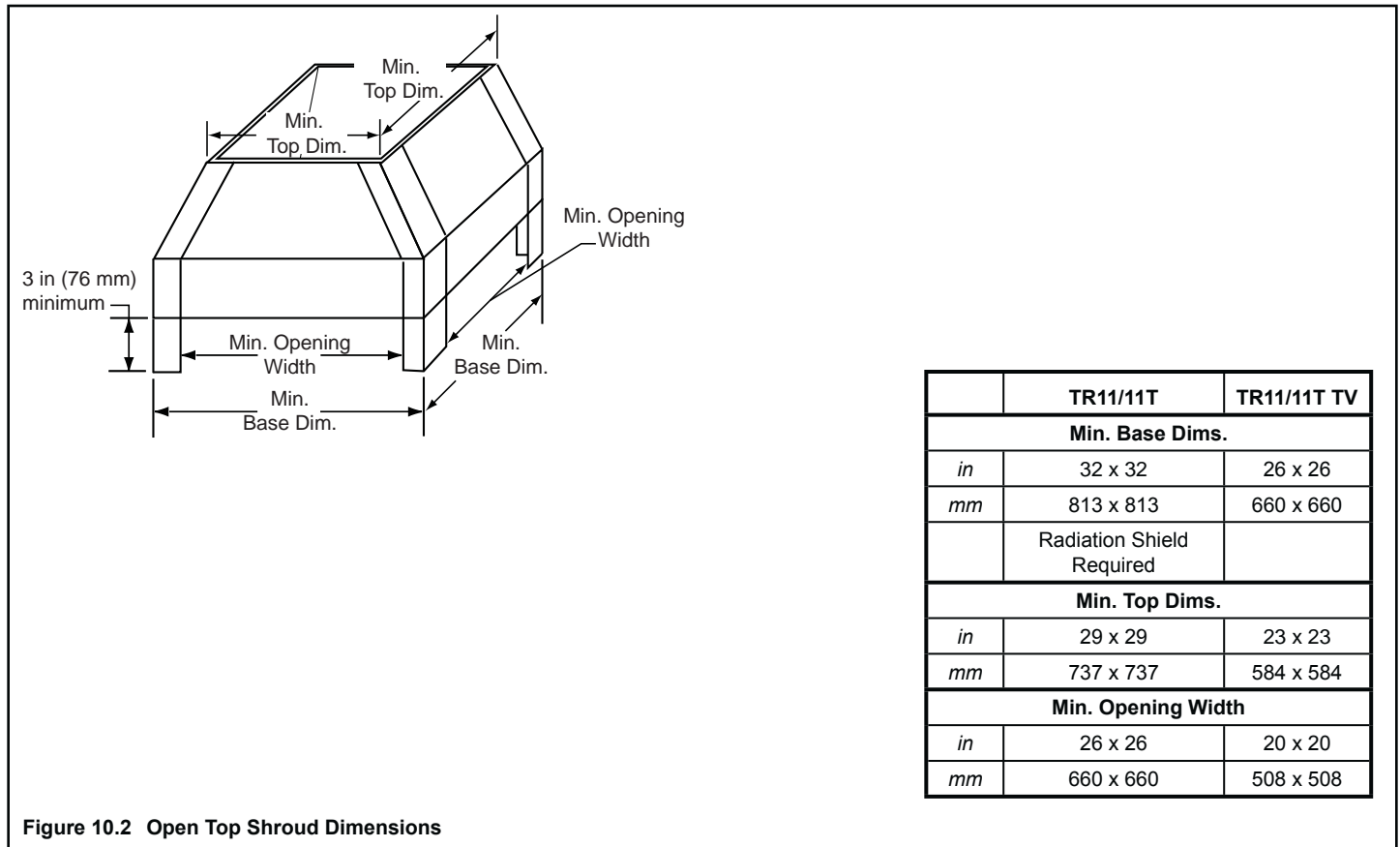

Figure 10.2 Open Top Shroud Dimensions

### Mailbox Style Shroud (radiation shield required)

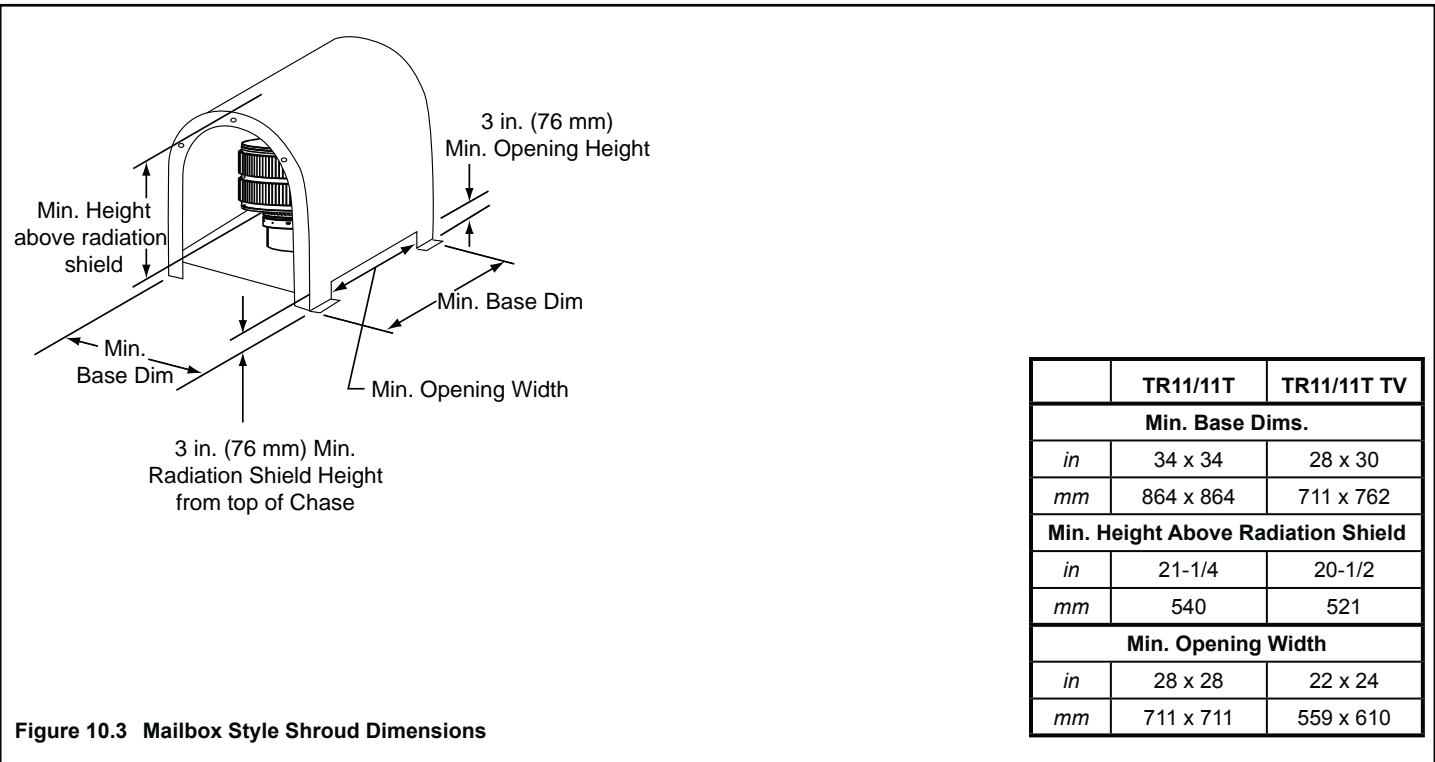

Figure 10.3 Mailbox Style Shroud Dimensions

### Roofed Style Shroud (radiation shield required)

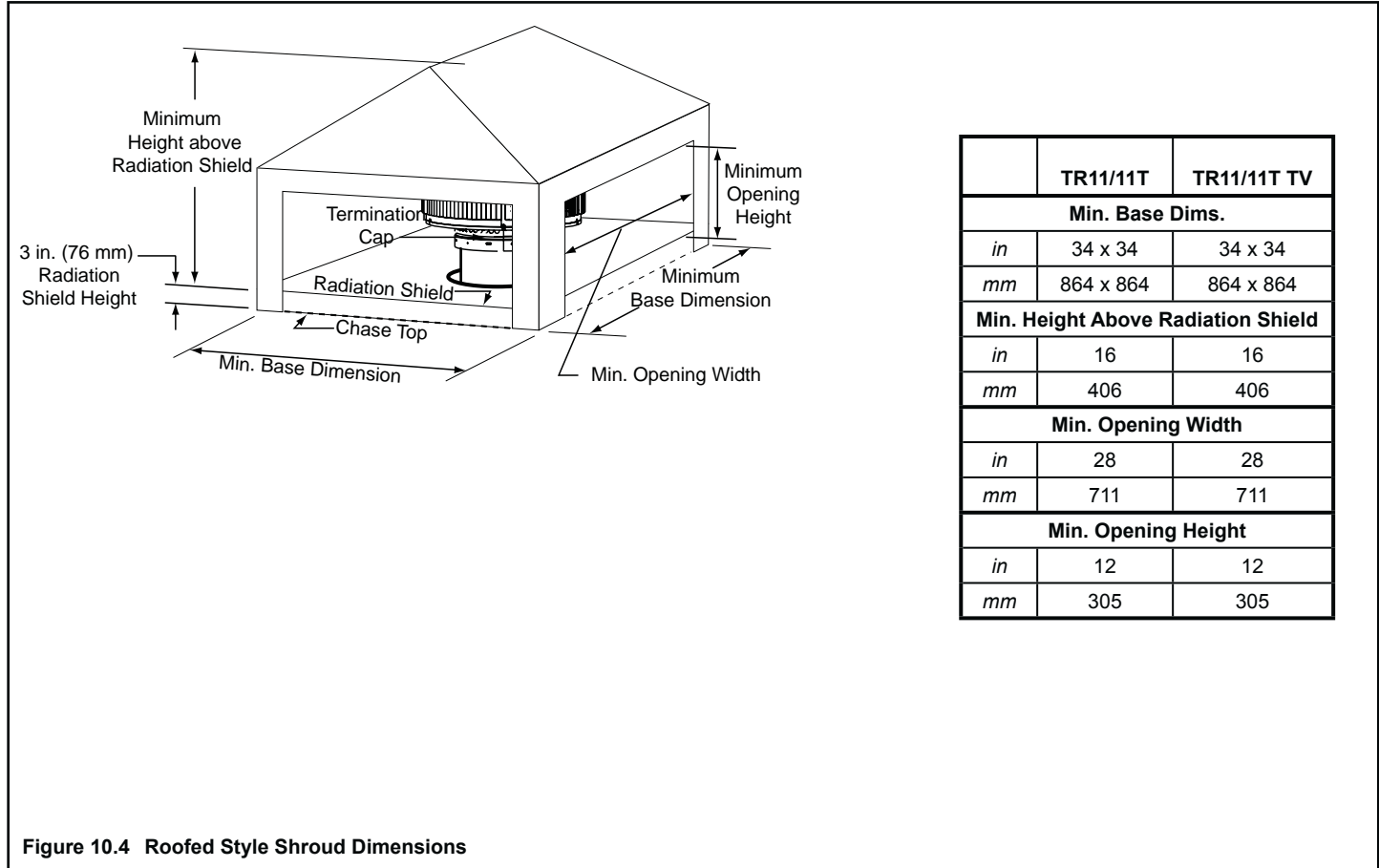

Figure 10.4 Roofed Style Shroud Dimensions

# 11 Finishing

## A. Non-Combustible Materials

- Materials which will not ignite and burn, composed of any combination of the following:
  - Steel                    - Iron
  - Brick                    - Tile
  - Concrete               - Slate
  - Glass                    - Plasters
- Materials reported as passing **ASTM E 136, Standard Test Method for Behavior of Metals, in a Vertical Tube Furnace at 750° C**

## B. Combustible Materials

- Materials made of or surfaced with any of the following materials:
  - Wood                    - Compressed paper
  - Plant fibers           - Plastic
- Any material that can ignite and burn; flame proofed or not, plastered or un-plastered

## C. Hearth Extension

**WARNING! Risk of fire!** High temperatures, sparks, embers or other burning material falling from the fireplace may ignite flooring or concealed combustible surfaces.

- Protective metal hearth strips **MUST** be installed.
- Hearth extensions **MUST** be installed exactly as specified.
- You **MUST** use a hearth extension with this fireplace.
- This fireplace has been tested and approved for use with a hearth extension insulated to a minimum R value of 1.03.
- The hearth extension material **MUST** be covered with tile, stone or other non-combustible material.
- Manufactured hearth materials will usually have a published **R value** (resistance to heat) or **k value** (conductivity of heat). Refer to the formula in Table 11.1 to convert a k value to an R value,
- Refer to Table 11.2 for hearth extension insulation alternatives.

Table 11.1

<b><math>R = 1/k \times \text{inches of thickness}</math></b>
---

Table 11.2

<b>Hearth Extension Insulation Alternatives-Total minimum R Value must equal 1.03</b>			
<b>Material</b>	<b>k per inch thick</b>	<b>r per inch thick</b>	<b>Minimum thickness required</b>
Hearth & Home HX3, HX4 (Micore 300™)	0.49	2.06	1/2 in.
USG Micore 160™	0.39	2.54	1/2 in.
USG Durock™ Cement Board	1.92	0.52	2 in.
Cement Mortar	5.0	0.20	5-1/8 in.
Common Brick	5.0	0.20	5-1/8 in.
Ceramic Tile	12.50	0.08	12-1/4 in.
Armstrong™ Privacy Guard Plus	0.46	2.18	1/2 in.
Marble	14.3-20.0	0.07-0.05	14-5/8 in. - 20-3/8 in.

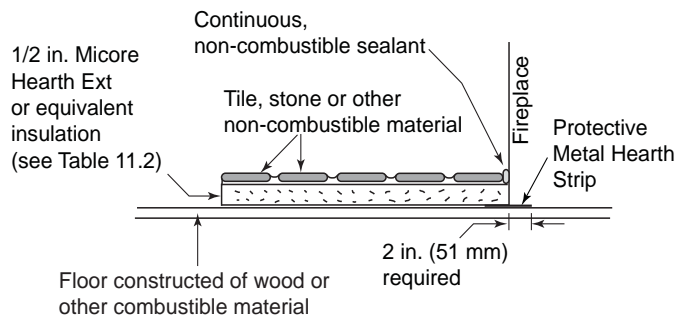
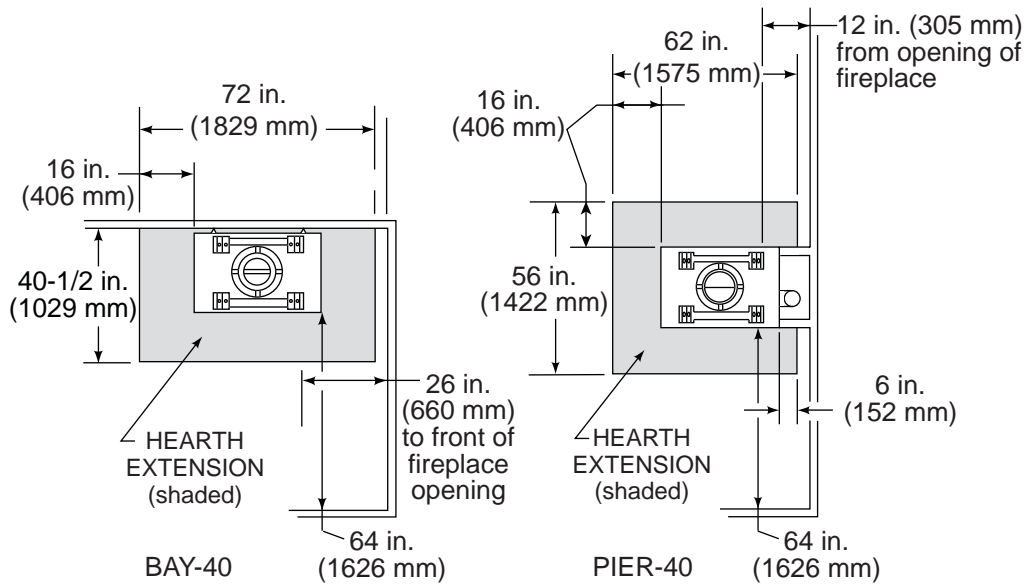

Figure 11.1 Hearth Extension Dimensions

## D. Finishing Material

Refer to Sections 11.A. and Sections 11.B. for combustible/non-combustible materials. Refer to Figure 11.2 for non-combustible zone.

**WARNING! Risk of Fire!** You must maintain clearances.

- Use only non-combustible framing material below standoffs.
- Sheetrock, wood or other combustibles must NOT be used as sheathing or facing in the non-combustible zone.
- **DO NOT** cover metal fireplace front with combustible materials.
- Install combustible materials only to specified clearances on top front and side edges.
- Complete framing and apply facing material (drywall) over framing.
- A bead of 300-deg F minimum non-combustible sealant must be used to close off any gaps at the top and sides between the fireplace and facing to prevent cold air leaks.
- Large gaps can be bridged with fiberglass rope gasket.
- Only non-combustible materials may be used to cover the metal fireplace front.

The metal surfaces of the fireplace may be covered with non-combustible materials only.

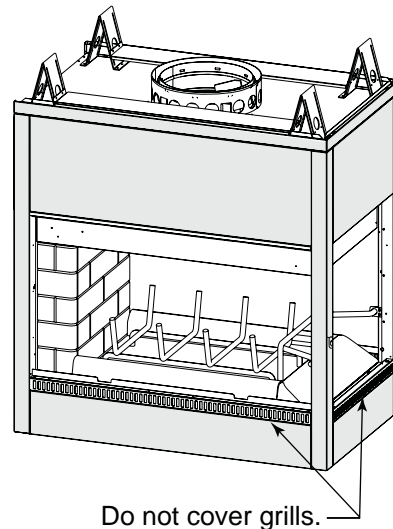

Figure 11.2 Non-combustible Materials Zone

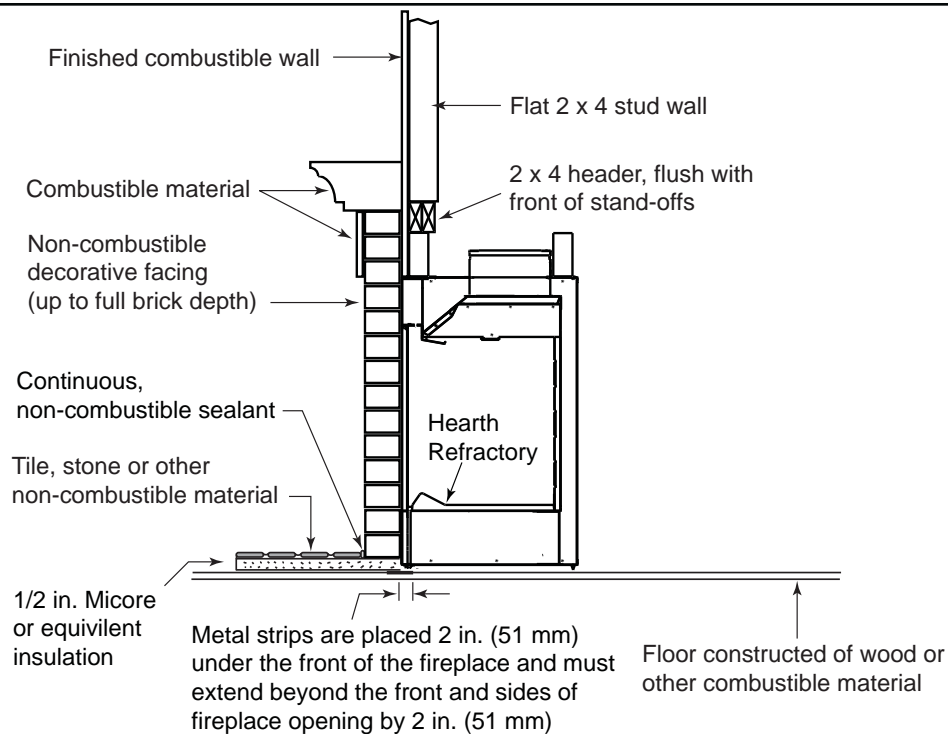
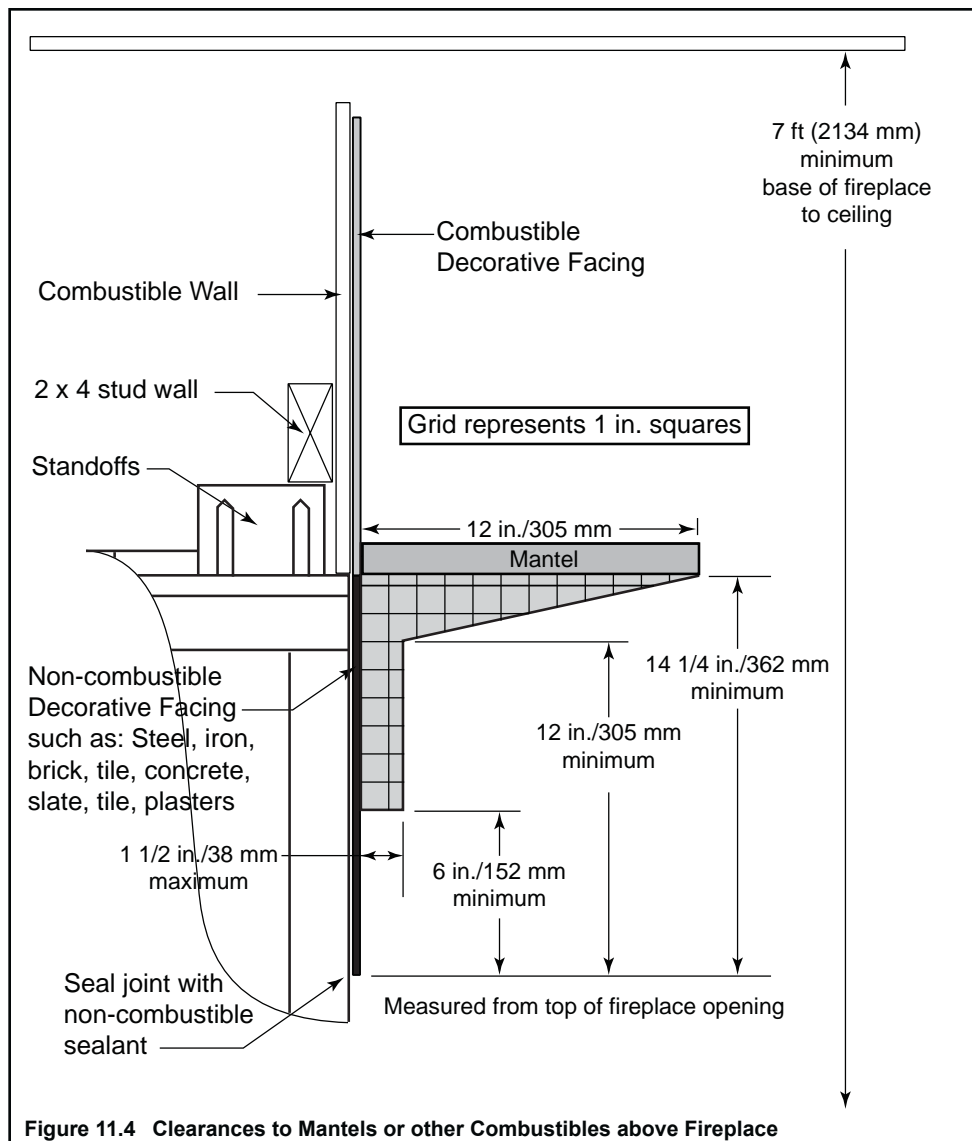

Figure 11.3 Decorative Facing



## E. Combustible Mantel

- Refer to shaded areas of Figure 11.4 for locations and dimensions of a combustible mantel.
- A combustible mantel may be positioned no lower than 14 1/4 in. (362 mm) above the top of the fireplace opening.
- A combustible mantel may have a maximum depth of 12 in. (305 mm).
- Combustible trim and materials cannot be placed within 6 in. (152mm) of the fireplace opening (top or sides).
- Combustible materials projecting more than 1 1/2 in. (38 mm) shall not be placed within 12 in. (305 mm) from the top of the fireplace opening.
- Combustible trim must not cover the metal surfaces of the fireplace.
- Mantel clearance is in accordance with **Section 7-3.3.3 of ANSI/NFPA211.**



## F. Sidewalls/Surrounds

- Adjacent combustible sidewalls must be located a minimum of 12 in. (305 mm) from the fireplace opening.
- Combustible or non-combustible mantel legs, surrounds and stub walls may be constructed per Figure 11.5.

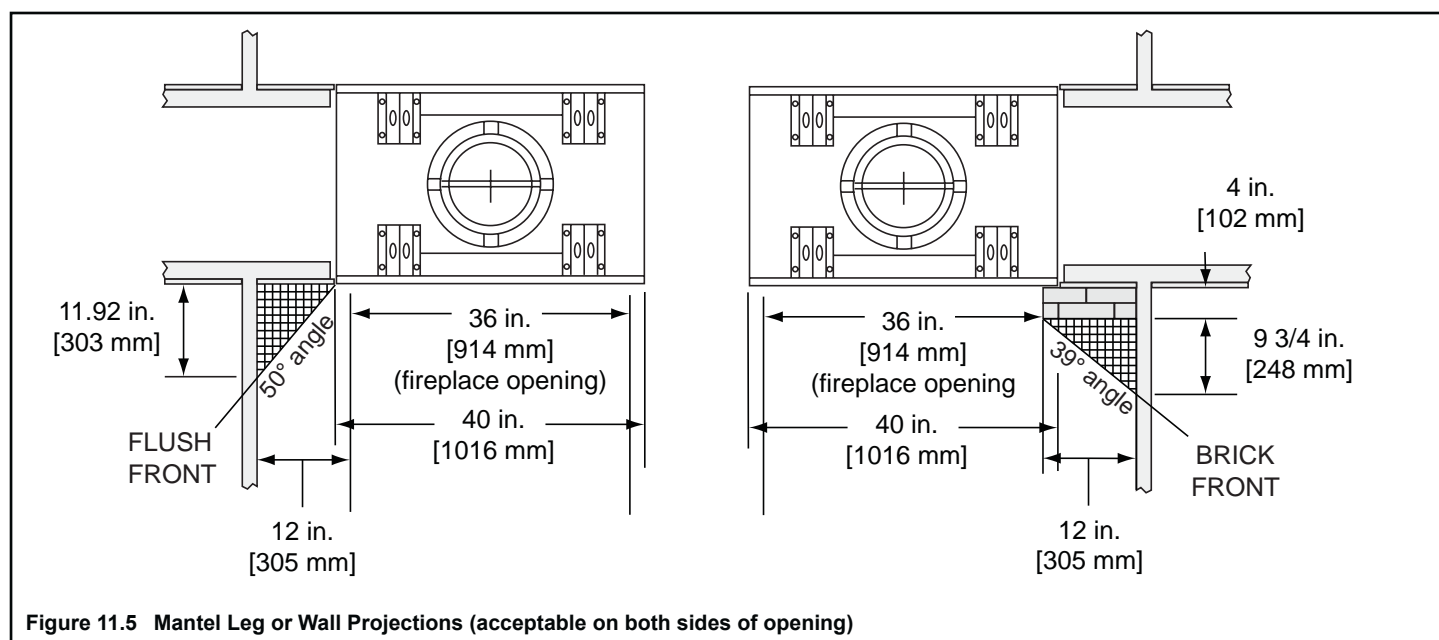

# 12 Accessories

## A. Gas Log/Lighter Provision

**WARNING! Fire and/or Asphyxiation Risk!** Use with solid wood fuel or decorative gas appliance only. Gas fire generates fumes.

- **DO NOT** install unvented gas logs
- Damper must be locked fully open when gas logs are installed

A certified gas log lighter or decorative gas log set can be installed in this fireplace.

- Maximum input is 100,000 BTU/hr.
- Decorative gas appliance must be certified to **ANSI Z21.60** "Standard for Decorative Gas Appliances for Installation in Vented Fireplaces".
- Must be installed in accordance with the **National Fuel Gas Code, ANSI Z223.1**.
- A gas log set must incorporate a gas shutoff.
- Gas Log set requires the damper to be locked fully open.
- A listed automatic damper system with safety interlock may be used in this fireplace with only compatible, listed gas log sets. See damper system manufacturer's instructions.
- Knockouts are provided on both sides of the fireplace and in refractories for 1/2 in. (13 mm) iron pipe.
- Seal refractory around pipe with fireplace mortar or a non-combustible sealant.

## B. Wood Burning Inserts

**WARNING! Risk of Fire!** Improper installation of wood inserts may cause fireplace or chimney system to overheat.

If a wood burning insert is being installed in this fireplace, Hearth & Home Technologies recommends full reline of the chimney.

- Cooling air openings at the top of the chimney must not be obstructed in any manner.
- Hearth & Home Technologies recommends securing the reline at the top of the flue and using the cap certified for use with this fireplace system.

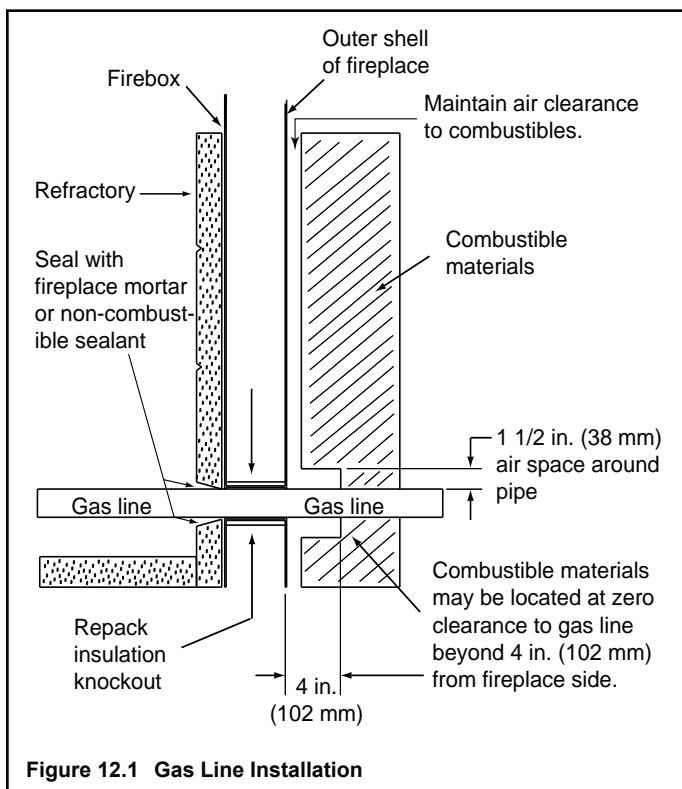

# 13 Reference Materials

## A. Fireplace Dimensions

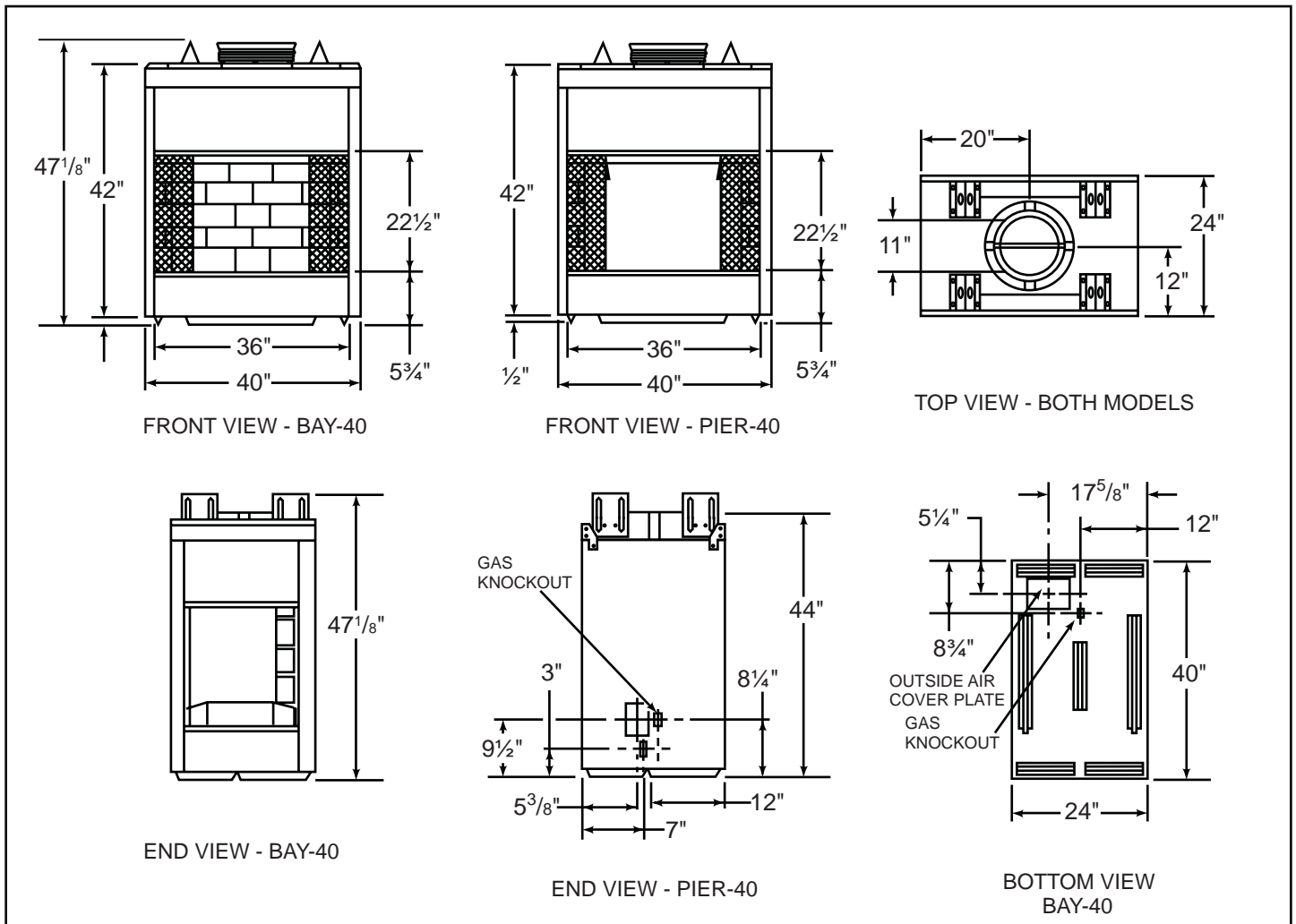

## B. Optional Components

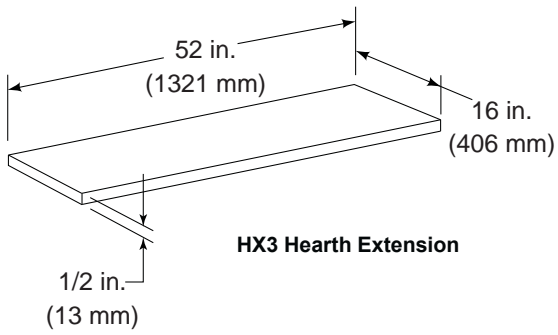

**HX3 Hearth Extension**

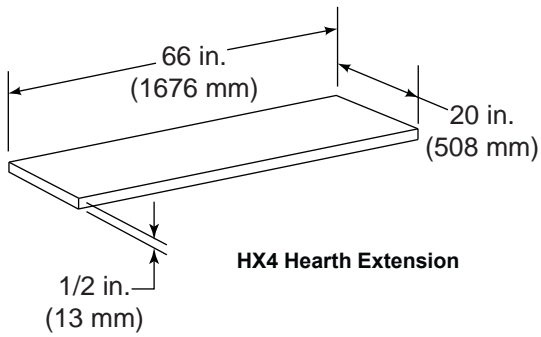

**HX4 Hearth Extension**

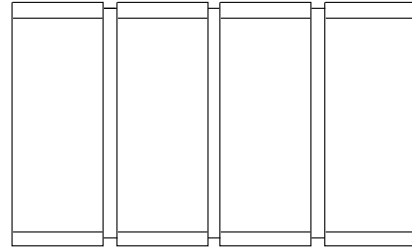

**DM1036 Bi-fold Glass Doors**

- ➔ (BAY-40 requires 1 DM1036 door)
- ➔ (PIER-40 requires 2 DM1036 doors)

**DM1000 Bi-fold Glass Doors**

- ➔ (BAY-40 requires 2 DM1000 doors)
- ➔ (PIER-40 requires 1 DM1000 door)

***See your Heat & Glo dealer for a complete listing of optional components.***

## C. Chimney Components

The following pictures show only those chimney components which may be safely used with this fireplace.

Catalog #	Description
CAK5A	Chimney Air Kit
ID4	Insulated Duct/Outside Air
UD4	Uninsulated Duct/Outside Air
SL1106	Chimney Section - 6 in. (152 mm) long
SL1112	Chimney Section - 12 in. (305 mm) long
SL1118	Chimney Section - 18 in. (457 mm) long
SL1136	Chimney Section - 36 in. (914 mm) long
SL1148	Chimney Section - 48 in. (1219 mm) long
SL11	Chimney Stabilizer
SL1130	Chimney Offset/Return - 30 deg
FS538	Ceiling Firestop - Straight
FS540	Ceiling Firestop - 30 deg
AS10	SL1100 Straight Attic Insulation Shield, 24 in. (610 mm)
JB577	Chimney Joint Band
CB576	Chimney Bracket
RF570	Roof Flashing - Flat to 6/12 Pitch
RF571	Roof Flashing - 6/12 to 12/12 Pitch
TR11	Round Termination Cap
TR11T	Round Telescoping Termination Cap
TCT1175	Terra Cotta Termination Cap
ST1175	Square Termination Cap
CT56	Chase Top
DTO134	Short Octagon Decorative Cap
DTO146	Tall Octagon Decorative Cap
DTS134	Short Square Decorative Cap
DTS146	Tall Square Decorative Cap
LDS33	Decorative Shroud - 3 ft x 3 ft (.91 m x .91 m)
LDS46	Decorative Shroud - 4 ft x 6 ft (1.22 m x 1.83 m)
LDS-BV	Decorative Shroud - 26 in. x 26 in. (660 mm x 660 mm)
	Field Constructed Shrouds (See "Woodburning Termination Cap")
CT-11A	Adapter - May be used with the following Copper Caps
	CT-Series
	DT-Series

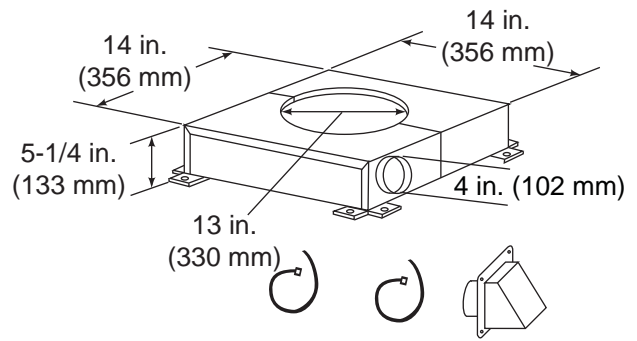

ID4 Insulated Duct CAK5A Chimney Air Kit

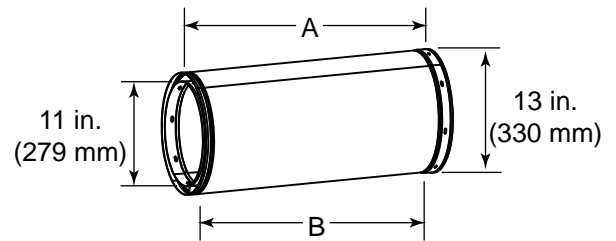
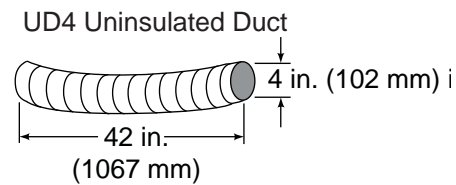
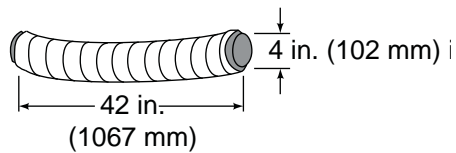

Chimney Sections

Catalog #	A		B	
	in	mm	in	mm
SL1106	6	152	4-3/4	121
SL1112	12	305	10-3/4	273
SL1118	18	457	16-3/4	425
SL1136	36	914	34-3/4	883
SL1148	48	1219	46-3/4	1187

A = Actual Length

B = Effective Length (length of chimney part after it has been snapped to another)

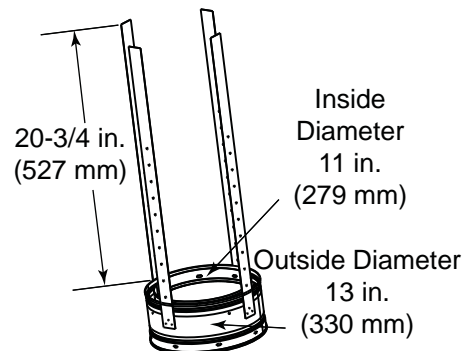

SL11 Vent Stabilizer

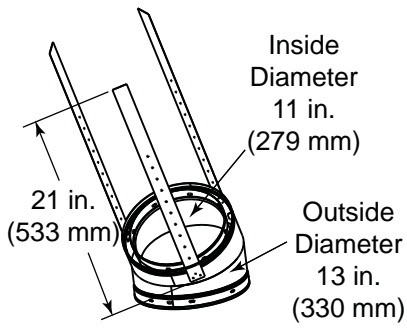

**SL1130 Offset/Return**

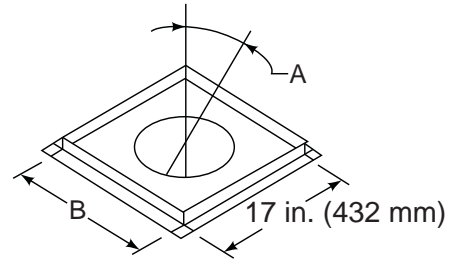

Catalog #	A	B	
FS538	0-deg.	17 in.	432 mm
FS540	30-deg.	26 in.	660 mm

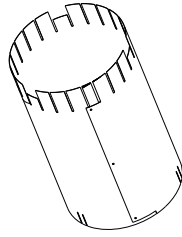

**Assembled**  
Diameter: 17 in./432 mm  
Height: 24 in./610 mm

**AS10 Straight Attic Insulation Shield**

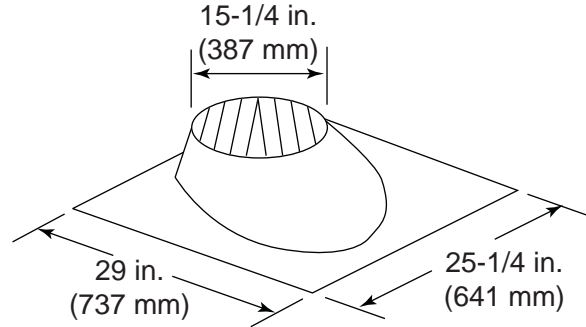

**RF570 Roof Flashing**

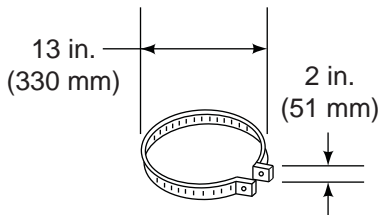

**JB577 Chimney Joint Band**

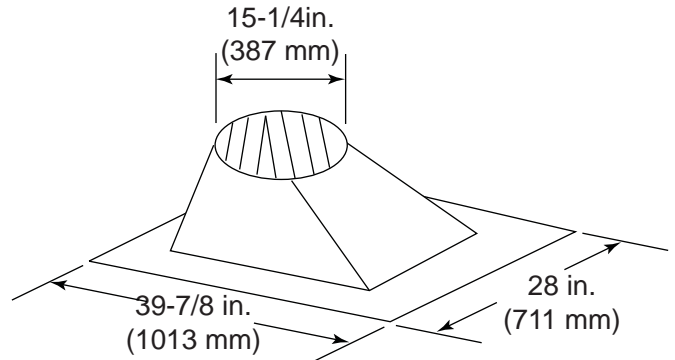

**RF571 Roof Flashing**

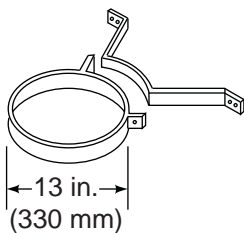

**CB576 Chimney Joint Band**

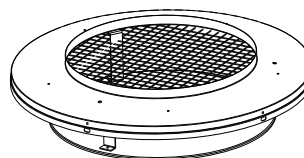

**TR-TVK**  
**TR Top Vent Kit**

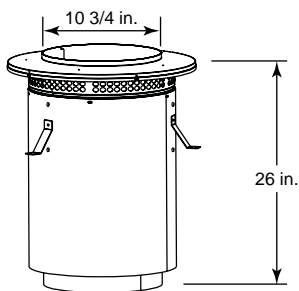

**CT-11A**

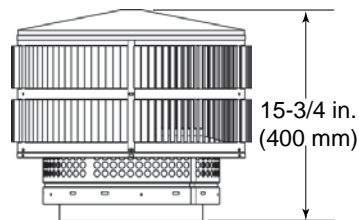

**TR11 - Round Termination Cap**

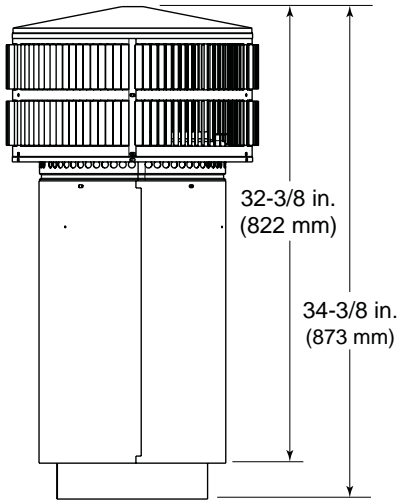

**TR11T - Round Telescoping Termination Cap**

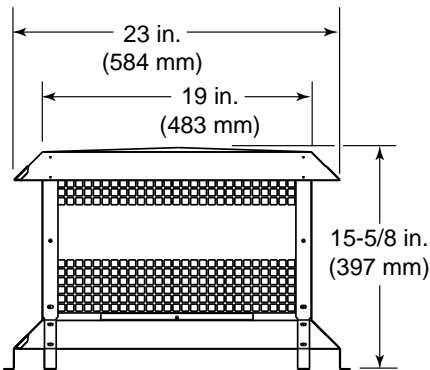

**ST1175/ - Square Termination Cap**

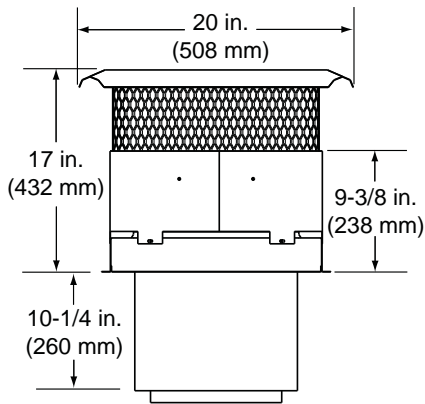

**TCT1175 - Terra Cotta Cap**

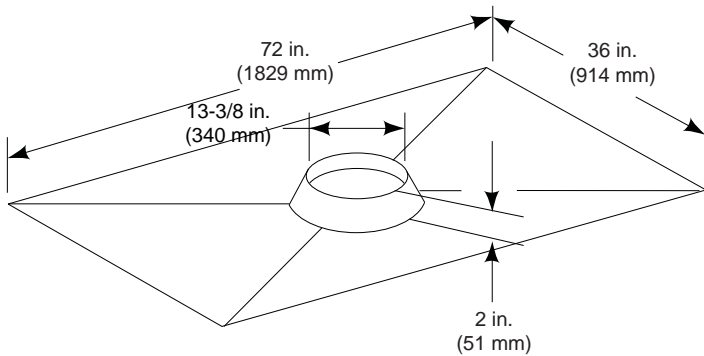

**CT56 Chase Top**

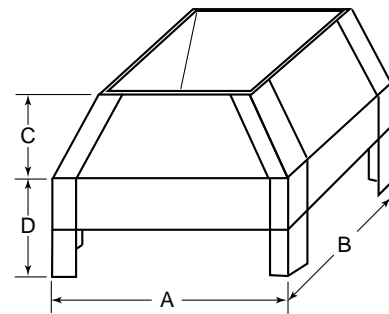

**LDS33/LDS46 Decorative Shroud**

Catalog #	A		B		C		D	
	in.	mm	in.	mm	in.	mm	in.	mm
LDS33	36	914	36	914	8.5	216	11	279
LDS46	48	1219	72	1829	8.5	216	11	279

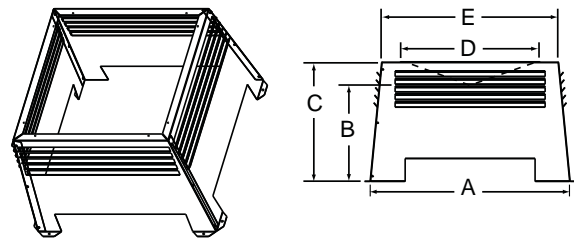

**LDS-BV Decorative Shroud**

Catalog #	A	B	C	E	E
	in.	mm	mm	mm	mm
LDS-BV	26	12.5	15.5	22	23
	660	318	394	533	584

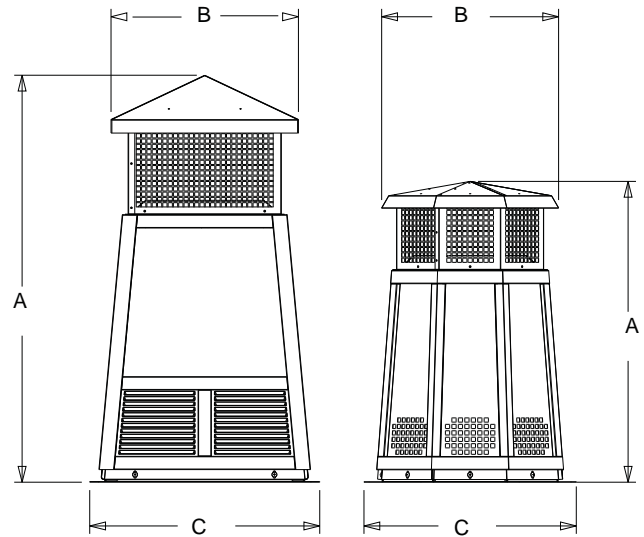

**DTS134 /DTS146    DTO134 / DTO146  
Decorative Caps**

	A	B	C
DTO134			
in	34	20	24
mm	864	508	610
DTO146			
in	46	22.7	26
mm	1168	576	660
DTS134			
in	34	21.18	24
mm	864	538	610
DTS146			
in	46	21.18	26
mm	1168	538	660

E. Contact Information



No one builds a better fire

Please contact your Heat & Glo dealer with any questions or concerns.

For the number of your nearest Heat & Glo dealer, please visit [www.heatnglo.com](http://www.heatnglo.com).

– NOTES –

---

---

---

---

---

---

---

---

---

---

**CAUTION**

**DO NOT DISCARD THIS MANUAL**



- Important operating and maintenance instructions included.
- Read, understand and follow these instructions for safe installation and operation.
- Leave this manual with party responsible for use and operation.

