

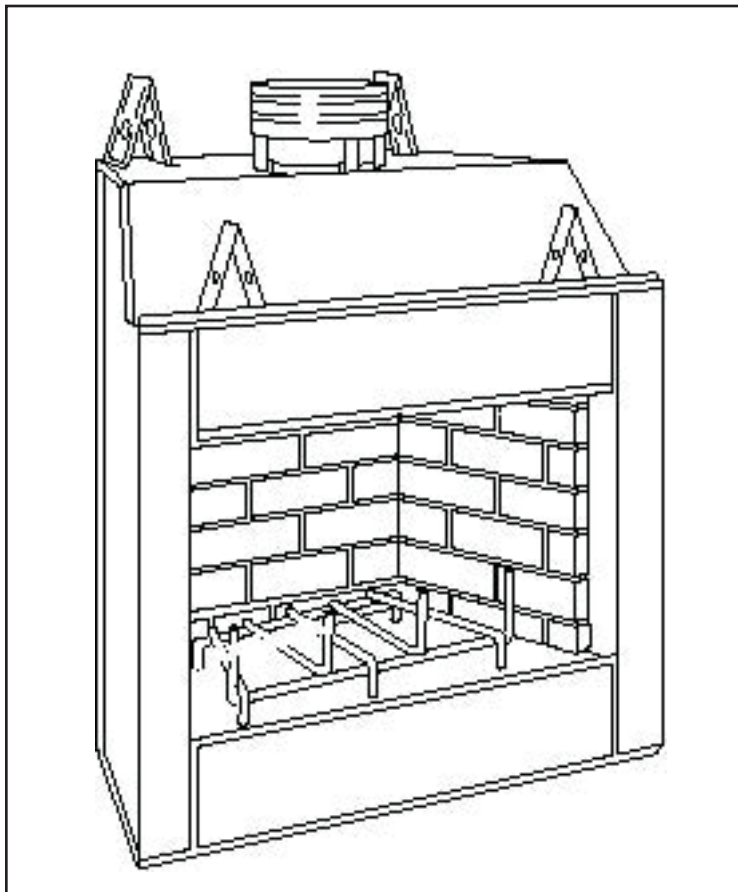

# HEAT-N-GLO

This appliance has been retired.  
Service parts pages within have been removed.  
For replacement parts, please refer to the individual  
service parts list located on the brand websites.

## RHW-44 WOODBURNING FIREPLACE INSTALLATION & OPERATING INSTRUCTIONS FOR RESIDENTIAL USE



**Plumber:** Please refer to page 18 for gas connection information.



**Framer:** Please refer to page 9 for framing specifications.

**PLEASE RETAIN THIS MANUAL FOR FUTURE REFERENCE.**

**Table of Contents**

**A. Listings and Code Approvals.....3**  
**B. Description of the Fireplace System.....3**  
**C. Fireplace System Components.....4**  
**D. Pre-Installation Preparation .....8**  
    1. Fireplace Locations and Space Requirements.....8  
    2. Framing The Fireplace .....9  
    3. Hearth Extensions.....10  
    4. Sidewalls/Surrounds.....11  
    5. Mantel.....11  
**E. Chimney Requirements .....11**  
    1. Using Offsets and Returns .....11  
    2. Chimney Height Requirements .....13  
    3. Determining the Number of Chimney Sections Required.....13  
**F. Step-By-Step Installation of the Fireplace System.....14**  
**G. Constructing a Chase.....19**  
    1. Materials For The Chase.....19  
    2. Installing a Terminal Cap on a Chase-Enclosed Chimney .....20  
**H. Operating Instructions.....20**

**Safety Precautions:**

1. Please read these installation instructions completely before beginning installation procedures. Failure to follow them could cause a fireplace malfunction resulting in serious injury and/or property damage.
2. Always check your Local Building Codes prior to installation. The installation must comply with all Local, Regional, State and National Codes and regulations.
3. An adequate supply of replacement combustion air from outside the house must be available to the fire for the fireplace to operate properly. To achieve this, an optional outside air kit is highly recommended.  
  
 In the event the home is unusually tight, the optional combustion air kit may not provide all the air required to support combustion. Heat-N-Glo is not responsible for any smoking or related problems that may result from the lack of adequate combustion air. It is the responsibility of the builder/contractor to ensure that adequate combustion air has been provided for the fireplace.
4. The RHW-44 woodburning fireplace must be installed with the Hearth Technologies Inc. (HTI) SL300 Series chimney system.  
  
 The chimney system must always terminate outside the building. Be sure to follow all chimney specifications given in these installation instructions.
5. **NEVER** leave children unattended when there is a fire burning in the fireplace.
6. This fireplace is built for solid fuel only. **NEVER** use gasoline, gasoline type lantern fuel, kerosene, charcoal lighter fluid, or similar liquids in this fireplace. Keep any flammable liquids a safe distance from the fireplace.
7. **DO NOT** use chimney cleaners or flame colorants in your fireplace.
8. The flue damper must be open at all times when the fireplace is in use.
9. While servicing this fireplace, always shut off any electricity or gas to the fireplace. This will prevent possible electrical shock or burns. Also, make sure the unit is completely cooled before servicing.
10. To ensure a safe fireplace system and to prevent the buildup of soot and creosote, inspect and clean the fireplace and chimney prior to use and periodically during the burning season.

## A. LISTINGS AND CODE APPROVALS

The RHW-44 fireplace system has been tested and listed in accordance with UL 127 and ULC S610 Standards, and has been listed by Underwriters Laboratories Inc. for installation and operation in the United States and Canada as described in these Installation & Operating Instructions.

The model RHW-44 fireplace has been tested and listed for use with the components listed below. The optional components may be purchased separately and installed at a later date. However, installation of

an outside air kit will require significant reconstruction, and should be installed at the time of the initial fireplace installation.

Check with your Local Building Code Agency prior to installing this fireplace to ensure compliance with local Codes, including the need for Permits and follow up inspections. If any assistance is required during installation, please contact your local dealer or the Heat-N-Glo Technical Services Department, 20802 Kensington Blvd., Lakeville, MN 55044.

### WARNING!

**THIS HEAT-N-GLO FIREPLACE AND ITS COMPONENTS ARE DESIGNED TO BE INSTALLED AND OPERATED AS A SYSTEM. ANY ALTERATION TO OR SUBSTITUTION FOR ITEMS IN THIS SYSTEM, UNLESS ALLOWED BY THESE INSTALLATION INSTRUCTIONS, WILL VOID THE UNDERWRITERS LABORATORIES LISTING AND MAY VOID THE PRODUCT WARRANTY. IT MAY ALSO CREATE A HAZARDOUS INSTALLATION. READ THROUGH THESE INSTRUCTIONS THOROUGHLY BEFORE STARTING YOUR INSTALLATION AND FOLLOW THEM CAREFULLY THROUGHOUT YOUR PROJECT.**

## B. DESCRIPTION OF THE FIREPLACE SYSTEM

This Heat-N-Glo fireplace system consists of the following:

1. Fireplace/Integral Grate
2. Chimney Termination Cap
3. Chimney System
4. Hearth Extension

Optional components include:

1. Glass Doors
2. Outside Combustion Air System

**NOTE: Illustrations throughout these instructions reflect "typical installations" and are for design purposes only. Actual installation may vary slightly due to individual design preferences. However, minimum and maximum clearances must be maintained at all times.**

**The illustrations and diagrams used throughout these installation instructions are not drawn to scale.**

### Tools and Building Supplies Normally Required

#### Tools:

Saw  
Pliers  
Hammer  
Phillips Screwdriver  
Tape Measure  
Plumb Line  
Level  
Electric Drill and Bits  
Framing Square

#### Building Supplies:

Hearth Extension Material  
Wall-finishing Materials  
Framing Material  
Fireplace Surround  
Caulking Material

## C. FIREPLACE SYSTEM COMPONENTS

The table below, together with the following pictures, show only those components which may be safely used with this fireplace.

HTI Cat.#	Description
RHW-44*	Fireplace, includes outside air kit, integral grate and hearth protection strips
HX3	Hearth Extension
DM1136	Original Bi-fold Glass Doors - Black Finish
DM1136A	Original Bi-fold Glass Doors - Polished Brass Finish
DM1136B	Original Bi-fold Glass Doors - Bright Brass Finish
C1136A	Classic Bi-fold Glass Doors - Brushed Brass Finish
C1136B	Classic Bi-fold Glass Doors - Polished Brass Finish
C1136C	Classic Bi-fold Glass Doors - Chrome Finish
C2136A	Classic Cabinet Glass Doors - Brushed Brass Finish
C2136B	Classic Cabinet Glass Doors - Polished Brass Finish
C2136C	Classic Cabinet Glass Doors - Chrome Finish
P1136B	Premium Series Bi-fold Glass Doors - Polished Brass Finish
GR8	Integral Grate (included with Fireplace)
ID4	Insulated Duct/Outside Air
UD4	Uninsulated Duct/Outside Air
CAK4	Chimney Air Kit
SL306	Chimney Section - 6" long
SL312	Chimney Section - 12" long
SL318	Chimney Section - 18" long
SL324	Chimney Section - 24" long
SL336	Chimney Section - 36" long
SL348	Chimney Section - 48" long
SL3	Chimney Stabilizer
SL315	Chimney Offset/Return - 15°
SL330	Chimney Offset/Return - 30°
FS338	Firestop - Straight
FS339	Firestop - 15°
FS340	Firestop - 30°
AS8	SL300 Straight Attic Insulation Shield - 24"
JB877	Chimney Joint Band
CB876	Chimney Bracket
RF370	Roof Flashing - Flat to 6/12 Pitch
RF371	Roof Flashing - 6/12 to 12/12 Pitch
ST375	Chimney Terminal Cap - Square
CT35	Chase Top
TR342	Round Telescoping Terminal Cap
TR344	Round Telescoping Terminal Cap
TS345	Square Terminal Cap
TS345P	Square Terminal Cap - Painted

\*Heat-N-Glo Catalog Number

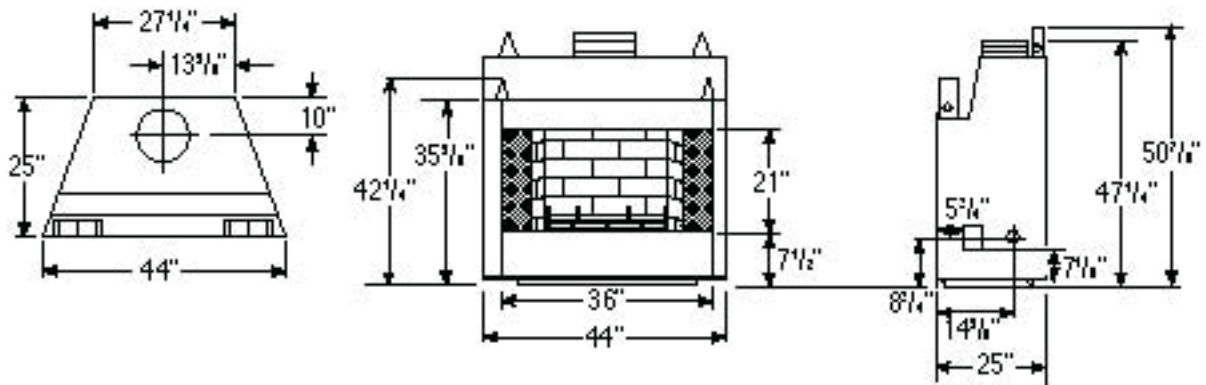

**HEARTH EXTENSION**

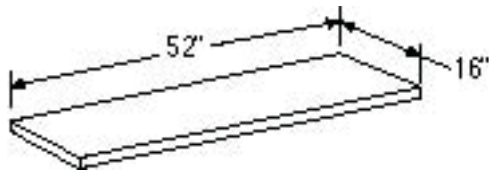

HX3

**GLASS DOORS**

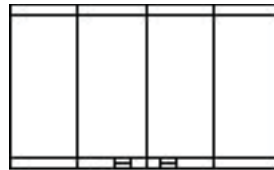

**STRAIGHT ATTIC INSULATION SHIELD**

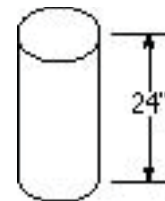

AS8

**INTEGRAL GRATE**

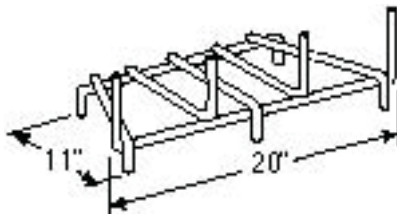

GR8

**INSULATED DUCT**

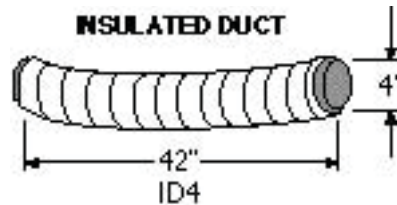

**UNINSULATED DUCT**

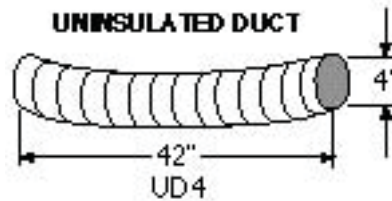

**OUTSIDE AIR KIT (SUPPLIED)**

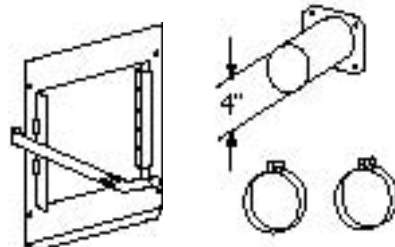

AK14

**CHIMNEY SECTIONS**

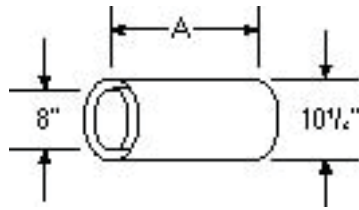

HTI CAT.#	A	B
SL306	6"	4 <sup>3</sup> / <sub>4</sub> "
SL312	12"	10 <sup>3</sup> / <sub>4</sub> "
SL318	18"	16 <sup>3</sup> / <sub>4</sub> "
SL324	24"	22 <sup>3</sup> / <sub>4</sub> "
SL336	36"	34 <sup>3</sup> / <sub>4</sub> "
SL348	48"	46 <sup>3</sup> / <sub>4</sub> "

A=Actual length  
B=Effective length (length of chimney part after it has been snapped to another)

**CHIMNEY STABILIZER**

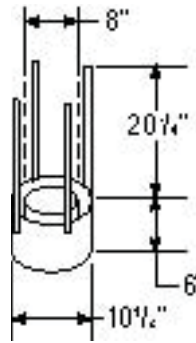

SL3

**OFFSETS/RETURNS**

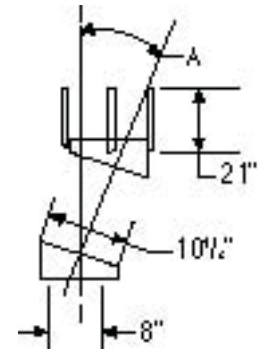

HTI CAT.#	A
SL315	15°
SL330	30°

**FIRESTOP SPACERS**

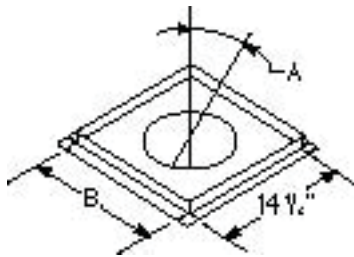

CAT. #	A	B
FS338	0°	14 <sup>1</sup> / <sub>2</sub> "
FS339	15°	18 <sup>3</sup> / <sub>8</sub> "
FS340	30°	23"

**ROOF FLASHING**

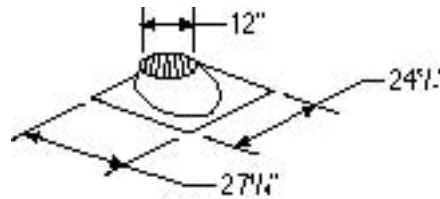

RF370  
Flat to 6/12 Pitch

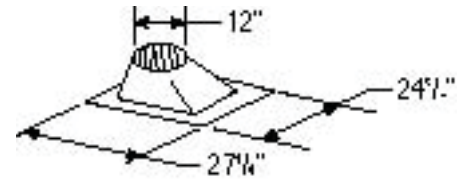

RF371  
6/12 to 12/12 Pitch

**CHIMNEY BRACKET**

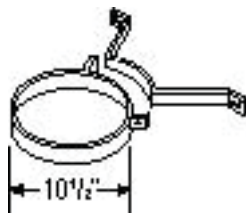

CB876

**JOINT BAND**

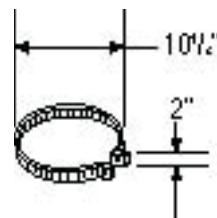

JB877

**CHIMNEY AIR KIT**

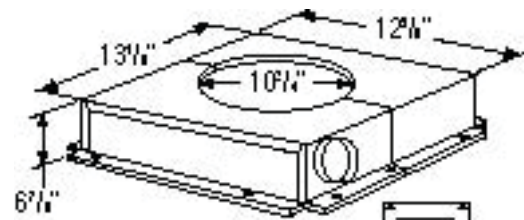

CAK4

**CHIMNEY TERMINAL CAPS & VENT SECTIONS**

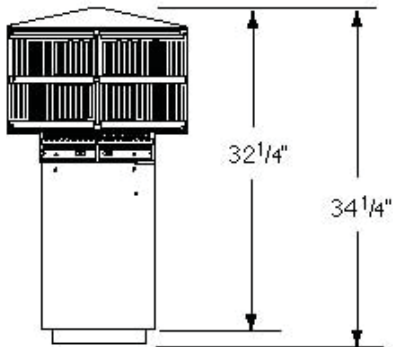

**TR342**  
**ROUND TELESCOPING**  
**TERMINAL CAP**

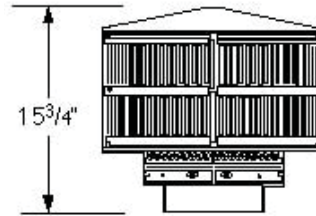

**TR344**  
**ROUND TERMINAL CAP**  
**WITH STORM COLLAR**

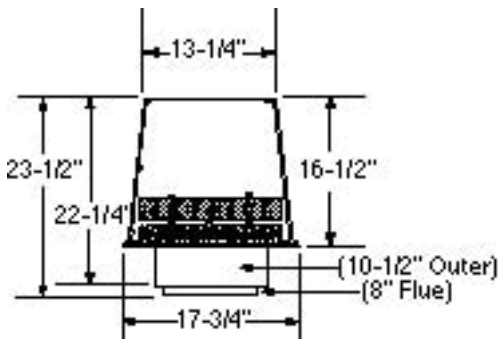

**TS345/345P**  
**SQUARE TERMINAL CAP**

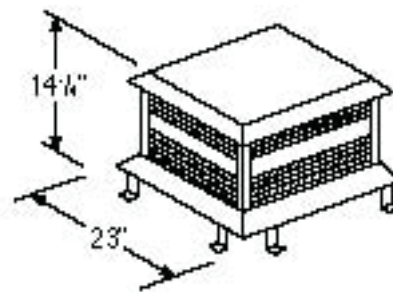

**ST375**  
**SQUARE TERMINAL CAP**

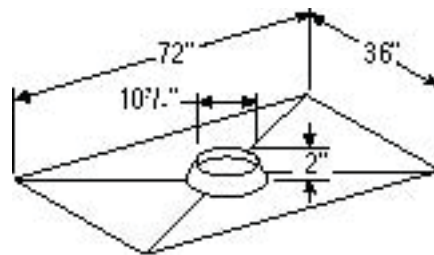

**CT35**  
**CHASE TOP**



## D. PRE-INSTALLATION PREPARATION

### 1. FIREPLACE LOCATIONS AND SPACE REQUIREMENTS

Several options are available to you when choosing a location for your fireplace. This fireplace may be used as a room divider, installed along a wall, across a corner or used in an exterior chase. See Figure 1.

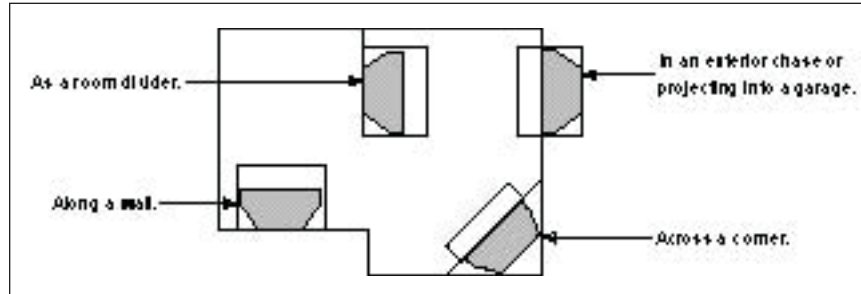
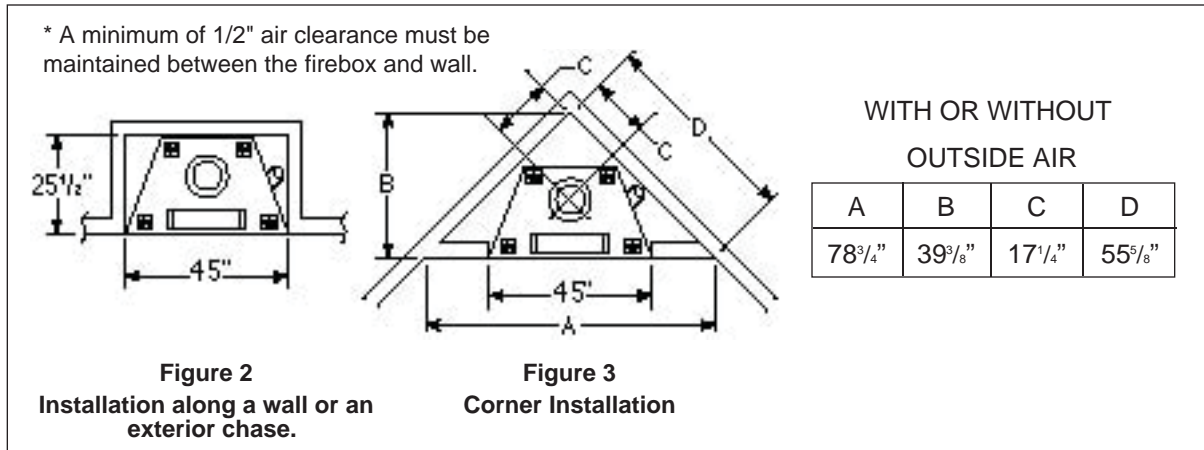

Figure 1  
Fireplace Locations

Figures 2 and 3 show two typical installations assuming an outside air kit is being used. Therefore, an allowance must be made for 90° bends. Less space is required when ducting goes directly outside without forming elbows.



### WARNING!

**DO NOT DRAW OUTSIDE AIR FROM GARAGE SPACES. EXHAUST PRODUCTS OF GASOLINE ENGINES ARE HAZARDOUS.**

**DO NOT INSTALL OUTSIDE AIR DUCTS SUCH THAT THE AIR MAY BE DRAWN FROM ATTIC SPACES, BASEMENTS OR ABOVE THE ROOFING WHERE OTHER HEATING APPLIANCES OR FANS AND CHIMNEYS EXHAUST OR UTILIZE AIR. THESE PRECAUTIONS WILL REDUCE THE POSSIBILITY FOR SMOKING OR FLOW REVERSAL.**

### WARNING!

**TO PREVENT CONTACT WITH SAGGING OR LOOSE INSULATION, THE FIREPLACE MUST NOT BE INSTALLED AGAINST VAPOR BARRIERS OR EXPOSED INSULATION. LOCALIZED OVERHEATING COULD OCCUR AND A FIRE COULD RESULT.**



**2. FRAMING THE FIREPLACE**



The RHW-44 fireplace will fit a framed opening of 45" wide x 42" tall. The finished cavity depth must be no less than 25½" .

Figure 4 shows a typical framing (using 2 x 4 lumber) of the fireplace, assuming combustible materials are used. All required clearances to combustibles around

the fireplace must be adhered to. Any framing across the top of the fireplace must be above the level of the top standoffs. An ½ " air clearance must be maintained at the back and sides of the firebox assembly. Chimney Sections at any level require a 2" minimum air space clearance between the framing and chimney section.

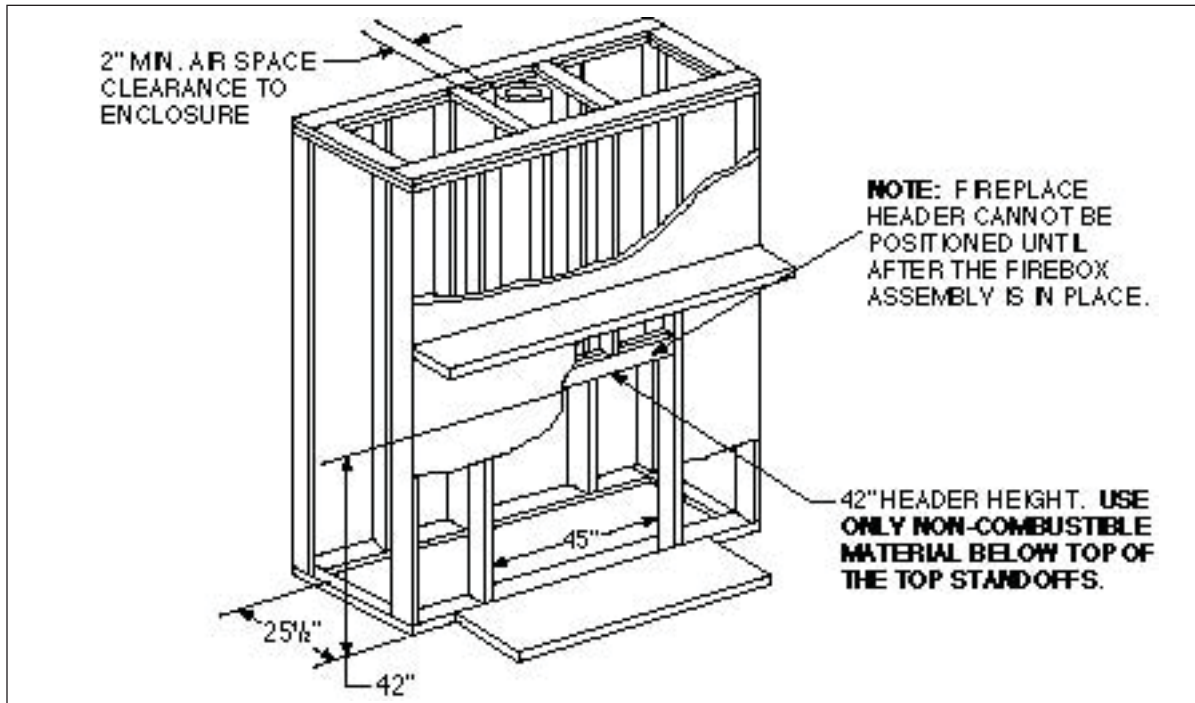

**Figure 4**  
**Framing the Fireplace**

**Combustible Material.** Material made of or surfaced with wood, compressed paper, plant fibers, plastics, or any material capable of igniting and burning, whether flame proofed or not, plastered or unplastered.

**Non-combustible Material.** Material which will not ignite and burn. Such materials are those consisting entirely of steel, iron, brick, tile, concrete, slate, glass or plasters, or combination thereof.

**Non-combustible Sealant Material.** Sealants that will not ignite and burn; General Electric RTV103

(Black), or equivalent. Rutland, Inc. Fireplace Mortar #63, or equivalent.

After completing the framing and applying the facing material (dry wall) over the framing, a non-combustible sealant, one-half inch wide maximum, must be used to close off any gaps at the top and sides between the fireplace and facing to prevent cold air leaks

Only non-combustible materials may be used to cover the black metal fireplace front.

**WARNING!**

**DO NOT APPLY COMBUSTIBLE FINISHING MATERIALS OVER ANY PART OF THE BLACK FACE OF THIS FIREPLACE OR A STRUCTURE FIRE MAY RESULT. THE BLACK METAL FACE MAY ONLY BE COVERED WITH NON-COMBUSTIBLE MATERIALS.**

**2. HEARTH EXTENSIONS**

A hearth extension must be installed with all fireplaces. It is to protect the combustible floor in front of the fireplace from both radiant heat and sparks.

The construction of and materials used for a field constructed hearth extension are shown in Figure 5.

A hearth extension of this construction may be covered with any non-combustible decorative material and may have a maximum thickness of 7½". Seal gaps between the hearth extension and the front of the fireplace with a non-combustible sealant.

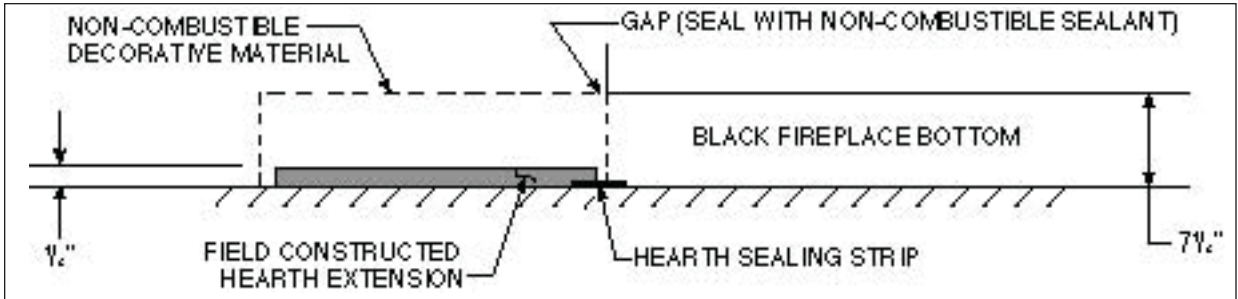

**Figure 5**  
**Field Constructed Hearth Extension**

Field constructed Hearth Extensions should be constructed in accordance with Figures 5 and 6 instructions. In all cases, the hearth extension must extend a minimum of 16" to the front and 8" on either side of the fireplace opening. The field constructed hearth extension must be constructed from 1/2" MICORE CV230.

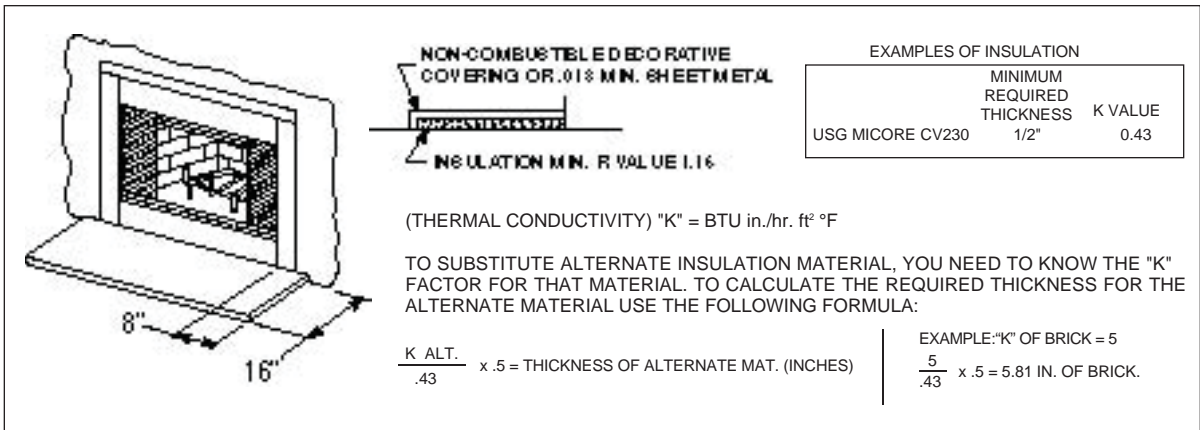

**Figure 6**  
**Hearth Extension**

**WARNING!**

**HEARTH EXTENSIONS ARE TO BE INSTALLED ONLY AS ILLUSTRATED TO PREVENT HIGH TEMPERATURES FROM OCCURRING ON CONCEALED COMBUSTIBLE MATERIALS. HEARTH SEALING STRIPS PREVENT BURNING OR HOT PARTICLES FROM INADVERTENTLY FALLING DIRECTLY ON COMBUSTIBLE SURFACES IN THE EVENT THE BUILDING SHOULD SETTLE AND DISTURB THE ORIGINAL CONSTRUCTION.**

**4. SIDEWALLS/SURROUNDS**

Adjacent combustible side walls must be located a minimum of 20" from the fireplace opening. See Figure 7. If you are using a decorative surround constructed of combustible material, it must be located within the shaded area defined in Figure 7. Short stub walls are also acceptable if they are contained within the shaded area.

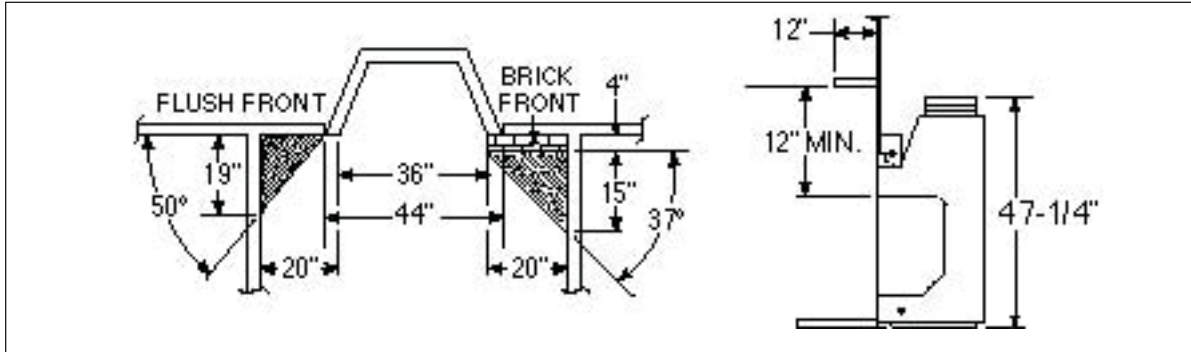

**Figure 7**  
**Sidewalls/Surrounds**

**5. MANTEL**

A combustible mantel may be positioned no lower than 12" above the top of the firebox opening. The combustible mantel may have a maximum depth of 12". Combustible trim materials, projecting no more than 1-1/2" from the face of the fireplace, can be placed no closer than 6" from the top and side of the firebox opening. See the shaded areas on each side of the firebox, as defined in Figure 7. Combustible trim must not cover the black metal surfaces of the fireplace. This mantel clearance is in accordance with Section 7-3.3.3 of ANSI/NFPA 211.

**E. CHIMNEY REQUIREMENTS**

When planning your fireplace location, the chimney construction and necessary clearances must be considered. The fireplace system and chimney components have been tested to provide the following flexibility in construction. The following figures are the minimum distances from the base of the unit.

Minimum overall straight height	14.5 ft.
Minimum height with Offset/Return	16 ft.
Maximum height	90 ft.
Maximum chimney length between an Offset/Return	10 ft.
Maximum distance between Chimney Stabilizers	35 ft.
Double Offset/Return minimum height	20 ft.
Maximum unsupported chimney length between Offset/Return	6 ft.
Maximum straight unsupported chimney height above firebox	35 ft.

**1. USING OFFSETS AND RETURNS.**

To bypass any overhead obstructions, the chimney may be offset using a 15° offset/return (SL315) or a 30° offset/return (SL330). Perform the following steps to determine the correct chimney component combination for your particular installation.

An offset and return may be attached together or a chimney section(s) may be used between an offset and return. However, the distance between two elbows must never exceed 10 feet in total length.

- a. Measure how far the chimney needs to be shifted to enable it to avoid the overhead obstacle. See Figure 8, dimension "A".

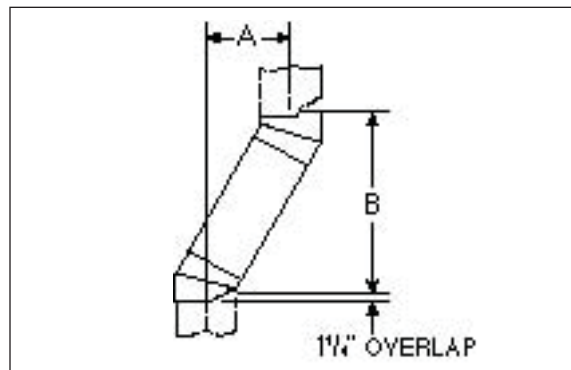

**Figure 8**  
**Chimney Offset/Return**

- b. After determining the offset dimension, refer to Table 1 and find the "A" dimension closest to **but not less than** the distance of shift needed for your installation.
- c. The "B" dimension that coincides with the "A" dimension represents the required vertical clearance that is needed to complete the offset and return.
- d. Read across the chart and find the number of chimney sections required and the model number of those particular chimney parts.
- e. Whenever the chimney penetrates a floor/ceiling, a firestop spacer must be installed.

**Example:** Your "A" dimension from Figure 8 is 14½". Using Table 1, the dimension closest to but not less than 14½" is 14¾" using a 30° offset/return. It is then determined from the table that you would need 33" (Dimension "B") between the offset and return. The chimney components that best fit your application are two [2] SL312's.

**WARNING!**

**DO NOT COMBINE OFFSETS TO CREATE AN OFFSET GREATER THAN 30° FROM VERTICAL. THIS MAY CREATE A FIRE HAZARD SINCE THE NATURAL DRAFT MAY BE RESTRICTED.**

**Offset Chart\*** **TABLE 1**

15°		30°		SL306	SL312	SL318	SL324	SL336	SL348
A	B	A	B						
15 <sup>5</sup> / <sub>8</sub> "	13 <sup>3</sup> / <sub>8</sub> "	37 <sup>7</sup> / <sub>8</sub> "	14 <sup>1</sup> / <sub>2</sub> "	—	—	—	—	—	—
27 <sup>7</sup> / <sub>8</sub> "	17 <sup>3</sup> / <sub>4</sub> "	6 <sup>1</sup> / <sub>4</sub> "	18 <sup>5</sup> / <sub>8</sub> "	1"	—	—	—	—	—
—	—	8 <sup>5</sup> / <sub>8</sub> "	22 <sup>3</sup> / <sub>4</sub> "	2"	—	—	—	—	—
4 <sup>1</sup> / <sub>2</sub> "	23 <sup>5</sup> / <sub>8</sub> "	9 <sup>1</sup> / <sub>4</sub> "	23 <sup>3</sup> / <sub>4</sub> "	—	1"	—	—	—	—
—	—	11 <sup>5</sup> / <sub>8</sub> "	27 <sup>7</sup> / <sub>8</sub> "	1"	1"	—	—	—	—
6"	29 <sup>3</sup> / <sub>8</sub> "	12 <sup>1</sup> / <sub>4</sub> "	29"	—	—	1"	—	—	—
7 <sup>1</sup> / <sub>4</sub> "	34"	14 <sup>5</sup> / <sub>8</sub> "	33"	—	2"	—	—	—	—
—	—	15 <sup>1</sup> / <sub>4</sub> "	34 <sup>1</sup> / <sub>8</sub> "	—	—	—	1"	—	—
—	—	17 <sup>5</sup> / <sub>8</sub> "	38 <sup>1</sup> / <sub>4</sub> "	1"	—	—	1"	—	—
—	—	20 <sup>5</sup> / <sub>8</sub> "	43 <sup>1</sup> / <sub>2</sub> "	—	—	2"	—	—	—
10 <sup>5</sup> / <sub>8</sub> "	46 <sup>3</sup> / <sub>4</sub> "	21 <sup>1</sup> / <sub>4</sub> "	44 <sup>5</sup> / <sub>8</sub> "	—	—	—	—	1"	—
11 <sup>7</sup> / <sub>8</sub> "	51 <sup>3</sup> / <sub>8</sub> "	23 <sup>5</sup> / <sub>8</sub> "	48 <sup>3</sup> / <sub>4</sub> "	1"	—	—	—	1"	—
—	—	26 <sup>5</sup> / <sub>8</sub> "	53 <sup>7</sup> / <sub>8</sub> "	—	—	—	2"	—	—
13 <sup>3</sup> / <sub>4</sub> "	58 <sup>3</sup> / <sub>8</sub> "	27 <sup>1</sup> / <sub>4</sub> "	55 <sup>3</sup> / <sub>4</sub> "	—	—	—	—	—	1"
15"	63"	29 <sup>5</sup> / <sub>8</sub> "	59"	1"	—	—	—	—	1"
16 <sup>1</sup> / <sub>2</sub> "	68 <sup>3</sup> / <sub>4</sub> "	32 <sup>5</sup> / <sub>8</sub> "	64 <sup>1</sup> / <sub>4</sub> "	—	1"	—	—	—	1"
18"	74 <sup>5</sup> / <sub>8</sub> "	35 <sup>5</sup> / <sub>8</sub> "	69 <sup>1</sup> / <sub>2</sub> "	—	—	1"	—	—	1"
—	—	38 <sup>5</sup> / <sub>8</sub> "	74 <sup>5</sup> / <sub>8</sub> "	—	—	—	1"	—	1"
—	—	41"	78 <sup>3</sup> / <sub>4</sub> "	1"	—	—	1"	—	1"
22 <sup>3</sup> / <sub>4</sub> "	91 <sup>7</sup> / <sub>8</sub> "	44 <sup>5</sup> / <sub>8</sub> "	85"	—	—	—	—	1"	1"
24"	96 <sup>1</sup> / <sub>2</sub> "	47"	89 <sup>1</sup> / <sub>8</sub> "	1"	—	—	—	1"	1"
25 <sup>7</sup> / <sub>8</sub> "	103 <sup>1</sup> / <sub>2</sub> "	50 <sup>5</sup> / <sub>8</sub> "	95 <sup>1</sup> / <sub>2</sub> "	—	—	—	—	—	2"

\*Proper assembly of air cooled chimney parts result in an overlap at chimney joints of 1¼". Effective length is built into this chart.

**2. CHIMNEY HEIGHT REQUIREMENTS  
(Above the roof line)**

Major building codes specify a minimum chimney height above the roof top. These specifications are summarized in what is known as the “Ten Foot Rule”. This rule states:

If the horizontal distance from the side of the chimney to the peak of the roof is 10 feet or less, the top of the chimney must be at least 2 feet above the peak of the roof, but never less than 3 feet in overall height above the highest point where it passes through the roof. See Figure 9.

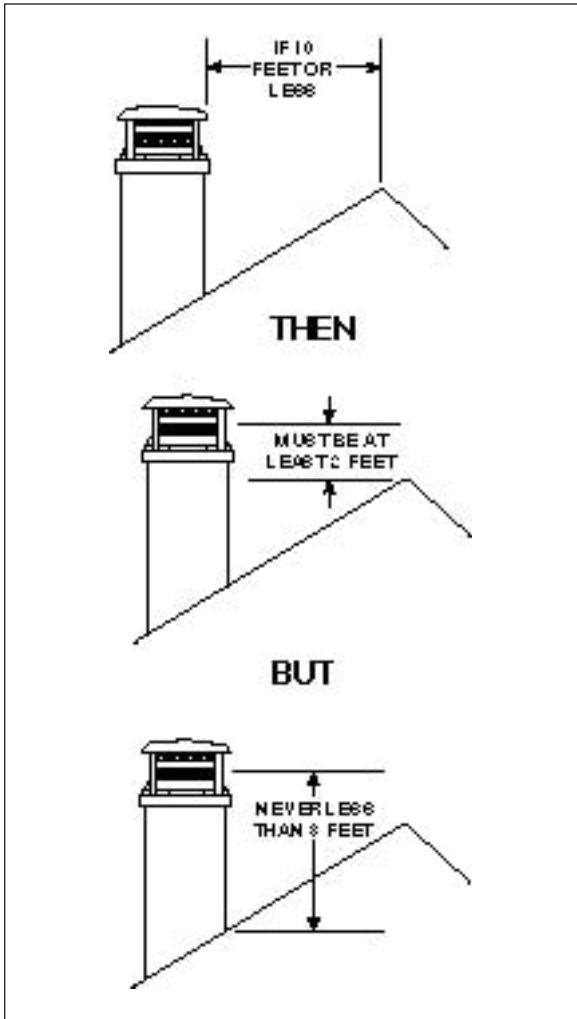

**Figure 9  
Chimney Height**

If the horizontal distance from the side of the chimney to the peak of the roof is more than 10 feet, a chimney height reference point is established on the surface of the roof a distance of 10 feet from the side of the chimney in a horizontal plane. The top of the

chimney must be at least 2 feet above this reference point, but never less than 3 feet in height above the highest point where it passes through the roof.

These chimney heights are necessary in the interest of safety and do not ensure smoke-free operation. Trees, buildings, steeply pitched roofs, adjoining roof lines, adverse wind conditions, etc., may create a need for a taller chimney should smoking occur.

**3. DETERMINING THE NUMBER OF CHIMNEY SECTIONS REQUIRED**

To determine the chimney components needed to complete your particular installation, follow the below steps:

- a. Determine the total vertical height of the fireplace installation. This dimension is measured from the base of the firebox assembly to the point where the smoke exits the terminal cap.
- b. Subtract the height of the firebox assembly (47-1/4") from the overall height of the fireplace installation.
- c. Reference the chart below to determine what components must be selected to complete the fireplace installation.
- d. Determine the number of firestop spacers, stabilizers, roof flashing, etc. required to complete the fireplace installation.

Height of Chimney Components	
<b>Chimney Stabilizer</b>	
SL3	4¾"
<b>Firestop Spacers</b>	
FS338	0
FS339	0
FS340	0
<b>Offset/Returns</b>	
SL315	13¾"
SL330	14½"
<b>Roof Flashing</b>	
RF370	0
RF371	0
<b>Chimney Sections*</b>	
SL306	4¾"
SL312	10¾"
SL318	16¾"
SL324	22¾"
SL336	34¾"
SL348	46¾"

\*Dimensions reflect effective height.

## F. STEP-BY-STEP INSTALLATION OF THE FIREPLACE SYSTEM

### WARNING!

**BEFORE STARTING, DO THE FOLLOWING:**

- 1. WEAR GLOVES AND SAFETY GLASSES FOR PROTECTION.**
- 2. KEEP HAND TOOLS IN GOOD CONDITION. SHARPEN CUTTING EDGES AND MAKE SURE TOOL HANDLES ARE SECURE.**
- 3. ALWAYS MAINTAIN THE MINIMUM AIR SPACE REQUIRED TO THE ENCLOSURE TO PREVENT FIRE.**

#### STEP 1 - Positioning the Fireplace.

This fireplace may be placed on either a combustible or non-combustible continuous surface. Follow the instructions for framing on page 9. Be sure to provide the minimum 1/2" air clearance at the sides and back of the firebox assembly.

**NOTE: The firebox assembly must be in position prior to nailing the fireplace headers in place.**

#### STEP 2 - Placing the Protective Metal Hearth Strips.

Included with your fireplace you will find two metal hearth strips measuring approximately 28" x 4". These strips are used to provide added protection where the fireplace and hearth extension meet.

Slide the metal strips two inches under the front edge of the fireplace. The individual pieces must overlap each other by one inch in the middle of the fireplace to provide continuous coverage of the floor. See Figure 10. These metal strips should extend from the front and sides of the fireplace by 2".

#### STEP 3 - Leveling the Fireplace.

Level the fireplace side-to-side and front-to-back. Shim with non-combustible material, such as sheet metal, as necessary.

**Important: To ensure proper fit of the glass doors, check the firebox opening for squareness. Measure diagonal distances of the opening to make sure they are equal. If they do not equal, continue to shim the firebox until those diagonals correspond.**

Secure the fireplace by utilizing the nailing flanges located on either side of the fireplace to the vertical framing.

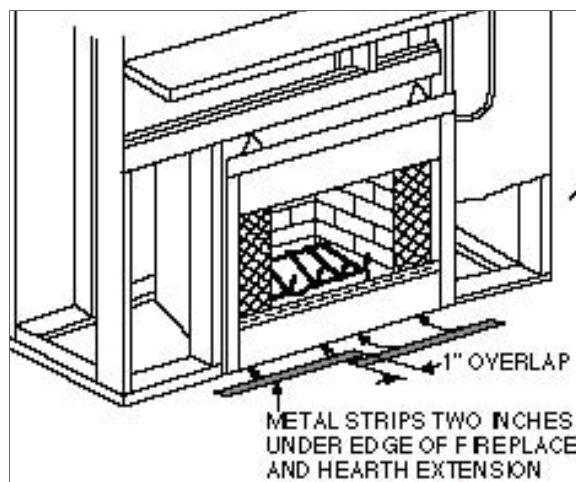

Figure 10  
Positioning the Metal Strips

### WARNING!

**CAREFULLY FOLLOW THE INSTRUCTIONS FOR ASSEMBLY OF THE PIPE AND OTHER PARTS NEEDED TO INSTALL THIS FIREPLACE SYSTEM. FAILURE TO DO SO MAY RESULT IN A FIRE, ESPECIALLY IF COMBUSTIBLES ARE TOO CLOSE TO THE FIREPLACE OR CHIMNEY AND AIR SPACES ARE BLOCKED PREVENTING THE FREE MOVEMENT OF COOLING AIR.**



**STEP 4 - Assembling Chimney Sections.**

Attach either a straight chimney section or an offset to the top of the fireplace depending on your installation requirement. Chimney sections are locked together by pushing downward until the top section meets the stop bead on the lower section. When using offsets/returns, it is highly recommended that the offset and return sections be secured in place with screws to ensure proper orientation. See Figure 11.

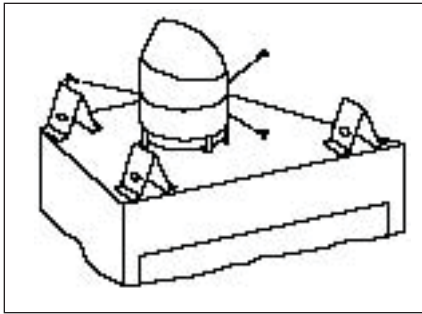

**Figure 11**  
Connecting Chimney Sections

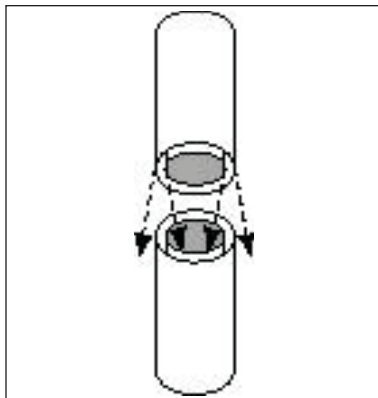

**Figure 12**  
Connecting Chimney Sections

**NOTE:** The inner flue is placed to the inside of the flue section below it. The outer casing is placed outside the outer casing of the chimney section below it. See Figure 12.

to the ceiling joists from the bottom or fireplace side, **EXCEPT** when the space above is an insulated ceiling or attic space. In this situation, the firestop spacer must be nailed from the top side to prevent loose insulation from falling into the required two inch air space around the chimney. See Figure 13.

Firestop spacers must be used whenever the chimney penetrates a ceiling/floor area.

**CAUTION:**

**INNER FLUE AND OUTER LINER SECTIONS CANNOT BE DISASSEMBLED ONCE LOCKED TOGETHER. PLAN AHEAD TO INSURE THE PROPER INSTALLATION HEIGHT IS ACHIEVED WITH THE SELECTED CHIMNEY COMPONENTS.**

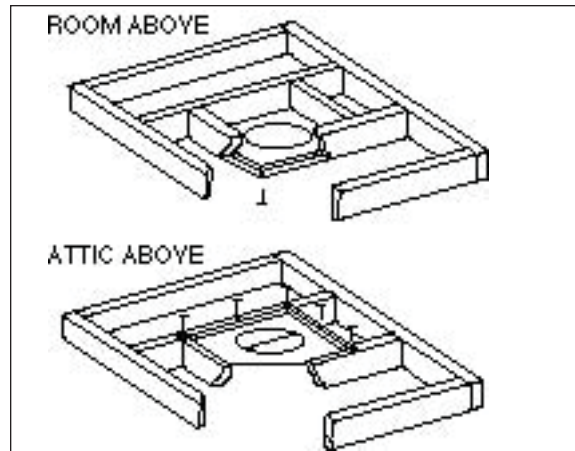

**Figure 13**  
Installing the Firestop Spacer

**STEP 5 - Preparing the Ceiling for Firestop Spacers.**

Mark and cut out an opening in the ceiling for the particular firestop spacer being utilized (14-1/2" x 14-1/2" for an FS338, or 14-1/4" x 18-3/4" for an FS339, or 14-1/2" x 23" for an FS340). Frame the opening with the same dimension lumber used in the ceiling joists.

**STEP 6 - Installing the Firestop Spacers.**

Install the firestop spacer FS338 (Straight), FS339 (if a 15° offset is located in the ceiling joist area), or FS340 (if a 30° offset is located in the ceiling joist area). Nail the four sides of the firestop spacer to the joists using a minimum of three [3] nails per side.

These firestop spacers are designed to provide the minimum 2" air space required around the chimney. In all situations, the firestop spacers are to be nailed

**STEP 7 - Installing an AS8 Insulation Shield.**

An AS8 insulation shield should be installed when there is a possibility of insulation coming into contact with the factory-built chimney system. The AS8 is installed by positioning it over the vertical chimney section where it penetrates an FS338 firestop spacer. The FS338 will support the AS8. See Figure 14. When the factory-built chimney penetrates an insulated ceiling at either 15 or 30 degrees from vertical, an insulation dam should be constructed from plywood or sheet metal. A minimum 2" air space must be provided between the insulation dam and the factory-built chimney system.



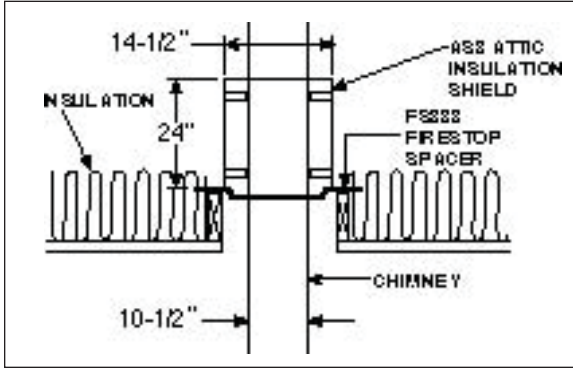

Figure 14 - Installing an AS8

**STEP 8 - Double-checking Chimney Assembly.**

Continue assembling the chimney sections up through the firestop spacers as needed. While doing so, be aware of the height and unsupported chimney length limitations that are given on page 11 under “Chimney Requirements”.

Check each section by pulling up slightly from the top to ensure proper engagement before installing the succeeding sections. If they have been connected correctly, they will not disengage when tested.

**STEP 9 - Securing Chimney System.**

When offsets and returns are joined to straight pipe sections, they must be locked into position with the screws provided, using the predrilled holes. To prevent gravity from pulling the chimney sections apart, the returns and the chimney stabilizers have straps for securing these parts to joists or rafters. See Figure 15.

**NOTE:** Be sure to provide support for the pipe during construction and check to be sure inadvertent loading has not dislodged the chimney section from the fireplace or at any chimney joint.

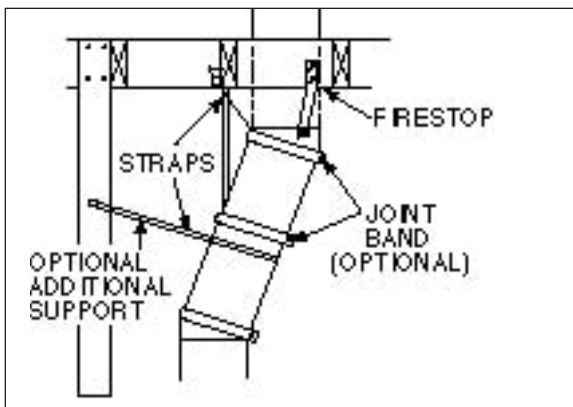

Figure 15  
Offset/Return with Stabilizer

**WARNING!**  
**WHEN CHIMNEY SECTIONS EXCEEDING SIX FEET IN LENGTH ARE INSTALLED BETWEEN AN OFFSET/ RETURN, STRUCTURAL SUPPORT MUST BE PROVIDED TO REDUCE OFF-CENTER LOADING AND PREVENT CHIMNEY SECTIONS FROM SEPARATING AT THE CHIMNEY JOINTS.**

**STEP 10 - Marking the Exit Point of the Roof.**

Locate the point where the chimney will exit the roof by plumbing down to the center of the chimney. Drive a nail up through the roof to mark the center. See Figure 16.

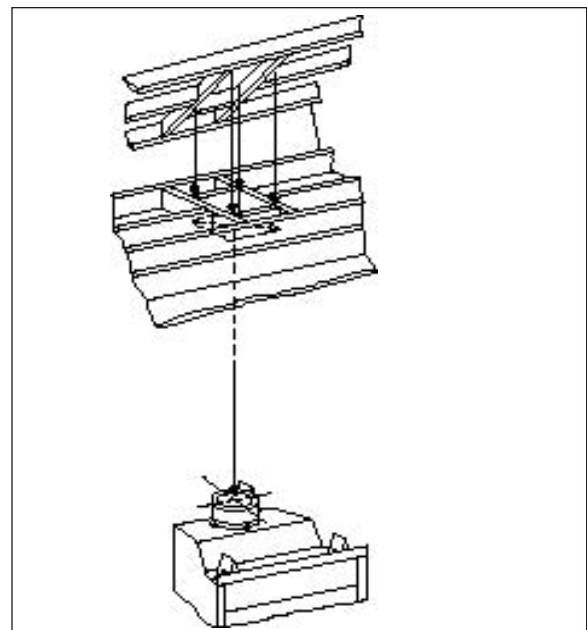

Figure 16 - Ceiling and Attic Construction

**STEP 11 - Cutting out the Hole in the Roof.**

Measure to either side of the nail and mark the 14-1/2" x 14-1/2" opening required. This is measured on the horizontal; actual length may be larger depending on the pitch of the roof. Cut out and frame the opening. See chapter 25 of the Uniform Building Code for Roof Framing details. Be sure to maintain a 2" minimum air space between the chimney section and the roof.

**STEP 12 - Assembling Chimney Sections.**

Continue to add chimney sections through the roof opening, maintaining at least a 2" air space.

**STEP 13 - Installing the Roof Flashing (optional).**

If a roof flashing is to be used, install the roof flashing appropriate to the roof pitch and install a TR344 terminal cap following the instructions shipped with the accessory.

**STEP 14 - Installing the CAK4.**

When installing a CAK4 chimney air kit, follow the instructions provided with this accessory. Use of a CAK4 is required in Canada.

**STEP 15 - Installing an Outside Air Kit (standard).**

The outside air kit is supplied as a standard feature with this fireplace and its use is highly recommended to minimize the effects of negative pressure within the structure. Figure 17 illustrates two of many possible methods that can be used to supply outside air to the fireplace system.

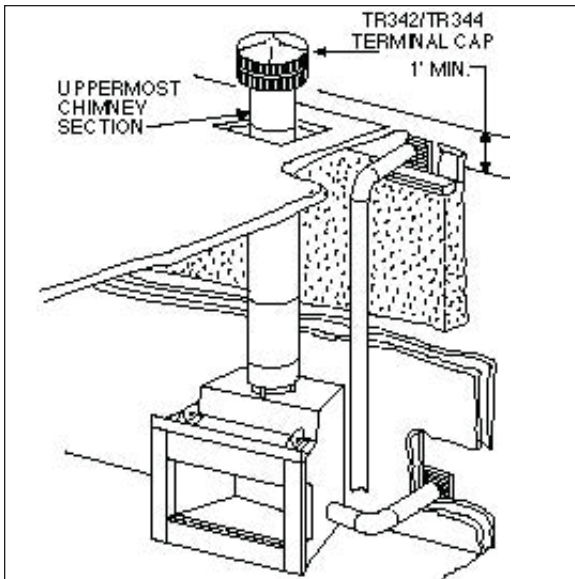

Figure 17  
Outside Air Location

**NOTE:** The outside air kit can terminate at any level with the exception that it must terminate at least one foot below the chimney terminal cap as shown in Figure 17.

The outside air kit may be installed on either the left hand or right hand side of the fireplace. Remove the cover plate from the side of the firebox assembly where the air kit is to be installed. See Figures 18 and 19.

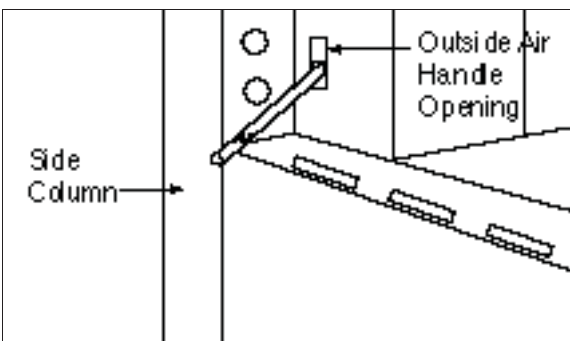

Figure 18 - Air Kit Installation

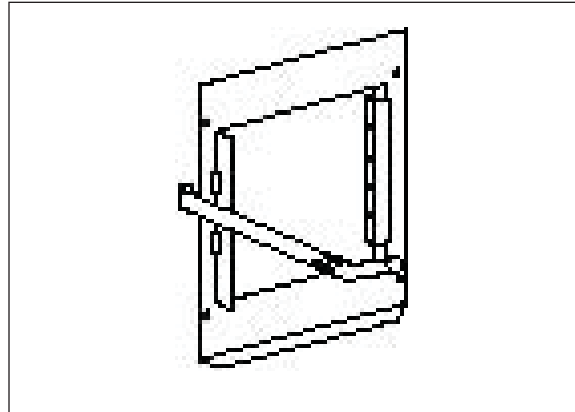

Figure 19  
Air Kit Handle Assembly

**STEP 16 - Completion of Fireplace Enclosure.**

Complete the fireplace enclosure, allowing space for outside air ducts and gas piping if desired. Electrical wiring should not come in contact with the unit. A minimum clearance of an 1/2" must be maintained between the fireplace sides and the enclosure as well as the fireplace back and the enclosure. See Figure 4 for framing details.

**NOTE:** Use only a non-combustible material to finish the face of the fireplace below the level of the front standoffs. A non-combustible material such as USG MICORE CV230 Mineral Fiber Board, or USG DUROCK Cement Board is recommended for this purpose.



**STEP 17 - Provisions for a Gas Log Set or Gas Log Lighter.**

Knockouts are provided on both sides of the fireplace for the connection of a certified gas log lighter or a decorative gas appliance with a maximum input of 100,000 BTU/hr incorporating an automatic gas shutoff device and complying with the Standard for Decorative Gas Appliances for Installation in Vented Fireplaces, ANSI Z21.60. The decorative gas appliance should be installed in accordance with the National Fuel Gas Code, ANSI Z223.1. The side refractories are designed to allow 1/2" iron pipe to pass through. Use a non-combustible sealant to seal any opening between the gas pipe and the refractory on the inside. Repack the insulation removed, to seal around the gas pipe where it exits the side of the fireplace. A minimum 1-1/2" air clearance must be provided to the 1/2" iron pipe. See Figure 20 for the shaded area.

**WARNING!**

**THIS FIREPLACE WAS NOT TESTED BY THE FIREPLACE MANUFACTURER FOR USE WITH AN UNVENTED GAS LOG HEATER. DO NOT INSTALL AN UNVENTED GAS LOG HEATER IN THIS FIREPLACE UNLESS IT HAS BEEN SPECIFICALLY TESTED AND LISTED BY UNDERWRITERS LABORATORIES INC FOR USE IN THIS SPECIFIC MODEL FIREPLACE. UNLESS THE UNVENTED GAS LOG HEATER IS TESTED AND LISTED FOR USE IN THIS FACTORY-BUILT FIREPLACE, A FIRE HAZARD MAY BE CREATED THAT CAN RESULT IN A STRUCTURE FIRE.**

**CAUTION:**

**WHEN USING A GAS LOG SET, THE FIREPLACE DAMPER MUST BE SET IN THE FULLY OPEN POSITION. THIS ENSURES A PROPER VENTING OF COMBUSTION PRODUCTS.**

**STEP 18 - Installing the Glass Doors.**

If desired, or required by local building codes, install the glass doors using the instructions supplied with the particular set of doors you have chosen.

**STEP 19 - Positioning the Hearth Extension.**

Position and secure the hearth extension over the protective metal strips that have been placed partially under the firebox front. These strips should be protruding approximately two inches from under the fireplace front. Seal the crack between the hearth extension and fireplace with a non-combustible sealant.

**STEP 20 - Applying Finishing Materials on the Hearth Extension.**

Apply the non-combustible finishing material of your choice to the hearth extension. **Do not install combustible materials over the black face of the fireplace. This poses a safety hazard and may start a fire.** You may only use non-combustible material over the black face of the fireplace. Refer to Figure 7 for combustible material information.

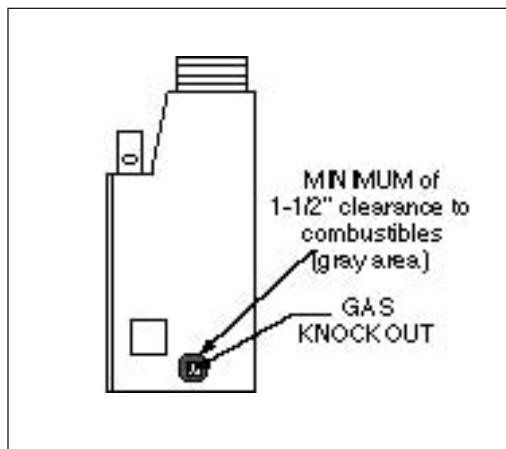

**Figure 20**  
Gas Knockout Location

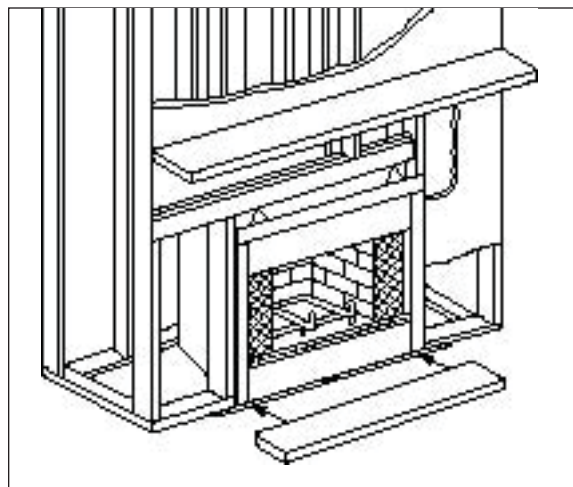

**Figure 21**  
Positioning the Hearth Extension

## G. CONSTRUCTING A CHASE

A chase is a vertical box-like enclosure built around the chimney and firebox. A chase may be constructed for the fireplace and chimney or for the chimney only. It is most commonly constructed on an outside wall.

In cold climates, it is recommended that the chase floor be insulated using batt type insulation between the floor joists.

Three examples of chase applications are shown in Figure 22.

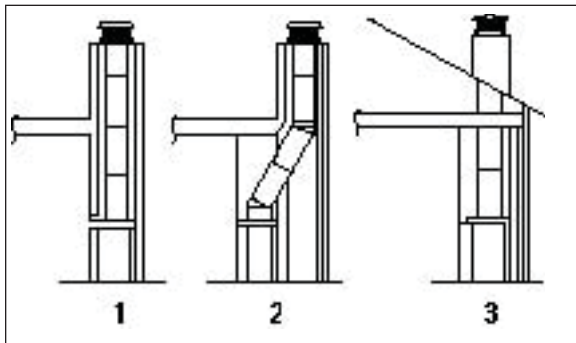

**Figure 22**  
Chase Constructions

- a. Fireplace and chimney enclosed in an exterior chase.
- b. Chimney offset through exterior wall and enclosed in chase.
- c. Chase constructed on roof.

### 1. Materials for the Chase

The chase is constructed using framing materials much the same as the walls in your home. A variety of materials may be used including brick, stone, veneer brick, or standard siding materials.

In constructing the chase, several factors must be considered.

- a. Maintain an 1/2" minimum air space around the firebox.
- b. Maintain a 2" air space around the chimney.
- c. The chase top must be constructed of a non-combustible material.

- d. In cold climates a firestop spacer should be installed in an insulated false ceiling at the 8 foot level above the firebox assembly. This prevents heat loss through the fireplace.
- e. In cold climates, the walls of the chase should be insulated to the level of the false ceiling as shown in Figure 23. This will help prevent heat loss from the home around and through the fireplace.

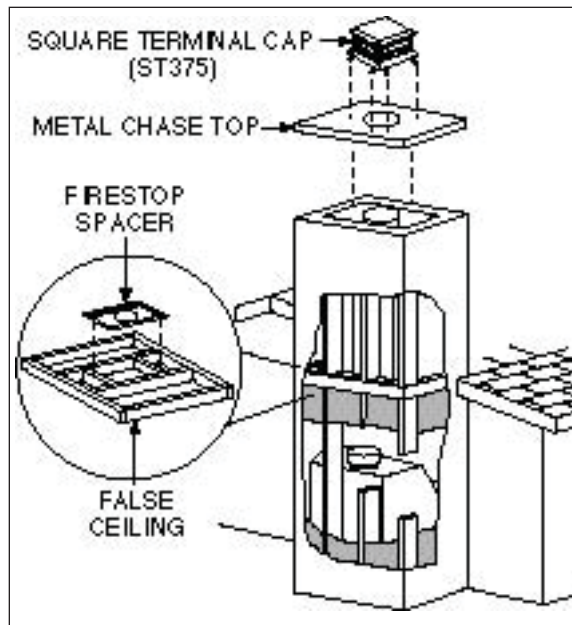

**Figure 23 - Chase Assembly**

### **WARNING!**

**DETAIL INSTRUCTIONS FOR INSTALLATION OF THE CHASE TOP, STORM COLLAR AND TERMINAL CAP ARE PACKAGED WITH THESE PARTS. TO AVOID DANGER OF FIRE, ALL INSTRUCTIONS MUST BE STRICTLY FOLLOWED, INCLUDING THE PROVISION OF AIR SPACE CLEARANCE BETWEEN CHIMNEY SYSTEM AND ENCLOSURE. TO PROTECT AGAINST EFFECTS OF CORROSION ON THOSE PARTS EXPOSED TO THE WEATHER, WE RECOMMEND THAT THE CHASE TOP AND TERMINAL CAP BE PAINTED WITH A RUST RESISTANT PAINT.**

## 2. Installing a Terminal Cap on a Chase Enclosed Chimney.

Construct a chase of desired materials maintaining a minimum 2" air space around the chimney.

### WARNING!

**NEVER INSTALL A SINGLE WALL SLIP SECTION OR SMOKE-PIPE IN A CHASE STRUCTURE. THE HIGHER TEMPERATURE OF THIS SINGLE WALL PIPE MAY RADIATE SUFFICIENT HEAT TO COMBUSTIBLE CHASE CONSTRUCTION MATERIALS TO CAUSE A FIRE.**

For installations utilizing a telescoping round terminal cap (TR342), the uppermost chimney section must be below the top of the chase top, but not more than 14-1/2" below the top of the chase top flashing collar.

For installations utilizing a square terminal cap (ST375), the last chimney section must not be more than 4-3/4" below the chase top. See Figure 24.

When installing a TS345 Square Termination, the uppermost chimney section must not be more than 3" below the chase top. See Figure 24.

Attach the chase top (CT35) to the top of the chase.

Install the terminal cap, using the instructions provided with it.

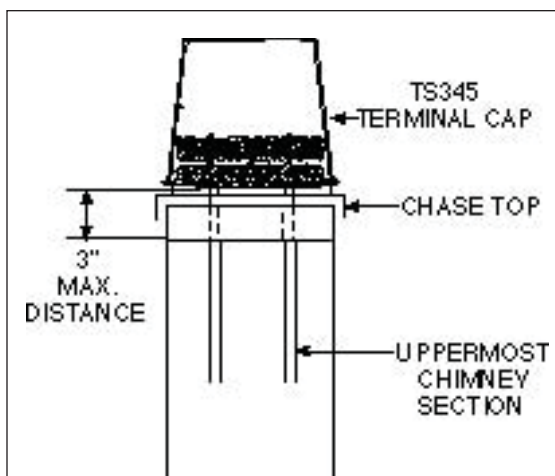

Figure 24  
Installing a Terminal Cap

## H. OPERATING INSTRUCTIONS

### NOTICE:

**SAVE AND PASS THESE OPERATING INSTRUCTIONS AND THE INSTALLATION INSTRUCTIONS TO SUBSEQUENT OWNERS. THE INFORMATION PROVIDED IS INTENDED TO NOTIFY AND WARN THEM ABOUT MAKING UNSAFE FUTURE MODIFICATIONS SUCH AS THE ADDITION OF SHELVES OR THE USE OF UNAUTHORIZED PARTS AND REPAIRS.**

**This fireplace is intended to operate as a supplemental heat source for a single room. It is not designed to function as a primary heat source for a structure.**

Fireplaces, as well as other woodburning appliances, have been used safely for many years. It has been our experience that most problems are caused by the improper installation and operation of the unit. Make certain installation and operation of the fireplace system is in accordance with these instructions.

It is extremely important that the fire be supervised whenever the fireplace is in use. It is also recommended that an annual inspection be performed on the fireplace system to determine if the flue system needs to be cleaned, or as in the case of any appliance, if minor repairs are required to maintain the system in top operating condition.

**INTENDED USAGE.** This factory-built fireplace is intended for use with either solid fuel (firewood) or a decorative gas appliance that has been tested and listed to the Standard for Decorative Gas Appliances for Installation in Vented Fireplaces, ANSI Z21.60. **When operating your fireplace, the flue damper must be in the open position.**

This fireplace was not tested and listed for use with an unvented gas log heater. Do not install an unvented gas log heater in this fireplace and operate it with the flue damper in the closed position unless the unvented gas log set has been specifically tested and listed for use in this fireplace by Underwriters Laboratories Inc. Use of an unvented gas log heater in this factory-built fireplace may create a fire hazard that can result in a structure fire.



**WARNING!**

**DO NOT OPERATE THIS FIREPLACE WITH THE FLUE DAMPER IN THE CLOSED POSITION. COMBUSTION PRODUCTS MUST VENT UP THE CHIMNEY SYSTEM TO PREVENT CARBON MONOXIDE POISONING, AND TO PREVENT HOT COMBUSTION GASES FROM CONTACTING AND OVERHEATING COMBUSTIBLE SURFACES. FAILURE TO OPERATE THIS FIREPLACE WITH THE DAMPER IN THE OPEN POSITION MAY RESULT IN ASPHYXIATION OR A STRUCTURE FIRE.**

**CAUTION:**

**FIREPLACE OPERATION DOES REQUIRE AIR. DO NOT TAKE AIR FROM OTHER FUEL BURNING APPLIANCES WHICH CAN RESULT IN IMPROPER VENTING (SMOKING) OR AIR DILUTION. ALWAYS PROVIDE ADEQUATE MAKE-UP AIR.**

**STARTING THE FIRE.** Check the flue damper to be certain it is in the full open position. Place crumpled or twisted paper under the fireplace grate. Loosely arrange kindling and small pieces of wood to form a layer above the paper. Light the paper and add small pieces of wood until a hot bed of embers has been established. At this point, add progressively larger pieces of wood until you are able to position 4" diameter split logs as shown in Figure 25.

When first lighting your fireplace, it may be necessary to pre-warm the flue to establish a draft. This is done by holding a rolled up piece of burning newspaper under the flue damper for a few moments. This will prevent smoke spillage during start-up.

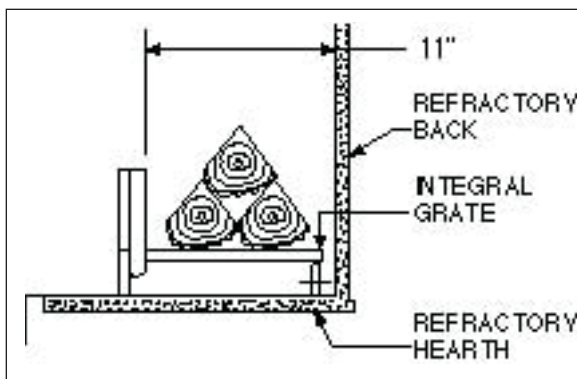

**Figure 25**  
**Sectional View of Fireplace**

Firewood should be seasoned for at least 6 months before it can be burned as a fireplace fuel. Improperly seasoned (green or wet) wood will cause the fireplace to smoke, will allow creosote deposits to rapidly buildup in the chimney system and may cause roof stains to develop.

Fuel products with abnormal burning characteristics, including synthetic logs that contain wax binders, scrap lumber, wax or plastic coated cardboard and other highly volatile fuels that burn at excessive temperatures, may cause the fireplace to operate in an unsafe manner. Flammable liquid fuels are explosive and must never be used to start or freshen a fire. Heat-N-Glo does not warrant the structural or functional performance of the fireplace system when such synthetic fuels or flammable liquids have been used.

**NOTE: When heated for the first several times, the fireplace should be heated gradually to prevent moisture in the refractory from causing cracks and to allow binders in the insulation to dissipate. You will notice an industrial odor during the first few fires that are burned. This is considered to be normal.**

Use only a solid wood fuel or a listed Heat-N-Glo gas log set. Do not use a fireplace insert or products not specifically tested and listed for use in this fireplace. Use common sense when burning this fireplace. The fire must be built on the fireplace grate, without danger of the burning fuel falling out of the firebox.

**CAUTION:**

**NEVER USE GASOLINE, GASOLINE-TYPE LANTERN FUEL, KEROSENE, CHARCOAL LIGHTER FLUID, OR SIMILAR LIQUIDS TO START OR 'FRESHEN UP' A FIRE IN THIS FIREPLACE. KEEP ALL SUCH LIQUIDS WELL AWAY FROM THE FIREPLACE WHILE IT IS IN USE TO AVOID THE RISK OF A HOSTILE FIRE.**

**DISPOSAL OF ASHES.** Ashes should be placed in a metal container with a tight-fitting lid. The closed container of ashes should be placed on a non-combustible floor or on the ground, well away from all combustible materials, pending final disposal. If the ashes are disposed of by burial in soil or otherwise locally dispersed, they should be retained in the closed container until all cinders have thoroughly cooled.

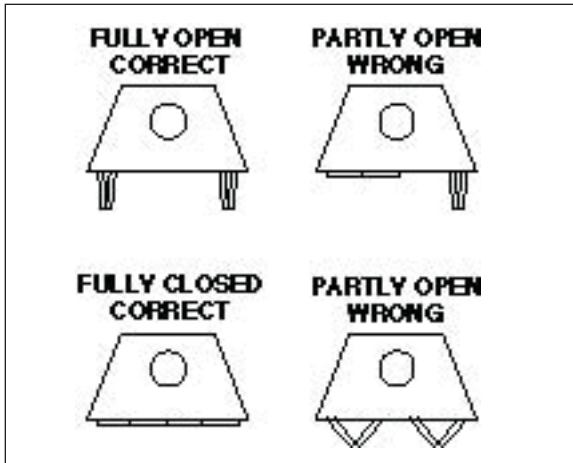

**Figure 26**  
Recommended Operating Positions of Doors

**GLASS DOORS.** Most efficient fireplace operation using glass doors is with the doors open. When the doors are open, the screen must be closed. Only glass doors, model numbers: DM1136, DM1136A, DM1136B, C1136A, C1136B, C1136C, C2136A, C2136B, C2136C or P1136B may be used on this fireplace.

Before starting a fire in your RHW-44 fireplace, use the following check list:

**FLUE DAMPER.** The flue damper is operated by pushing the handle up toward the top of the firebox, which should place the damper in a fully open position. Verify this by looking up from the inside of the firebox. Always operate this fireplace with the damper fully open. Please note, down drafts, obstructions, damage or poor (wet) fuels can cause smoke spillage.

**CHIMNEY INSPECTION.** Visually inspect the chimney internally for obstructions and construction damage. Flue pipe joints and seams must be continuous and mechanically tight. In a used chimney, additional inspection is needed for creosote build-up which is the formation of a flammable sediment.

When wood is burned slowly, it produces tar and other organic vapors, which combine with expelled moisture to form creosote. The creosote vapors condense in the relatively cool chimney flue of a slow-burning fire. As a result, creosote residue accumulates on the flue lining. When ignited, this creosote makes an extremely hot fire.

The chimney should be inspected at least twice a year during the heating season to determine if creosote build-up has occurred.

If creosote has accumulated, it should be removed to reduce the risk of a chimney fire.

**CHIMNEY CLEANING.** If you do detect a build-up of creosote, contact a qualified chimney sweep or clean it yourself. To do this, perform the following steps:

1. Open the damper.
2. Hang a damp sheet across the fireplace opening to stop dirt and soot from entering the room.
3. Remove the Terminal Cap or Housing Top. See Figure 27.
4. Clean with a stiff nylon brush attached to a pole **OR** tie a rope to a burlap bag filled with straw and several small stones or sand. Work up and down the flue until clean.
5. Replace the terminal cap or housing top.

**WARNING!**

**FIREPLACES EQUIPPED WITH DOORS SHOULD BE OPERATED ONLY WITH DOORS FULLY OPEN OR FULLY CLOSED. IF DOORS ARE LEFT PARTIALLY OPEN, GAS AND FLAME MAY BE DRAWN OUT OF THE FIREPLACE OPENING, CREATING THE RISK OF BOTH FIRE AND SMOKE.**

**WARNING!**

**CONTINUED OVER-FIRING CAN PERMANENTLY DAMAGE YOUR FIREPLACE SYSTEM. EXAMPLES OF OVER-FIRING ARE:**

1. THE "NORMAL LOG FIRE" SHOULD BE CONTAINED IN THE GRATE, WITH THE LENGTH OF LOGS NO GREATER THAN THE BACK WALL OF THE FIREPLACE.
2. THE FOLLOWING MATERIALS MUST NOT BE USED IN THIS FIREPLACE: QUANTITIES OF SCRAP LUMBER, PINE BRANCHES, PROCESSED FIRE LOGS AND FIRE STARTERS, OR CARDBOARD BOXES WHICH EXCEED THE VOLUME OF THE "NORMAL LOG FIRE". THESE MATERIALS PRODUCE MANY SPARKS AND MUST NOT BE USED.



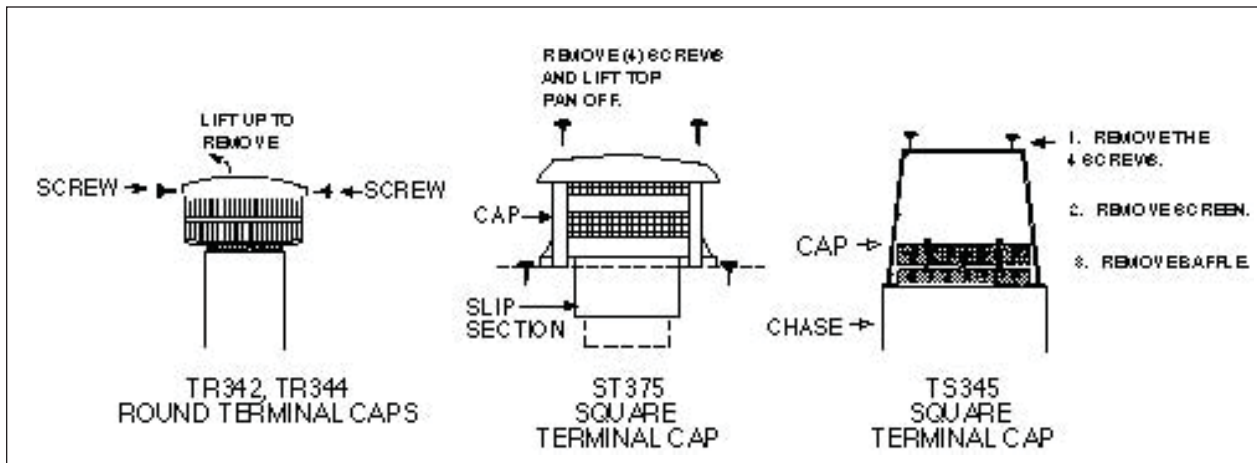

Figure 27 - Terminal Caps

**WARNING!**

**A CHIMNEY FIRE CAN PERMANENTLY DAMAGE YOUR CHIMNEY SYSTEM. THIS DAMAGE CAN ONLY BE REPAIRED BY REPLACING THE DAMAGED COMPONENT PARTS. CHIMNEY FIRES ARE NOT COVERED BY THE LIMITED WARRANTY AND BUYER PROTECTION PLAN.**

**CAUTION:**

**WHEN LEFT CLOSED WHILE BURNING YOUR FIREPLACE, FIRESCREENS AND GLASS DOORS WILL BE HOT. HANDLE WITH CARE.**

**CLEAR SPACE NEAR FIREPLACE.** The hearth extension must extend at least 16" to the front and 8 inches to the sides of the firebox opening. Combustible materials must not be stored in this area. Combustible walls perpendicular to the front of the fireplace must be at least 20" from the fireplace opening. Room furnishings such as drapes, curtains, chairs, or other combustibles must be at least 4 feet from the open front of the fireplace.

**GRATE.** The factory installed integral grate must be used to hold the logs from falling out of an open fireplace and to allow air to pass between the burning logs. It is important to keep the fire off the hearth and to allow the ashes to collect beneath the fire, thereby forming a layer of additional heat protection. See Figure 25. Use only model number GR8 integral grate for replacement.

**FIRESCREEN.** A firescreen is always provided to control sparks. It must be closed whenever the fireplace is in use. Glass doors or firescreens must not be used to hold burning material inside the fireplace. Only those glass door units specifically tested and listed for use with the specific fireplace model should be used. Screens should be closed when the glass doors are closed.

**NEGATIVE AIR PRESSURE WITHIN THE STRUCTURE.** This fireplace will operate correctly only if adequate ventilation is provided to allow proper draft to the fireplace system. Heat-N-Glo assumes no responsibility for the improper performance of the fireplace system caused by inadequate draft due to environmental conditions, downdrafts, tight sealing construction of the structure, or mechanical exhausting devices which create a negative air pressure within the structure where the fireplace is located.

**OUTSIDE AIR KIT OPERATION.** A damper control handle allows the individual control of the outside air inlets if your fireplace is equipped with this option. Use of outside air for combustion is highly recommended to conserve heated air within the structure and to provide make up air to keep the fireplace venting properly.

## **WARRANTY FOR HEAT-N-GLO FIREPLACES**

**The limited warranty will not become effective until you have mailed the completed warranty card to HEAT-N-GLO,  
A DIVISION OF HEARTH TECHNOLOGIES INC., 20802 Kensington Blvd., Lakeville, MN 55044.  
This card must be mailed within 60 days of the fireplace installation.**

Subject to the conditions set forth herein, Heat-N-Glo extends the following limited warranty with respect to your Heat-N-Glo fireplace, excluding accessories, Chimney components and Glass Doors.

If Heat-N-Glo is satisfied that any part or portion of the fireplace covered by this warranty is defective in material or workmanship under normal use and service as described in the operating instructions, Heat-N-Glo will take the following actions:

1. Within the first five (5) years from the date of installation, Heat-N-Glo shall, at its option, replace or repair any such defect in material or workmanship, at Heat-N-Glo's expense. HEAT-N-GLO SHALL NOT BE RESPONSIBLE FOR ANY OTHER LABOR COSTS, OR EXPENSES, INCLUDING INDIRECT, INCIDENTAL OR CONSEQUENTIAL DAMAGES.
2. During the sixth (6th) through the (10th) years after the date of installation, Heat-N-Glo shall supply replacement parts or parts at no charge, but SHALL NOT BE RESPONSIBLE FOR ANY LABOR, TRANSPORTATION, OR OTHER INDIRECT DAMAGES.
3. During the eleventh (11th) through the fifteenth (15th) years after date of installation, Heat-N-Glo will send to you, FOB its factory, replacement parts (if available) at the current minimum wholesale price, but Heat-N-Glo SHALL NOT BE RESPONSIBLE FOR ANY LABOR, TRANSPORTATION OR OTHER INDIRECT DAMAGES.
4. During the first six (6) months after installation, HEAT-N-GLO shall, at its option, replace or repair the Glass Doors and any electrical components, if operation is faulty. (This does not include Glass panels broken during shipment, misuse or careless handling.) After the first six (6) months, HEAT-N-GLO will sell to you, FOB its factory, replacement parts at the current list price, but HEAT-N-GLO SHALL NOT BE RESPONSIBLE FOR ANY LABOR, TRANSPORTATION OR OTHER INDIRECT DAMAGES. IF GLASS DOORS OTHER THAN FACTORY DOORS ARE USED ALL WARRANTY AND LIABILITY ON THE FIREPLACE IS VOIDED.

Heat-N-Glo may discharge its entire warranty liability by refunding the price of the product.

Products made by other manufacturers, sold with the fireplace or thereafter are not covered by this limited warranty.

This limited warranty will be void if the fireplace is not installed according to the installation instructions. The limited warranty also is void if the fireplace is not operated, at all times, according to the operating instructions furnished. The limited warranty will also be void if the fireplace is removed from the place originally installed.

EXCEPT TO THE EXTENT PROVIDED BY LAW, NO IMPLIED WARRANTIES OF MERCHANTABILITY OR FITNESS FOR A PARTICULAR PURPOSE, AND NO IMPLIED WARRANTIES SHALL APPLY TO THE FIREPLACE AFTER THE ABOVE LIMITED WARRANTY HAS EXPIRED.

In states that do not allow limitations on how long implied warranty lasts, or do not allow exclusion of indirect damages, those limitations or exclusions may not apply to you. You may also have additional rights not covered in this limited warranty.

HEAT-N-GLO reserves the right to make changes at anytime, without notice, in design, material, specifications and prices and the right to discontinue styles and products.

- UNDERWRITERS LABORATORIES FILE NO. MH5850

