

Model: GATEWAY

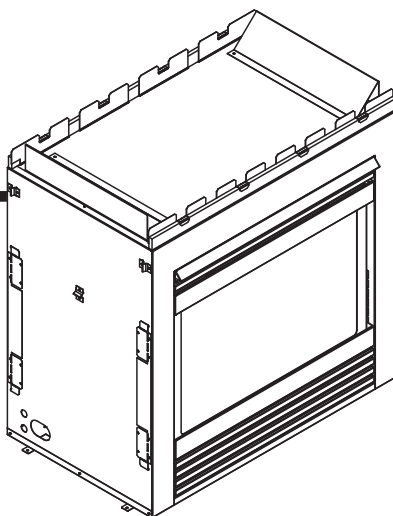

NOTICE



DO NOT DISCARD THIS MANUAL

- Important operating and maintenance instructions included.
- Read, understand and follow these instructions for safe installation and operation.
- Leave this manual with party responsible for use and operation.



⚠ WARNING: If the information in these instructions is not followed exactly, a fire or explosion may result causing property damage, personal injury, or death.

- **DO NOT** store or use gasoline or other flammable vapors and liquids in the vicinity of this or any other appliance.
- **What to do if you smell gas**
 - **DO NOT** try to light any appliance.
 - **DO NOT** touch any electrical switch. **DO NOT** use any phone in your building.
 - Immediately call your gas supplier from a neighbor's phone. Follow the gas supplier's instructions.
 - If you cannot reach your gas supplier, call the fire department.
- Installation and service must be performed by a qualified installer, service agency, or the gas supplier.

⚠ WARNING



HOT SURFACES!

Glass and other surfaces are hot during operation AND cool down.

Hot glass will cause burns.

- **DO NOT** touch glass until it is cooled
 - NEVER allow children to touch glass
 - Keep children away
 - CAREFULLY SUPERVISE children in same room as fireplace.
 - Alert children and adults to hazards of high temperatures.
- High temperatures may ignite clothing or other flammable materials.**
- Keep clothing, furniture, draperies and other flammable materials away.

This appliance has been supplied with an integral barrier to prevent direct contact with the fixed glass panel. DO NOT operate the appliance with the barrier removed.

Contact your dealer or Hearth & Home Technologies if the barrier is not present or help is needed to properly install one.

In the Commonwealth of Massachusetts installation must be performed by a licensed plumber or gas fitter.

A CO detector shall be installed in the room where the appliance is installed.



Installation and service of this appliance should be performed by qualified personnel. Hearth & Home Technologies suggests NFI certified or factory trained professionals, or technicians supervised by an NFI certified professional.

Read this manual before installing or operating this appliance.
Please retain this owner's manual for future reference.

A. Congratulations

Congratulations on selecting a Heat & Glo gas fireplace, an elegant and clean alternative to wood burning fireplaces. The Heat & Glo gas fireplace you have selected is designed to provide the utmost in safety, reliability, and efficiency.

As the owner of a new fireplace, you'll want to read and carefully follow all of the instructions contained in this owner's manual. Pay special attention to all cautions and warnings.

This owner's manual should be retained for future reference. We suggest that you keep it with your other important documents and product manuals.

The information contained in this owner's manual, unless noted otherwise, applies to all models and gas control systems.

Your new Heat & Glo gas fireplace will give you years of durable use and trouble-free enjoyment. Welcome to the Heat & Glo family of fireplace products!

Homeowner Reference Information	<i>We recommend that you record the following pertinent information about your fireplace.</i>
Model Name: _____	Date purchased/installed: _____
Serial Number: _____	Location on fireplace: _____
Dealership purchased from: _____	Dealer Phone: _____
Notes: _____	

Listing Label Information/Location

The model information regarding your specific fireplace can be found on the rating plate usually located in the control area of the fireplace.

Type of Gas →

Gas and Electric Information →

HEAT & GLO
No one builds a better fire

Heat & Glo, a brand of Hearth & Home Technologies
7571 215th Street West, Lakeville, MN 55044

Not for use with solid fuel.
(Ne doit pas être utilisé avec un combustible solide).

Type of Gas (Sorte De Gaz): **NATURAL GAS**

This appliance must be installed in accordance with local codes, if any; if not, follow ANSI Z223.1 in the USA or CAN/CGA B149 installation codes. (Installer l'appareil selon les codes ou règlements locaux ou, en l'absence de tels règlements, selon les codes d'installation CAN/CGA-B149.)

ANSI Z21XX-XXXX · CSA 2.XX-MXX

Minimum Permissible Gas Supply for Purposes of Input Adjustment.

Approved Minimum (De Gaz) Acceptable	0.0 in w.c.	(Po. Col. d'eau)
Maximum Pressure (Pression)	0.0 in w.c.	(Po. Col. d'eau)
Maximum Manifold Pressure (Pression)	0.0 in w.c.	(Po. Col. d'eau)
Minimum Manifold Pressure (Pression)	0.0 in w.c.	(Po. Col. d'eau)

Total Electrical Requirements: 000Vac, 00Hz., less than 00 Amperes

GAS-FIRED



ALTITUDE:	0-0000 FT.	IN CANADA	0000-0000FT.
MAX. INPUT BTUH:	00,000		00,000
MIN. INPUT BTUH:	00,000		00,000
ORIFICE SIZE:	#XXXXXX		#XXXXXX

Model: (Modele): **XXXXXXXXXX**

Serial (Serie): **XXXXXXXXXX**

Model Number →

Serial Number →

▲ Safety Alert Key:

- **DANGER!** Indicates a hazardous situation which, if not avoided will result in death or serious injury.
- **WARNING!** Indicates a hazardous situation which, if not avoided could result in death or serious injury.
- **CAUTION!** Indicates a hazardous situation which, if not avoided, could result in minor or moderate injury.
- **NOTICE:** Used to address practices not related to personal injury.

Table of Contents

A. Congratulations 2

→ B. Limited Lifetime Warranty 5

1 Listing and Code Approvals

A. Appliance Certification 7

B. Glass Specifications 7

C. BTU Specifications 7

D. High Altitude Installations 7

E. Non-Combustible Materials Specification 7

F. Combustible Materials Specification 7

G. Electrical Codes 7

H. Requirements for the Commonwealth of Massachusetts . . 8

User Guide

2 Operating Instructions

A. Gas Fireplace Safety 9

B. Your Fireplace 9

C. Fan Kit (optional) 10

D. Clear Space 10

E. Decorative Doors and Fronts 10

F. Fixed Glass Assembly 10

G. Remote Controls, Wall Controls and Wall Switches 10

H. Outside Air Kit 10

I. Before Lighting Fireplace 10

J. Lighting Instructions (IPI) 11

K. After Fireplace is Lit 12

L. Frequently Asked Questions 12

3 Maintenance and Service

A. Maintenance Tasks-Homeowner 13

B. Maintenance Tasks-Qualified Service Technician 14

Installer Guide

4 Getting Started

A. Typical Appliance System 15

B. Design and Installation Considerations 16

C. Tools and Supplies Needed 16

D. Inspect Appliance and Components 16

E. Negative Pressure 17

5 Framing and Clearances

A. Selecting Appliance Location 18 ←

B. Constructing the Appliance Chase 19

C. Clearances 19

D. Mantel and Wall Projections 20

6 Termination Locations

A. Vent Termination Minimum Clearances 21

7 Vent Information and Diagrams

A. Vent Guidelines 23

B. Vent System Configuration 23

8 Vent Clearances and Framing

A. Pipe Clearances to Combustibles 27

B. Install Support Brackets 27

C. Install Wall Shield Firestops 28

D. Vent Termination 29

9 Appliance Preparation

A. Installing Outside Air Kit Damper Assembly (Optional) . . 30

B. Gas and Electrical Connections 30

C. Securing and Leveling the Appliance 31

10 Installing Vent Pipe

A. Assembly of Vent Sections 32

B. Attaching Vent to Firebox 32

C. Securing Vent Sections (B-Type Vent) 32

D. Securing Vent Sections (PV-FLEX) 32

11 Gas Information

A. Fuel Conversion 33

B. Gas Pressure 33

C. Gas Connection 33

D. High Altitude Installations 33

12 Electrical Information ←

A. Wiring Requirements 34

B. IntelliFire Ignition System Wiring 34

C. Optional Accessories Requirements 34

D. Electrical Service and Repair 35

E. Junction Box Installation 36

13 Finishing

A. Mantel and Wall Projections	37
B. Facing Material	37

14 Appliance Setup

A. Remove Glass Assembly	38
B. Remove Shipping Materials	38
C. Remove Grate Shipping Support	38
D. Clean the Appliance	38
E. Accessories	38
F. Ember Placement	38
G. Positioning the Logs	39
H. Fixed Glass Assembly	41
I. Install the Mesh	41
J. Install Trim and/or Surround	41
K. Install Hood	41
L. Air Shutter Setting	41

15 Troubleshooting

➔ A. IntelliFire Ignition System	42
--	----

16 Reference Materials

A. Appliance Dimension Diagram	44
B. Vent Components Diagrams	45
➔ D. Contact Information	49

➔ = Contains updated information.

→ B. Limited Lifetime Warranty

**Hearth & Home Technologies
LIMITED LIFETIME WARRANTY**

Hearth & Home Technologies, on behalf of its hearth brands ("HHT"), extends the following warranty for HHT gas, wood, pellet, coal and electric hearth appliances that are purchased from an HHT authorized dealer.

WARRANTY COVERAGE:

HHT warrants to the original owner of the HHT appliance at the site of installation, and to any transferee taking ownership of the appliance at the site of installation within two years following the date of original purchase, that the HHT appliance will be free from defects in materials and workmanship at the time of manufacture. After installation, if covered components manufactured by HHT are found to be defective in materials or workmanship during the applicable warranty period, HHT will, at its option, repair or replace the covered components. HHT, at its own discretion, may fully discharge all of its obligations under such warranties by replacing the product itself or refunding the verified purchase price of the product itself. The maximum amount recoverable under this warranty is limited to the purchase price of the product. This warranty is subject to conditions, exclusions and limitations as described below.

WARRANTY PERIOD:

Warranty coverage begins on the date of original purchase. In the case of new home construction, warranty coverage begins on the date of first occupancy of the dwelling or six months after the sale of the product by an independent, authorized HHT dealer/ distributor, whichever occurs earlier. The warranty shall commence no later than 24 months following the date of product shipment from HHT, regardless of the installation or occupancy date. The warranty period for parts and labor for covered components is produced in the following table.

The term "Limited Lifetime" in the table below is defined as: 20 years from the beginning date of warranty coverage for gas appliances, and 10 years from the beginning date of warranty coverage for wood, pellet, and coal appliances. These time periods reflect the minimum expected useful lives of the designated components under normal operating conditions.

Warranty Period		HHT Manufactured Appliances and Venting							Components Covered
Parts	Labor	Gas	Wood	Pellet	EPA Wood	Coal	Electric	Venting	
1 Year		X	X	X	X	X	X	X	All parts and material except as covered by Conditions, Exclusions, and Limitations listed
2 years				X	X	X			Igniters, electronic components, and glass
		X	X	X	X	X			Factory-installed blowers
			X						Molded refractory panels
3 years				X					Firepots and burnpots
5 years	1 year			X	X				Castings and baffles
7 years	3 years		X	X	X				Manifold tubes, HHT chimney and termination
10 years	1 year	X							Burners, logs and refractory
Limited Lifetime	3 years	X	X	X	X	X			Firebox and heat exchanger
90 Days		X	X	X	X	X	X	X	All replacement parts beyond warranty period

See conditions, exclusions, and limitations on next page.

→ B. Limited Lifetime Warranty (*continued*)

WARRANTY CONDITIONS:

- This warranty only covers HHT appliances that are purchased through an HHT authorized dealer or distributor. A list of HHT authorized dealers is available on the HHT branded websites.
- This warranty is only valid while the HHT appliance remains at the site of original installation.
- This warranty is only valid in the country in which the HHT authorized dealer or distributor that sold the appliance resides.
- Contact your installing dealer for warranty service. If the installing dealer is unable to provide necessary parts, contact the nearest HHT authorized dealer or supplier. Additional service fees may apply if you are seeking warranty service from a dealer other than the dealer from whom you originally purchased the product.
- Check with your dealer in advance for any costs to you when arranging a warranty call. Travel and shipping charges for parts are not covered by this warranty.

WARRANTY EXCLUSIONS:

This warranty does not cover the following:

- Changes in surface finishes as a result of normal use. As a heating appliance, some changes in color of interior and exterior surface finishes may occur. This is not a flaw and is not covered under warranty.
- Damage to printed, plated, or enameled surfaces caused by fingerprints, accidents, misuse, scratches, melted items, or other external sources and residues left on the plated surfaces from the use of abrasive cleaners or polishes.
- Repair or replacement of parts that are subject to normal wear and tear during the warranty period. These parts include: paint, wood, pellet and coal gaskets, firebricks, grates, flame guides, batteries and the discoloration of glass.
- Minor expansion, contraction, or movement of certain parts causing noise. These conditions are normal and complaints related to this noise are not covered by this warranty.
- Damages resulting from: (1) failure to install, operate, or maintain the appliance in accordance with the installation instructions, operating instructions, and listing agent identification label furnished with the appliance; (2) failure to install the appliance in accordance with local building codes; (3) shipping or improper handling; (4) improper operation, abuse, misuse, continued operation with damaged, corroded or failed components, accident, or improperly/incorrectly performed repairs; (5) environmental conditions, inadequate ventilation, negative pressure, or drafting caused by tightly sealed constructions, insufficient make-up air supply, or handling devices such as exhaust fans or forced air furnaces or other such causes; (6) use of fuels other than those specified in the operating instructions; (7) installation or use of components not supplied with the appliance or any other components not expressly authorized and approved by HHT; (8) modification of the appliance not expressly authorized and approved by HHT in writing; and/or (9) interruptions or fluctuations of electrical power supply to the appliance.
- Non-HHT venting components, hearth components or other accessories used in conjunction with the appliance.
- Any part of a pre-existing fireplace system in which an insert or a decorative gas appliance is installed.
- HHT's obligation under this warranty does not extend to the appliance's capability to heat the desired space. Information is provided to assist the consumer and the dealer in selecting the proper appliance for the application. Consideration must be given to appliance location and configuration, environmental conditions, insulation and air tightness of the structure.

This warranty is void if:

- The appliance has been over-fired or operated in atmospheres contaminated by chlorine, fluorine, or other damaging chemicals. Over-firing can be identified by, but not limited to, warped plates or tubes, rust colored cast iron, bubbling, cracking and discoloration of steel or enamel finishes.
- The appliance is subjected to prolonged periods of dampness or condensation.
- There is any damage to the appliance or other components due to water or weather damage which is the result of, but not limited to, improper chimney or venting installation.

LIMITATIONS OF LIABILITY:

- The owner's exclusive remedy and HHT's sole obligation under this warranty, under any other warranty, express or implied, or in contract, tort or otherwise, shall be limited to replacement, repair, or refund, as specified above. In no event will HHT be liable for any incidental or consequential damages caused by defects in the appliance. Some states do not allow exclusions or limitation of incidental or consequential damages, so these limitations may not apply to you. This warranty gives you specific rights; you may also have other rights, which vary from state to state. EXCEPT TO THE EXTENT PROVIDED BY LAW, HHT MAKES NO EXPRESS WARRANTIES OTHER THAN THE WARRANTY SPECIFIED HEREIN. THE DURATION OF ANY IMPLIED WARRANTY IS LIMITED TO DURATION OF THE EXPRESSED WARRANTY SPECIFIED ABOVE.

1 Listing and Code Approvals

A. Appliance Certification

MODEL: GATEWAY
LABORATORY: Underwriters Laboratories, Inc. (UL)
TYPE: B-Vent Gas Appliance
STANDARD: ANSI Z21.50b-2009 • CSA 2.22b-2009

This product is listed to ANSI standards for “Vented Gas Fireplaces” and “Gas Fired Appliances for Use at High Altitudes”.

May be installed in a sleeping room when the provisions for combustion, ventilation and dilution air are met per the requirements of **ANSI Z23.1/NFPA 54 National Fuel Gas Code**. In Canada, installation in a sleeping room requires installation with a thermostat certified for use with this product. Consult your local authorities having jurisdiction.

NOTICE: *This installation must conform with local codes. In the absence of local codes you must comply with the National Fuel Gas Code, ANSI Z223.1-latest edition in the U.S.A. and the CAN/CGA B149 Installation Codes in Canada.*

NOT INTENDED FOR USE AS A PRIMARY HEAT SOURCE.
 This appliance is tested and approved as either supplemental room heat or as a decorative appliance. It should not be factored as primary heat in residential heating calculations.

B. Glass Specifications

Hearth & Home Technologies appliances manufactured with tempered glass may be installed in hazardous locations such as bathtub enclosures as defined by the Consumer Product Safety Commission (CPSC). The tempered glass has been tested and certified to the requirements of **ANSI Z97.1** and **CPSC 16 CFR 1202** (Safety Glazing Certification Council **SGCC# 1595** and **1597**. Architectural Testing, Inc. Reports **02-31919.01** and **02-31917.01**).

This statement is in compliance with **CPSC 16 CFR Section 1201.5** “Certification and labeling requirements” which refers to **15 U.S. Code (USC) 2063** stating “...Such certificate shall accompany the product or shall otherwise be furnished to any distributor or retailer to whom the product is delivered.”

Some local building codes require the use of tempered glass with permanent marking in such locations. Glass meeting this requirement is available from the factory. Please contact your dealer or distributor to order.

C. BTU Specifications

Models (U.S. or Canada)	Maximum Input BTU/h	Orifice Size (DMS)	
Gateway (NG)	US (0-2000 FT)	35,000	32
	CANADA (2000-4500 FT)	31,500	33
Gateway (LP)	US (0-2000 FT)	33,500	50
	CANADA (2000-4500 FT)	30,150	51

D. High Altitude Installations

NOTICE: *If the heating value of the gas has been reduced, these rules do not apply. Check with your local gas utility or authorities having jurisdiction.*

When installing above 2000 feet elevation:

- In the USA: Reduce input rate 4% for each 1000 feet above 2000 feet.
- In CANADA: Reduce input rate 10% for elevations between 2000 feet and 4500 feet. Above 4500 feet, consult local gas utility.

Check with your local gas utility to determine proper orifice size.

E. Non-Combustible Materials Specification

Material which will not ignite and burn. Such materials are those consisting entirely of steel, iron, brick, tile, concrete, slate, glass or plasters, or any combination thereof.

Materials that are reported as passing **ASTM E 136, Standard Test Method for Behavior of Materials in a Vertical Tube Furnace at 750 °C** shall be considered non-combustible materials.

F. Combustible Materials Specification

Materials made of or surfaced with wood, compressed paper, plant fibers, plastics, or other material that can ignite and burn, whether flame proofed or not, or plastered or unplastered shall be considered combustible materials.

G. Electrical Codes

NOTICE: *This appliance must be electrically wired and grounded in accordance with local codes or, in the absence of local codes, with National Electric Code ANSI/NFPA 70-latest edition or the Canadian Electric Code CSA C22.1.*

- A 110-120 VAC circuit for this product must be protected with ground-fault circuit-interrupter protection, in compliance with the applicable electrical codes, when it is installed in locations such as in bathrooms or near sinks.

Note: The following requirements reference various Massachusetts and national codes not contained in this document.

H. Requirements for the Commonwealth of Massachusetts

For all side wall horizontally vented gas fueled equipment installed in every dwelling, building or structure used in whole or in part for residential purposes, including those owned or operated by the Commonwealth and where the side wall exhaust vent termination is less than seven (7) feet above finished grade in the area of the venting, including but not limited to decks and porches, the following requirements shall be satisfied:

Installation of Carbon Monoxide Detectors

At the time of installation of the side wall horizontal vented gas fueled equipment, the installing plumber or gas fitter shall observe that a hard wired carbon monoxide detector with an alarm and battery back-up is installed on the floor level where the gas equipment is to be installed. In addition, the installing plumber or gas fitter shall observe that a battery operated or hard wired carbon monoxide detector with an alarm is installed on each additional level of the dwelling, building or structure served by the side wall horizontal vented gas fueled equipment. It shall be the responsibility of the property owner to secure the services of qualified licensed professionals for the installation of hard wired carbon monoxide detectors.

In the event that the side wall horizontally vented gas fueled equipment is installed in a crawl space or an attic, the hard wired carbon monoxide detector with alarm and battery back-up may be installed on the next adjacent floor level.

In the event that the requirements of this subdivision can not be met at the time of completion of installation, the owner shall have a period of thirty (30) days to comply with the above requirements; provided, however, that during said thirty (30) day period, a battery operated carbon monoxide detector with an alarm shall be installed.

Approved Carbon Monoxide Detectors

Each carbon monoxide detector as required in accordance with the above provisions shall comply with NFPA 720 and be ANSI/UL 2034 listed and IAS certified.

Signage

A metal or plastic identification plate shall be permanently mounted to the exterior of the building at a minimum height of eight (8) feet above grade directly in line with the exhaust vent terminal for the horizontally vented gas fueled heating appliance or equipment. The sign shall read, in print size no less than one-half (1/2) inch in size, "**GAS VENT DIRECTLY BELOW. KEEP CLEAR OF ALL OBSTRUCTIONS**".

Inspection

The state or local gas inspector of the side wall horizontally vented gas fueled equipment shall not approve the installation unless, upon inspection, the inspector observes carbon monoxide detectors and signage installed in accordance with the provisions of 248 CMR 5.08(2)(a)1 through 4.

Exemptions

The following equipment is exempt from 248 CMR 5.08(2)(a)1 through 4:

- The equipment listed in Chapter 10 entitled "Equipment Not Required To Be Vented" in the most current edition of NFPA 54 as adopted by the Board; and
- Product Approved side wall horizontally vented gas fueled equipment installed in a room or structure separate from the dwelling, building or structure used in whole or in part for residential purposes.

MANUFACTURER REQUIREMENTS

Gas Equipment Venting System Provided

When the manufacturer of Product Approved side wall horizontally vented gas equipment provides a venting system design or venting system components with the equipment, the instructions provided by the manufacturer for installation of the equipment and the venting system shall include:

- Detailed instructions for the installation of the venting system design or the venting system components; and
- A complete parts list for the venting system design or venting system.

Gas Equipment Venting System **NOT** Provided

When the manufacturer of a Product Approved side wall horizontally vented gas fueled equipment does not provide the parts for venting the flue gases, but identifies "special venting systems", the following requirements shall be satisfied by the manufacturer:

- The referenced "special venting system" instructions shall be included with the appliance or equipment installation instructions; and
- The "special venting systems" shall be Product Approved by the Board, and the instructions for that system shall include a parts list and detailed installation instructions.

A copy of all installation instructions for all Product Approved side wall horizontally vented gas fueled equipment, all venting instructions, all parts lists for venting instructions, and/or all venting design instructions shall remain with the appliance or equipment at the completion of the installation.

See Gas Connection section for additional Commonwealth of Massachusetts requirements.

A. Gas Fireplace Safety

⚠ WARNING



HOT SURFACES!

Glass and other surfaces are hot during operation AND cool down.

Hot glass will cause burns.

- DO NOT touch glass until it is cooled
- NEVER allow children to touch glass
- Keep children away

- CAREFULLY SUPERVISE children in same room as fireplace.
- Alert children and adults to hazards of high temperatures.

High temperatures may ignite clothing or other flammable materials.

- Keep clothing, furniture, draperies and other flammable materials away.

This appliance has been supplied with an integral barrier to prevent direct contact with the fixed glass panel. DO NOT operate the appliance with the barrier removed.

Contact your dealer or Hearth & Home Technologies if the barrier is not present or help is needed to properly install one.

If you expect that small children or vulnerable adults may come into contact with this fireplace, the following precautions are recommended:

- Install a physical barrier such as:
 - A decorative firescreen.
 - Adjustable safety gate.
- Install a switch lock or a wall/remote control with child protection lockout feature.

- Keep remote controls out of reach of children.
- Never leave children alone near a hot fireplace, whether operating or cooling down.
- Teach children to NEVER touch the fireplace.
- Consider not using the fireplace when children will be present.

Contact your dealer for more information, or visit: www.hpba.org/safety-information.

To prevent unintended operation when not using your fireplace for an extended period of time (summer months, vacation, trips, etc):

- Remove batteries from remote controls.
- Turn off wall controls.
- Unplug 3 volt adapter plug on IPI models.
- Turn off gas controls valve on standing pilot models.

B. Your Fireplace

WARNING! DO NOT operate fireplace before reading and understanding operating instructions. Failure to operate fireplace according to operating instructions could cause fire or injury.

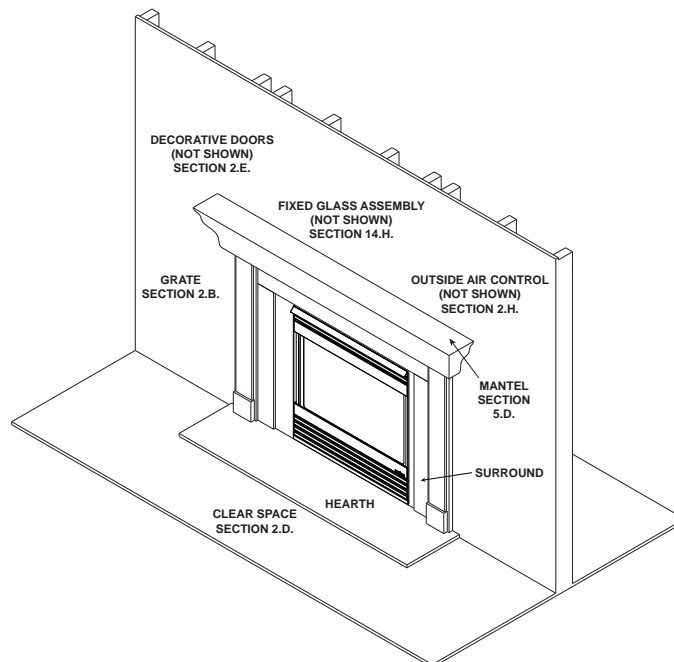

Figure 2.1 General Operating Parts

C. Fan Kit (optional)

If desired, a fan kit may be added. Contact your dealer to order the correct fan kit.

D. Clear Space

WARNING! DO NOT place combustible objects in front of the fireplace or block louvers. High temperatures may start a fire. See Figure 2.2.

Avoid placing candles and other heat-sensitive objects on mantel or hearth. Heat may damage these objects.

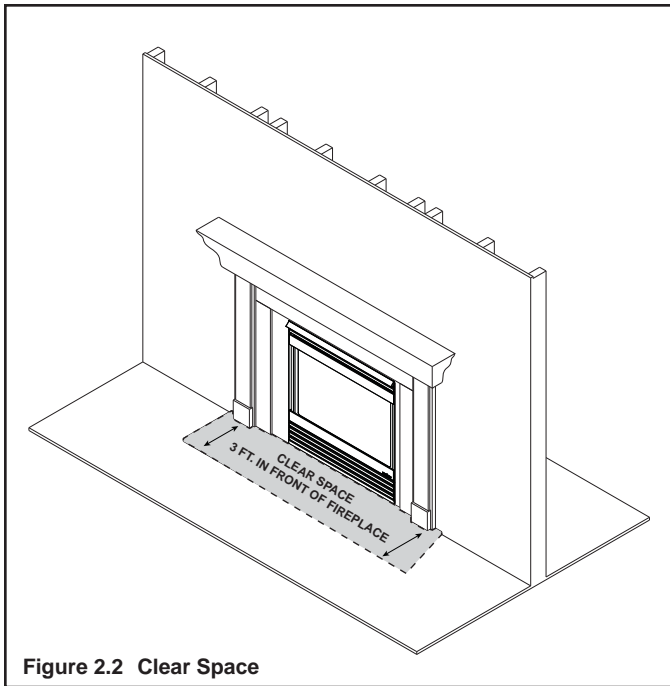

Figure 2.2 Clear Space

E. Decorative Doors and Fronts

WARNING! Risk of Fire! Install **ONLY** doors or fronts approved by Hearth & Home Technologies. Unapproved doors or fronts may cause fireplace to overheat.

This fireplace has been supplied with an integral barrier to prevent direct contact with the fixed glass panel. DO NOT operate the fireplace with the barrier removed.

Contact your dealer or Hearth & Home Technologies if the barrier is not present or help is needed to properly install one.

For more information refer to the instructions supplied with your decorative door or front.

F. Fixed Glass Assembly

See Section 14.H.

G. Remote Controls, Wall Controls and Wall Switches

Follow the instructions supplied with the control installed to operate your fireplace:

For safety:

- Install a switch lock or a wall/remote control with child protection lockout feature.
- Keep remote controls out of reach of children.

See your dealer if you have questions.

H. Outside Air Kit

This unit is equipped to accept outside air. **It is recommended that an AK-TV air kit be used with this appliance.** By using outside make-up air, the amount of room air used for combustion will be reduced. However, in a negative pressure condition the outside air kit **MUST** be installed to obtain proper performance and to help prevent spillage of combustion gases.

- Refer to Figure 2.1 for location of control.
- Close the inlet to prevent cold drafts when the fireplace is not being used.

CAUTION! Risk of Burns! The outside air control handle is **HOT** when fireplace is in operation. Adjust **BEFORE** lighting fire.

I. Before Lighting Fireplace

Before operating this fireplace for the first time, **have a qualified service technician:**

- Verify all shipping materials have been removed from inside and/or underneath the firebox.
- Review proper placement of logs, ember material and/or other decorative materials.
- Check the wiring.
- Check the air shutter adjustment.
- Ensure that there are no gas leaks.
- Ensure that the glass is sealed and in the proper position and that the integral barrier is in place.

WARNING! Risk of Fire/Asphyxiation! DO NOT operate fireplace with fixed glass assembly removed.

J. Lighting Instructions (IPI)

FOR YOUR SAFETY READ BEFORE LIGHTING

WARNING: If you do not follow these instructions exactly, a fire or explosion may result causing property damage, personal injury or loss of life.

- A.** This appliance is equipped with an intermittent pilot ignition (IPI) device which automatically lights the burner. **DO NOT** try to light the burner by hand.
- Immediately call your gas supplier from a neighbor's phone. Follow the gas supplier's instructions.
 - If you cannot reach your gas supplier, call the fire department.

- B. BEFORE LIGHTING,** smell all around the appliance area for gas. Be sure to smell next to the floor because some gas is heavier than air and will settle on the floor.
- C. DO NOT** use this appliance if any part has been under water. Immediately call a qualified service technician to inspect the appliance and to replace any part of the control system and any gas control which has been under water.

WHAT TO DO IF YOU SMELL GAS

- **DO NOT** try to light any appliance.
- **DO NOT** touch any electric switch; do not use any phone in your building.

WARNING:

DO NOT CONNECT LINE VOLTAGE (110/120 VAC OR 220/240 VAC) TO THE CONTROL VALVE.

Improper installation, adjustment, alteration, service or maintenance can cause injury or property damage. Refer to the owner's information manual provided with this appliance.

This appliance needs fresh air for safe operation and must be installed so there are provisions for adequate combustion and ventilation air.

If not installed, operated, and maintained in accordance with the manufacturer's instructions, this product could expose you to substances in fuel or fuel combustion which are known to the State of California to cause cancer, birth defects, or other reproductive harm.

Keep burner and control compartment clean. See installation and operating instructions accompanying appliance.

For additional information on operating your
Hearth & Home Technologies fireplace, please refer to www.fireplaces.com.

CAUTION:

Hot while in operation. **DO NOT** touch. Keep children, clothing, furniture, gasoline and other liquids having flammable vapors away.

DO NOT operate the appliance with fixed glass assembly removed, cracked or broken. Replacement of the fixed glass assembly should be done by a licensed or qualified service person.

NOT FOR USE WITH SOLID FUEL

For use with natural gas and propane. A conversion kit, as supplied by the manufacturer, shall be used to convert this appliance to the alternate fuel.

Also Certified for Installation in a Bedroom or a Bedsitting Room.

For assistance or additional information, consult a qualified installer, service agency or the gas supplier.

LIGHTING INSTRUCTIONS (IPI)

1. This appliance is equipped with an ignition device which automatically lights the burner. **DO NOT** try to light the burner by hand.

**GAS
VALVE**

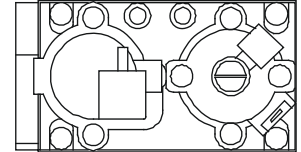

2. Wait five (5) minutes to clear out any gas. Then smell for gas, including near the floor. If you smell gas, **STOP!** Follow "B" in the Safety Information located on the left side of this label. If you do not smell gas, go to next step.

3. To light the burner:

Equipped with wall switch: Turn ON/OFF switch to ON.

Equipped with remote or wall control: Press ON or FLAME button.

Equipped with thermostat: Set temperature to desired setting.

4. If the appliance does not light after three tries, call your service technician or gas supplier.

TO TURN OFF GAS TO APPLIANCE

1. Equipped with wall switch: Turn ON/OFF switch to OFF.

Equipped with remote or wall control: Press OFF button.

Equipped with thermostat: Set temperature to lowest setting.

2. Service technician should turn off electric power to the control when performing service.

593-913G

Final inspection by _____

K. After Fireplace is Lit

Initial Break-in Procedure

- The fireplace should be run three to four hours continuously on high.
- Turn the fireplace off and allow it to completely cool.
- Remove fixed glass assemblies. See Section 14.J.
- Clean fixed glass assemblies. See Section 3.
- Replace the fixed glass assemblies and run continuously on high an additional 12 hours.

This cures the materials used to manufacture the fireplace.

NOTICE! Open windows for air circulation during fireplace break-in.

- *Some people may be sensitive to smoke and odors.*
- *Smoke detectors may activate.*

L. Frequently Asked Questions

ISSUE	SOLUTIONS
Condensation on the glass	This is a result of gas combustion and temperature variations. As the appliance warms, this condensation will disappear.
Blue flames	This is a result of normal operation and the flames will begin to yellow as the appliance is allowed to burn for 20 to 40 minutes.
Odor from appliance	When first operated, this appliance may release an odor for the first several hours. This is caused by the curing of the paint and the burning off of any oils remaining from manufacturing. Odor may also be released from finishing materials and adhesives used around the appliance.
Film on the glass	This is a normal result of the curing process of the paint and logs. Glass should be cleaned within 3 to 4 hours of initial burning to remove deposits left by oils from the manufacturing process. A non-abrasive cleaner such as gas fireplace glass cleaner may be necessary. See your dealer.
Metallic noise	Noise is caused by metal expanding and contracting as it heats up and cools down, similar to the sound produced by a furnace or heating duct. This noise does not affect the operation or longevity of the appliance.

3 Maintenance and Service

Any safety screen or guard removed for servicing must be replaced prior to operating the fireplace.

When properly maintained, your fireplace will give you many years of trouble-free service. We recommend annual service by a qualified service technician.

A. Maintenance Tasks-Homeowner

Installation and repair should be done by a qualified service technician only. The fireplace should be inspected before use and at least annually by a professional service person.

The following tasks may be performed annually by the homeowner. If you are uncomfortable performing any of the listed tasks, please call your dealer for a service appointment.

More frequent cleaning may be required due to lint from carpeting or other factors. Control compartment, burner and circulating air passageway of the fireplace must be kept clean.

CAUTION! Risk of Burns! *The fireplace should be turned off and cooled before servicing.*

Glass Cleaning

Frequency: Seasonally

By: Homeowner

Tools Needed: Protective gloves, glass cleaner, drop cloth and a stable work surface.

CAUTION! Handle fixed glass assembly with care. *Glass is breakable.*

- Avoid striking, scratching or slamming glass
- Avoid abrasive cleaners
- **DO NOT** clean glass while it is hot
- Prepare a work area large enough to accommodate fixed glass assembly and door frame by placing a drop cloth on a flat, stable surface.

Note: Fixed glass assembly and gasketing may have residue that can stain carpeting or floor surfaces.

- Remove door or decorative front from fireplace and set aside on work surface.
- See Section 14.J for instructions to remove fixed glass assembly.
- Clean glass with a non-abrasive commercially available cleaner.
 - Light deposits: Use a soft cloth with soap and water
 - Heavy deposits: Use commercial fireplace glass cleaner (consult with your dealer)
- Carefully set fixed glass assembly in place on fireplace. Hold glass in place with one hand and secure glass latches with the other hand.
- Reinstall door or decorative front.

Doors, Surrounds, Fronts

Frequency: Annually

By: Homeowner

Tools needed: Protective gloves, stable work surface

- Assess condition of screen and replace as necessary.
- Inspect for scratches, dents or other damage and repair as necessary.
- Check that louvers are not blocked.
- Vacuum and dust surfaces.

Remote Control

Frequency: Seasonally

By: Homeowner

Tools needed: Replacement batteries and remote control instructions.

- Locate remote control transmitter and receiver.
- Verify operation of remote. Refer to remote control operation instructions for proper calibration and setup procedure.
- Place batteries as needed in remote transmitters and battery-powered receivers.
- Place remote control out of reach of children.

If not using your fireplace for an extended period of time (summer months, vacations/trips, etc), to prevent unintended operation:

- Remove batteries from remote controls.

Venting

Frequency: Seasonally

By: Homeowner

Tools needed: Protective gloves and safety glasses.

- Inspect venting and termination cap for blockage or obstruction such plants, bird nests, leaves, snow, debris, etc.
- Verify termination cap clearance to subsequent construction (building additions, decks, fences, or sheds). See Section 6.
- Inspect for corrosion or separation.
- Verify weather stripping, sealing and flashing remains intact.
- Inspect draft shield to verify it is not damaged or missing.

B. Maintenance Tasks-Qualified Service Technician

The following tasks must be performed by a qualified service technician.

Gasket Seal and Glass Assembly Inspection

Frequency: Annually

By: Qualified Service Technician

Tools needed: Protective gloves, drop cloth and a stable work surface.

- Inspect gasket seal and its condition.
- Inspect fixed glass assembly for scratches and nicks that can lead to breakage when exposed to heat.
- Confirm there is no damage to glass or glass frame. Replace as necessary.
- Verify that fixed glass assembly is properly retained and attachment components are intact and not damaged. Replace as necessary.

Logs

Frequency: Annually

By: Qualified Service Technician

Tools needed: Protective gloves.

- Inspect for damaged or missing logs. Replace as necessary. Refer to Section 14 for log placement instructions.
- Verify correct log placement and no flame impingement causing sooting. Correct as necessary.

Firebox

Frequency: Annually

By: Qualified Service Technician

Tools needed: Protective gloves, sandpaper, steel wool, cloths, mineral spirits, primer and touch-up paint.

- Inspect for paint condition, warped surfaces, corrosion or perforation. Sand and repaint as necessary.
- Replace fireplace if firebox has been perforated.

Control Compartment and Firebox Top

Frequency: Annually

By: Qualified Service Technician

Tools needed: Protective gloves, vacuum cleaner, dust cloths

- Vacuum and wipe out dust, cobwebs, debris or pet hair. Use caution when cleaning these areas. Screw tips that have penetrated the sheet metal are sharp and should be avoided.
- Remove all foreign objects.
- Verify unobstructed air circulation.

Burner Ignition and Operation

Frequency: Annually

By: Qualified Service Technician

Tools needed: Protective gloves, vacuum cleaner, whisk broom, flashlight, voltmeter, indexed drill bit set, and a manometer.

- Verify burner is properly secured and aligned with pilot or igniter.
- Clean off burner top, inspect for plugged ports, corrosion or deterioration. Replace burner if necessary.
- Replace Glowing embers with new dime-size pieces. **DO NOT** block ports or obstruct lighting paths. Refer to Section 14 for proper ember placement.
- Check for smooth lighting and ignition carryover to all ports. Verify that there is no ignition delay.
- Inspect for lifting or other flame problems.
- Verify air shutter setting is correct. See Section 14 for required air shutter setting. Verify air shutter is clear of dust and debris.
- Inspect orifice for soot, dirt and corrosion. Verify orifice size is correct. See Service Parts List for proper orifice sizing.
- Verify manifold and inlet pressures. Adjust regulator as required.
- Inspect pilot flame pattern and strength. See Figures 3.1 and 3.2 for proper pilot flame pattern. Clean or replace orifice spud as necessary.
- Inspect IPI flame-sensing rod for soot, corrosion and deterioration. Polish with fine steel wool or replace as required.
- Verify that there is not a short in flame sense circuit by checking continuity between pilot hood and flame sense rod. Replace pilot as necessary.

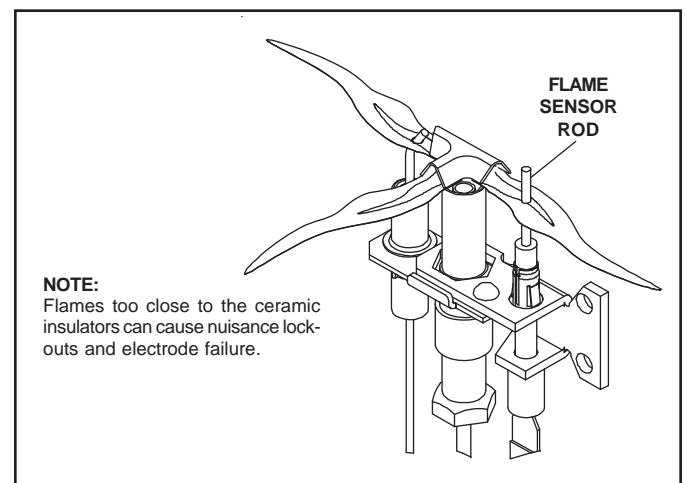

Figure 3.1 IPI Pilot Flame Pattern

4 Getting Started

Installer Guide

A. Typical Appliance System

NOTICE: Illustrations and photos reflect typical installations and are for design purposes only. Illustrations/diagrams are not drawn to scale. Actual product may vary from pictures in manual

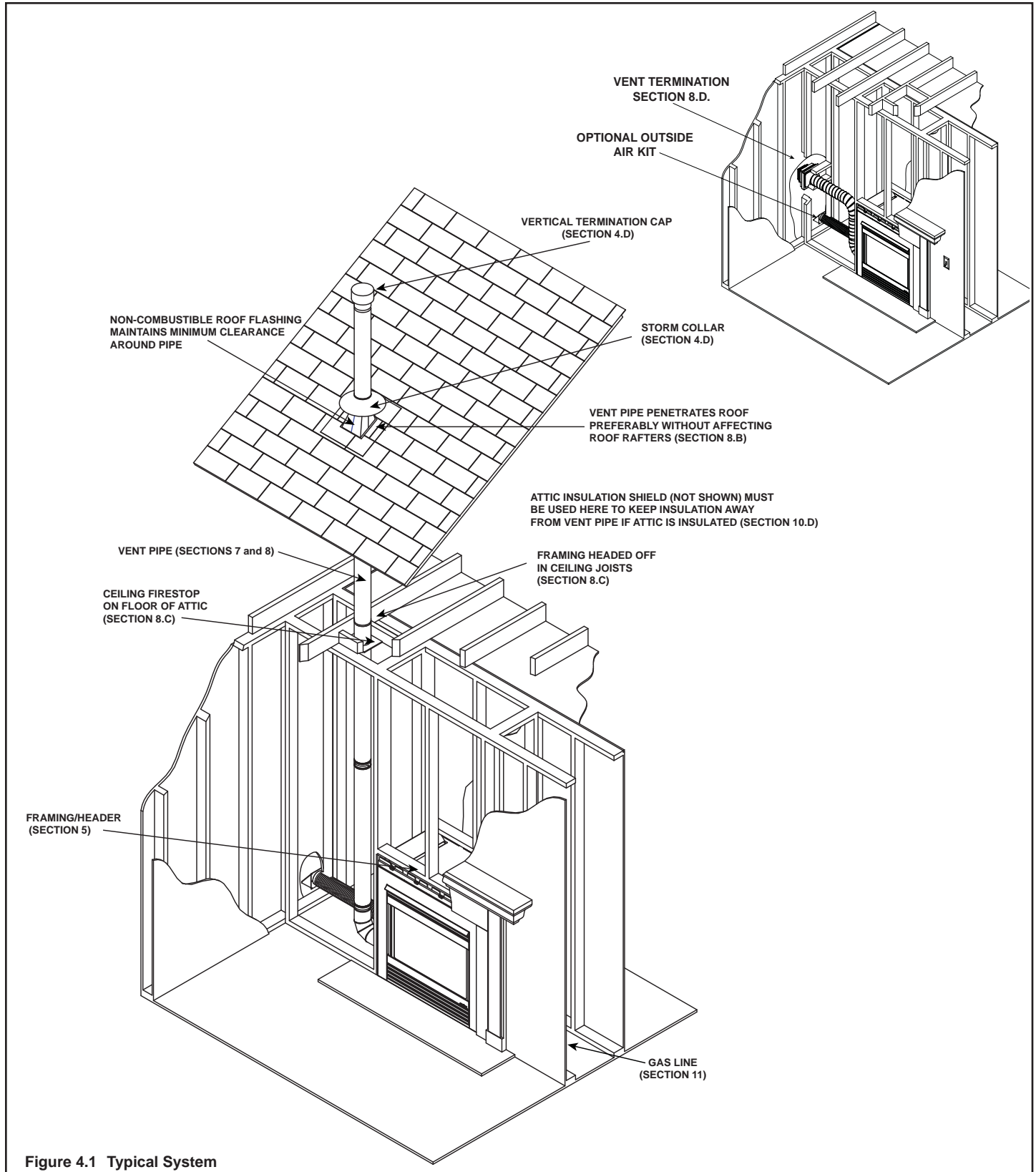

Figure 4.1 Typical System

B. Design and Installation Considerations

Heat & Glo B-type vent gas appliances are designed to operate with all exhaust gases expelled to the outside of the building, and combustion air pulled from the room.

Installation **MUST** comply with local, regional, state and national codes and regulations. Consult insurance carrier, local building inspector, fire officials or authorities having jurisdiction over restrictions, installation inspection and permits.

Before installing, determine the following:

- Where the appliance is to be installed.
- The vent system configuration to be used.
- Gas supply piping requirements.
- Electrical wiring requirements.
- Framing and finishing details.
- Whether optional accessories—devices such as a fan, wall switch, or remote control—are desired.

Improper installation, adjustment, alteration, service or maintenance can cause injury or property damage. For assistance or additional information, consult a qualified service technician, service agency or your dealer.

C. Tools and Supplies Needed

Before beginning the installation be sure that the following tools and building supplies are available.

Tape measure	Framing material
Pliers	Noncorrosive leak check solution
Hammer	Phillips screwdriver
Gloves	Framing square
Voltmeter	Electric drill and bits (1/4 in.)
Plumb line	Safety glasses
Level	Reciprocating saw
Manometer	Flat blade screwdriver
1/2 - 3/4 in. length, #6 or #8 Self-drilling screws	
Caulking material (300°F minimum continuous exposure rating)	
One 1/4 in. female connection (for optional fan).	

D. Inspect Appliance and Components

The following B-vent components are needed for installation.

- Fireplace Box
- Pipe Components
- Firestops
- Attic Insulation Shield
- Elbows
- Strapping
- Roof Flashing or Chase Top
- Termination Cap
- Storm Collar
- Carefully remove the appliance and components from the packaging.
- The vent system components and decorative doors and fronts may be shipped in separate packages.
- If packaged separately, the log set and appliance grate must be installed.
- Report to your dealer any parts damaged in shipment, particularly the condition of the glass.
- **Read all of the instructions before starting the installation. Follow these instructions carefully during the installation to ensure maximum safety and benefit.**

WARNING! Risk of Fire or Explosion! Damaged parts could impair safe operation. **DO NOT** install damaged, incomplete or substitute components. Keep appliance dry.

Hearth & Home Technologies disclaims any responsibility for, and the warranty will be voided by, the following actions:

- Installation and use of any damaged appliance or vent system component.
- Modification of the appliance or vent system.
- Installation other than as instructed by Hearth & Home Technologies.
- Improper positioning of the gas logs or the glass door.
- Installation and/or use of any component part not approved by Hearth & Home Technologies.

Any such action may cause a fire hazard.

WARNING! Risk of Fire, Explosion or Electric Shock! **DO NOT** use this appliance if any part has been under water. Call a qualified service technician to inspect the appliance and to replace any part of the control system and/or gas control which has been under water.

E. Negative Pressure

WARNING! Asphyxiation Risk! Negative pressure can cause spillage of combustion fumes and soot. Fireplace needs to draft properly for safety.

Draft is the pressure difference needed to vent fireplaces successfully. Considerations for successful draft include:

- Preventing negative pressure
- Location of fireplace and chimney

Negative pressure results from the imbalance of air available for the fireplace to operate properly. Causes for this imbalance include:

- Exhaust fans (kitchen, bath, etc.)
- Range hoods
- Combustion air requirements for furnaces, water heaters and other combustion appliances
- Clothes dryers
- Location of return-air to furnace or air conditioning
- Imbalances of the HVAC air handling system
- Upper level air leaks (recessed lighting, attic hatch opening, duct leaks)

To minimize the effects of negative air pressure, the following must be considered:

- Install the fresh air kit. Install the intake on the side of the house towards prevailing winds during the heating season.
- When horizontally terminating the exhaust, install fresh air intake in the same pressure zone as the exhaust pipe termination cap.

- Ensure adequate outdoor air is supplied for combustion appliances and exhaust equipment.
- Ensure furnace and air conditioning return vents are not located in the immediate vicinity of the fireplace.
- Avoid installing the fireplace near doors, walkways or small isolated spaces.
- Recessed lighting should be of “sealed can” design; attic hatches weather stripped or sealed; and attic mounted ductwork and air handler joints and seams taped or sealed.
- Basement installations should be avoided due to stack effect. Stack effect creates negative pressure in lower levels. Hearth & Home Technologies recommends the use of direct vent fireplaces in basements.

Location of the fireplace and chimney will affect performance. As shown in Figure 4.2, the chimney should:

- Be installed through the warm space enclosed by the building envelope. This helps to produce more draft, especially during lighting and die-down of the fire.
- Penetrate the highest part of the roof. This minimizes the effects of wind turbulence.
- Be located away from trees, adjacent structures, uneven roof lines and other obstructions.

Offsets can restrict draft so their use should be minimized. Consider the fireplace location relative to floor and ceiling and attic joists.

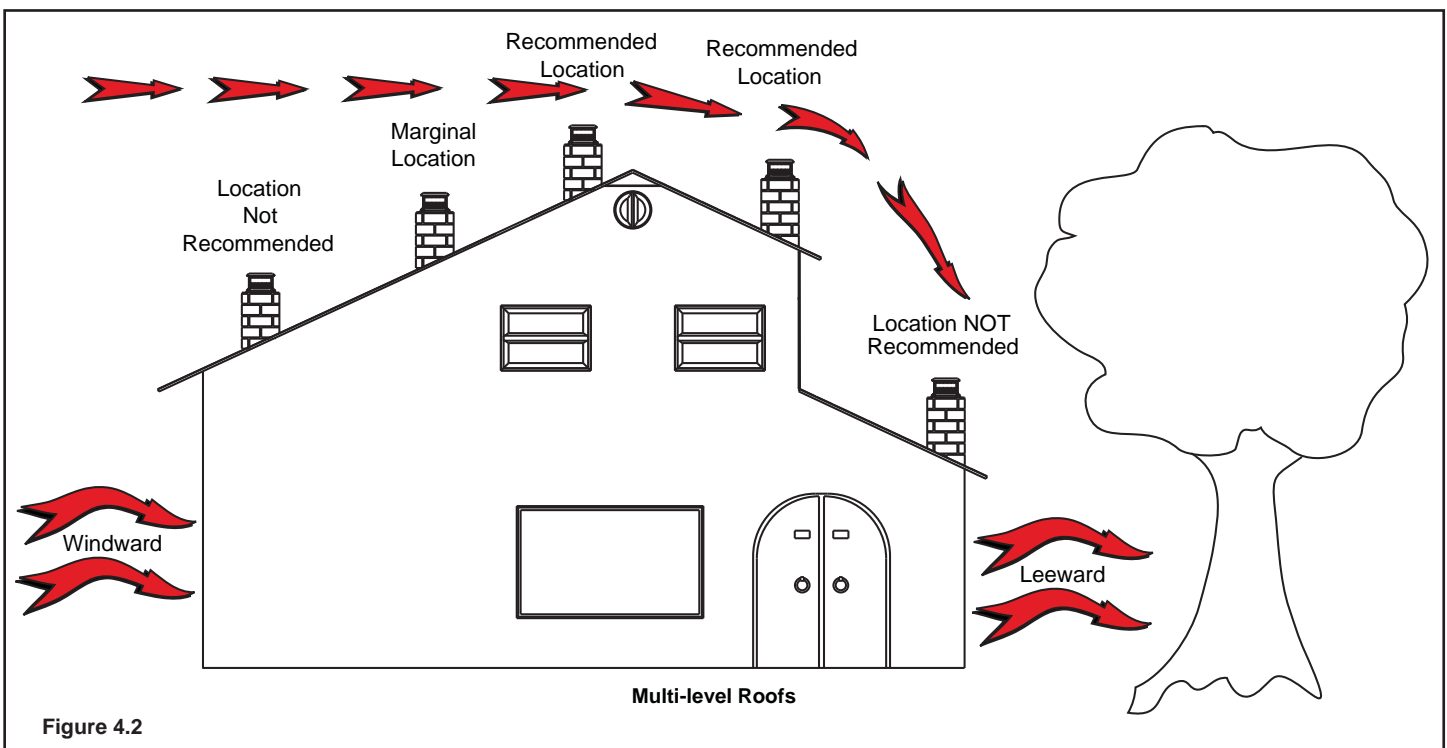

Figure 4.2

5 Framing and Clearances

A. Selecting Appliance Location

When selecting a location for the appliance it is important to consider the required clearances to walls (see Figure 5.1).

WARNING! Risk of Fire or Burns! Provide adequate clearance around air openings and for service access. **Due to high temperatures, the appliance should be located out of traffic and away from furniture and draperies.**

NOTICE: Illustrations reflect typical installations and are FOR DESIGN PURPOSES ONLY. Illustrations/diagrams are not drawn to scale. Actual installation may vary due to individual design preference.

NOTICE: This See-Through appliance is NOT designed or approved for an indoor/outdoor application.

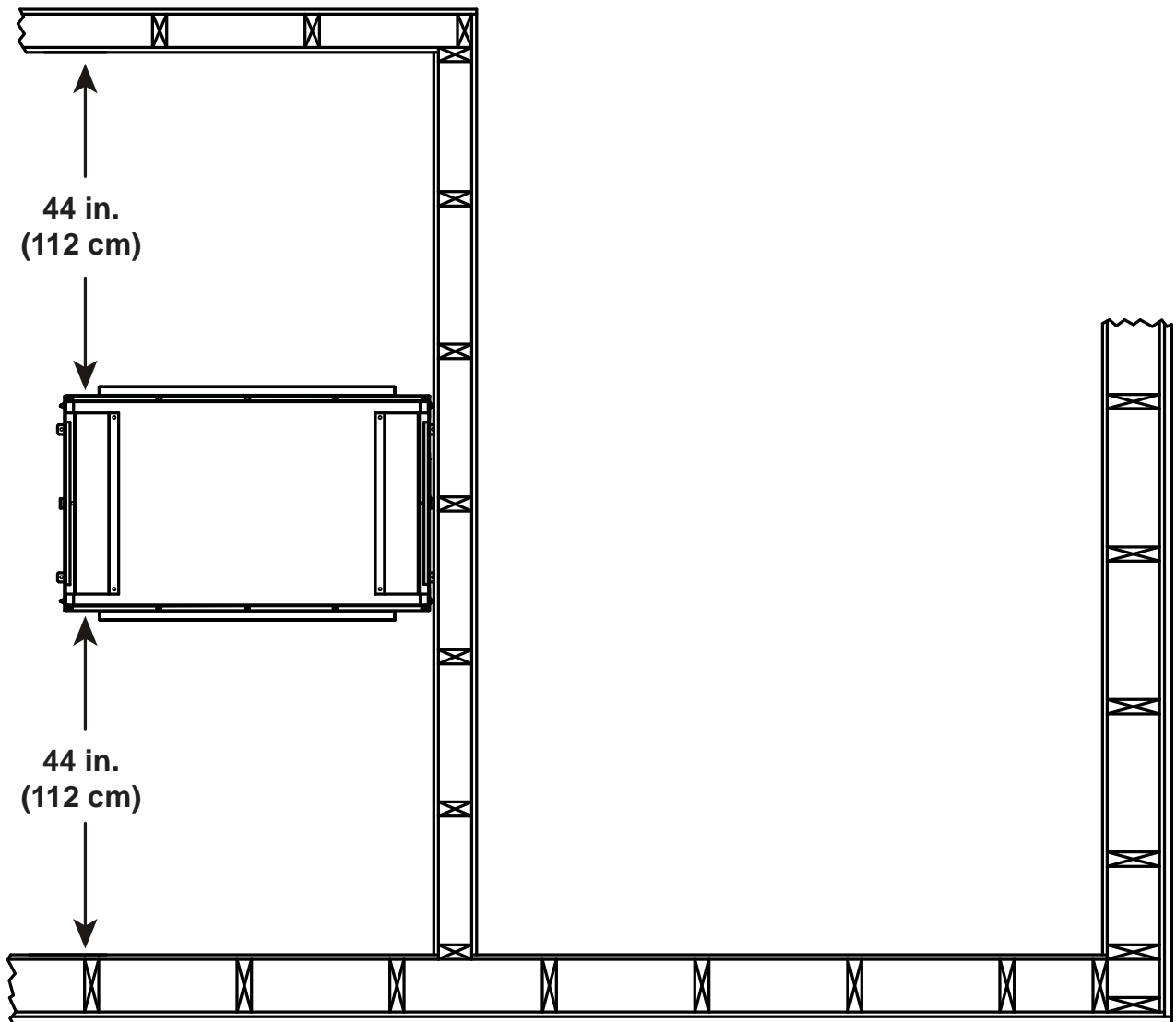

Figure 5.1 Appliance Locations

B. Constructing the Appliance Chase

A chase is a vertical box-like structure built to enclose the gas appliance and/or its vent system. In cooler climates the vent should be enclosed inside the chase.

NOTICE: Treatment of ceiling firestops and wall shield firestops and construction of the chase may vary with the type of building. These instructions are not substitutes for the requirements of local building codes. Therefore, you **MUST** check local building codes to determine the requirements to these steps.

Chases should be constructed in the manner of all outside walls of the home to prevent cold air drafting problems. The chase should not break the outside building envelope in any manner.

Walls, ceiling, base plate and cantilever floor of the chase should be insulated. Vapor and air infiltration barriers should be installed in the chase as per regional codes for the rest of the home. Additionally, in regions where cold air infiltration may be an issue, the inside surfaces may be sheetrocked and taped for maximum air tightness.

To further prevent drafts, the wall shield and ceiling firestops should be caulked with caulk with a minimum of 300° continuous exposure rating to seal gaps. Gas line holes and other openings should be caulked with caulk

with a minimum of 300° continuous exposure rating or stuffed with unfaced insulation. If the appliance is being installed on a cement surface, a layer of plywood may be placed underneath to prevent conducting cold up into the room.

C. Clearances

NOTICE: Install appliance on hard metal or wood surfaces extending full width and depth. **DO NOT** install directly on carpeting, vinyl, tile or any combustible material other than wood.

WARNING! Risk of Fire! Maintain specified air space clearances to appliance and vent pipe:

- Insulation and other materials must be secured to prevent accidental contact.
- The chase must be properly blocked to prevent blown insulation or other combustibles from entering and making contact with fireplace or chimney.
- Failure to maintain airspace may cause overheating and a fire.

The top, back and sides of the fireplace are defined by standoffs. The minimum clearance to a perpendicular wall extending past the face of the fireplace is one inch (25mm). The metal ends of the fireplace may NOT be recessed into combustible construction.

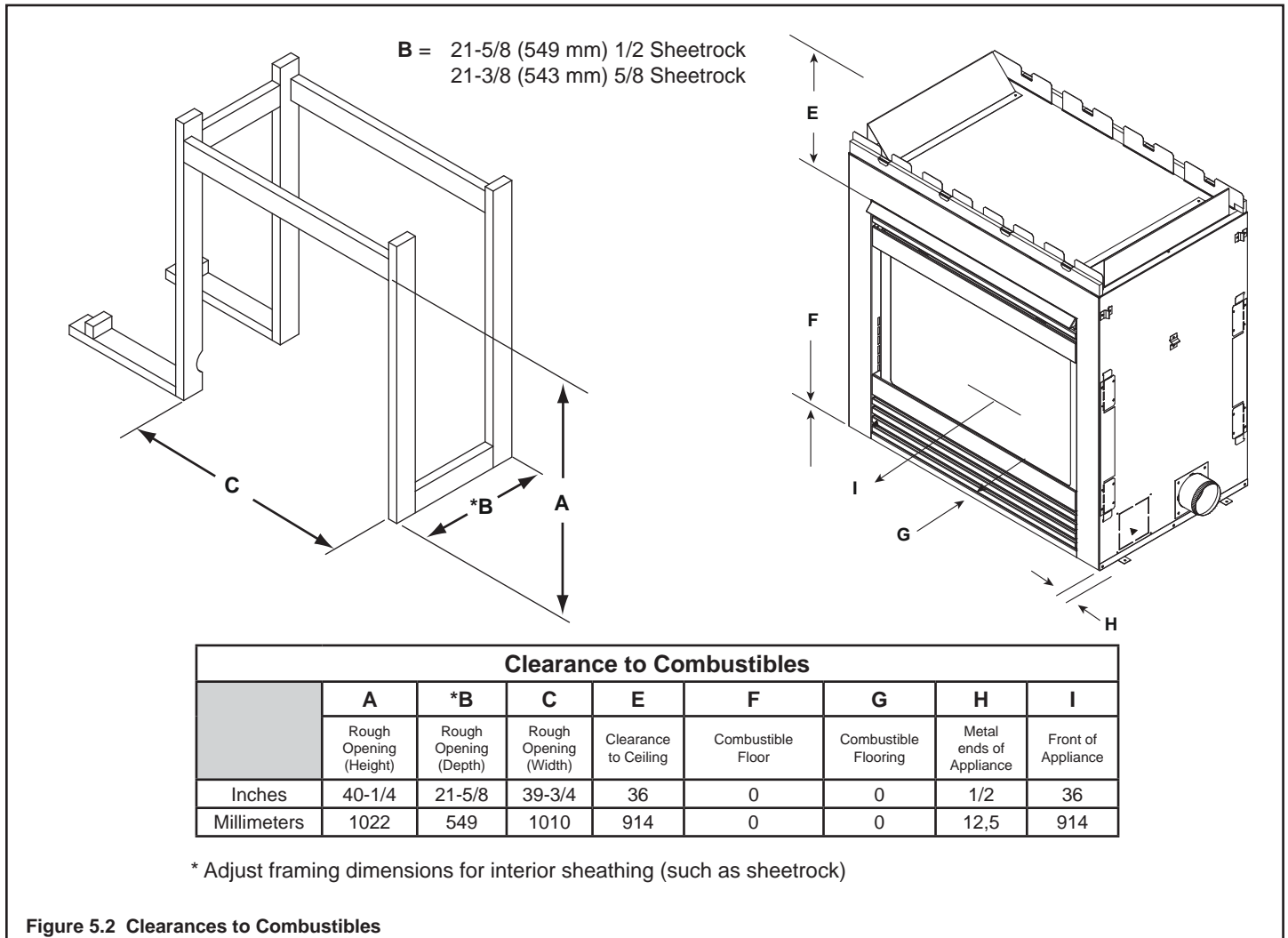
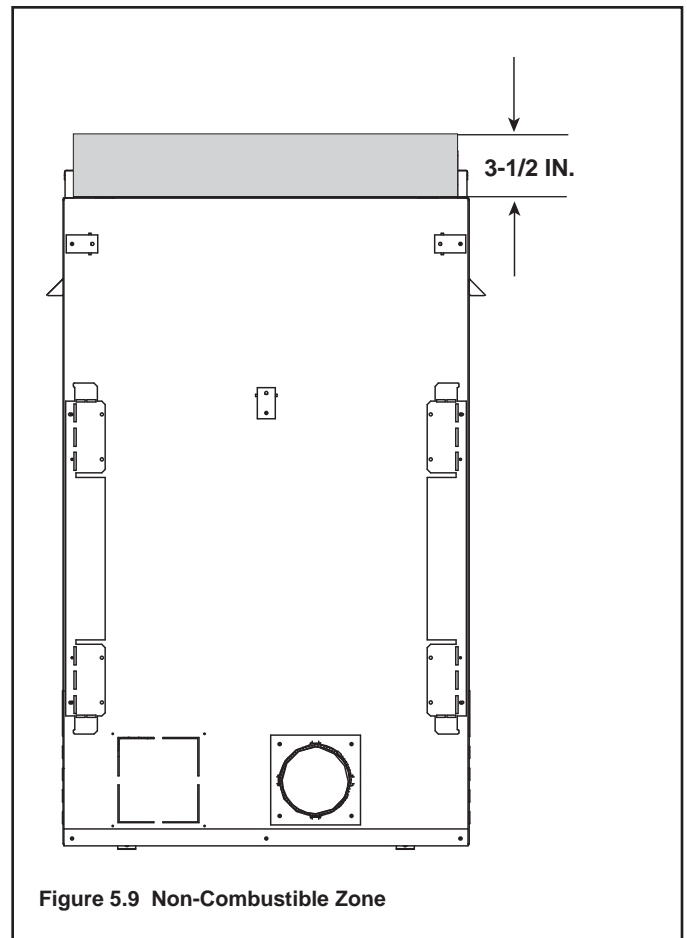
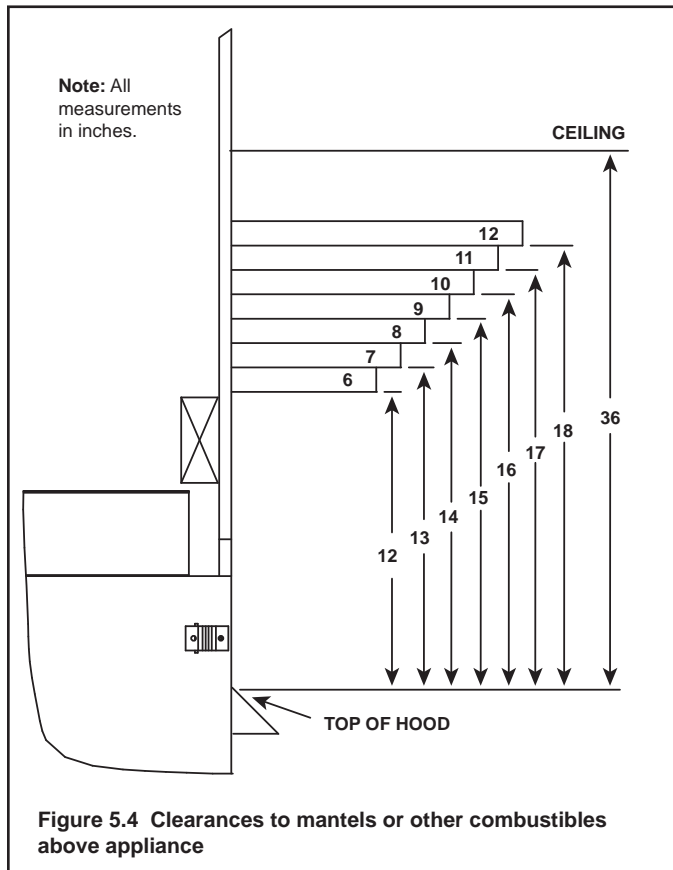

Figure 5.2 Clearances to Combustibles

D. Mantel and Wall Projections

WARNING! Risk of Fire! Comply with all minimum clearances as specified. Framing or finishing material closer than the minimums listed must be constructed entirely of noncombustible materials (i.e., steel studs, concrete board, etc).

Combustible Mantels



6 Termination Locations

A. Vent Termination Minimum Clearances

 **WARNING**



Fire Risk.

Maintain vent clearance to combustibles as specified.

- **DO NOT** pack air space with insulation or other materials.

Failure to keep insulation or other materials away from vent pipe may cause overheating and fire.

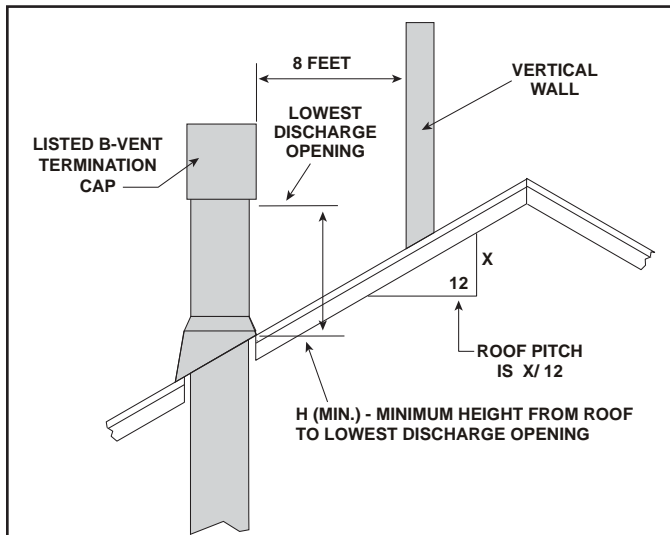

Roof Pitch	H (Min.) Ft.
Flat to 6/12.....	1.0*
Over 6/12 to 7/12.....	1.25*
Over 7/12 to 8/12.....	1.5*
Over 8/12 to 9/12.....	2.0*
Over 9/12 to 10/12.....	2.5
Over 10/12 to 11/12.....	3.25
Over 11/12 to 12/12.....	4.0
Over 12/12 to 14/12.....	5.0
Over 14/12 to 16/12.....	6.0
Over 16/12 to 18/12.....	7.0
Over 18/12 to 20/12.....	7.5
Over 20/12 to 21/12.....	8.0

* 3 foot minimum in snow regions

Figure 6.1 Minimum Height From Roof To Lowest Discharge Opening

A	B
6 in. (minimum) up to 20 in. 152 mm/508 mm	18 in. minimum 457 mm
20 in. and over	0 in. minimum

* If using decorative cap cover(s), this distance may need to be increased. Refer to the installation instructions supplied with the decorative cap cover.

** In a staggered installation with both gas and wood or fuel oil terminations, the wood or fuel oil termination cap must be higher than the gas termination cap.

Figure 6.2 Staggered Termination Caps

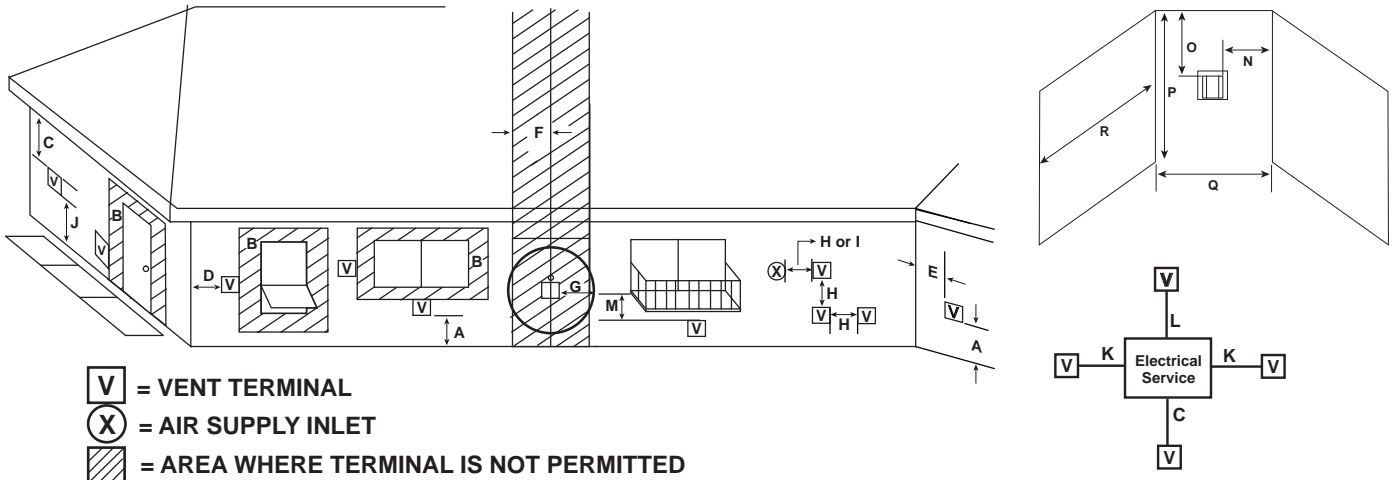

V = VENT TERMINAL
X = AIR SUPPLY INLET
 [Hatched] = AREA WHERE TERMINAL IS NOT PERMITTED

- A = 12 inches.....clearances above grade, veranda, porch, deck or balcony
- B = 12 inches.....clearance to window or door that may be opened, or to permanently closed window.
- C = 24 inches.....clearance below unventilated soffit
 24 inches.....clearance below ventilated soffit
 60 inches.....clearance below vinyl soffits and electrical service
- D = 6 inches.....clearance to outside corner
- E = 6 inches.....clearance to inside corner
- F = 3 ft. (Canada).....not to be installed above a gas meter/regulator assembly within 3 feet horizontally from the center-line of the regulator
- G = 3 ft.....clearance to gas service regulator vent outlet
- H = 12 inches.....clearance to non-mechanical (unpowered) air supply inlet, combustion air inlet or direct-vent termination
- i = 3 ft. (U.S.A.)
 6 ft. (Canada).....clearance to a mechanical (powered) air supply inlet

All mechanical air intakes within 10 feet of a termination cap must be a minimum of 3 feet below termination.

J = 7 ft. On **public** property: clearance above paved sidewalk or a paved driveway.

A vent shall not terminate directly above a sidewalk or paved driveway which is located between two single family dwellings and serves both dwellings.

K = 6 inches.....clearance from sides of electrical service
 L = 12 inches.....clearance above electrical service
 Location of the vent termination must not interfere with access to the electrical service.

M = 18 inches clearance under veranda, porch, deck, balcony or overhang
 42 inchesvinyl or composite overhang
 Permitted when veranda, porch, deck or balcony is fully open on a minimum of 2 sides beneath the floor.

Covered Alcove Applications
 (Spaces open only on one side and with an overhang)

- N = 6 inches non-vinyl sidewalls
 12 inches vinyl sidewalls
- O = 18 inches non-vinyl soffit and overhang
 42 inches vinyl soffit and overhang
- P = 8 ft.

	Q_{MIN}	R_{MAX}
1 cap	3 feet	$2 \times Q_{ACTUAL}$
2 caps	6 feet	$1 \times Q_{ACTUAL}$
3 caps	9 feet	$2/3 \times Q_{ACTUAL}$
4 caps	12 feet	$1/2 \times Q_{ACTUAL}$

$Q_{MIN} = \# \text{ termination caps} \times 3$ $R_{MAX} = (2 / \# \text{ termination caps}) \times Q_{ACTUAL}$

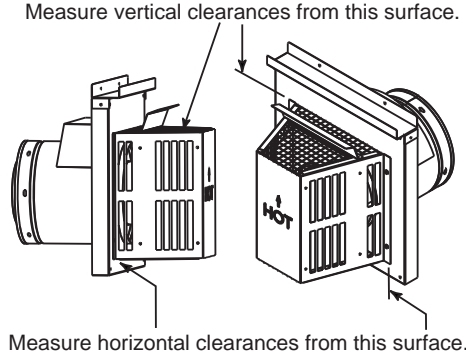

CAUTION! Risk of Burns! Termination caps are **HOT**. Consider proximity to doors, traffic areas or where people may pass or gather (sidewalk, deck, patio, etc.). Listed cap shields available. Contact your dealer.

- Local codes or regulations may require different clearances.
- Vent system termination is **NOT** permitted in screened porches.
- Vent system termination is permitted in porch areas with two or more sides open.
- Hearth & Home Technologies assumes no responsibility for the improper performance of the appliance when the venting system does not meet these requirements.
- Vinyl protection kits are suggested for use with vinyl siding.

Figure 6.3 Minimum Clearances for Termination

7 Vent Information and Diagrams

A. Vent Guidelines

WARNING! Fire Risk/Asphyxiation! This appliance requires the specified pipe for operation. Incorrect pipe may cause spillage, condensation and overheating.

- Follow pipe manufacturer's installation guidelines when installing the appliance.

Model GATEWAY is approved to use DuraVent 4-inch (102 mm) diameter B-type vent for installations that terminate vertically. The PV-Flex Series vent pipe is approved for use in installations that terminate horizontally. This pipe is tested and listed as an approved component of the fireplace.

This model may also use single wall rigid or flexible gas vent **IF** and **ONLY IF** the vent system is installed within non-combustible construction such as a masonry chimney. The same diameter noted above for B-type vent must be used for single-wall vent (see Figure 5.1).

For B-type vent the clearance to combustibles is 1-inch all around the pipe. Follow vent manufacturers **REQUIRED** clearances. For PV-Flex the clearances are 1-1/2 in. top and 1 in. sides and bottom when venting horizontally and 1 in. on all sides when passing vertically through combustible materials.

NOTE: Due to the positive pressure within the Gateway venting system, when using PV-FLEX use a 1/2 in. bead of HIGH TEMPERATURE silicone caulk on ALL pipe ends and connectors throughout the vent run to ensure a completely sealed system.

Vent pipes must be installed within the conditioned house envelope in order to avoid flue gas condensation. Vertical termination through an unconditioned attic space is permissible.

The flame and ember appearance may vary based on the type of fuel burned and the venting configuration used.

WARNING! Fire Risk/Explosion/Asphyxiation! DO NOT connect this gas appliance to a chimney flue serving a separate solid-fuel or gas burning appliance.

- Vent this appliance directly outside.
- Use separate vent system for this appliance.

May impair safe operation of this appliance or other appliances connected to the flue.

WARNING! Risk of Fire or Explosion! Insulation and other combustibles must not infringe on clearances.

- ALWAYS maintain specified clearances around venting and firestop systems.
- Install firestops as specified.

Failure to keep insulation or other material away from vent pipe may cause fire.

B. Vent System Configuration

CAUTION! Risk of Fire! ALL vent configuration specifications **MUST** be followed. This product is tested and listed to these specifications. Appliance performance will suffer if specifications are not followed.

Consult Local Building Code Officials and Codes for proper vent system installations.

Plan and install the vent system using the parameters shown in this vent system configuration chart.

No. of 90° Elbows/ Bends	Maximum Vertical Run	Maximum Horizontal Run	Maximum Total Run
0	-	40' (12.2 m)	40' (12.2 m)
1	50' (15.2 m)	-	50' (15.2 m)
1	-	35' (10.7 m)	35' (10.7 m)
2	-	35' (10.7 m)	35' (10.7 m)
2	35' (10.7 m)	35' (10.7 m)	38' (11.6 m)
3	30' (9.1 m)	35' (10.7 m)	35' (10.7 m)
4	25' (7.6 m)	32' (9.8 m)	35' (10.7 m)
5	25' (7.6m)	30' (9.1 m)	33' (10.1 m)

Maximum Total Run: = 50 FT.

Maximum No. Of Elbows/bends: five - 90° or ten - 45°

The following figures are examples of approved venting conditions. Venting downward (3 feet maximum) is approved, to allow venting below the floor. However, only one downward section is allowed for up to, but not exceeding 3 feet maximum.

Note: It is always better to first attach a straight section of vent to the unit before attaching an elbow. Avoid using elbows in the vent system if possible.

Continue to add vent components, until the vent run is completed.

See Section 8 for instructions regarding assembly of vent sections and securing vent sections.

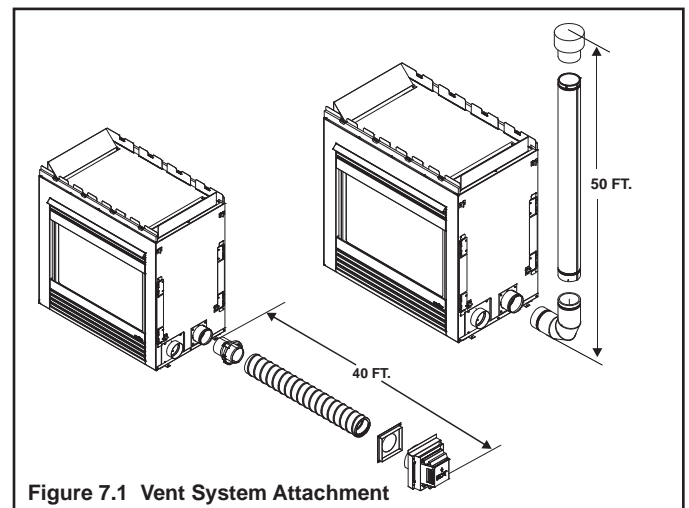

Figure 7.1 Vent System Attachment

⚠ WARNING



Fire Risk. Explosion Risk.

Do NOT pack insulation or other combustibles between ceiling firestops.

- ALWAYS maintain specified clearances around venting and firestop systems.
- Install wall shield and ceiling firestops as specified.

Failure to keep insulation or other material away from vent pipe may cause fire.



VENTING WITH ONE 90° ELBOW
V (FT.)
50 Ft. Max. (13.8 m)

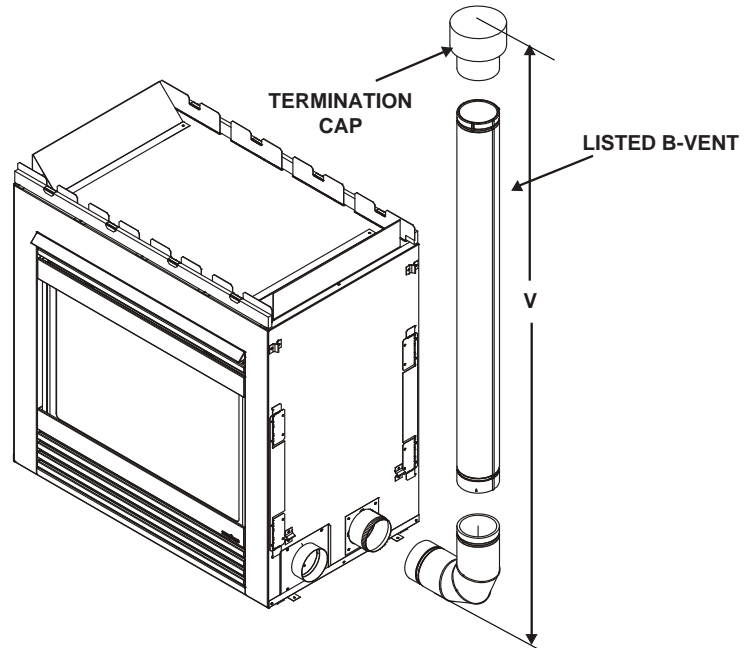

Figure 7.2 B-Type venting only

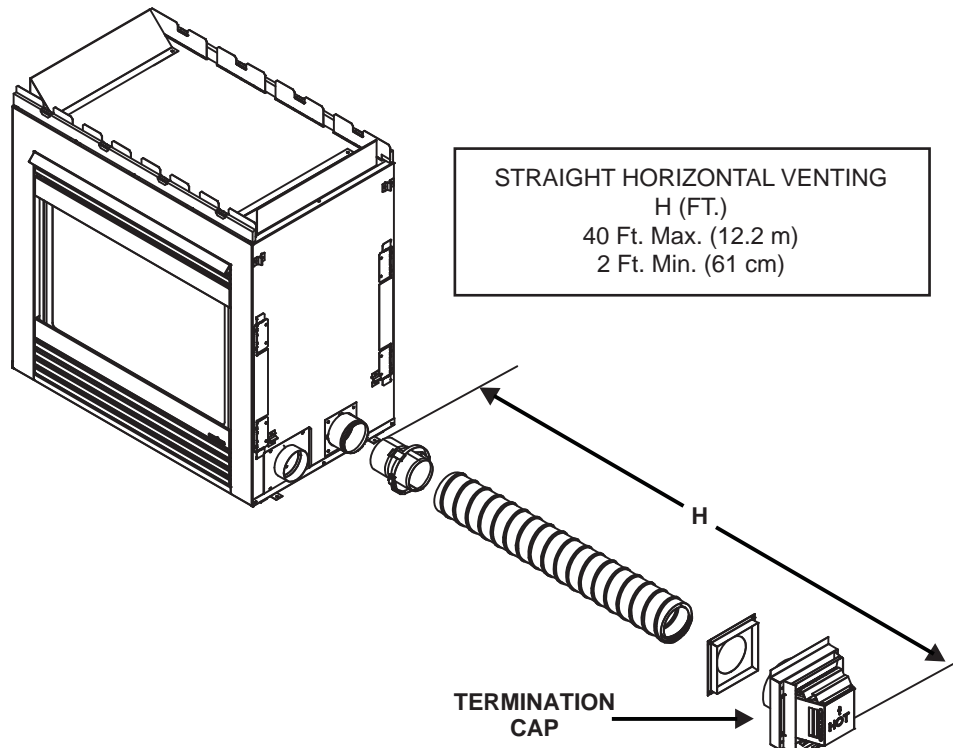
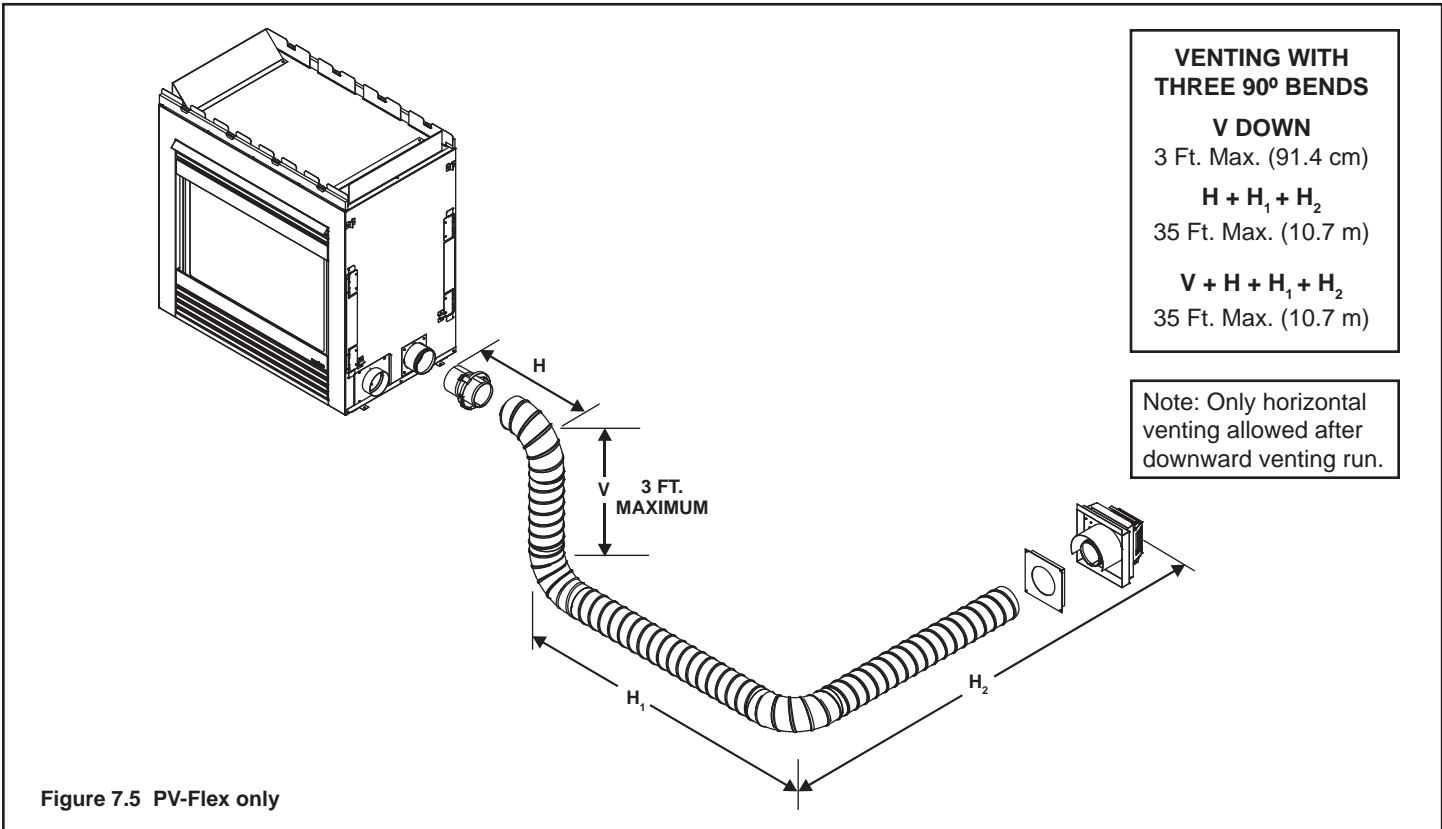
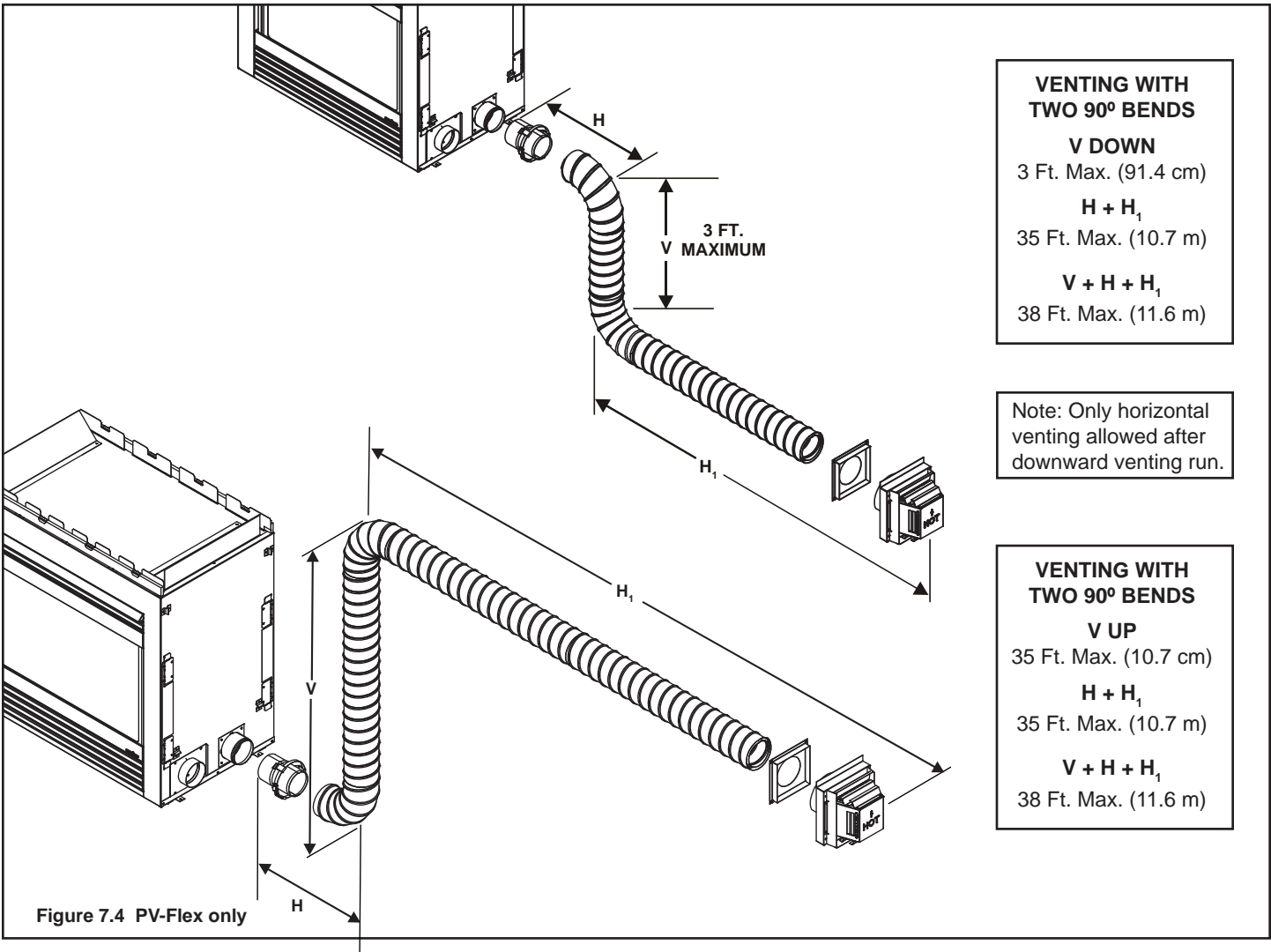
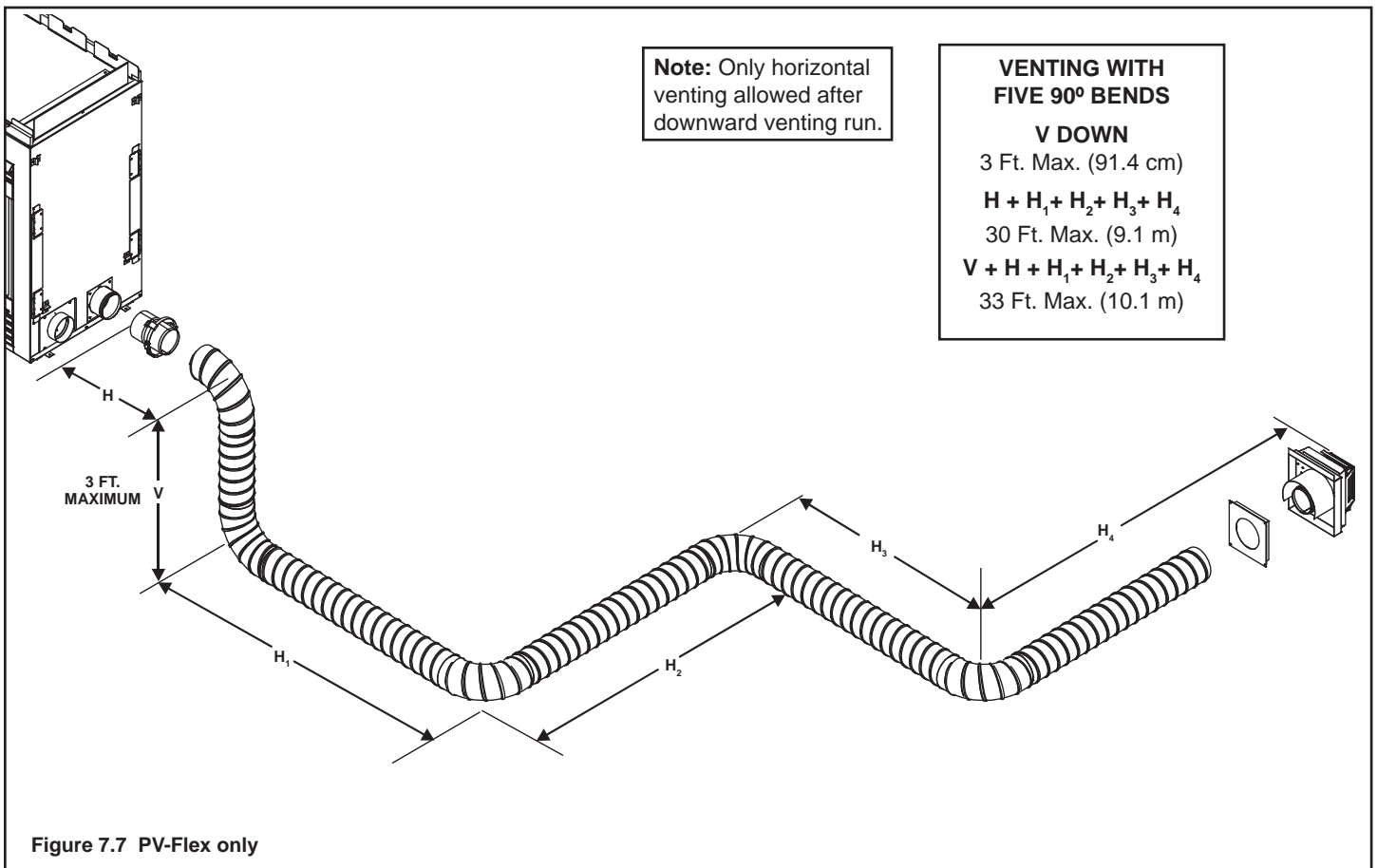
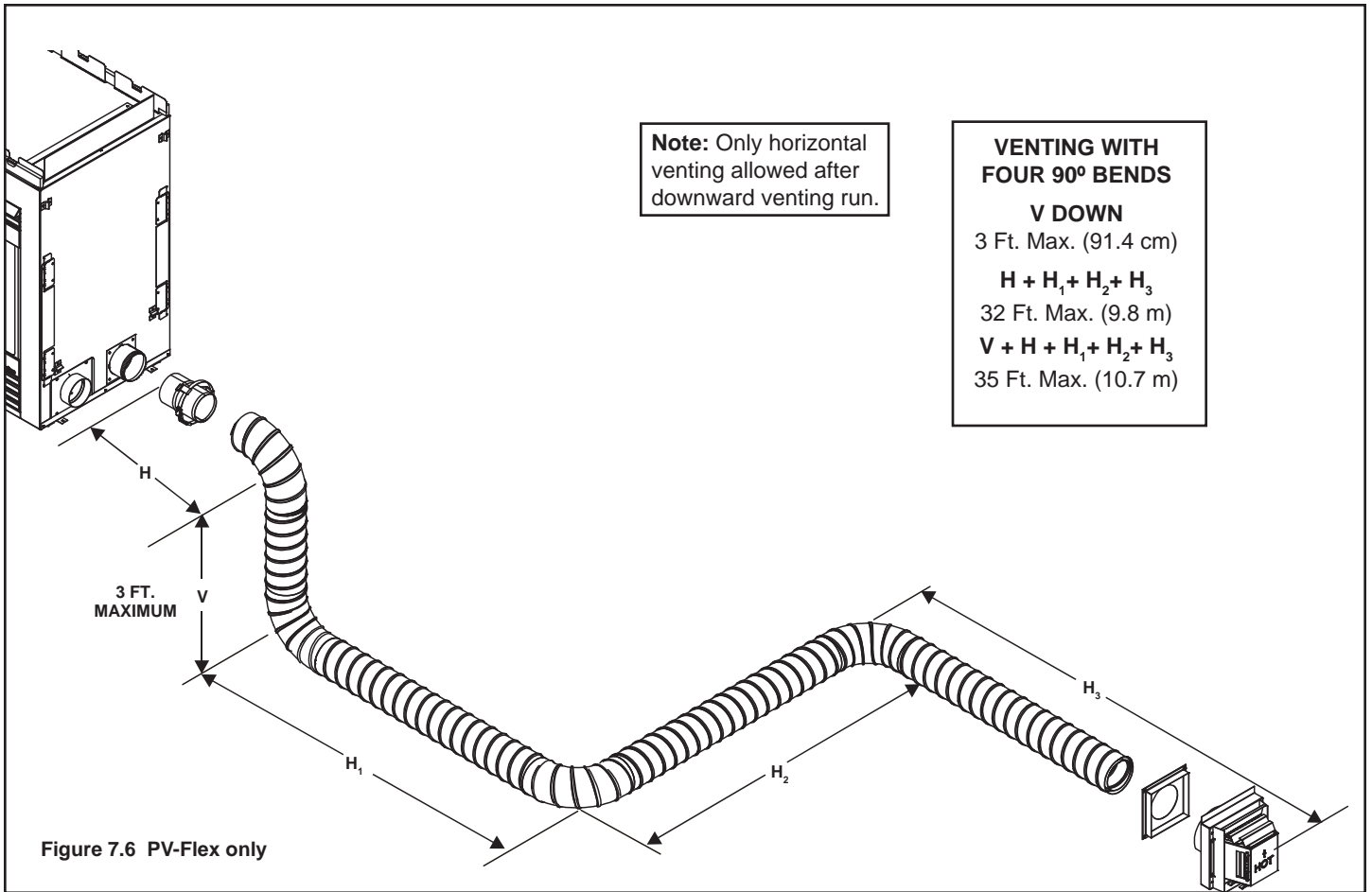

Figure 7.3 PV-Flex venting only.





8 Vent Clearances and Framing

A. Pipe Clearances to Combustibles

Vent clearances are per vent manufacturer's specifications. MUST be Listed B-Vent pipe.

WARNING! Risk of Fire! Maintain air space clearance to vent. **DO NOT** pack insulation or other combustibles:

- Between ceiling firestops
- Between wall shield firestops
- Around vent system

Failure to keep insulation or other material away from vent pipe may cause over heating and fire.

B. Install Support Brackets

For Horizontal Runs - The PV-Flex vent system must be supported at least every 5 feet to assure proper clearances to combustibles is maintained.

To install support brackets for horizontal runs:

- Place the pipe supports around the vent pipe.
- Nail the pipe supports to the framing members.

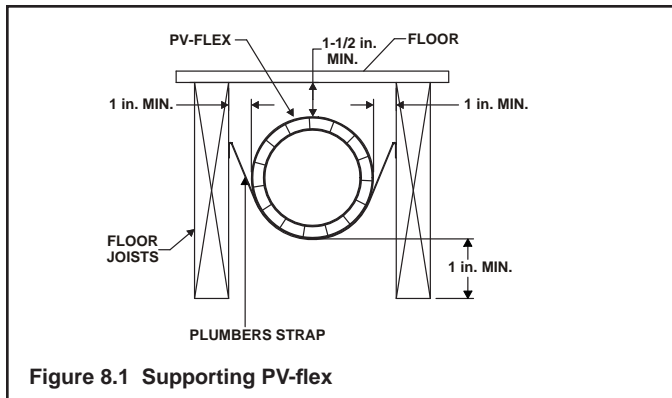

Figure 8.1 Supporting PV-flex

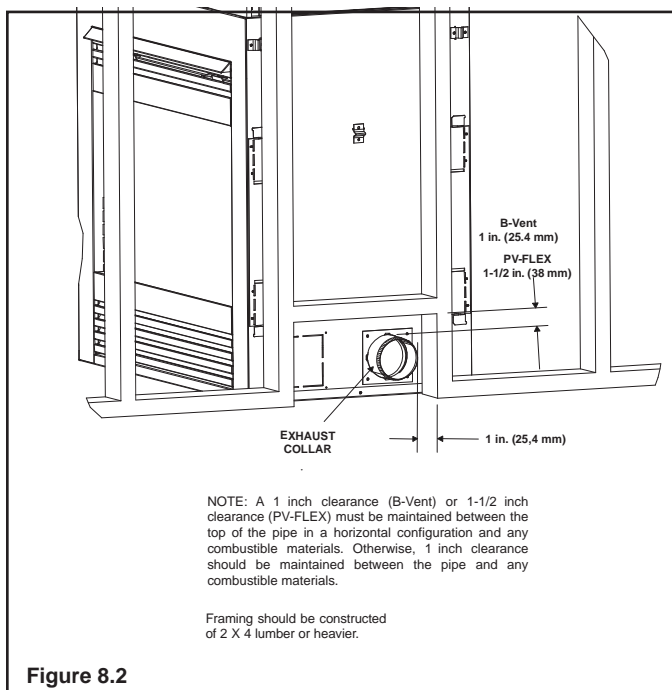

Figure 8.2

Minimum Clearances from the Vent Pipe to Combustible Materials

	B-Vent Inches (mm)	PV-Flex Inches (mm)
Vertical Sections	1 (25)	1 (25)
Horizontal Sections		
Top.....	1 (25)	1-1/2 (38)
Bottom.....	1 (25)	1 (25)
Sides.....	1 (25)	1 (25)
At Wall Firestops		
Top.....	1 (25)	1-1/2 (38)
Bottom.....	1 (25)	1 (25)
Sides.....	1 (25)	1 (25)

For Vertical Runs - The vent system (B-Vent and PV-Flex) must be supported every eight 8 feet to maintain clearances to combustibles 1 inch on all sides.

To install support brackets for vertical runs:

- Attach wall brackets to the vent pipe and secure the wall bracket to the framing members with nails or screws.

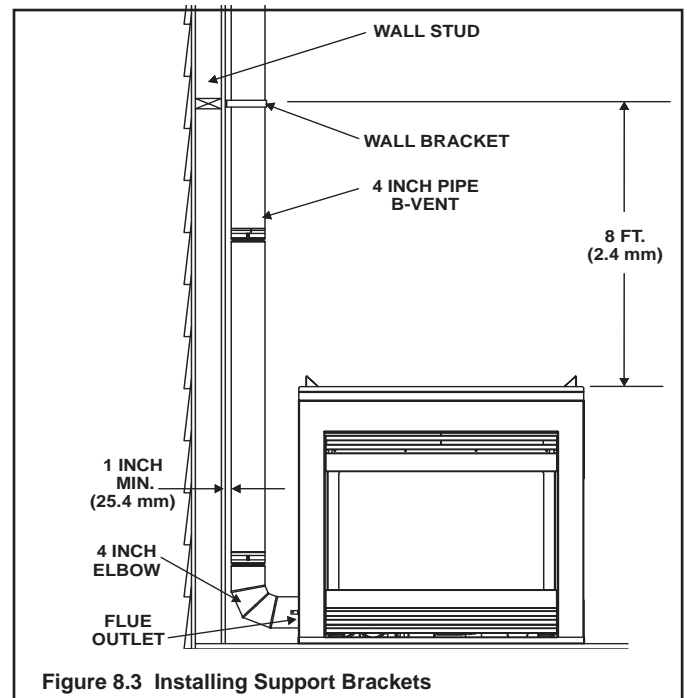

Figure 8.3 Installing Support Brackets



WARNING

Fire Hazard

Keep loose materials or blown insulation from touching the vent pipe.

- National building codes recommend using attic shield to keep loose materials/ blown insulation from contacting vent.
- Hearth & Home Technologies requires the use of an attic shield.

C. Install Wall Shield Firestops

For Horizontal Runs - Wall shield firestops are **REQUIRED** on both sides of a combustible wall through which the vent passes.

To install wall shield firestops for horizontal runs that pass through either interior or exterior walls:

- Cut a 7 in. x 8 in. (178 mm x 204 mm) hole through the wall.
- Position the wall shield firestops on both sides of the hole previously cut and secure the wall shield firestops with nails or screws.
- Continue the vent run through the wall shield firestops.

Note: There must be no insulation or other combustibles inside the framed wall shield firestop opening.

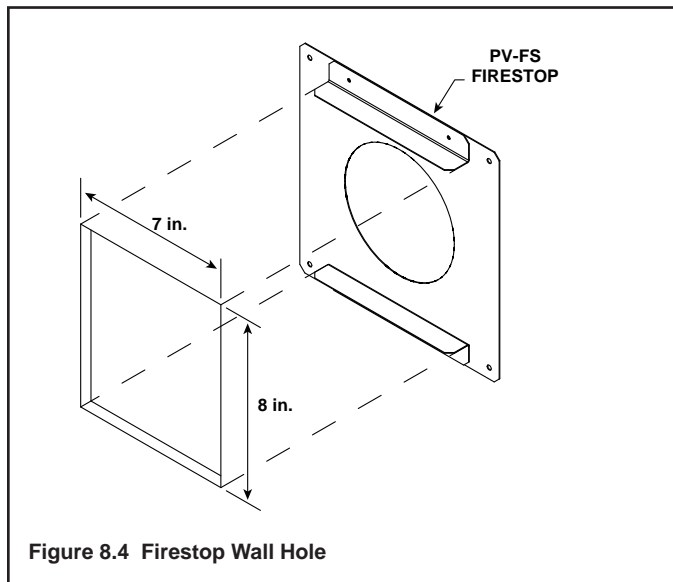

Figure 8.4 Firestop Wall Hole

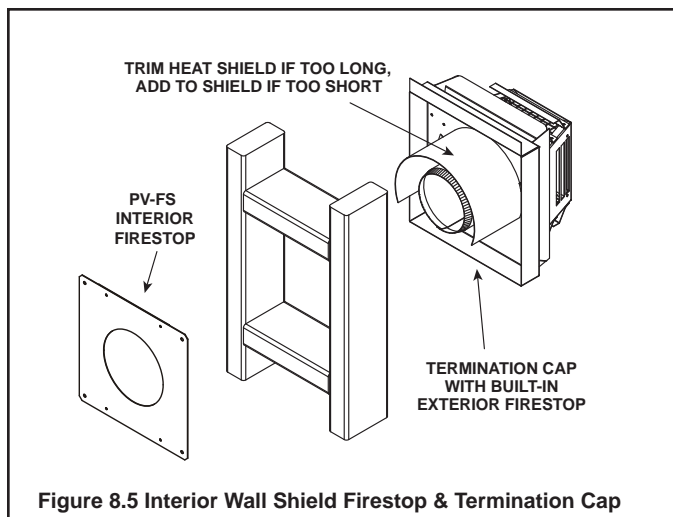

Figure 8.5 Interior Wall Shield Firestop & Termination Cap

For Vertical Runs - One ceiling firestop is **REQUIRED** at the hole in each ceiling through which the vent passes.

To install firestops for vertical runs that pass through ceilings:

- Position a plumb bob directly over the center of the vertical vent component.

- Mark the ceiling to establish the center point of the vent.
- Drill a hole or drive a nail through this center point.
- Check the floor above for any obstructions, such as wiring or plumbing runs.
- Reposition the fireplace and vent system, if necessary, to accommodate the ceiling joists and/or obstructions.
- Cut a 7 in. x 8 in. (178 mm x 204 mm) hole through the ceiling, using the center point previously marked.
- Frame the hole with framing lumber the same size as the ceiling joists.

Note: There must be NO INSULATION or other combustibles inside the framed firestop opening.

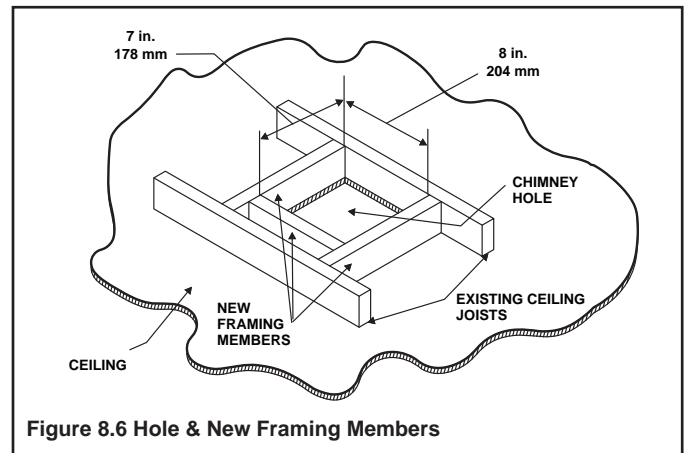

Figure 8.6 Hole & New Framing Members

If the area above the ceiling is **NOT** an attic, position and secure the ceiling firestop on the ceiling side of the previously cut and framed hole.

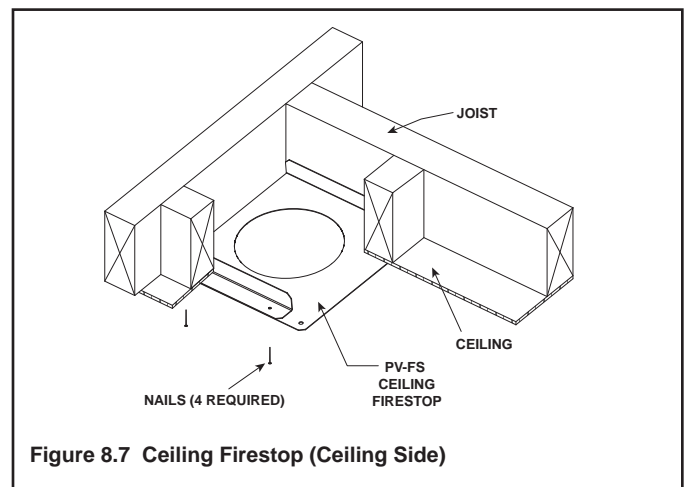

Figure 8.7 Ceiling Firestop (Ceiling Side)

If the area above the ceiling **IS** an attic, position and secure the firestop on top of the previously framed hole. Figure 8.7 shows an attic installation. Keep insulation away from the vent pipe at least 1 inch (25 mm).

While it is not mandatory, it is strongly recommended that an attic insulation shield be used whenever insulation can come in contact with the vent pipe. Follow your local building codes.

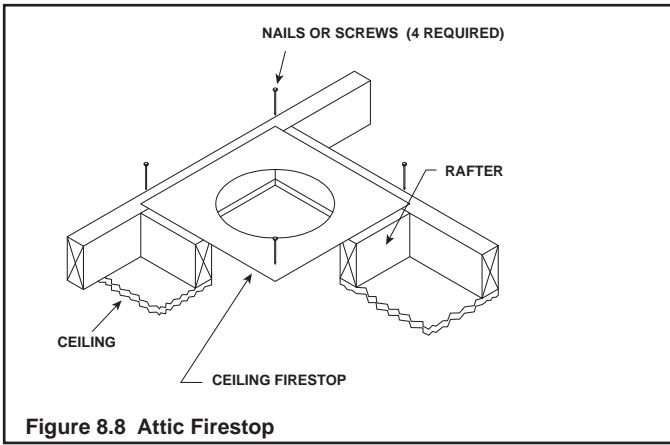

Figure 8.8 Attic Firestop

Note: For vertical termination the termination cap must be listed for the vent pipe used.

D. Vent Termination

Note: Due to the positive pressure within the Gateway venting system, when using PV-FLEX use a 1/2 inch bead of silicone caulk on ALL pipe ends and connectors throughout the vent run to ensure a completely sealed system.

For Horizontal Terminations - To attach and secure the termination cap to the last section of horizontal vent:

- Venting from the fireplace must extend through the interior firestop to flush with exterior surface.
- The termination kit should pass through the wall firestops from the exterior of the building.
- Adjust the termination cap to its final exterior position on the building.
- Figure 16.2 shows the approved cap and pipe for horizontal termination. No other components may be used.
- For vent runs over 25 feet in length, a pipe connector must be used to connect one pipe section to another (see Figure 10.2).

For Vertical Terminations - To locate the vent and install the vent sections:

- Locate and mark the vent center point on the underside of the roof, and drive a nail through the center point.
- Make the outline of the roof hole around the center point nail.
- The size of the roof hole framing dimensions depend on the pitch of the roof. There MUST BE a 1 inch (25.4 mm) clearance from the vertical vent pipe to combustible materials.
- Mark the roof hole accordingly.
- Cover the opening of the installed vent pipes.
- Cut and frame the roof hole.
- Use framing lumber the same size as the roof rafters and install the frame securely. Flashing anchored to the frame must withstand heavy winds.

- Continue to install concentric vent sections up through the roof hole (for inside vent installations) or up past the roof line until you reach the appropriate distance above the roof (for outside terminations).

WARNING: major U.S. Building codes specify minimum chimney and/or vent height above the roof top. These minimum heights are necessary in the interest of safety. See the following diagram for minimum heights, provided the termination cap is at least two feet from a vertical wall and two feet below a horizontal overhang.

Note: This also pertains to vertical vent systems installed on the outside of the building.

To seal the roof hole, and to divert rain and snow from the vent system:

- Attach a flashing to the roof using nails, and use a non-hardening mastic around the edges of the flashing base where it meets the roof.
- Attach a storm collar over the flashing joint to form a water-tight seal. Place non-hardening mastic around the joint, between the storm collar and the vertical pipe.
- Slide the termination cap over the end of the vent pipe and rotate the pipe clockwise 1/4 turn.

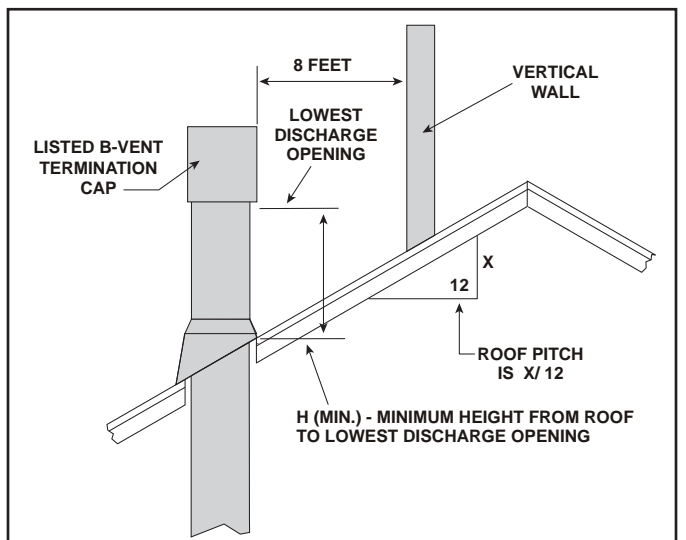

Roof Pitch	H (Min.) Ft.
Flat to 6/12.....	1.0*
Over 6/12 to 7/12.....	1.25*
Over 7/12 to 8/12.....	1.5*
Over 8/12 to 9/12.....	2.0*
Over 9/12 to 10/12.....	2.5
Over 10/12 to 11/12.....	3.25
Over 11/12 to 12/12.....	4.0
Over 12/12 to 14/12.....	5.0
Over 14/12 to 16/12.....	6.0
Over 16/12 to 18/12.....	7.0
Over 18/12 to 20/12.....	7.5
Over 20/12 to 21/12.....	8.0

* 3 foot minimum in snow regions

Figure 8.9 Minimum Height From Roof To Lowest Discharge Opening

9 Appliance Preparation

A. Installing Outside Air Kit Damper Assembly (Optional)

CAUTION! Risk of Cuts/Abrasions/Flying Debris. Wear protective gloves and safety glasses during installation. Sheet metal edges are sharp.

WARNING! Risk of Fire/Asphyxiation. DO NOT draw outside combustion air from:

- Wall, floor or ceiling cavity.
- Enclosed space such as an attic or garage.
- Close proximity to exhaust vents or chimneys.

Fumes or odor may result.

This unit is equipped to accept outside air. **It is recommended that an AK-TV air kit be used with this appliance.** By using outside make-up air, the amount of room air used for combustion will be reduced. However, in a negative pressure condition the outside air kit **MUST** be installed to obtain proper performance and to help prevent spillage of combustion gases.

A 4-inch side collar/damper (found in AK-TV Kit) must be installed on the fireplace by attaching the side collar to the outer wrap of the fireplace at the right-hand rear corner using sheetmetal screws. Attach damper handle (extended handle found in manual bag) to the damper door prior to attaching door to outer wrap. Then lift the handle into the notch under the fireplace. See Figure 7.2. Attach one end of a 4-inch flexible air duct (not provided in the AK-TV Kit) to the side collar and the other end of the duct to the make-up air termination cap. Use plastic tie straps to secure the ends of the flex duct to each collar.

WARNING: when terminating the venting horizontally the make-up air termination must be at a lower elevation than the exhaust termination.

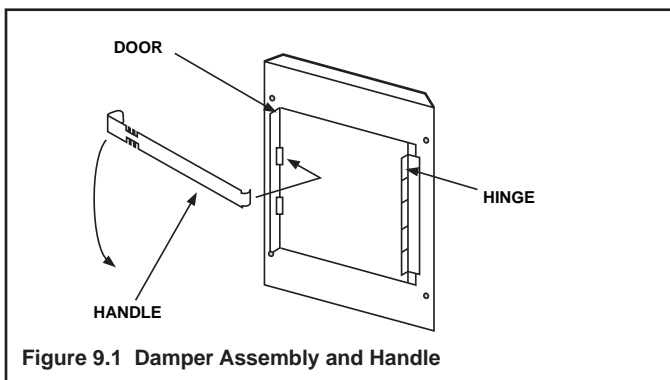

- Attach damper assembly to appliance using screws provided (see Figure 9.2).
- Insert narrow end of handle through tab and into upper slot of door.
- Check handle operation. Pull handle out to open, and in to close.

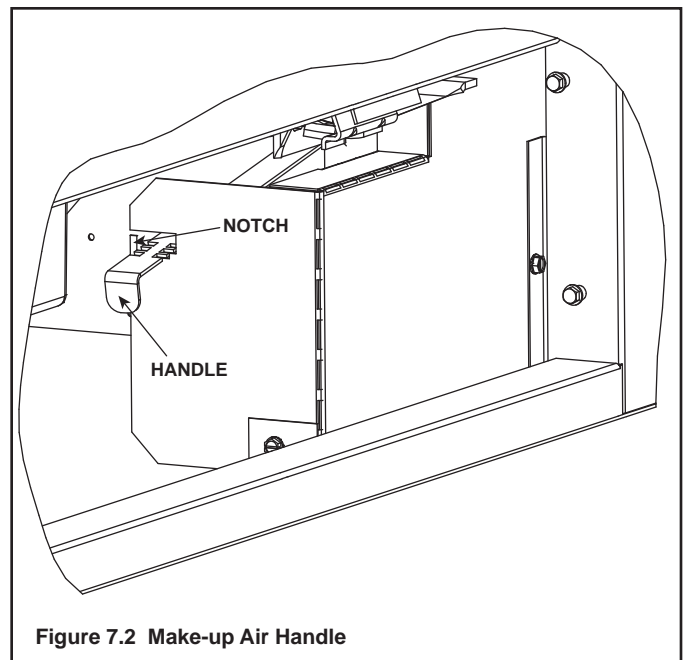
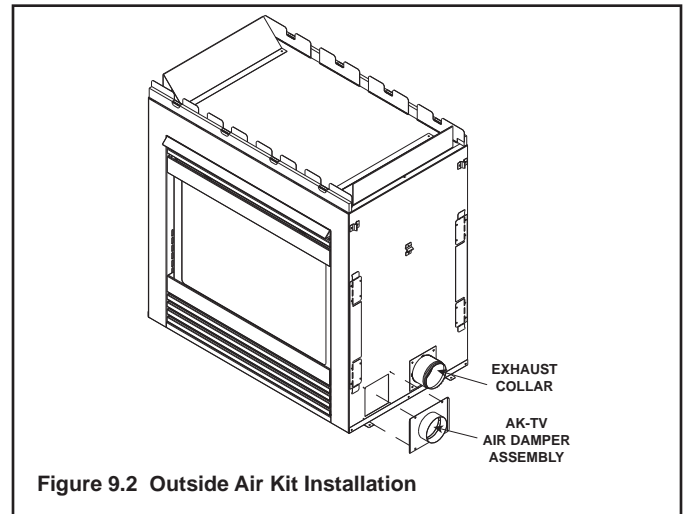

Note: Pull handle to open damper. Push handle to close damper.

B. Gas and Electrical Connections

If applicable, ensure that gas and electrical connections are installed at this time. Refer to Section 11 (Gas Information) and Section 12 (Electrical Information).

C. Securing and Leveling the Appliance

WARNING! Risk of Fire! Prevent contact with:

- Sagging or loose insulation
- Insulation backing or plastic
- Framing and other combustible materials

Block openings into the chase to prevent entry of blown-in insulation. Make sure insulation and other materials are secured.

DO NOT notch the framing around the appliance standoffs.

Failure to maintain air space clearance may cause overheating and fire.

The diagram shows how to properly position, level, and secure the appliance. See Figure 9.4. Nailing tabs are provided to secure the appliance to the framing members.

- Bend out nailing tabs on each side.
- Place the appliance into position.
- Keep nailing tabs flush with the framing.
- Level the appliance from side to side and front to back.
- Shim the appliance as necessary. It is acceptable to use wood shims underneath the appliance.
- Secure the appliance to the framing by using nails or screws through the nailing tabs.
- Secure the appliance to the floor by inserting two screws through the pilot holes at the bottom of the appliance.

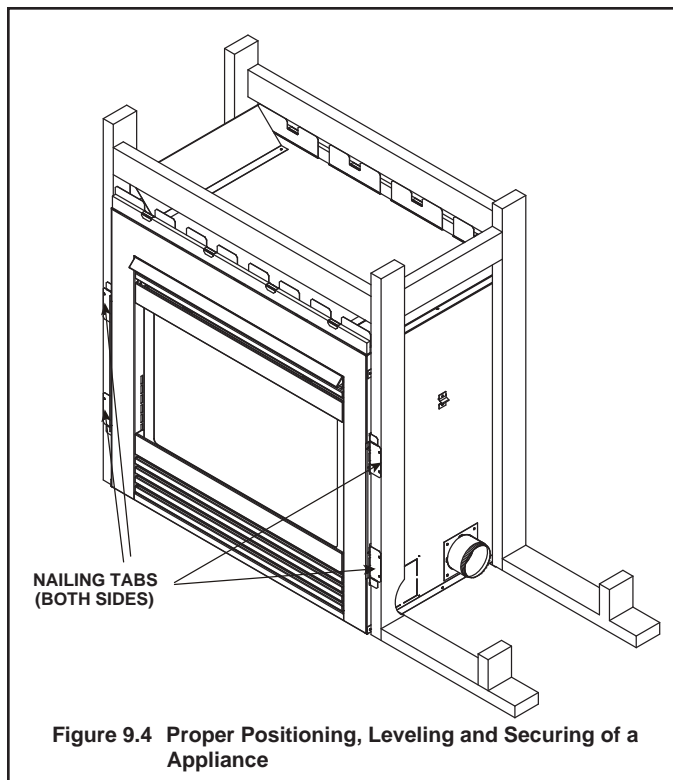

10 Installing Vent Pipe

A. Assembly of Vent Sections

This appliance requires PV-Flex venting for any run that terminates horizontally. Four (4) in. Duravent B-type vent is approved for vertical termination.

⚠ WARNING



Fire Risk
Exhaust Fumes Risk
Impaired Performance of Appliance

- Assemble pipe sections per B-vent manufacturer's instructions.
- Use support tabs for screws.
- Screws must not exceed one inch long and must not penetrate inner lining.
- Pipe may separate if not properly joined.



C. Securing Vent Sections (B-Type Vent)

Follow B-Vent manufacturer's instructions to secure B-vent pieces together properly.

⚠ WARNING



Fire Risk.
Explosion Risk.
Combustion Fume Risk.

Use vent run supports per vent manufacturer's installation instructions.



Connect vent sections per vent manufacturer's installation instructions.

- Maintain all clearances to combustibles.
- Maintain specified slope (if required).

Improper support may allow vent to sag or separate.

B. Attaching Vent to Firebox

B-Type venting: Follow vent pipe manufacturer's instructions.

PV-FLEX venting: Use starter collar included with the PV-FLEX10 and PV-FLEX20.

- Seal the PVFLEX-CONNECT to the PV-flex pipe sections by applying a 1/2 inch bead of high temperature silicone around the inside edge of the PV-FLEX pipe and then secure with six 1/2 inch self-tapping screws. See Figure 8.2.

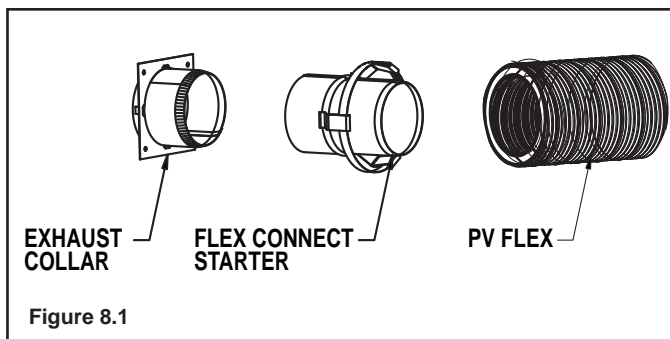

D. Securing Vent Sections (PV-FLEX)

- Secure Flex Connect Starter Section to the exhaust collar of the appliance with three 1/2 inch self-tapping screws.
- For vent runs that require multiple sections of PV-FLEX, a PVFLEX-CONNECT flex connector must be installed at each point where sections of PV-FLEX are connected.

Note: Due to the positive pressure within the Gateway venting system, when using PV-FLEX use a 1/2 inch bead of silicone caulk on ALL pipe ends and connectors throughout the vent run to ensure a completely sealed system.

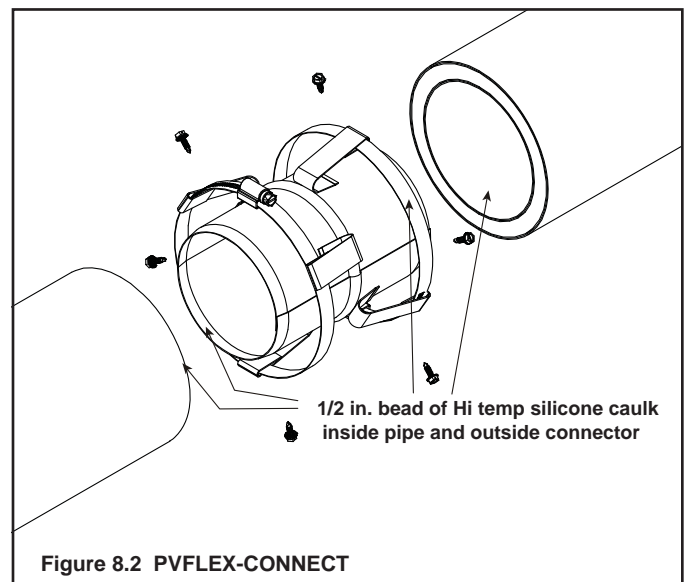

11 Gas Information

A. Fuel Conversion

- Make sure the appliance is compatible with available gas types.
- Conversions must be made by a qualified service technician using Hearth & Home Technologies specified and approved parts.

B. Gas Pressure

- Optimum appliance performance requires proper input pressures.
- Gas line sizing requirements will be determined in ANSI Z223.1 National Fuel Gas Code in the USA and CAN/CGA B149 in Canada.
- Pressure requirements are:

Gas Pressure	Natural Gas	Propane
Minimum inlet pressure	5.0 in. w.c.	11.0 in. w.c.
Maximum inlet pressure	14.0 in. w.c.	14.0 in. w.c.
Manifold pressure	3.5 in. w.c.	10.0 in. w.c.

WARNING! Risk of Fire or Explosion! High pressure will damage valve. Low pressure may cause explosion.

- Verify inlet pressures. Verify minimum pressures when other household gas appliances are operating.
- Install regulator upstream of valve if line pressure is greater than 1/2 psig.

⚠ WARNING	
	<p>Fire Risk. Explosion Hazard. High pressure will damage valve.</p> <ul style="list-style-type: none">• Disconnect gas supply piping BEFORE pressure testing gas line at test pressures above 1/2 psig.• Close the manual shutoff valve BEFORE pressure testing gas line at test pressures equal to or less than 1/2 psig.

Note: Have the gas supply line installed in accordance with local codes, if any. If not, follow ANSI 223.1. Installation should be done by a qualified installer approved and/or licensed as required by the locality. (In the Commonwealth of Massachusetts installation must be performed by a licensed plumber or gas fitter).

Note: A listed (and Commonwealth of Massachusetts approved) 1/2 in. (13 mm) T-handle manual shut-off valve and flexible gas connector are connected to the 1/2 in. (13 mm) control valve inlet.

- **If substituting for these components, please consult local codes for compliance.**

C. Gas Connection

- Refer to Reference Section 16 for location of gas line access in appliance.
- Gas line may be run through knockout(s) provided.
- The gap between supply piping and gas access hole may be caulked with high temperature caulk or stuffed with non-combustible, unfaced insulation to prevent cold air infiltration.
- Ensure that gas line does not come in contact with outer wrap of the appliance. Follow local codes.
- Pipe incoming gas line into valve compartment.
- Connect incoming gas line to the 1/2 in. (13 mm) connection on manual shutoff valve.

WARNING! Risk of Fire or Explosion! Support control when attaching pipe to prevent bending gas line.

- A small amount of air will be in the gas supply lines.

WARNING! Risk of Fire or Explosion! Gas build-up during line purge could ignite.

- Purge should be performed by qualified service technician.
- Ensure adequate ventilation.
- Ensure there are no ignition sources such as sparks or open flames.

Light the appliance. It will take a short time for air to purge from lines. When purging is complete the appliance will light and operate normally.

WARNING! Risk of Fire, Explosion or Asphyxiation! Check all fittings and connections with a non-corrosive commercially available leak-check solution. **DO NOT** use open flame. Fittings and connections could have loosened during shipping and handling.

WARNING! Risk of Fire! DO NOT change valve settings. This valve has been preset at the factory.

D. High Altitude Installations

NOTICE: If the heating value of the gas has been reduced, these rules do not apply. Check with your local gas utility or authorities having jurisdiction.

When installing above 2000 feet elevation:

- In the USA: Reduce burner orifice 4% for each 1000 feet above 2000 feet.
- In CANADA: Reduce burner orifice 10% for elevations between 2000 feet and 4500 feet. Above 4500 feet, consult local gas utility.

12 Electrical Information

A. Wiring Requirements

NOTICE: This appliance must be electrically wired and grounded in accordance with local codes or, in the absence of local codes, with **National Electric Code ANSI/NFPA 70-latest edition** or the **Canadian Electric Code CSA C22.1**.

- The gas control system used with this model is Intermittent Pilot Ignition (IPI). This system includes a 3V control valve, electronic module, and intermittent pilot.
- Wire the appliance junction box to 110-120 VAC. This is required for proper operation of the appliance.
- A 110-120 VAC circuit for this product must be protected with ground-fault circuit-interrupter protection, in compliance with the applicable electrical codes, when it is installed in locations such as in bathrooms or near sinks.
- • Low voltage and 110-120 VAC voltage cannot be shared within the same wall box.

WARNING! Risk of Shock or Explosion! DO NOT wire 110V to the valve or to the control module.

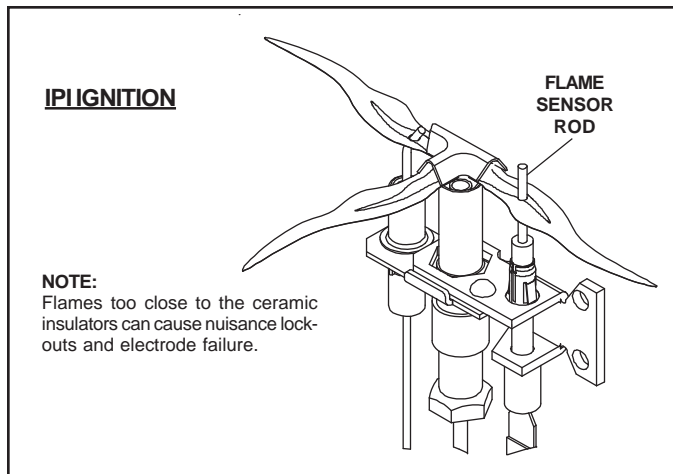

Figure 12.1 IPI Ignition

B. IntelliFire Ignition System Wiring

- Wire the appliance junction box to 110-120 VAC for proper operation of the appliance.

WARNING! Risk of Shock or Explosion! DO NOT wire IPI controlled appliance junction box to a switched circuit. Incorrect wiring will override IPI safety lockout.

- Refer to Figure 12.2, IntelliFire Pilot Ignition (IPI) Wiring Diagram.
- This appliance is equipped with an IntelliFire control valve which operates on a 3 volt system.
- Plug the 3-volt AC transformer into the appliance junction box to supply power to the unit.

C. Optional Accessories Requirements

- This appliance may be used with a wall switch or a remote control.

Wiring for optional Hearth & Home Technologies approved accessories should be done now to avoid reconstruction. Follow instructions that come with those accessories.

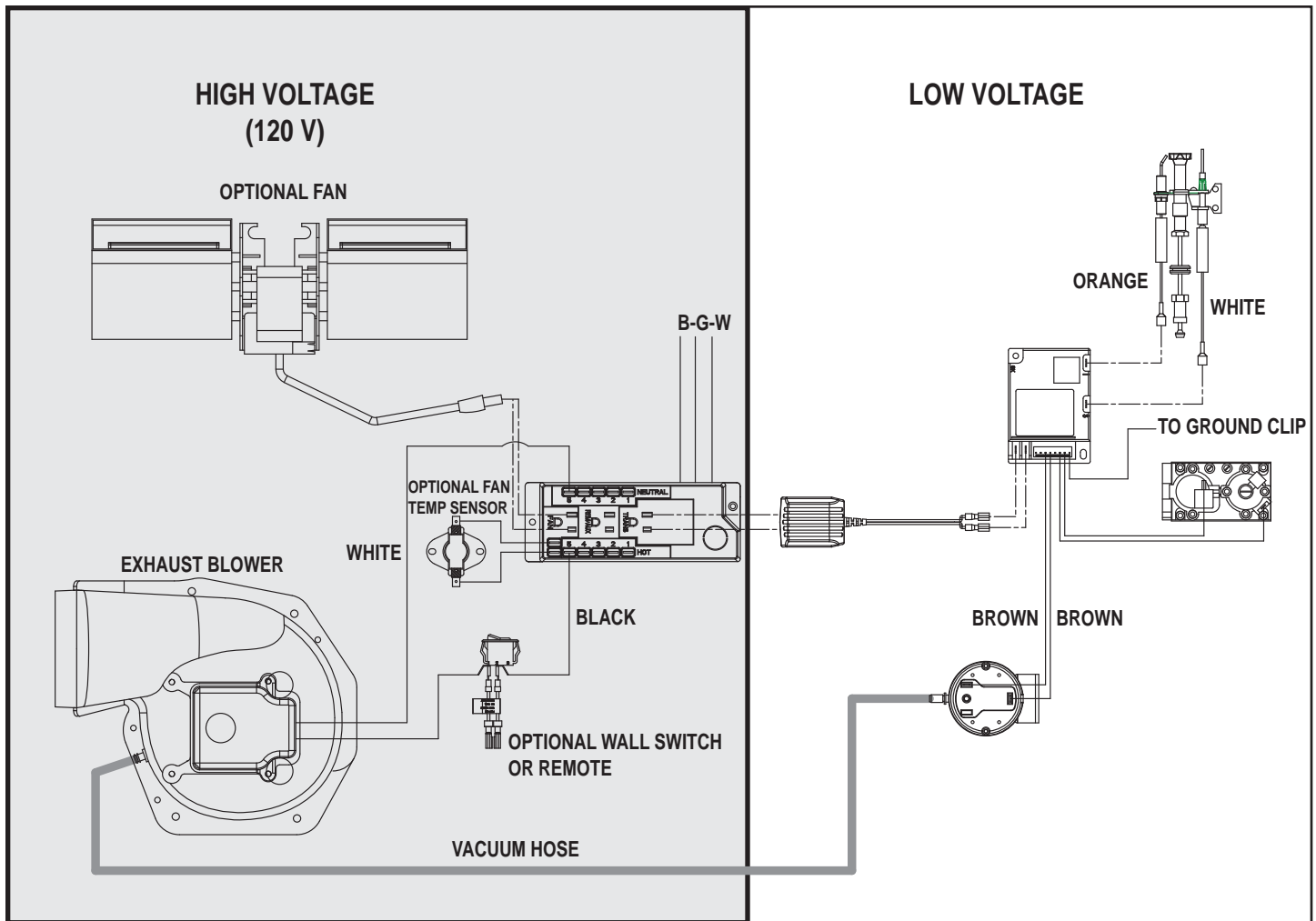

Figure 12.2 IntelliFire Pilot Ignition (IPI) Wiring Diagram

D. Electrical Service and Repair

WARNING! Risk of Shock! Label all wires prior to disconnection when servicing controls. Wiring errors can cause improper and dangerous operation. Verify proper operation after servicing.

WARNING! Risk of Shock! Replace damaged wire with type 105° C rated wire. Wire must have high temperature insulation.

E. Junction Box Installation

1. Disconnect junction box from bracket by removing one screw.
2. Install wire strain relief into junction box bracket.
- 3. Route 110-120V wire through strain relief.
4. Secure ground and connect incoming hot and neutral wires to the corresponding wires from junction box.
5. Tighten strain relief and reattach junction box to bracket with one screw.

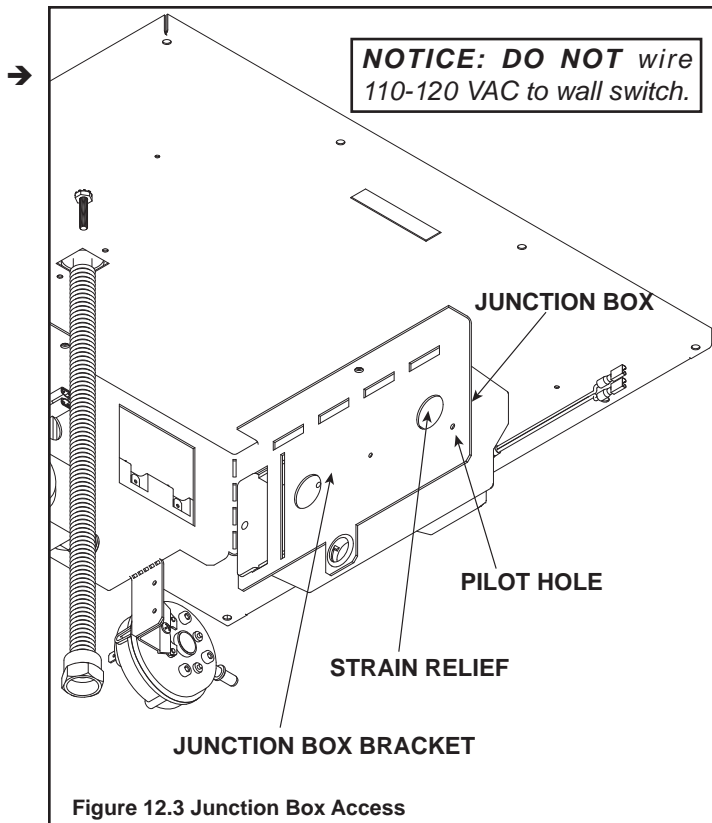

13 Finishing

A. Mantel and Wall Projections

WARNING! Risk of Fire! Comply with all minimum clearances as specified. Framing or finishing material closer than the minimums listed must be constructed entirely of noncombustible materials (i.e., steel studs, concrete board, etc).

Combustible Mantels

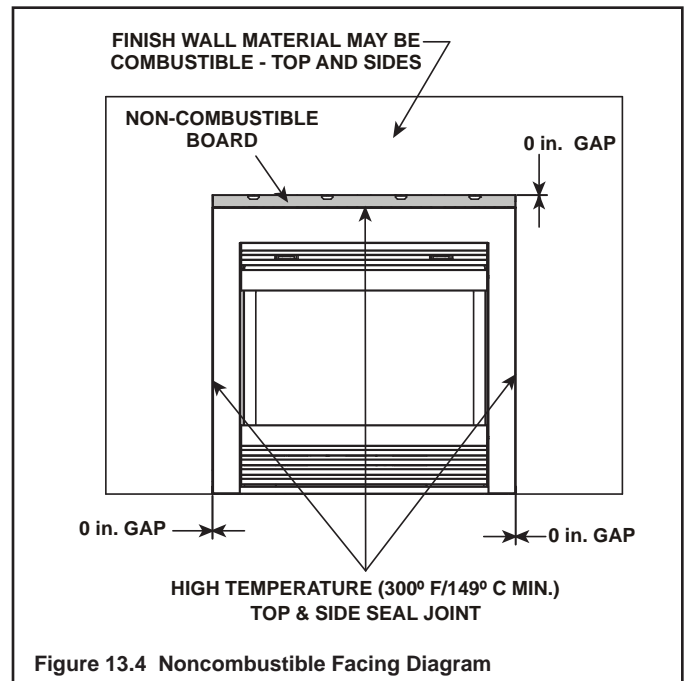
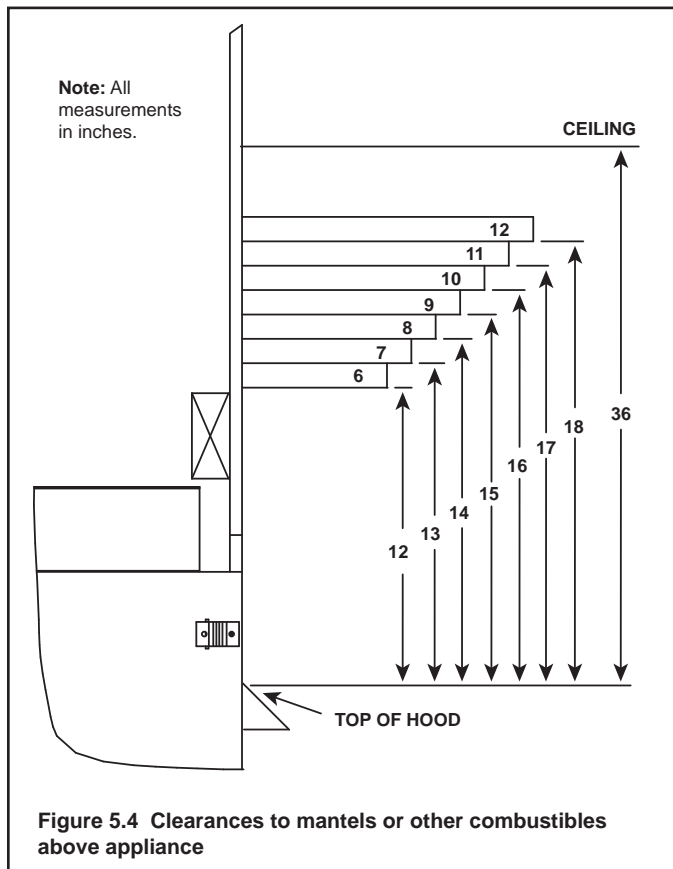

B. Facing Material

- Metal front faces may be covered with non-combustible materials only.
- Facing and/or finishing materials must not interfere with air flow through louvers, operation of louvers or doors, or access for service.
- Facing and/or finishing materials must never overhang into the glass opening.
- Observe all clearances when applying combustible materials.
- Seal joints between the finished wall and appliance top and sides using a 300 °F minimum sealant. Refer to Figure 13.16.

WARNING! Risk of Fire! DO NOT apply combustible materials beyond the minimum clearances. Comply with all minimum clearances to combustibles as specified in this manual. Overlapping materials could ignite and will interfere with proper operation of doors and louvers.

14 Appliance Setup

A. Remove Glass Assembly

See Section 14.H.

B. Remove Shipping Materials

Remove shipping materials from inside or underneath the firebox.

C. Remove Grate Shipping Support

- Remove the log pack and hood, if applicable.
- Bend top retaining tab of grate shipping support into vertical position (see Figure 12.1).
- Lift grate slightly upward with one hand so that the grate clears the support.
- Slide shipping support to side, remove and discard.
- Lower grate onto refractory.

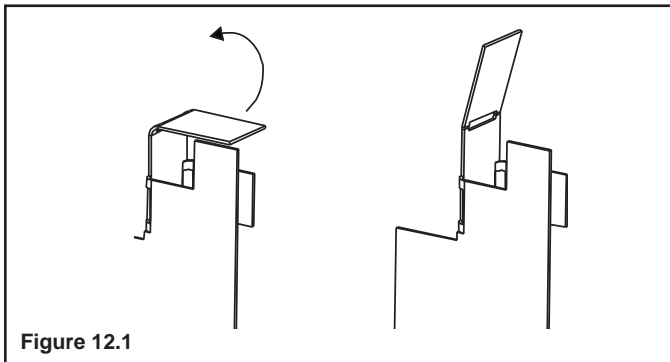

D. Clean the Appliance

Clean/vacuum any sawdust or construction debris that may have accumulated inside the firebox or underneath in the control cavity.

E. Accessories

Install approved accessories per instructions included with accessories. Contact your dealer for a list of approved accessories.

WARNING! Risk of Fire and Electric Shock! Use ONLY Hearth & Home Technologies-approved optional accessories with this appliance. Using non-listed accessories could result in a safety hazard and will void the warranty.

F. Ember Placement

WARNING! Risk of Explosion! Follow ember placement instructions in manual. DO NOT place embers directly over burner ports. Replace ember material annually. Improperly placed embers interfere with proper burner operation.

Placing the Ember Material

Ember material is shipped with this gas appliance. To place the ember material:

- When placing Glowing Embers[®] onto the burner care should be taken so that the ports are not covered. Place the dime-size ember pieces about 1/2 inch apart near port holes in burner top, but not on or in between the ports. For best performance do NOT place embers on ports at rear of burner (see Figure 12.2). Failure to follow this procedure will likely cause lighting and sooting problems.
- Save the remaining ember materials for use during appliance servicing. The embers provided should be enough for 3 to 5 applications.

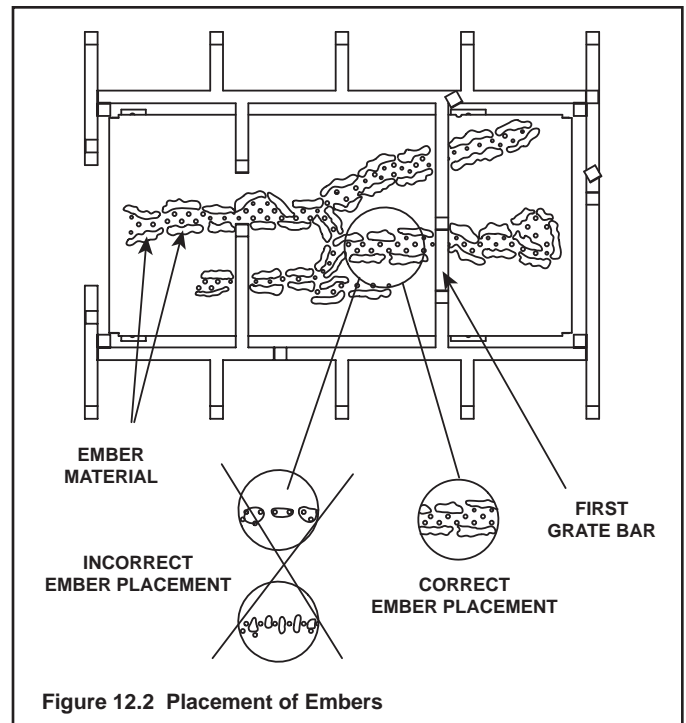

G. Positioning the Logs

If the gas logs have been factory installed they should not need to be positioned. If the logs have been packaged separately, refer to the following instructions.

Log Assembly: LOGS-GATEWAY

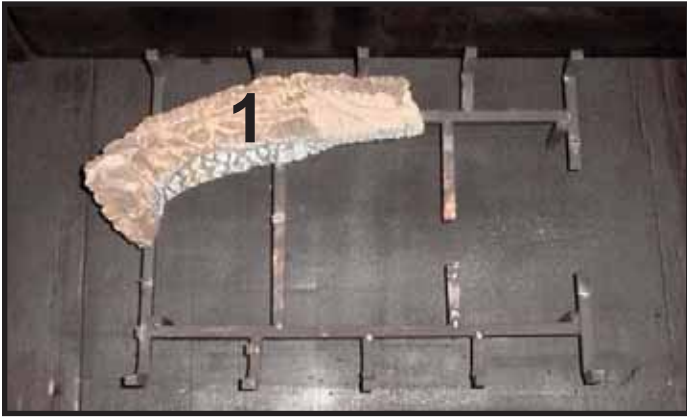

LOG #1 (SRV288-721): Position log #1 at the rear left corner of the grate against three grate stops as shown.

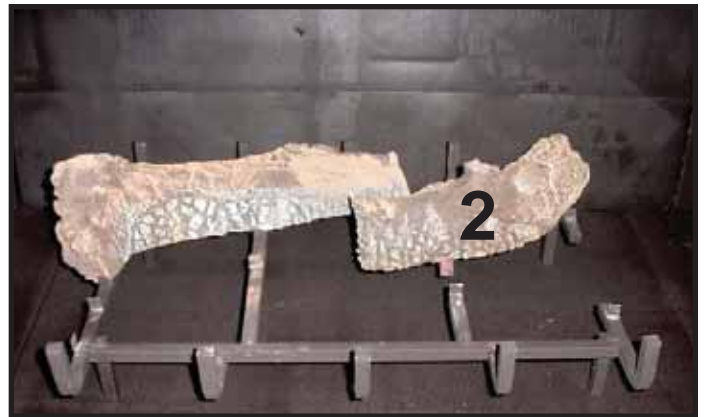
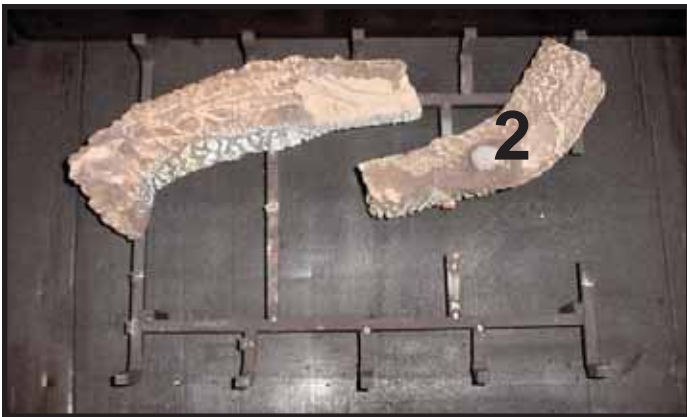

LOG #2 (SRV675-722): Place log #2 so that the slot on the bottom of the log fits over the grate tab in the right rear corner. The left end of log #2 rests against the stop on the right center bar.



LOG #3 (SRV288-726): Position log #3 on the front right hand side of the grate against the 3 stops.

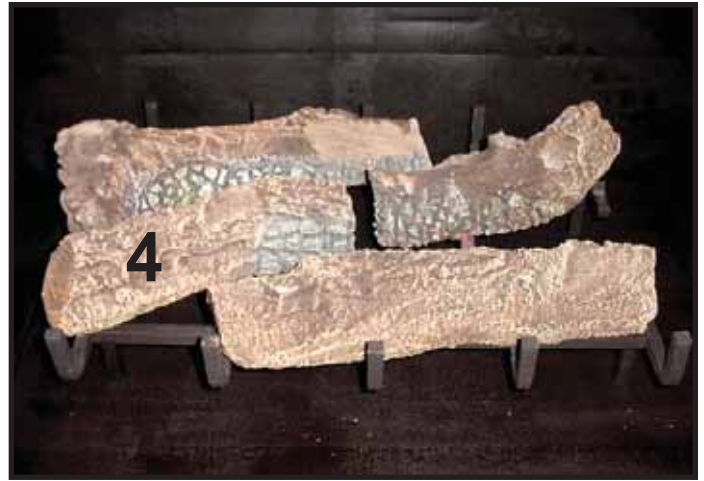
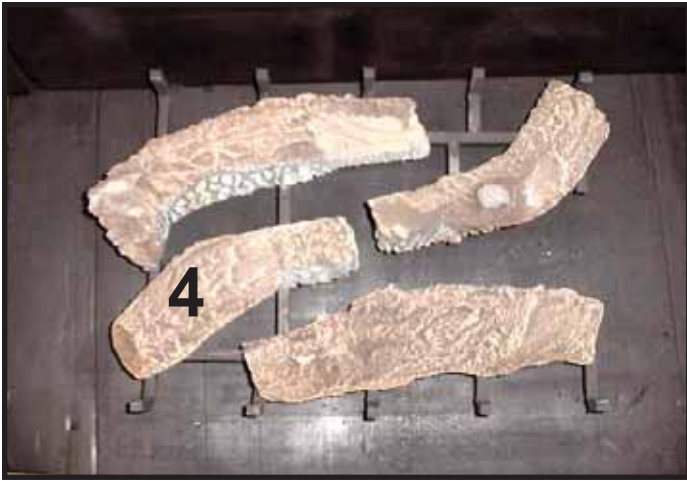

LOG #4 (SRV288-723): Place log #4 so that the slot on the bottom of the log fits over the grate tab on the front left corner of the grate. The right end of log #4 rests against the stop on the left center bar.

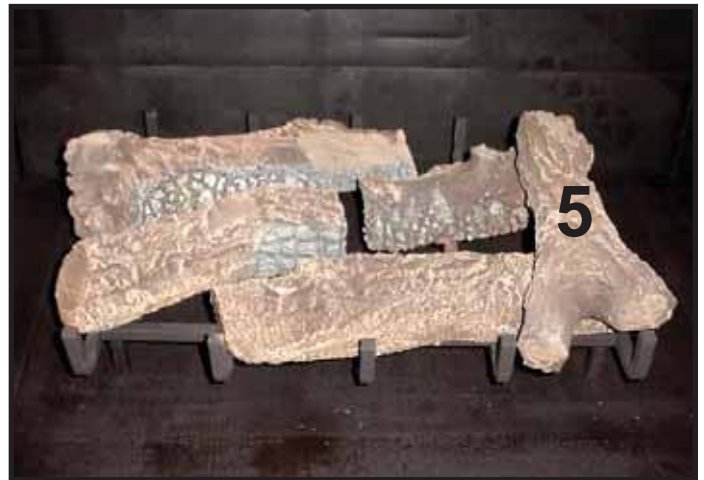

LOG #5 (SRV285-720): Position log #5 on the location grooves on log #2 and log #3 as shown.



LOG #6 (SRV278-705): Place the “Y” end of log #6 over the second rear grate bend and locate its top in the locating groove on log #2.



LOG #7 (SRV285-725): Position log #7 on the locating grooves on log #3 and log #4 as shown.

H. Fixed Glass Assembly

Removing Fixed Glass Assembly

WARNING! Risk of Asphyxiation! Handle fixed glass assembly with care. Inspect the gasket to ensure it is undamaged and inspect the glass for cracks, chips or scratches.

- **DO NOT** strike, slam or scratch glass.
- **DO NOT** operate fireplace with glass removed, cracked, broken or scratched.
- Replace as a complete assembly.

Removing Fixed Glass Assembly

• Pull the four glass assembly latches out of the groove on the glass frame. Remove glass door from the appliance. See Figure 14.3.

Replacing Fixed Glass Assembly

• Replace the glass door on the appliance. Pull out and latch the four glass assembly latches into the groove on the glass frame.

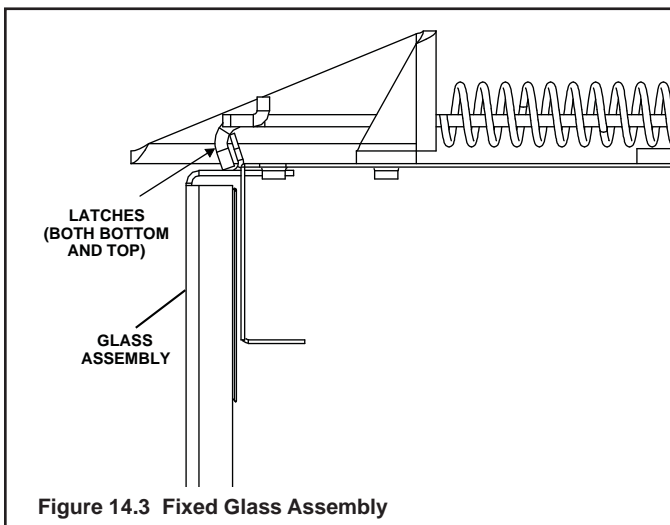

Figure 14.3 Fixed Glass Assembly

I. Install the Mesh

The screen mesh is a protective barrier and must be attached.

J. Install Trim and/or Surround

- Install optional trim kits and/or surrounds using the instructions included with the accessory.
- Use non-combustible materials to cover the gap between the sheet rock and the appliance.
- Do not obstruct or modify the air inlet/outlet grilles or hood. When overlapping on both sides, leave enough space so that the bottom grille can be lowered and the trim door removed.

K. Install Hood

L. Air Shutter Setting

Air shutter settings should be adjusted by a qualified service technician at the time of installation. The air shutter is set at the factory for minimum vertical vent run. Adjust air shutter for longer vertical runs. See Figure 14.4.

- Loosen the wing nut.
- Push the air handle in to close the air shutter.
- Pull the air handle out to open the air shutter.
- Tighten the wing nut.

NOTICE: If sooting occurs, provide more air by opening the air shutter.

Air Shutter Settings

	NG	LP
Burner	1/4 in.	Fully Open

15 Troubleshooting

With proper installation, operation, and maintenance your gas appliance will provide years of trouble-free service. If you do experience a problem, this troubleshooting guide will assist a qualified service technician in the diagnosis of a problem and the corrective action to be taken. This troubleshooting guide can only be used by a qualified service technician. Contact your dealer to arrange a service call by a qualified service technician.

A. IntelliFire Ignition System

Symptom	Possible Cause	Corrective Action
1. Pilot won't light. The ignitor/module makes noise, but no spark.	A. Incorrect wiring.	Verify "S" wire (white) for sensor and "I" wire (orange) for ignitor are connected to correct terminals on module and pilot assembly.
	B. Loose connections or electrical shorts in the wiring.	Verify no loose connections or electrical shorts in wiring from module to pilot assembly. Verify connections underneath pilot assembly are tight; also verify connections are not grounding out to metal chassis, pilot burner, pilot enclosure, mesh screen if present, or any other metal object.
	C. Ignitor gap is too large.	Verify gap of igniter to right side of pilot hood. The gap should be approximately .17 in. or 1/8 in. (3 mm).
	D. Module.	Turn ON/OFF rocker switch or wall switch to OFF position. Remove ignitor wire "I" from module. Place a grounded wire about 3/16 in. (5 mm) away from "I" terminal on module. Place ON/OFF rocker switch or wall switch in ON position. If there is no spark at "I" terminal module must be replaced. If there is a spark at "I" terminal, module is fine. Inspect pilot assembly for shorted sparker wire or cracked insulator around electrode. Replace pilot if necessary.
2. Pilot won't light, there is no noise or spark.	A. No power or transformer installed incorrectly.	Verify that transformer is installed and plugged into module. Check voltage of transformer under load at spade connection on module with ON/OFF switch in ON position. Acceptable readings of a good transformer are between 3.2 and 2.8 volts AC.
	B. A shorted or loose connection in wiring configuration or wiring harness.	Remove and reinstall the wiring harness that plugs into module. Verify there is a tight fit. Verify pilot assembly wiring to module. Remove and verify continuity of each wire in wiring harness. Replace any damaged components.
	C. Improper wall switch wiring.	Verify that 110-120 VAC power is "ON" to junction box. ←
	D. Module not grounded.	Verify black ground wire from module wire harness is grounded to metal chassis of appliance.
	E. Module.	Turn ON/OFF rocker switch or wall switch to OFF position. Remove ignitor wire "I" from module. Place ON/OFF rocker switch or wall switch in ON position. If there is no spark at "I" terminal module must be replaced. If there is a spark at "I" terminal, module is fine. Inspect pilot assembly for shorted sparker wire or cracked insulator around electrode.
3. Pilot sparks, but Pilot will not light.	A. Gas supply.	Verify that incoming gas line ball valve is "open". Verify that inlet pressure reading is within acceptable limits, inlet pressure must not exceed 14 in. W.C.
	B. Ignitor gap is too large.	Verify gap of igniter to right side of pilot hood. The gap should be approximately .17 in. or 1/8 in. (3 mm).
	C. Module is not grounded.	Verify module is securely grounded to metal chassis of appliance.

IntelliFire Ignition System - (continued)

Symptom	Possible Cause	Corrective Action
4. Pilot lights but continues to spark, and main burner will not ignite. (If the pilot continues to spark after the pilot flame has been lit, flame rectification has not occurred.)	A. Vacuum Switch.	Verify that the brown wires are connected to the vacuum switch. Verify that the vacuum hose is connected from the vacuum switch to the exhaust blower. Verify that there are no kinks in vacuum hose line.
	B. A shorted or loose connection in flame sensing rod.	Verify all connections to wiring diagram in manual. Verify connections underneath pilot assembly are tight. Verify connections are not grounding out to metal chassis, pilot burner, pilot enclosure or screen if present, or any other metal object.
	C. Poor flame rectification or contaminated flame sensing rod.	With fixed glass assembly in place, verify that flame is engulfing flame sensing rod on left side of pilot hood. Flame sensing rod should glow shortly after ignition. Verify correct pilot orifice is installed and gas inlet is set to pressure specifications. Polish flame sensing rod with fine steel wool to remove any contaminants that may have accumulated on flame sensing rod.
	D. Module is not grounded.	Verify module is securely grounded to metal chassis of appliance. Verify that wire harness is firmly connected to the module.
	E. Damaged pilot assembly or contaminated flame sensing rod.	Verify that ceramic insulator around the flame sensing rod is not cracked, damaged, or loose. Verify connection from flame sensing rod to white sensor wire. Polish flame sensing rod with fine steel wool to remove any contaminants that may have accumulated on flame sensing rod. Verify continuity with a multimeter with ohms set at lowest range. Replace pilot if any damage is detected.
	F. Module.	Turn ON/OFF rocker switch or wall switch to OFF position. Remove ignitor wire "I" from module. Place ON/OFF rocker switch or wall switch in ON position. If there is no spark at "I" terminal module must be replaced. If there is a spark at "I" terminal, module is fine.

16 Reference Materials

A. Appliance Dimension Diagram

Dimensions are actual appliance dimensions. Use for reference only. For framing dimensions and clearances refer to Section 5.

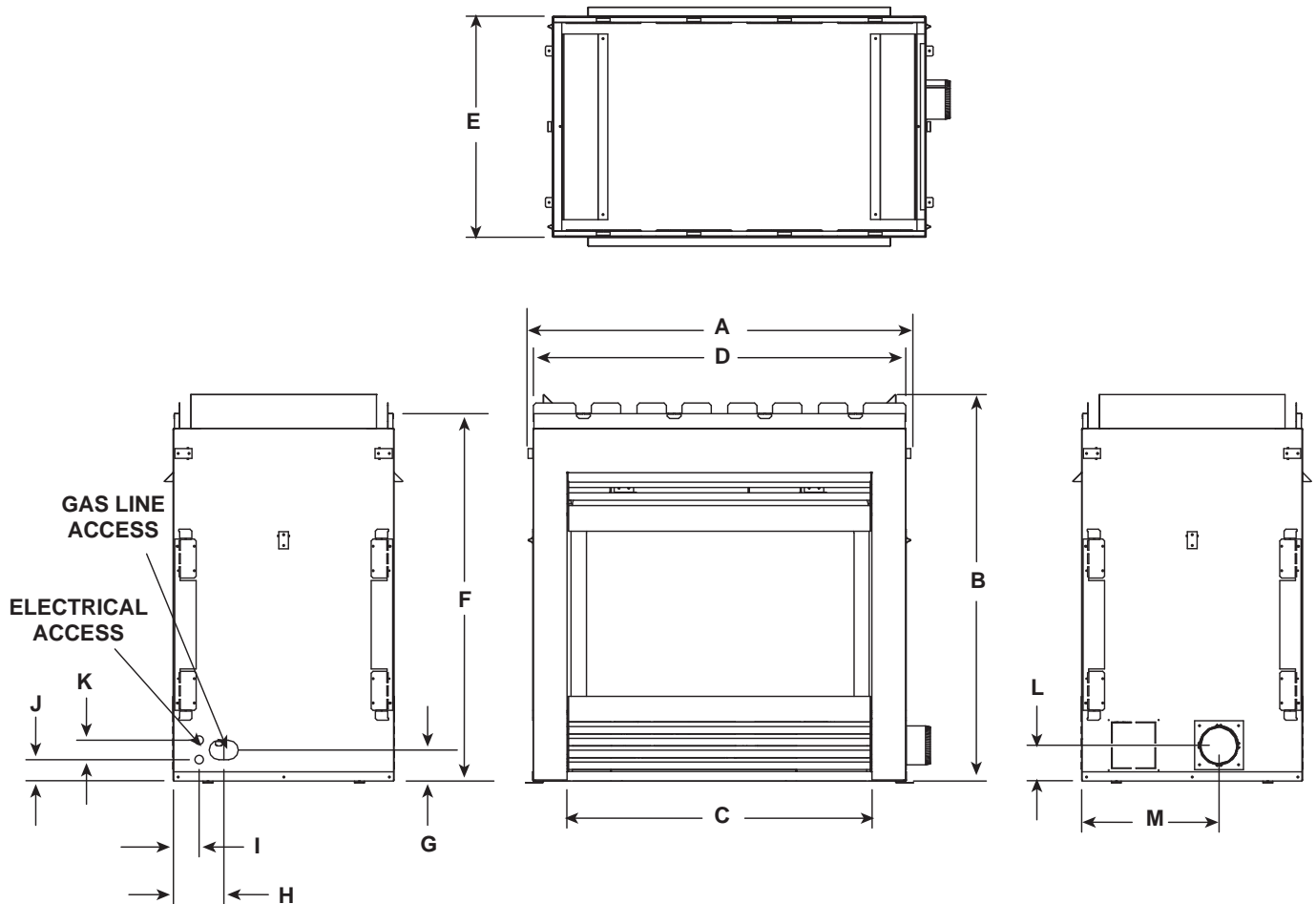

Appliance Dimensions Table

Location	Inches	Millimeters
A	39-1/4	997
B	39-9/16	1005
C	31-1/4	794
D	38-1/8	968
E	22-5/8	575
F	37-5/8	955
G	3-1/8	80

Location	Inches	Millimeters
H	5-1/8	131
I	2-5/8	67
J	2-1/8	54
K	2	51
L	3-5/8	92
M	14-1/16	357

Figure 16.1 Appliance Dimensions

B. Vent Components Diagrams

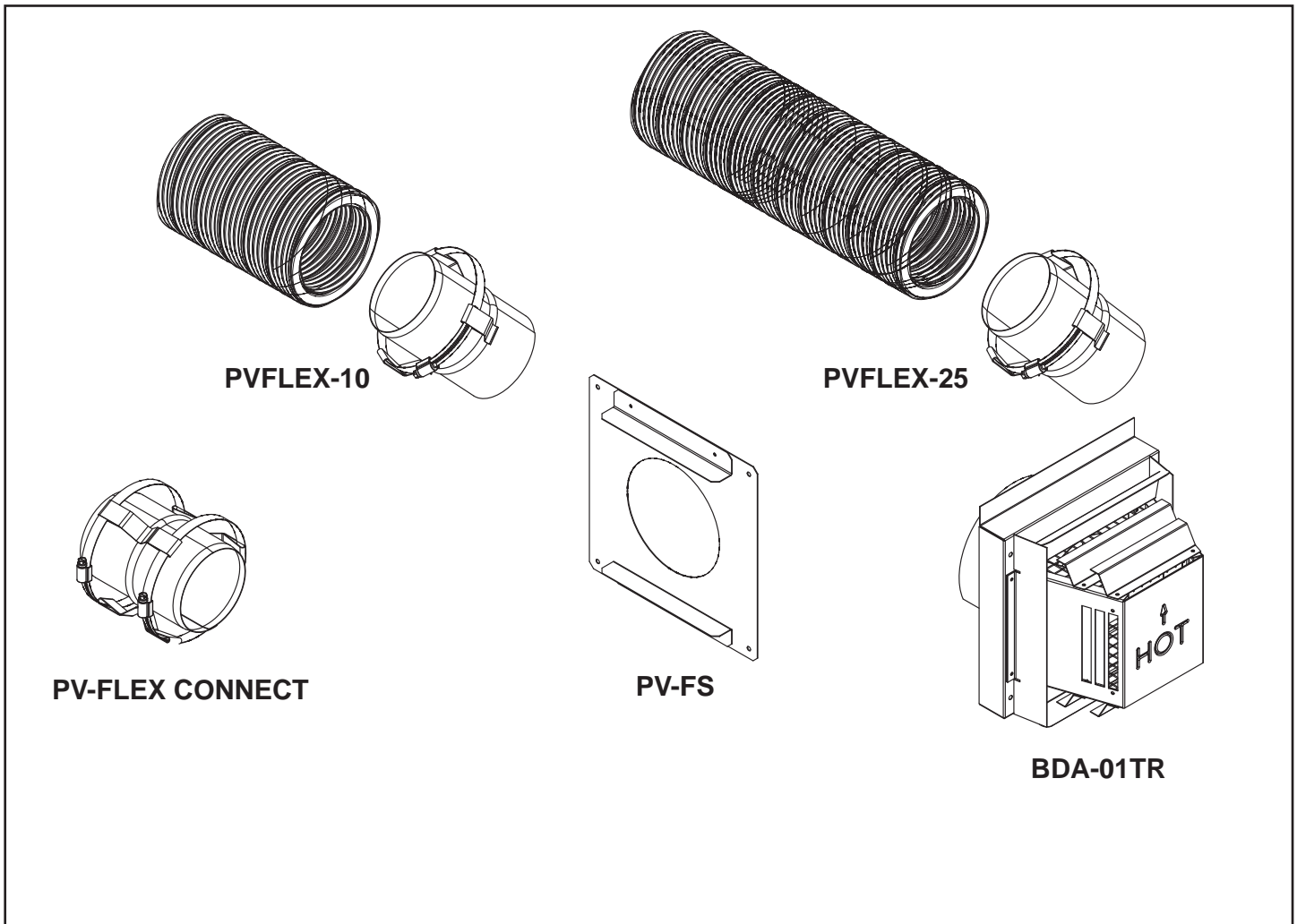

OPTIONAL AK-TV KIT CONTENTS

Duct Termination

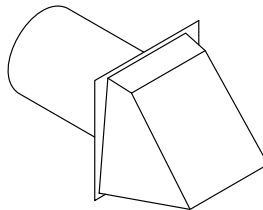

Side Collar (2)

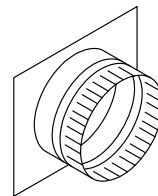

Screws (8)



Flex Duct

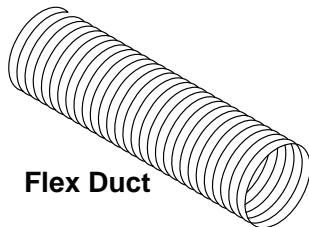

Plastic Tie Strap (4)

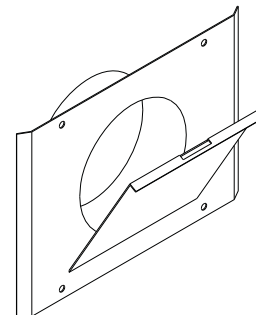

Damper Assembly

Log Set Assembly

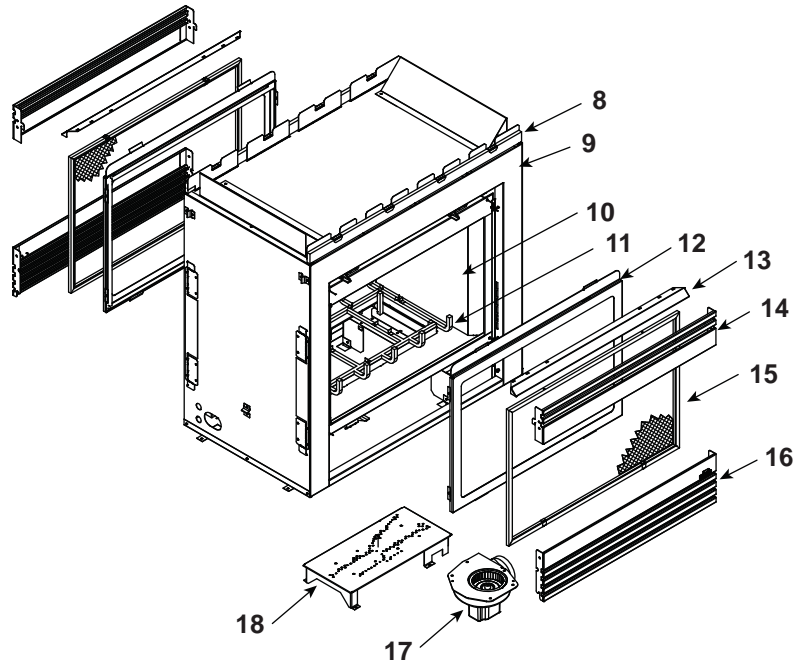
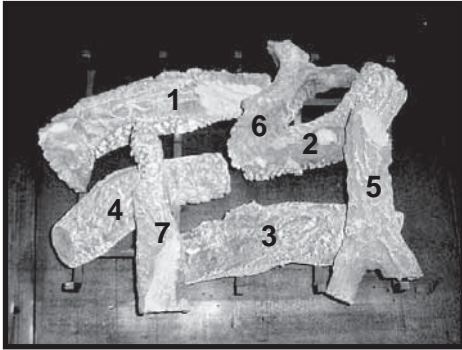

IMPORTANT: THIS IS DATED INFORMATION. When requesting service or replacement parts for your appliance please provide model number and serial number. All parts listed in this manual may be ordered from an authorized dealer.



Stocked at Depot

ITEM	DESCRIPTION	COMMENTS	PART NUMBER	
	Log Set Assembly		LOGS-GATEWAY	Y
1	Log 1		SRV288-721	
2	Log 2		SRV675-722	
3	Log 3		SRV288-726	
4	Log 4		SRV288-723	
5	Log 5		SRV285-720	
6	Log 6		SRV278-705	
7	Log 7		SRV285-725	
8	Non-combustible Board		288-401	
9	Surround		288-130	
10	Side Refractory		288-280	
11	Log Grate		288-360A	
12	Glass Door Assembly		GLA-GATEWAY	Y
13	Hood		288-174	
14	Louver Assembly, Top		288-252A	
15	Trim Door Mesh		288-031	Y
16	Louver Assembly, Bottom		288-249A	
17	Blower Assembly		288-125A	Y
18	Burner NG		288-176A	Y
	Burner LP		288-175A	Y

Additional service part numbers appear on following page.

3/13

No one builds a better fire

Beginning Manufacturing Date: Jan 2002
Ending Manufacturing Date: Active

#19 Valve Assembly

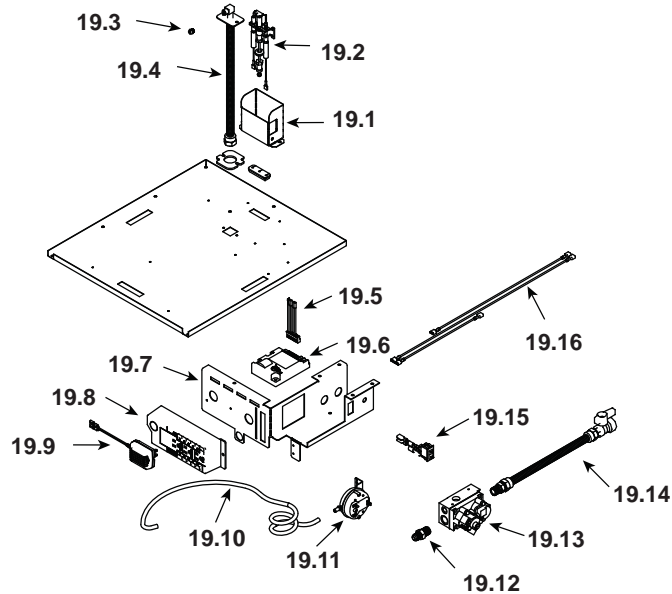

IMPORTANT: THIS IS DATED INFORMATION. When requesting service or replacement parts for your appliance please provide model number and serial number. All parts listed in this manual may be ordered from an authorized dealer.



**Stocked
at Depot**

ITEM	DESCRIPTION	COMMENTS	PART NUMBER	Stocked at Depot
19.1	Pilot Bracket		288-163	
19.2	Pilot Assembly NG		385-510A	Y
	Pilot Assembly LP		385-511A	Y
19.3	Burner Orifice (#32A) NG	Pre Aug 2009	420-800	Y
	Burner Orifice (#32C) NG	Post Aug 2009	582-832	Y
	Burner Orifice (#50A) LP	Pre Aug 2009	446-801	Y
	Burner Orifice (#50C) LP	Post Aug 2009	582-850	Y
19.4	Flexible Gas Connector	Pre Aug 2009	477-301A	Y
		Post Aug 2009	383-302A	Y
19.5	Wire Assembly		288-593A	Y
19.6	Module		593-592	Y
19.7	Valve Bracket		288-145	
19.8	Junction Box and Wire Assembly	Pre Aug 2009	4021-013/288-050	Y
	Junction Box	Post Aug 2009	4021-013	Y
19.9	3V Adaptor Plug		593-593A	Y
19.10	Vacuum Hose (Teflon Tube)		421-9	
19.11	Vacuum Switch		288-521	Y
19.12	Male connector	Pkg of 5	303-315/5	Y
19.13	Valve NG		593-500	Y
	Valve LP		593-501	Y
19.14	Flex Ball Valve Assembly		302-320A	Y
19.15	ON/OFF Rocker Switch		060-521A	Y
19.16	Wire Assembly	Pre Aug 2009	N/A	
		Post Aug 2009	288-050	Y

Additional service part numbers appear on following page.

