

Installation Manual

Installation and Appliance Setup

CAUTION! Risk of Fire! DO NOT store instruction manuals inside fireplace cavity. High temperatures could cause a fire.

INSTALLER: Leave this manual with the appliance, not inside the appliance.

CONSUMER: Retain this manual for future reference. Do not store inside the appliance. Contact your dealer with questions regarding installation, operation or service.

NOTICE: DO NOT discard this manual!

heatilator
The first name in fireplaces

Models:

NNXT33-IFT

NNXT33L-IFT

NNXT36-IFT

NNXT36L-IFT

GAS-FIRED

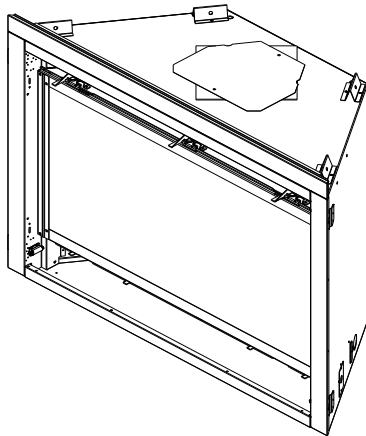

This appliance may be installed as an OEM installation in manufactured home (USA only) or mobile home and must be installed in accordance with the manufacturer's instructions and the *Manufactured Home Construction and Safety Standard, Title 24 CFR, Part 3280* in the United States, or the *Standard for Installation in Mobile Homes, CAN/CSA Z240 MH Series*, in Canada.

This appliance is only for use with the type(s) of gas indicated on the rating plate. This appliance is not convertible for use with other gases, unless a certified kit is used.

⚠ WARNING:

FIRE OR EXPLOSION HAZARD

Failure to follow safety warnings exactly could result in serious injury, death, or property damage.

- **DO NOT** store or use gasoline or other flammable vapors and liquids in the vicinity of this or any other appliance.
- **What to do if you smell gas**
 - **DO NOT** try to light any appliance.
 - **DO NOT** touch any electrical switch. **DO NOT** use any phone in your building.
 - Leave the building immediately.
 - Immediately call your gas supplier from a neighbor's phone. Follow the gas supplier's instructions.
 - If you cannot reach your gas supplier, call the fire department.
- Installation and service must be performed by a qualified installer, service agency, or the gas supplier.

! DANGER



HOT GLASS WILL CAUSE BURNS.

DO NOT TOUCH GLASS UNTIL COOLED.

NEVER ALLOW CHILDREN TO TOUCH GLASS.

A barrier designed to reduce the risk of burns from the hot viewing glass is provided with this appliance and must be installed for the protection of children and other at-risk individuals.

Pour demander un exemplaire en français de ce manuel d'installation, visitez www.heatilator.com.

Decorative barrier front must be ordered separately at time of appliance purchase. See Section 3.A.

▲ Safety Alert Key:

- **DANGER!** Indicates a hazardous situation which, if not avoided will result in death or serious injury.
- **WARNING!** Indicates a hazardous situation which, if not avoided could result in death or serious injury.
- **CAUTION!** Indicates a hazardous situation which, if not avoided, could result in minor or moderate injury.
- **NOTICE:** Used to address practices not related to personal injury.

Note: The term “recommend” or “recommended” does not indicate a requirement. It is a best practice suggested by Hearth & Home Technologies®. Failure to perform the recommended task will not result in a safety concern.

Table of Contents

→ Installation Standard Work Checklist	3	7 Venting and Chimneys	
1 Product Specific and Important Safety Information		A. Assemble Vent Sections (DVP Pipe Only)	32
A. Appliance Certification	4	B. Assemble Slip Sections	34
B. Glass Specifications	4	C. Secure the Vent Sections	34
C. BTU Specifications	4	D. Disassemble Vent Sections	35
D. High Altitude Installations	4	E. Vertical Termination Requirements	35
E. Non-Combustible Materials Specification	4	F. Horizontal Termination Requirements	36 ←
F. Combustible Materials Specification	4	G. Shrouds	38
G. Electrical Codes	4	8 Electrical Information	
H. California	4	A. General Information	39
I. Requirements for the Commonwealth of Massachusetts	5	B. Wiring Requirements	40
2 Getting Started		9 Gas Information	
A. Design and Installation Considerations	6	A. Fuel Conversion	42
B. Good Faith Wall Surface	6	B. Gas Pressure	42
C. Tools and Supplies Needed	6	C. Gas Connection	42
D. Inspect Appliance and Components	7	D. High Altitude Installations	42
3 Framing and Clearances		E. Air Shutter Setting	43
A. Appliance/Decorative Front Dimension Diagrams	8	10 Finishing	
B. Appliance Location and Clearances to Combustibles	10	A. Facing Material	44
→ C. Constructing the Appliance Chase	12	B. Mantel and Wall Projections	44
D. Floor Protection	13	C. Non-combustible Mantel and Wall Projections	45
4 Termination Location and Vent Information		11 Appliance Setup	
A. Approved Pipe	14	A. Remove the Shipping Materials	46
→ B. Vent Termination Minimum Clearances	14	B. Clean the Appliance	46
C. Vent Terminal Clearances	15	C. Install Burner Media / Embers	46
D. Use of Elbows	16	D. Install Control Heat Shield	47
→ E. Vent Diagrams	17	E. Install Fixed Glass Assembly	47
5 Vent Clearances and Framing		F. Install Decorative Barrier Front	47
→ A. Pipe Clearances to Combustibles	27	G. Install Logs	48
B. Wall Penetration Framing/Firestops	27	12 Reference Materials	
C. Ceiling Firestop/Floor Penetration Framing	28	A. Approved Vent Components List	50 ←
D. Install Attic Insulation Shield	28	B. Optional Components	51
6 Appliance Preparation		C. Accessories	51
A. Top Vent	29		
B. Prepare For Heat Management	31		
C. Securing and Leveling the Appliance	31		

→ = Contains updated information.

→ Installation Standard Work Checklist

ATTENTION INSTALLER:
Follow this Standard Work Checklist

This standard work checklist is to be used by the installer in conjunction with, not instead of, the instructions contained in this installation manual.

Customer: _____
Lot/Address: _____

Date Installed: _____
Location of Fireplace: _____

Model (circle one): NNXT33-IFT, NNXT33L-IFT
NNXT36-IFT, NNXT36L-IFT

Installer: _____
Dealer/Distributor Phone # _____
Serial #: _____

 **WARNING! Risk of Fire or Explosion!** Failure to install appliance according to these instructions could lead to a fire or explosion. Install **ONLY** components and accessories approved by Hearth & Home Technologies. Unapproved components and accessories could cause fireplace to overheat.

Appliance Install

Verified that the chase is insulated and sealed. (Pg. 12)
Verified clearances to combustibles. (Pg. 10-11)
Fireplace is leveled and secured. (Pg. 31)

YES

IF NO, WHY?

Venting/Chimney Section 7 (Pg 32-38)

Venting configuration complies to vent diagrams.
Venting installed, locked and secured in place with proper clearance.
Firestops installed.
Attic insulation shield installed.
Exterior wall/Roof flashing installed and sealed.
Terminations installed and sealed.

Electrical Section 8 (Pg 39-41)

Unswitched power (110-120 VAC) provided to the appliance.
Switch wires properly installed.

Gas Section 9 (Pg 42-43)

Proper appliance for fuel type.
Was a conversion performed?
Leak check performed and inlet pressure verified.
Verified proper air shutter setting for installation type.

Finishing Section 10 (Pg 44-45)

Combustible materials not installed in non-combustible areas.
Verified all clearances meet installation manual requirements.
Mantels and wall projections comply with installation manual requirements.

Appliance Setup Section 11 (Pg 46-49)

All packaging and protective materials removed (inside & outside of appliance).
Refractories, logs, mineral wool and lava rock installed correctly.
Glass assembly installed and secured.
Accessories installed properly.
Decorative barrier front properly installed.
Manual bag and all of its contents are removed from inside/under the appliance and given to party responsible for use and operation.
Started appliance and verified no gas leaks exist.

Hearth & Home Technologies recommends the following:

- Photographing the installation and copying this checklist for your file.
- That this checklist remain visible at all times on the appliance until the installation is complete.

Comments: Further description of the issues, who is responsible (Installer/ Builder/ Other Trades, etc) and corrective action needed _____

Comments Communicated to party responsible _____ by _____ on _____
(Builder / Gen. Contractor/) (Installer) (Date)

→ = Contains updated information.

1 Product Specific and Important Safety Information

A. Appliance Certification

MODELS: NNXT33-IFT, NNXT33L-IFT, NNXT36-IFT, NNXT36L-IFT

LABORATORY: Underwriters Laboratories, Inc. (UL)

TYPE: Direct Vent Heater

STANDARD: CSA / ANSI Z21.88:19 • CSA 2.33:19

This product is listed to ANSI standards for “Vented Gas Fireplace Heaters” and applicable sections of “Gas Burning Heating Appliances for Manufactured Homes and Recreational Vehicles”, and “Gas Fired Appliances for Use at High Altitudes”.

NOTICE: This installation must conform with local codes. In the absence of local codes you must comply with the National Fuel Gas Code, ANSI Z223.1-latest edition in the U.S.A. and the CAN/CGA B149 Installation Codes in Canada.

NOT INTENDED FOR USE AS A PRIMARY HEAT SOURCE.

This appliance is tested and approved as either supplemental room heat or as a decorative appliance. It should not be factored as primary heat in residential heating calculations.

B. Glass Specifications

This appliance is equipped with 5 mm ceramic glass. Replace glass only with 5 mm ceramic glass. Please contact your dealer for replacement glass.

C. BTU Specifications

Models (U.S. or Canada)		Maximum Input BTU/h	Minimum Input BTU/h	Orifice Size
NNXT33-IFT (NG)	(0-2000 FT)	29,000	16,000	#39
NNXT33L-IFT (Propane)	(0-2000 FT)	28,000	15,750	1.55 mm
NNXT36-IFT (NG)	(0-2000 FT)	31,000	18,500	#37
NNXT36L-IFT (Propane)	(0-2000 FT)	29,000	15,500	#52

D. High Altitude Installations

NOTICE: If the heating value of the gas has been reduced, these rules do not apply. Check with your local gas utility or authorities having jurisdiction.

When installing above 2000 feet elevation:

- In the USA: Reduce input rate 4% for each 1000 feet above 2000 feet.
- In CANADA: Input ratings are certified without a reduction of input rate for elevations up to 4500 feet (1370 m) above sea level. Please consult provincial and/or local authorities having jurisdiction for installations at elevations above 4500 feet (1370 m).

Check with your local gas utility to determine proper orifice size.

E. Non-Combustible Materials Specification

Material which will not ignite and burn. Such materials are those consisting entirely of steel, iron, brick, tile, concrete, slate, glass or plasters, or any combination thereof.

Materials that are reported as passing **ASTM E 136, Standard Test Method for Behavior of Materials in a Vertical Tube Furnace at 750 °C** shall be considered non-combustible materials.

F. Combustible Materials Specification

Materials made of or surfaced with wood, compressed paper, plant fibers, plastics, or other material that can ignite and burn, whether flame proofed or not, or plastered or unplastered shall be considered combustible materials.

G. Electrical Codes

NOTICE: This appliance must be electrically wired and grounded in accordance with local codes or, in the absence of local codes, with **National Electric Code ANSI/NFPA 70-latest edition or the Canadian Electric Code CSA C22.1.**

- A 110-120 VAC circuit for this product must be protected with ground-fault circuit-interrupter protection, in compliance with the applicable electrical codes, when it is installed in locations such as in bathrooms or near sinks.

H. California



WARNING: This product and the fuels used to operate this product (liquid propane or natural gas), and the products of combustion of such fuels, can expose you to chemicals including benzene, which is known to the State of California to cause cancer and reproductive harm. For more information go to: www.P65Warnings.ca.gov.

Note: The following requirements reference various Massachusetts and national codes not contained in this document.

I. Requirements for the Commonwealth of Massachusetts

For all side wall horizontally vented gas fueled equipment installed in every dwelling, building or structure used in whole or in part for residential purposes, including those owned or operated by the Commonwealth and where the side wall exhaust vent termination is less than seven (7) feet above finished grade in the area of the venting, including but not limited to decks and porches, the following requirements shall be satisfied:

Installation of Carbon Monoxide Detectors

At the time of installation of the side wall horizontal vented gas fueled equipment, the installing plumber or gas fitter shall observe that a hard wired carbon monoxide detector with an alarm and battery back-up is installed on the floor level where the gas equipment is to be installed. In addition, the installing plumber or gas fitter shall observe that a battery operated or hard wired carbon monoxide detector with an alarm is installed on each additional level of the dwelling, building or structure served by the side wall horizontal vented gas fueled equipment. It shall be the responsibility of the property owner to secure the services of qualified licensed professionals for the installation of hard wired carbon monoxide detectors.

In the event that the side wall horizontally vented gas fueled equipment is installed in a crawl space or an attic, the hard wired carbon monoxide detector with alarm and battery back-up may be installed on the next adjacent floor level.

In the event that the requirements of this subdivision can not be met at the time of completion of installation, the owner shall have a period of thirty (30) days to comply with the above requirements; provided, however, that during said thirty (30) day period, a battery operated carbon monoxide detector with an alarm shall be installed.

Approved Carbon Monoxide Detectors

Each carbon monoxide detector as required in accordance with the above provisions shall comply with NFPA 720 and be ANSI/UL 2034 listed and IAS certified.

Signage

A metal or plastic identification plate shall be permanently mounted to the exterior of the building at a minimum height of eight (8) feet above grade directly in line with the exhaust vent terminal for the horizontally vented gas fueled heating appliance or equipment. The sign shall read, in print size no less than one-half (1/2) in. in size, "**GAS VENT DIRECTLY BELOW. KEEP CLEAR OF ALL OBSTRUCTIONS**".

Inspection

The state or local gas inspector of the side wall horizontally vented gas fueled equipment shall not approve the installation unless, upon inspection, the inspector observes carbon monoxide detectors and signage installed in accordance with the provisions of 248 CMR 5.08(2)(a)1 through 4.

Exemptions

The following equipment is exempt from 248 CMR 5.08(2)(a)1 through 4:

- The equipment listed in Chapter 10 entitled "Equipment Not Required To Be Vented" in the most current edition of NFPA 54 as adopted by the Board; and
- Product Approved side wall horizontally vented gas fueled equipment installed in a room or structure separate from the dwelling, building or structure used in whole or in part for residential purposes.

MANUFACTURER REQUIREMENTS

Gas Equipment Venting System Provided

When the manufacturer of Product Approved side wall horizontally vented gas equipment provides a venting system design or venting system components with the equipment, the instructions provided by the manufacturer for installation of the equipment and the venting system shall include:

- Detailed instructions for the installation of the venting system design or the venting system components; and
- A complete parts list for the venting system design or venting system.

Gas Equipment Venting System NOT Provided

When the manufacturer of a Product Approved side wall horizontally vented gas fueled equipment does not provide the parts for venting the flue gases, but identifies "special venting systems", the following requirements shall be satisfied by the manufacturer:

- The referenced "special venting system" instructions shall be included with the appliance or equipment installation instructions; and
- The "special venting systems" shall be Product Approved by the Board, and the instructions for that system shall include a parts list and detailed installation instructions.

A copy of all installation instructions for all Product Approved side wall horizontally vented gas fueled equipment, all venting instructions, all parts lists for venting instructions, and/or all venting design instructions shall remain with the appliance or equipment at the completion of the installation.

See Gas Connection section for additional Commonwealth of Massachusetts requirements.

2 Getting Started

A. Design and Installation Considerations

WARNING! Risk of Fire or Explosion! Read all instructions before starting the installation.

Heatilator direct vent gas appliances are designed to operate with all combustion air siphoned from outside of the building and all exhaust gases expelled to the outside. No additional outside air source is required.

Installation **MUST** comply with local, regional, state and national codes and regulations. Consult insurance carrier, local building inspector, fire officials or authorities having jurisdiction over restrictions, installation inspection and permits.

Before installing, determine the following:

- Where the appliance is to be installed.
- The vent system configuration to be used.
- Gas supply piping requirements.
- Provisions for optional heat management system.
- Electrical wiring requirements.
- Framing and finishing details.
- Whether optional accessories—devices such as a fan, wall switch, or remote control—are desired.

Installation and service of this appliance should be performed by qualified personnel. Hearth & Home Technologies recommends HHT Factory Trained or NFI certified professionals.



Improper installation, adjustment, alteration, service or maintenance can cause injury or property damage. For assistance or additional information, consult a qualified service technician, service agency or your dealer.

B. Good Faith Wall Surface

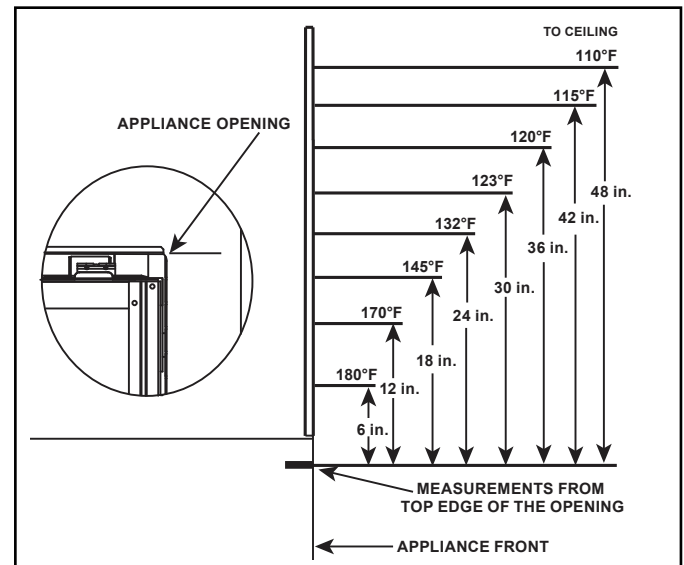

Figure 2.1 Good Faith Wall Surface Temperatures Above Appliance

If installing a television (TV) above the appliance, see Section 3 of the appliance Owner's Manual.

NOTICE: Surface temperatures listed above are taken with a temperature measuring probe as prescribed by the test standard used for appliance certification. Temperatures on walls or mantels taken with an infrared thermometer may yield increased temperatures of up to 30 °F (17 °C) or more depending on the thermometer settings and material characteristics being measured. Use appropriate finishing materials that are able to withstand these conditions. For additional finishing guidelines, see Section 10.

C. Tools and Supplies Needed

Before beginning the installation be sure that the following tools and building supplies are available.

- | | |
|---|-----------------------------------|
| Hand Tools | Tape measure |
| Level | Framing material |
| Manometer | Framing square |
| Voltmeter | Electric drill and bits (1/4 in.) |
| Plumb line | Safety glasses/Gloves |
| Wrenches | Reciprocating saw |
| 1/4 in. nut driver | |
| Non-corrosive leak check solution | |
| 1/2 - 3/4 in. length, #6 or #8 Self-drilling screws | |
| 1/4 in. length, #6 or #8 Self-drilling screws (B-Vent only) | |
| Caulking material (300 °F minimum continuous exposure rating) | |

D. Inspect Appliance and Components

WARNING! Risk of Fire or Explosion! Damaged parts could impair safe operation. **DO NOT** install damaged, incomplete or substitute components. Keep appliance dry.

WARNING! Risk of Fire, Explosion or Electric Shock! **DO NOT** use this appliance if any part has been under water. Call a qualified service technician to inspect the appliance and to replace any part of the control system and/or gas control which has been under water.

- Carefully remove the appliance and components from the packaging.
- The vent system components and decorative barrier fronts may be shipped in separate packages.
- If packaged separately, the log set and appliance grate must be installed.
- Report to your dealer any parts damaged in shipment.
- This product is factory-equipped with an IntelliFire Touch remote control, which was paired to the appliance at the factory. This specific remote control needs to remain with the contents of the manual bag. Do not install batteries in the remote control until performing the final appliance setup and checklist.

Hearth & Home Technologies disclaims any responsibility for, and the warranty will be voided by, the following actions:

- Installation and use of any damaged appliance or vent system component.
- Modification of the appliance or vent system.
- Installation other than as instructed by Hearth & Home Technologies.
- Improper positioning of the logs/media (as applicable) or the glass assembly.
- Installation and/or use of any component part not approved by Hearth & Home Technologies.

3 Framing and Clearances

A. Appliance/Decorative Front Dimension Diagrams

Dimensions are actual appliance dimensions. Use for reference only. For framing dimensions and clearances refer to Section 5.

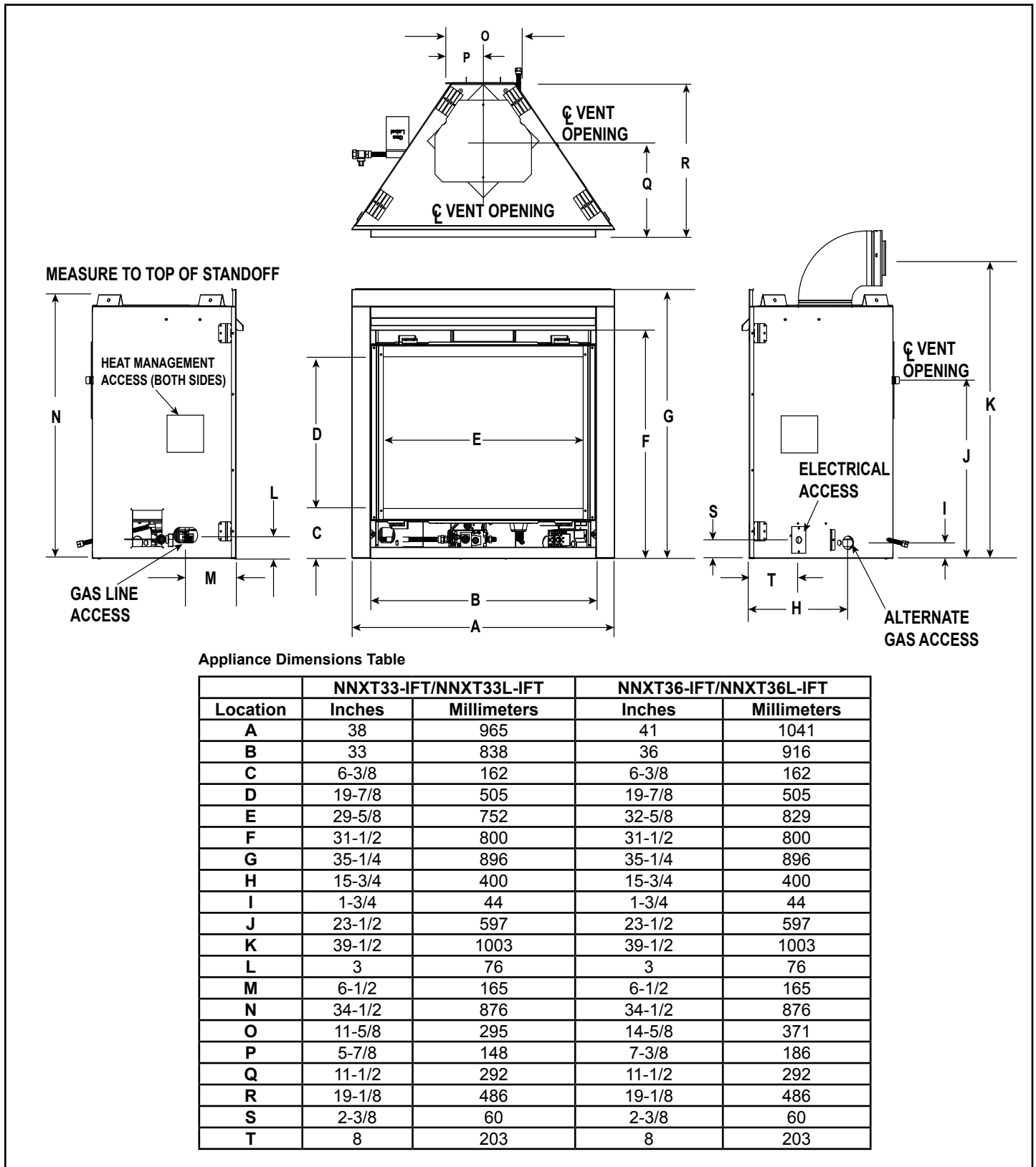

Figure 3.1 Appliance Dimensions - NNXT33-IFT, NNXT33L-IFT, NNXT36-IFT, NNXT36L-IFT

SIMON DECORATIVE BARRIER FRONTS

IMPORTANT! This fireplace requires an installed decorative barrier front to prevent direct contact with the hot viewing glass. **DO NOT** operate the fireplace with the barrier removed.

Decorative barrier front must be ordered at time of fireplace purchase. If decorative barrier front is not present, contact dealer.

Note: See Section 10 for hearth, mantel and finishing requirements.

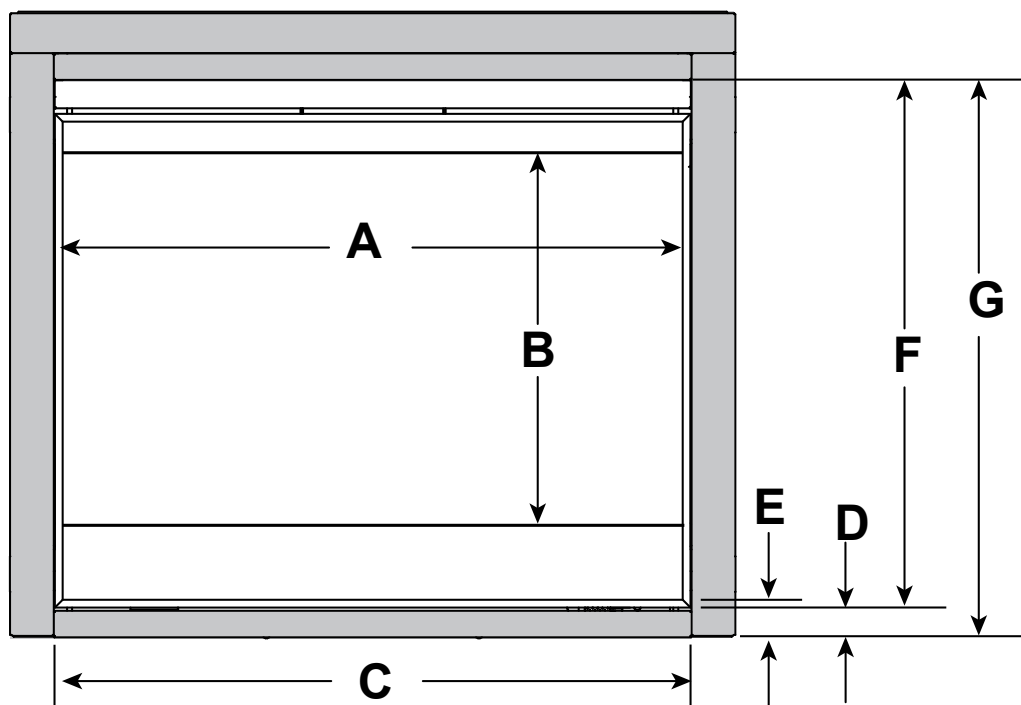

		A	B	C	D	E	F	G
SIM-3933	in.	31-3/8	21	32-7/8	1-5/8	2-3/8	30	31-1/2
	mm	797	533	835	41	60	762	800
SIM-4236	in.	34-3/8	21	35-7/8	1-5/8	2-3/8	30	31-1/2
	mm	873	533	911	41	60	762	800

Figure 3.2 Decorative Barrier Front Dimensions - SIMON-B

B. Appliance Location and Clearances to Combustibles

When selecting a location for the appliance it is important to consider the required clearances to walls and allow sufficient clearance for heat management systems venting. See Figure 3.3 and Figure 3.4.

WARNING! Risk of Fire or Burns! Provide adequate clearance around air openings and for service access. Due to high temperatures, the appliance should be located out of traffic and away from furniture and draperies.

NOTICE: Illustrations reflect typical installations and are FOR DESIGN PURPOSES ONLY. Illustrations/diagrams are not drawn to scale. Actual installation may vary due to individual design preference.

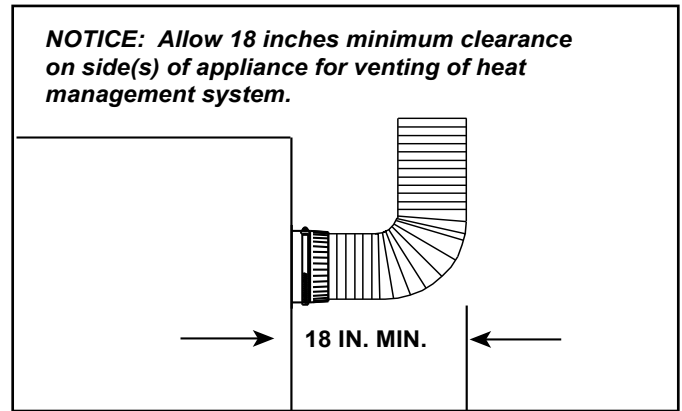

Figure 3.3 Clearance for Heat Management System

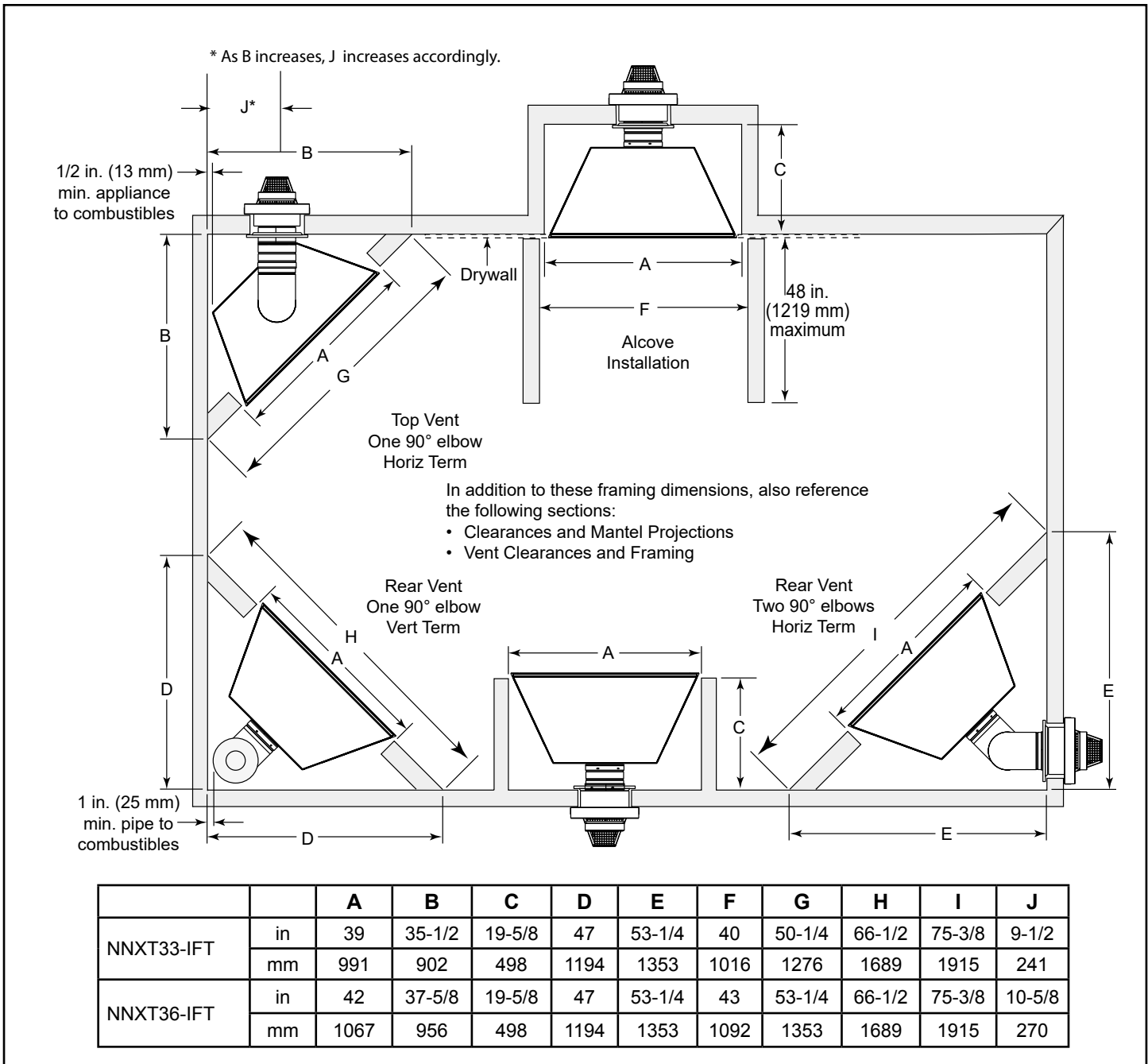
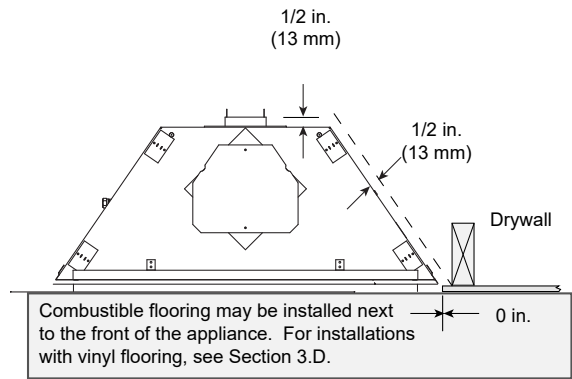

Figure 3.4 Appliance Locations

Note: If the inside of the framed cavity is to be finished, the framing dimensions **must** include the finished surface. If drywall is to be attached to the rear wall, the depth must be measured from the drywall surface.



NO COMBUSTIBLE MATERIALS IN SHADED AREA.

CLEARANCES TO COMBUSTIBLES:
 1 INCH - BOTTOM & SIDES OF VENT PIPE
 3 INCHES- TOP OF VENT PIPE

NO COMBUSTIBLE MATERIALS ALLOWED BELOW TOP OF STANDOFFS.

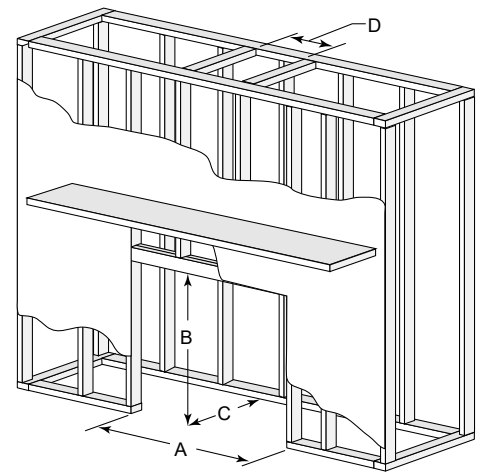
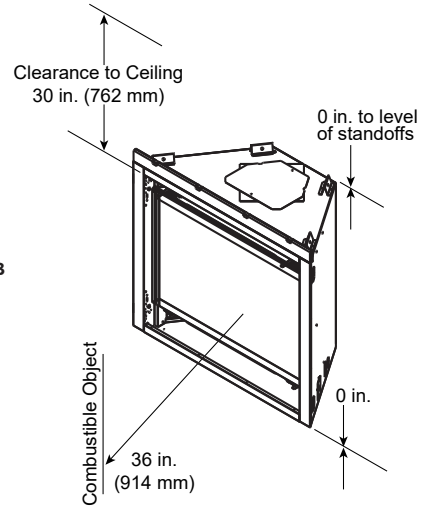
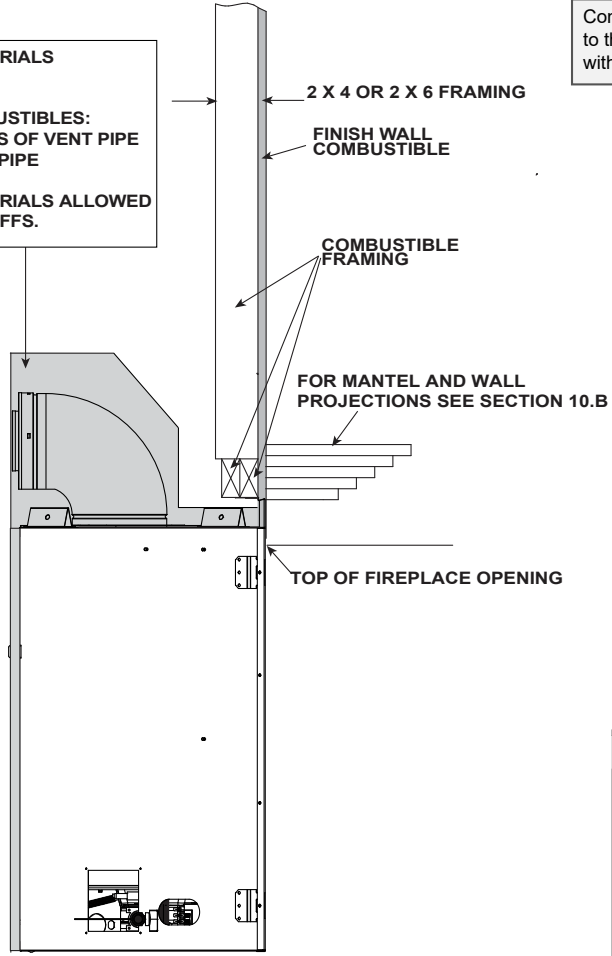

*MINIMUM FRAMING DIMENSIONS						
NNXT MODEL (NG/PROPANE)		A	B	C**	D	D
		Rough Opening (Width)	Rough Opening (Height)	Rough Opening (Depth)	Rough Opening (DVP Pipe)	Rough Opening (SLP Pipe)
NNXT33-IFT	in.	39	34-7/8	19-5/8	10	9
	mm	991	886	498	254	229
NNXT36-IFT	in.	42	34-7/8	19-5/8	10	9
	mm	1067	886	498	254	229

* Adjust framing dimensions for interior sheathing (such as sheetrock)
 C** Add 11-1/2 inches for rear vented elbow vented directly off the rear of the appliance.

Figure 3.5 Clearances to Combustibles

C. Constructing the Appliance Chase

NOTICE: Install appliance on hard metal or wood surfaces extending full width and depth. **DO NOT** install directly on carpeting, vinyl, or any combustible material other than wood.

WARNING! Risk of Fire! Maintain specified air space clearances to appliance and vent pipe:

- Insulation and other materials must be secured to prevent accidental contact.
- The chase must be properly blocked to prevent blown insulation or other combustibles from entering and making contact with fireplace or chimney.
- Failure to maintain airspace may cause overheating and a fire.

A chase is a vertical box-like structure built to enclose the gas appliance and/or its vent system. In cooler climates the vent should be enclosed inside the chase.

NOTICE: Treatment of ceiling firestops and wall shield firestops and construction of the chase may vary with the type of building. These instructions are not substitutes for the requirements of local building codes. Therefore, you **MUST** check local building codes to determine the requirements to these steps.

NOTICE: Where required by code, install only sprinkler heads with a sprinkler activation temperature classified as **Extra High**.

- Sprinklers inside of chase: Keep sprinkler head away from vent and chimney.
- Heat Management applications: Maintain 36 inches of clearance to openings from which heat is discharged such as convection slots, heat zone registers, etc. Refer to Section 6.B for Heat Management options allowed for this appliance.

Chases should be constructed and insulated in the same manner as the thermal envelope of the home based on the code requirements for that climate zone to prevent air leakage and draft problems. The chase is an extension of the building thermal envelope.

To further prevent drafts and air leakage, the wall shield and ceiling firestops should be sealed with caulk with a minimum of 300 °F continuous exposure rating to seal gaps. Gas line holes and other openings should be sealed with caulk with a minimum of 300 °F continuous exposure rating or stuffed with unfaced insulation. If the appliance is being installed on a cement surface, a layer of plywood may be placed underneath to prevent conducting cold up into the room.

Minimum height requirements for an exterior chase on a top-vented appliance are shown in Figure 3.6. Reference Figure 4.4 for additional clearances.

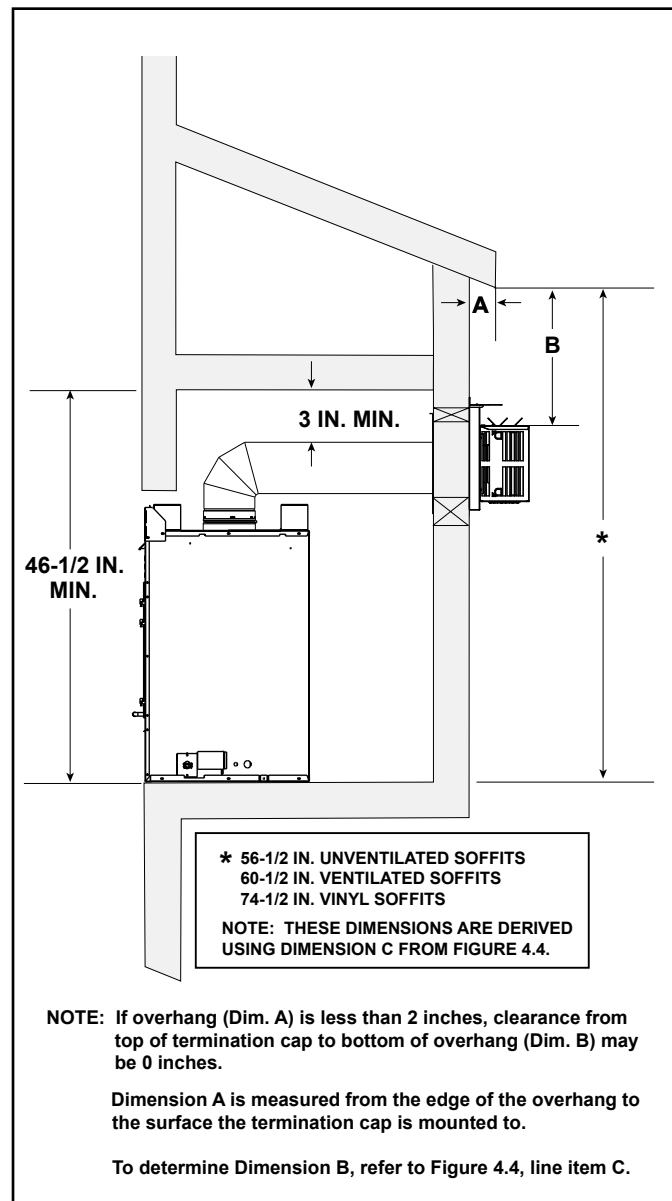

Figure 3.6 Exterior Chase - Minimum Height Requirements

D. Floor Protection

Vinyl Flooring

Vinyl flooring is sensitive to heat. To avoid damage to the vinyl flooring, a 12 inch minimum x 12 inch minimum hearth is recommended when using vinyl flooring up to the wall. See Figure 3.7. If no hearth is used, it is recommended to provide a minimum of 24 inches of clearance in front of the appliance to the vinyl flooring OR the bottom of the appliance should be raised a minimum of 24 inches off of the floor to allow the vinyl flooring to be installed up to the wall.

NOTICE: Clearances that do not meet the minimum guidelines could result in damage or buckling to the vinyl flooring and is done at the installer's or homeowner's risk.

Hearth and Home Technologies does not recommend adhesive based vinyl flooring products due to thermal expansion during operation. Floating style flooring can be used, but it will reach temperatures up to 110 °F (based on ambient temperature of 70 °F). Consult the manufacturer's flooring specifications to ensure compatibility.

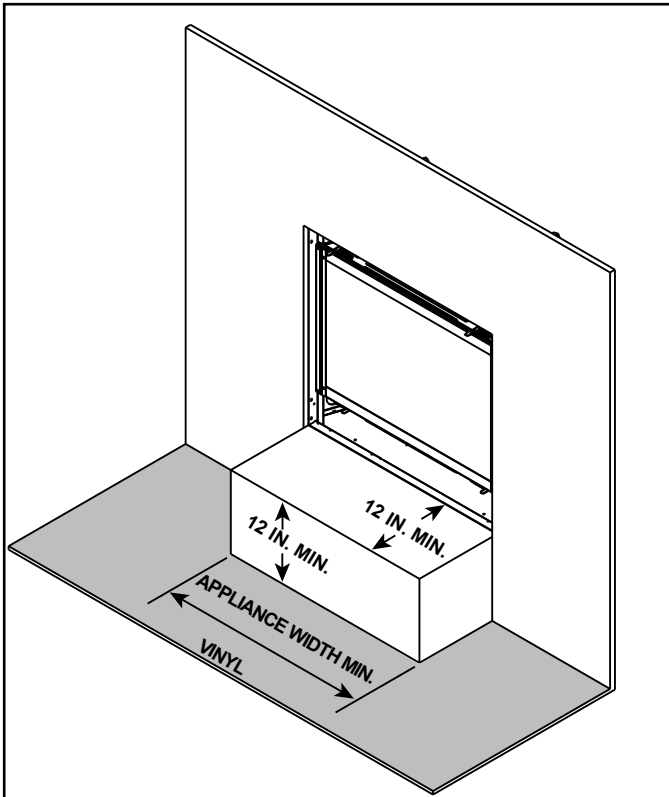

Figure 3.7 Vinyl Flooring Recommendations

4 Termination Location and Vent Information

A. Approved Pipe

WARNING! Risk of Fire, Delayed Ignition or Asphyxiation. This appliance requires a separate vent. **DO NOT** vent to a pipe serving any other appliance.

This appliance is only approved for use with Hearth & Home Technologies DVP or SLP venting systems. Refer to Section 12.A for vent component information and dimensions. Only use listed decorative termination caps/shrouds with Hearth & Home Technologies approved venting systems

DO NOT mix pipe, fittings or joining methods from different manufacturers.

The pipe is tested to be run inside an enclosed wall. There is no requirement for inspection openings at each joint within the wall.

B. Vent Termination Minimum Clearances

⚠ WARNING

Fire Risk.
Maintain vent clearance to combustibles as specified.

- DO NOT** pack air space with insulation or other materials.

Failure to keep insulation or other materials away from vent pipe could cause overheating and fire.

Roof Pitch	H (Min.) Ft
Flat to 6/12.....	1.0*
Over 6/12 to 7/12.....	1.25*
Over 7/12 to 8/12.....	1.5*
Over 8/12 to 9/12.....	2.0*
Over 9/12 to 10/12.....	2.5*
Over 10/12 to 11/12.....	3.25
Over 11/12 to 12/12.....	4.0
Over 12/12 to 14/12.....	5.0
Over 14/12 to 16/12.....	6.0
Over 16/12 to 18/12.....	7.0
Over 18/12 to 20/12.....	7.5
Over 20/12 to 21/12.....	8.0

* H minimum may vary depending on regional snowfall. Refer to local codes.

A	B
6 in. (minimum) up to 20 in. 152 mm/508 mm	18 in. minimum 457 mm
20 in. and over	0 in. minimum

* If using decorative cap cover(s), this distance may need to be increased. Refer to the installation instructions supplied with the decorative cap cover.

** If two gas terminations are present, they may be level (B = 0 inches) provided A is a minimum of 6 inches.

Figure 4.2 Staggered Termination Caps

CAUTION! Risk of Burns! Termination caps are **HOT**, consider proximity to doors, traffic areas or where people may pass or gather (sidewalk, deck, patio, etc.). Listed cap shields available. Contact your dealer.

- Local codes or regulations may require different clearances.
- Hearth & Home Technologies assumes no responsibility for the improper performance of the appliance when the venting system does not meet these requirements.
- Vinyl protection kits are suggested for use with vinyl siding.
- Measure horizontal and vertical termination cap clearances as noted in Figure 4.3.

Figure 4.3

C. Vent Terminal Clearances

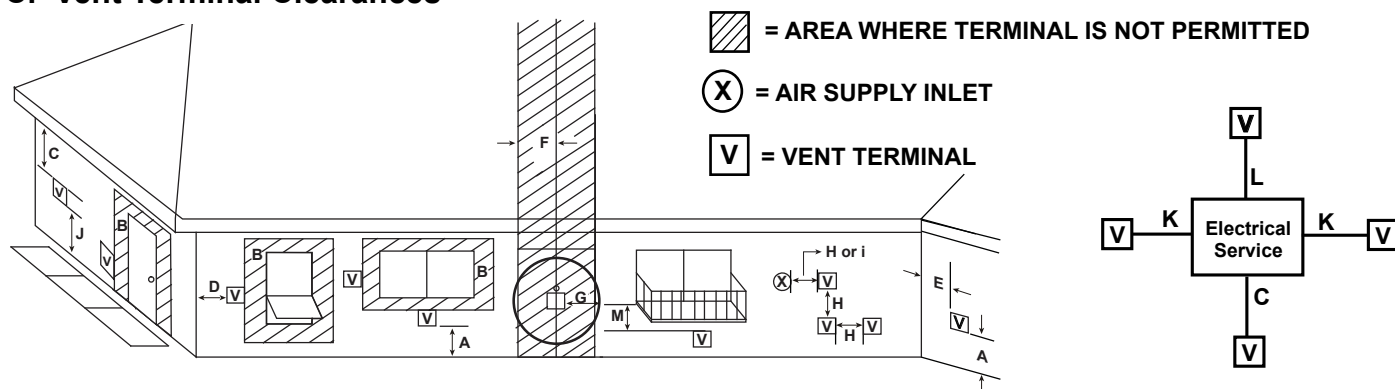

U.S.A. Installations: In accordance with the current ANSI Z223.1/NFPA 54, National Fuel Gas Code.

Canadian Installations: In accordance with the current CSA B149.1, Natural Gas and Propane Installation Code.

		U.S.A.	CANADA
A	Clearance above grade, veranda, porch, deck, or balcony	12 in. (305 mm)	12 in. (305 mm)
B	Clearance to window or door that may be opened, or to permanently closed window	9 in. (229 mm)	12 in. (305 mm)
C	clearance below unventilated soffit	12 in. (305 mm)	12 in. (305 mm)
	clearance below ventilated soffit	18 in. (457 mm)	18 in. (457 mm)
	clearance below any vinyl soffits and electrical service	30 in. (762 mm)	30 in. (762 mm)
D	clearance to outside corner	6 in. (152 mm)	6 in. (152 mm)
E	clearance to inside corner	6 in. (152 mm)	6 in. (152 mm)
F	not to be installed above a gas meter/regulator assembly within 3 feet horizontally from the center-line of the regulator	3 ft (914 mm)	3 ft (914 mm)
G	clearance to gas service regulator vent outlet	3 ft (914 mm)	3 ft (914 mm)
H	clearance to non-mechanical air supply inlet to building or the combustion air inlet to any other appliance termination (mechanical or non-mechanical)	9 in. (228 mm)	12 in. (305 mm)
I	clearance to a mechanical (powered) air supply inlet *** (All mechanical air intakes within 10 feet of a horizontal termination cap must be a minimum of 3 feet below termination.)	3 ft (914 mm)***	6 ft (1.8 m)
J	On public property: clearance above paved sidewalk or a paved driveway.	7 ft (2.1 m)	7 ft (2.1 m)**
	**(A vent shall not terminate directly above a sidewalk or paved driveway which is located between two single family dwellings and serves both dwellings.)		
K	clearance from sides of electrical service	6 in. (152 mm)	6 in. (152 mm)
	Location of the vent termination must not interfere with access to the electrical service.		
L	clearance above electrical service	12 in. (305 mm)	12 in. (305 mm)
	Location of the vent termination must not interfere with access to the electrical service.		
M	clearance under veranda, porch, deck, balcony or overhang *(Permitted only if veranda, porch, deck, or balcony is fully open on a minimum of two sides beneath the floor.)	12 in. (305 mm)	12 in. (305 mm)*
	vinyl or composite overhang	30 in. (762 mm)	30 in. (762 mm)

Figure 4.4 Minimum Clearances for Termination

D. Use of Elbows

Diagonal runs have both vertical and horizontal vent aspects when calculating the effects. Use the rise for the vertical aspect and the run for the horizontal aspect. See Figure 4.5.

Two 45° elbows may be used in place of one 90° elbow. On 45° runs, one foot of diagonal is equal to 8-1/2 in. (216 mm) horizontal run and 8-1/2 in. (216 mm) vertical run. A length of straight pipe is allowed between two 45° elbows. See Figure 4.5.

Figure 4.6 shows the vertical and horizontal offsets for DVP or SLP elbows.

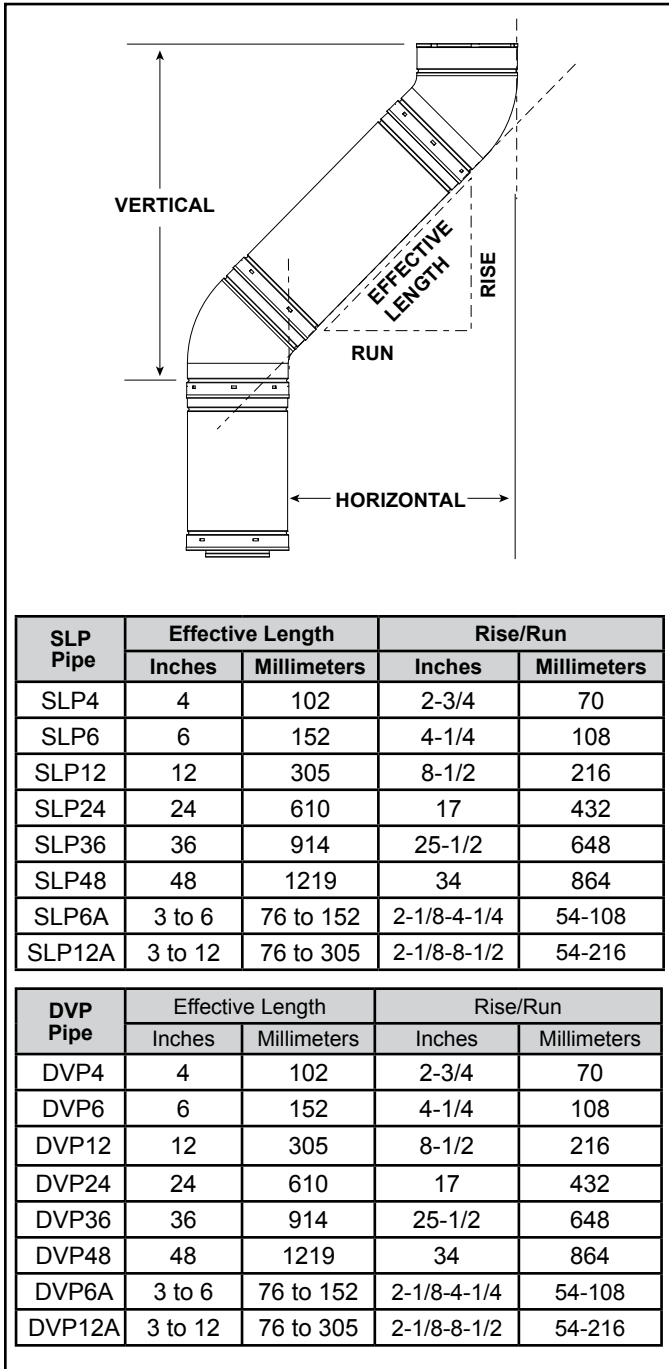

Figure 4.5

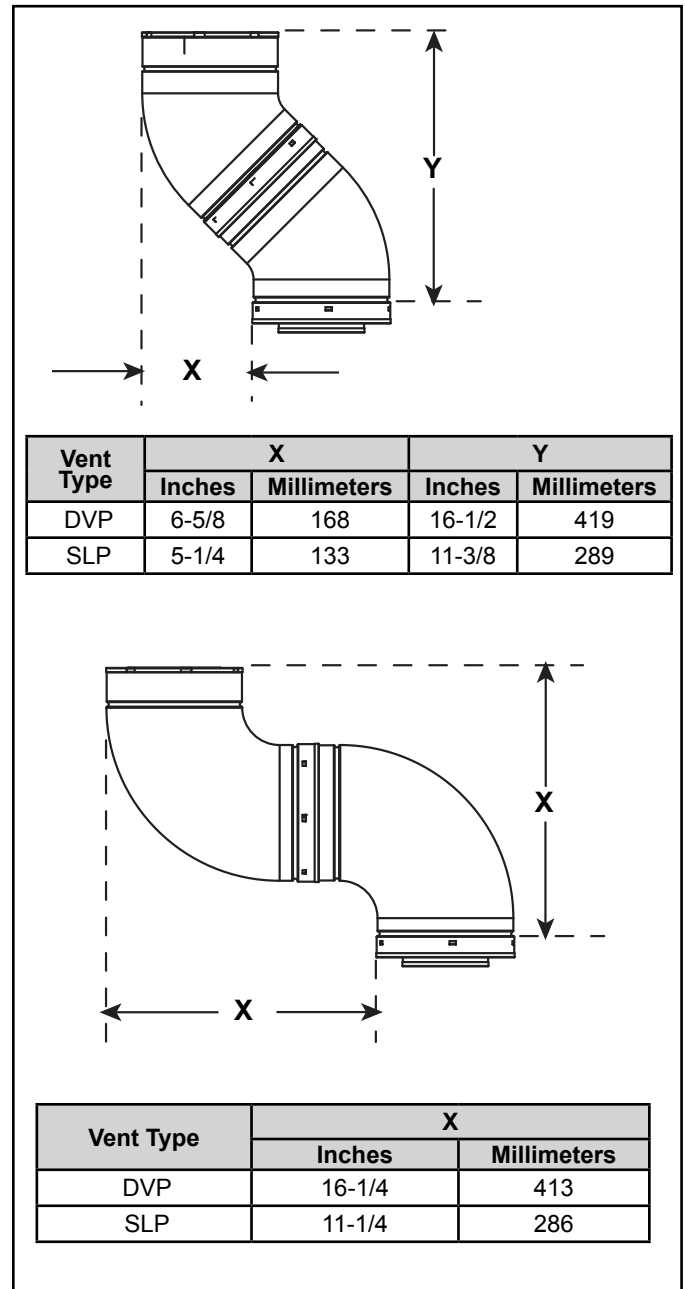

Figure 4.6 Vertical and Horizontal Offset for DVP and SLP Elbows

Note: Back to back 45 degree or 90 degree elbows have no additional vertical or horizontal value and are not included in determining maximum vent run lengths.

E. Vent Diagrams

General Rules:

- A maximum of three 90° elbows (or six 45° elbows) may be used in any vent configuration. Some elbows may be installed horizontally. See Figure 4.15.
- A maximum of three 90° elbows (or six 45° elbows) may be used in a top vented, vertically terminated vent configuration. See Figure 4.24.
- Elbows may be placed back to back anywhere in the system.
- Any 90° elbow may be replaced with two back to back 45° elbows.
- When penetrating a combustible wall, a wall shield firestop must be installed.
- When penetrating a combustible ceiling, a ceiling firestop must be installed.
- Horizontal runs of vent do not require vertical rise; horizontal runs may be level.
- When the horizontal termination cap is exposed to high precipitation, the cap should have a 1/4 inch downward slant to allow any moisture in cap to be released. See Figure 4.7. See Figure 4.8 for additional water infiltration prevention.

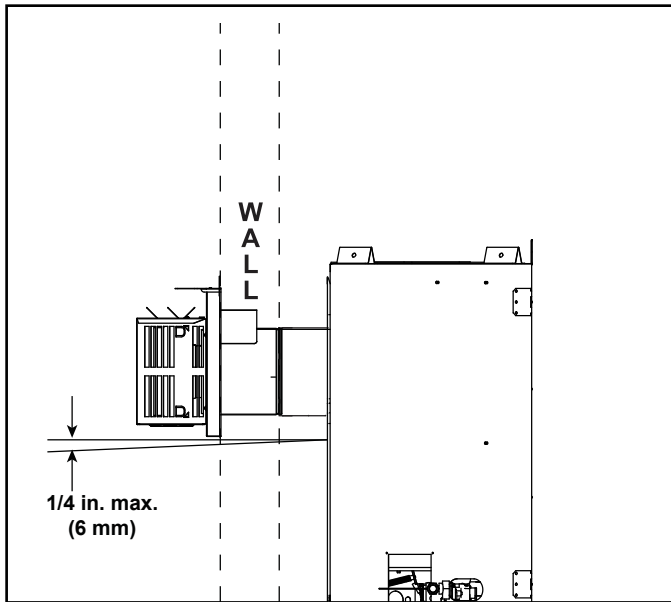

→ Figure 4.7 Water Infiltration Prevention

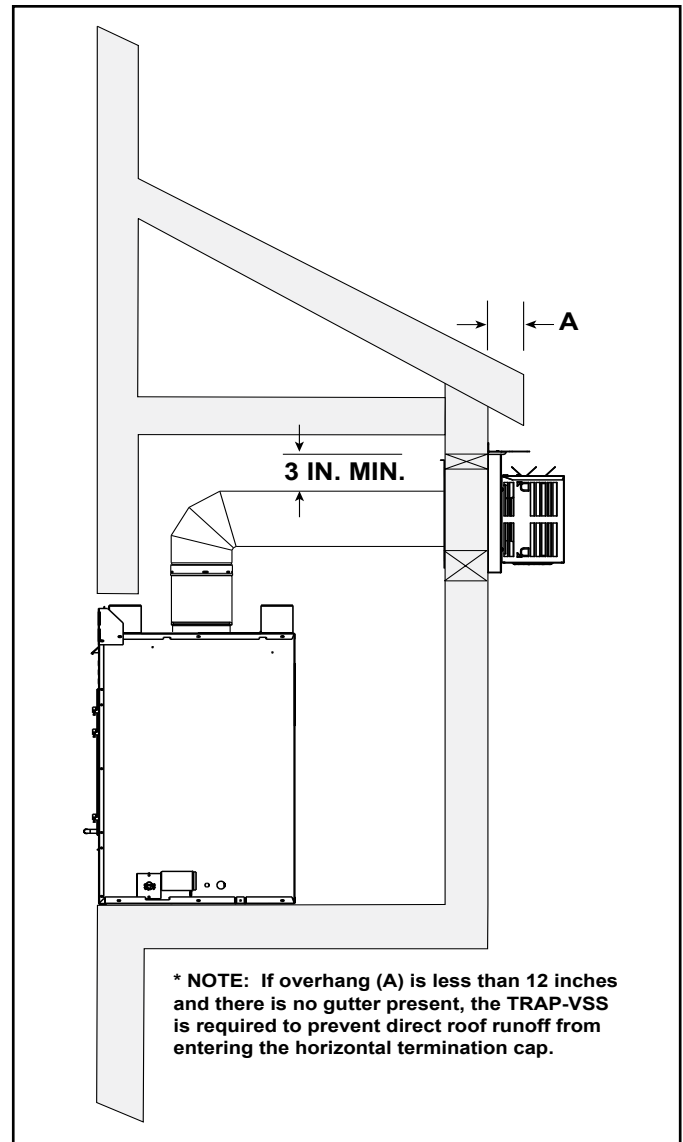
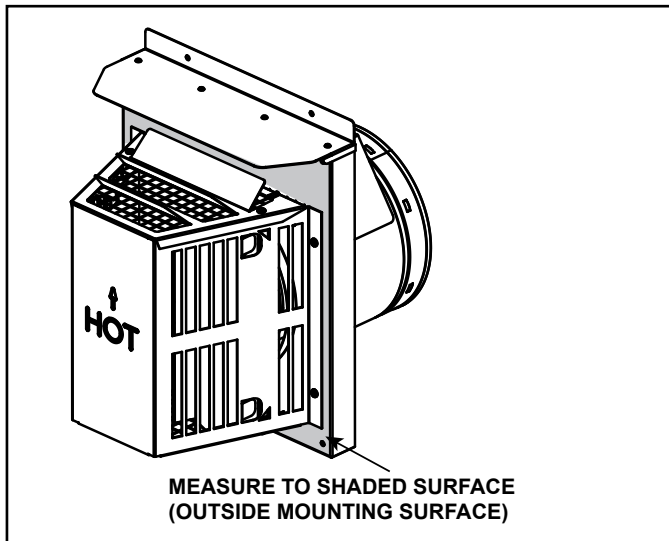

Figure 4.8 Exterior Chase - Water Infiltration Prevention ←

Measuring Standards

Vertical and horizontal measurements listed in the vent diagrams were made using the following standards:

- Pipe measurements are shown using the effective length of pipe. See Section 12.A (Figure 12.1 for DVP, Figure 12.7 for SLP) for information on effective length of pipe components.
- Horizontal terminations are measured to the outside mounting surface (flange of termination cap) (see Figure 4.9).
- Vertical terminations are measured to top of last section of pipe. See Figure 4.10.
- Horizontal pipe installed level with no rise.



→ Figure 4.9 Measure to Outside Mounting Surface

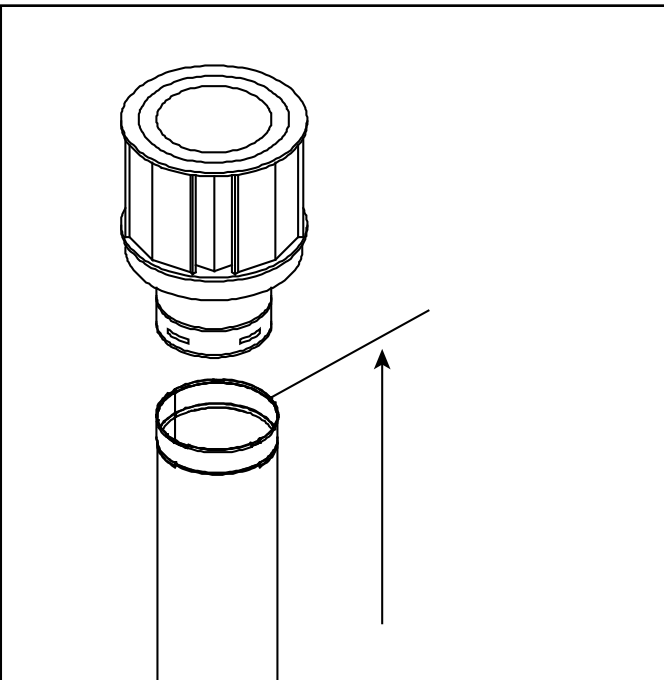

Figure 4.10 Measure to Top of Last Section of Pipe

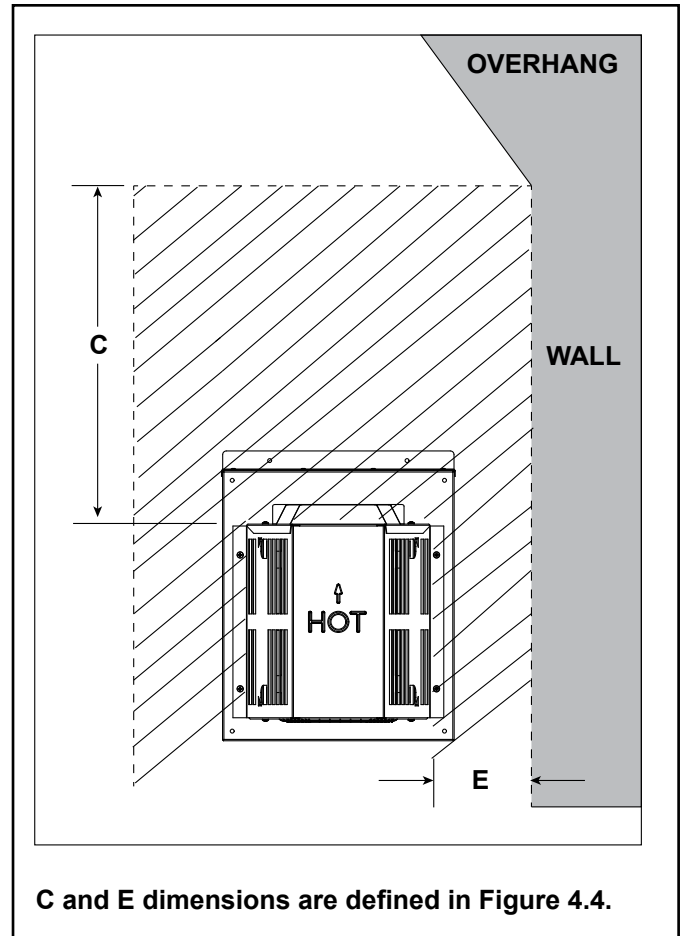

Figure 4.11 Measure Horizontal and Vertical Termination Clearance to Trapezoid Portion of Cap ←

Note: The Novus series appliances can adapt to SLP series vent pipe when venting off the top of the appliance. You must use a DVP-SLP24 adapter or a DVP-2SL and two feet of SLP pipe which can only be attached to the appliance starting collar.

When looking at horizontal termination diagrams, neither adapter is counted as part of the minimum vertical (V_1 min.) requirements.

All venting rules for the vent run must still be followed.

Top Vent - Horizontal Termination

Top Vent—Horizontal Termination—Two 45° Elbows
 Installation requirements to replace the first 90° elbow with two 45° elbows:

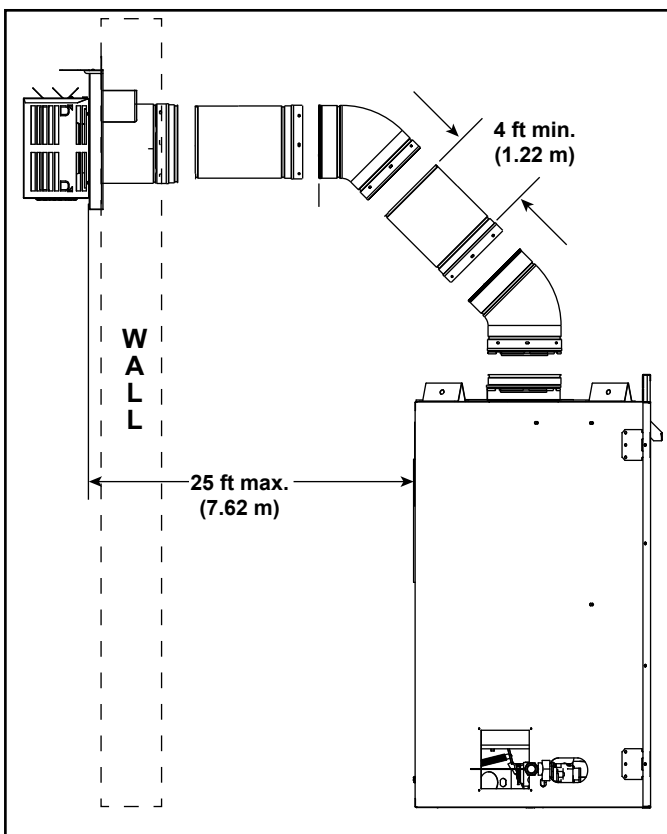

→ Figure 4.12 Minimum Installation Requirements for Two 45 Degree Elbows - Top Vent - Horizontal Termination

HORIZONTAL EXAMPLE (IDENTICAL VENT RUNS USING DVP AND SLP PIPE)

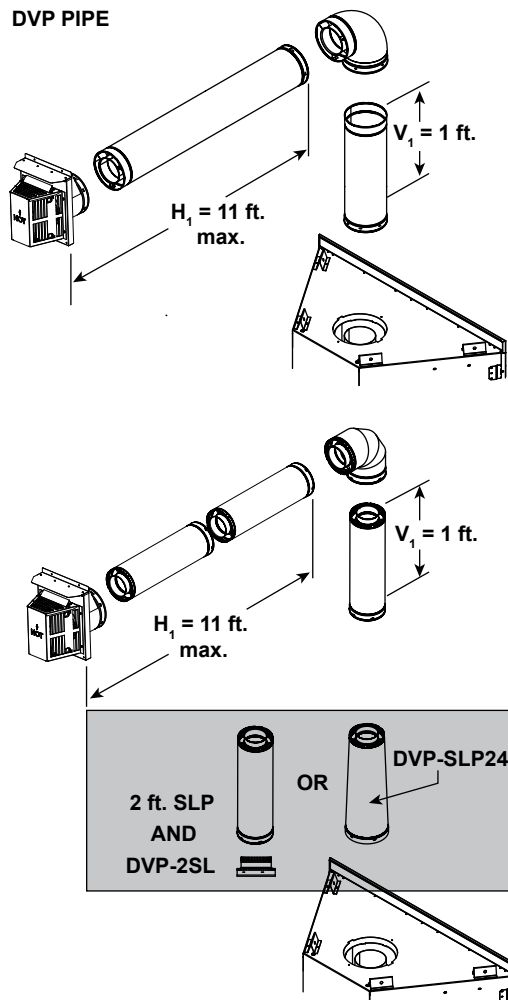

VERTICAL EXAMPLE (IDENTICAL VENT RUNS USING DVP AND SLP PIPE)

*Minimum vertical dimension includes vertically oriented 45 degree elbows.

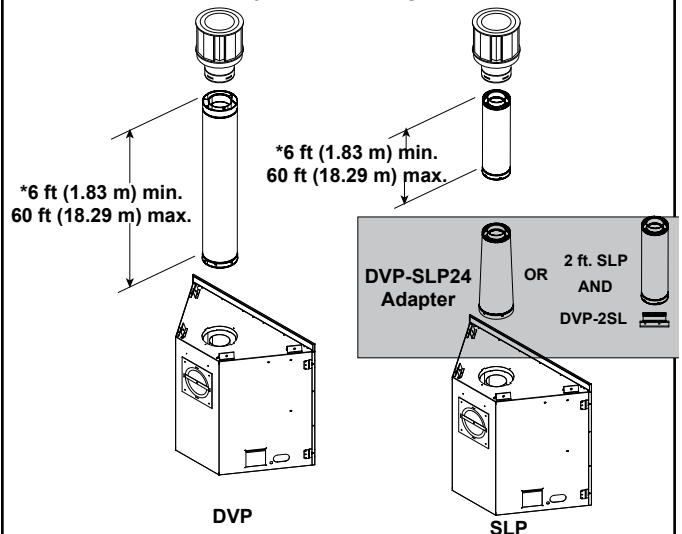
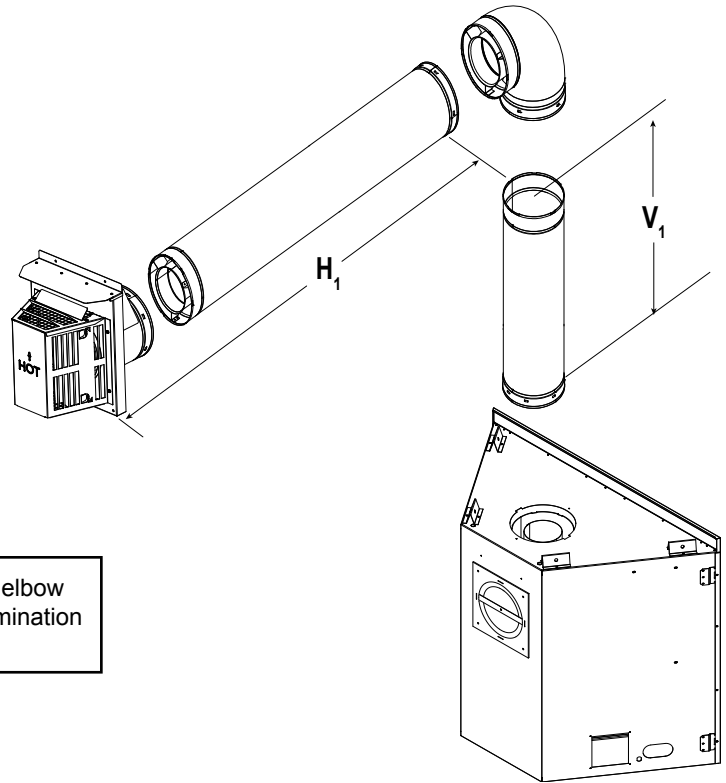

Figure 4.13

Top Vent - Horizontal Termination One Elbow

V_1 Minimum		H_1 Maximum	
0*	0*	18 in.	457 mm
4 in.	102 mm	4 ft.	1.22 m
6 in.	152 mm	6 ft.	1.83 m
12 in.	305 mm	11 ft.	3.35 m
18 in.	457 mm	17 ft.	5.2 m
24 in.	610 mm	17 ft.	5.2 m
$V_1 + H_1 = 50$ ft. (15.24 m) Maximum			
* You may install the elbow directly on top of the appliance (DVP only).			



NOTE: A minimum venting scenario consists of a 90 degree elbow off the top of the appliance with a DVP-TRAP2 horizontal termination cap.

→ Figure 4.14

Two or Three Elbows Installed Horizontally

V_1 Minimum		$H_1 + H_2$ Maximum		$H_1 + H_2 + H_3$ Maximum	
6 in.	152 mm	6 ft.	1.83 m	-	-
12 in.	305 mm	11 ft.	3.4 m	8 ft.	2.4 m
18 in.	457 mm	17 ft.	5.2 m	14 ft.	4.3 m
24 in.	610 mm	17 ft.	5.2 m	14 ft.	4.3 m
$V_1 + H_1 + H_2 = 50$ ft. (15.24 m) Maximum					
$V_1 + H_1 + H_2 + H_3 = 47$ ft. (14.33 m) Maximum					

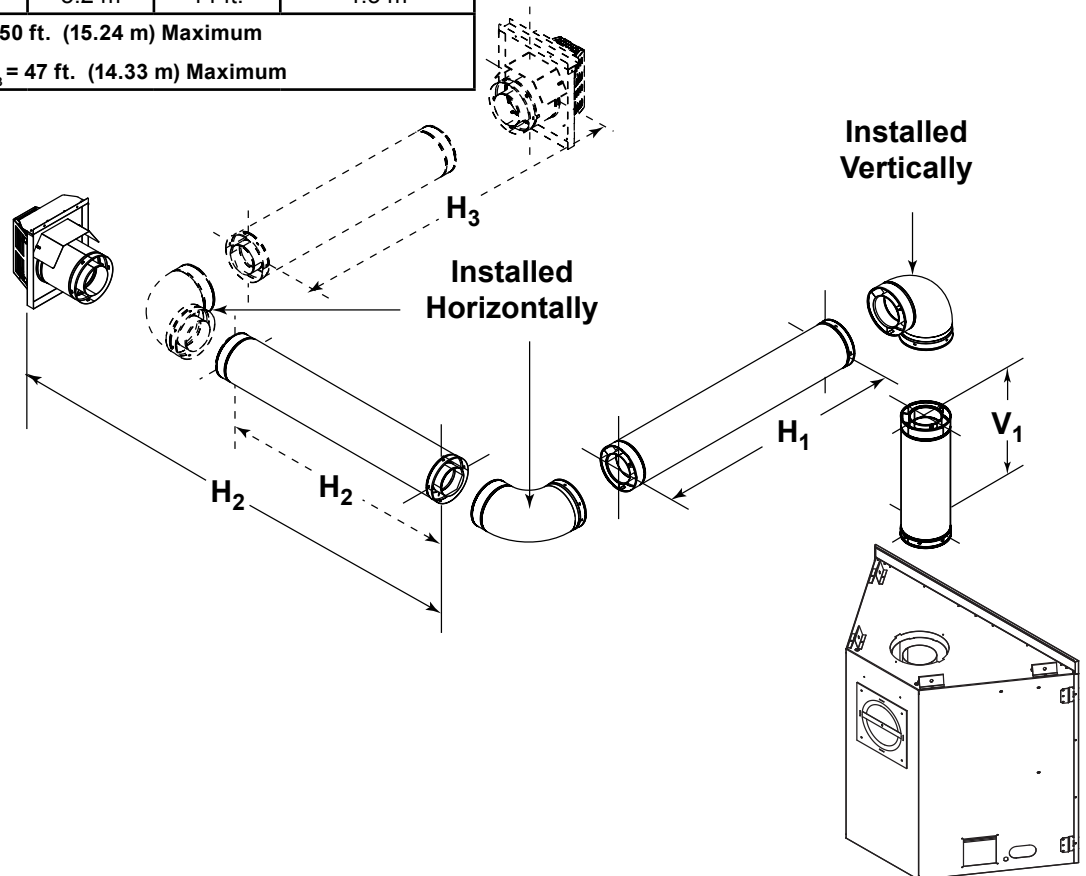
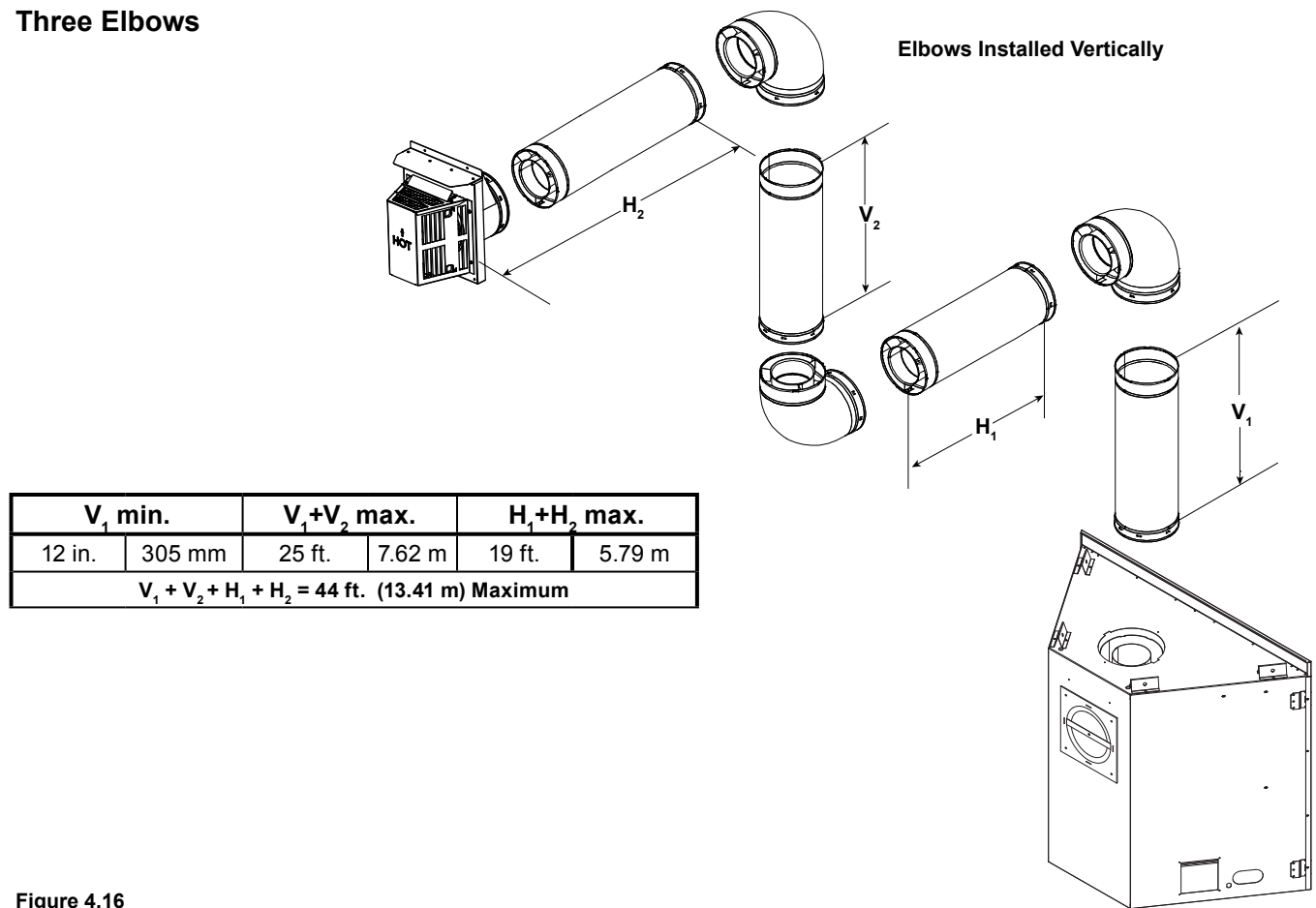

Figure 4.15

Top Vent - Horizontal Termination - (continued)

Three Elbows



→ Figure 4.16

Top Vent - Vertical Termination

No Elbow

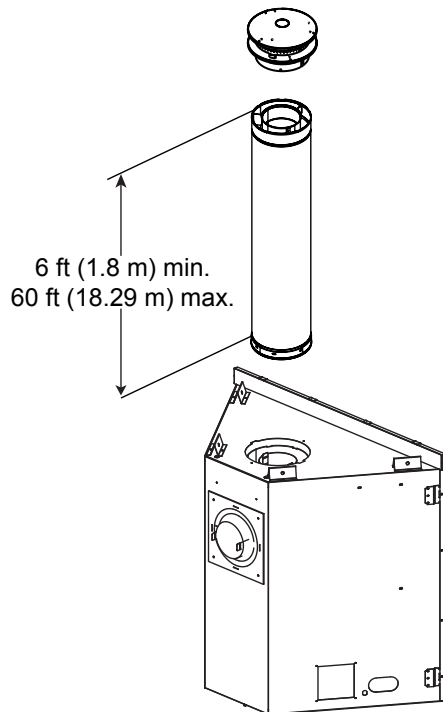

Figure 4.17

Install Top Vent Flue Visor - No Elbow Configurations

- Remove the refractory retainer from one of the side refractories.

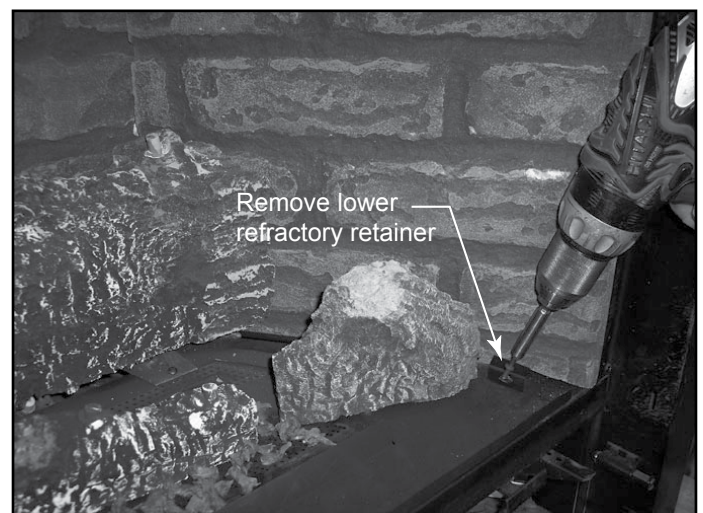

Figure 4.18 Remove Refractory Retainer

- Remove the side refractory:
 - Gently raise the front of the top refractory.
 - Lift the side piece up slightly and then out.

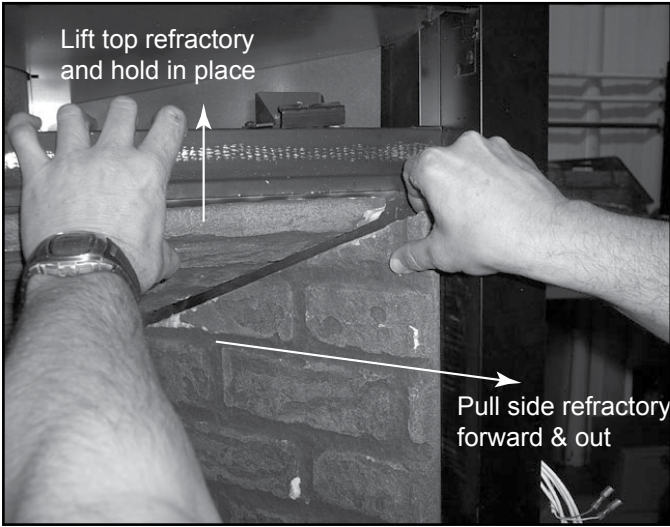

Figure 4.19 Remove Side Refractory

- Remove top refractory:
 - Lower towards side removed in previous step.
 - Gently twist out.

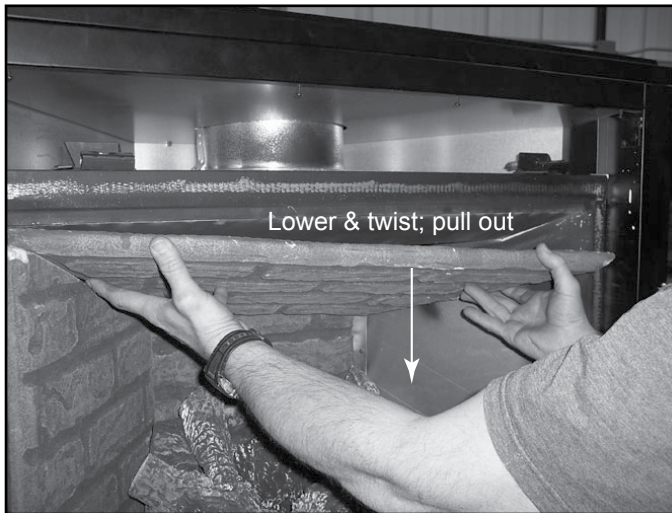

Figure 4.20 Remove Top Refractory

- Remove two screws from firebox top.
- Using these screws and the same holes, install the top vent flue baffle.
 - The flue baffle will be turned to install below the level of the firebox top for 12-30 ft. vertical runs of vent. See Figure 4.21.
 - The flue baffle will be turned to install inside the flue for vertical vent runs of 31-60 ft. See Figure 4.22.

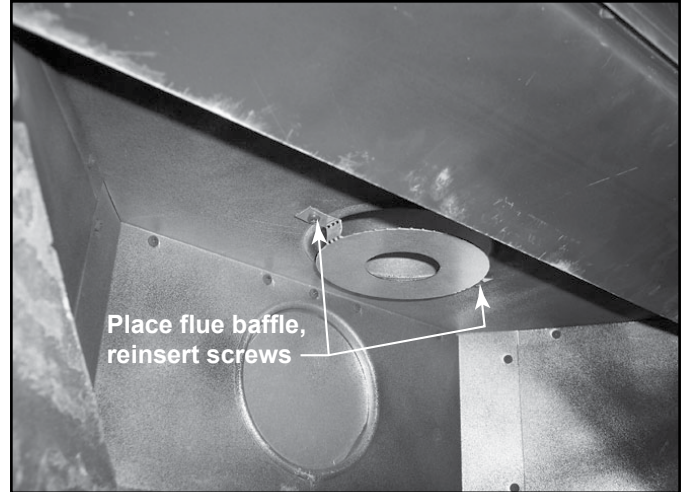

Figure 4.21 12-30 Foot Vertical Run

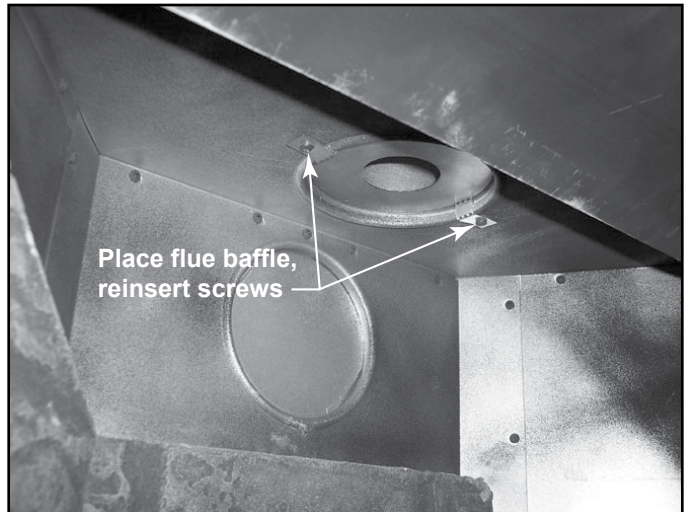

Figure 4.22 31-60 Foot Vertical Run

- Reinstall Refractory:
 - Replace top refractory.
 - Lift top refractory and slide side refractory back into position.
 - Replace bottom retainer.

Top Vent - Vertical Termination - (continued)

Two Elbows

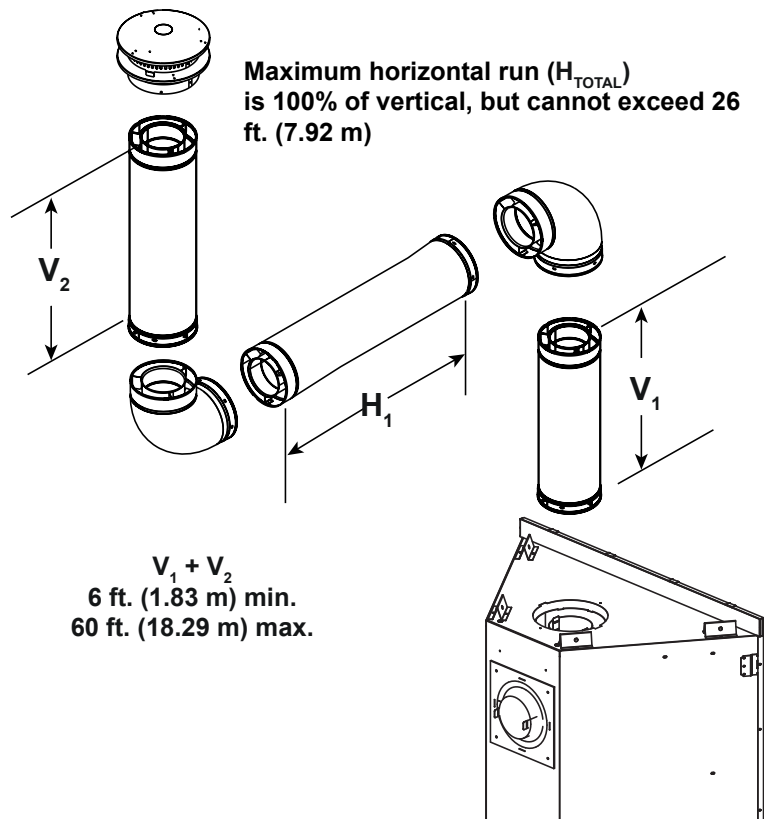

Figure 4.23

Three Elbows

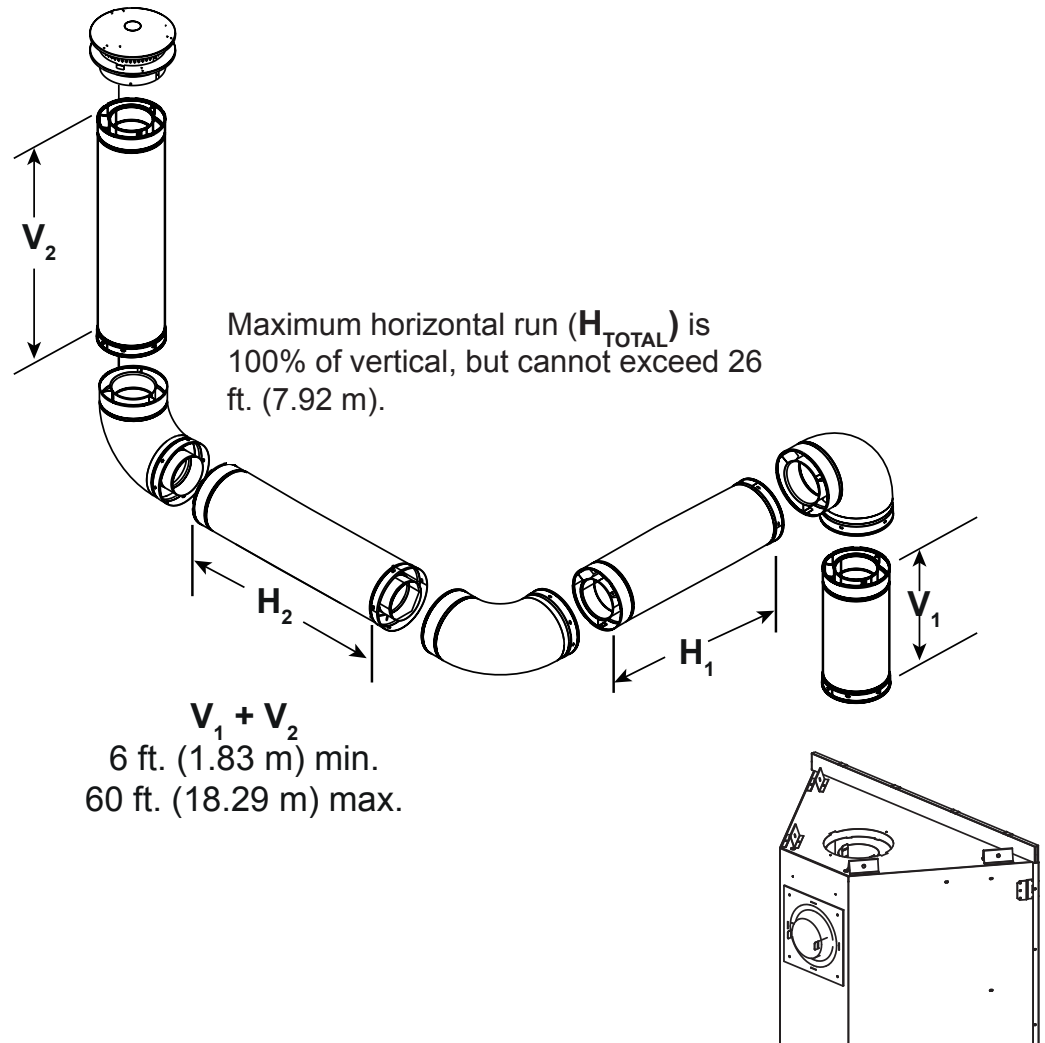
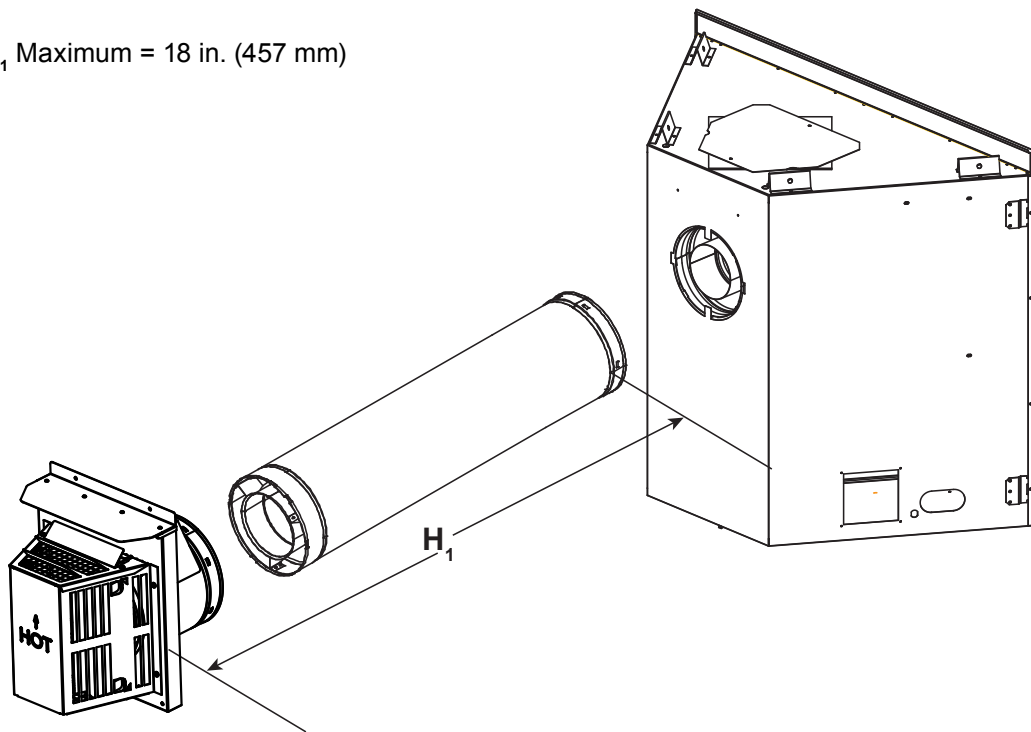

Figure 4.24

Rear Vent - Horizontal Termination

No Elbow

H_1 Maximum = 18 in. (457 mm)



→ Figure 4.25

Two Elbows

V_1 min.		H_1 max.		H_{Total}	
<i>ft</i>	<i>m</i>	<i>ft</i>	<i>m</i>	<i>ft</i>	<i>m</i>
0	0	1	0.30	3	0.91
2	0.61	1	0.30	3	0.91
4	1.22	2	0.61	6	1.83
6	1.83	3	0.91	9	2.74
8	2.44	4	1.22	12	3.66
8	2.44	5	1.52	15	4.57
8	2.44	6	1.83	18	5.49

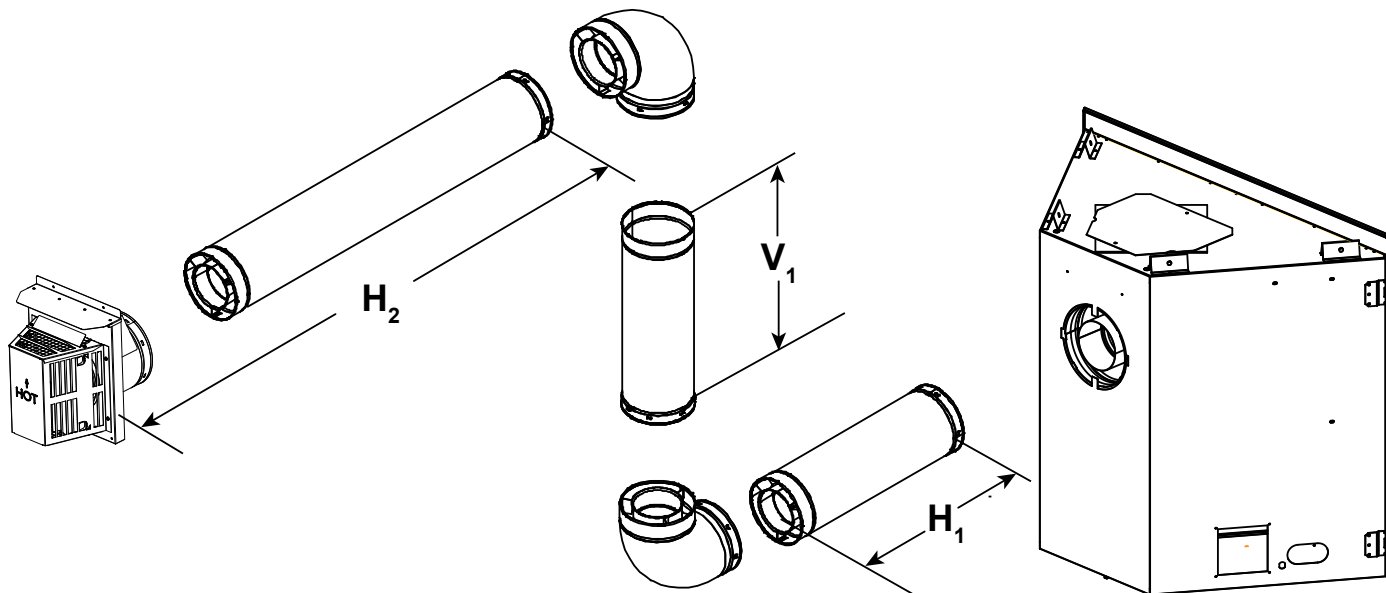

→ Figure 4.26

Rear Vent - Horizontal Termination - (continued)

Three Elbows

V_1 min.		H_1 max.		H_{Total}	
<i>ft</i>	<i>m</i>	<i>ft</i>	<i>m</i>	<i>ft</i>	<i>m</i>
0	0	1	0.30	3	0.91
2	0.61	1	0.30	3	0.91
4	1.22	2	0.61	6	1.83
6	1.83	3	0.91	9	2.74
8	2.44	4	1.22	12	3.66
8	2.44	5	1.52	15	4.57
8	2.44	6	1.83	18	5.49

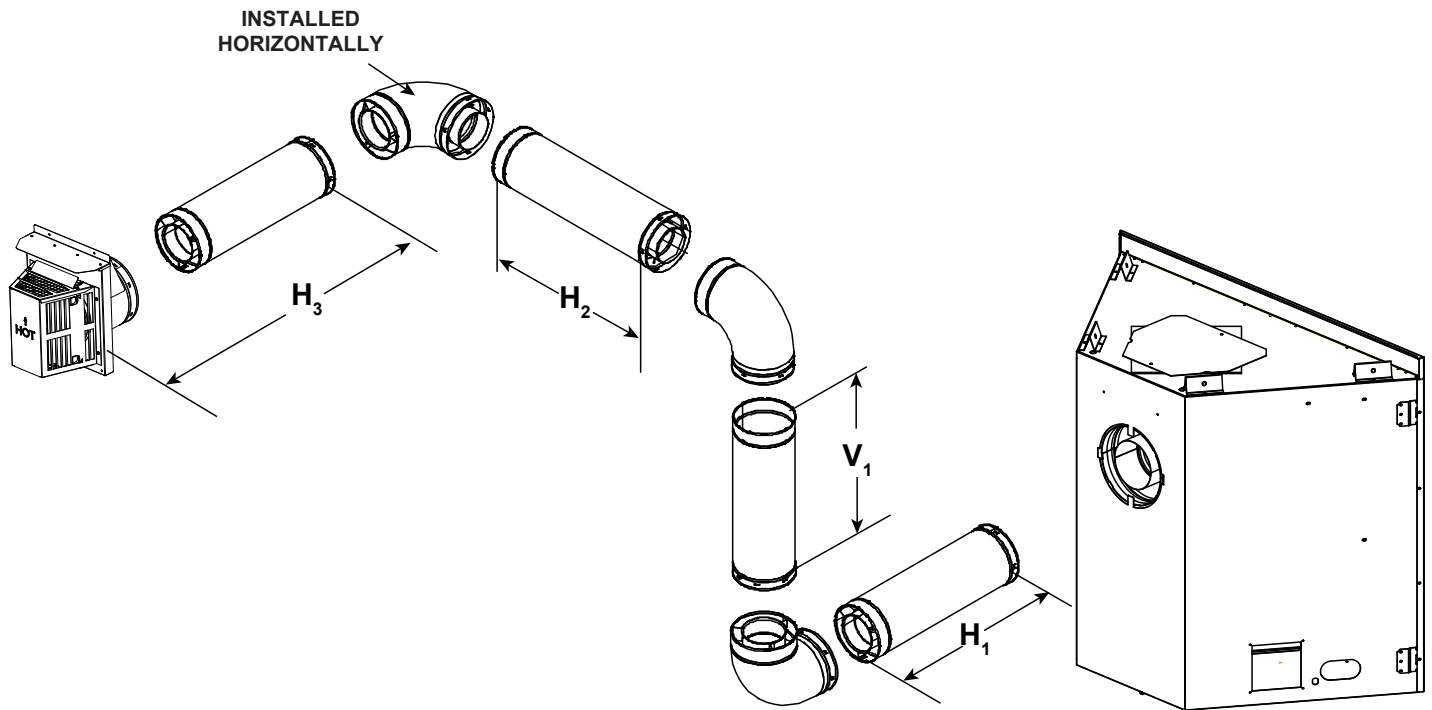

→ Figure 4.27

Rear Vent - Vertical Termination

One Elbow

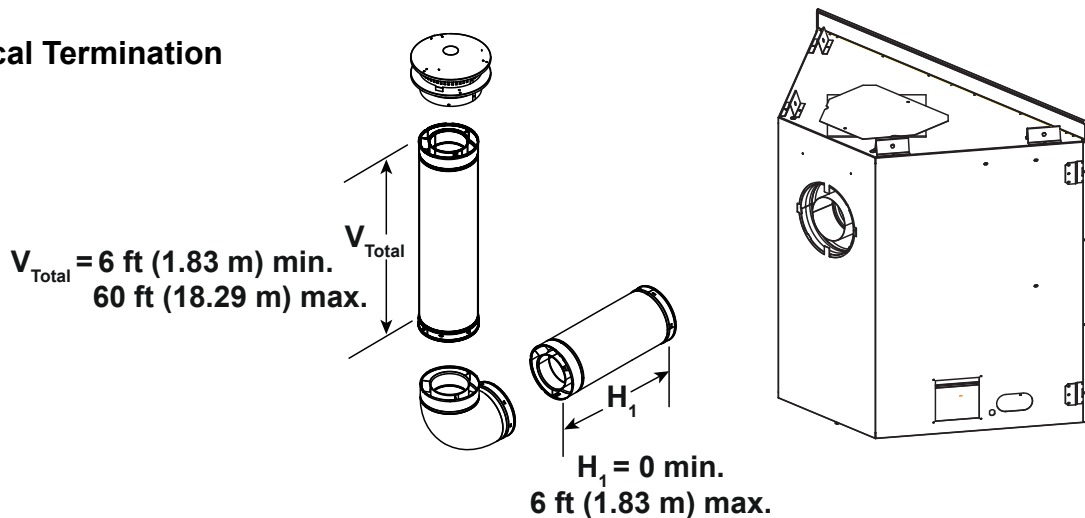

Figure 4.28

Two Elbows

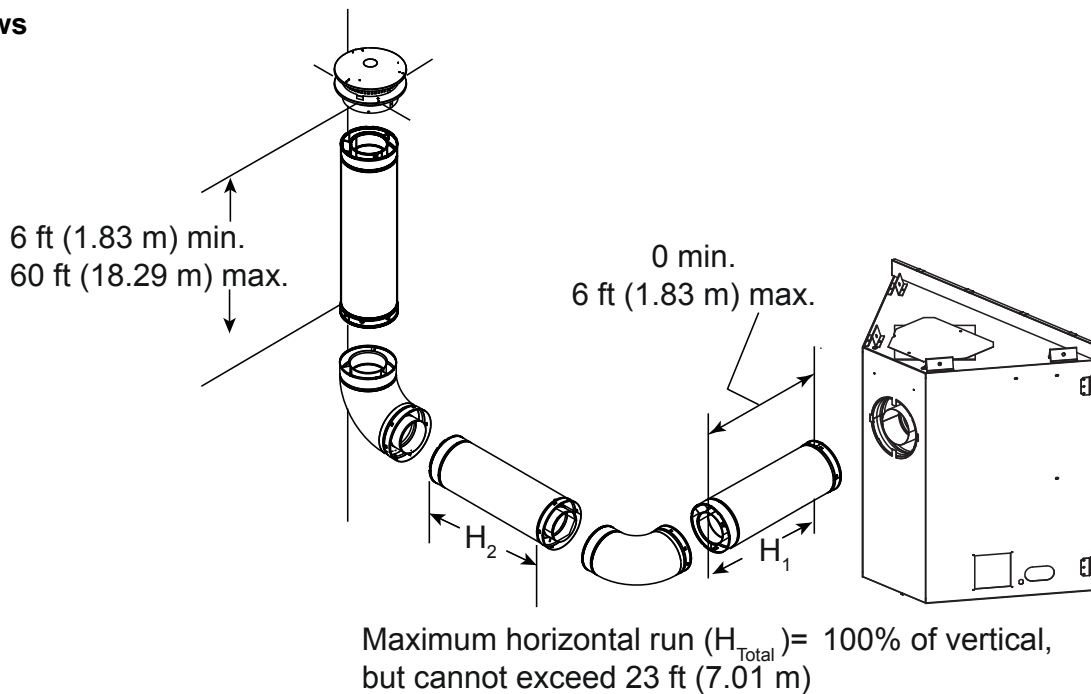

Figure 4.29

Three Elbows

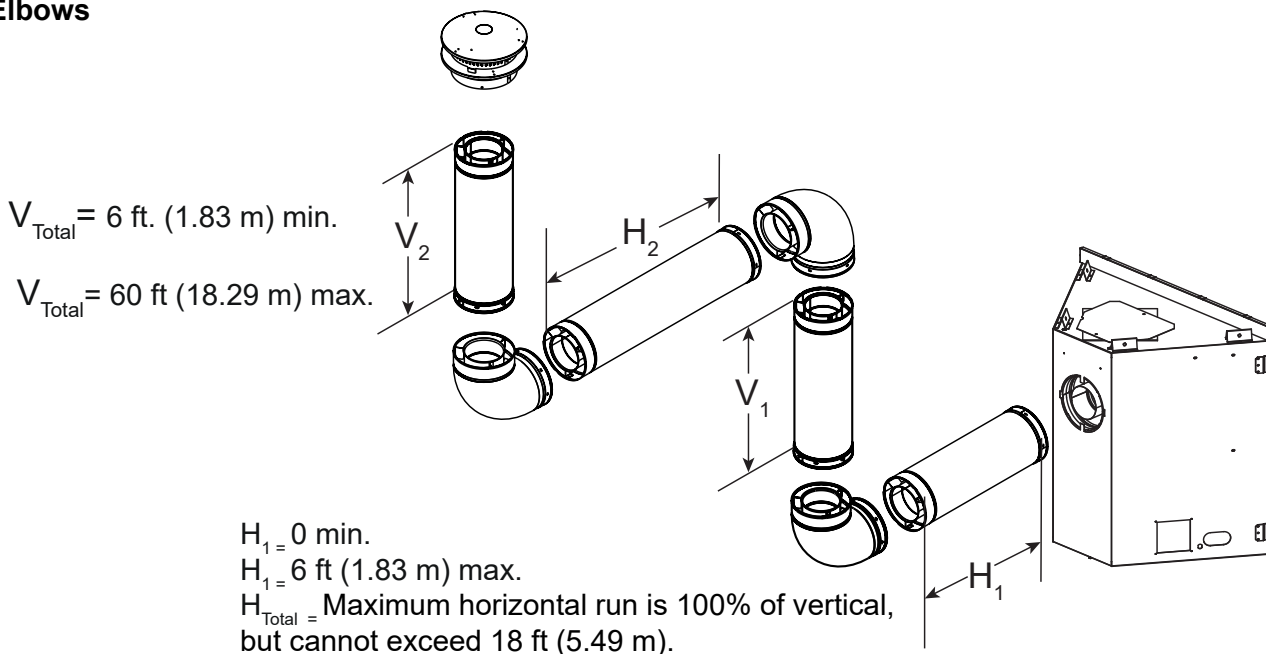

Figure 4.30

5 Vent Clearances and Framing

A. Pipe Clearances to Combustibles

WARNING! Risk of Fire! Maintain air space clearance to vent. DO NOT pack insulation or other combustibles:

- Between ceiling firestops
- Between wall shield firestops
- Around vent system

Failure to keep insulation or other material away from vent pipe could cause overheating and fire.

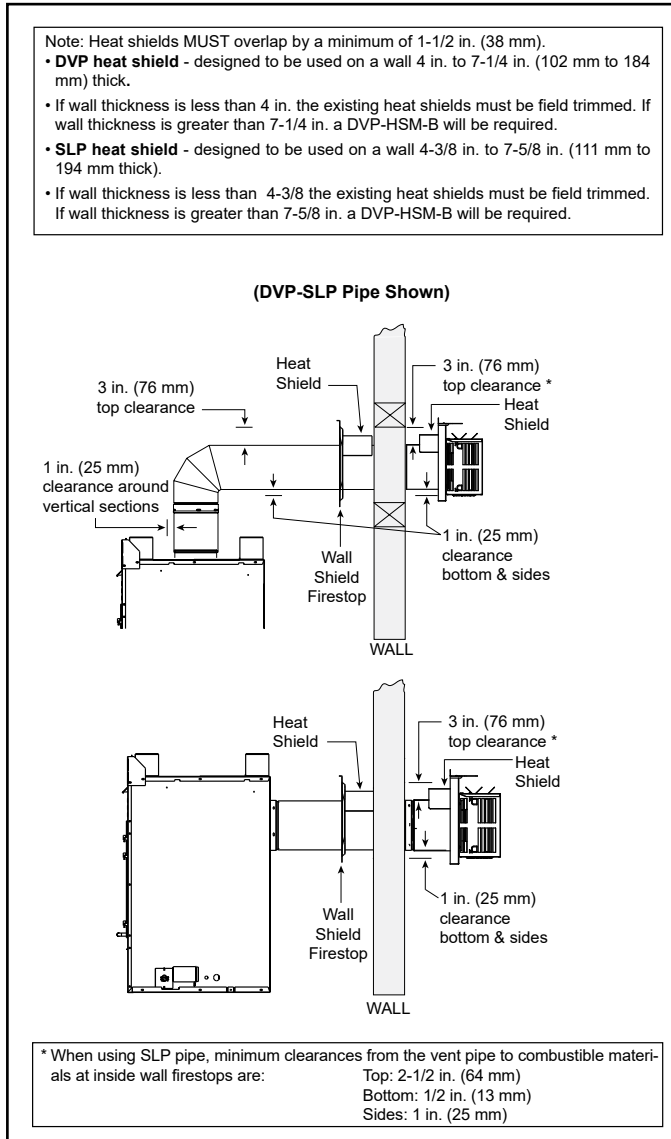

→ Figure 5.1 Horizontal Venting Clearances To Combustible Materials

B. Wall Penetration Framing/Firestops

Combustible Wall Penetration

Whenever a combustible wall is penetrated, you must frame a hole for the wall shield firestop(s). The wall shield firestop maintains minimum clearances and prevents cold air infiltration.

- The opening must be framed on all four sides using the same size framing materials as those used in the wall construction.
- SLP pipe - A wall shield firestop must be placed on each side of an interior wall. A minimum 1-1/2 in. (38 mm) overlap of attached heat shields must be maintained.
- DVP pipe - A wall shield firestop is required on one side only on interior walls. If your local inspector requires a wall shield firestop on both sides, then both wall shield firestops must have a heat shield (refer to Section 12.A.) attached to them.
- See Section 7.F. for information for regarding the installation of a horizontal termination cap.

Non-Combustible Wall Penetration

If the hole being penetrated is surrounded by non-combustible materials such as concrete, a hole with diameter one inch greater than the pipe is acceptable.

Whenever a non-combustible wall is penetrated, the wall shield firestop is only required on one side and no heat shield is necessary.

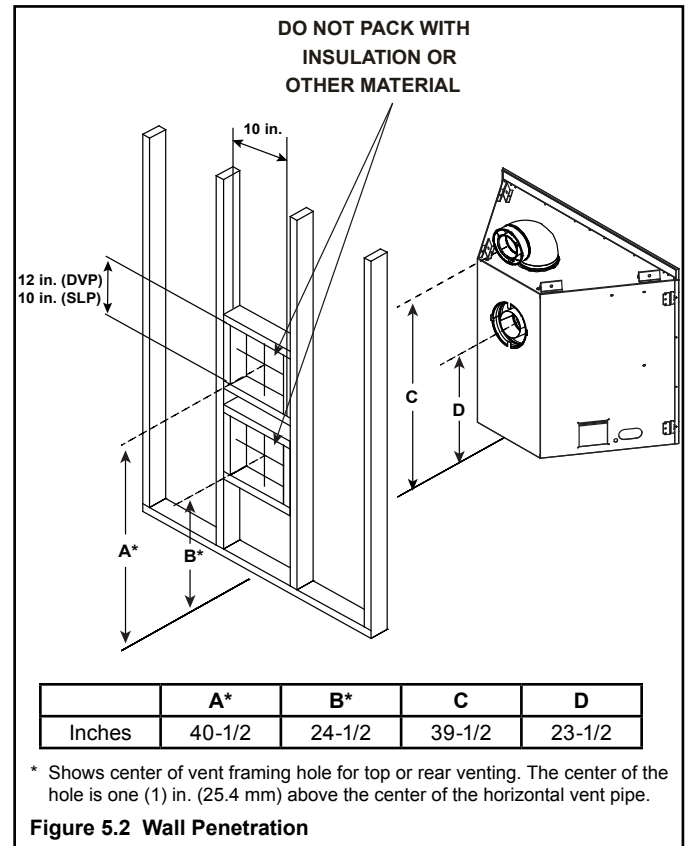

C. Ceiling Firestop/Floor Penetration Framing

WARNING! Risk of Fire! DO NOT pack insulation around the vent. Maintain clearances to vent to prevent overheating.

A ceiling firestop **MUST** be used between floors and attics.

- **DVP pipe only** - Frame an opening 10 in. by 10 in. (254 mm by 254 mm) whenever the vent penetrates a ceiling/floor (see Figure 5.3).
- **SLP pipe only** - Frame opening 9 in. x 9 in. (229 mm x 229 mm) whenever the vent penetrates a ceiling/floor (see Figure 5.3).
- Frame the area with the same sized lumber as used in ceiling/floor joist.
- The ceiling firestop may be installed above or below the ceiling joists when installed with an attic insulation shield. It must be under joists between floors that are not insulated. Refer to Figure 5.4.
- Secure in place with nails or screws.

WARNING! Risk of Fire! DO NOT pack insulation around the vent. Insulation must be kept back from the pipe to prevent overheating.

D. Install Attic Insulation Shield

WARNING! Fire Risk. The use of an attic shield is required to prevent loose materials or insulation from contacting the vent causing overheating and a fire.

The International Fuel Gas Code requires an attic shield constructed of 26 gauge minimum steel that extends at least 2 in. (51 mm) above insulation.

- Attic insulation shields must meet specified clearances to combustible materials and be secured in place.
- An attic insulation shield kit is available from Hearth & Home Technologies. Contact your dealer to order. Install attic insulation shield according to instructions included with kit.

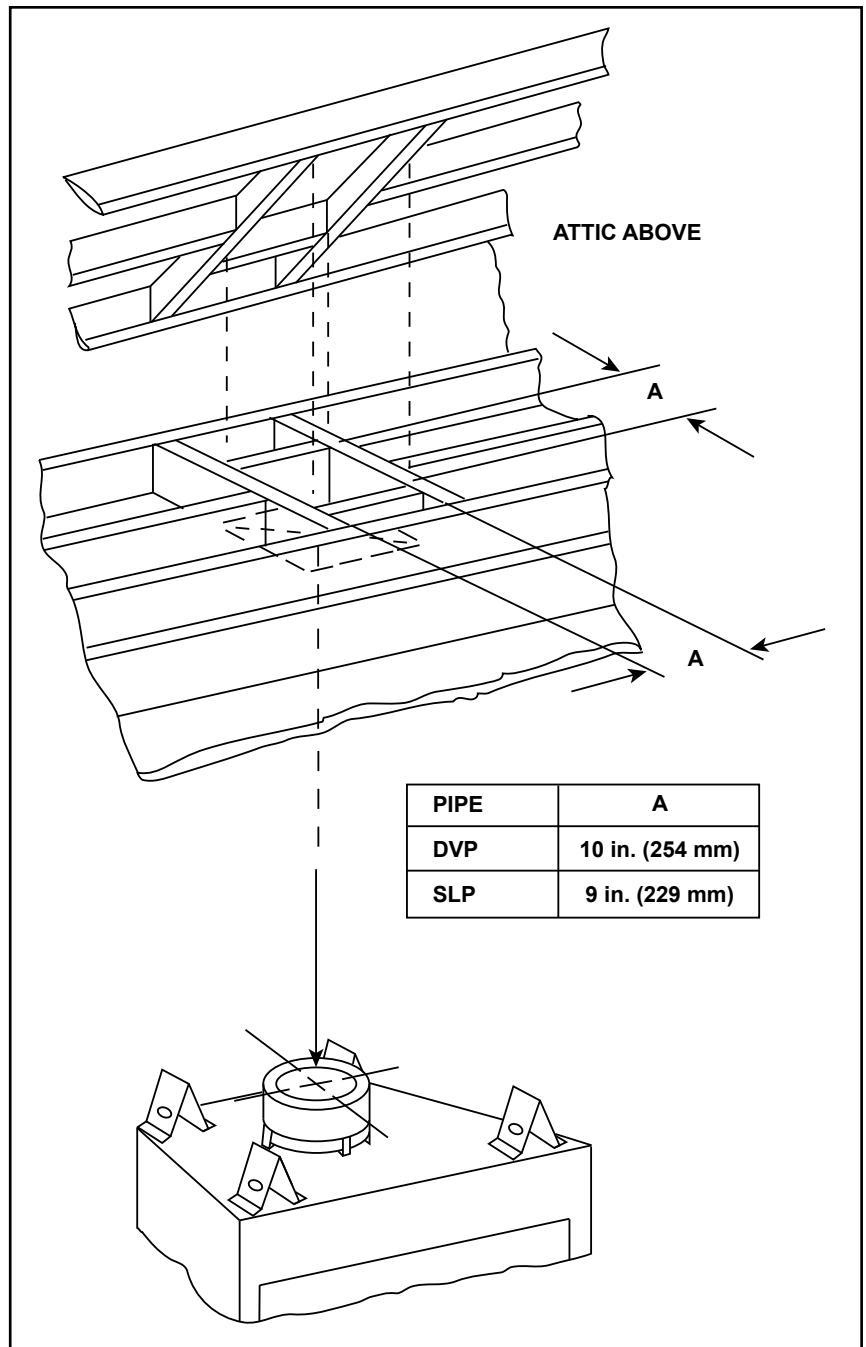

Figure 5.3 Installing Ceiling Firestop

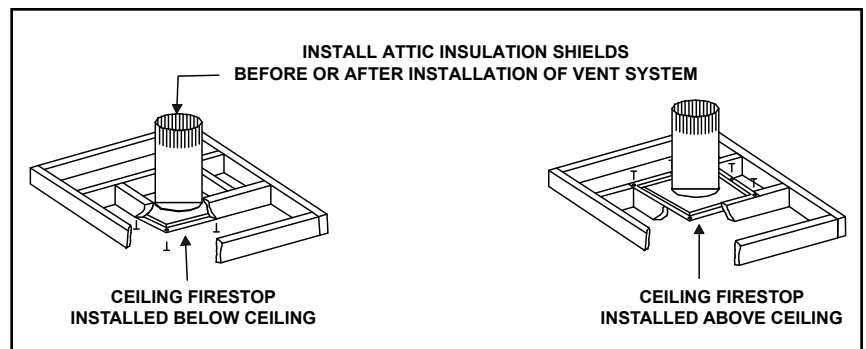

Figure 5.4 Installing the Attic Shield

6 Appliance Preparation

A. Top Vent

CAUTION! Risk of Cuts, Abrasions or Flying Debris. Wear protective gloves and safety glasses during installation. Sheet metal edges are sharp.

NOTICE: Once appliance is set up for top or rear venting, it CANNOT be changed at a later time.

- Remove the cover plate by removing the two screws holding it to the top of the appliance. Remove and discard the cover plate.

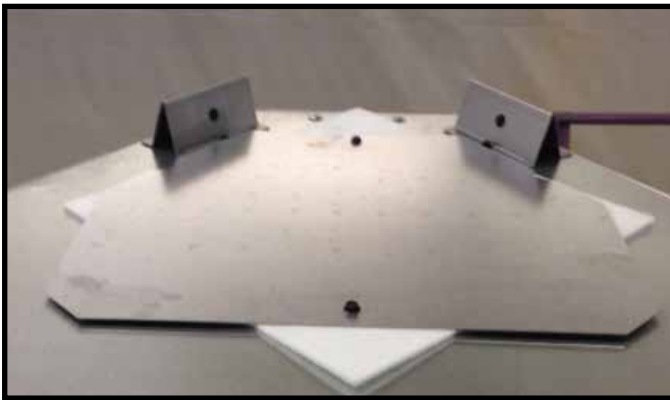

Figure 6.1

- Remove the center insulation plug.



Figure 6.2

- Cut the metal retaining band and fold the sides out.

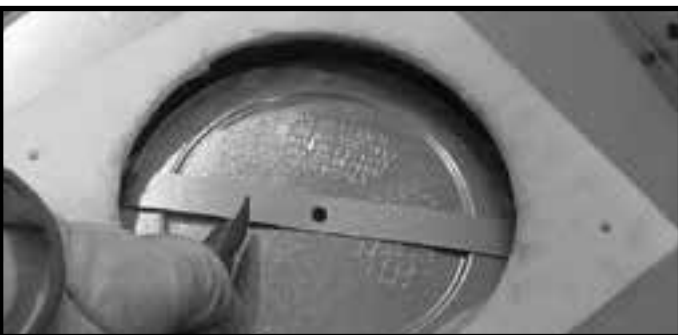

Figure 6.3

- Fold the center parts of the retaining band up and use to remove the vent cap.



Figure 6.4

- Discard the vent cap, remove and discard the insulation basket from the inner vent pipe. **Note:** Once the vent cap has been removed it cannot be reattached. Remove and discard insulation from outer vent pipe.



Figure 6.5

- Snap the first vent section into place.



Figure 6.6

Proceed to Section 6.B or 6.C.

Rear Vent

NOTICE: Once appliance is set up for top or rear venting, it **CANNOT** be changed at a later time.

- Fold the tabs toward the center of the vent cap (90°) and remove the insulation gasket.



Figure 6.7

- Cut the metal retaining band and fold the sides out.



Figure 6.8

- Fold the center parts of the retaining band out and use to remove the vent cap.



Figure 6.9

- Discard the vent cap, remove and discard the insulation basket.

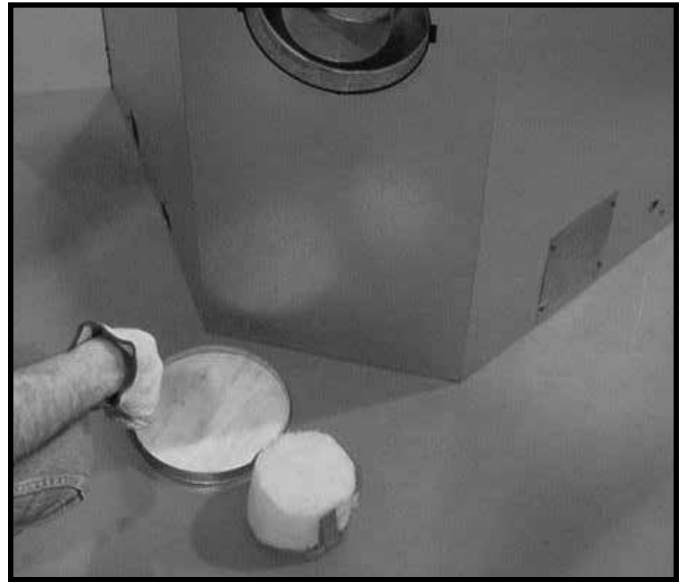

Figure 6.10

- Attach the first vent section (it will snap into place). Slide the insulation gasket onto the vent section, up against the appliance and over the tabs.

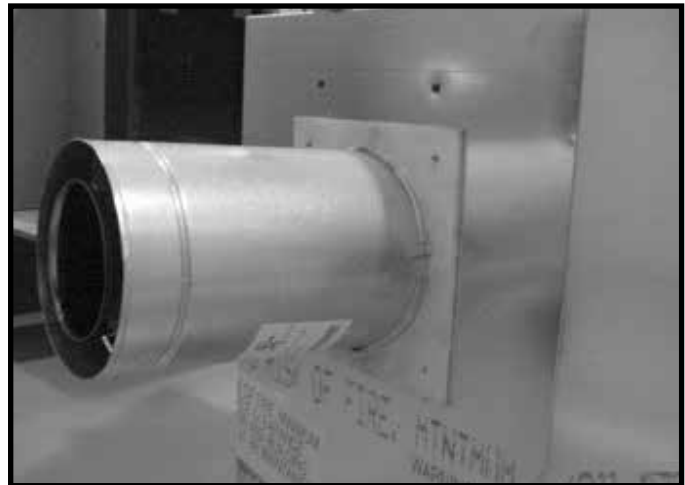

Figure 6.11

B. Prepare For Heat Management

NOTICE: Additional clearances are required for heat management systems installations. Provisions must be made in advance to ensure fit within the framing.

- Heat management systems include Heat-Zone® Gas and Heat-Out-Gas. Other systems may be available. Contact your dealer for information.
 - Locate the knockouts on the left and right sides of the appliance. Either one or two heat management may be installed. Remove the knockout(s) from the appliance with a tin snips.
 - Center the duct collar around the exposed hole and attach it to the appliance with 3 screws.
- Note:** Do this BEFORE final positioning of the appliance.
- Determine the location for the air register/fan housing assembly.

Reference the appropriate instructions included with the kit for the remaining installation steps.

C. Securing and Leveling the Appliance

⚠ WARNING



Risk of Fire!

Prevent contact with:

- Sagging or loose insulation
- Insulation backing or plastic
- Framing and other combustible materials

DO NOT remove standoffs or notch the framing around the appliance standoffs.

Failure to maintain air space clearance could cause overheating and fire.

Block openings into the chase to prevent entry of blown-in insulation. Make sure insulation and other materials are secured.

The diagram shows how to properly position and secure the appliance. See Figure 6.12. Nailing tabs are provided to secure the appliance to the framing members.

- Bend out nailing tabs on each side.
- Place the appliance into position.
- Keep nailing tabs flush with the framing.
- Level the appliance from side to side and front to back.
- Shim the appliance as necessary. It is acceptable to use wood shims underneath the appliance.
- Secure the appliance to the framing by using nails or screws through the nailing tabs. Use a minimum of one fastener per nailing tab.
- Optional: Secure the appliance to the floor by inserting two screws through the pilot holes at the bottom of the appliance.

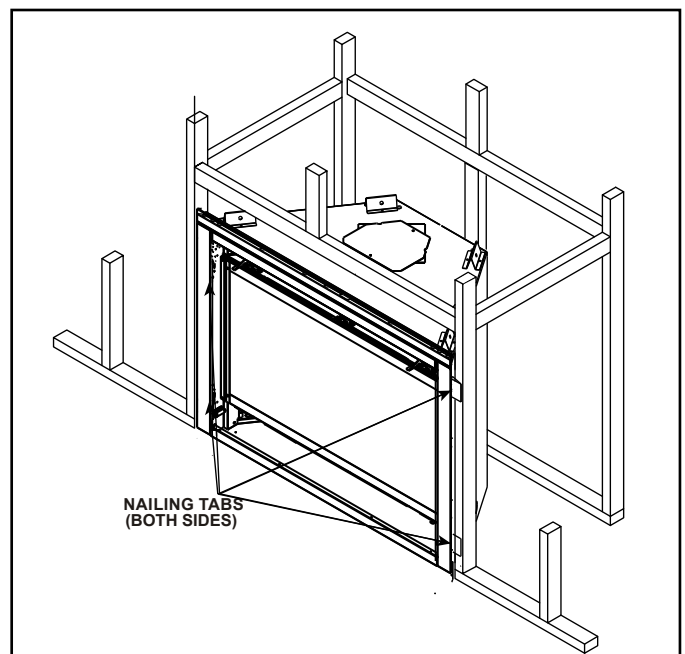

Figure 6.12 Proper Positioning and Securing of an Appliance

7 Venting and Chimneys

A. Assemble Vent Sections (DVP Pipe Only)

WARNING! Risk of Fire or Explosion! Vent sections *MUST* be installed correctly. Improperly installed vent sections could leak or cause appliance to overheat.

Attach Vent to the Firebox Assembly

Note: The end of the pipe sections with the lanced tabs will face toward the appliance.

Attach the first pipe section to the starting collar:

- Lanced pipe end of the starting collar.
- Inner pipe over inner collar.
- Push the pipe section until all lanced tabs snap in place.
- Lightly tug on pipe to confirm it has locked.

Requirement for Commercial, Multi-family (Multi-level exceeding two stories), or High-Rise Applications

WARNING! Risk of Fire or Explosion! DO NOT break silicone seals on slip sections. Use care when removing termination cap from slip pipe. If slip section seals are broken during removal of the termination cap, vent could leak.

All outer pipe joints must be sealed using one of the methods below, including the slip section that connects directly to the horizontal termination cap.

- Apply a bead of silicone sealant (300 °F minimum continuous exposure rating) inside the female outer pipe joint prior to joining sections. See Figure 7.1 **OR**

Apply a bead of silicone sealant (300 °F minimum continuous exposure rating) to the outside of connecting joint after joining sections **OR**

Apply aluminum foil tape (300 °F minimum continuous exposure rating) to the outside of connecting joint after joining sections. On horizontal pipe runs, it is recommended that the tape seam is positioned on the bottom side of the vent pipe.

- Only outer pipes need to be sealed. All unit collar, pipe, slip section, elbow and cap outer flues shall be sealed in this manner, unless otherwise stated.

Assemble Pipe Sections

Per Figure 7.2:

- Start the inner pipe on the lanced end of section A into the flared end of section B.
- Start the outer pipe of section A over the outer pipe of section B.
- Once both vents sections are started, push firmly until all lanced tabs lock into place.
- Lightly tug on the pipe to confirm the tabs have locked. It is acceptable to use screws no longer than 1/2 in. (13 mm) to hold outer pipe sections together. If predrilling holes, **DO NOT** penetrate inner pipe.

For 90° and 45° elbows that are changing the vent direction from horizontal to vertical, one screw minimum should be put in the outer flue at the horizontal elbow joint to prevent the elbow from rotating. Use screws no longer than 1/2 in. (13 mm). If predrilling screw holes, **DO NOT** penetrate inner pipe.

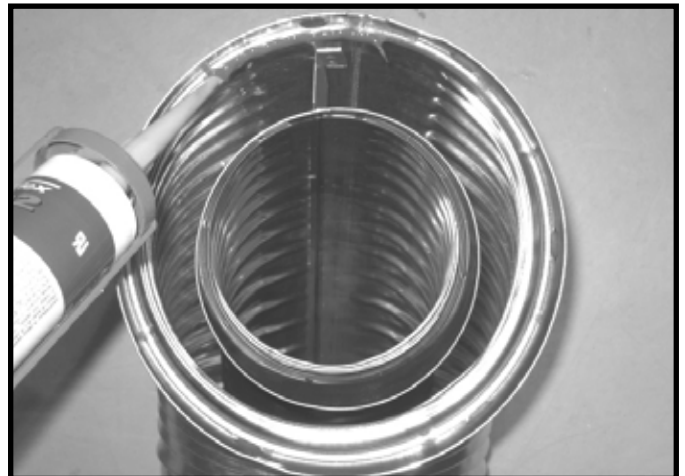

Figure 7.1 High Temperature Silicone Sealant

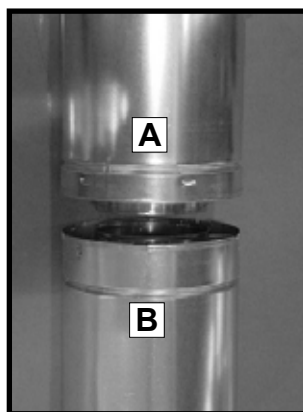

Figure 7.2

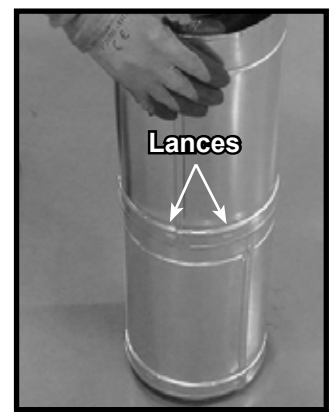
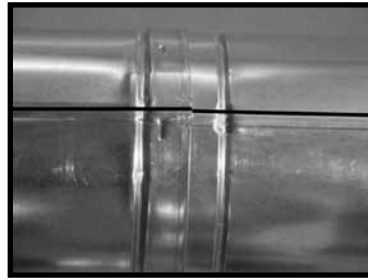

Figure 7.3

Note: Make sure that the seams are not aligned to prevent unintentional disconnection.



CORRECT



INCORRECT

Figure 7.4 Seams

Assemble Vent Sections (SLP Only)

To attach the first vent component to the starting collars of the appliance:

- Attach a DVP-SLP24 adapter to the starting collar of the appliance.
- Lock the vent components into place by sliding the pipe section onto the collar.
- Align the seam of the pipe and seam of collar to allow engagement. Rotate the vent component to lock into place. Use this procedure for all vent components. See Figure 7.5.
- Slide the gasket over the first vent section and place it flush to the appliance. This will prevent cold air infiltration. Caulk with a minimum of 300 °F continuous exposure rating may be used to hold the part in place.
- Continue adding vent components, locking each succeeding component into place.
- Ensure that each succeeding vent component is securely fitted and locked into the preceding component.

Required Commercial, Multi-family (Multi-level exceeding two stories), or High-Rise Applications

All outer pipe joints must be sealed with 100% silicone (300 °F minimum continuous exposure rating), including the slip section that connects directly to the horizontal termination cap.

- Apply a bead of silicone sealant (300 °F minimum continuous exposure rating) inside the female outer pipe joint prior to joining sections. See Figure 7.1. **OR**

Apply a bead of silicone sealant (300 °F minimum continuous exposure rating) to the outside of connecting joint after joining sections **OR**

Apply aluminum foil tape (300 °F minimum continuous exposure rating) to the outside of connecting joint after joining sections. On horizontal pipe runs, it is recommended that the tape seam is positioned on the bottom side of the vent pipe.

- Only outer pipes need to be sealed. All unit collar, pipe, slip section, elbow and cap outer flues shall be sealed in this manner, unless otherwise stated.

WARNING! Risk of Fire or Explosion! DO NOT break silicone seals on slip sections. Use care when removing termination cap from slip pipe. If slip section seals are broken during removal of the termination cap, vent could leak.

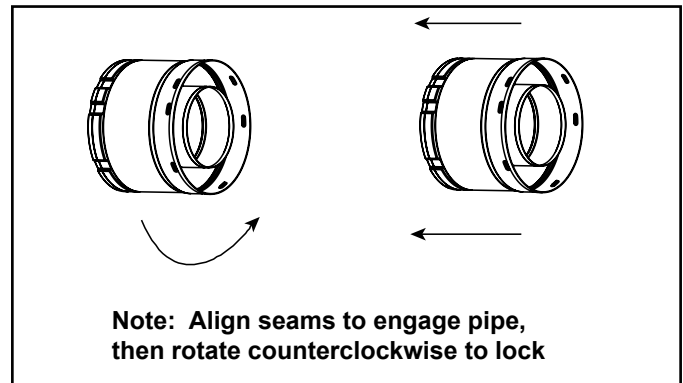

Figure 7.5 Adding Venting Components

B. Assemble Slip Sections

- Slide the inner flue of the slip section into the inner flue of the pipe section and the outer flue of the slip section over the outer flue of the pipe section. See Figure 7.6.
- Slide together to the desired length.

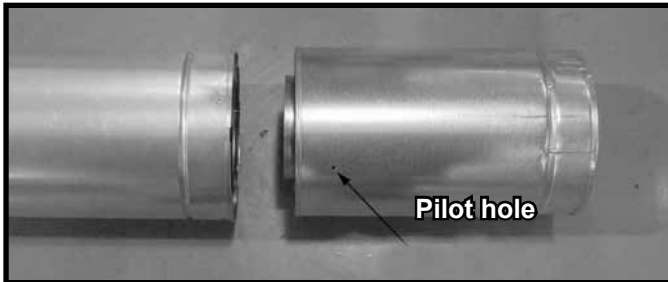

Figure 7.6 Slip Section Pilot Holes

- Maintain a 1-1/2 in. (38 mm) overlap between the slip section and the pipe section.
- Secure the pipe and slip section with two screws no longer than 1/2 in. (13 mm), using the pilot holes in the slip section. See Figure 7.7.

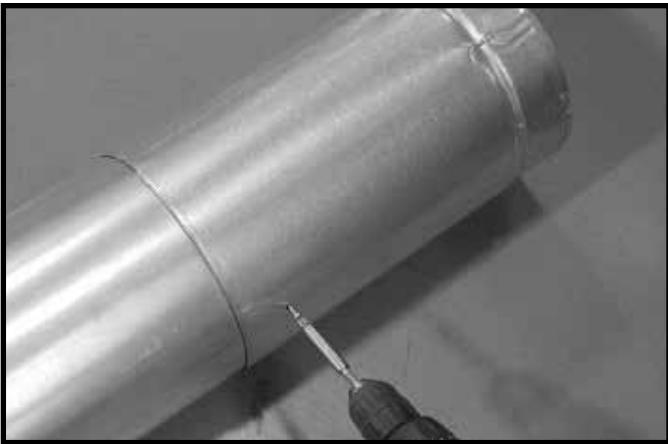

Figure 7.7 Screws into Slip Section

- Continue adding pipe as necessary following instructions in “Assembling Pipe Sections.”

NOTICE: If slip section is too long, the inner and outer flues of the slip section can be cut to the desired length.

NOTICE: When installing a vent system with an HRC termination cap, all pipe system joints shall be sealed using a high temperature silicone sealant (300 °F minimum continuous exposure rating).

- Apply a bead of silicone sealant (300 °F minimum continuous exposure rating) inside the female outer pipe joint prior to joining sections.
- Only outer pipes are sealed, sealing the inner flue is not required.
- All unit collar, pipe, slip section, elbow and cap outer flues shall be sealed.

C. Secure the Vent Sections

- Vertical runs originating off the top of the appliance, with no offsets, must be supported every 8 ft. (2.44 m) after the maximum allowed 25 ft. (7.62 m) of unsupported rise.
- Vertical runs originating off the rear of the appliance, or after any elbow, must be supported every 8 ft. (2.44 m).
- Horizontal runs must be supported every 5 feet (1.52 m).
- Vent supports or plumbers strap (spaced 120° apart) may be used to support vent sections. See Figures 7.8 and 7.9.
- Wall shield firestops may be used to provide horizontal support to vent sections.
- SLP ceiling firestops have tabs that may be used to provide vertical support.

WARNING! Risk of Fire, Explosion or Asphyxiation! Improper support could allow vent to sag and separate. Use vent run supports and connect vent sections per installation instructions. **DO NOT** allow vent to sag below connection point to appliance.

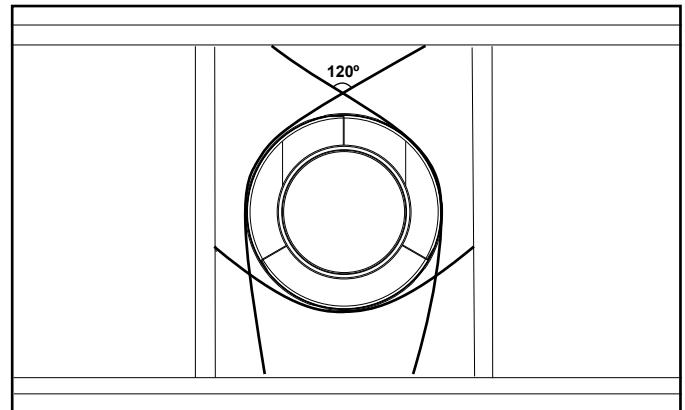

Figure 7.8 Securing Vertical Pipe Sections

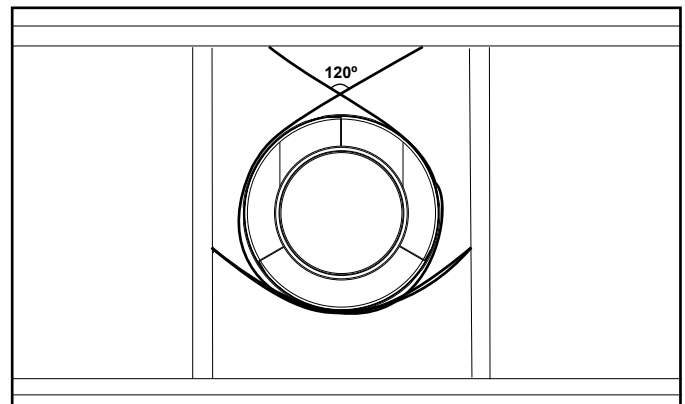

Figure 7.9 Securing Horizontal Pipe Sections

D. Disassemble Vent Sections

- Rotate either section (see Figure 7.10) so the seams on both pipe sections are aligned as shown in Figure 7.11.
- Pull carefully to separate the pieces of pipe.

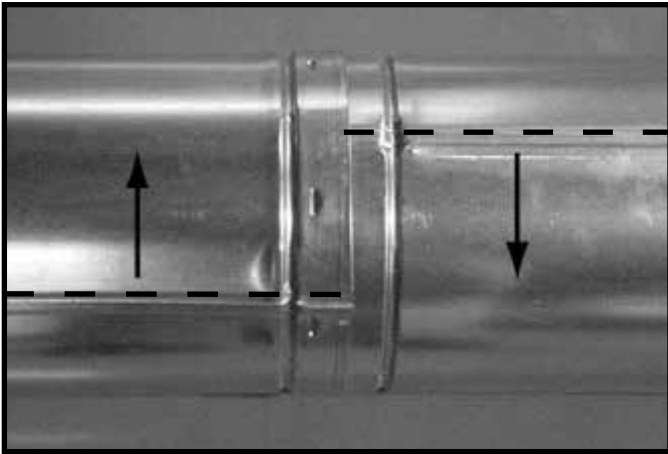

Figure 7.10 Rotate Seams for Disassembly

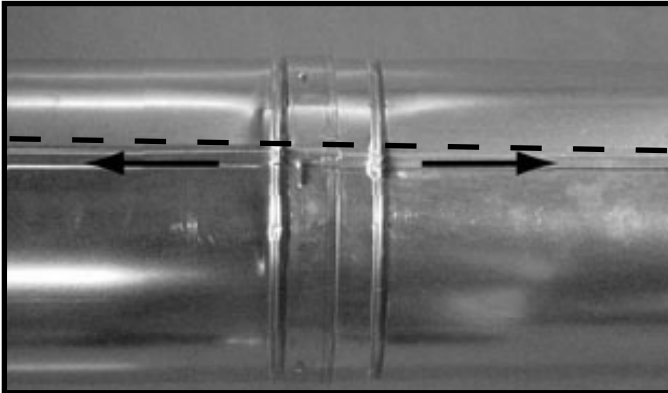

Figure 7.11 Align and Disassemble Vent Sections

E. Vertical Termination Requirements

Install and Seal Metal Roof Flashing

- See minimum vent heights for various pitched roofs (Section 4, Figure 4.1) to determine the length of pipe to extend through the roof.
- Slide the roof flashing over the pipe sections extending through the roof as shown in Figure 7.12.
- Use an elastomeric or silicone sealant with a minimum of 150 °F temperature rating to seal the metal roof flashing.

Note: When installing a silicone or EPDM pipe flashing boot on a metal roof, it is recommended to put a bead of 100% silicone sealant where the boot contacts the vent pipe to prevent the entry of water. Follow the manufacturer's recommendations when installing the boot.

NOTICE: Failure to properly seal the roof flashing and pipe seams could permit entry of water.

- Seal the gap between the roof flashing and the outside diameter of the pipe.
- Seal the perimeter of the flashing where it contacts the roof surface. See Figure 7.12.
- Seal the exposed pipe section seams that are located above the roof.

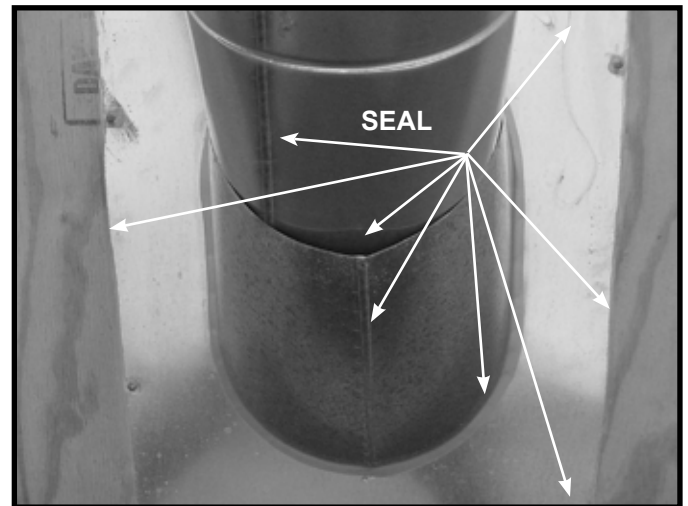

Figure 7.12

Assemble and Install Storm Collar

CAUTION! Risk of Cuts, Abrasions or Flying Debris. Wear protective gloves and safety glasses during installation. Sheet metal edges are sharp.

- Slide the storm collar onto the exposed pipe section and align brackets.
- Insert a bolt (provided) through the brackets and install nut. Do not completely tighten.



Figure 7.13 Insert Bolt into Brackets

- Slide the assembled storm collar down the pipe section until it rests on the roof flashing. See Figure 7.13.
- Tighten nut and make sure the collar is tight against the pipe section.
- Seal around the top of the storm collar. See Figure 7.14.

Install Vertical Termination Cap

- Attach the vertical termination cap by sliding the inner collar of the cap into the inner flue of the pipe section while placing the outer collar of the cap over the outer flue of the pipe section.
- Secure the cap by driving three self-tapping screws (supplied) through the pilot holes in the outer collar of the cap into the outer flue of the pipe. See Figure 7.14.

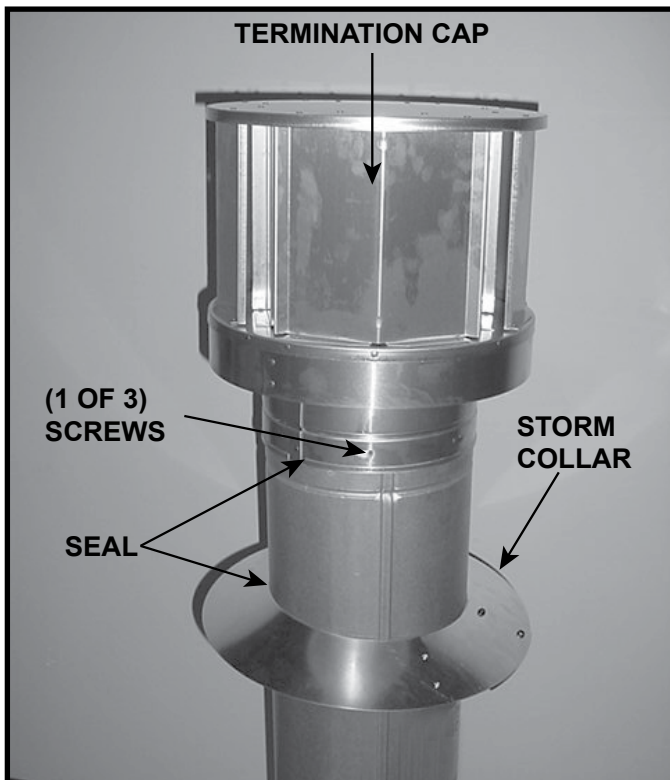

Figure 7.14

F. Horizontal Termination Requirements

Heat Shield Requirements for Horizontal Termination

WARNING! Risk of Fire! To prevent overheating and fire, heat shields must extend through the entire wall thickness.

- **DO NOT** remove the heat shields attached to the wall shield firestop and the horizontal termination cap (shown in Figure 7.15).
- Heat shields must overlap 1-1/2 in. (38 mm) minimum.

There are two sections of the heat shield. One section is factory-attached to the wall shield firestop. The other section is factory-attached to the cap. See Figure 7.15.

If the wall thickness does not allow the required 1-1/2 in. (38 mm) heat shield overlap when installed, an extended heat shield must be used.

- If the wall thickness is less than 4 in./102 mm (DVP) or 4-3/8 in./ 111 mm (SLP), the heat shields on the cap and wall shield firestop must be trimmed. A minimum 1-1/2 in. (38 mm) overlap **MUST** be maintained.
- Use an extended heat shield if the finished wall thickness is greater than 7-1/4 in. (184 mm).
- The extended heat shield may need to be cut to length maintaining sufficient length for a 1-1/2 in. (38 mm) overlap between heat shields.
- Attach the extended heat shield to either of the existing heat shields using the screws supplied with the extended heat shield. Refer to vent components diagrams in the back of this manual.
- Rest the small leg on the extended heat shield on top of the pipe section to properly space it from the pipe section.

Important Notice: Heat shields may not be field constructed.

Install Horizontal Termination Cap (DVP and SLP Pipe)

WARNING! Risk of Fire! The telescoping flue section of the termination cap **MUST** be used when connecting vent.

- 1-1/2 (38 mm) minimum overlap of flue telescoping section is required.

Failure to maintain overlap could cause overheating and fire.

- Vent termination must not be recessed in the wall. Siding may be brought to the edge of the cap base.
- Flash and seal as appropriate for siding material at outside edges of cap.
- When installing a horizontal termination cap, follow the cap location guidelines as prescribed by current **ANSI Z223.1** and **CAN/CGA-B149** installation codes and refer to Section 4 of this manual.

CAUTION! Risk of Burns! Local codes may require installation of a cap shield to prevent anything or anyone from touching the hot cap.

NOTICE: For certain exposures which require superior resistance to wind-driven rain penetration, a flashing kit and HRC caps are available. When penetrating a brick wall, a brick extension kit is available for framing the brick.

Note: When using termination caps with factory-supplied heat shield attached, no additional wall shield firestop is required on the exterior side of a combustible wall.

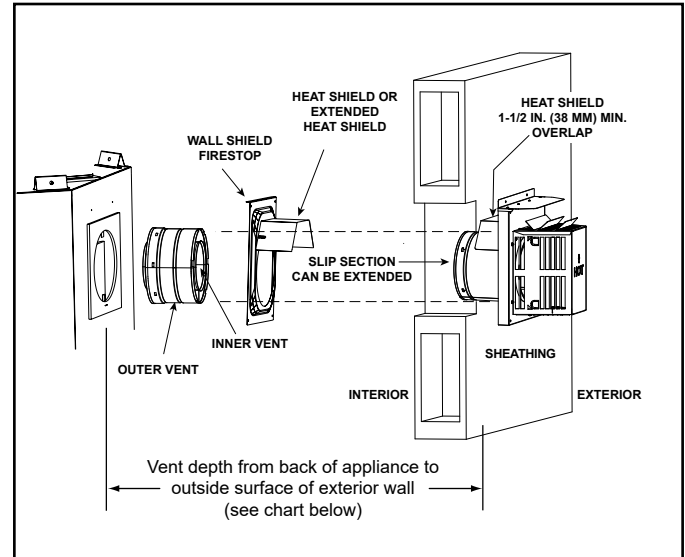

Figure 7.15 Venting Through the Wall

Cap Specification Chart (depth without using additional pipe sections)

NNXT Series	DVP-TRAPK1 Top Vent Depth	DVP-TRAP1 Rear Vent Depth	DVP-TRAPK2 Top Vent Depth	DVP-TRAP2 Rear Vent Depth	SLP-TRAP1 Top Vent Depth	SLP-TRAP2 Top Vent Depth
		4 1/2 to 6 3/8 in.	3 to 4 7/8 in.	6 7/8 to 10 7/8 in.	5 3/8 to 9 3/8 in.	2 to 3 7/8 in.
	DVP-HPC1 Top Vent Depth	DVP-HPC1 Rear Vent Depth	DVP-HPC2 Top Vent Depth	DVP-HPC2 Rear Vent Depth		
	4 1/2 to 6 5/8 in.	3 to 5 1/8 in.	6 5/8 to 10 3/4 in.	5 1/8 to 9 1/4 in.		

DVP-TRAP1 can adjust 1 1/2 in. (3 1/8 to 4 5/8)

DVP-TRAP2 can adjust 4 in. (5 3/8 to 9 3/8)

SLP-TRAP1 can adjust 1 5/8 in. (3 1/8 to 4 3/4)

SLP-TRAP2 can adjust 4 in. (5 1/4 to 9 1/4)

DVP-HPC1 can adjust 2 1/8 in. (4 1/4 to 6 3/8)

DVP-HPC2 can adjust 4 1/8 in. (6 3/8 to 10 1/2)

G. Shrouds

HHT Shrouds

- You may install a shroud with this fireplace. See Section 12.B for a list of UL Listed shrouds. Follow the instructions included with these optional components

Field Constructed Shrouds

WARNING! Risk of Fire! Shrouds must be constructed as specified. Improper construction may overheat chase top.

- Chase top shrouds may be field constructed where permitted by regional building codes.

NOTICE: Some regional codes require an agency-Listed shroud. Consult your local building officials.

- The following field constructed shroud designs have been tested for Hearth Technologies fireplace systems and termination caps.
- The shrouds must be constructed from a minimum .018 in. (26 ga) thick aluminized steel.
- The wire mesh is optional but recommended and must be .018 in. thick minimum, 1/2 in. mesh.

Mailbox Style Shroud (may be used with DVP-TV, DVP-TVHW, SLP-TVHW)

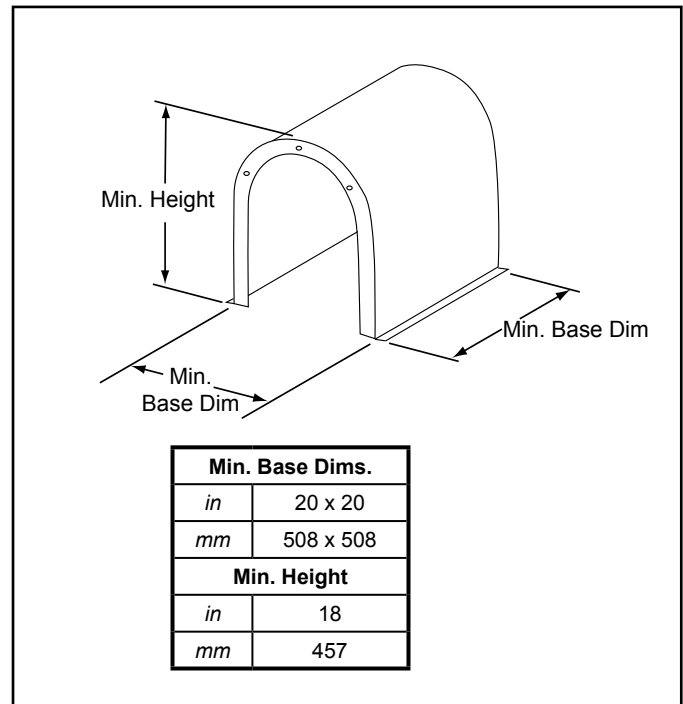

Figure 7.17 Mailbox Style Shroud Dimensions

Open Top Shroud (may be used with DVP-TV, DVP-TVHW, SLP-TVHW)

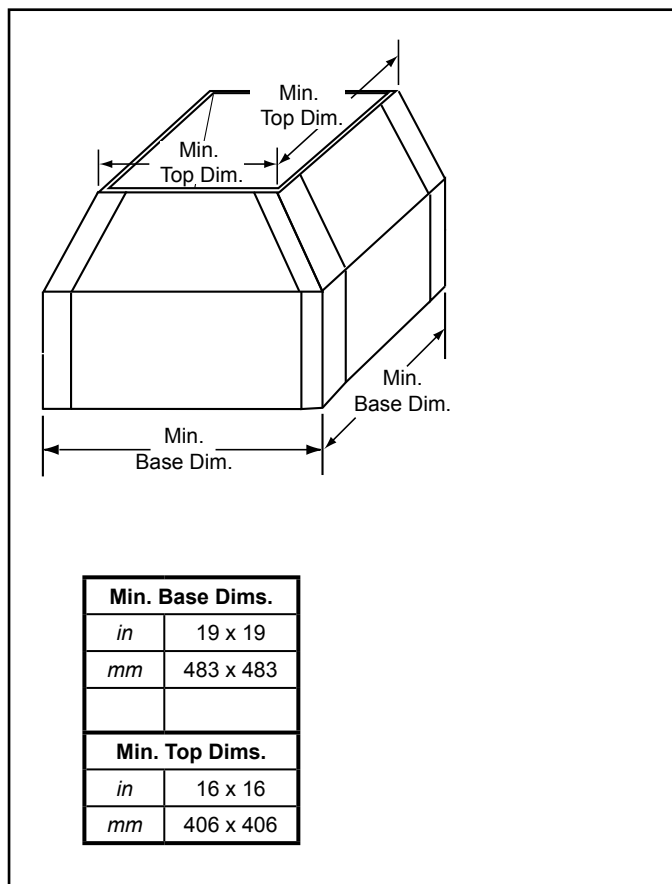

Figure 7.16 Open Top Shroud Dimensions

Roofed Style Shroud (may be used with DVP-TV, DVP-TVHW, SLP-TVHW)

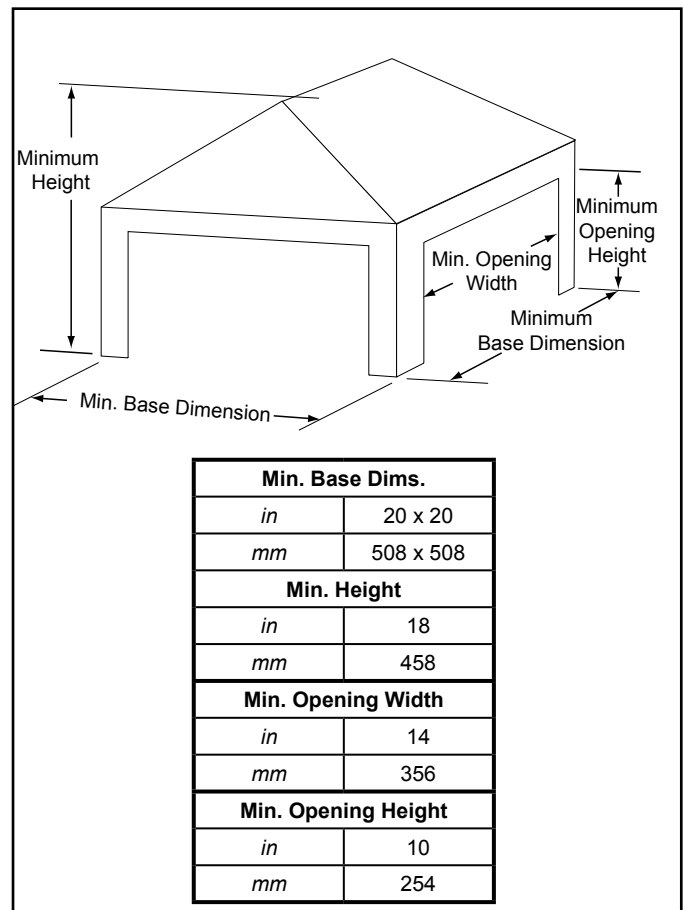

Figure 7.18 Roofed Style Shroud Dimensions

8 Electrical Information

A. General Information

WARNING! Risk of Shock! DO NOT wire 110-120 VAC to the ignition module or to the appliance wall switch. Incorrect wiring will damage controls.

NOTICE: This appliance must be electrically wired and grounded in accordance with local codes or, in the absence of local codes, with **National Electric Code ANSI/NFPA 70-latest edition** or the **Canadian Electric Code CSA C22.1**.

- Wire the appliance circuit using a minimum 14-2 AWG with ground to unswitched 110-120 VAC. This is required for use of optional accessories (standing pilot ignition) or proper operation of the appliance (IntelliFire® ignition).
- A 110-120 VAC circuit for this product must be protected with ground-fault circuit interrupter protection, in compliance with the applicable electrical codes, when it is installed in locations such as in bathrooms or near sinks.
- Low voltage and 110-120 VAC voltage cannot be shared within the same wall box.
- In some instances, the spark ignition of the fireplace may cause intermittent, non-damaging, interference during the lighting sequence with a TV plugged into the same circuit. It is recommended that the fireplace and TV use different circuits to mitigate the interference potential. If interference is occurring on the same circuit, the use of surge protectors may help alleviate the interference.

Junction Box Installation

If the box is being wired from the **INSIDE** of the appliance:

- Remove the screw attaching the junction box/receptacle to the outer shell, rotate the junction box inward to disengage it from the outer shell. See Figure 8.1.
- Pull the electrical wires from outside the appliance through the opening into the valve compartment and secure wires with a Romex connector. See Figure 8.1.
- Make all necessary wire connections to the junction box/receptacle and reattach the junction box/receptacle to the outer shell.

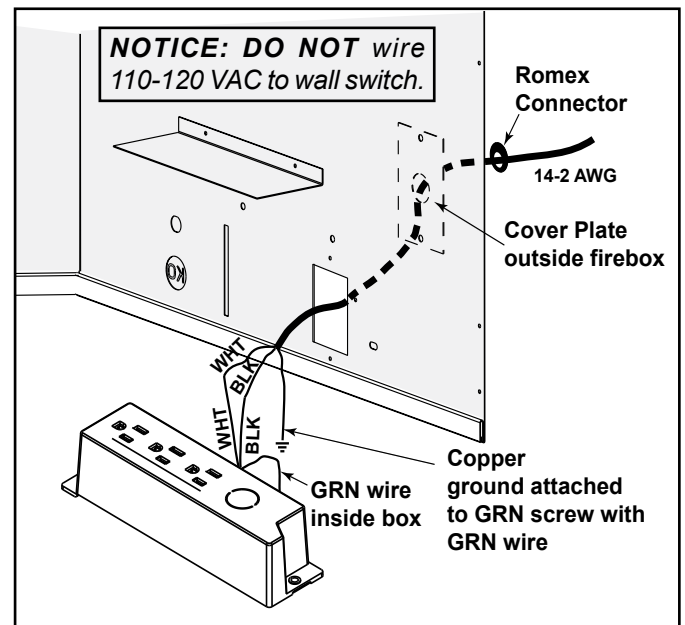

Figure 8.1 Junction Box Detail

Accessories Requirements

- This appliance may be used with a wall switch, wall mounted thermostat and/or a remote control.

Wiring for optional Hearth & Home Technologies approved accessories should be done now to avoid reconstruction. Follow instructions that come with those accessories.

Electrical Service and Repair

WARNING! Risk of Shock! Label all wires prior to disconnection when servicing controls. Wiring errors could cause improper and dangerous operation. Verify proper operation after servicing.

WARNING! Risk of Shock! Replace damaged wire with type 105° C rated wire. Wire must have high temperature insulation.

B. Wiring Requirements

IntelliFire Touch® Ignition System Wiring

- Wire the appliance junction box to 110-120 VAC for proper operation of the appliance.

WARNING! Risk of Shock or Explosion! DO NOT wire IPI controlled appliance junction box to a switched circuit. Incorrect wiring will override IPI safety lockout.

- Refer to Figure 8.2 IntelliFire Touch (IPI) Wiring Diagram.
- This appliance is equipped with an IntelliFire control valve which operates on a 6 volt system.

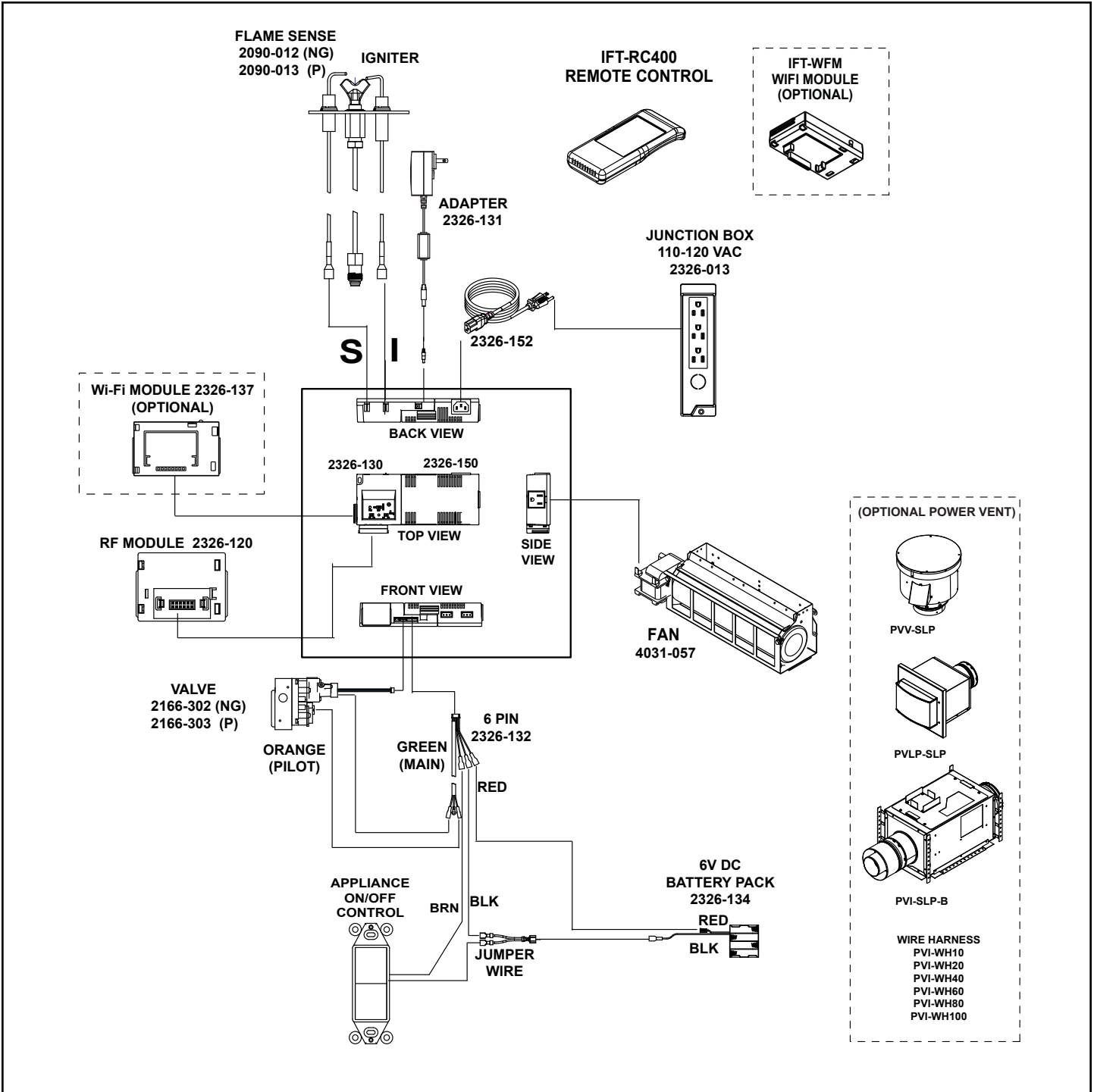

Figure 8.2 IntelliFire Touch Wiring Diagram

Wall Switch Installation for Fan (Optional)

The fan can be used in conjunction with a remotely located wall mounted switch or a BC10 (Blower Control Wall Switch).

- The power supply for the appliance must be brought into the appliance junction box.
- The wires to the remotely mounted switch or BC10 must plug into the black female terminals on harness. See Figure 8.3.
- The white wire connector on harness is not used and must be capped or terminated per local electrical code requirements.
- All wiring to remotely mounted switch or BC10 to be compliant with all local electrical code requirements.
- Harness shown in Figure 8.3 is available from your local dealer.

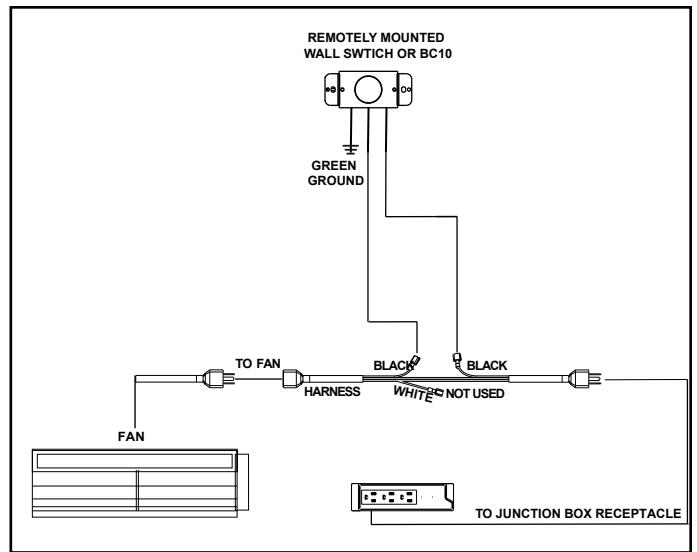

Figure 8.3 GFK21B or GFK4B Fan Kit and Remotely Mounted Switch or BC10

9 Gas Information

A. Fuel Conversion

- Make sure the appliance is compatible with available gas types.
- Conversions must be made by a qualified service technician using Hearth & Home Technologies specified and approved parts.

B. Gas Pressure

⚠ WARNING



Fire Risk.
Risk of Fire! Risk of Explosion!
Incorrect pressure will damage valve.

- Isolate gas supply piping BEFORE pressure testing gas line at test pressures above 1/2 psig.
- Close the manual shutoff valve BEFORE pressure testing gas line at test pressures equal to or less than 1/2 psig.

- Optimum appliance performance requires proper input pressures.
- Gas line sizing requirements will be determined in ANSI Z223.1 National Fuel Gas Code in the USA and CAN/CGA B149 in Canada.
- Pressure requirements are:

Gas Pressure	Natural Gas	Propane
Minimum inlet pressure	5.0 in. w.c.	11.0 in. w.c.
Maximum inlet pressure	10.0 in. w.c.	13.0 in. w.c.
Manifold pressure	3.5 in. w.c.	10.0 in. w.c.

- Verify inlet pressures. Verify minimum pressures when other household gas appliances are operating.
- Install regulator upstream of valve if line pressure is greater than 1/2 psig.

Note: Have the gas supply line installed in accordance with local codes, if any. If not, follow ANSI Z223.1. Installation should be done by a qualified installer approved and/or licensed as required by the locality. (In the Commonwealth of Massachusetts installation must be performed by a licensed plumber or gas fitter).

Note: A listed (and Commonwealth of Massachusetts approved) 1/2 in. (13 mm) T-handle manual shut-off valve and flexible gas connector are connected to the 1/2 in. (13 mm) control valve inlet.

- **If substituting for these components, please consult local codes for compliance.**

C. Gas Connection

- Refer to Section 3 for location of gas line access in appliance.
- Gas line may be run through knockout(s) provided.
- The gap between supply piping and gas access hole may be sealed with caulk or aluminum foil tape with a minimum of 300 °F continuous exposure rating or stuffed with non-combustible, unfaced insulation to prevent cold air infiltration.
- Ensure that gas line does not come in contact with outer wrap of the appliance. Follow local codes.
- Pipe incoming gas line into valve compartment.
- Connect incoming gas line to the 1/2 in. (13 mm) NPT connection on manual shutoff valve.

WARNING! Risk of Fire or Explosion! Support control when attaching pipe to prevent bending gas line.

WARNING! Risk of Fire or Explosion! Gas build-up during line purge could ignite.

- A small amount of air will be in the gas supply lines.
- *Ensure adequate ventilation.*
- *Ensure there are no ignition sources such as sparks or open flames.*

Light the appliance. It will take a short time for air to purge from lines. When purging is complete the appliance will light and operate normally.

WARNING! Risk of Fire, Explosion or Asphyxiation! Check all fittings and connections with a non-corrosive commercially available leak-check solution. **DO NOT** use open flame. Fittings and connections could have loosened during shipping and handling.

D. High Altitude Installations

NOTICE: If the heating value of the gas has been reduced, these rules do not apply. Check with your local gas utility or authorities having jurisdiction.

When installing above 2000 feet elevation:

- In the USA: Reduce input rate 4% for each 1000 feet above 2000 feet.
- In CANADA: Input ratings are certified without a reduction of input rate for elevations up to 4500 feet (1370 m) above sea level. Please consult provincial and/or local authorities having jurisdiction for installations at elevations above 4500 feet (1370 m).

Check with your local gas utility to determine proper orifice size.

E. Air Shutter Setting

Air shutter setting should be adjusted by a qualified installer at the time of installation.

- The air shutter is set at the factory for minimum vertical vent run. It may need to be adjusted for other venting scenarios.
- Adjust air shutter for longer vertical runs. See Figure 9.1. Turn the thumbscrew to open or close the air shutter. It may be necessary to use a pliers or crescent wrench to adjust the shutter. See chart below for correct shutter settings. The shutter measurement is taken from the bottom of the tub to the bottom of the thumbscrew. See Figure 9.1.

Note: Adjust air shutter after flame has reached full maturity (approximately 20-40 minutes).

CAUTION! Risk of Burns! Components are HOT. Wear protective gloves when adjusting shutter.

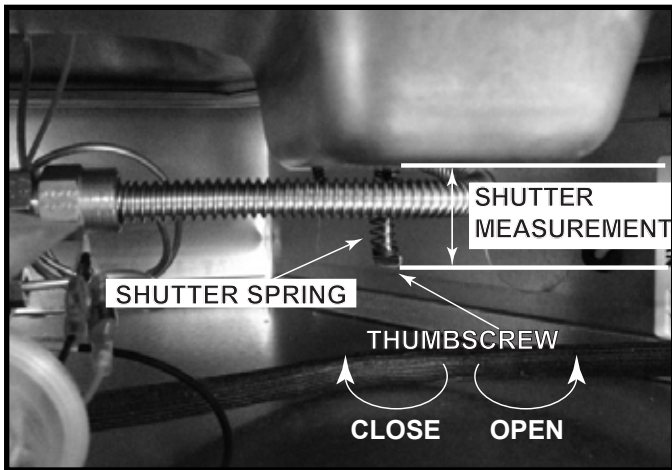

Figure 9.1 Air Shutter

Note: The air shutter is equipped with a compression spring that helps to maintain the shutter position during transportation. It may be necessary to relieve this spring pressure on the thumb screw to adjust the shutter.

Air Shutter Settings (Factory Set to Minimum Vent Run)

MODEL	GAS TYPE	MINIMUM VENT RUN	MAXIMUM VENT RUN
NNXT33-IFT	NG	3/4 IN.	3/4 IN.
NNXT33L-IFT	PROPANE	3/4 IN.	3/4 IN.
NNXT36-IFT	NG	3/4 IN.	3/4 IN.
NNXT36L-IFT	PROPANE	3/4 IN.	3/4 IN.

Minimum and maximum shutter settings are set up to appear like Figure 4.24.

- Minimum vent run consists of enough horizontal vent pipe to exit 2 X 6 wall construction (approximately 8 inches).
- Maximum vent run consists of “H Maximum” on Figure 4.24.

Note: All vent runs may need to be evaluated for ideal shutter settings. Shutter distances may vary due to vent run, fuel quality, and elevation.

10 Finishing

A. Facing Material

⚠ WARNING

Risk of Fire!

DO NOT apply combustible materials beyond the minimum clearances. Comply with all minimum clearances to combustibles as specified in this manual. Materials overlapping into non-combustible zones could ignite and will interfere with air flow through decorative barrier fronts.

- Metal front of appliance may be covered with non-combustible materials only.
- Facing and/or finishing materials must not interfere with air flow through decorative barrier fronts, removal of decorative barrier fronts or access for service.
- Facing and/or finishing materials must never overhang into the glass opening.
- Observe all clearances when applying combustible materials.
- Seal gaps between the finished wall and appliance top and sides using a 300 °F minimum sealant.

NOTICE: Surface temperatures around the appliance will become warm while the appliance is in operation. Ensure finishing materials used for all surfaces (floor, walls, mantels, etc.) will withstand temperatures up to 190 °F.

B. Mantel and Wall Projections

WARNING! Risk of Fire! Comply with all minimum clearances to combustibles as specified. Framing or finishing material closer than the minimums listed must be constructed entirely of non-combustible materials (i.e., steel studs, concrete board, etc).

Note: Mantel measurement is taken from top of the opening, NOT the top of the fireplace.

Combustible Mantels

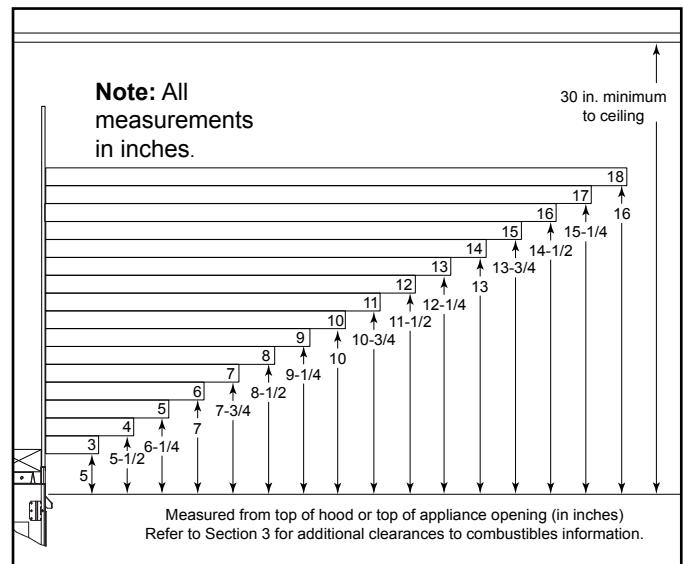

Figure 10.1 Minimum Vertical and Maximum Horizontal Dimensions

Combustible Mantel Legs or Wall Projections

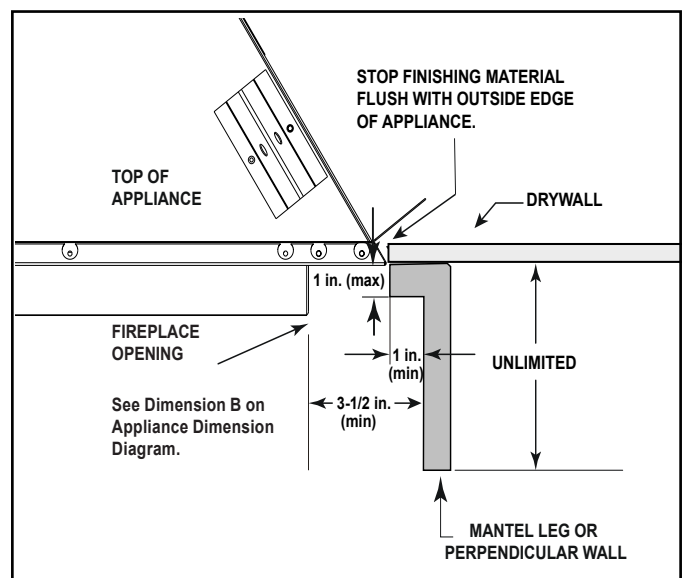

Figure 10.2 Mantel Leg or Wall Projections (Acceptable on both sides of opening)

C. Non-combustible Mantel and Wall Projections

Only decorative barrier fronts certified for use with this appliance model may be used. Contact your dealer for a list of decorative fronts that may be used. The finishing material thicknesses allowed are noted below.

Non-Combustible Mantels

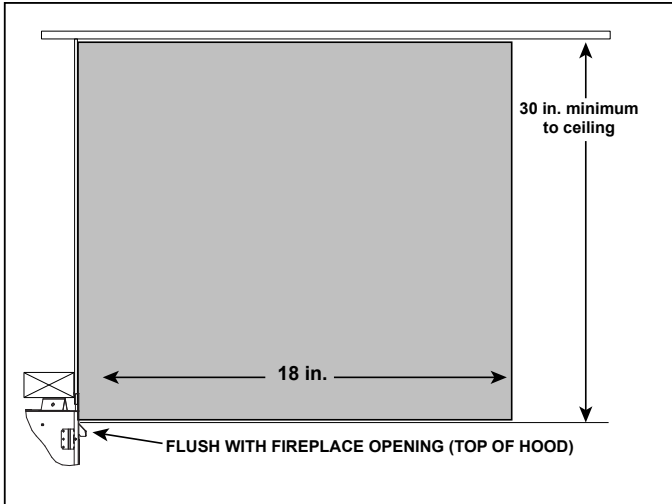

Figure 10.3 Minimum Vertical and Maximum Horizontal Dimensions for Non-Combustible Mantels

Non-Combustible Mantel Legs or Wall Projections

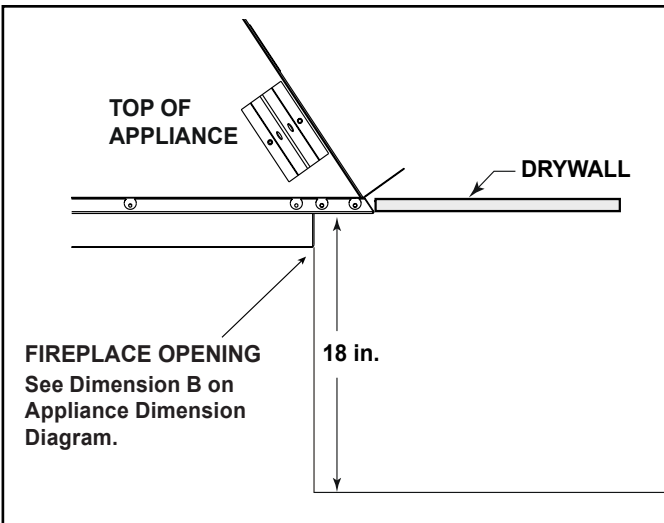

Figure 10.4 Non-Combustible Mantel Leg or Wall Projections (Acceptable on both sides of opening)

11 Appliance Setup

A. Remove the Shipping Materials

Remove shipping materials from inside or underneath the firebox.

- The splatter guard is a piece of corrugated material used to protect the appliance during the installation process before finishing work on the whole hearth is complete. Splatter guards may be factory installed or accompany the decorative barrier front of the appliance, depending on the fireplace model. Splatter guards must be removed before appliance is fired.

WARNING! Risk of Fire! Close the ball valve before installing the splatter guard to prevent accidental lighting. Remove the splatter guard before lighting the appliance.

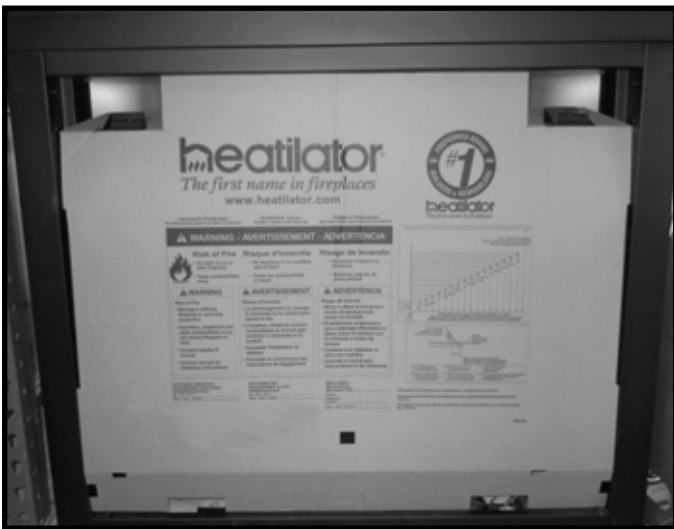

Figure 11.1 Appliance Unwrapped

B. Clean the Appliance

Clean/vacuum any sawdust that may have accumulated inside the firebox or underneath in the control cavity.

C. Install Burner Media / Embers

WARNING! Risk of Explosion! Follow mineral wool placement instructions. DO NOT place mineral wool on or near rear burner ports. Replace mineral wool material annually. Improperly placed mineral wool interferes with proper burner operation.

Note: It may be helpful to temporarily remove Log #5 to place the mineral wool. If removed, replace log according to log placement instructions.

- Mineral wool is shipped with this gas appliance.
- Place a small amount of 1/2 in. diameter pieces (dime-size) mineral wool on the burner pan as shown in Figure 11.3. The mineral wool may be placed loosely over the front burner port holes in the burner pan. Do NOT press them onto or into the burner port holes. This will provide the “glowing embers” look.
- It is not necessary to use the entire bag. Save the remaining mineral wool for future use.
- It is permissible to place a small amount of mineral wool or lava rock over screw heads that are used to fasten the rear logs.

⚠ WARNING



RISK OF EXPLOSION!

- Place lava rock, mineral wool and vermiculite according to instructions.
- Do NOT place lava rock or mineral wool in a position that they may fall into pilot area.
- Improperly placed lava rock or mineral wool interferes with proper burner operation. Delayed ignition could occur.
- Use ONLY Hearth & Home Technologies-approved lava rock or mineral wool.
- Some models may not require use of entire contents of bag.

Place the Lava Rock

Place the lava rock in an even layer just heavy enough to cover the metal surface. Stay within the zone indicated in Figure 11.3. It is not necessary to use the entire bag. Save the remaining amount for future use.

D. Install Control Heat Shield

The control heat shield **MUST** be placed over the control plate before operating the appliance. Not doing so may result in overheating the controls on the plate.

- Verify that the control heat shield is installed and legs are on bottom pan of appliance. See Figure 11.2.



Figure 11.2 Control Heat Shield - Installed

- Make sure all wires are under the top of the control heat shield and that there are no wires pinched between legs and the control heat shield.

E. Install Fixed Glass Assembly

WARNING! Risk of Asphyxiation! Handle fixed glass assembly with care. Inspect the gasket to ensure it is undamaged and inspect the glass for cracks, chips or scratches.

- **DO NOT** strike, slam or scratch glass.
- **DO NOT** operate fireplace with glass removed, cracked, broken or scratched.
- Replace as a complete assembly.
- Set the glass panel on the lower two glass assembly latches, ensuring the glass panel is centered in the opening.
- Replace glass latches.

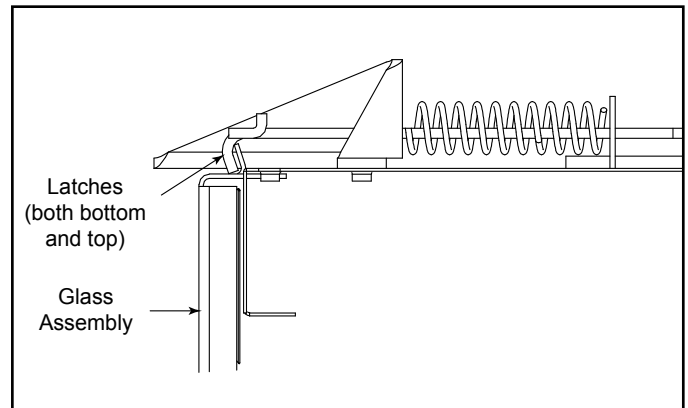

Figure 11.4 Fixed Glass Assembly

F. Install Decorative Barrier Front

WARNING! Risk of Fire! Install **ONLY** doors or fronts approved by Hearth & Home Technologies. Unapproved doors or fronts could cause fireplace to overheat.

This fireplace has been supplied with an integral barrier to prevent direct contact with the fixed glass panel. DO NOT operate the fireplace with the barrier removed.

Contact your dealer or Hearth & Home Technologies if the barrier is not present or help is needed to properly install one.

For more information refer to the instructions supplied with your decorative barrier front.

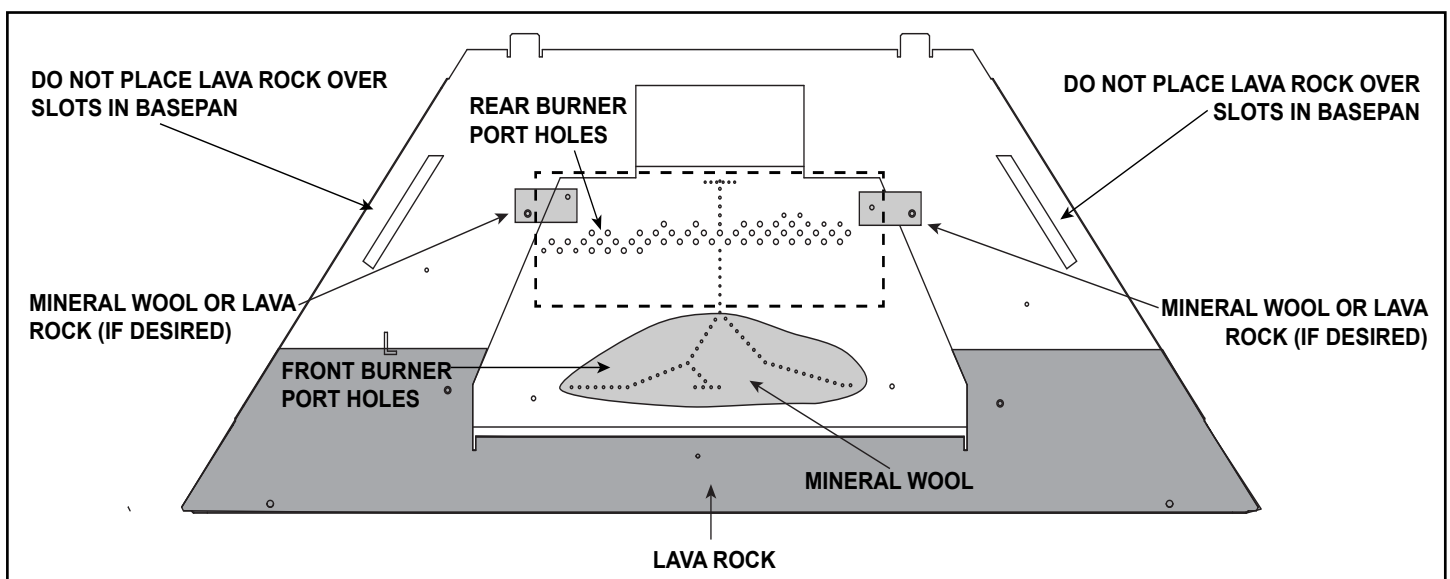

Figure 11.3 Placement of Mineral Wool and Lava Rock

G. Install Logs

LOG PLACEMENT INSTRUCTIONS

Log Set Assembly: SRV2384-070, SRV2385-070

Models: NNXT33-IFT, NNXT33L-IFT NNXT36-IFT, NNXT36L-IFT

See Table 1 for corresponding log set and individual logs for each size Novus model.

SIZE	33	36
ASSEMBLY	SRV2384-070	SRV2385-070
LOG 1	SRV2384-071	SRV2384-071
LOG 2	SRV2380-072	SRV2381-072
LOG 3	SRV2384-073	SRV2385-073
LOG 4	SRV2380-074	SRV2380-074
LOG 5	SRV2384-075	SRV2385-075
LOG 6	SRV2384-076	SRV2385-076

Table 1.

CAUTION: Logs are fragile, handle with care.

The log set is shipped from the factory with three logs already in place on the hearth pan. See Figure 1.

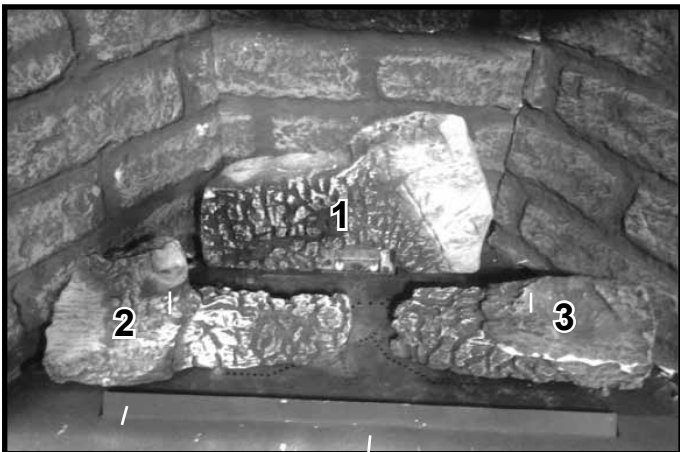

Figure 1. Log Set Shown as Shipped

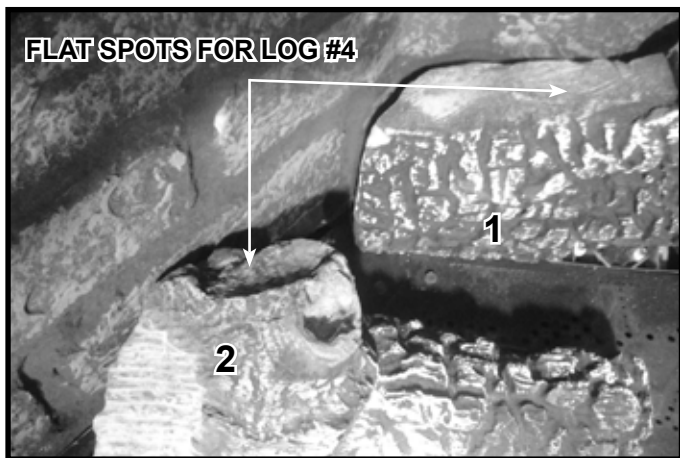

Figure 2. Locations of Flat Spots for Log #4

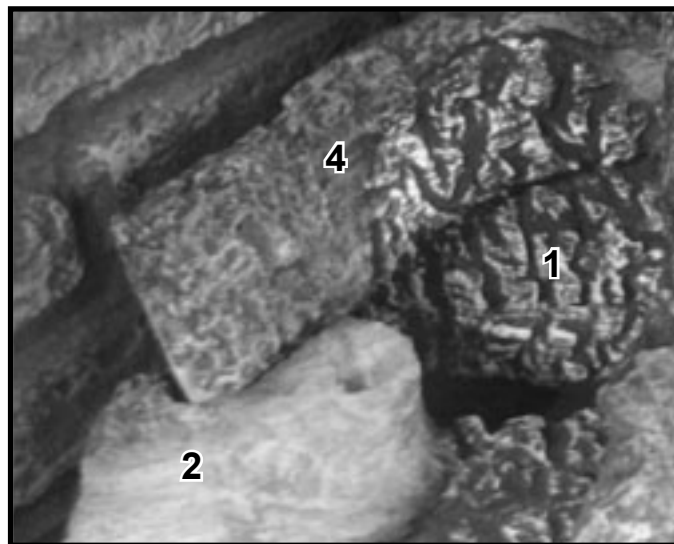

Figure 3. Log #4 in Position

LOG #4: Place Log #4 into position by setting the left end of Log #4 into the flat spot on Log #2 and then resting the right end, or nose, of Log #4 on the flat spot on Log #1. Figure 2 shows locations of flat spots. Figure 3 shows Log #4 installed.

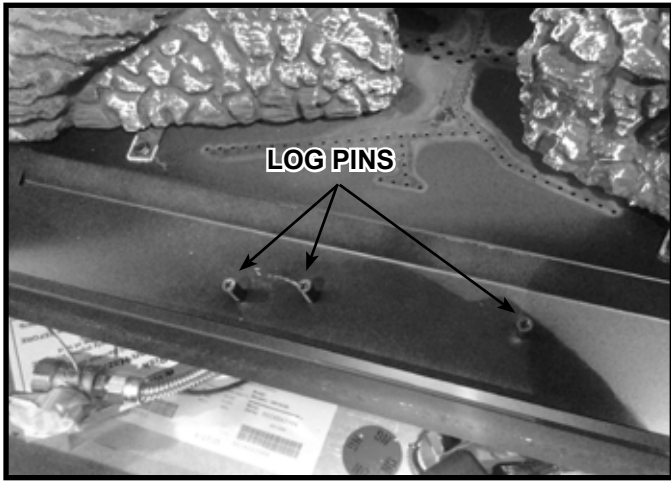

Figure 4. Log Pin Locations

Log #5: Place Log #5 into position. The forked end of Log #5 is positioned on the log pins as shown in Figure 5. The back end of Log #5 will rest on Log #4, but does not touch Log #1.

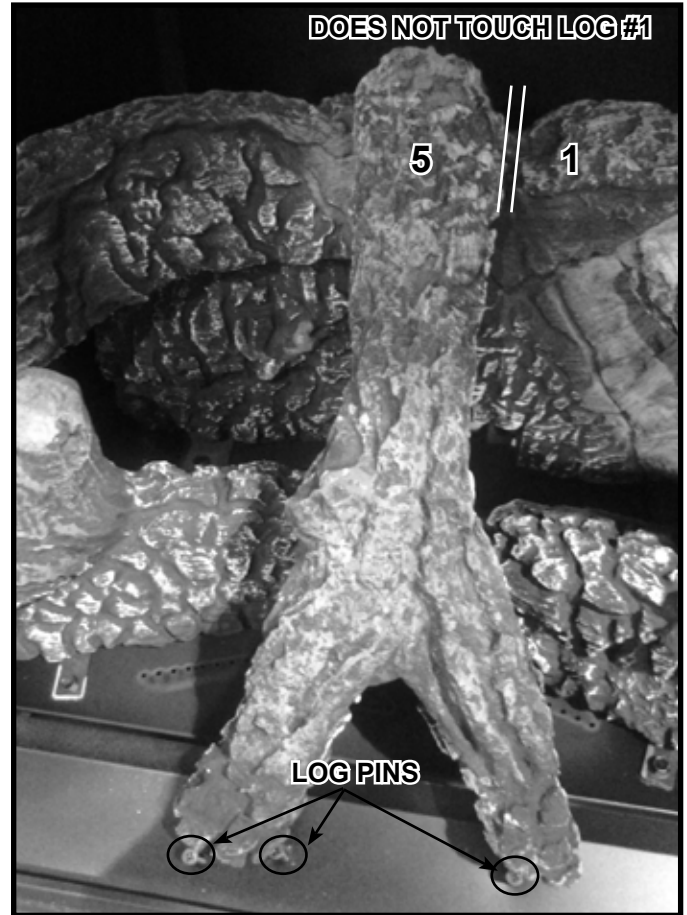

Figure 5. Log #5 in Position

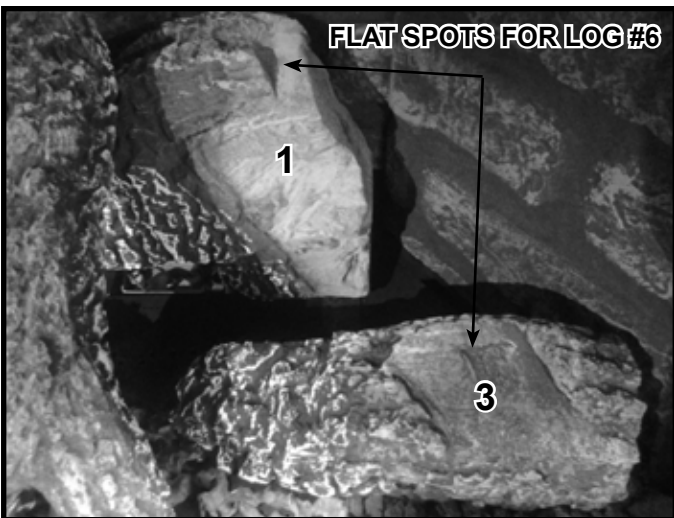

Figure 6. Locations of Flat Spots for Log #6

Log #6: Place Log #6 into position by setting the large end on the flat spot in Log #3 and then resting the small end on the flat spot on Log #1.



Figure 7. Log Set Installed

12 Reference Materials

→ A. Approved Vent Components List

Vent components on this list are approved for use with these models.

Scan QR code or click on the link to access document including dimensions and effective lengths of vent components.



[Vent Components](#)

DVP Vent Components			
DVP45	45 Degree Elbow	DVP-TVHW	Vertical Termination Cap (High Wind)
DVP-90ST	90 Degree Elbow	DVP-HPC	High Performance Cap
DVP-HVS	Vent Support	DVP-BEK2	DVP-HPC Cap Brick Extension
DVP-RDS	Roof Deck Insulation Shield	COOL-ADDM	Cap Shield
DVP-WS	Wall Shield Firestop	DVP-TB1	Basement Vent Cap
DVP-FS	Ceiling Firestop	DRC-RADIUS	Cap Shield
DVP-TRAP	Horizontal Termination Cap (DVP-TRAP1/2/K1/K2/HPC1/HPC2)	DVP-HRC-SS	High Rise Cap
RF6 / RF12	Roof Flashings	DVP-HRC-ZC-SS	Zero Clearance High Rise Cap
DVP-TRAPFL	Flashing	TRAP-VSS	Extended Heat Shield
DVP-HSM-B	Extended Heat Shield	UNIV-AS2	Universal Attic Shield
DVP-TV	Vertical Termination Cap		
SLP Vent Components			
SLP45	45 Degree Elbow	SLP-CCS-BK	Cathedral Ceiling Support Box-Black
SLP90	90 Degree Elbow	SLP-DCF-BK	Ceiling Firestop Black
DVP-SLP24	Adapter	SLP-WT-BK	Wall Thimble Black
SLK-SNKD	Snorkel Termination Cap	SLP-RDS	Roof Deck Insulation Shield
SLP-TVHW	Vertical Termination Cap	SLP-FS	Ceiling Firestop
SLP-TB1	Basement Vent Cap	SLP-WS	Wall Shield Firestop
SLP-HVS	Horizontal Pipe Support	DVP-2SL	Adapter
SLP-TRAP	Horizontal Termination Cap (TRAP1/2)	DVP-HSM-B	Extended Heat Shield
SL-2DVP	Adapter	SLP-HRC-SS	Horizontal Termination Cap
Power Vent Components			
PVV-SLP	Vertical Power Vent	PVLP-SLP	Power Vent Low Profile
PVI-SLP-B	Power Vent Inline	SLP-LPC	SLP Low Profile Cap
Decorative Terminations / Shrouds			
Only use listed decorative termination caps/shrouds with Hearth & Home Technologies approved venting systems. This applies to both DVP and SLP venting systems.			
DTO134	Octagon Decor Cap	LDS33	Decor Shroud 36 x 36
DTO146	Octagon Decor Cap	LDS46	Decor Shroud 48 x 72
DTS134	Square Decor Cap	LDS-BV	Decor Shroud 26 x 26
DTS146	Square Decor Cap		

B. Optional Components

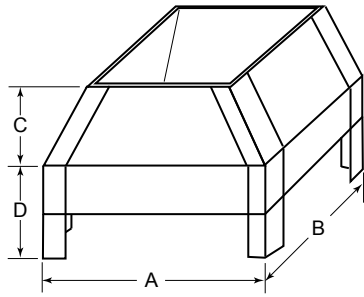

LDS33/LDS46 Decorative Shroud

Catalog #	A		B		C		D	
	in.	mm	in.	mm	in.	mm	in.	mm
LDS33	36	914	36	914	8.5	216	11	279
LDS46	48	1219	72	1829	8.5	216	11	279

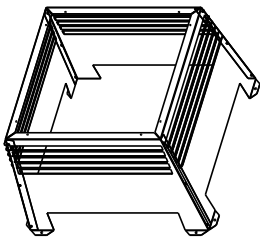

LDS-BV Decorative Shroud

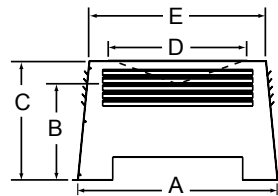

Catalog #		A	B	C	E	E
LDS-BV	in.	26	12.5	15.5	21	23
	mm	660	318	394	533	584

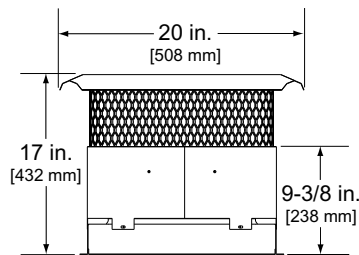

TCG375 Terra Cotta Cap

LDSCP-M Shroud Leg Multipack
(not shown)

See your Heatilator dealer for a complete listing of optional components.

C. Accessories

Install approved accessories per instructions included with accessories. Contact your dealer for a list of approved accessories.

WARNING! Risk of Fire and Electric Shock! Use ONLY Hearth & Home Technologies-approved optional accessories with this appliance. Using non-listed accessories could result in a safety hazard and will void the warranty.

Remote Controls, Wall Controls and Wall Switches

After a qualified service technician has installed the remote control, wall control or wall switch, follow the instructions supplied with the control installed to operate your appliance:

For safety:

- Install a switch lock or a wall/remote control with child protection lockout feature.
- Keep remote controls out of reach of children.

Contact your dealer if you have questions.

IntelliFire Wi-Fi Module with IntelliFire App

After a qualified service technician has installed the Wi-Fi module with IntelliFire app, follow the instructions supplied with the control installed to operate your appliance. Contact your dealer if you have questions.

Factory-Installed Fan

The NNXT models include a factory-installed fan. Follow the instructions included with the appliance remote control to operate the fan. Contact your dealer if you have questions.

Optional Heat Management Systems Kits

After a qualified service technician has installed the heat management system, follow the instructions supplied with the kit for operation. Contact your dealer if you have questions.

Note: Optional heat management systems kit must be installed while the sides of the appliance are accessible.

Heatilator, a brand of Hearth & Home Technologies
7571 215th Street West, Lakeville, MN 55044
www.heatilator.com

Please contact your Heatilator dealer with any questions or concerns.

For the location of your nearest Heatilator dealer,
please visit www.heatilator.com.

Printed in U.S.A. - Copyright 2024