

# Installation Manual

## Installation and Appliance Setup

This appliance has been retired.  
For replacement parts, please refer to the individual  
service parts list located on the brand websites.

**INSTALLER:** Leave this manual with party responsible for use and operation.  
**OWNER:** Retain this manual for future reference.

**NOTICE:** DO NOT discard this manual!

**HEAT & GLO™**

No one builds a better fire

**Models:** **GAS-FIRED**

**RED60-NNN**

**RED60-NM**

**RED60-LM**

**RED60-NNN-80**

**RED60-NM-80**

**RED60-LM-80**

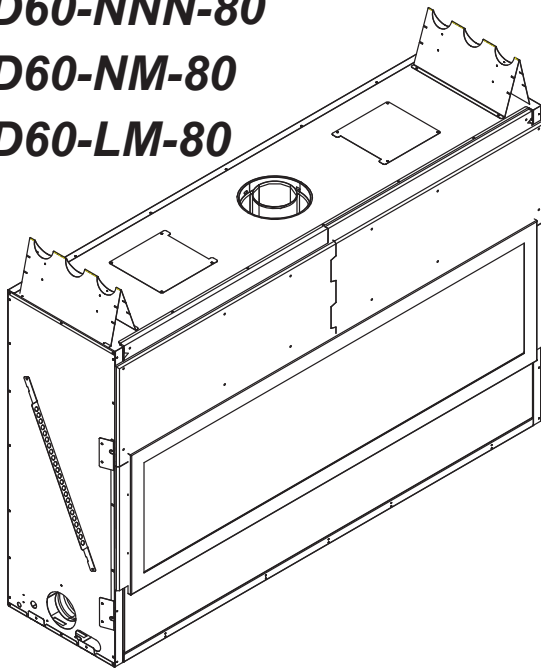

This appliance may be installed as an OEM installation in manufactured home (USA only) or mobile home and must be installed in accordance with the manufacturer's instructions and the *Manufactured Home Construction and Safety Standard, Title 24 CFR, Part 3280* in the United States, or the *Standard for Installation in Mobile Homes, CAN/CSA Z240 MH Series*, in Canada.

This appliance is only for use with the type(s) of gas indicated on the rating plate. This appliance is not convertible for use with other gases, unless a certified kit is used.

**⚠ WARNING:**  
**FIRE OR EXPLOSION HAZARD**  
Failure to follow safety warnings exactly could result in serious injury, death, or property damage.

- **DO NOT** store or use gasoline or other flammable vapors and liquids in the vicinity of this or any other appliance.
- **What to do if you smell gas**
  - **DO NOT** try to light any appliance.
  - **DO NOT** touch any electrical switch. **DO NOT** use any phone in your building.
  - Leave the building immediately.
  - Immediately call your gas supplier from a neighbor's phone. Follow the gas supplier's instructions.
  - If you cannot reach your gas supplier, call the fire department.
- Installation and service must be performed by a qualified installer, service agency, or the gas supplier.

**⚠ DANGER**



**HOT GLASS WILL  
CAUSE BURNS.**

**DO NOT TOUCH GLASS  
UNTIL COOLED.**

**NEVER ALLOW CHILDREN  
TO TOUCH GLASS.**

A barrier designed to reduce the risk of burns from the hot viewing glass is provided with this appliance and shall be installed for the protection of children and other at-risk individuals.

In the Commonwealth of Massachusetts installation must be performed by a licensed plumber or gas fitter.  
See Table of Contents for location of additional Commonwealth of Massachusetts requirements.

## ▲ Safety Alert Key:

- **DANGER!** Indicates a hazardous situation which, if not avoided will result in death or serious injury.
- **WARNING!** Indicates a hazardous situation which, if not avoided could result in death or serious injury.
- **CAUTION!** Indicates a hazardous situation which, if not avoided, could result in minor or moderate injury.
- **NOTICE:** Used to address practices not related to personal injury.

## Table of Contents

Installation Standard Work Checklist . . . . .	3	<b>7 Venting and Chimneys</b>	
<b>1 Product Specific and Important Safety Information</b>		A. Assemble Vent Sections . . . . .	45
A. Appliance Certification . . . . .	4	B. Assemble Slip Sections . . . . .	46
B. Glass Specifications . . . . .	4	C. Secure The Vent Sections . . . . .	46
C. BTU Specifications . . . . .	4	D. Disassemble Vent Sections . . . . .	47
D. High Altitude Installations . . . . .	4	E. Vertical Termination Requirements . . . . .	48
E. Non-Combustible Materials Specification . . . . .	4	F. Horizontal Termination Requirements . . . . .	49
F. Combustible Materials Specification . . . . .	4	<b>8 Electrical Information</b>	
G. Electrical Codes . . . . .	4	A. General Information . . . . .	51
H. Requirements for the Commonwealth of Massachusetts . . . . .	5	B. Wiring Requirements . . . . .	52
<b>2 Getting Started</b>		C. Optional LED Lighting Circuit . . . . .	55
A. Design and Installation Considerations . . . . .	6	D. Active Convection Blower Replacement . . . . .	56
B. Tools and Supplies Needed . . . . .	6	<b>9 Gas Information</b>	
C. Inspect Appliance and Components . . . . .	6	A. Fuel Conversion . . . . .	59
<b>3 Framing and Clearances</b>		B. Gas Pressure . . . . .	59
A. Appliance/Decorative Dimension Diagram . . . . .	7	C. Gas Connection . . . . .	60
B. Clearances to Combustibles . . . . .	9	D. High Altitude Installations . . . . .	60
C. Constructing the Appliance Chase . . . . .	10	E. Air Shutter Setting . . . . .	61
D. Floor Protection . . . . .	10	<b>10 Finishing</b>	
<b>4 Termination Location and Vent Information</b>		A. Facing and Finishing Instructions . . . . .	62
A. Vent Termination Minimum Clearances . . . . .	12	B. Mantel and Wall Projections . . . . .	65
B. Chimney Diagram . . . . .	13	C. Mesh Fronts . . . . .	66
C. Approved Pipe . . . . .	14	<b>11 Appliance Setup</b>	
D. Use of Elbows . . . . .	14	A. Fixed Glass Assembly . . . . .	67
E. Measuring Standards . . . . .	14	B. Remove the Shipping Materials . . . . .	67
F. Vent Information . . . . .	14	C. Clean the Appliance . . . . .	67
→ G. Installation Instructions and Venting Information		D. Accessories . . . . .	67
- PVI-DVP . . . . .	15	E. Rock Media Instructions . . . . .	68
H. Vent Diagrams . . . . .	22	F. Porcelain Instructions . . . . .	70
I. Installation Instructions and Venting Information		G. Granite Instructions . . . . .	75
- PVK-80 for RED60 Model . . . . .	30	H. Sheet Metal Refractory Instructions . . . . .	78
<b>5 Vent Clearances and Framing</b>		I. Install the Mesh . . . . .	80
A. Pipe Clearances to Combustibles . . . . .	40	<b>12 Reference Materials</b>	
B. Wall Penetration Framing . . . . .	40	A. Vent Components Diagrams . . . . .	81
C. Ceiling Firestop/Floor Penetration Framing . . . . .	41	B. Accessories . . . . .	85
D. Install Attic Insulation Shield . . . . .	41		
<b>6 Appliance Preparation</b>			
A. Vent Collar Preparation . . . . .	42		
B. Securing and Leveling the Appliance . . . . .	43		
C. Active Convection Technology . . . . .	44		

→ = Contains updated information.

# Installation Standard Work Checklist

## ATTENTION INSTALLER: Follow this Standard Work Checklist

This standard work checklist is to be used by the installer in conjunction with, not instead of, the instructions contained in this installation manual.

**Customer:** \_\_\_\_\_  
**Lot/Address:** \_\_\_\_\_  
**Model (circle one):** RED60

**Date Installed:** \_\_\_\_\_  
**Location of Fireplace:** \_\_\_\_\_  
**Installer:** \_\_\_\_\_  
**Dealer/Distributor Phone #** \_\_\_\_\_  
**Serial #:** \_\_\_\_\_



**WARNING! Risk of Fire or Explosion!** Failure to install appliance according to these instructions can lead to a fire or explosion.

**Appliance Install Sections 3 and 6**

	YES	IF NO, WHY?
Verified that the chase is insulated and sealed. (Pg. 10)	<input type="checkbox"/>	_____
Required factory-installed non-combustible board is in place.	<input type="checkbox"/>	_____
Verified clearances to combustibles. (Pg. 9)	<input type="checkbox"/>	_____
Fireplace is leveled and secured. (Pg. 43)	<input type="checkbox"/>	_____

**Venting/Chimney Sections 4,5 and 7**

Venting configuration complies to vent diagrams. (Section 4)	<input type="checkbox"/>	_____
Venting installed, locked and secured in place with proper clearance.	<input type="checkbox"/>	_____
Firestops installed. (Section 5)	<input type="checkbox"/>	_____
Attic insulation shield installed. (Pg 41)	<input type="checkbox"/>	_____
Exterior wall/Roof flashing installed and sealed. (Section 7)	<input type="checkbox"/>	_____
Terminations installed and sealed. (Section 7)	<input type="checkbox"/>	_____
Vacuum switch is in correct orientation. (Pg 20-21)	<input type="checkbox"/>	_____

**Electrical Section 8 (Pg 51-58)**

Unswitched power (110-120 VAC) provided to the appliance.	<input type="checkbox"/>	_____
Switch wires properly installed.	<input type="checkbox"/>	_____

**Gas Section 9 (Pg 59-61)**

Proper appliance for fuel type.	<input type="checkbox"/>	_____
Was a conversion performed?	<input type="checkbox"/>	_____
Leak check performed and inlet pressure verified.	<input type="checkbox"/>	_____
Verified proper air shutter setting for installation type.	<input type="checkbox"/>	_____

**Finishing Section 10 (Pg 62-66)**

Combustible materials not installed in non-combustible areas.	<input type="checkbox"/>	_____
Verified all clearances meet installation manual requirements.	<input type="checkbox"/>	_____
Mantels and wall projections comply with installation manual requirements.	<input type="checkbox"/>	_____

**Appliance Setup Section 11 (Pg 67-80)**

All packaging and protective materials removed (inside & outside of appliance).	<input type="checkbox"/>	_____
Refractories and media installed correctly.	<input type="checkbox"/>	_____
Glass assembly installed and secured.	<input type="checkbox"/>	_____
Accessories installed properly.	<input type="checkbox"/>	_____
Mesh, doors, or decorative front properly installed.	<input type="checkbox"/>	_____
Manual bag and all of its contents are removed from inside/under the appliance and given to party responsible for use and operation.	<input type="checkbox"/>	_____
Started appliance and verified no gas leaks exist.	<input type="checkbox"/>	_____
Lights work in all switched positions (if so equipped).	<input type="checkbox"/>	_____

**Hearth & Home Technologies recommends the following:**

- Photographing the installation and copying this checklist for your file.
- That this checklist remain visible at all times on the appliance until the installation is complete.

**Comments:** Further description of the issues, who is responsible (Installer/ Builder/ Other Trades, etc) and corrective action needed \_\_\_\_\_

Comments Communicated to party responsible \_\_\_\_\_ by \_\_\_\_\_ on \_\_\_\_\_  
 (Builder / Gen. Contractor/) (Installer) (Date)

➔ = Contains updated information.

2159-982 Rev. E 12/14

# 1 Product Specific and Important Safety Information

## A. Appliance Certification

**MODEL:** RED60-NNN, RED60-NM, RED60-LM,  
 RED60-NNN-80, RED60-NM-80, RED60-LM-80  
**LABORATORY:** Underwriters Laboratories, Inc. (UL)  
**TYPE:** Direct Vent Heater  
**STANDARD:** ANSI Z21.88-2014/CSA 2.33-2014  
 Vented Gas Fireplace Heaters

This product is listed to ANSI standards for “Vented Gas Fireplace Heaters” and applicable sections of “Gas Burning Heating Appliances for Manufactured Homes and Recreational Vehicles”, and “Gas Fired Appliances for Use at High Altitudes”.

**NOTICE:** This installation must conform with local codes. In the absence of local codes you must comply with the National Fuel Gas Code, ANSI Z223.1-latest edition in the U.S.A. and the CAN/CGA B149 Installation Codes in Canada.

**NOT INTENDED FOR USE AS A PRIMARY HEAT SOURCE.**

This appliance is tested and approved as either supplemental room heat or as a decorative appliance. It should not be factored as primary heat in residential heating calculations.

## B. Glass Specifications

Hearth & Home Technologies appliances manufactured with tempered glass may be installed in hazardous locations such as bathtub enclosures as defined by the Consumer Product Safety Commission (CPSC). The tempered glass has been tested and certified to the requirements of **ANSI Z97.1** and **CPSC 16 CFR 1202** (Safety Glazing Certification Council **SGCC# 1595** and **1597**. Architectural Testing, Inc. Reports **02-31919.01** and **02-31917.01**).

This statement is in compliance with **CPSC 16 CFR Section 1201.5** “Certification and labeling requirements” which refers to **15 U.S. Code (USC) 2063** stating “...Such certificate shall accompany the product or shall otherwise be furnished to any distributor or retailer to whom the product is delivered.”

Some local building codes require the use of tempered glass with permanent marking in such locations. Glass meeting this requirement is available from the factory. Please contact your dealer or distributor to order.

## C. BTU Specifications

Models (U.S. or Canada)	Maximum Input BTU/h	Minimum Input BTU/h	Orifice Size (DMS)
RED60-NNN RED60-NM RED60-LM US (0-2000 FT)	44,000	31,000	#30
RED60-NNN-80 RED60-NM-80 RED60-LM-80 CANADA (2000-4500 FT) (NG)	39,500	28,000	#32
RED60-NNN RED60-NM RED60-LM US (0-2000 FT)	43,000	35,000	#47
RED60-NNN-80 RED60-NM-80 RED60-LM-80 CANADA (2000-4500 FT) (PROPANE)	38,500	31,500	#48

## D. High Altitude Installations

**NOTICE:** If the heating value of the gas has been reduced, these rules do not apply. Check with your local gas utility or authorities having jurisdiction.

When installing above 2000 feet elevation:

- In the USA: Reduce input rate 4% for each 1000 feet above 2000 feet.
- In CANADA: Reduce input rate 10% for elevations between 2000 feet and 4500 feet. Above 4500 feet, consult local gas utility.

Check with your local gas utility to determine proper orifice size.

## E. Non-Combustible Materials Specification

Material which will not ignite and burn. Such materials are those consisting entirely of steel, iron, brick, tile, concrete, slate, glass or plasters, or any combination thereof.

Materials that are reported as passing **ASTM E 136, Standard Test Method for Behavior of Materials in a Vertical Tube Furnace at 750 °C** shall be considered non-combustible materials.

## F. Combustible Materials Specification

Materials made of or surfaced with wood, compressed paper, plant fibers, plastics, or other material that can ignite and burn, whether flame proofed or not, or plastered or unplastered shall be considered combustible materials.

## G. Electrical Codes

**NOTICE:** This appliance must be electrically wired and grounded in accordance with local codes or, in the absence of local codes, with **National Electric Code ANSI/NFPA 70-latest edition or the Canadian Electric Code CSA C22.1**.

- A 110-120 VAC circuit for this product must be protected with ground-fault circuit-interrupter protection, in compliance with the applicable electrical codes, when it is installed in locations such as in bathrooms or near sinks.



**Note:** The following requirements reference various Massachusetts and national codes not contained in this document.

## H. Requirements for the Commonwealth of Massachusetts

For all side wall horizontally vented gas fueled equipment installed in every dwelling, building or structure used in whole or in part for residential purposes, including those owned or operated by the Commonwealth and where the side wall exhaust vent termination is less than seven (7) feet above finished grade in the area of the venting, including but not limited to decks and porches, the following requirements shall be satisfied:

### Installation of Carbon Monoxide Detectors

At the time of installation of the side wall horizontal vented gas fueled equipment, the installing plumber or gas fitter shall observe that a hard wired carbon monoxide detector with an alarm and battery back-up is installed on the floor level where the gas equipment is to be installed. In addition, the installing plumber or gas fitter shall observe that a battery operated or hard wired carbon monoxide detector with an alarm is installed on each additional level of the dwelling, building or structure served by the side wall horizontal vented gas fueled equipment. It shall be the responsibility of the property owner to secure the services of qualified licensed professionals for the installation of hard wired carbon monoxide detectors.

In the event that the side wall horizontally vented gas fueled equipment is installed in a crawl space or an attic, the hard wired carbon monoxide detector with alarm and battery back-up may be installed on the next adjacent floor level.

In the event that the requirements of this subdivision can not be met at the time of completion of installation, the owner shall have a period of thirty (30) days to comply with the above requirements; provided, however, that during said thirty (30) day period, a battery operated carbon monoxide detector with an alarm shall be installed.

### Approved Carbon Monoxide Detectors

Each carbon monoxide detector as required in accordance with the above provisions shall comply with NFPA 720 and be ANSI/UL 2034 listed and IAS certified.

### Signage

A metal or plastic identification plate shall be permanently mounted to the exterior of the building at a minimum height of eight (8) feet above grade directly in line with the exhaust vent terminal for the horizontally vented gas fueled heating appliance or equipment. The sign shall read, in print size no less than one-half (1/2) in. in size, **“GAS VENT DIRECTLY BELOW. KEEP CLEAR OF ALL OBSTRUCTIONS”**.

## Inspection

The state or local gas inspector of the side wall horizontally vented gas fueled equipment shall not approve the installation unless, upon inspection, the inspector observes carbon monoxide detectors and signage installed in accordance with the provisions of 248 CMR 5.08(2)(a)1 through 4.

## Exemptions

The following equipment is exempt from 248 CMR 5.08(2)(a)1 through 4:

- The equipment listed in Chapter 10 entitled “Equipment Not Required To Be Vented” in the most current edition of NFPA 54 as adopted by the Board; and
- Product Approved side wall horizontally vented gas fueled equipment installed in a room or structure separate from the dwelling, building or structure used in whole or in part for residential purposes.

## MANUFACTURER REQUIREMENTS

### Gas Equipment Venting System Provided

When the manufacturer of Product Approved side wall horizontally vented gas equipment provides a venting system design or venting system components with the equipment, the instructions provided by the manufacturer for installation of the equipment and the venting system shall include:

- Detailed instructions for the installation of the venting system design or the venting system components; and
- A complete parts list for the venting system design or venting system.

### Gas Equipment Venting System NOT Provided

When the manufacturer of a Product Approved side wall horizontally vented gas fueled equipment does not provide the parts for venting the flue gases, but identifies “special venting systems”, the following requirements shall be satisfied by the manufacturer:

- The referenced “special venting system” instructions shall be included with the appliance or equipment installation instructions; and
- The “special venting systems” shall be Product Approved by the Board, and the instructions for that system shall include a parts list and detailed installation instructions.

A copy of all installation instructions for all Product Approved side wall horizontally vented gas fueled equipment, all venting instructions, all parts lists for venting instructions, and/or all venting design instructions shall remain with the appliance or equipment at the completion of the installation.

**See Gas Connection section for additional Commonwealth of Massachusetts requirements.**

# 2 Getting Started

## A. Design and Installation Considerations

Heat & Glo direct vent gas appliances are designed to operate with all combustion air siphoned from outside of the building and all exhaust gases expelled to the outside. No additional outside air source is required.

Installation MUST comply with local, regional, state and national codes and regulations. Consult insurance carrier, local building inspector, fire officials or authorities having jurisdiction over restrictions, installation inspection and permits.

**NOTICE:** *The blower motor present in this appliance will generate sound during operation. The effects of the increased sound level can be minimized with careful planning during installation of the system. Locating the convection intake grill in an area remote of immediate living space will reduce the effects of the added sound generated during operation.*

Before installing, determine the following:

- Where the appliance is to be installed.
- The vent system configuration to be used.
- Gas supply piping.
- Electrical wiring requirements.
- Framing and finishing details.
- Where wall switch is to be located.

Improper installation, adjustment, alteration, service or maintenance can cause injury or property damage. For assistance or additional information, consult a qualified service technician, service agency or your dealer.



Installation and service of this appliance should be performed by qualified personnel. Hearth & Home Technologies suggests NFI certified or factory trained professionals, or technicians supervised by an NFI certified professional ([www.nficertified.org](http://www.nficertified.org)).

Improper installation, adjustment, alteration, service or maintenance can cause injury or property damage. For assistance or additional information, consult a qualified service technician, service agency or your dealer.

## B. Tools and Supplies Needed

Before beginning the installation be sure that the following tools and building supplies are available.

- |  |  |
|--|--|
| Tape measure   | Framing material                           |
| Pliers   | Non-corrosive leak check solution          |
| Hammer   | Phillips screwdriver (magnetic)            |
| Gloves   | Framing square                             |
| Voltmeter  | Electric drill and bits (1/4 in. magnetic) |
| Plumb line   | Safety glasses                             |
| Level  | Reciprocating saw                          |
| Manometer  | Flat blade screwdriver                     |
| 1/2 - 3/4 in. length, #6 or #8 Self-drilling screws          |  |
| Caulking material (300°F minimum continuous exposure rating) |  |
| One 1/4 in. female connection (for optional blower).         |  |

## C. Inspect Appliance and Components

- Carefully remove the appliance and components from the packaging.
- The vent system components and decorative doors and fronts may be shipped in separate packages.
- Report to your dealer any parts damaged in shipment, particularly the condition of the glass.
- **Read all of the instructions before starting the installation. Follow these instructions carefully during the installation to ensure maximum safety and benefit.**

**WARNING! Risk of Fire or Explosion!** *Damaged parts could impair safe operation. DO NOT install damaged, incomplete or substitute components. Keep appliance dry.*

Hearth & Home Technologies disclaims any responsibility for, and the warranty will be voided by, the following actions:

- Installation and use of any damaged appliance or vent system component.
- Modification of the appliance or vent system.
- Installation other than as instructed by Hearth & Home Technologies.
- Improper positioning of the glass door.
- Installation and/or use of any component part not approved by Hearth & Home Technologies.

**Any such action may cause a fire hazard.**

**WARNING! Risk of Fire, Explosion or Electric Shock!** *DO NOT use this appliance if any part has been under water. Call a qualified service technician to inspect the appliance and to replace any part of the control system and/or gas control which has been under water.*

# 3 Framing and Clearances

## A. Appliance/Decorative Dimension Diagram

Dimensions are actual appliance dimensions. Use for reference only. For framing dimensions and clearances refer to Section 5.

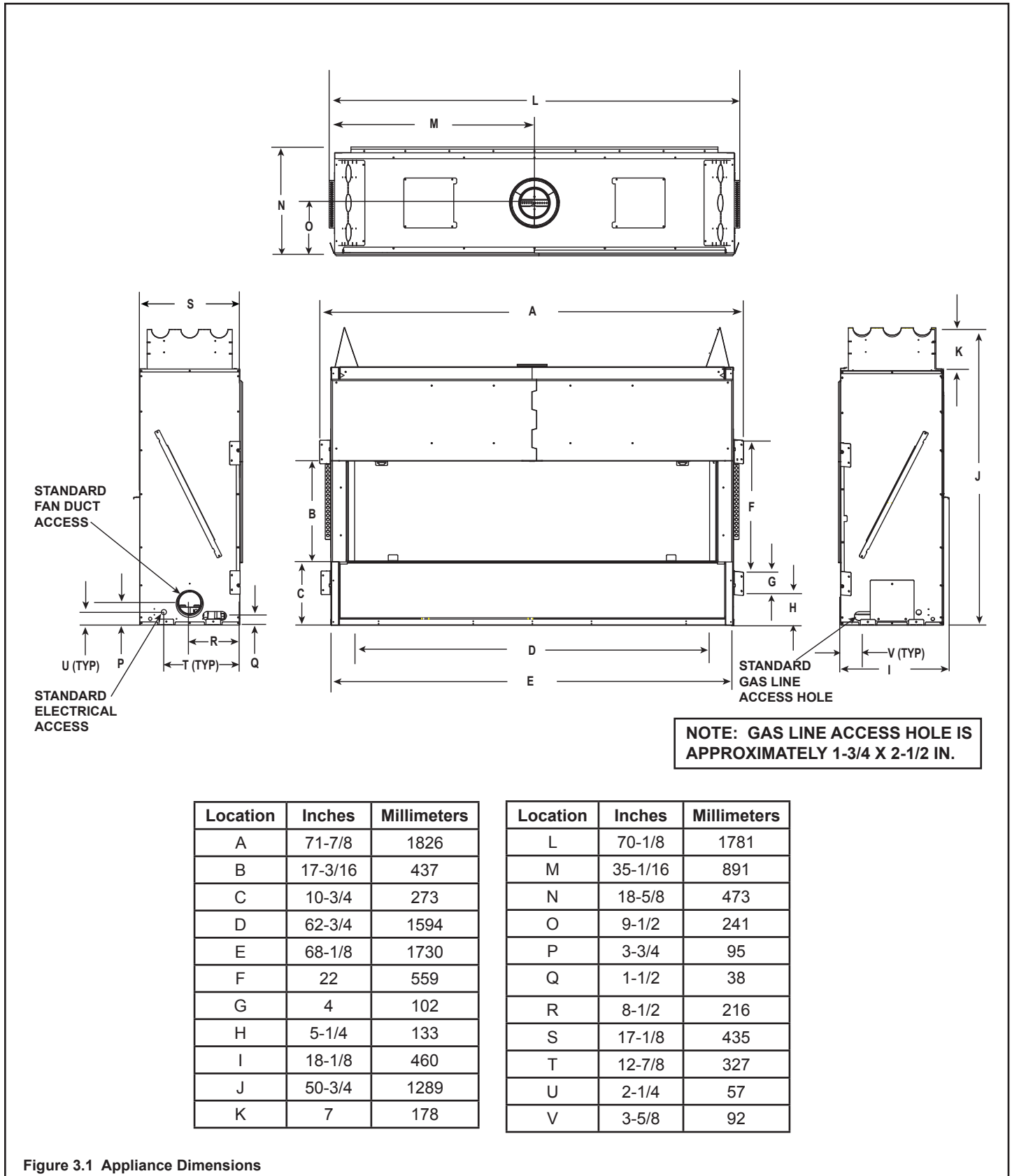
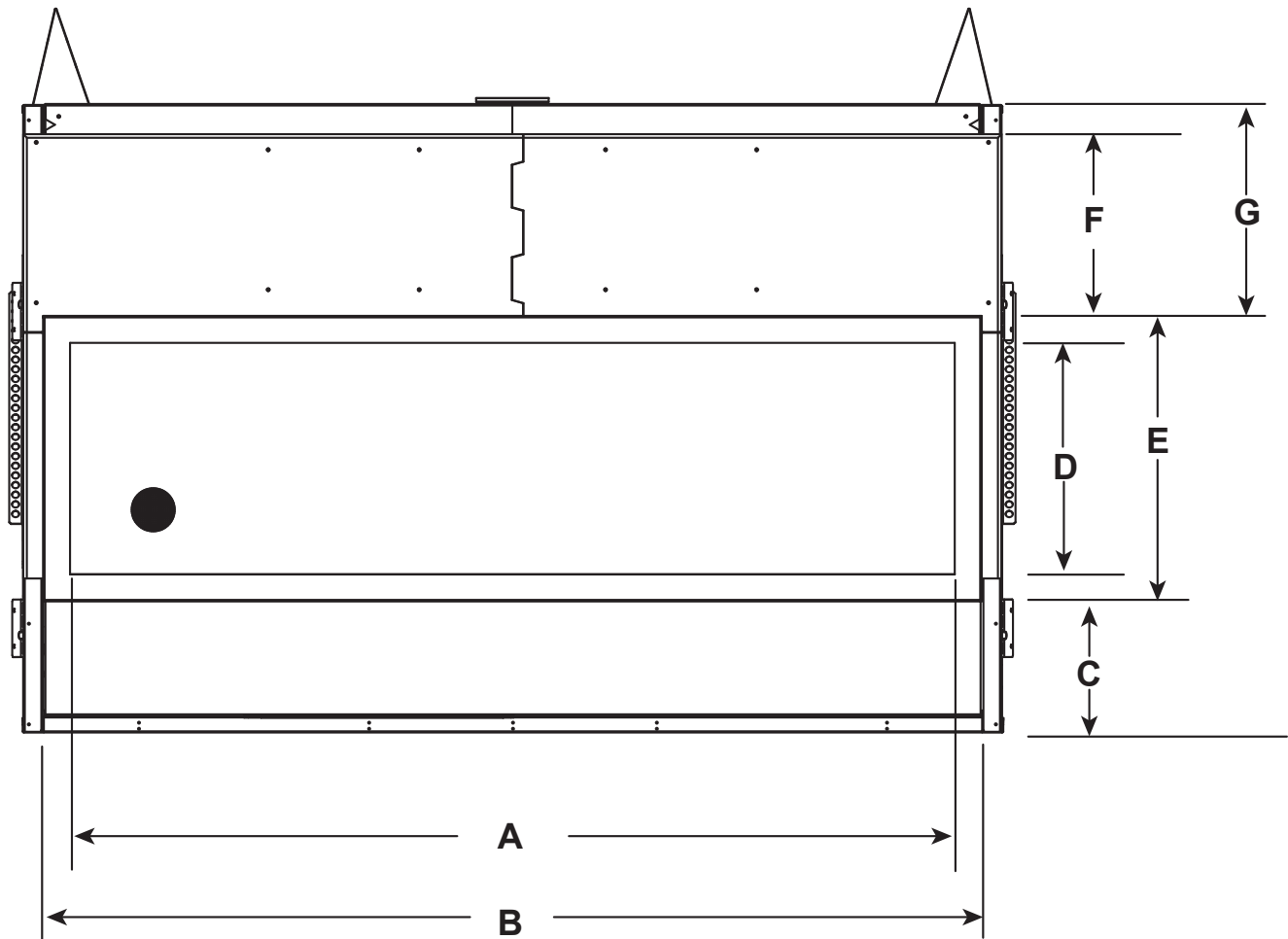

Figure 3.1 Appliance Dimensions

# SRV2159-040 DECORATIVE FRONT



Location	Inches	Millimeters
A	61-1/2	1562
B	65-1/4	1657
C	9-1/16	230
D	16-1/8	409
E	19-7/8	504
F	12-5/8	321
G	14-3/4	374

Figure 3.2 Decorative Front Dimensions



## B. Clearances to Combustibles

When selecting a location for the appliance it is important to consider the required clearances to walls (see Figure 3.3).

**WARNING! Risk of Fire or Burns!** Provide adequate clearance around air openings and for service access. Due to high temperatures, the appliance should be located out of traffic and away from furniture and draperies.

**NOTICE:** Illustrations reflect typical installations and are FOR DESIGN PURPOSES ONLY. Illustrations/diagrams are not drawn to scale. Actual installation may vary due to individual design preference.

It is important to follow the framing and finishing instructions step by step to ensure proper placement of fireplace in the surrounding framing/finishing materials. For additional information and considerations for the active convection technology in regards to appliance location and framing, see Section 6.

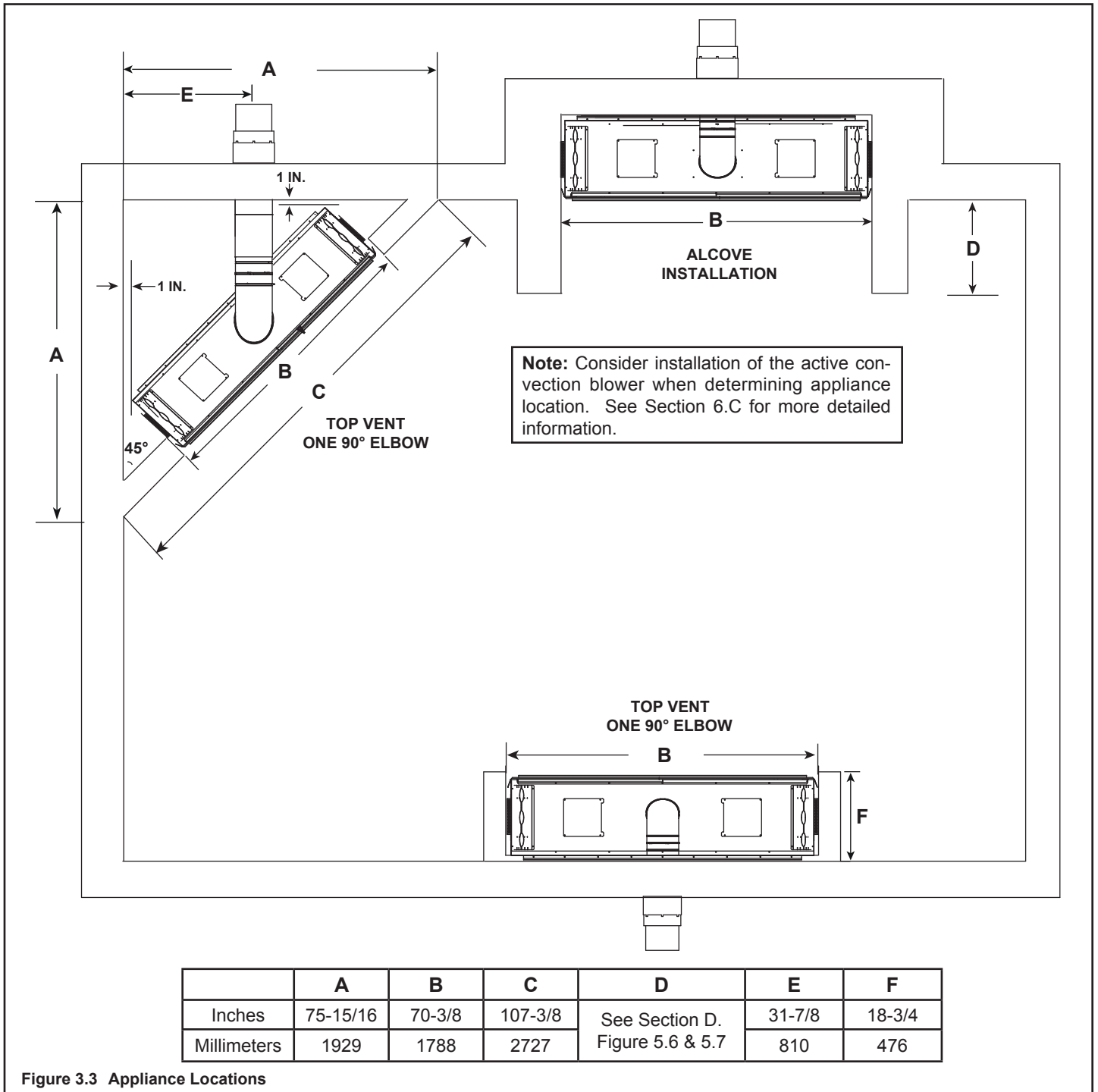

Figure 3.3 Appliance Locations

## C. Constructing the Appliance Chase

A chase is a vertical box-like structure built to enclose the gas appliance and/or its vent system. In cooler climates the vent should be enclosed inside the chase.

**NOTICE:** Treatment of ceiling firestops and wall shield firestops and construction of the chase may vary with the type of building. These instructions are not substitutes for the requirements of local building codes. Therefore, you **MUST** check local building codes to determine the requirements to these steps.

Chases should be constructed in the manner of all outside walls of the home to prevent cold air drafting problems. The chase should not break the outside building envelope in any manner.

Walls, ceiling, base plate and cantilever floor of the chase should be insulated. Vapor and air infiltration barriers should be installed in the chase as per regional codes for the rest of the home. Additionally, in regions where cold air infiltration may be an issue, the inside surfaces may be sheetrocked and taped for maximum air tightness.

To further prevent drafts, the wall shield and ceiling firestops should be caulked with caulk with a minimum of 300°F continuous exposure rating to seal gaps. Gas line holes and other openings should be caulked with caulk with a minimum of 300°F continuous exposure rating or stuffed with unfaced insulation. If the appliance is being

installed on a cement surface, a layer of plywood may be placed underneath to prevent conducting cold up into the room.

## D. Floor Protection

**NOTICE:** Install appliance on hard metal or wood surfaces extending full width and depth. **DO NOT** install directly on carpeting, vinyl, tile or any combustible material other than wood.

**WARNING! Risk of Fire!** Maintain specified air space clearances to appliance and vent pipe:

- Insulation and other materials must be secured to prevent accidental contact.
- The chase must be properly blocked to prevent blown insulation or other combustibles from entering and making contact with fireplace or chimney.
- Failure to maintain airspace may cause overheating and a fire.

**Note:** Figure 3.4 and Figure 3.5 show the fireplace installed on the floor. However, this fireplace can be elevated off the floor provided that the fireplace is properly supported by framing materials and the ceiling clearances are maintained.

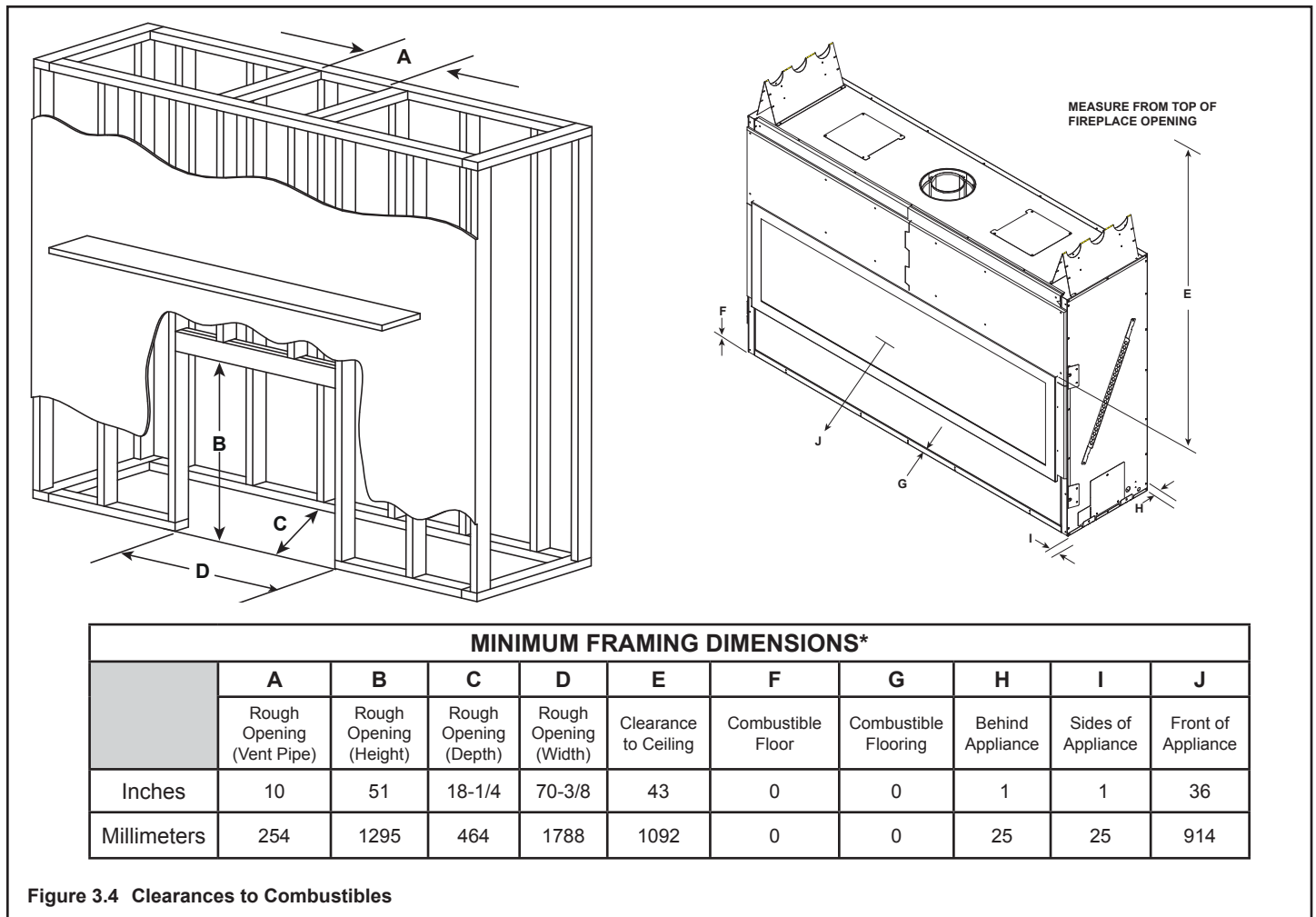
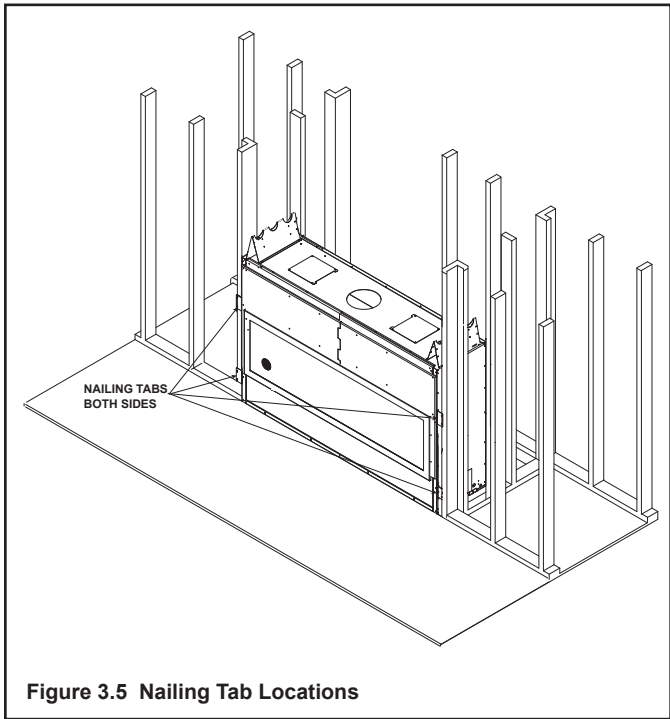

Figure 3.4 Clearances to Combustibles



**Figure 3.5 Nailing Tab Locations**

# 4 Termination Location and Vent Information

## A. Vent Termination Minimum Clearances

**WARNING**

Fire Risk.  
Maintain vent clearance to combustibles as specified.

- **DO NOT** pack air space with insulation or other materials.

Failure to keep insulation or other materials away from vent pipe could cause overheating and fire.

Roof Pitch	H (Min.) Ft.
Flat to 6/12.....	1.0*
Over 6/12 to 7/12.....	1.25*
Over 7/12 to 8/12.....	1.5*
Over 8/12 to 9/12.....	2.0*
Over 9/12 to 10/12.....	2.5*
Over 10/12 to 11/12.....	3.25
Over 11/12 to 12/12.....	4.0
Over 12/12 to 14/12.....	5.0
Over 14/12 to 16/12.....	6.0
Over 16/12 to 18/12.....	7.0
Over 18/12 to 20/12.....	7.5
Over 20/12 to 21/12.....	8.0

\* 3 foot minimum in snow regions

**Figure 4.1 Minimum Height From Roof To Lowest Discharge Opening**

A	B
6 in. (minimum) up to 20 in. <i>152 mm/508 mm</i>	18 in. minimum <i>457 mm</i>
20 in. and over	0 in. minimum

\* If using decorative cap cover(s), this distance may need to be increased. Refer to the installation instructions supplied with the decorative cap cover.

\*\* In a staggered installation with both gas and wood or fuel oil terminations, the wood or fuel oil termination cap must be higher than the gas termination cap.

**Figure 4.2 Staggered Termination Caps**

## B. Chimney Diagram

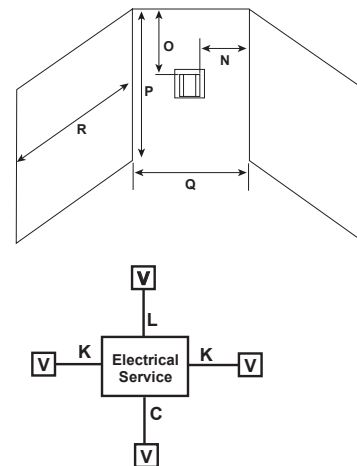
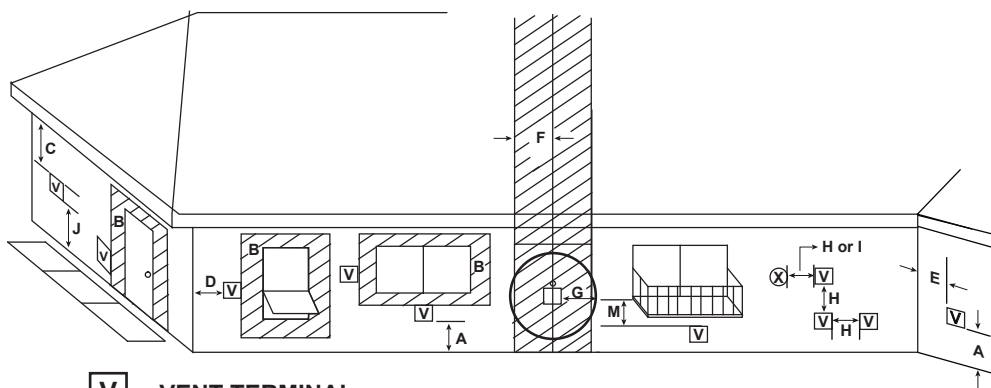

- = VENT TERMINAL
- = AIR SUPPLY INLET
- = AREA WHERE TERMINAL IS NOT PERMITTED

- A = 12 inches.....clearances above grade, veranda, porch, deck or balcony
- B = 9 inches.....clearance to window or door that may be opened, or to permanently closed window.
- C = 18 inches.....clearance below unventilated soffit  
18 inches.....clearance below ventilated soffit  
30 inches.....clearance below vinyl soffits and electrical service
- D = 6 inches.....clearance to outside corner
- E = 6 inches.....clearance to inside corner
- F = 3 ft. (Canada).....not to be installed above a gas meter/regulator assembly within 3 feet horizontally from the center-line of the regulator
- G = 3 ft.....clearance to gas service regulator vent outlet
- H = 12 inches.....clearance to non-mechanical (unpowered) air supply inlet, combustion air inlet or direct-vent termination
- i = 3 ft. (U.S.A.)  
6 ft. (Canada).....clearance to a mechanical (powered) air supply inlet

All mechanical air intakes within 10 feet of a termination cap must be a minimum of 3 feet below termination.

- J = 7 ft. .... On **public** property: clearance above paved sidewalk or a paved driveway.

A vent shall not terminate directly above a sidewalk or paved driveway which is located between two single family dwellings and serves both dwellings.

- K = 6 inches.....clearance from sides of electrical service
- L = 12 inches.....clearance above electrical service  
Location of the vent termination must not interfere with access to the electrical service.

- M = 18 inches .....clearance under veranda, porch, deck, balcony or overhang  
42 inches .....vinyl or composite overhang  
Permitted when veranda, porch, deck or balcony is fully open on a minimum of 2 sides beneath the floor.

### Covered Alcove Applications

(Spaces open only on one side and with an overhang)

- N = 6 inches ..... non-vinyl sidewalls  
12 inches ..... vinyl sidewalls
- O = 18 inches ..... non-vinyl soffit and overhang  
42 inches ..... vinyl soffit and overhang
- P = 8 ft.

	$Q_{MIN}$	$R_{MAX}$
1 cap	3 feet	$2 \times Q_{ACTUAL}$
2 caps	6 feet	$1 \times Q_{ACTUAL}$
3 caps	9 feet	$2/3 \times Q_{ACTUAL}$
4 caps	12 feet	$1/2 \times Q_{ACTUAL}$
$Q_{MIN} = \# \text{ termination caps} \times 3$ $R_{MAX} = (2 / \# \text{ termination caps}) \times Q_{ACTUAL}$		

Measure vertical clearances from this surface.

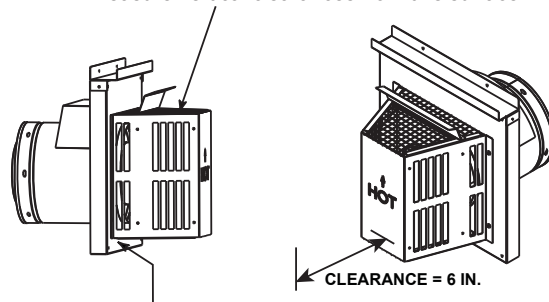

Measure horizontal clearances from this surface.

**CAUTION! Risk of Burns!** Termination caps are **HOT**. consider proximity to doors, traffic areas or where people may pass or gather (sidewalk, deck, patio, etc.). Listed cap shields available. Contact your dealer.

- Local codes or regulations may require different clearances.
- Vent system termination is **NOT** permitted in screened porches.
- Vent system termination is permitted in porch areas with two or more sides open.
- Hearth & Home Technologies assumes no responsibility for the improper performance of the appliance when the venting system does not meet these requirements.
- Vinyl protection kits are suggested for use with vinyl siding.

Figure 4.3 Minimum Clearances for Termination

## C. Approved Pipe

This appliance is approved for use with Hearth & Home Technologies DVP venting systems. Refer to Section 12.A for vent component information and dimensions.

**DO NOT** mix pipe, fittings or joining methods from different manufacturers.

The pipe is tested to be run inside an enclosed wall. There is no requirement for inspection openings at each joint within the wall.

**WARNING! Risk of Fire or Asphyxiation.** This appliance requires a separate vent. **DO NOT** vent to a pipe serving a separate solid fuel burning appliance.

## D. Use of Elbows

Diagonal runs have both vertical and horizontal vent aspects when calculating the effects. Use the rise for the vertical aspect and the run for the horizontal aspect.

Two 45° elbows may be used in place of one 90° elbow. On 45° runs, one foot of diagonal is equal to 8-1/2 in. (216 mm) horizontal run and 8-1/2 in. (216 mm) vertical run. A length of straight pipe is allowed between two 45° elbows. See Figure 4.4.

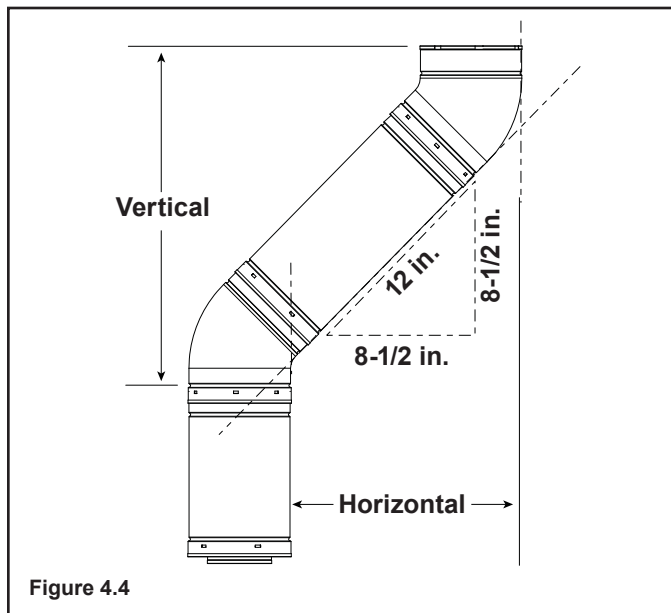

Figure 4.4

## E. Measuring Standards

Vertical and horizontal measurements listed in the vent diagrams were made using the following standards.

- Pipe measurements are shown using the effective length of pipe. See Section 12.A for information on effective length of pipe components.
- Measurements are made from the appliance outer wrap, not from the standoffs.
- Horizontal terminations are measured to the outside mounting surface (flange of termination cap). See Figure 4.3.
- Vertical terminations are measured to bottom of termination cap.
- Horizontal pipe installed level with no rise.

## F. Vent Information

General Rules:

- When penetrating a combustible wall, a wall shield firestop must be installed on each side of a combustible wall. See Section 5.B.
- When penetrating a combustible ceiling, a ceiling firestop must be installed.
- Horizontal runs of vent do not require vertical rise; horizontal runs may be level.
- Horizontal termination cap should have a 1/4 inch downward slant to allow any moisture in cap to be released.



## G. Installation Instructions and Venting Information - PVI-DVP

These instructions are for appliances utilizing the PVI-DVP. For appliances incorporating the PVK-80, see Section 4.I.

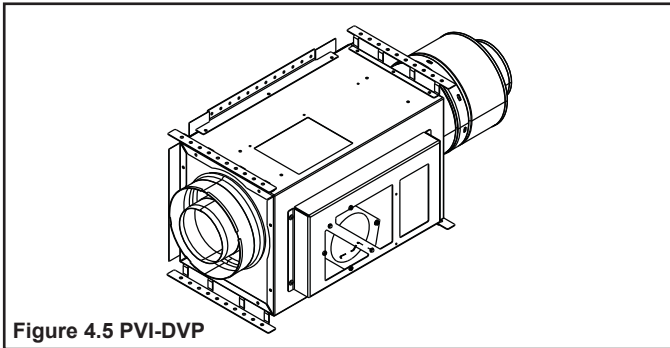

Figure 4.5 PVI-DVP

**IMPORTANT:** Failure to read and follow these instructions may create a possible hazard and will void the fireplace warranty.

**CAUTION! Risk of Cuts or Abrasions.** Wear protective gloves and safety glasses during installation. Sheet metal edges are sharp.

### INTRODUCTION

The PVI-DVP is certified for use only on fireplaces manufactured by Hearth & Home Technologies with IPI (intermittent pilot ignition) gas controls.

The PVI operates on 110-120 VAC electrical service which is supplied at the fireplace junction box.

### Components and Service Parts List

#### Service Parts List

Replacement parts can be obtained from your dealer. Repair of the Power Vent should only be done by a qualified service technician. A list of replacement parts is shown in the service parts section of this manual.

### INSTALLATION OF PVI-DVP

#### 1. INSTALLATION PRECAUTIONS

- This device must be installed by a qualified installer in accordance with these instructions.
- Safety inspection of the venting system should be performed before and after installation of this power vent. Consult local code officials and follow applicable installation codes.
- DO NOT INSTALL DAMAGED EQUIPMENT OR VENT COMPONENTS.**
- The exit termination of mechanical draft systems shall not be less than seven feet above grade when located adjacent to public walkways and at least ten feet from lot line or adjacent buildings.
- A mechanical drafting venting system shall terminate at least three feet above any forced air inlet located within ten feet.
- Disconnect electrical power supply before making wiring connections.
- Venting of more than one appliance in a common vent system is prohibited.

- Clearances between the vent pipe and combustible materials must be maintained at 3-inch top, 1-inch sides, and 1/2 inch bottom.
- All outer pipe joints must be sealed with high temperature silicone. See Section 7.A.

**CAUTION:** Failure to install, operate, and maintain the power venting system in accordance with manufacturer's instructions will result in conditions which may produce bodily injury and/or property damage.

**NOTICE:** The blower motors present in this appliance will generate sound during operation. The effects of the increased sound level can be minimized with careful planning during installation of the system. Locating the power vent service access grill in an area remote of immediate living space will reduce the effects of the added sound generated during operation.

#### 2. INSTALLATION GUIDELINES

**WARNING: RISK OF FIRE AND BURNS. DO NOT install PVI with the access panel facing upward. Overheating could occur.**

**NOTICE:** Installation of the PVI-DVP in an attic is not recommended in regions where temperatures reach 0°F (-18°C) and relative humidity exceeds 60% simultaneously. Low temperatures and high moisture content may cause the PVI-DVP to freeze.

- If the PVI-DVP is being installed in a confined space (such as a utility closet, mechanical room or attic space) with a total volume less than 720 cubic ft, an 8 inch by 16 inch hole will be required directly in front of the access panel. The confined space where PVI is installed, and the space to which the access hole opens, must add up to at least 720 cubic feet. This hole may be covered with a decorative cover as long as the cover has a minimum of 50% open air. This also applies to a fireplace chase.

If the PVI-DVP is being installed in a space greater than 720 cubic ft the 8 inch by 16 inch access hole is still required, but a solid cover may be used.

The decorative cover **CANNOT** be located on an outside wall that is open to the environment.

- For installations near loose-fill insulation (such as attics) a minimum clearance of six inches must be maintained between the access panel and the insulation.
- The access panel opening must be located such that access for service and adjustment is available. The NEC requires a minimum of 30 inches of space around the opening and 36 inches in front of the opening to the access panel. Consult officials having jurisdiction regarding regional requirements.

## Installation of Vent Pipe

For information on standard procedures for venting the appliance, refer to Section 7.

For the allowable pipe lengths and elbow combinations for this appliance, consult Section 4. The PVI uses DVP pipe (8 inch) connections for both the inlet and outlet.

See Section 12 to view the approved termination caps.

All outer pipe joints must be sealed with silicone with a minimum of 300°F continuous exposure rating, including the slip section that connects directly to the horizontal termination cap.

- Apply a bead of silicone sealant inside the female outer pipe joint prior to joining sections. See Figure 7.1.
- Only outer pipes need to be sealed. All unit collar, pipe, slip section, elbow and cap outer flues shall be sealed in this manner, unless otherwise stated.

## Vent Pipe Regulations

- A minimum of one 90 degree elbow and two feet straight vertical or eight feet vertical venting is required between the appliance and the PVI. Once this requirement is met, the PVI may be placed at any point in the venting configuration.
- A minimum of 18 inches is required between the PVI and the termination cap to allow room for the pipe to go through a wall or roof.

## Framing and Clearances

**Note:** The mounting brackets attached to the frame must be used to install the PVI-DVP.

### Chassis Dimensions

PVI-DVP Vertically Positioned as shown in Figure 4.6 and Figure 4.7.

Height	Width	Depth
18-7/8 in.	11-5/8 in.	13 in.

Table 1.

### Framing Dimensions

**WARNING! Risk of fire and burns! DO NOT install PVI with the access panel facing upward. Overheating could occur.**

Table 2 and Figure 4.6 show the clearances required for the PVI. Required clearances are the same for all allowable PVI orientations.

Height	Width	Depth
20-7/8 in.	13-5/8 in.	13-1/2 in.

Table 2.

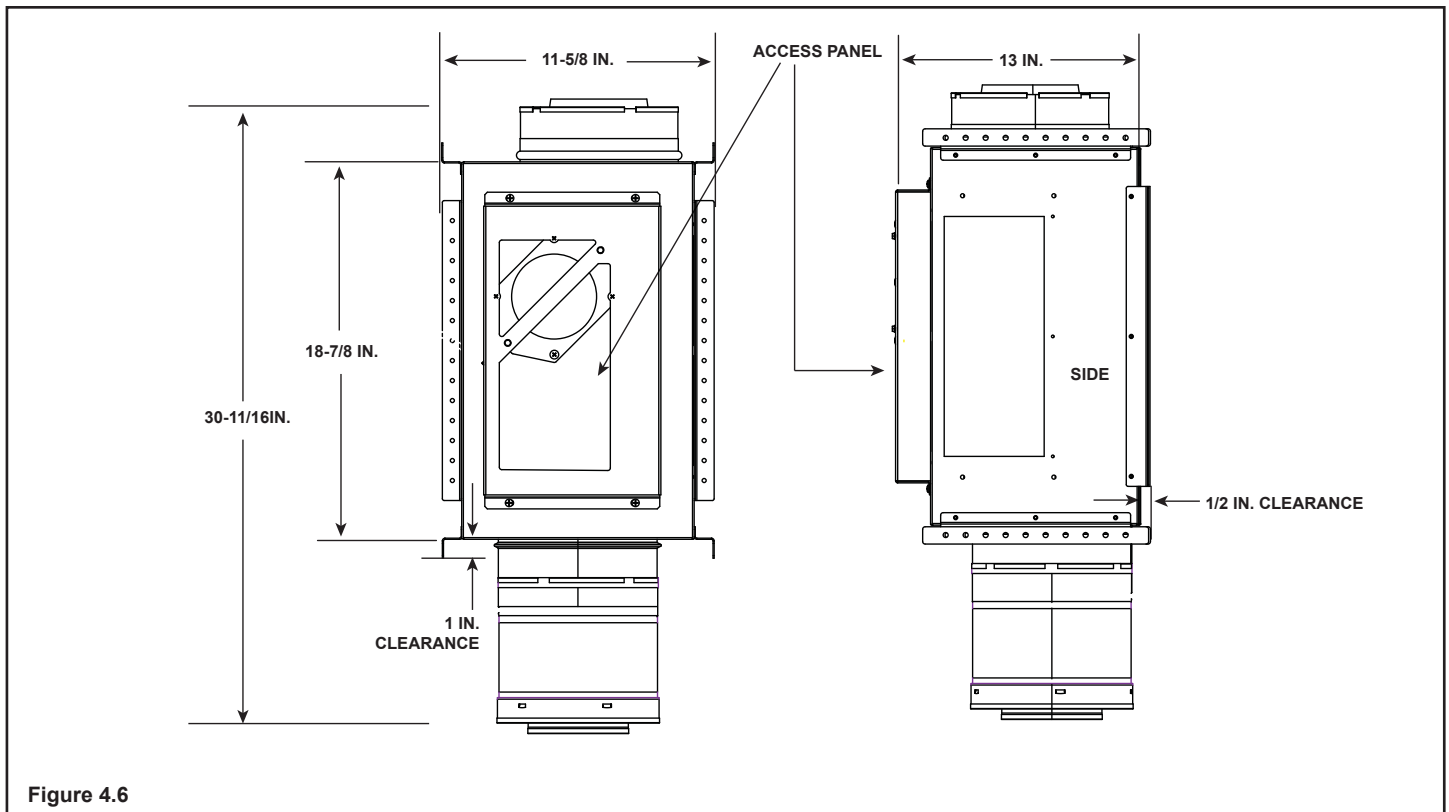
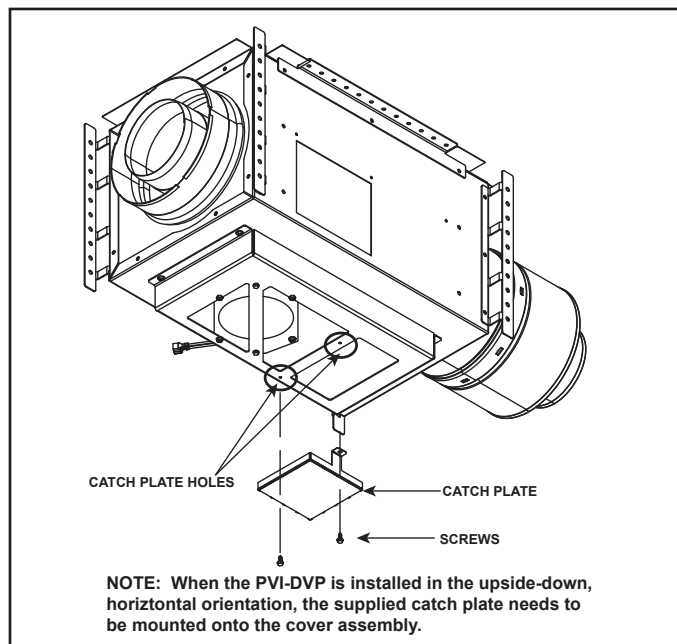
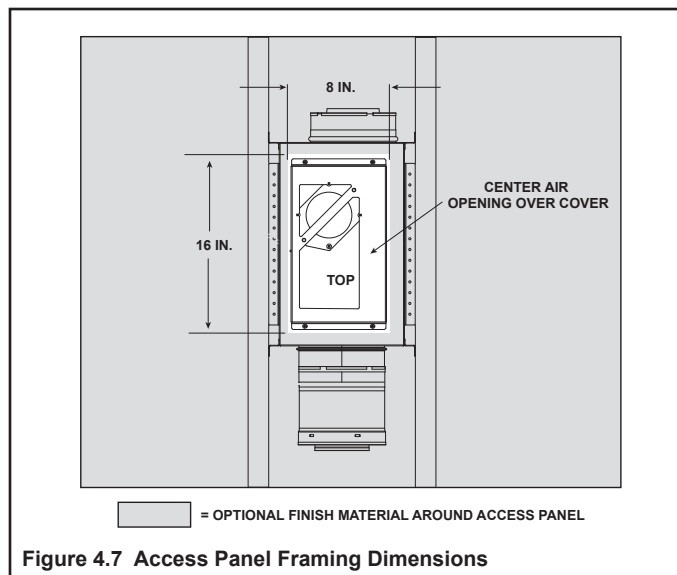

Figure 4.6

If the PVI-DVP is being installed in a confined space (such as a utility closet, mechanical room or attic space) with a total volume less than 720 cubic ft, an 8 inch by 16 inch hole will be required directly in front of the access panel. The confined space where PVI is installed, and the space to which the access hole opens, must add up to at least 720 cubic feet. This hole may be covered with a decorative cover as long as the cover has a minimum of 50% open air. This also applies to a fireplace chase. If the PVI-DVP is being installed in a space greater than 720 cubic ft the 8 inch by 16 inch access hole is still required, but a solid cover may be used.

The access panel opening must be located such that access for service and adjustment is available. The NEC requires a minimum of 30 inches of space around the opening and 36 inches in front of the opening to the access panel. Consult officials having jurisdiction regarding regional requirements.



Figures 4.9, 4.10, 4.11 and 4.12 show possible framing techniques.

**WARNING! Risk of fire and burns! DO NOT install PVI-DVP with the access panel facing upward. Overheating could occur.**

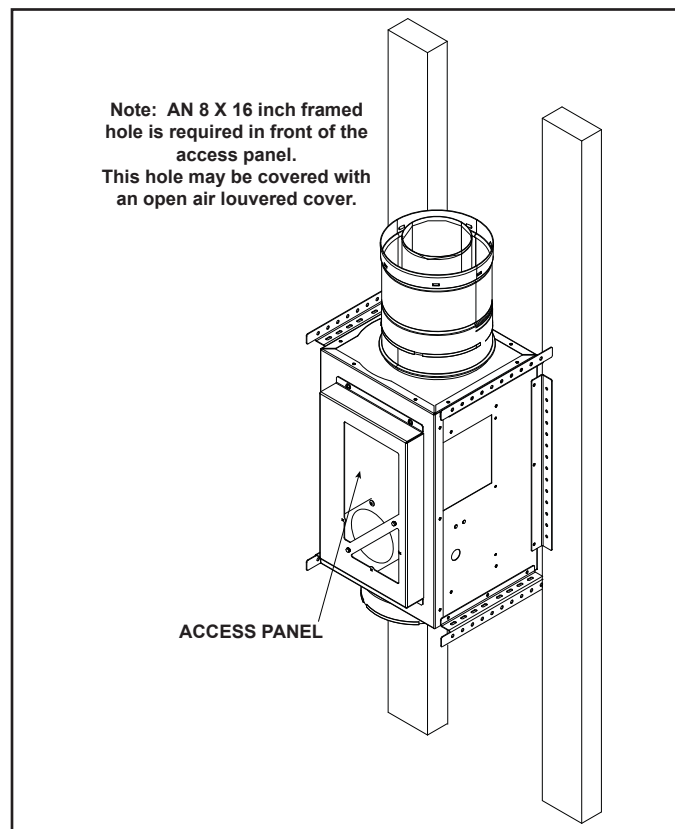
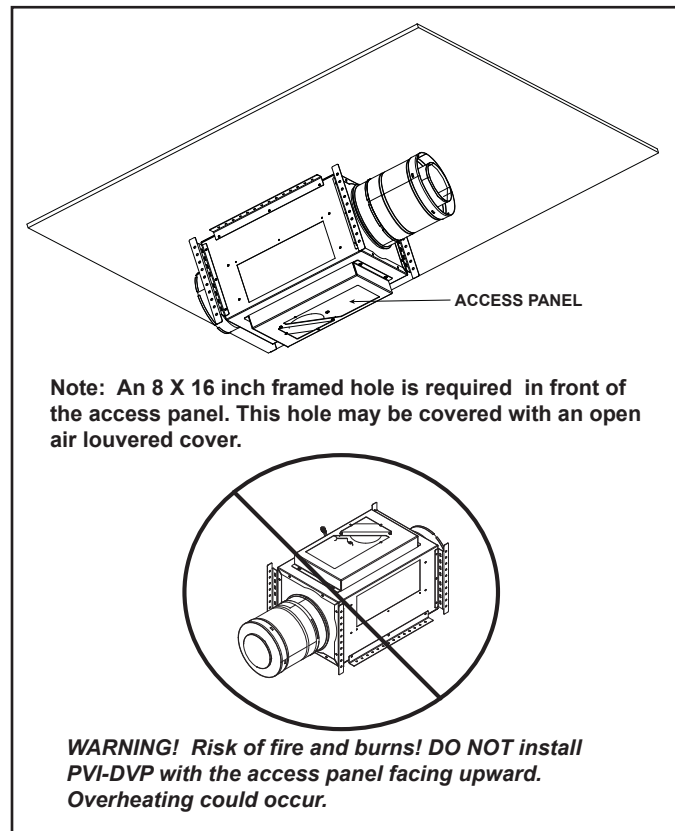

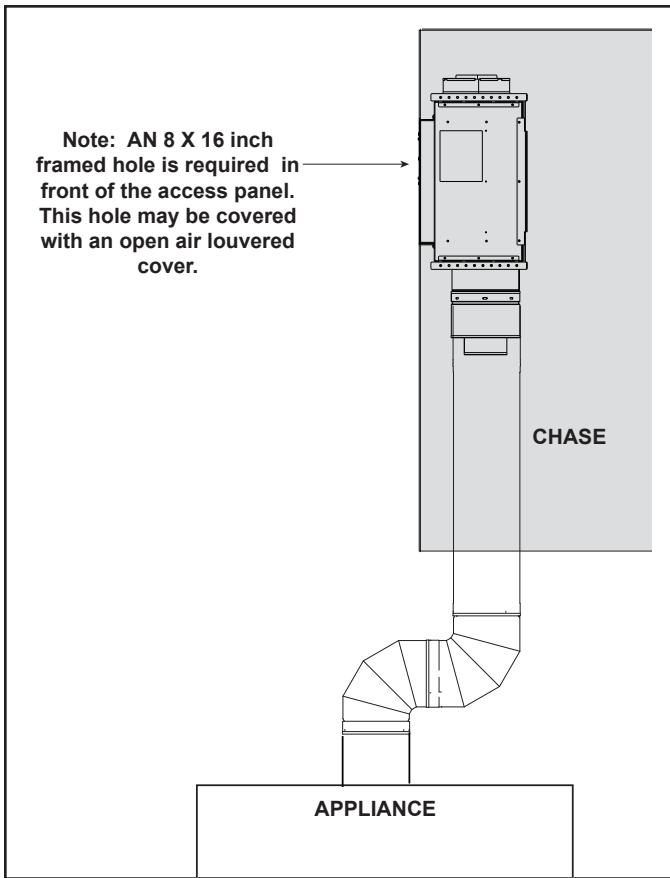

Figure 4.11 Mount PVI-DVP to Chase

Figure 4.12 and Figure 4.13 show the proper installation of the PVI-DVP if a louvered register is being used to provide free air.

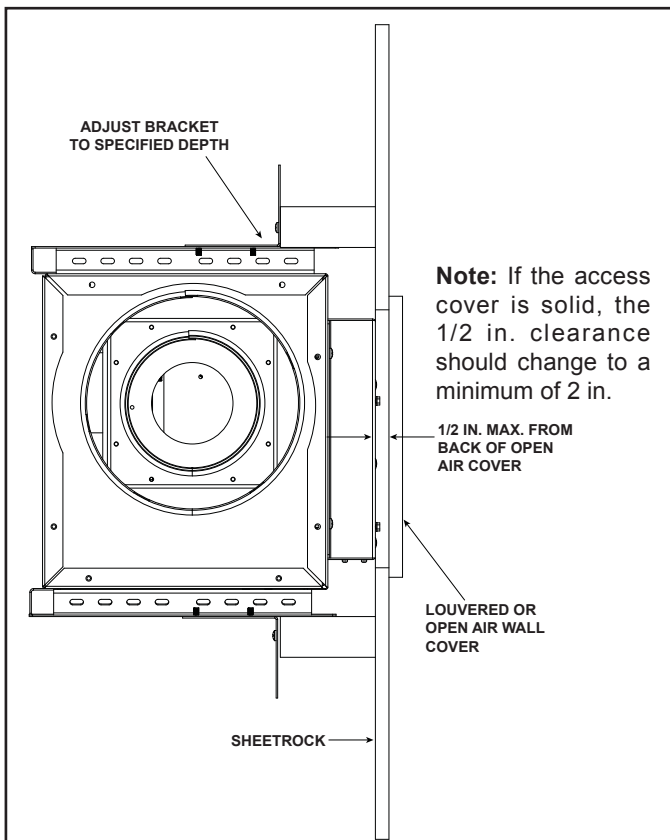

Figure 4.12 PVI-DVP Mounted with Fresh Air Access

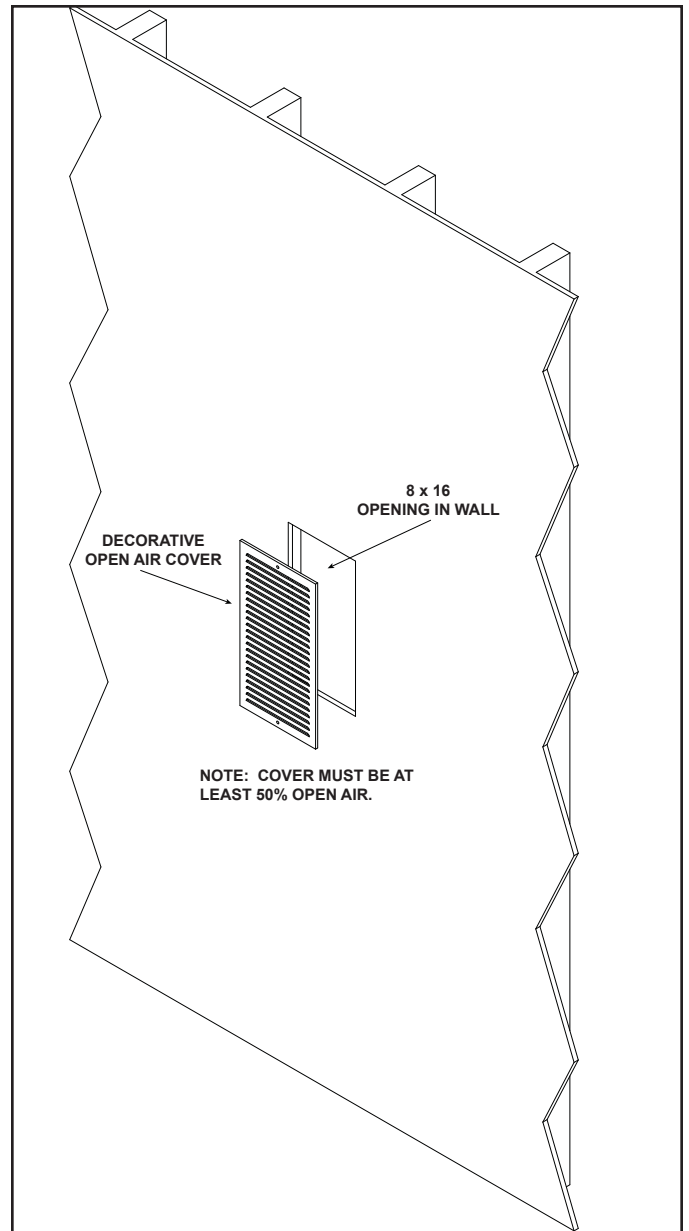

Figure 4.13

For additional scenarios to attach the PVI, the optional mounting brackets can be used. They can be secured to the side brackets on the PVI using wing nuts (supplied). The brackets can be attached anywhere along these designated holes. See Figure 4.14 and 4.15.



Figure 4.14





Figure 4.15

The optional mounting brackets may be used when mounting the PVI to a studded wall. See Figure 4.15.

Securing the PVI inside a floor joist can be easily done using the side brackets. See figure 4.16. If the side brackets can't be used, or additional support is needed, the optional mounting brackets can be used as shown in Figure 4.17 and Figure 4.18.



Figure 4.16

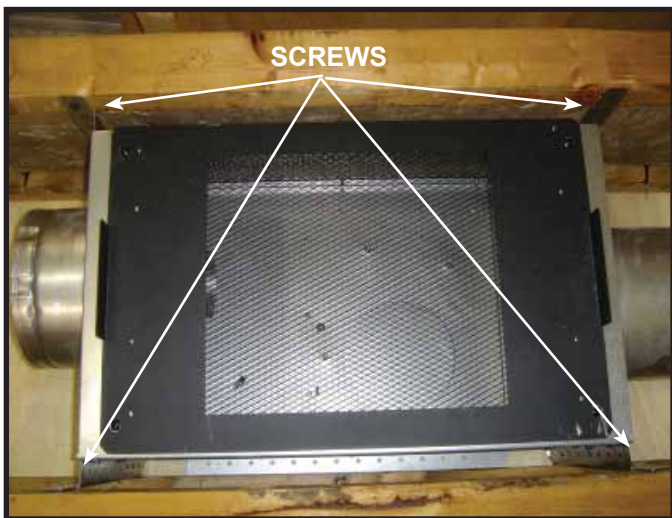

Figure 4.17



Figure 4.18

## Wiring the PVI-DVP

**NOTICE:** Electrical wiring must be done in accordance with national, provincial, and/or local electric codes.

**CAUTION: Risk of shock!** Disconnect electrical power from fireplace/power vent before performing any maintenance, repair, or electrical wiring.

**NOTICE:** Electrical service of 110-120 VAC must be supplied to the junction box of the fireplace in order for the power vent to operate correctly.

### 1. Wire Harness

- Determine the length of the wire harness required to run between the PVI-DVP and the appliance from the service parts list.
- On the end closest to the junction box, drill a 7/8 inch diameter hole and lead wire cable assembly through a Romex connector.
- Attach the end of the harness with the loose wires to the PVI-DVP. Use supplied zip ties to contain all loose wiring. See Figure 4.20 and Figure 4.21.
- Attach the end of the harness with the connector to the appliance.

### 2. PVI-DVP Connections

Refer to the PVI-DVP wiring diagram (Figure 8.6).

- Attach the green wire from the harness to the quick ground connect. Connect the red wire to one of the spades on the vacuum switch. Connect the brown wire to the remaining spade on the vacuum switch.
- Connect the white wire from the harness to the open female connector on harness, inside the PVI.
- Connect the black wire from the harness to the open male connector on harness, inside the PVI.

### 3. RED60 Connections

Refer to the RED60 wiring diagram, Figure 4.19. Ensure wire harness has been fastened to the appliance. Route wires and wire harness in a manner that protects them from contact with sharp metal surfaces.

- Attach the white, 3-wire connector to the AUX #2 connector on the AUX300.
- Connect the brown wire to the brown wire coming from the 8K1-PVI.
- Connect the red wire to the red wire coming from the 8K1-PVI.

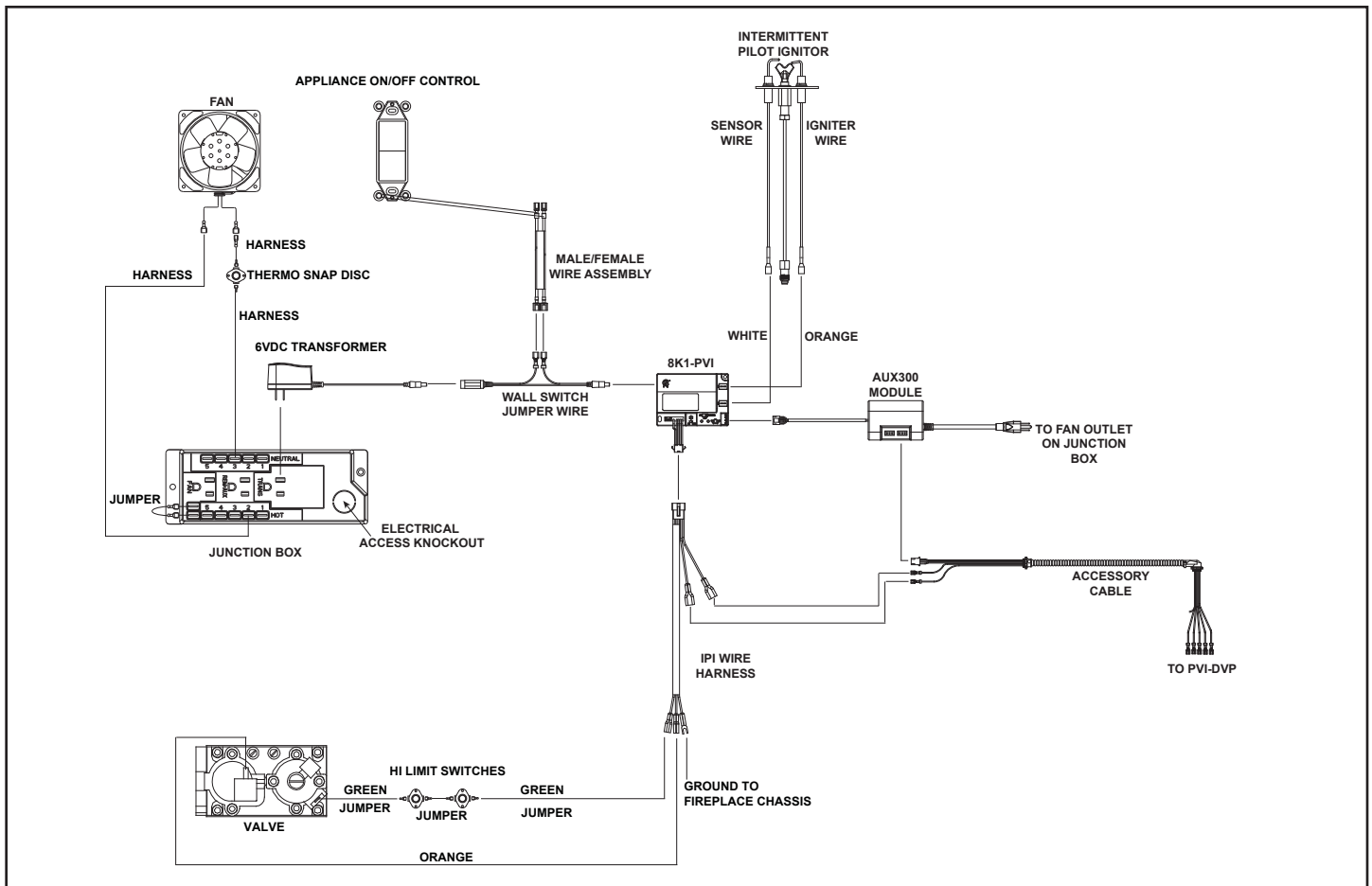

Figure 4.19 RED60 PVI-DVP with IntelliFire Plus Pilot Ignition Wiring Diagram

## Installation Inspection

1. Follow safety inspection procedures recommended by national, provincial, and/or local codes.
2. Be certain all electrical connections are properly made and secure.
3. Visually inspect the vent system and determine that there is no flue gas spillage, blockage or restriction, leakage, corrosion or other unsafe deficiencies.
4. Place the fireplace in operation and determine that the burner and power vent are operating properly. The main burner should show no signs of floating, lifting, or flashbacks.

**WARNING:** If any unsafe condition is determined when inspecting the installation and operation of the fireplace and Power Vent, the equipment should be shut off. Corrections **MUST** be made before the equipment is put into continuous operation.

## Vacuum Switch Orientation

**WARNING! Risk of Fire and Explosion!** Install vacuum switch on a vertical plane. Failure to follow instructions could result in fire or explosion.

If the PVI is mounted in a vertical position, the vacuum switch needs to be moved. To do this, loosen and remove the two nuts currently using to secure it to the inside wall of the PVI. Move and secure the vacuum switch onto the adjacent wall using the two bolts that are sticking out of the surface. See Figure 4.20 for the location on the vert-

cal plane in regards to horizontal or vertical orientation. The vacuum switch must be installed on a vertical plane. If the PVI is orientated horizontally in the vent run, install the vacuum switch in location "A" noted in Figure 4.20. If the PVI is orientated vertically in the vent run, install the vacuum switch in location "B" in Figure 4.20. Follow instructions on label attached inside the PVI. Remove the label as directed. See Figure 4.21 for the switch and wire orientation.

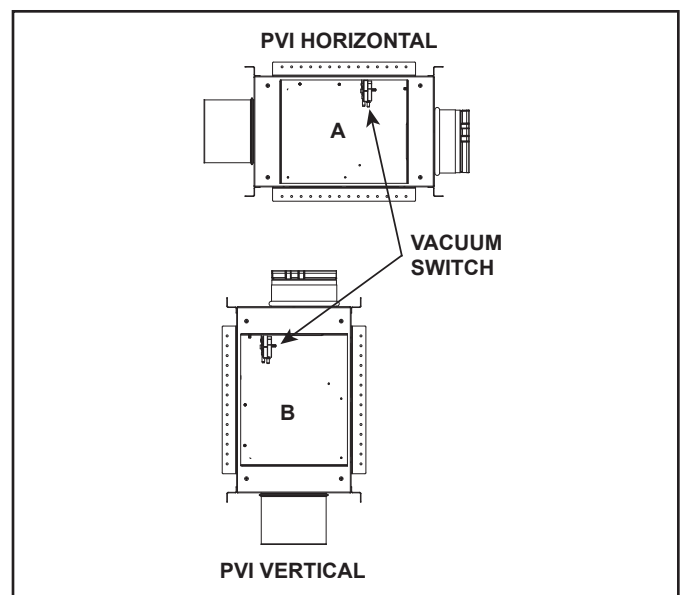

Figure 4.20 Vacuum Switch Location - Horizontal/Vertical Orientation



**CAUTION:** Risk of electrical shock! DO NOT allow 110-120 VAC wires to contact hot metal surfaces. Use supplied wire ties to bundle wires away from flue pipe, blower housing and other metal surfaces.

**CAUTION!** DO NOT allow wires to touch blower. Wire insulation will melt. Power vent will malfunction.

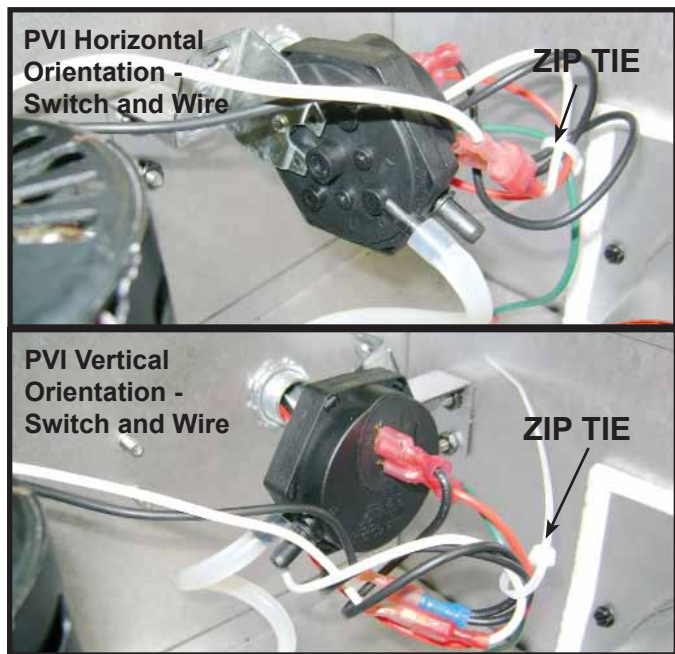

Figure 4.21 PVI Switch and Wire Orientation-Horizontal/Vertical

## Operating Instructions

After installation of the power vent, follow the operation instructions of the fireplace.

1. Turn the ON/OFF/REMOTE switch on the black IPI module to the ON position. When using a wall switch to control the operation of the appliance, the ON/OFF/REMOTE switch on the black IPI module must be in the ON position.
2. Turn the fireplace ON/OFF switch to "ON".

**Note:** During periods of operation after turning the fireplace "ON", there will be a delay of at least 120 seconds before the fireplace ignites. This is due to the time necessary for the fan to reach operating speed and to remove any gases from the combustion chamber.

3. After turning the switch to the "ON" position, if the fireplace does not turn on, shut the switch to "OFF" and inspect the power vent system for any debris that may be obstructing the fan blade movement.
4. Turn the fireplace ON/OFF switch to "OFF" to turn off the burner and the power vent.

## Maintenance

**CAUTION!** Before performing any maintenance or repair to the power vent assembly, make sure electrical power is disconnected to the fireplace.

1. Vent System: Inspect all components and connections annually. Replace, seal, or tighten pipe connections if necessary.
2. Power Vent Cap: Inspect at least annually, to clear away any debris blocking any part of the cap.
3. Motor: The blower motor bearings are sealed and no further lubrication is necessary. To access the motor, vacuum switch or pressure sense tube, refer to Figure 4.22.

If the motor needs to be removed, take out the three screws that attach the collar to the wall and the five nuts holding the motor down as shown in Figure 4.23.

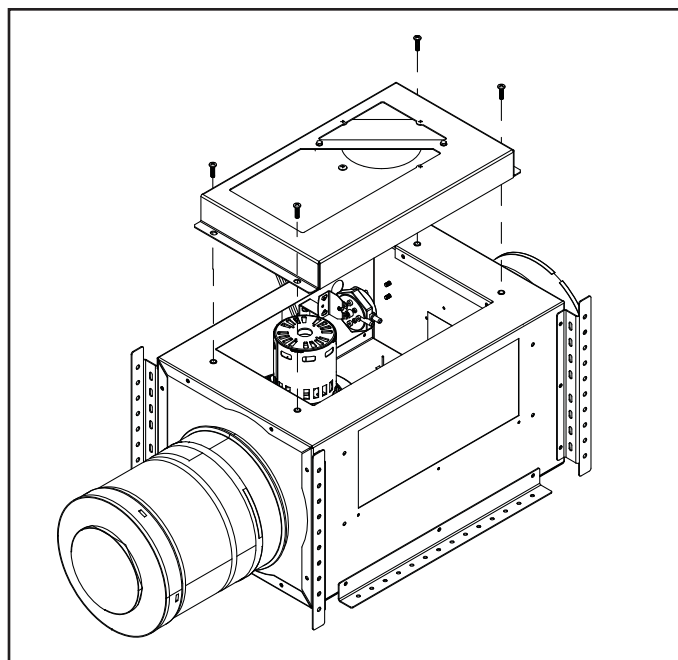

Figure 4.22 Motor and Electrical Access

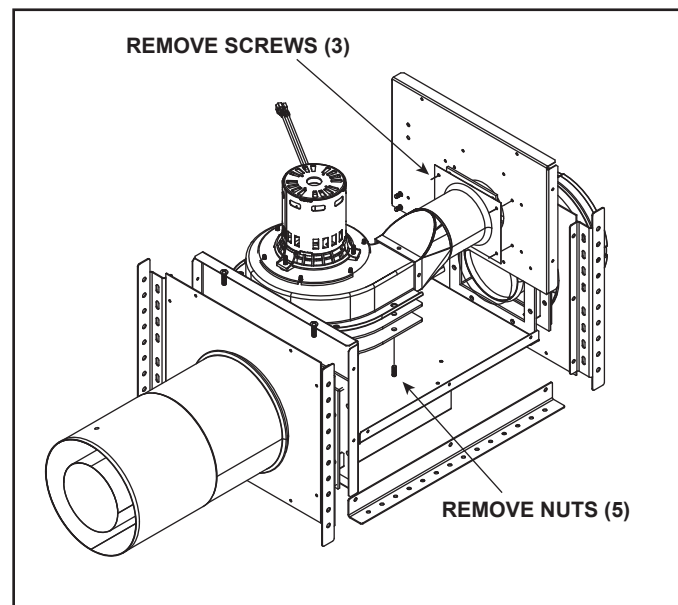

Figure 4.23 Motor Service

## H. Vent Diagrams

### ⚠ WARNING



Fire Risk. Explosion Risk.  
 Do NOT pack insulation or other combustibles between ceiling firestops.  
 • ALWAYS maintain specified clearances around venting and firestop systems.  
 • Install wall shield and ceiling firestops as specified.  
 Failure to keep insulation or other material away from vent pipe could cause fire.



### Top Vent - Horizontal Termination Venting with 1 elbow

V <sub>1</sub> Minimum		V <sub>1</sub> + H <sub>1</sub> Maximum	
2 ft.	610 mm	60 ft.	18.3 m
3 ft.	914 mm	70 ft.	21.3 m
4 ft.	1.2 m	80 ft.	24.4 m
V <sub>1</sub> + H <sub>1</sub> = 80 ft. (24.4 m) Maximum			

**Note:** Must have 24 inches minimum vertical vent prior to attaching any elbow to the appliance.

**Note:** Use DVP Series components only.

**Note:** PVI-DVP can be located in any position except V<sub>1</sub>.

**WARNING! Risk of fire and burns!**  
 DO NOT install PVI-DVP with the access panel facing upward. **Overheating could occur.**

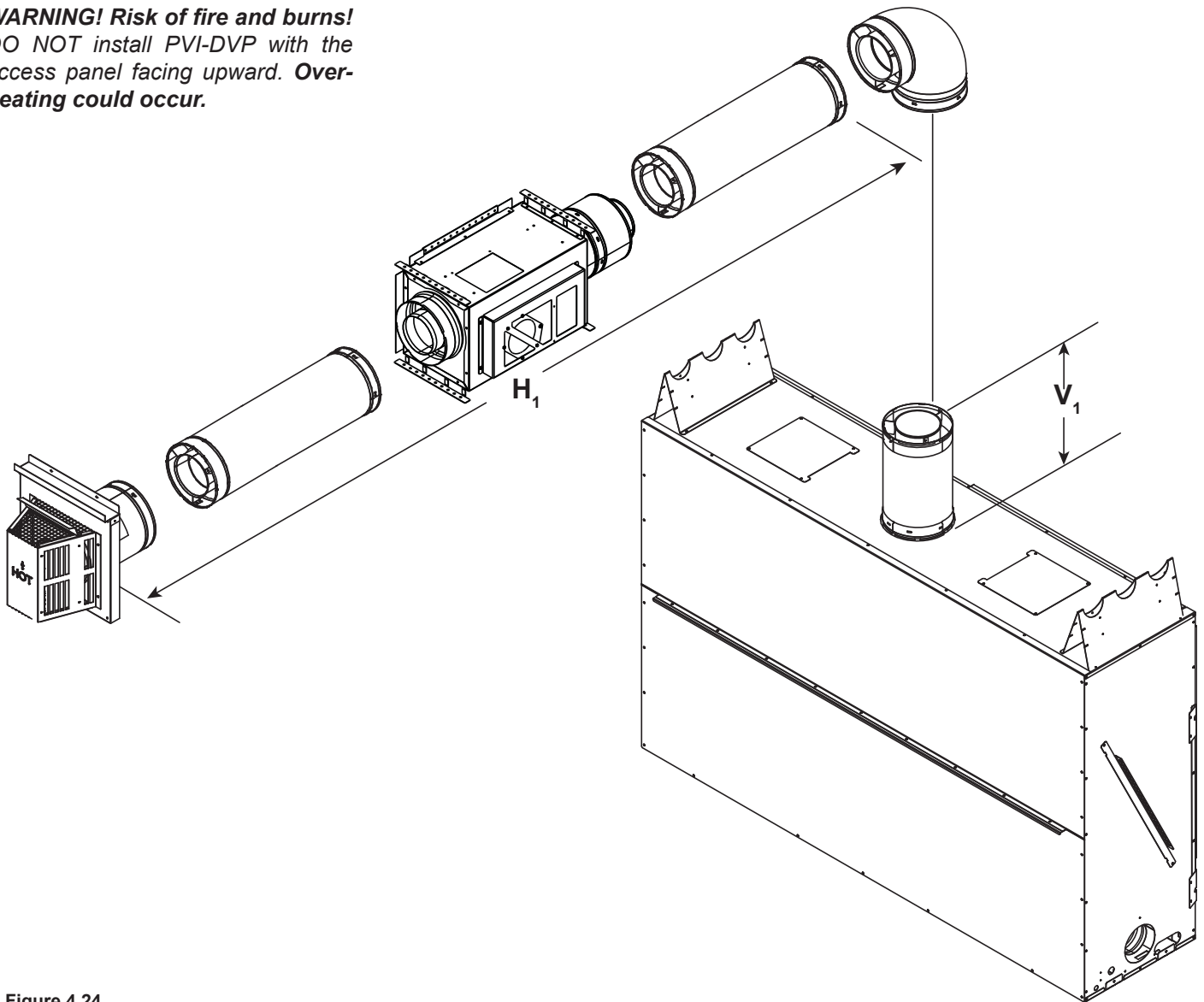

Figure 4.24

Top Vent - Horizontal Termination - (continued)

Top Vent - Horizontal Termination  
Venting with 2 elbows

V <sub>1</sub> Minimum		V <sub>1</sub> + H <sub>1</sub> + H <sub>2</sub> Maximum	
2 ft.	610 mm	50 ft.	15.2 m
3 ft.	914 mm	60 ft.	18.3 m
4 ft.	1.2 m	70 ft.	21.3 m
V <sub>1</sub> + H <sub>1</sub> + H <sub>2</sub> = 70 ft. (21.3 m) Maximum			

**Note:** Must have 24 inches minimum vertical vent prior to attaching any elbow to the appliance.

**Note:** Use DVP Series components only.

**Note:** PVI-DVP can be located in any position except V<sub>1</sub>.

**WARNING! Risk of fire and burns!**  
DO NOT install PVI-DVP with the access panel facing upward. Overheating could occur.

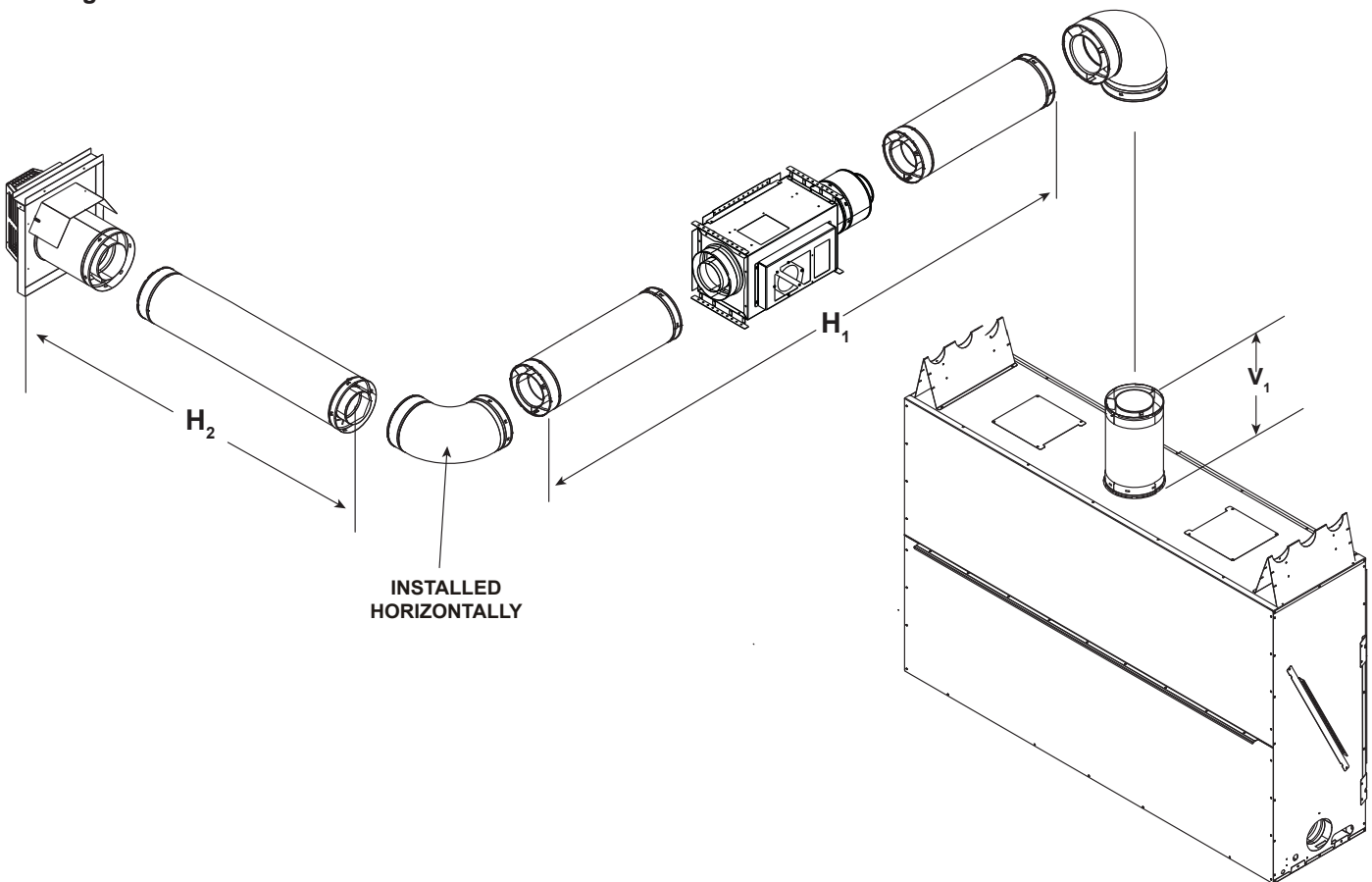

Figure 4.25

Top Vent - Horizontal Termination - (continued)

Top Vent - Horizontal Termination  
Venting with 3 elbows

V <sub>1</sub> Minimum		V <sub>1</sub> + V <sub>2</sub> + H <sub>1</sub> + H <sub>2</sub> Maximum	
2 ft.	610 mm	40 ft.	12.2 m
3 ft.	914 mm	50 ft.	15.2 m
4 ft.	1.2 m	70 ft.	21.3 m
V <sub>1</sub> + V <sub>2</sub> + H <sub>1</sub> + H <sub>2</sub> = 70 ft. (21.3 m) Maximum			

**Note:** Must have 24 inches minimum vertical vent prior to attaching any elbow to the appliance.

**Note:** Use DVP Series components only.

**Note:** PVI-DVP can be located in any position except V<sub>1</sub>.

**WARNING! Risk of fire and burns!**  
DO NOT install PVI-DVP with the access panel facing upward. Overheating could occur.

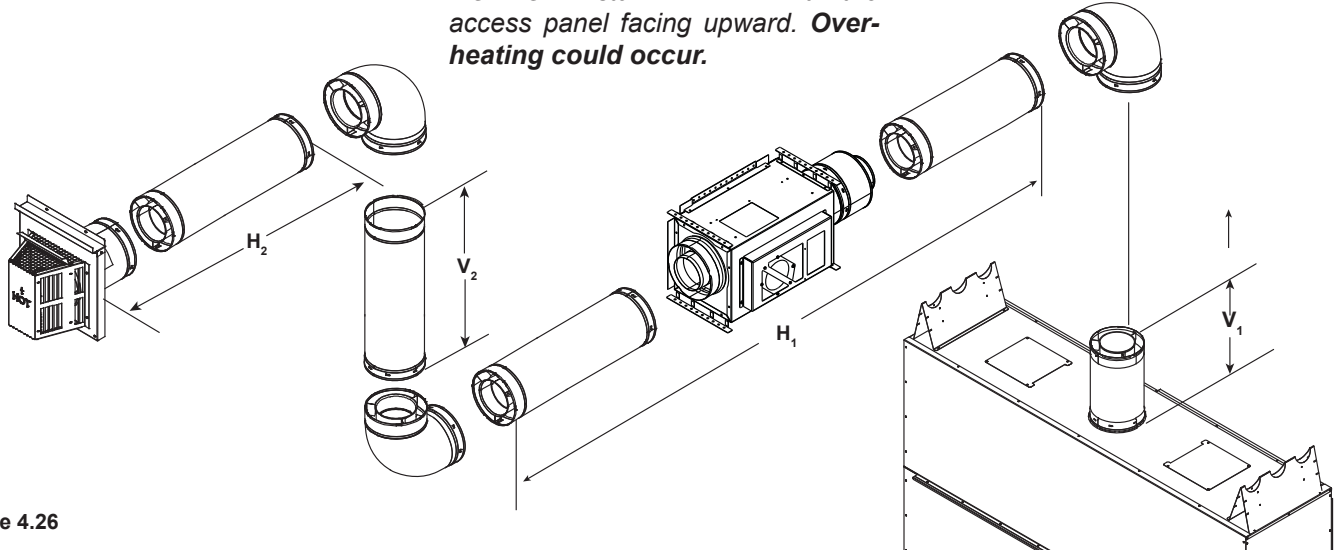

Figure 4.26

Top Vent - Horizontal Termination  
Venting with more than 3 elbows

**Note:** Must have 24 inches minimum vertical vent prior to attaching any elbow to the appliance.

**Note:** Use DVP Series components only.

**Note:** PVI-DVP can be located in any position except V<sub>1</sub>.

**WARNING! Risk of fire and burns!**  
DO NOT install PVI-DVP with the access panel facing upward. Overheating could occur.

4 Elbows			
V <sub>1</sub> Minimum		Total V + Total H Maximum	
2 ft.	610 mm	30 ft.	9.1 m
3 ft.	914 mm	40 ft.	12.2 m
4 ft.	1.2 m	60 ft.	18.3 m
TOTAL V + TOTAL H = 60 ft. (18.3 m) Maximum			

5 Elbows			
V <sub>1</sub> Minimum		Total V + Total H Maximum	
2 ft.	610 mm	30 ft.	9.1 m
3 ft.	914 mm	40 ft.	12.2 m
4 ft.	1.2 m	50 ft.	15.2 m
Total V + Total H = 50 ft. (15.2 m) Maximum			

6 Elbows			
V <sub>1</sub> Minimum		Total V + Total H Maximum	
2 ft.	610 mm	10 ft.	3.0 m
3 ft.	914 mm	20 ft.	6.0 m
4 ft.	1.2 m	40 ft.	12.2 m
Total V + Total H = 40 ft. (12.2 m) Maximum			

## Top Vent - Vertical Termination No Elbows

$V_1 = 8 \text{ ft. Min. (2.4 m)}$

$V_2 = 50 \text{ ft. Max. (15.2 m)}$

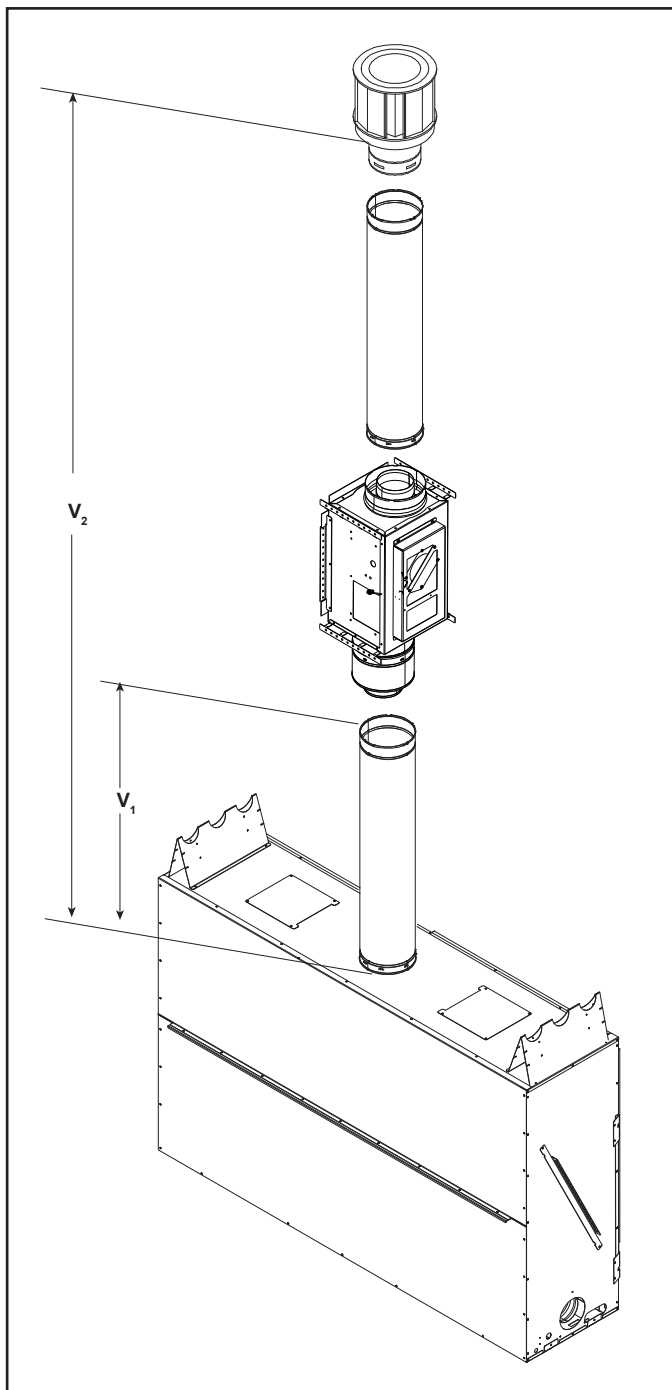

Figure 4.27 Vertical Vent Maximum

## Top Vent - Vertical Termination Venting with 2 elbows

**Note:** Must have 24 inches minimum vertical vent prior to attaching any elbow to the appliance.

**Note:** Use DVP Series components only.

**Note:** PVI-DVP can be located in any position except  $V_1$ .

$V_1$ Minimum		$V_1 + V_2 + H$ Maximum	
2 ft.	610 mm	50 ft.	15.2 m
3 ft.	914 mm	60 ft.	18.3 m
4 ft.	1219 mm	70 ft.	21.3 m
$V_1 + V_2 + H_1 = 70$ ft. (21.3 m) Maximum			

**WARNING! Risk of fire and burns!**  
DO NOT install PVI-DVP with the access panel facing upward. Overheating could occur.

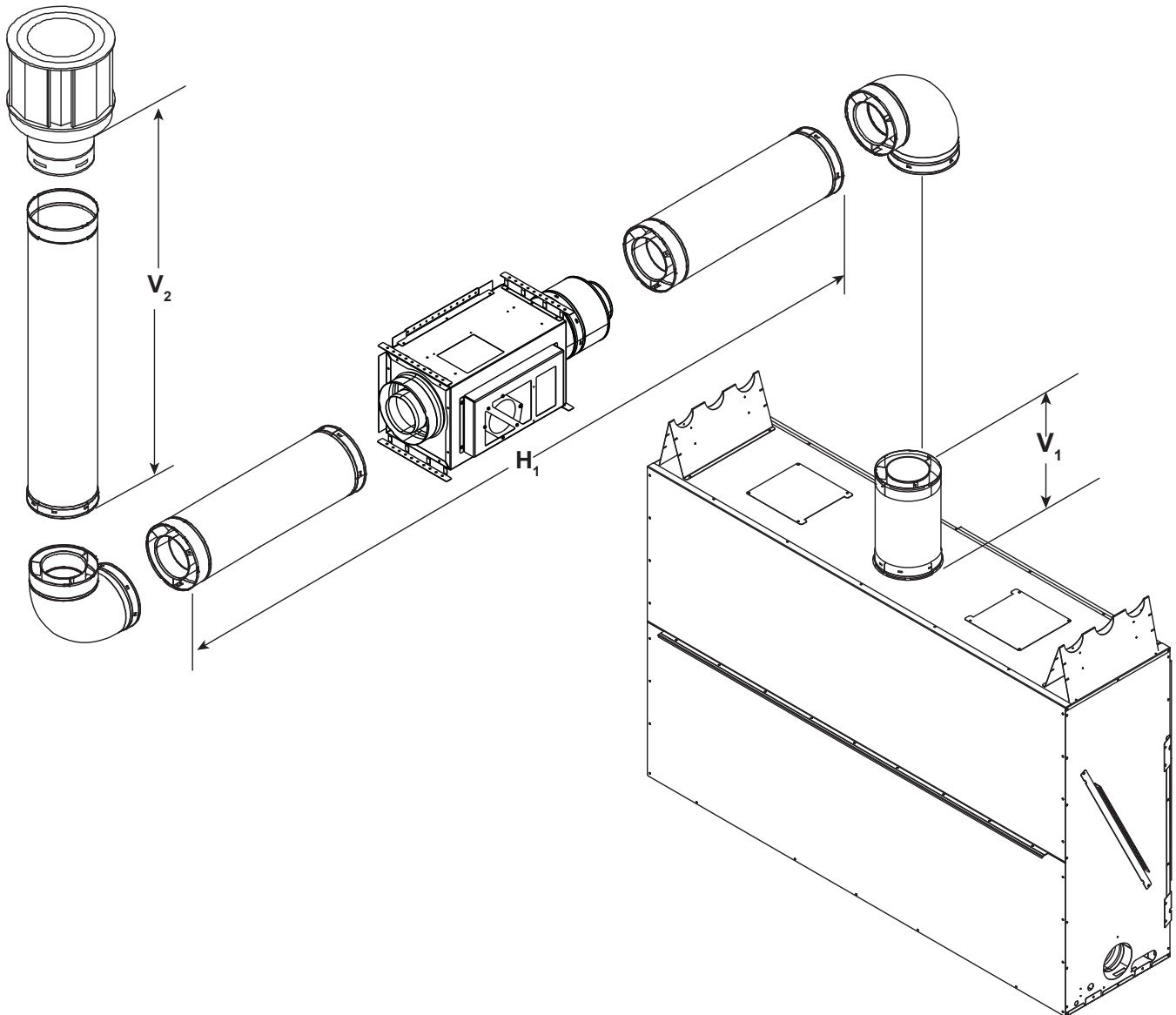

Figure 4.28



## Top Vent - Vertical Termination Venting with 3 elbows

**Note:** Must have 24 inches minimum vertical vent prior to attaching any elbow to the appliance.

**Note:** PVI-DVP can be located in any position except  $V_1$ .

**Note:** Use DVP Series components only.

$V_1$ Minimum		$V_1 + V_2 + H_1 + H_2$ Maximum	
2 ft.	610 mm	40 ft.	12.2 m
3 ft.	914 mm	50 ft.	15.2 m
4 ft.	1219 mm	70 ft.	21.3 m
$V_1 + V_2 + H_1 + H_2 = 70$ ft. (21.3 m) Maximum			

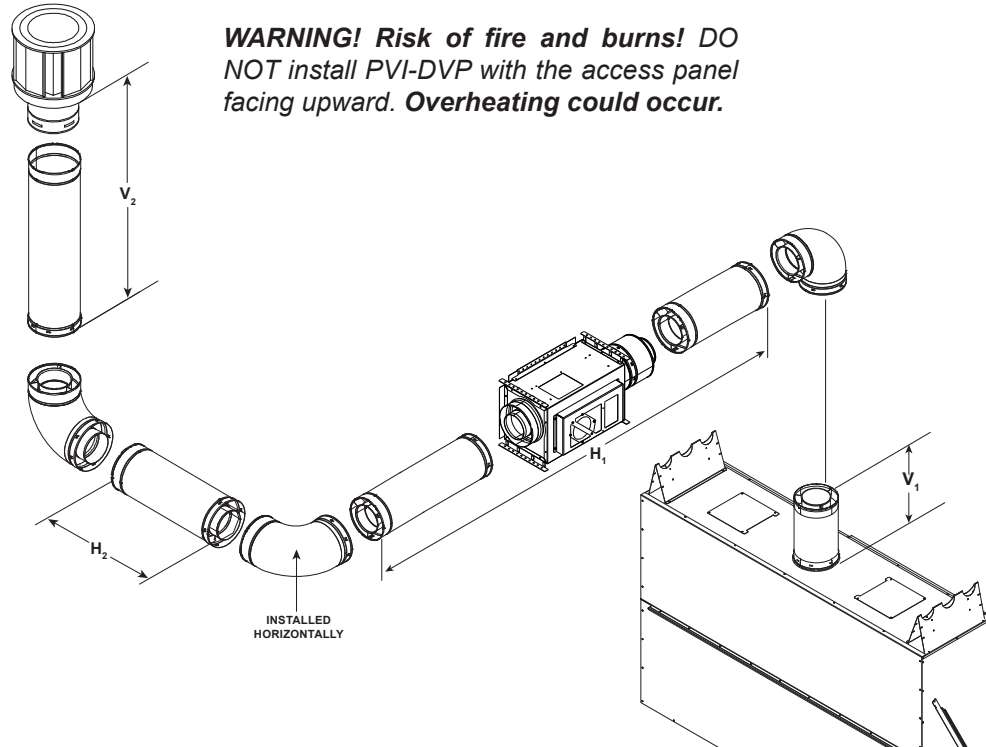

Figure 4.29

## Top Vent - Vertical Termination Venting with more than 3 elbows

**Note:** Must have 24 inches minimum vertical vent prior to attaching any elbow to the appliance.

**Note:** PVI-DVP can be located in any position except  $V_1$ .

**Note:** Use DVP Series components only.

**WARNING! Risk of fire and burns! DO NOT install PVI-DVP with the access panel facing upward. Overheating could occur.**

5 Elbows			
$V_1$ Minimum		Total V + Total H Maximum	
2 ft.	610 mm	30 ft.	9.1 m
3 ft.	914 mm	40 ft.	12.2 m
4 ft.	1.2 m	50 ft.	15.2 m
Total V + Total H = 50 ft. (15.2 m) Maximum			

4 Elbows			
$V_1$ Minimum		Total V + Total H Maximum	
2 ft.	610 mm	30 ft.	9.1 m
3 ft.	914 mm	40 ft.	12.2 m
4 ft.	1.2 m	60 ft.	18.3 m
TOTAL V + TOTAL H = 60 ft. (18.3 m) Maximum			

6 Elbows			
$V_1$ Minimum		Total V + Total H Maximum	
2 ft.	610 mm	10 ft.	3.0 m
3 ft.	914 mm	20 ft.	6.0 m
4 ft.	1.2 m	40 ft.	12.2 m
Total V + Total H = 40 ft. (12.2 m) Maximum			

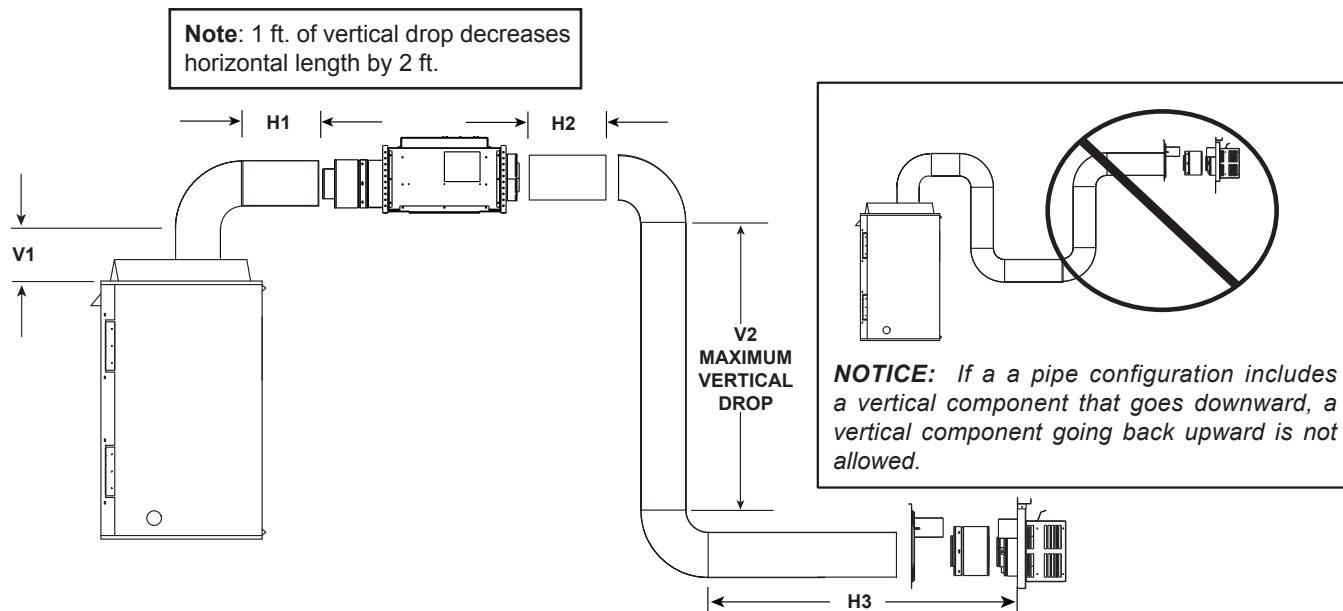

**NOTE:** Maximum total vent run = Total vertical vent run + Total horizontal vent run

DIRECT VENT WITH 2 FT. MINIMUM VERTICAL OFF TOP OF APPLIANCE		
MAX. ELBOWS (45° & 90°)	MAX. TOTAL VENT RUN Total V + Total H (FT.)	MAX. VERT. DROP V <sub>2</sub> (FT.)
3	26 ft.	7 ft.
4	16 ft.	7 ft.
5	16 ft.	7 ft.
*1 ft. vertical drop decreases horizontal length by 2 ft.		

DIRECT VENT WITH 3 FT. MINIMUM VERTICAL OFF TOP OF APPLIANCE		
MAX. ELBOWS (45° & 90°)	MAX. TOTAL VENT RUN Total V + Total H (FT.)	MAX. VERT. DROP V <sub>2</sub> (FT.)
3	30 ft.	7 ft.
4	22 ft.	7 ft.
5	22 ft.	7 ft.
*1 ft. vertical drop decreases horizontal length by 2 ft.		

DIRECT VENT WITH 4 FT. MINIMUM VERTICAL OFF TOP OF APPLIANCE		
MAX. ELBOWS (45° & 90°)	MAX. TOTAL VENT RUN Total V + Total H (FT.)	MAX. VERT. DROP V <sub>2</sub> (FT.)
3	45 ft.	7 ft.
4	38 ft.	7 ft.
5	30 ft.	7 ft.
6	22 ft.	7 ft.
*1 ft. vertical drop decreases horizontal length by 2 ft.		

**EXAMPLE:** An appliance with 3 ft. vertical off the top (V<sub>1</sub>), a vertical drop of 6 ft. (V<sub>2</sub>) and a total of 4 elbows can have a maximum vent run length (Total V + Total H) of 10 ft.

$$22 \text{ ft.} - (6 \text{ ft. vertical drop} \times 2^*) = 10 \text{ ft.}$$

Figure 4.30 Power Vent Positioned Before Vertical Drop

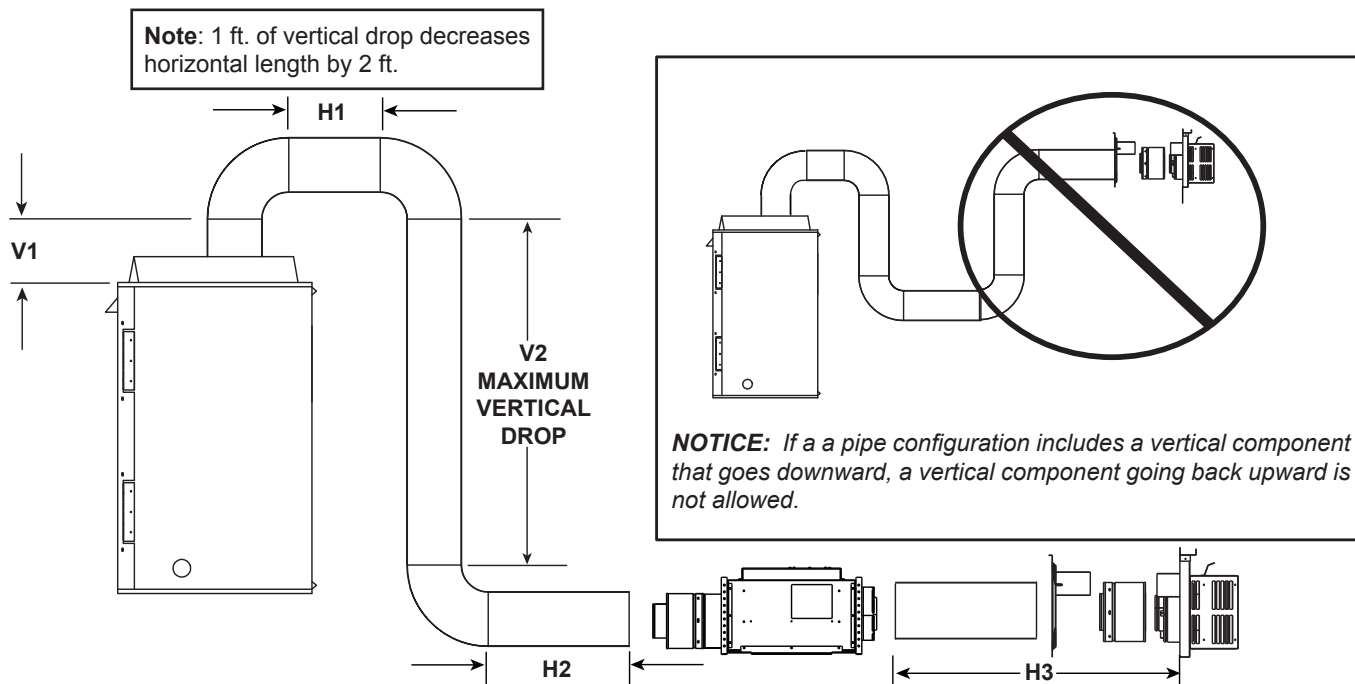

**NOTE:** Maximum total vent run= Total vertical vent run + Total horizontal vent run

DIRECT VENT WITH 2 FT. MINIMUM VERTICAL OFF TOP OF APPLIANCE		
MAX. ELBOWS (45° & 90°)	MAX. TOTAL VENT RUN Total V + Total H (FT.)	MAX. VERT. DROP V <sub>2</sub> (FT.)
3	34 ft.	7 ft.
4	22 ft.	7 ft.
5	22 ft.	7 ft.
*1 ft. vertical drop decreases horizontal length by 2 ft.		

DIRECT VENT WITH 3 FT. MINIMUM VERTICAL OFF TOP OF APPLIANCE		
MAX. ELBOWS (45° & 90°)	MAX. TOTAL VENT RUN Total V + Total H (FT.)	MAX. VERT. DROP V <sub>2</sub> (FT.)
3	40 ft.	7 ft.
4	30 ft.	7 ft.
5	30 ft.	7 ft.
*1 ft. vertical drop decreases horizontal length by 2 ft.		

DIRECT VENT WITH 4 FT. MINIMUM VERTICAL OFF TOP OF APPLIANCE		
MAX. ELBOWS (45° & 90°)	MAX. TOTAL VENT RUN Total V + Total H (FT.)	MAX. VERT. DROP V <sub>2</sub> (FT.)
3	56 ft.	7 ft.
4	50 ft.	7 ft.
5	40 ft.	7 ft.
6	30 ft.	7 ft.
*1 ft. vertical drop decreases horizontal length by 2 ft.		

**EXAMPLE:** An appliance with 2 ft. vertical off the top (V<sub>1</sub>), a vertical drop of 5 ft. (V<sub>2</sub>) and a total of 3 elbows can have a maximum vent run length (Total V + Total H) of 24 ft.

$$34 \text{ ft.} - (5 \text{ ft vertical drop} \times 2^*) = 24 \text{ ft.}$$

Figure 4.31 Power Vent Positioned After Vertical Drop

## I. Installation Instructions and Venting Information - PVK-80 for RED60 Model

These instructions are for appliances utilizing the PVK-80 for the RED60 model. For appliances incorporating the PVI-DVP. See Section 4.G.

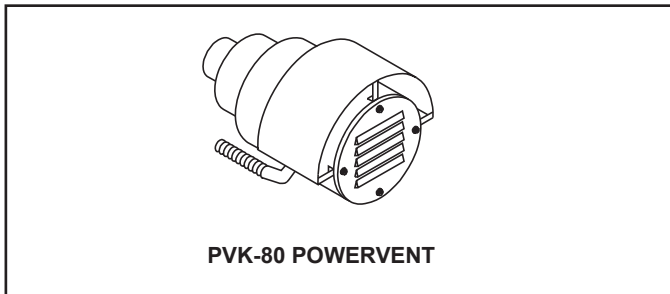

Figure 4.32 PVK-80 Power Vent

**IMPORTANT NOTE:** When installing the PVK-80 with the RED60 model, these PVK-80 installation instructions supersede the instructions that are included with the PVK-80 Power Vent Kit.

**WARNING! Risk of Fire!** Failure to follow these instructions could create a fire hazard and may void the fireplace warranty. Install PVK-80 on RED60 model per these instructions.

**THESE INSTRUCTIONS MUST REMAIN WITH THE EQUIPMENT.**

### INTRODUCTION

The PVK-80 Power Vent can be used on RED60 direct vent gas fireplaces manufactured by Hearth & Home Technologies.

The PVK-80 Power Vent operates on 110-120 VAC electrical service.

### Components and Service Parts List

#### Service Parts List

Replacement parts can be obtained from your dealer. Repair of the Power Vent should only be done by a qualified service technician. A list of replacement parts is shown in the instruction included with the PVK-80 kit.

### INSTALLATION PRECAUTIONS

1. This device must be installed by a qualified installer in accordance with these instructions.
2. Safety inspection of the venting system should be performed before and after installation of this power vent. Consult local code officials and follow applicable installation codes.
3. **DO NOT INSTALL DAMAGED EQUIPMENT OR VENT COMPONENTS.**
4. Disconnect electrical power supply before making wiring connections.
5. **VENTING OF MORE THAN ONE APPLIANCE IN A COMMON VENT SYSTEM IS PROHIBITED.**

6. **CLEARANCES BETWEEN THE VENT PIPE AND COMBUSTIBLE MATERIALS MUST BE MAINTAINED AT 3-INCH TOP, 1-INCH SIDES, AND 1-INCH BOTTOM.** See Figure 4.33.

7. **CAUTION:** Failure to install, operate, and maintain the power venting system in accordance with manufacturer's instructions will result in conditions which could produce bodily injury and/or property damage.

**NOTICE:** The blower motor present in this appliance will generate sound during operation. The effects of the increased sound level can be minimized with careful planning during installation of the system.

### INSTALLATION OF PVK-80 POWER VENT

1. Location of venting system terminations must be made in accordance with national, provincial, and/or local codes. The minimum clearance requirements must be followed on models using the PVK-80 Power Vent.
  - A. The exit termination of mechanical draft systems shall not be less than 7 feet above grade when located adjacent to public walkways and at least 10 feet from lot line or adjacent buildings.
  - B. A mechanical drafting venting system shall terminate at least 3 feet above any forced air inlet located within 10 feet.
  - C. The venting system of direct vent appliances shall terminate at least 12 inches below, 12 inches horizontally from, or 12 inches above any building opening through which flue gases could enter.
  - D. The vent termination point shall not be installed closer than 2 feet from an inside corner of an L-shaped structure.
  - E. The vent termination should not be mounted directly above or within 3 feet horizontally from an oil tank vent or gas meter.
  - F. The bottom of the vent termination shall be located at least 2 feet above the finished graded and 2 feet above any combustible projection.

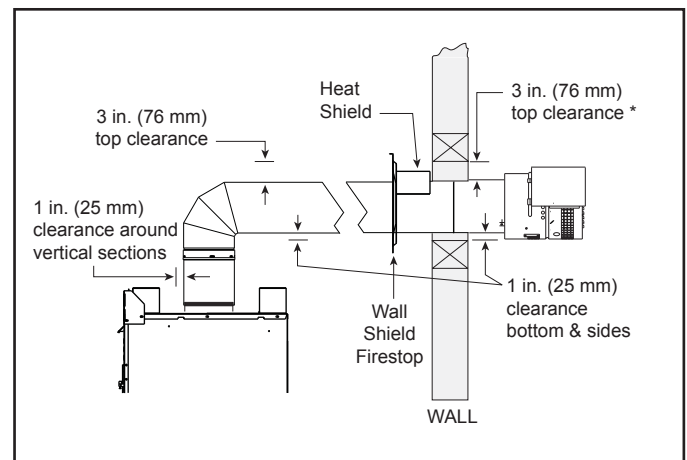

Figure 4.33

**NOTE:** The PVK-80 Power Vent must terminate in a **HORIZONTAL** position. See Figure 4.33.

2. Install vent system components per planned vent run. Route the vent pipe from the fireplace to the Power Vent using the minimum number of elbows possible.
3. After determining the location of the vent system termination point (see Step 1) cut a 10 in. X 12 in. rectangular hole through the wall or roof. Apply the adhesive back fiberglass tape to the last vent system component 1 1/4" from the edge. Firmly press the tape on to the venting and fold the extra tape inside the venting. See Figure 4.34. Mount and attach the power vent to the last vent system component. The exhaust port of the PVK-80 cap **MUST** be pointed down. Fasten the last horizontal vent section to the exterior firestop with a sheet metal screw through the flange and into the vent pipe. See Figure 4.35.

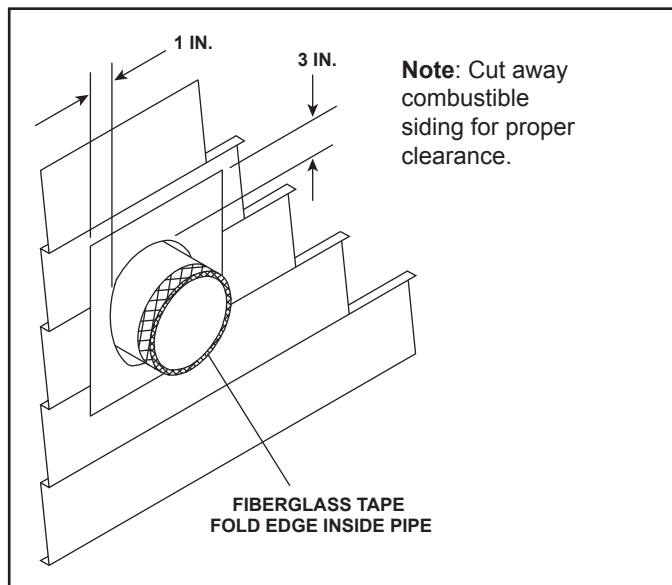

Figure 4.34

**NOTE:** Wall firestops (not included with the Power Vent) are available for DVP vent pipe. The firestop **MUST** be used whenever a section of vent pipe passes through a combustible wall.

5. The minimum distance from the outside wall to the end of the top shield of the PVK-80 horizontal cap is 14-1/2 inches. The maximum distance is 21 inches. See Figure 4.36.
6. Two support braces are provided and **MUST** be used to mount the PVK-80 horizontal cap to the wall. Screw one end of each brace to the bottom of the cap housing, using the pilot holes in the cap. Extend each brace until it contacts the building wall and tighten the bolt/nut in the center of each brace. Fasten the other end of each brace to the outside wall. See Figure 4.36.

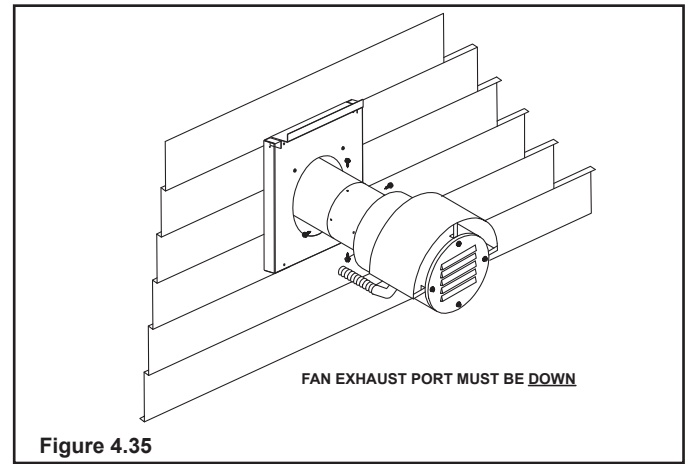

Figure 4.35

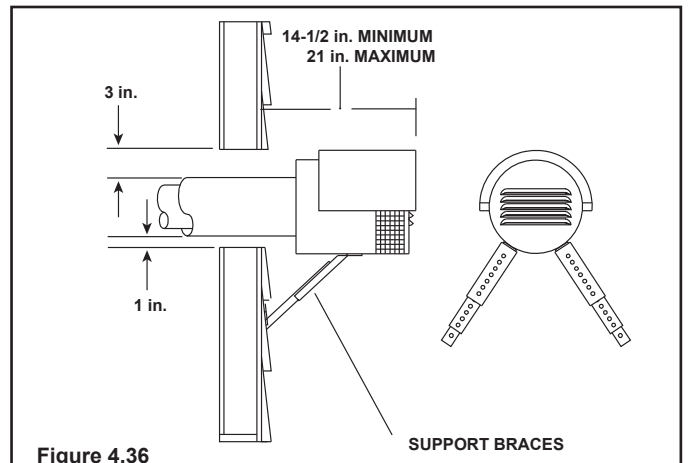

Figure 4.36

## WIRING THE PVK-80 POWER VENT

**NOTE:** Electrical wiring must be done in accordance with national, provincial, and/or local electric codes.

**CAUTION!** Before performing any maintenance, repair, or electrical wiring to the fireplace/power vent, make sure the electrical power is first disconnected to the fireplace/power vent.

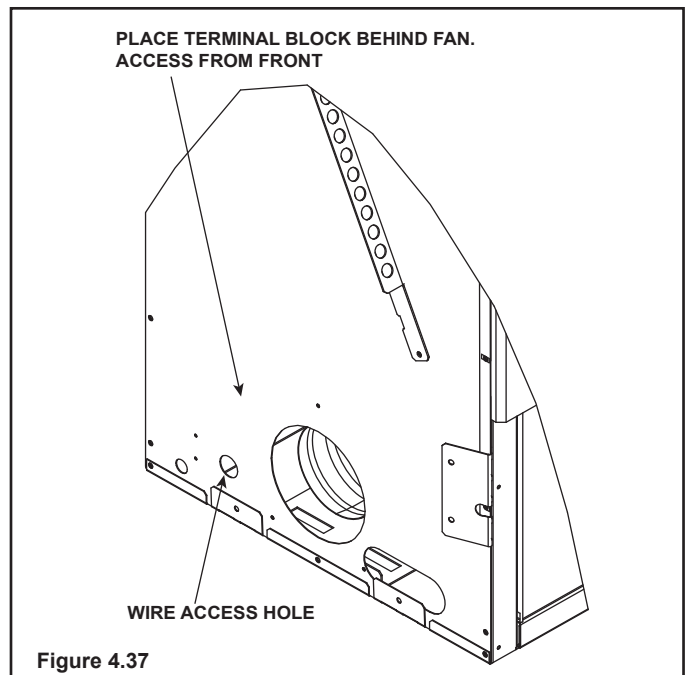
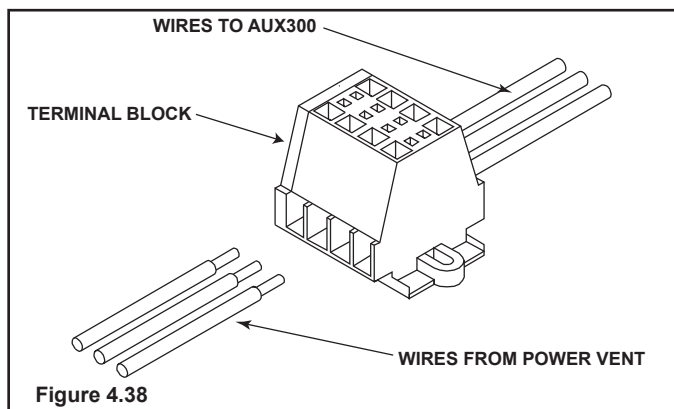

Figure 4.37

**Note:** The PVK-80 Power Vent includes a 6 1/2 foot 5-wire assembly wired into the vent cap blower motor. If this wire assembly will not reach the fireplace, the wires may need to be spliced to additional wire lengths in a junction box installed inside the building. Follow applicable electric codes.

The RED60 appliance comes wired for use with either a PVI-DVP power vent or a PVK-80. If opting to use a PVK-80 power vent, these instructions must be followed carefully to ensure the proper function of the appliance.

1. Refer to RED60-PVK-80 wiring diagram. See Figure 4.39.
2. Remove module heat shield cover plate.
3. Plug the male connectors from wire harness in ACC box onto the red and brown wires on the IPI wire harness. Route the remainder of the harness to where the PVK-80 wiring will enter the appliance.
4. Plug white connector on other harness in ACC box into the AUX2 port of the AUX300 module. Route the remainder of harness to where the PVK-80 wiring will enter the appliance.
5. If required, bore an additional 7/8 inch diameter hole in the side of the fireplace outer wrap near where the wire hole already exists. Use a strain relief connector to secure wires whenever wires pass through a steel panel. See Figure 4.37.
6. Remove and discard wires currently attached to terminal block included with the PVK-80. They are not needed.
7. Place the PVK-80 terminal block assembly in the cavity under the fireplace behind the blower using provided velcro pads. See Figure 4.37. Connect the black, white, and green wires from the power vent assembly to the terminal block according to the wiring diagram. See Figure 4.38 and Figure 4.39. Attach 1/4 inch male wiring connectors to red and brown wires from PVK-80 Power Vent.



8. Plug brown and red wire ends of harness routed in Step 3 onto the brown and red wires from the PVK-80 wiring harness.
9. Connect ends of harness routed in Step 4 to the terminal block, connecting like colors to one another: green to green, white to white, black to black.
10. Replace module heat shield cover plate removed in Step 2.
11. Use a cable tie to connect the wires together so that no wire is in contact with the top of the cavity under the fireplace.
12. Reconnect electrical power supply to the junction box.

## INSTALLATION INSPECTION

1. Follow safety inspection procedures recommended by national, provincial, and/or local codes.
2. Be certain all electrical connections are properly made and secure.
3. Visually inspect the vent system and determine that there is no flue gas spillage, blockage or restriction, leakage, corrosion or other unsafe deficiencies.
4. Place the fireplace in operation and determine that the burner and power vent are operating properly. The main burner should show no signs of floating, lifting, or flashbacks.

**WARNING!** If any unsafe condition is determined when inspecting the installation and operation of the fireplace and Power Vent, the equipment should be shut off. Corrections **MUST** be made before the equipment is put into continuous operation.

## SETTING THE EXHAUST CONTROL

The PVK-80 has an exhaust control lever which must be set and secured during the Installation Inspection. The lever is located behind the electrical cable connector of the cap housing and is factory set in the closed position. See Figure 4.40.

The exhaust control lever must remain in the closed position for optimum appliance performance. Secure the exhaust control lever to the power vent housing with the sheet metal screw. **Do not change this setting.**

**WARNING! Risk of Overheating! DO NOT change exhaust control lever setting! Glass failure will occur.**



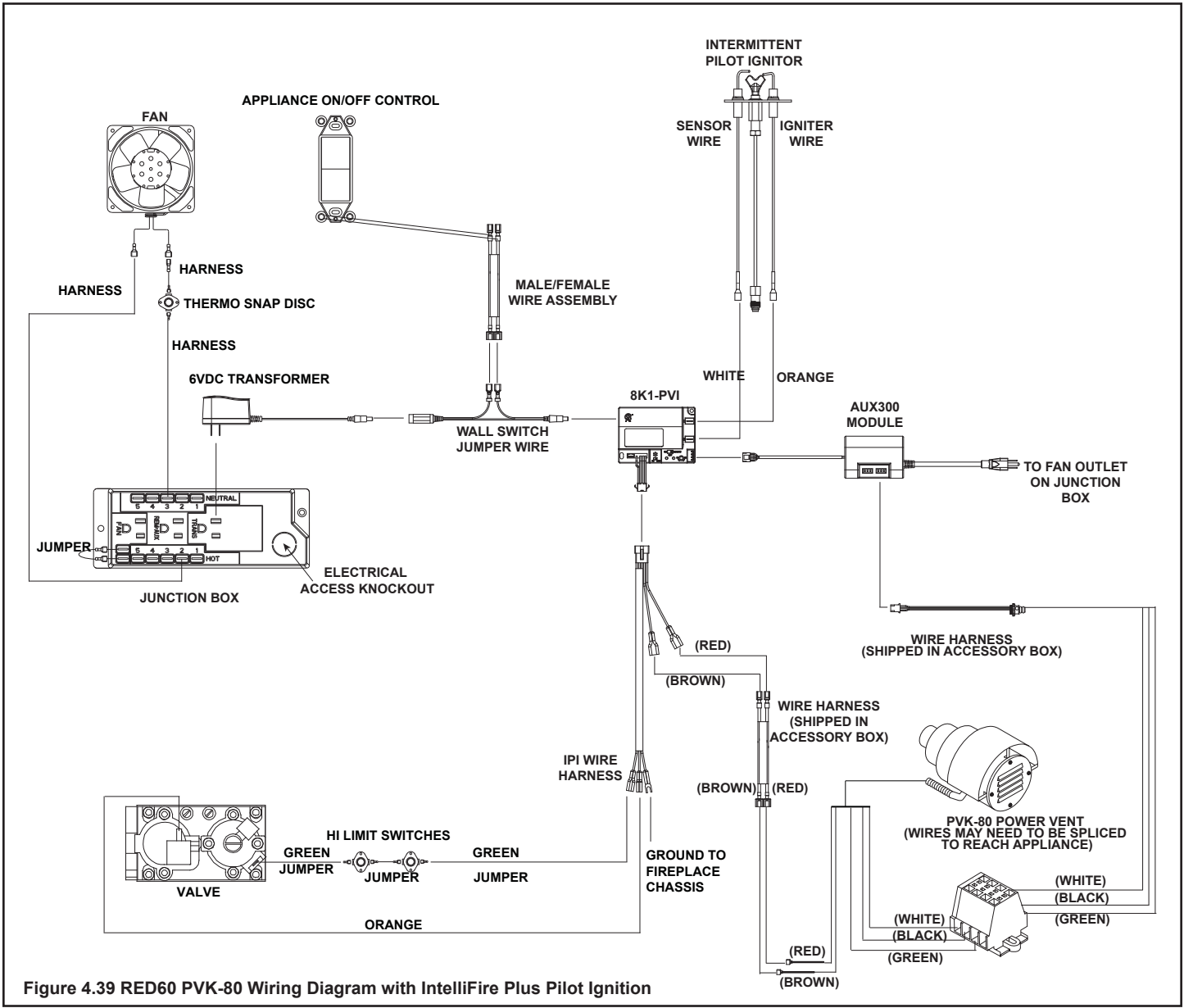

Figure 4.39 RED60 PVK-80 Wiring Diagram with IntelliFire Plus Pilot Ignition

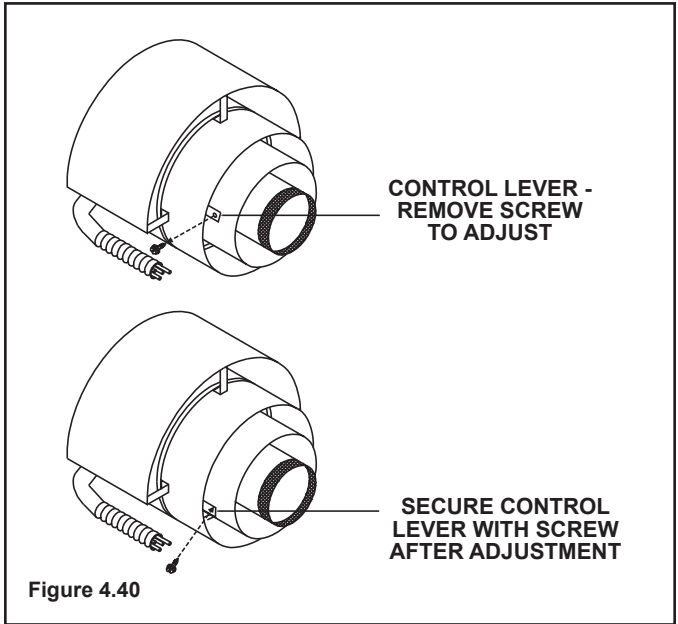

Figure 4.40

## OPERATING INSTRUCTIONS

After installation of the power vent, follow the operation instructions of the fireplace.

1. Turn the fireplace ON/OFF switch to "ON".

**NOTE:** During periods of operation after turning the fireplace "ON", there may be a slight delay before the fireplace ignites. This is due to the time necessary for the blower to reach operating speed and to remove any gases from the combustion chamber.

2. After turning the switch to the "ON" position, if the fireplace does not turn on, shut the switch to "OFF" and inspect the power vent system for any debris that may be obstructing the blower blade movement.
3. Turn the fireplace ON/OFF switch to "OFF" to turn off the burner and the power vent.

## MAINTENANCE

**CAUTION:** Before performing any maintenance or repair to the power vent assembly, make sure electrical power is disconnected to the fireplace.

1. Vent System: Inspect all components and connections annually. Replace, seal, or tighten pipe connections if necessary.
2. Power Vent Cap: Inspect at least annually, to clear away any debris blocking any part of the cap.
3. Motor: The blower motor bearings are sealed and no further lubrication is necessary.

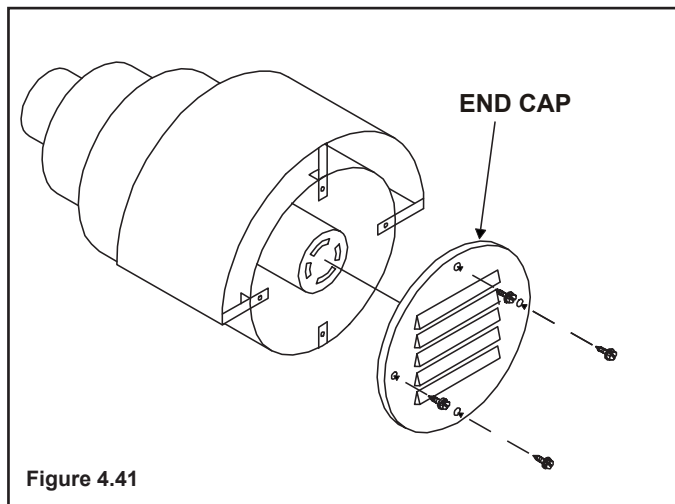

Figure 4.41

## REPLACEMENT PARTS

Replacement parts can be obtained from your dealer. Repair of the Power Vent should only be done by a qualified service person.

### 1. ACCESS TO THE VACUUM SWITCH, TEFLON TUBING, AND BLOWER MOTOR:

- A. Turn power to off. Remove end cap by removing the four (4) sheet metal screws. See Figure 4.41.
- B. Unplug the two wires connected to the vacuum switch and the two wires connected to the blower motor.
- C. Loosen and remove the nut for the right angle connector

and carefully pull back the cable to remove the four (4) wires from the power vent assembly.

- D. With the cable loosened from the power vent assembly, remove the sheet metal screws used to secure the power vent assembly in place. Firmly support the assembly to prevent the unit from falling after the sheet metal screws have been removed. See Figure 4.42.

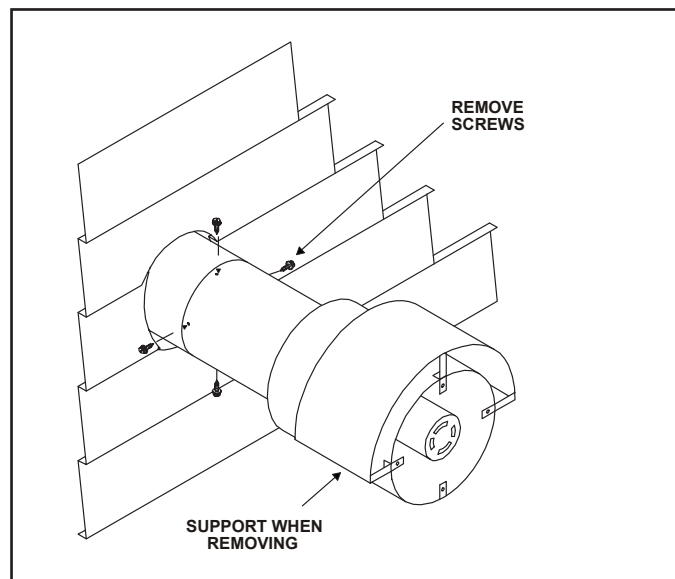

Figure 4.42

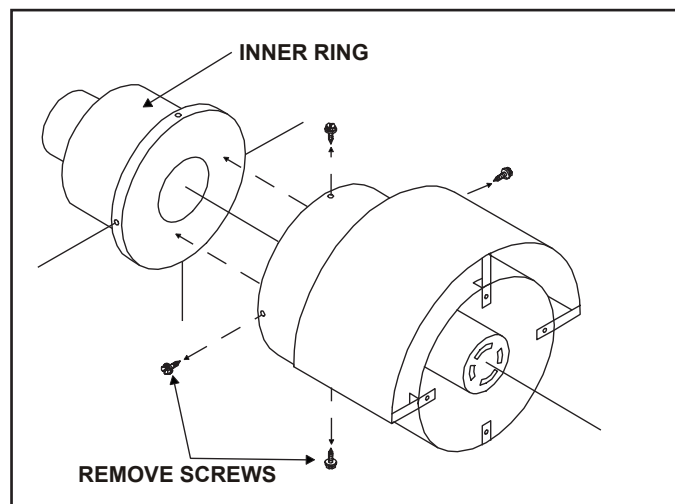

Figure 4.43

- E. Remove the sheet metal screws from the 10-1/2 in. diameter pipe and remove the inner ring from inside the collar. See Figure 4.43.

**IMPORTANT:** Take special note of the orientation of the two part assembly. The inner ring must be returned to its original position for correct Power Vent operation.

- F. Remove the wire mesh that is covering the exhaust port hole by removing the 4 sheet metal screws.
- G. Bend the metal guide plate at the exhaust port hole out and through the hole on the 10-1/2 in. diameter collar. See Figure 4.44.

**Note:** On some caps, the metal guide plate is attached to the wire mesh and will slide out with the mesh.

H. Slide the blower assembly out of the 10-1/2 in. diameter collar for maintenance or replacement.

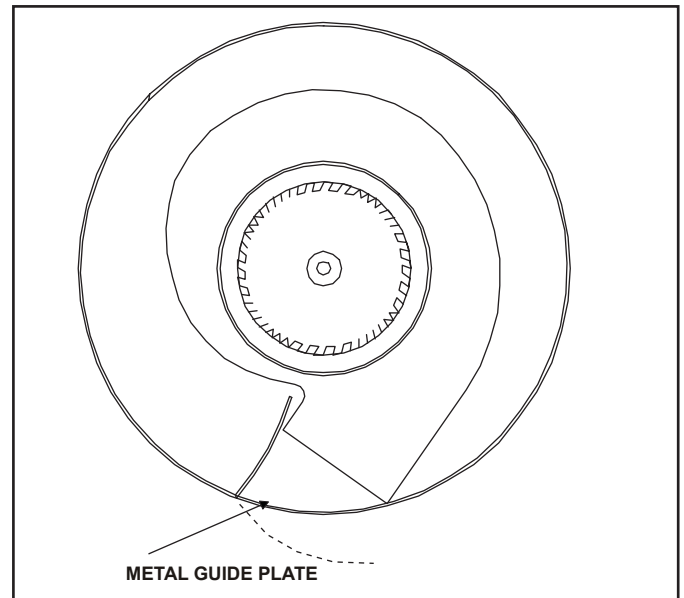
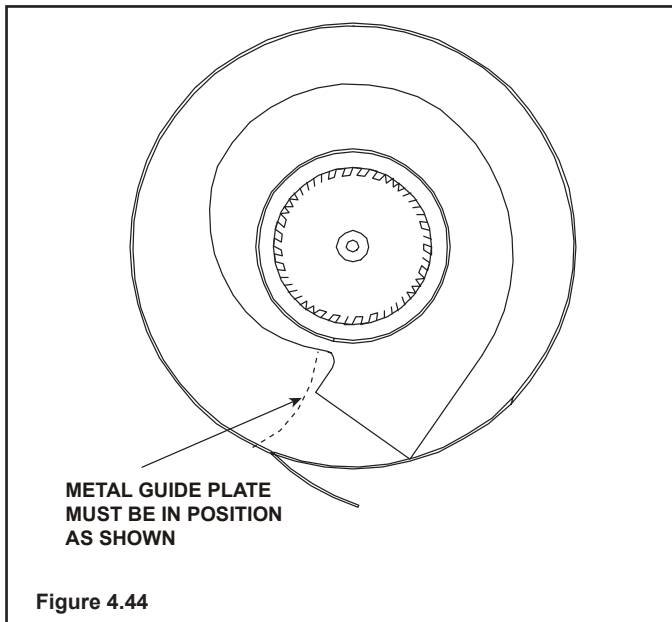

Figure 4.46

E. Secure the cap assembly to the last vent pipe section. Position the power vent assembly with the exhaust air directed downward to ensure proper operation.

F. Feed the four (4) wires back through the hole on the collar and tighten the nut on the right angle connector. Reconnect the brown and red wire to the vacuum switch and connect the black and white wires to the fan motor.

**CAUTION:** Make sure the cable is **NOT** in the path of the hot exhaust air. This can cause the wire insulation to melt and the Power Vent to malfunction.

G. Reattach the end cap to the cap assembly with four (4) sheet metal screws. Position the end cap with the louvers pointed downward (horizontal termination).

H. Reconnect the electrical power to the fireplace and turn the fireplace ON/OFF switch "ON" to ensure proper operation of the fireplace and power vent.

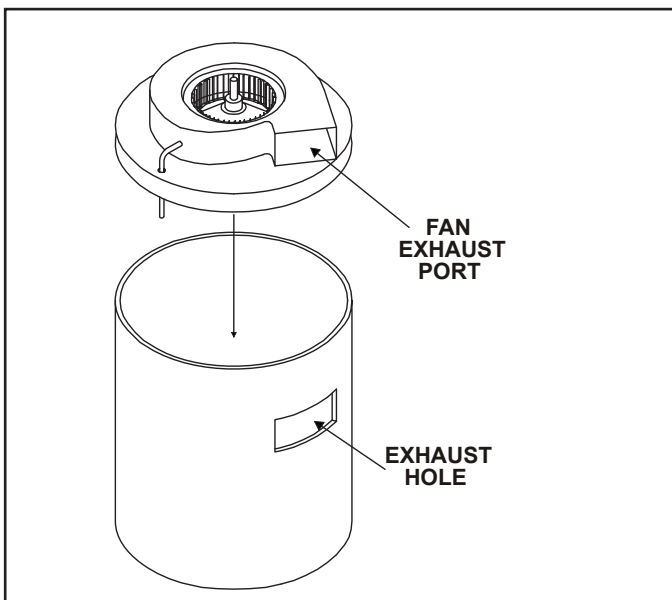

Figure 4.45

## 2. TO REASSEMBLE THE POWER VENT:

A. Slide the fan assembly into the 10-1/2" diameter collar, making sure that the exhaust port on the fan assembly lines up with the exhaust hole cut in the 10-1/2" diameter collar. See Figure 4.45.

B. The metal exhaust guide plate will have to be bent back inside the fan assembly. See Figure 4.46.

C. Fasten the wire mesh to the 10-1/2" collar to cover the exhaust port hole, using (4) sheet metal screws.

D. Slide the inner ring inside the cap assembly, carefully positioning the inner ring to its original orientation. See Figure 4.47. Carefully align the screw holes on the 10-1/2" diameter collar and the inner ring.

**NOTE:** This inner ring must be returned to its correct orientation with the 10-1/2" collar for proper fan operation.

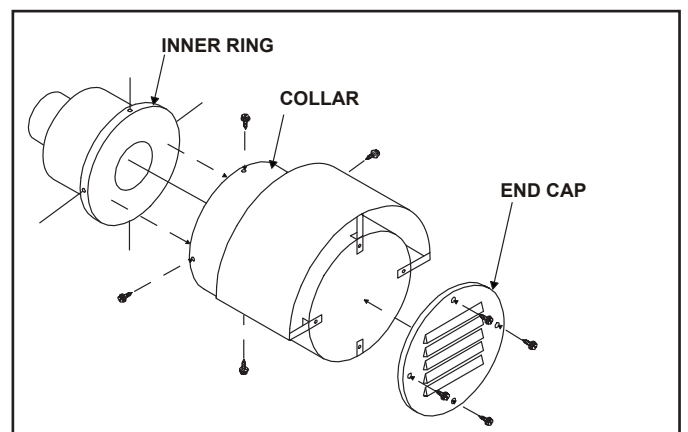

Figure 4.47

## ⚠ WARNING



Fire Risk. Explosion Risk.

Do NOT pack insulation or other combustibles between ceiling firestops.

- ALWAYS maintain specified clearances around venting and firestop systems.
- Install wall shield and ceiling firestops as specified.

Failure to keep insulation or other material away from vent pipe could cause fire.

### PVK-80 Top Vent - Horizontal Termination Venting with 1 elbow

$V_1$ Minimum		$V_1 + H_1$ Maximum	
2 ft.	610 mm	30 ft.	9.1 m
3 ft.	914 mm	40 ft.	12.1 m
4 ft.	1.2 m	50 ft.	15.2 m
$V_1 + H_1 = 50 \text{ ft. (15.2 m)}$ Maximum			

**Note:** Must have 24 inches minimum vertical vent prior to attaching any elbow to the appliance.

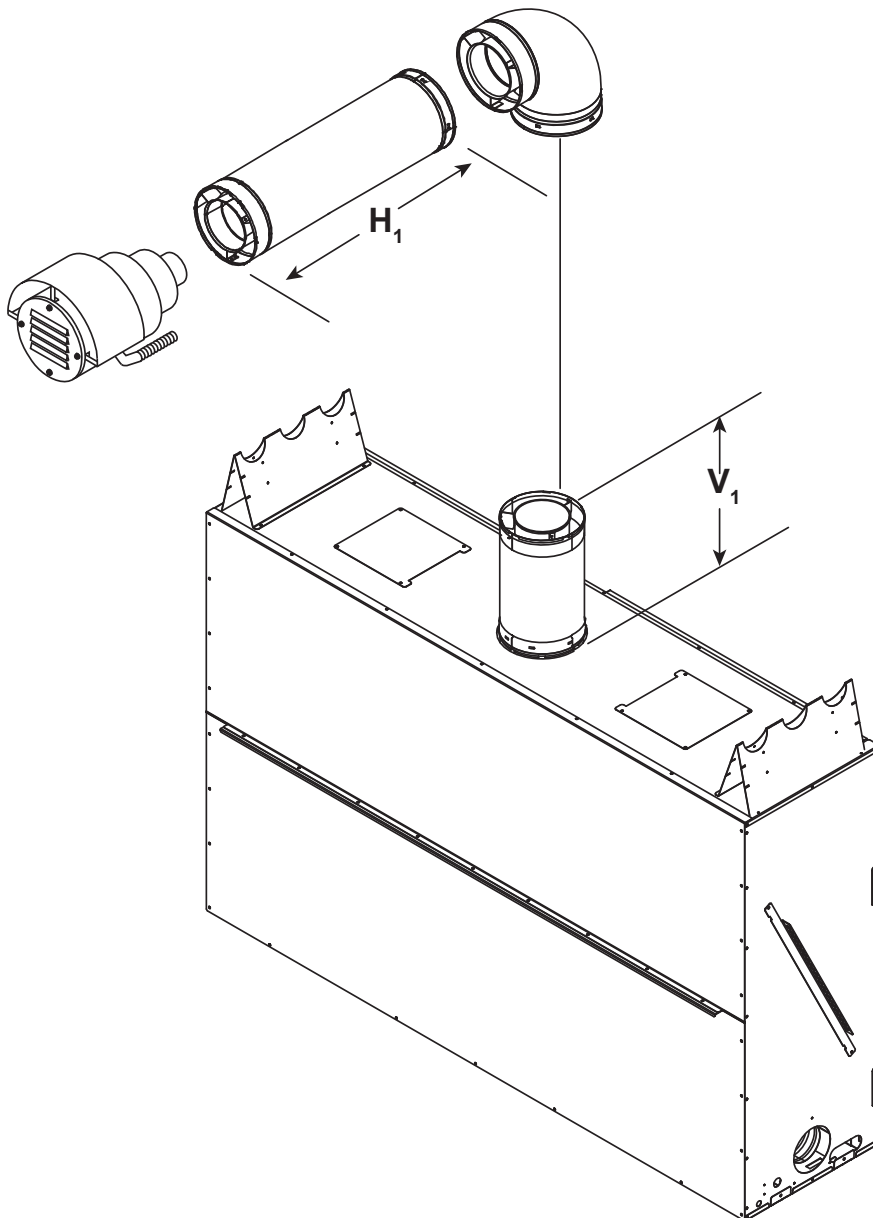

Figure 4.48

## PVK-80 Top Vent - Horizontal Termination Venting with 2 elbows

V <sub>1</sub> Minimum		V <sub>1</sub> + H <sub>1</sub> + H <sub>2</sub> Maximum	
2 ft.	610 mm	20 ft.	6 m
3 ft.	914 mm	30 ft.	9.1 m
4 ft.	1.2 m	40 ft.	12.1 m
V <sub>1</sub> + H <sub>1</sub> + H <sub>2</sub> = 40 ft. (12.1 m) Maximum			

**Note:** Must have 24 inches minimum vertical vent prior to attaching any elbow to the appliance.

**Note:** Use DVP Series components only.

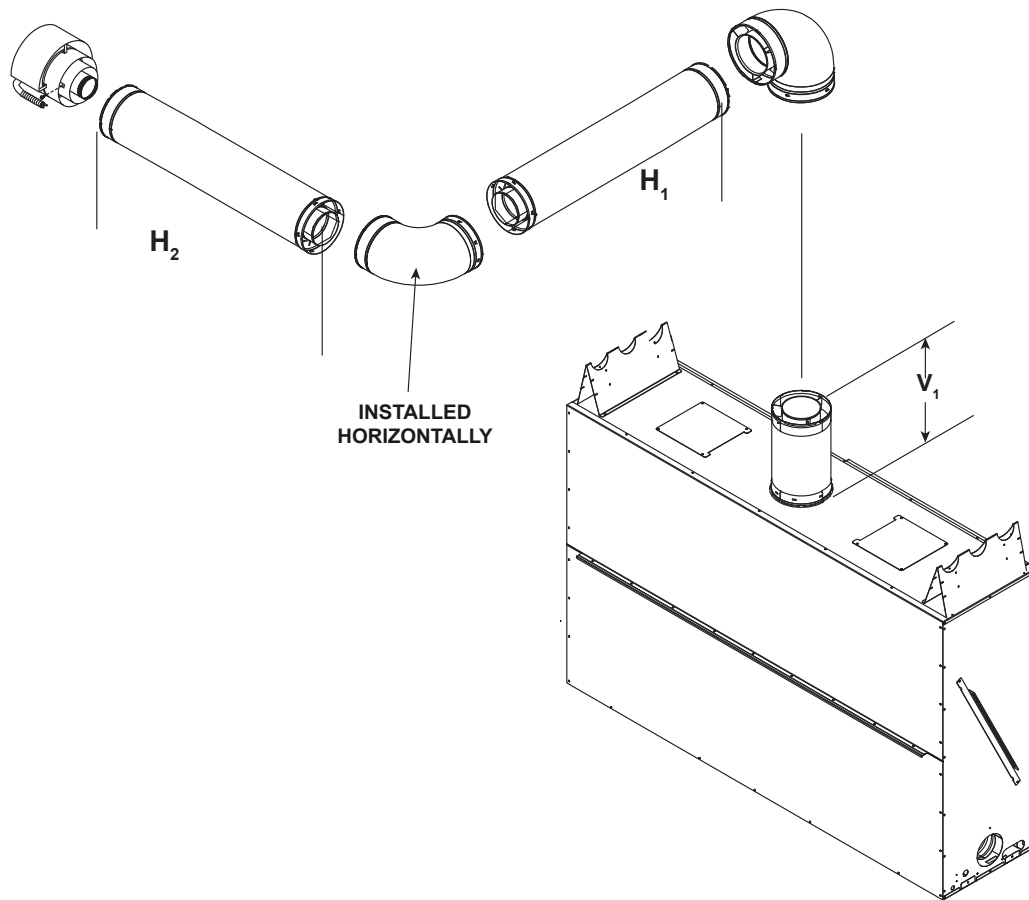

Figure 4.49

## PVK-80 Top Vent - Horizontal Termination Venting with 3 or more elbows

3 Elbows			
V <sub>1</sub> + V <sub>2</sub> Minimum		Total V + Total H Maximum	
2 ft.	610 mm	20 ft.	6 m
3 ft.	914 mm	30 ft.	9.1 m
4 ft.	1.2 m	40 ft.	12.1 m
Total V + Total H = 40 ft. (12.1 m) Maximum			

**Note:** Use DVP Series components only.

**Note:** Must have 24 inches minimum vertical vent prior to attaching any elbow to the appliance.

4 Elbows			
V <sub>1</sub> + V <sub>2</sub> Minimum		Total V + Total H Maximum	
2 ft.	610 mm	20 ft.	6 m
3 ft.	914 mm	25 ft.	7.6 m
4 ft.	1.2 m	30 ft.	9.1 m
Total V + Total H = 30 ft. (9.1 m) Maximum			

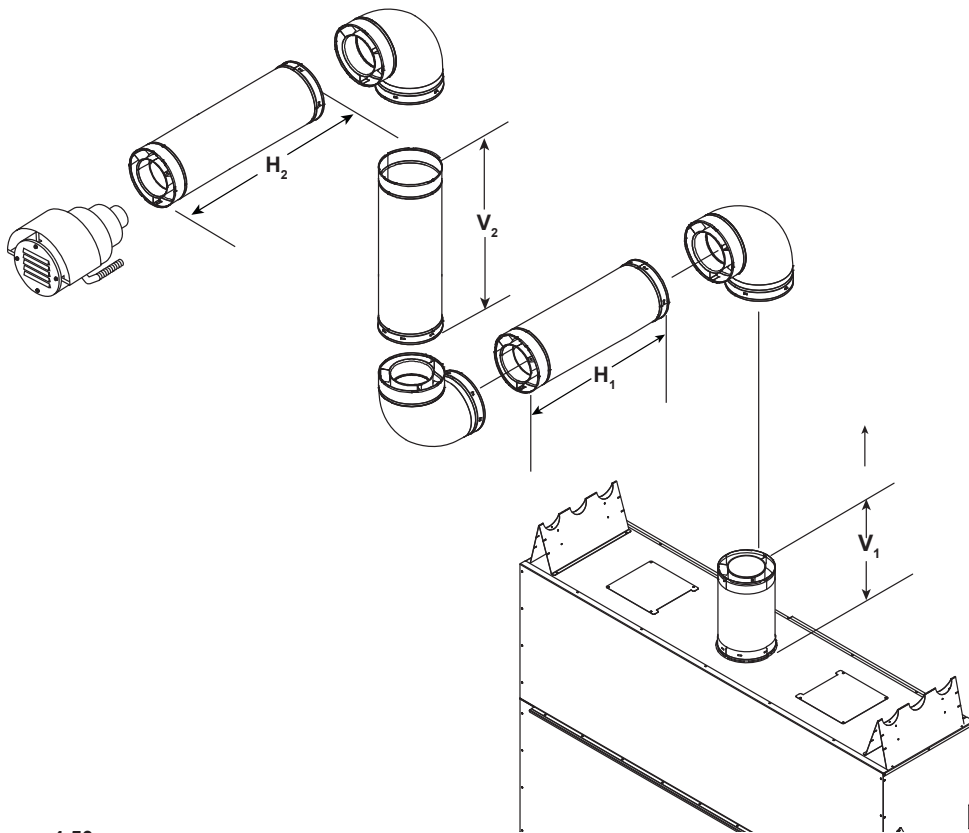
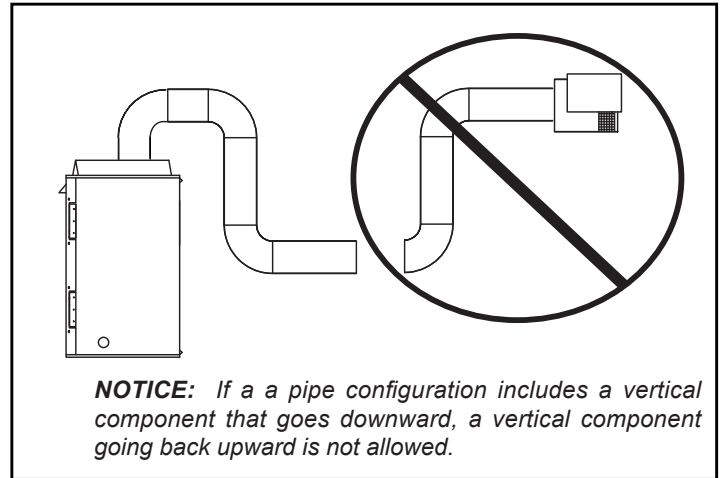
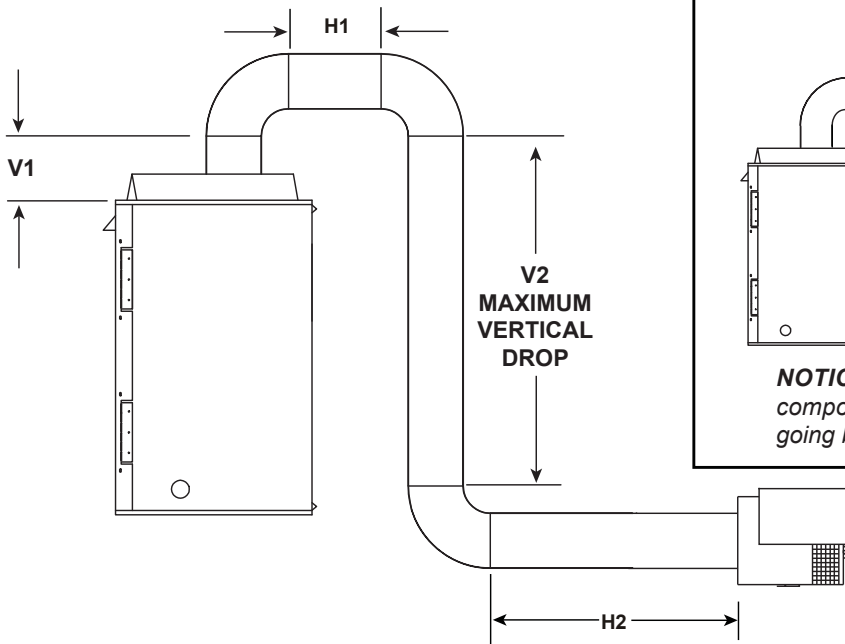

Figure 4.50



**Note:** 1 ft. of vertical drop decreases horizontal length by 2 ft.



**NOTE:** Maximum total vent run= Total vertical vent run + Total horizontal vent run

**DIRECT VENT WITH 2 FT. MINIMUM VERTICAL ( $V_1$ ) OFF TOP OF APPLIANCE**

MAX. ELBOWS (45° & 90°)	MAX. TOTAL VENT RUN (FT.) Total V + Total H	MAX. VERT. DROP (FT.) $V_2$
3	24 ft.	7 ft.
4	17 ft.	7 ft.

\*1 ft. vertical drop decreases horizontal length by 2 ft.

**DIRECT VENT WITH 3 FT. MINIMUM VERTICAL ( $V_1$ ) OFF TOP OF APPLIANCE**

MAX. ELBOWS (45° & 90°)	MAX. TOTAL VENT RUN (FT.) Total V + Total H	MAX. VERT. DROP (FT.) $V_2$
3	29 ft.	7 ft.
4	22 ft.	7 ft.

\*1 ft. vertical drop decreases horizontal length by 2 ft.

**DIRECT VENT WITH 4 FT. MINIMUM VERTICAL ( $V_1$ ) OFF TOP OF APPLIANCE**

MAX. ELBOWS (45° & 90°)	MAX. TOTAL VENT RUN (FT.) Total V + Total H	MAX. VERT. DROP (FT.) $V_2$
3	34 ft.	7 ft.
4	26 ft.	7 ft.

\*1 ft. vertical drop decreases horizontal length by 2 ft.

**EXAMPLE:** An appliance with 4 ft. vertical off the top ( $V_1$ ), a vertical drop of 3 ft. ( $V_2$ ) and a total of 3 elbows can have a maximum vent run length (Total V + Total H) of 28 ft.

$$34 \text{ ft.} - (3 \text{ ft vertical drop} \times 2^*) = 28 \text{ ft.}$$

Figure 4.51

# 5 Vent Clearances and Framing

## A. Pipe Clearances to Combustibles

**WARNING! Risk of Fire! Maintain air space clearance to vent. DO NOT pack insulation or other combustibles:**

- Between ceiling firestops
- Between wall shield firestops
- Around vent system

Failure to keep insulation or other material away from vent pipe could cause overheating and fire.

Note: Heat shields MUST overlap by a minimum of 1-1/2 in. (38 mm).  
 • DVP heat shield - designed to be used on a wall 4 in. to 7-1/4 in. (102 mm to 184 mm) thick.  
 • If wall thickness is less than 4 in. the existing heat shields must be field trimmed. If wall thickness is greater than 7-1/4 in. a DVP-HSM-B will be required.

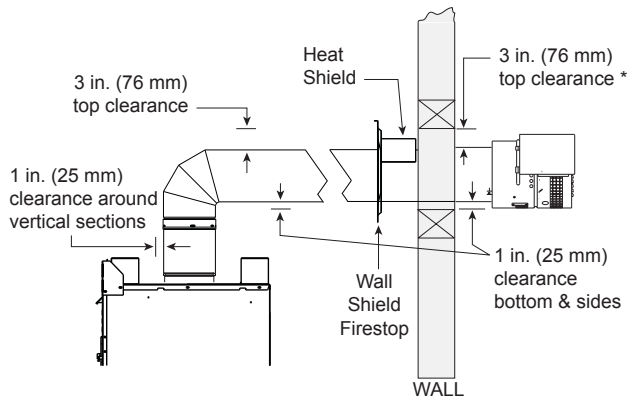

Figure 5.1 Horizontal Venting Clearances To Combustible Materials

## B. Wall Penetration Framing

### Combustible Wall Penetration

Whenever a combustible wall is penetrated, you must frame a hole for the wall shield firestop(s). The wall shield firestop maintains minimum clearances and prevents cold air infiltration.

- The opening must be framed on all four sides using the same size framing materials as those used in the wall construction.
- DVP pipe - A wall shield firestop must be placed on each side of an interior wall. A minimum 1-1/2 in. (38 mm) overlap of attached heat shields must be maintained.
- See Section 7.F for information for regarding the installation of a horizontal termination cap.

### Non-Combustible Wall Penetration

If the hole being penetrated is surrounded by noncombustible materials such as concrete, a hole with diameter one inch greater than the pipe is acceptable.

Whenever a non-combustible wall is penetrated, the wall shield firestop is only required on one side and no heat shield is necessary.

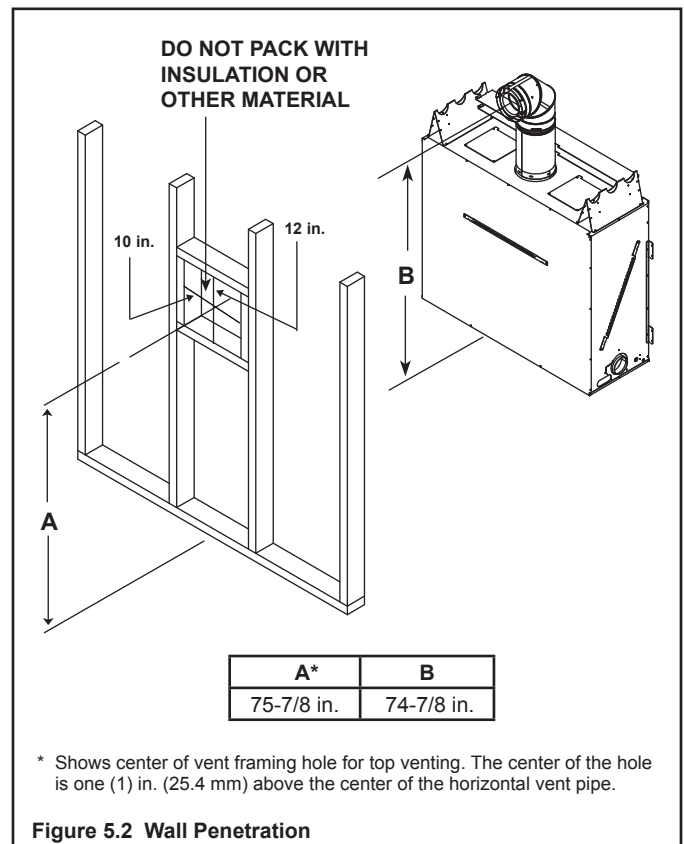

Figure 5.2 Wall Penetration

### C. Ceiling Firestop/Floor Penetration Framing

A ceiling firestop **MUST** be used between floors and attics.

- **DVP pipe only** - Frame an opening 10 in. by 10 in. (254 mm by 254 mm) whenever the vent penetrates a ceiling/floor (see Figure 5.3).
- Frame the area with the same sized lumber as used in ceiling/floor joist.
- The ceiling firestop may be installed above or below the ceiling joists when installed with an attic insulation shield. It must be under joists between floors that are not insulated. Refer to Figure 5.4.
- Secure with three fasteners on each side.

**WARNING! Risk of Fire! DO NOT pack insulation around the vent. Insulation must be kept back from the pipe to prevent overheating.**

### D. Install Attic Insulation Shield

**WARNING! Fire Risk. DO NOT allow loose materials or insulation to touch vent. Hearth & Home Technologies requires the use of an attic shield.**

The International Fuel Gas Code requires an attic shield constructed of 26 gauge minimum steel that extends at least 2 in. (51 mm) above insulation.

- Attic insulation shields must meet specified clearances to combustible materials and be secured in place.
- An attic insulation shield kit is available from Hearth & Home Technologies. Contact your dealer to order. Install attic insulation shield according to instructions included with kit.

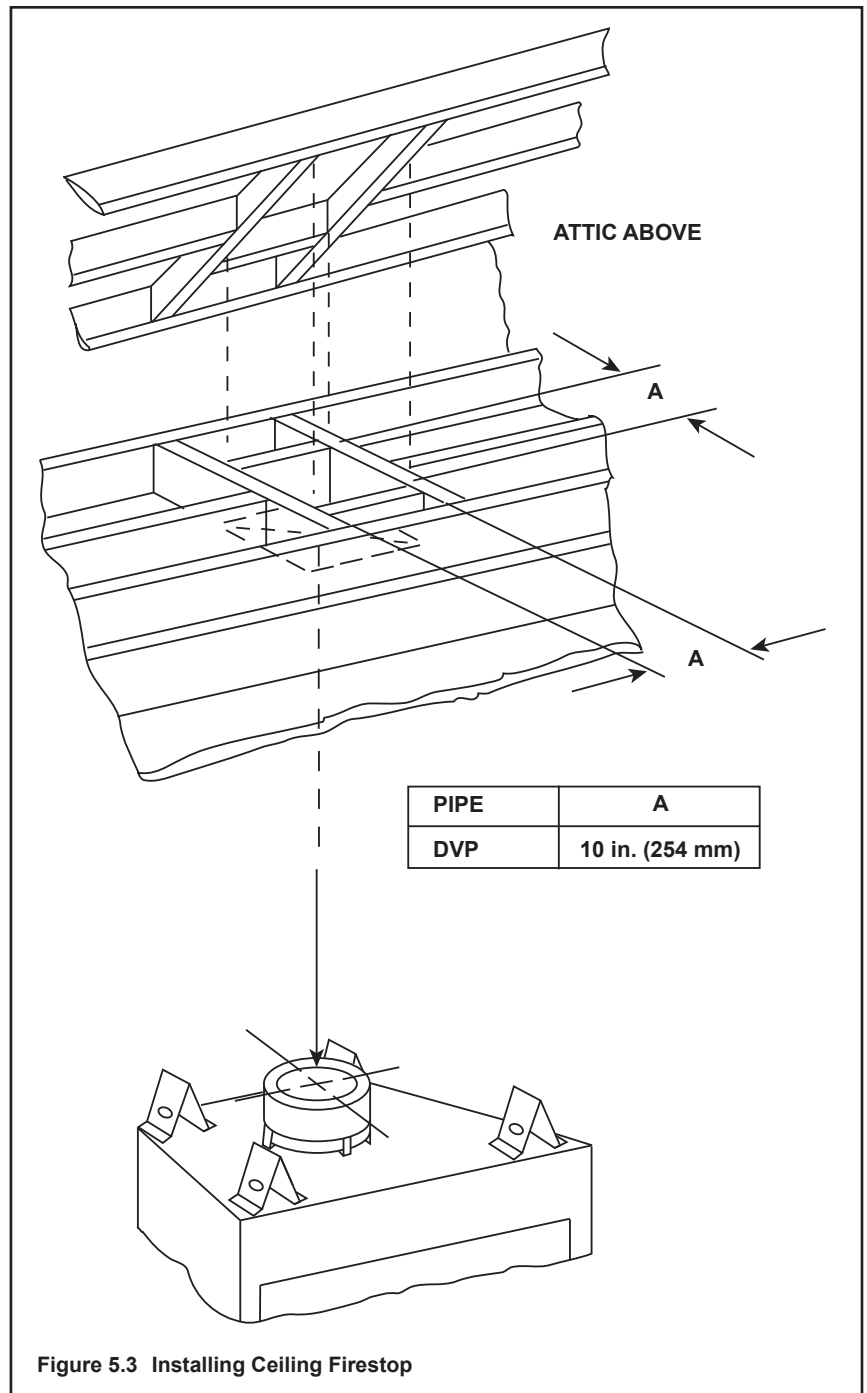

Figure 5.3 Installing Ceiling Firestop

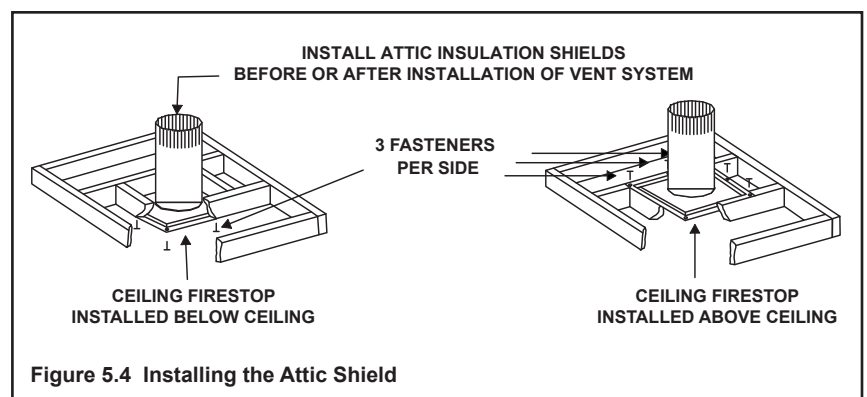

Figure 5.4 Installing the Attic Shield

# 6 Appliance Preparation

## A. Vent Collar Preparation

**CAUTION! Risk of Cuts, Abrasions or Flying Debris.** Wear protective gloves and safety glasses during installation. Sheet metal edges are sharp.

1. Remove seal cap by lifting up and off of the starting collar.
2. Place first twenty-four inch vent section on the starting collar.

**WARNING! Risk of Fire! A MINIMUM of twenty-four inches vertical pipe is required prior to attaching any elbow to the appliance.**

3. Place fiberglass rope ring over initial twenty-four inch vent section and position tightly to top of appliance.
4. Remove bottom metal panel by removing six screws. Screw locations are shown in Figure 6.1. All screws are located behind the panel: four on the bottom and one on each side. Remove all six screws and gently lift the panel off the appliance avoiding contact with the non-combustible board if possible.

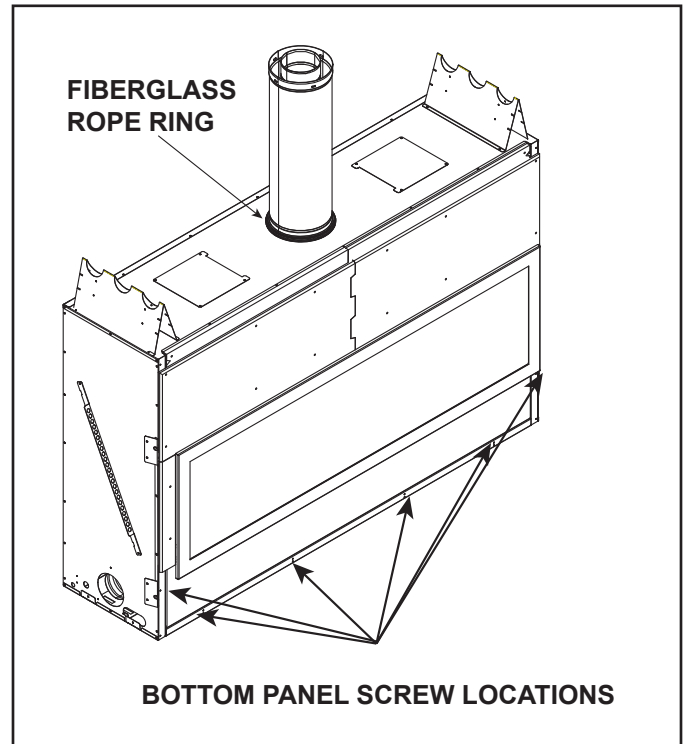

Figure 6.1 Location of Fiberglass Rope Ring

## B. Securing and Leveling the Appliance

**WARNING! Risk of Fire! Prevent contact with:**

- Sagging or loose insulation
- Insulation backing or plastic
- Framing and other combustible materials

Block openings into the chase to prevent entry of blown-in insulation. Make sure insulation and other materials are secured.

**DO NOT** notch the framing around the appliance standoffs. Failure to maintain air space clearance could cause overheating and fire.

Figure 6.2 shows how to properly position, level and secure the appliance. Nailing tabs are provided to secure the appliance to the framing members.

- Bend out the two nailing tabs on each side.
- Place the appliance into position.
- Keep nailing tabs flush with the framing. See Figure 3.4.
- Level the appliance from side to side and front to back.
- Shim the appliance as necessary. It is acceptable to use wood shims underneath the appliance.
- Secure the appliance to the framing by using nails or screws through the nailing tabs.

Figure 6.2 shows the fireplace installed on the floor. However, this fireplace can be elevated off the floor provided that the fireplace is properly supported by framing materials and the ceiling clearances are maintained.

## Setting the Fireplace into the Framing

The left and right nailing tabs were designed as a means to ensure the fireplace is mounted flush with the framing materials.

Bend out all four nailing tabs. Screw or nail each nailing tab to the adjoining framing material. Ensure that the one inch air space clearance is maintained on the sides and back of the fireplace. See Figure 6.3 and Figure 6.4.



Figure 6.3 Nailing Tabs Shipping Position



Figure 6.4 Nailing Tabs Installation Position

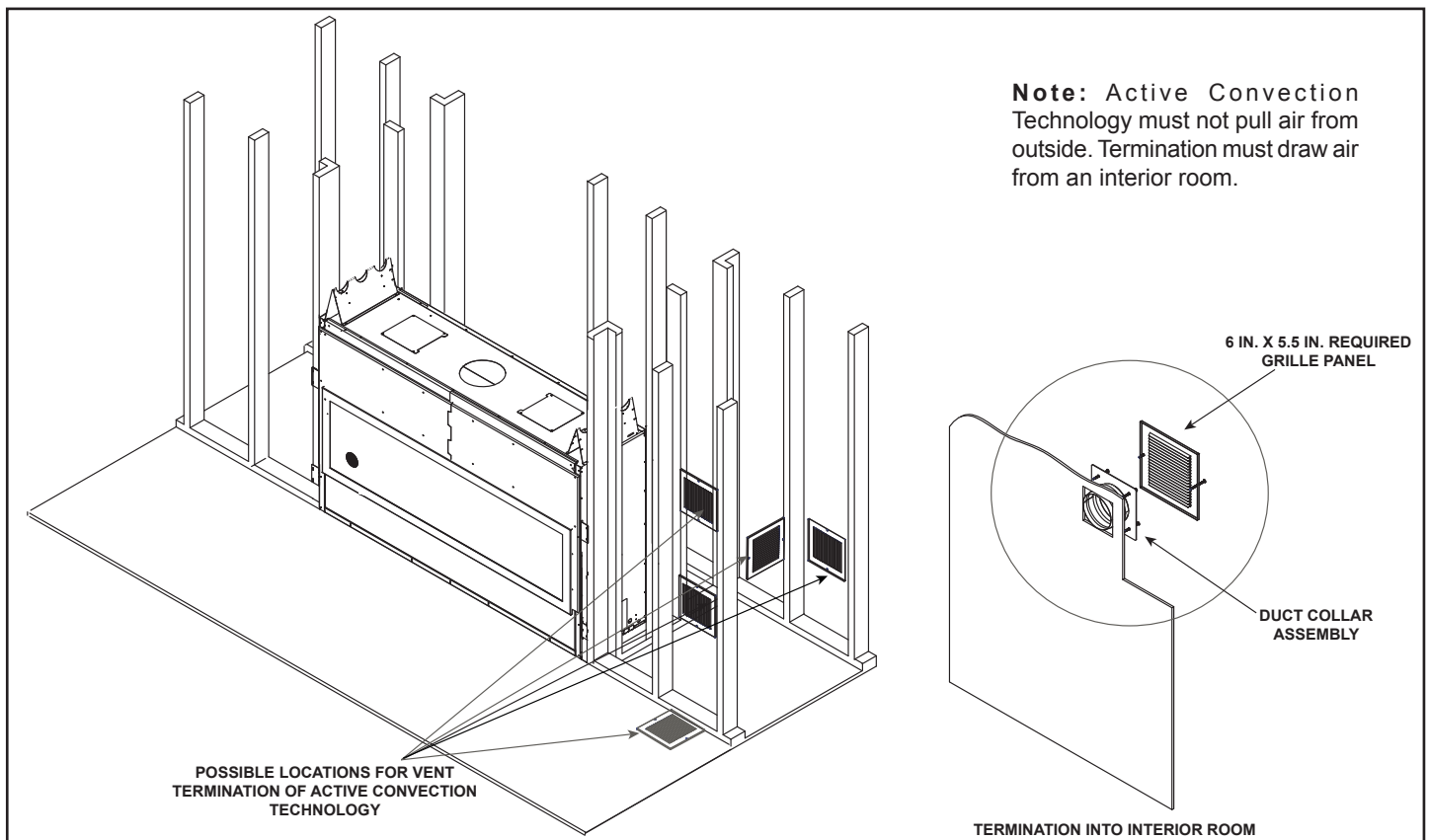

Figure 6.2 Proper Positioning, Leveling And Securing Of An Appliance

## C. Active Convection Technology

The fireplace appliance has been provided with an active convection blower. The blower is required to keep lower control chamber component temperatures at an ideal operating temperature. The blower also provides for more efficient use of appliance heat by assisting the convection air around the firebox and back into the room. A four inch flexible duct kit has been provided with the appliance. One end of the flex duct will connect to the fan bracket assembly located in the lower control chamber. See Figure 6.5, Detail A. The other end will terminate to an interior wall of the house. The intake grille panel provided with the appliance must be used. See Figure 6.5 and Figure 6.6.

**Note:** The blower is essential for keeping components and the appliance environment in safe operating temperatures.

**Note:** Refer to Section 8.B if the active convection blower is to be moved to the right side.

**WARNING! Risk of Fire! DO NOT terminate blower vent into an attic, crawl space, or the appliance chase. Vent must terminate on an adjacent, interior wall.**

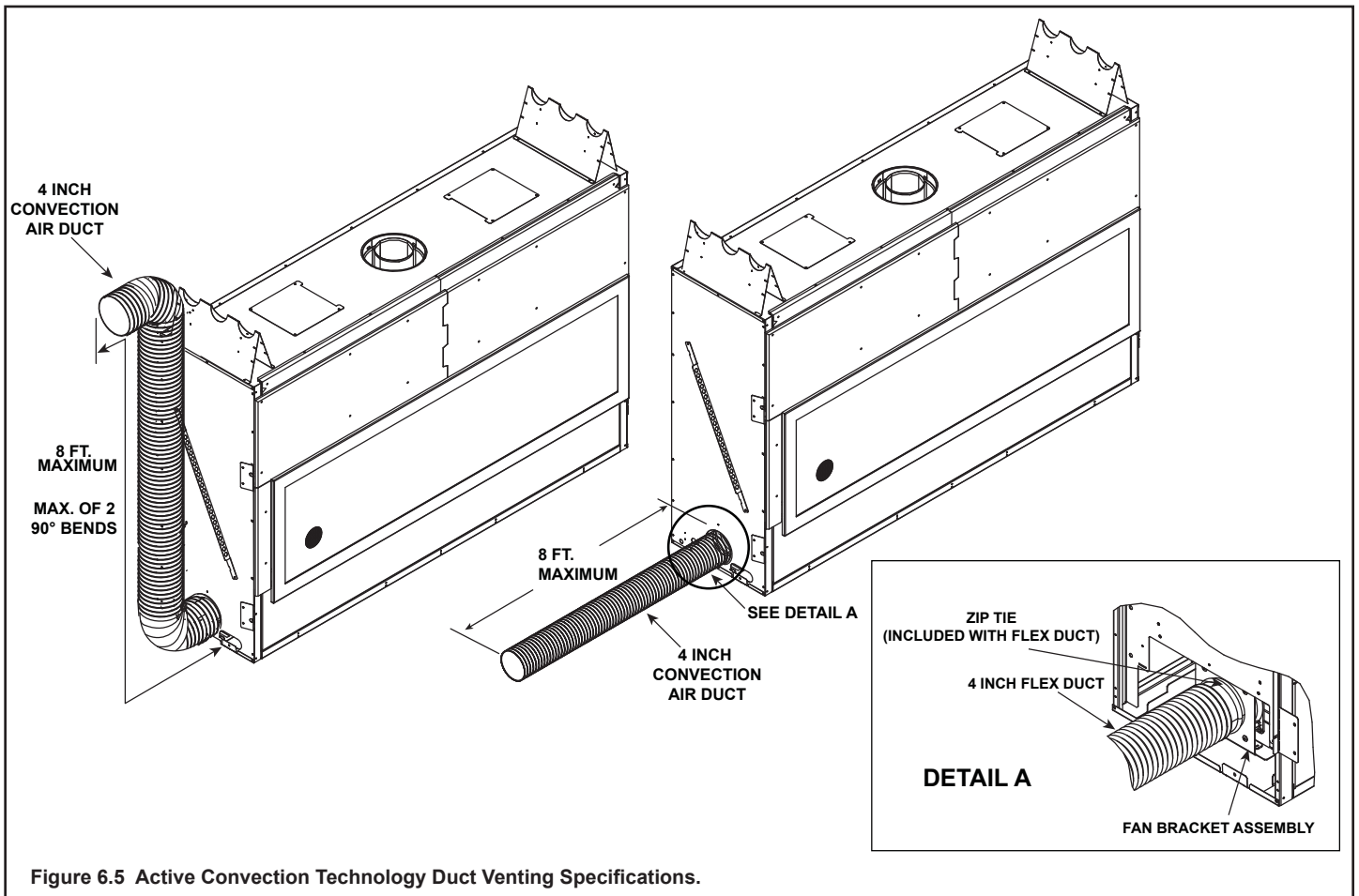
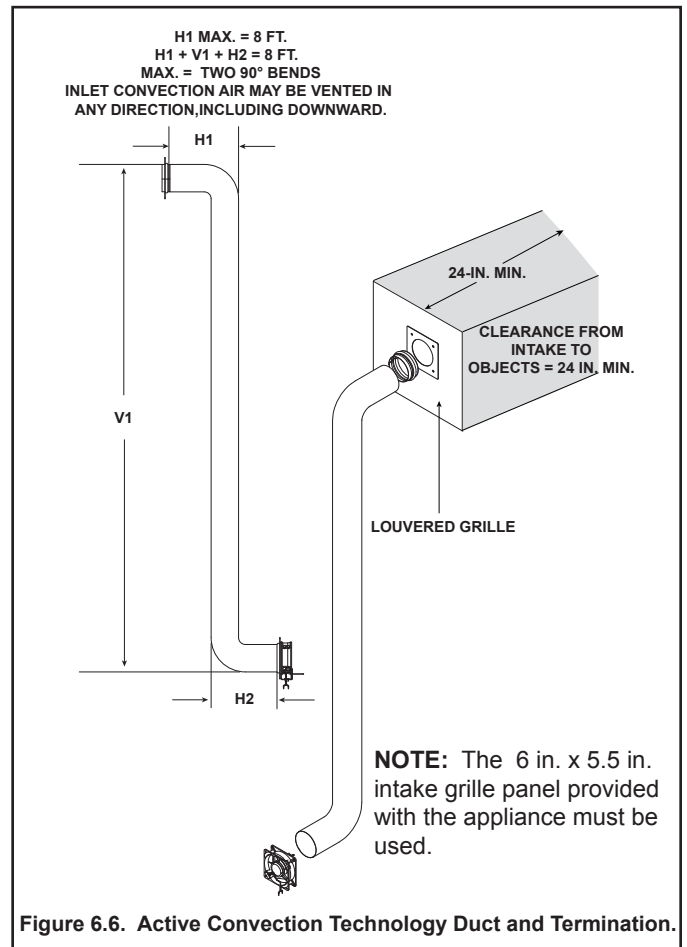



# 7 Venting and Chimneys

## A. Assemble Vent Sections

### Attach Vent to the Firebox Assembly

**Note:** The end of the pipe sections with the lanced tabs will face toward the appliance.

Attach the first pipe section to the starting collar:

- Lanced pipe end of the starting collar.
- Inner pipe over inner collar.
- Push the pipe section until all lanced tabs snap in place.
- Lightly tug on pipe to confirm it has locked.

### Required Commercial, Multi-family (Multi-level exceeding two stories), or High-Rise Applications

All outer pipe joints must be sealed with 100% silicone (300° F minimum continuous exposure rating), including the slip section that connects directly to the horizontal termination cap.

- Apply a bead of silicone sealant (300° F minimum continuous exposure rating) inside the female outer pipe joint prior to joining sections. See Figure 7.1.
- Only outer pipes need to be sealed. All unit collar, pipe, slip section, elbow and cap outer flues shall be sealed in this manner, unless otherwise stated.

**WARNING! Risk of Fire or Explosion! DO NOT break silicone seals on slip sections. Use care when removing termination cap from slip pipe. If slip section seals are broken during removal of the termination cap, vent could leak.**

### Assemble Pipe Sections

Per Figure 7.2:

- Start the inner pipe on the lanced end of section A into the flared end of section B.
- Start the outer pipe of section A over the outer pipe of section B.
- Once both vents sections are started, push firmly until all lanced tabs lock into place.
- Lightly tug on the pipe to confirm the tabs have locked.

It is acceptable to use screws no longer than 1/2 in. (13 mm) to hold outer pipe sections together. If predrilling holes, **DO NOT** penetrate inner pipe.

For 90° and 45° elbows that are changing the vent direction from horizontal to vertical, one screw minimum should be put in the outer flue at the horizontal elbow joint to prevent the elbow from rotating. Use screws no longer than 1/2 in. (13 mm). If predrilling screw holes, **DO NOT** penetrate inner pipe.



Figure 7.1 High Temperature Silicone Sealant

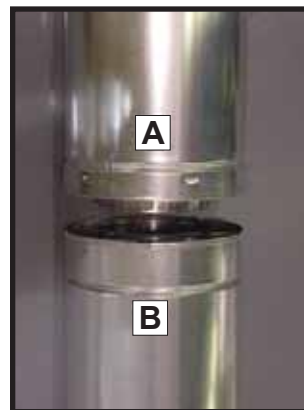

Figure 7.2



Figure 7.3

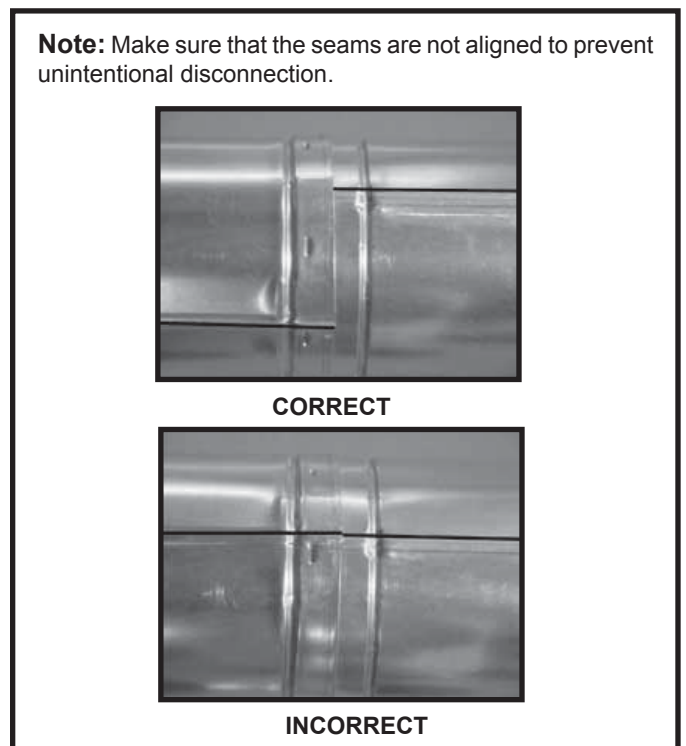

Figure 7.4 Seams

## B. Assemble Slip Sections

- Slide the inner flue of the slip section into the inner flue of the pipe section and the outer flue of the slip section over the outer flue of the pipe section. See Figure 7.5.
- Slide together to the desired length.

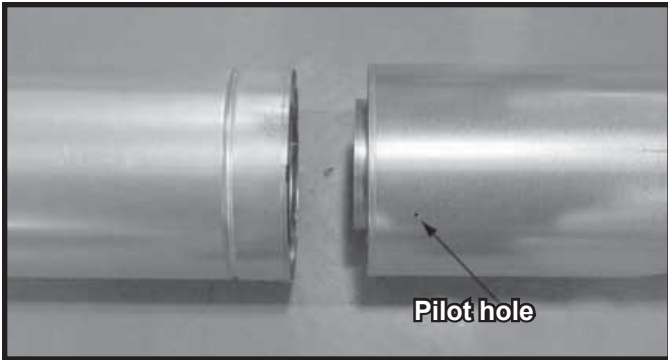

Figure 7.5 Slip Section Pilot Holes

- Maintain a 1-1/2 in. (38 mm) overlap between the slip section and the pipe section.
- Secure the pipe and slip section with two screws no longer than 1/2 in. (13 mm), using the pilot holes in the slip section. See Figure 7.6.

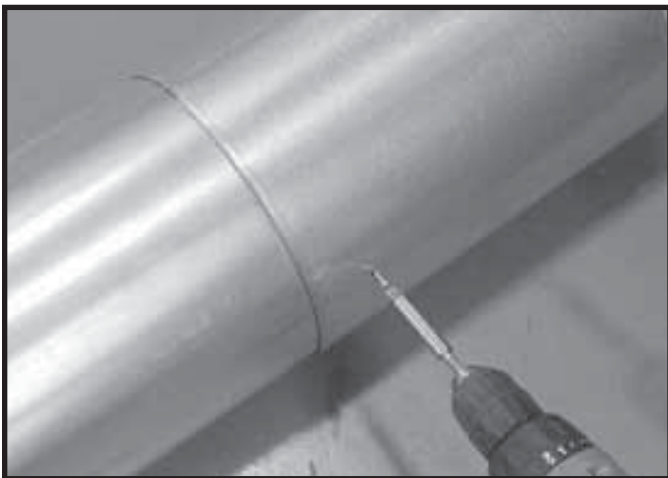

Figure 7.6 Screws into Slip Section

- Continue adding pipe as necessary following instructions in “Assembling Pipe Sections.”

**NOTICE:** If slip section is too long, the inner and outer flues of the slip section can be cut to the desired length.

**NOTICE:** When installing a vent system with an HRC termination cap, all pipe system joints shall be sealed using a silicone sealant with a minimum of 300°F continuous exposure rating.

- Apply a bead of silicone sealant inside the female outer pipe joint prior to joining sections.
- Only outer pipes are sealed, sealing the inner flue is not required.
- All unit collar, pipe, slip section, elbow and cap outer flues shall be sealed.

## C. Secure The Vent Sections

- Vertical runs originating off the top of the appliance, with no offsets, must be supported every 8 ft. (2.44 m) after the maximum allowed 25 ft. (7.62 m) of unsupported rise.
- Vertical runs, after any elbow, must be supported every 5 ft. (1.52 m).
- Horizontal runs must be supported every 5 feet (1.52 m).
- Vent supports or plumbers strap (spaced 120° apart) may be used to support. See figures 7.7 and 7.8.
- Wall shield firestops may be used to provide horizontal support.
- Ceiling firestops have tabs that may be used to provide vertical support.

**WARNING! Risk of Fire, Explosion or Asphyxiation!** Improper support could allow vent to sag and separate. Use vent run supports and connect vent sections per installation instructions. **DO NOT** allow vent to sag below connection point to appliance.

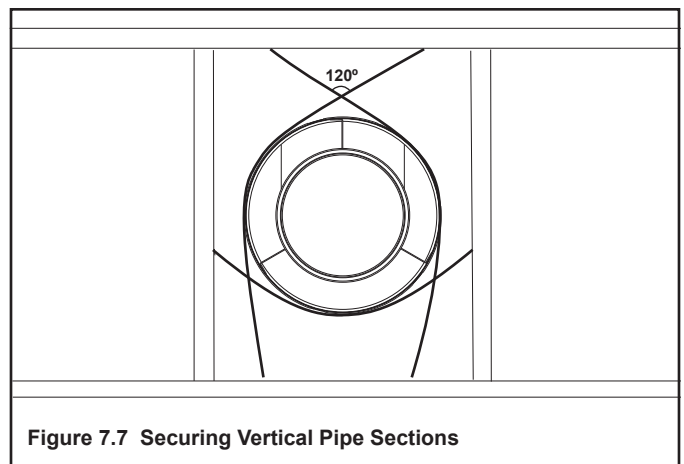

Figure 7.7 Securing Vertical Pipe Sections

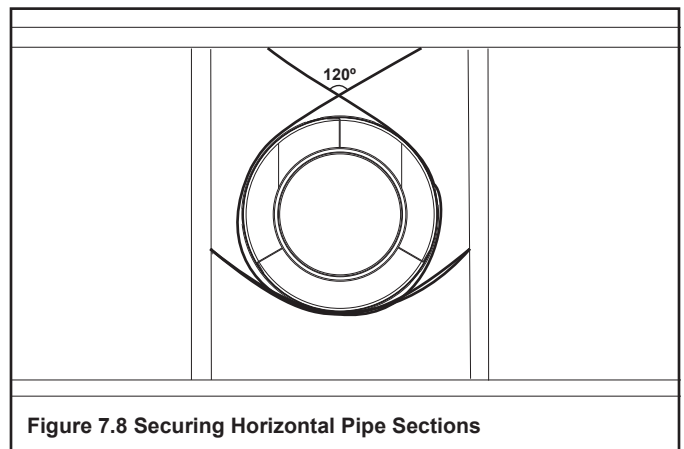

Figure 7.8 Securing Horizontal Pipe Sections

## D. Disassemble Vent Sections

- Rotate either section (see Figure 7.9) so the seams on both pipe sections are aligned as shown in Figure 7.10.
- Pull carefully to separate the pieces of pipe.

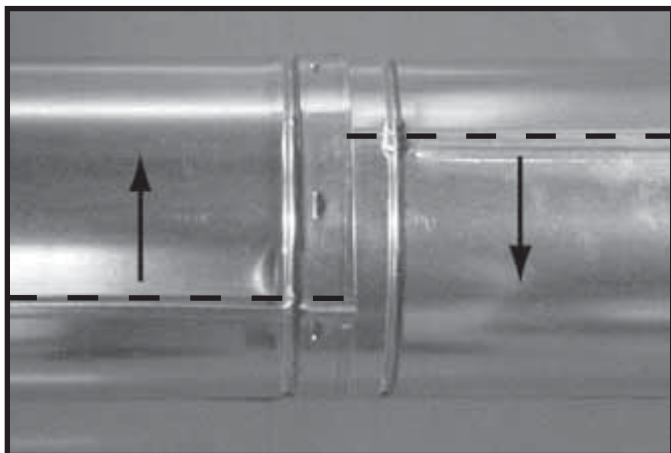

Figure 7.9 Rotate Seams for Disassembly

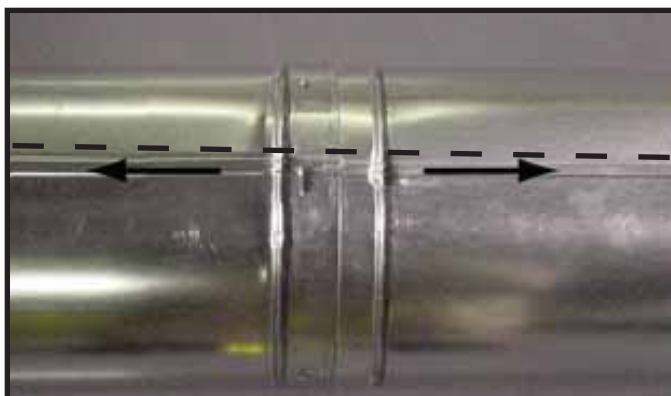
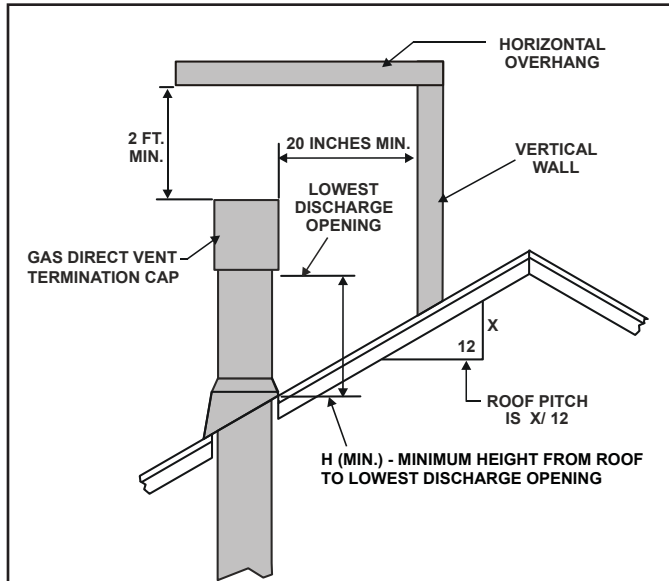

Figure 7.10 Align and Disassemble Vent Sections

## E. Vertical Termination Requirements

### Install Metal Roof Flashing

- See minimum vent heights for various pitched roofs (Figure 7.11) to determine the length of pipe to extend through the roof.
- Slide the roof flashing over the pipe sections extending through the roof as shown in Figure 7.12.



Roof Pitch	H (Min.) Ft.
Flat to 6/12	1.0*
Over 6/12 to 7/12	1.25*
Over 7/12 to 8/12	1.5*
Over 8/12 to 9/12	2.0*
Over 9/12 to 10/12	2.5*
Over 10/12 to 11/12	3.25
Over 11/12 to 12/12	4.0
Over 12/12 to 14/12	5.0
Over 14/12 to 16/12	6.0
Over 16/12 to 18/12	7.0
Over 18/12 to 20/12	7.5
Over 20/12 to 21/12	8.0

\* 3 foot minimum in snow regions

Figure 7.11 Minimum Height From Roof To Lowest Discharge Opening

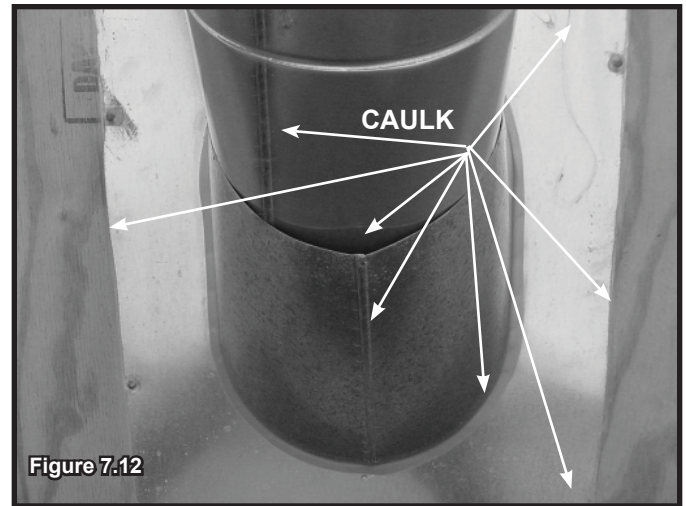

### Assemble and Install Storm Collar

**CAUTION! Risk of Cuts, Abrasions or Flying Debris.** Wear protective gloves and safety glasses during installation. Sheet metal edges are sharp.

- Slide the storm collar onto the exposed pipe section and align brackets.
- Insert a bolt (provided) through the brackets and install nut. Do not completely tighten.



- Slide the assembled storm collar down the pipe section until it rests on the roof flashing (see Figure 7.13).
- Tighten nut and make sure the collar is tight against the pipe section.
- Caulk around the top of the storm collar. See Figure 7.14.

**NOTICE:** Failure to properly caulk the roof flashing and pipe seams could permit entry of water.

- Caulk the gap between the roof flashing and the outside diameter of the pipe.
- Caulk the perimeter of the flashing where it contacts the roof surface. See Figure 7.12.
- Caulk the overlap seam of any exposed pipe sections that are located above the roof line.

## Install Vertical Termination Cap

- Attach the vertical termination cap by sliding the inner collar of the cap into the inner flue of the pipe section while placing the outer collar of the cap over the outer flue of the pipe section.
- Secure the cap by driving three self-tapping screws (supplied) through the pilot holes in the outer collar of the cap into the outer flue of the pipe (see Figure 7.14).



Figure 7.14

## F. Horizontal Termination Requirements

### Heat Shield Requirements for Horizontal Termination

**WARNING! Risk of Fire!** To prevent overheating and fire, heat shields must extend through the entire wall thickness.

- **DO NOT** remove the heat shields attached to the wall shield firestop and the horizontal termination cap (shown in Figure 7.15).
- Heat shields must overlap 1-1/2 in. (38 mm) minimum.

There are two sections of the heat shield. One section is factory-attached to the wall shield firestop. The other section is factory-attached to the cap. See Figure 7.15.

If the wall thickness does not allow the required 1-1/2 in. (38 mm) heat shield overlap when installed, an extended heat shield must be used.

- If the wall thickness is less than 4 in./102 mm, the heat shields on the cap and wall shield firestop must be trimmed. A minimum 1-1/2 in. (38 mm) overlap **MUST** be maintained.
- Use an extended heat shield if the finished wall thickness is greater than 7-1/4 in. (184 mm).
- The extended heat shield may need to be cut to length maintaining sufficient length for a 1-1/2 in. (38 mm) overlap between heat shields.
- Attach the extended heat shield to either of the existing heat shields using the screws supplied with the extended heat shield. Refer to vent components diagrams in the back of this manual.
- Rest the small leg on the extended heat shield on top of the pipe section to properly space it from the pipe section.

**Important Notice:** Heat shields may not be field constructed.



## Install Horizontal Termination Cap

**WARNING! Risk of Fire!** The telescoping flue section of the termination cap **MUST** be used when connecting vent.

- 1-1/2 (38 mm) minimum overlap of flue telescoping section is required.

Failure to maintain overlap could cause overheating and fire.

- Vent termination must not be recessed in the wall. Siding may be brought to the edge of the cap base.
- Flash and seal as appropriate for siding material at outside edges of cap.
- When installing a horizontal termination cap, follow the cap location guidelines as prescribed by current **ANSI Z223.1** and **CAN/CGA-B149** installation codes and refer to Section 6 of this manual.

**CAUTION! Risk of Burns!** Local codes may require installation of a cap shield to prevent anything or anyone from touching the hot cap.

**NOTICE:** For certain exposures which require superior resistance to wind-driven rain penetration, a flashing kit and HRC caps are available. When penetrating a brick wall, a brick extension kit is available for framing the brick.

**Note:** When using termination caps with factory-supplied heat shield attached, no additional wall shield firestop is required on the exterior side of a combustible wall.

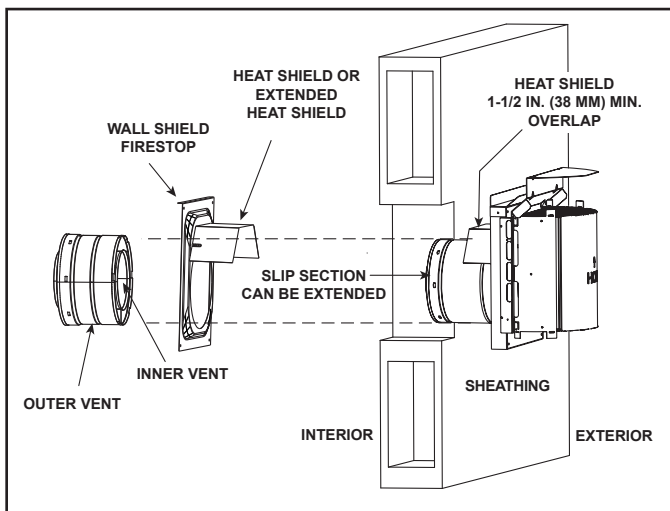

Figure 7.15 Venting Through the Wall



# 8 Electrical Information

## A. General Information

**WARNING! Risk of Shock or Explosion! DO NOT** wire 110-120 VAC to the valve or to the appliance wall switch. Incorrect wiring will damage controls.

**NOTICE:** This appliance must be electrically wired and grounded in accordance with local codes or, in the absence of local codes, with **National Electric Code ANSI/NFPA 70-latest edition or the Canadian Electric Code CSA C22.1.**

- Wire the appliance junction box to unswitched 110-120 VAC. This is required for proper operation of the appliance.
- A 110-120 VAC circuit for this product must be protected with ground-fault circuit-interrupter protection, in compliance with the applicable electrical codes, when it is installed in locations such as in bathrooms or near sinks.
- Low voltage and 110-120 VAC voltage cannot be shared within the same wall box.

## Electrical Service and Repair

**WARNING! Risk of Shock! Label all wires prior to disconnection when servicing controls. Wiring errors can cause improper and dangerous operation. Verify proper operation after servicing.**

**WARNING! Risk of Shock! Replace damaged wire with type 105° C rated wire. Wire must have high temperature insulation.**

## Junction Box Installation

**WARNING! Risk of Shock! Label all wires prior to disconnection when servicing controls. Wiring errors can cause improper and dangerous operation. Verify proper operation after servicing.**

**WARNING! Risk of Shock! Replace damaged wire with type 105° C rated wire. Wire must have high temperature insulation.**

1. Remove the one screw that secures the junction box to the control tray panel.
2. Route the wire through the strain relief in the outer wrap and down through the knockout located on top side of the junction box. See Figure 8.1.
3. Make the connection inside the junction box to the 110-120 VAC wire. Connect green to the ground nut, black to black, and white to white.
4. To reattach the junction box, insert one end of the junction box in the slot provided and securely screw the other end of the junction box to the control tray panel.

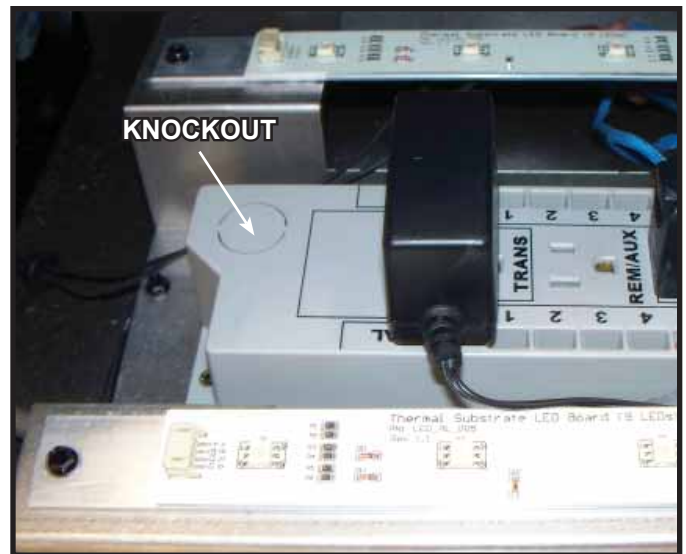

Figure 8.1 Junction Box Detail

In the event that the junction box may need to be accessed or installed after finish methods have been applied, access is possible by removing the valve assembly. See Figure 8.1.

## Accessories Requirements

- This appliance may be used with a wall switch or a wall mounted thermostat.

Wiring for optional Hearth & Home Technologies approved accessories should be done at initial installation to avoid reconstruction. Follow instructions that come with those accessories.

## B. Wiring Requirements

### IntelliFire Plus™ Ignition System Wiring

- Wire the appliance junction box to 110-120 VAC for proper operation of the appliance.

**WARNING! Risk of Shock or Explosion! DO NOT wire IPI controlled appliance junction box to a switched circuit. Incorrect wiring will override IPI safety lockout.**

- Refer to Figure 8.2, IntelliFire Plus™ Pilot Ignition (IPI) Wiring Diagram.
- This appliance is equipped with an IntelliFire Plus™ control which operates on a low voltage system.
- Plug the 6-volt AC transformer into the appliance junction box to supply power to the appliance.

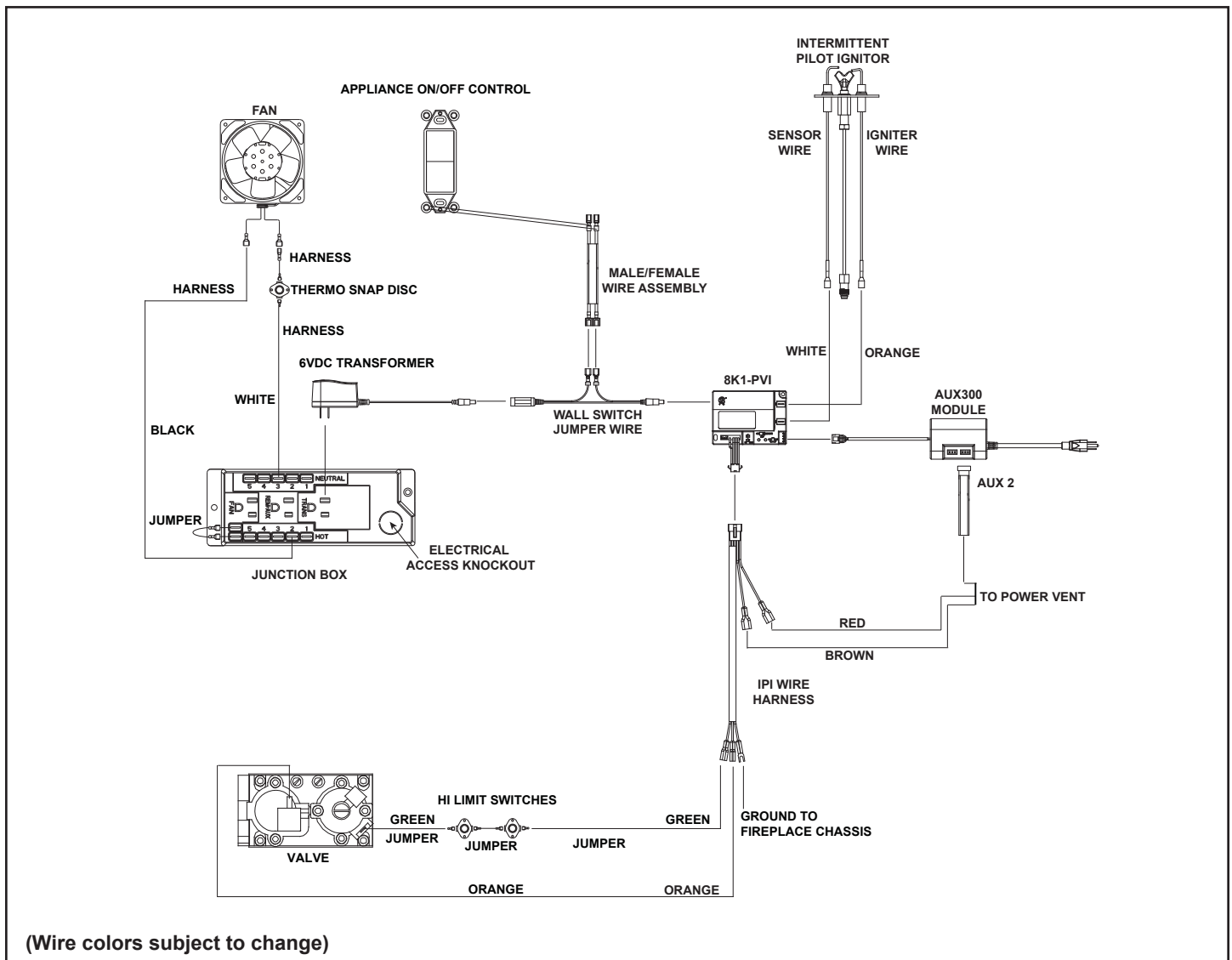

Figure 8.2 RED60 IntelliFire Plus Wiring Diagram

## Optional Configuration Requirements

- This appliance ships standard with a wall switch.

Wiring for optional Hearth & Home Technologies approved accessories should be done now to avoid reconstruction. Follow instructions that come with those accessories.

The junction box, control module, power vent power supply and LED power supply can be accessed thru the air space between the firebox front and the lower-front finishing cover panel. The decorative front and glass assembly must be removed to access these components. See Figure 8.3.

The heat shield cover must also be removed to gain access to the control module. Replace heat shield cover after accessing module in order to protect components from overheating and possible damage, such as melting.

**WARNING! Risk of Shock! Replace heat shield cover. Exposed components may overheat and be damaged or ruined.**

**Note:** If the fan is moved from one side to the other, the valve, all electrical components, including the thermodiscs, must also be moved to the opposite side of the appliance. See appropriate configuration in relation to the valve in Figures 8.4 and 8.5. In addition, two jumper wires will be required between the two 107-559a wire harnesses that plug into the junction box. These wires must be 24 inches in length, made from 14 gauge AWG wire (or equivalent), have a 1/4 inch male insulated terminal at each end and be made by a licensed electrician following all local electrical codes.

A battery back up is not compatible with the RED60 and may not be installed.

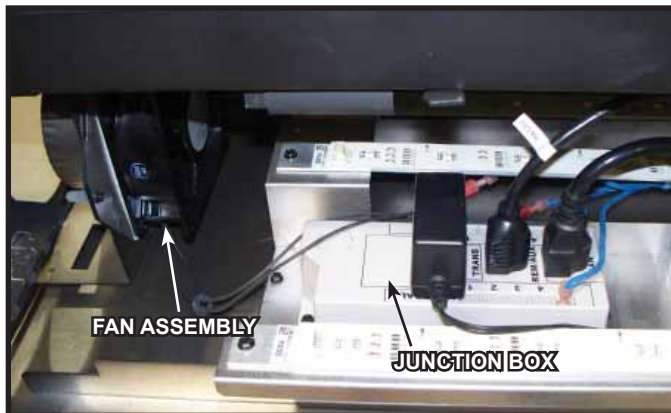

Figure 8.3 Valve Cavity (Lower Access Panel Removed)

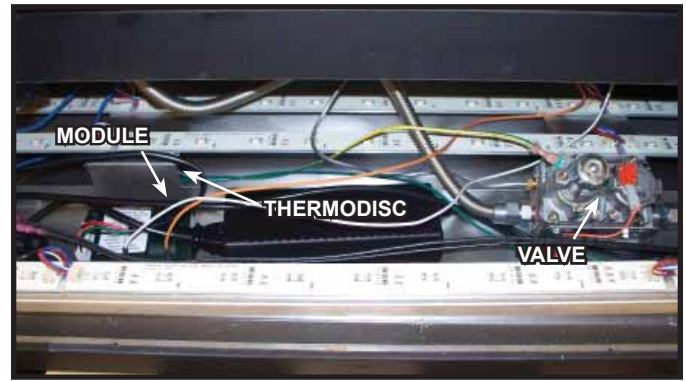

Figure 8.4 Valve Cavity

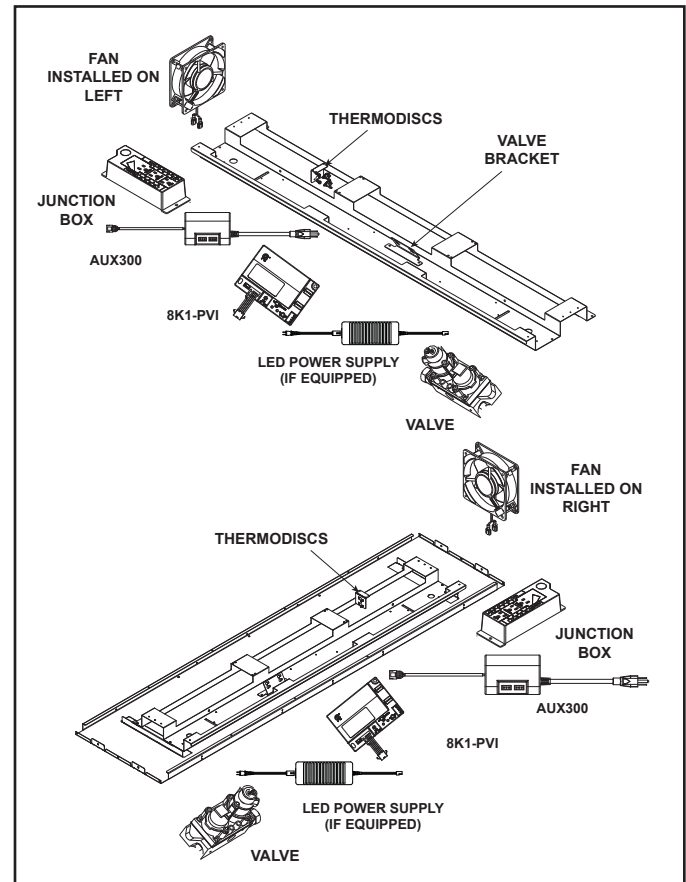

Figure 8.5 Controls Location Diagram

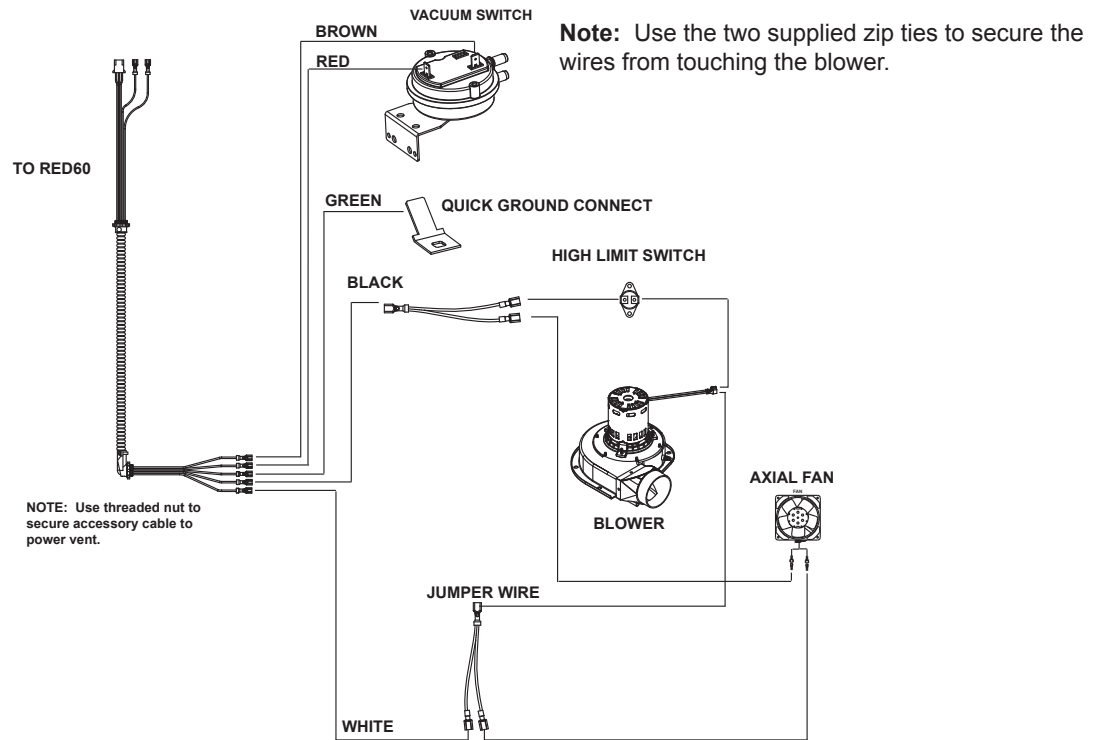

Figure 8.6 Internal Wiring for PVI-DVP

## C. Optional LED Lighting Circuit

For models with LED lighting option only.

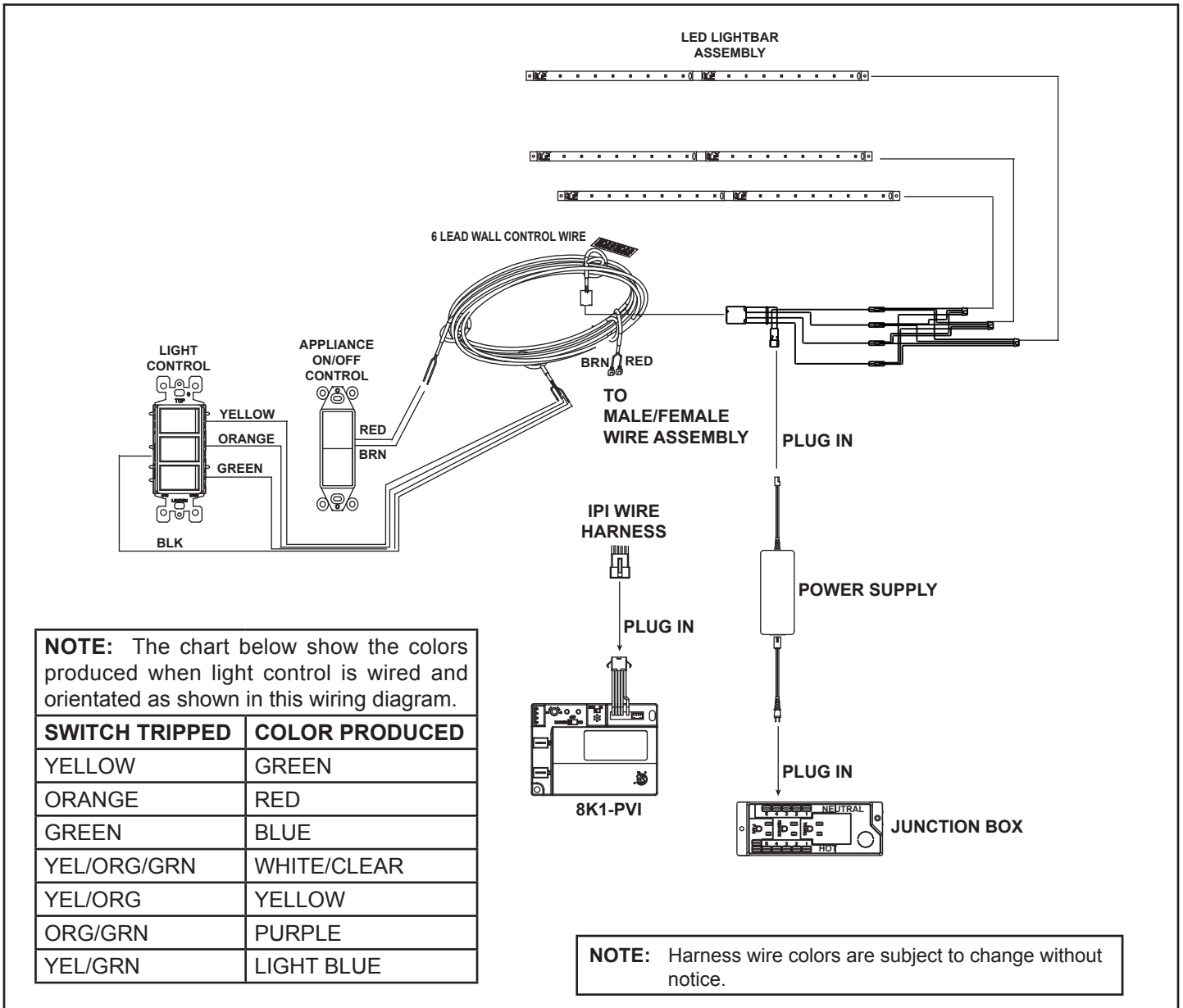

Figure 8.7 LED Wiring Diagram



## D. Active Convection Blower Replacement

**WARNING! Risk of Shock!** Label all wires prior to disconnection when servicing controls. Wiring errors can cause improper and dangerous operation. Verify proper operation after servicing.

**WARNING! Risk of Shock!** Replace damaged wire with type 105° C rated wire. Wire must have high temperature insulation.

1. Remove any interior enhancement kit(s), such as glass rock media, granite or porcelain, that have been already installed in the appliance.
2. Remove pilot shield as shown in Figure 8.8.



Figure 8.8 Removing Pilot Shield

3. Remove screws from base pan and lift base pan up and out of appliance. Set aside. See Figure 8.9 and Figure 8.10.



Figure 8.9 Removing Screws from Base Pan



Figure 8.10 Lifting Base Pan Up and Out.

4. Remove screws from each end of burner assembly. Pull burner out of appliance. Set aside.

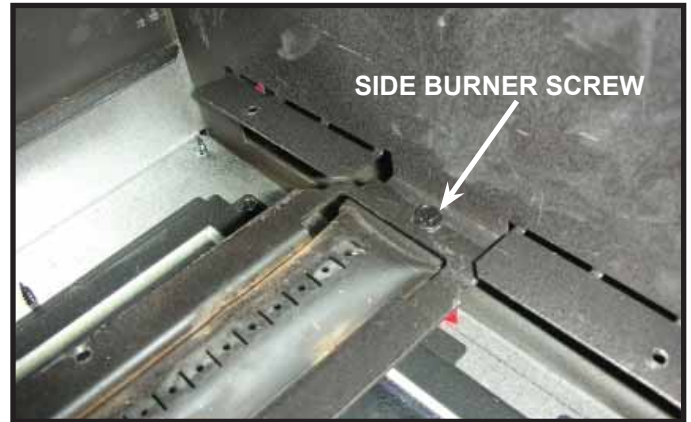

Figure 8.11 Side Burner Screw

5. Remove left or right side glass pane frame, depending on placement of blower, from bottom of firebox. Remove glass pane and gaskets. Gaskets may have become fragile from heat exposure. Handle with care. At this point, blower and other components located under the firebox are accessible.



Figure 8.12 Glass Pane Frame



Figure 8.13 Removing Glass Pane Frame

6. Remove four screws from valve and component tray that is attached to the very bottom of the fireplace. This entire tray can be slid to the side to provide easier access to the blower. Removing these screws will require a longer bit shaft in a cordless drill to reach down through the firebox opening. See Figure 8.14.



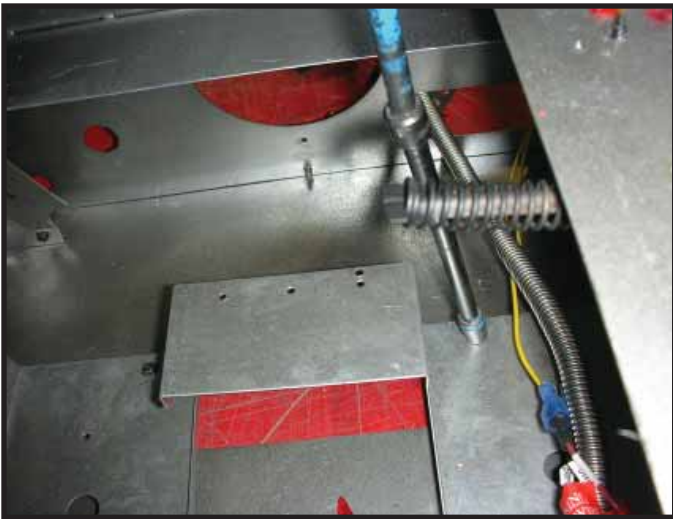

Figure 8.14 Component Tray



Figure 8.15 Blower Mounting Bracket

7. Unplug blower power wires. Pull blower mounting bracket toward you and remove hose clamp and air duct. Remove blower and attached mounting bracket from the appliance. See Figure 8.16.



Figure 8.16 Blower Removal Through Hole in Firebox

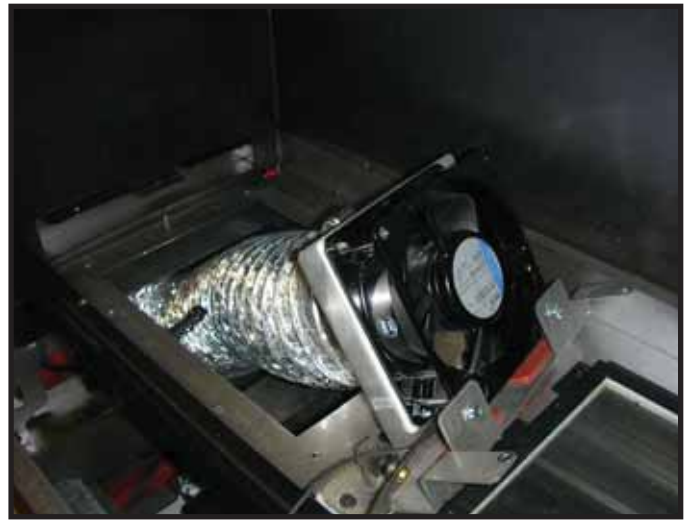

Figure 8.17 Fan Removal Through Firebox Bottom

8. Remove mounting bracket from blower by removing the four screws that hold the blower to the bracket. They are located on one side of the bracket. Save the gasket for use with the new blower. See Figure 8.18 and Figure 8.19.

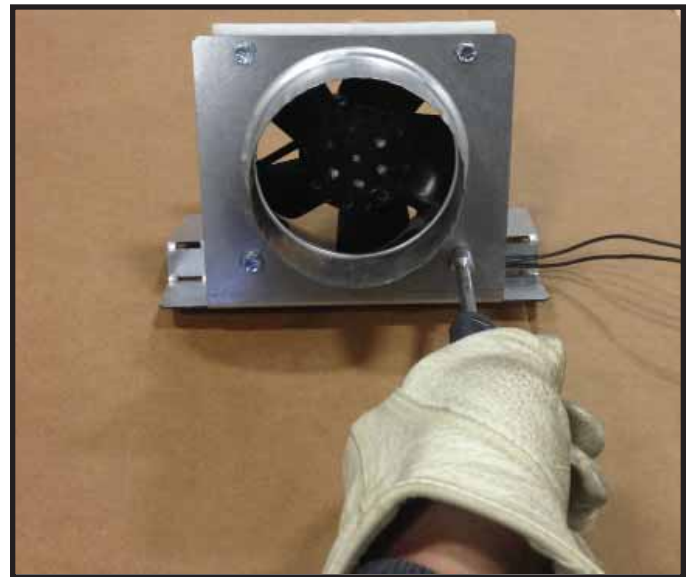

Figure 8.18 Removal of Mounting Bracket from Blower

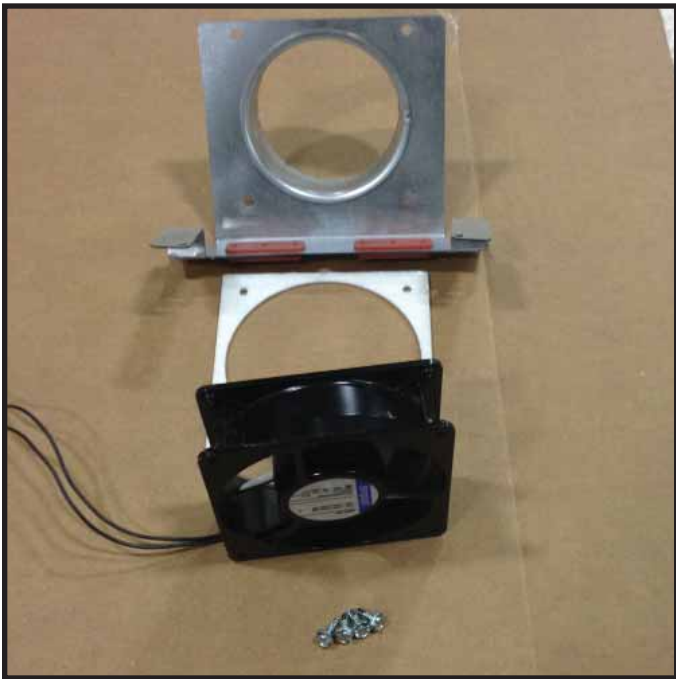

Figure 8.19 Blower, Gasket Mounting Bracket, and Hardware

9. Position the fan so that the arrow on the side of the fan points toward the interior of the appliance. Arrows are highlighted by white boxes in Figure 8.20.



Figure 8.20. Arrow Indicates Direction of Air Flow

10. Attach new blower to mounting bracket by fastening the four screws in the appropriate locations. See Figure 8.21.



Figure 8.21. Proper Blower Mounting.

11. Connect electrical cord to the junction box.

# 9 Gas Information

## A. Fuel Conversion

- Make sure the appliance is compatible with available gas types.
- Conversions must be made by a qualified service technician using Hearth & Home Technologies specified and approved parts.

## B. Gas Pressure

- Optimum appliance performance requires proper input pressures.
- Gas line sizing requirements will be determined in ANSI Z223.1 National Fuel Gas Code in the USA and CAN/CGA B149 in Canada.
- Pressure requirements are:

Gas Pressure	Natural Gas	Propane
Minimum inlet pressure	5.0 in. w.c.	11.0 in. w.c.
Maximum inlet pressure	10.0 in. w.c.	13.0 in. w.c.
Manifold pressure	3.5 in. w.c.	10.0 in. w.c.

**WARNING! Risk of Fire or Explosion! High pressure will damage valve. Low pressure could cause explosion.**

- Verify inlet pressures. Verify minimum pressures when other household gas appliances are operating.
- Install regulator upstream of valve if line pressure is greater than 1/2 psig.
- Valve pressure taps are accessible by removing the outer panel tray and glass assembly.



Figure 9.1. Valve Pressure Taps.

**⚠ WARNING**

Fire Risk.  
Explosion Hazard.  
High pressure will damage valve.

- Disconnect gas supply piping BEFORE pressure testing gas line at test pressures above 1/2 psig.
- Close the manual shutoff valve BEFORE pressure testing gas line at test pressures equal to or less than 1/2 psig.

**Note:** Have the gas supply line installed in accordance with local codes, if any. If not, follow ANSI 223.1. Installation should be done by a qualified installer approved and/or licensed as required by the locality. (In the Commonwealth of Massachusetts installation must be performed by a licensed plumber or gas fitter).

**Note:** A listed (and Commonwealth of Massachusetts approved) 1/2 in. (13 mm) T-handle manual shut-off valve and flexible gas connector are connected to the 1/2 in. (13 mm) control valve inlet.

- **If substituting for these components, please consult local codes for compliance.**

**Note:** This appliance does include a manual gas shutoff valve that is located in the valve compartment. This manual gas shutoff valve is accessible for service by removing the outer access panel tray or the base pan and burner assembly and inner access windows. Depending upon local code, an additional manual gas shutoff, in a readily accessible area may be required and located upstream from the appliance.

The lower access cover panel is removable if finishing material is not installed. See Figure 9.2.

If the finishing materials have been installed around the appliance opening, proceed as follows:

1. If already installed, carefully remove the front media and tray or granite or porcelain from the appliance and set aside.
2. Unplug the 6V transformer from the junction box. This will turn the power off to the appliance.
3. Turn the gas shutoff handle to the "OFF" position to shut off the gas supply.
4. Remove the glass assembly from the appliance by unlatching the four bottom spring latches and then pulling the bottom of the glass assembly toward you until it clears the glass latch tabs. Hold the top of the glass frame and gently lower the glass assembly down until it rests on the side glass supports. Tilt the top of the glass out toward you and remove. See Section 11.A.
5. Remove any interior media, granite or porcelain from the unit if already installed.
6. There are three access windows located on the interior of the firebox bottom. See Figure 9.2. Remove screws and plate to access the manual shutoff valve included with this fireplace.

To access unit through the lower bottom windows:

1. Remove the glass rock media or the porcelain from the interior firebox.



- Remove the base pan. It is attached with 14 screws to the interior firebox bottom and with 19 screws to the burner assembly. If your appliance is a model that has the glass rock media, you must also remove the pilot shield cover at this time. See Figure 9.2 and Figure 9.3.
- Remove the two screws that secure the pilot to the burner tube. Remove the two screws that secure the burner to the firebox sides and disengage burner from over orifice. Remove burner. See Figure 9.3.
- Remove access panel covers or glass windows, along with gaskets. Gaskets may be fragile. Handle with care. See Figure 9.2.

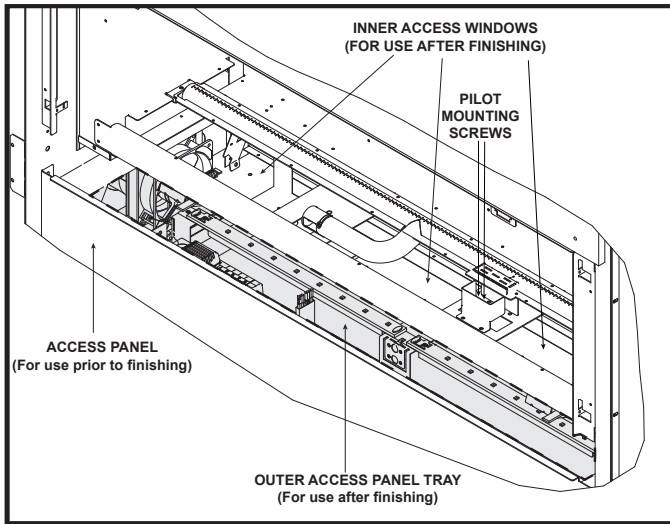

Figure 9.2 Gas and Electrical Access

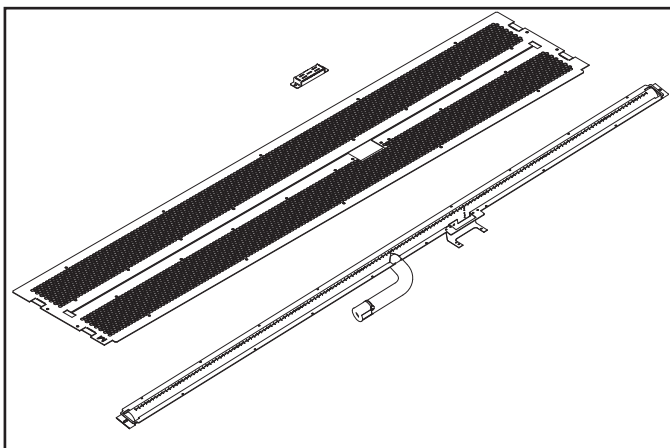

Figure 9.3. Base Pan with Burner and Pilot Cover

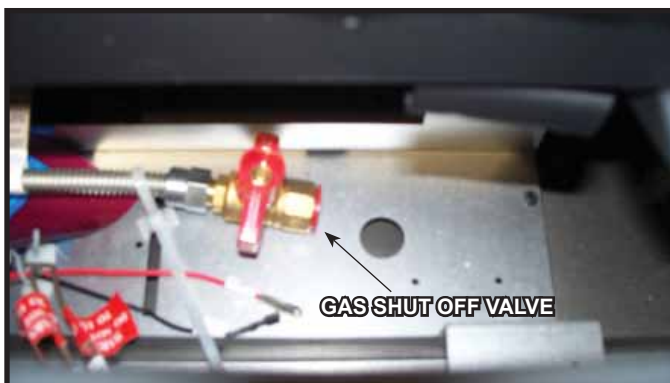

Figure 9.4 Gas Fitting Access

## C. Gas Connection

- Refer to Section 3 for location of gas line access in appliance.
- Gas line may be run through either side of appliance.
- The gap between supply piping and gas access hole may be caulked with caulk with a minimum of 300°F continuous exposure rating or stuffed with non-combustible, unfaced insulation to prevent cold air infiltration.
- Ensure that gas line does not come in contact with outer wrap of the appliance. Follow local codes.
- Pipe incoming gas line into valve compartment.
- Connect incoming gas line to the 1/2 in. (13 mm) connection on manual shutoff valve.

**WARNING! Risk of Fire or Explosion!** Support control when attaching pipe to prevent bending gas line.

- A small amount of air will be in the gas supply lines.

**WARNING! Risk of Fire or Explosion!** Gas build-up during line purge could ignite.

- Purge should be performed by qualified service technician.
- Ensure adequate ventilation.
- Ensure there are no ignition sources such as sparks or open flames.

Light the appliance. It will take a short time for air to purge from lines. When purging is complete the appliance will light and operate normally.

**WARNING! Risk of Fire, Explosion or Asphyxiation!** Check all fittings and connections with a non-corrosive commercially available leak-check solution. **DO NOT** use open flame. Fittings and connections could have loosened during shipping and handling.

**WARNING! Risk of Fire! DO NOT** change valve settings. This valve has been preset at the factory.

## D. High Altitude Installations

**NOTICE:** If the heating value of the gas has been reduced, these rules do not apply. Check with your local gas utility or authorities having jurisdiction.

When installing above 2000 feet elevation:

- In the USA: Reduce burner orifice 4% for each 1000 feet above 2000 feet.
- In CANADA: Reduce burner orifice 10% for elevations between 2000 feet and 4500 feet. Above 4500 feet, consult local gas utility.

## E. Air Shutter Setting

Air shutter settings may be adjusted by a qualified installer at the time of installation. The air shutter is set at the factory for minimum vertical vent run. Adjust air shutter for longer vertical runs. See Figure 9.5.

- Loosen the 1/4 in. screw.
- Twist shutter to adjust.
- Shutter may be open for longer horizontal vent runs.
- Do not close the air shutter more than 1/16 in. for NG or 1/4 in. for propane.
- Tighten the screw.

**NOTICE:** If sooting occurs, provide more air by opening the air shutter.

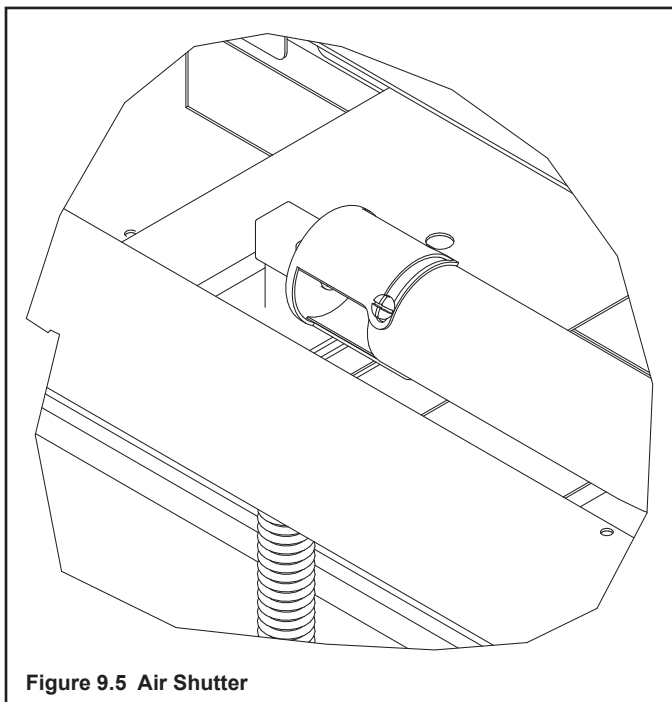

Figure 9.5 Air Shutter

### Air Shutter Settings

RED60	NG	PROPANE
LIGHT & MEDIA KIT	.06 in.	1/4 in.
FULL PORCELAIN KIT	.16 in.	1/4 in.
SHEET METAL REFRACTORY	.16 in.	1/4 in.

# 10 Finishing

## A. Facing and Finishing Instructions

**WARNING! Risk of Fire! DO NOT** apply combustible materials beyond the minimum clearances. Comply with all minimum clearances to combustibles as specified in this manual. Overlapping materials could ignite and will interfere with proper operation of doors and louvers.

The splatter guard is a piece of corrugated material used to protect the appliance during the installation process before finishing work on the whole hearth is complete. A splatter guard is factory installed on RED60 models. Splatter guards must be removed before appliance is fired.

**WARNING! Risk of Fire! Remove the splatter guard before lighting the appliance. Shut off gas to the appliance when the splatter guard is in place to prevent accidental operation.**

### Finishing Instructions

**WARNING! Risk of Fire! Comply with all minimum clearances to combustibles as specified. Framing closer than the minimums listed must be constructed entirely of non-combustible materials (i.e., steel studs, concrete board, etc.).**

It is important to follow the framing and finishing instructions to ensure proper placement of fireplace into the surrounding framing/finishing materials.

Wall sheathing materials 1/2 in. thick are specified in this installation manual to properly align with the factory-installed non-combustible material.

**WARNING! Risk of Fire! DO NOT remove the factory-installed non-combustible board or cover it with combustible material, such as:**

- Drywall (gypsum board)
- Plywood
- Materials that do not meet the ASTM E 136 Non-combustibility standard (below).

*Removal of factory-installed, non-combustible board and/or use of materials not meeting the ASTM E 136 standard may cause fire.*

### Non-Combustible Materials Specification

Material which will not ignite and burn. Such materials are those consisting entirely of steel, iron, brick, tile, concrete, slate, glass or plasters, or any combination thereof.

Materials that are reported as passing **ASTM E 136, Standard Test Method for Behavior of Materials in a Vertical Tube Furnace at 750 °C** shall be considered non-combustible materials.

**WARNING! Risk of Fire! Maintain specified air space clearances to combustibles. Inadequate air space could cause overheating and fire.**

Ensure that the one inch back clearance and one inch side clearances are maintained.

**WARNING! Risk of Fire! DO NOT use screws longer than two inches when attaching finishing materials to non-combustible material. Screws longer than two inches will compromise clearance and could cause overheating and fire.**

**CAUTION! Risk of Glass Damage and Cuts! DO NOT drill or install any type of screw or fastener into the lower cover panel. Sharp screw or fastener tips could penetrate and break the glass or cause cuts.**

The RED60 comes standard with a mesh front. The final fireplace installation can be accomplished by either the “overlap” or “inside-fit” method. Installation details associated with the Inside and Overlap Fit methods are discussed in this section.

If the final fireplace installation uses the Overlap Method, wall sheathing material 1/2 in thick is specified and can be installed tight to the side finishing flanges and factory-supplied non-combustible board. If the final fireplace installation uses the Inside-Fit Method, additional clearance must be maintained between combustible 1/2 in. thick wall sheathing material and the side finishing flanges. Installation details associated with the Inside and Overlap Fit methods and specified additional non-combustible materials required are discussed in this section.

When finishing the wall around the fireplace, it is critical that wall sheathing be fastened properly. Wall sheathing fasteners, such as screws or nails, are not permitted in some locations. It is acceptable to pre-drill holes and use self-tapped screws in the factory-installed non-combustible board which may be used to lathe (a backer for tile, marble, etc.) Screws being installed through the factory-installed non-combustible board should be self-tapping type with a maximum length of 2 inches. See Figure 10.1. Do not drill or install screws which may penetrate the lower cover panel as this will restrict required access to the glass and lower control chamber.

The appliance is designed to mate with 1/2 in. wall sheathing materials such as drywall, plywood, wood composites, or non-combustible materials. The type of material used depends whether the installation is an Inside or Overlap Fit method. Installation details associated with the Inside and Overlap Fit methods are discussed in this section.



Verify that the lower cover panel is installed correctly, and that there are no screws used to attach drywall to the panel.

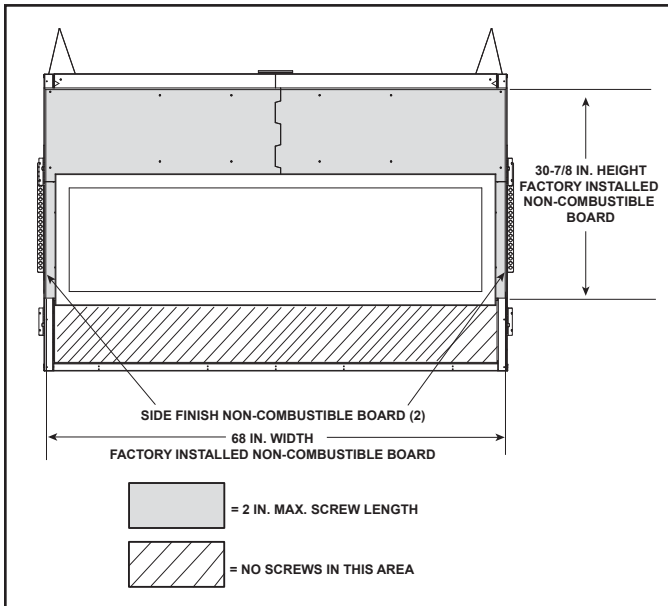

Figure 10.1 Finishing Details

**Note:** It is acceptable to use a high temperature silicone sealant to adhere drywall to lower cover panel.

### Finish and Sealing Joints

All joints between the finished wall sheathing and the appliance must be sealed with non-combustible materials. Sealants, such as caulk or mastic used to seal the gap between the wall and the fireplace, should be rated at a minimum continuous exposure to 300°F.

### Finishing Around Opening with Gypsum Wallboard

Gypsum wallboard (drywall) joints adjacent to the fireplace opening, including the non-combustible board on the appliance, require special attention to minimize cracking. When installing gypsum wallboard around the fireplace, install the hole for the fireplace opening in a single wallboard sheet, if possible. This will minimize the joints adjacent to the fireplace opening.

Tape wall board joints around the fireplace opening with fiberglass-mesh tape. It will provide a more crack-resistant joint than paper tape. Fill, smooth and finish wall joints with chemically setting-type joint compound. It will provide a more crack-resistant joint than air-drying light-weight compound.

### Painting

If desired finishing includes a painted wall, 100% acrylic latex with compatible primer is recommended around this appliance. Oil-based or standard acrylic paints may discolor due to heat exposure.

### Facing Material

- Facing and/or finishing materials must not interfere with air flow through louvers, operation of louvers or doors, or access for service.
- Facing and/or finishing materials must never overhang into the glass opening.
- Observe all clearances when applying combustible materials.

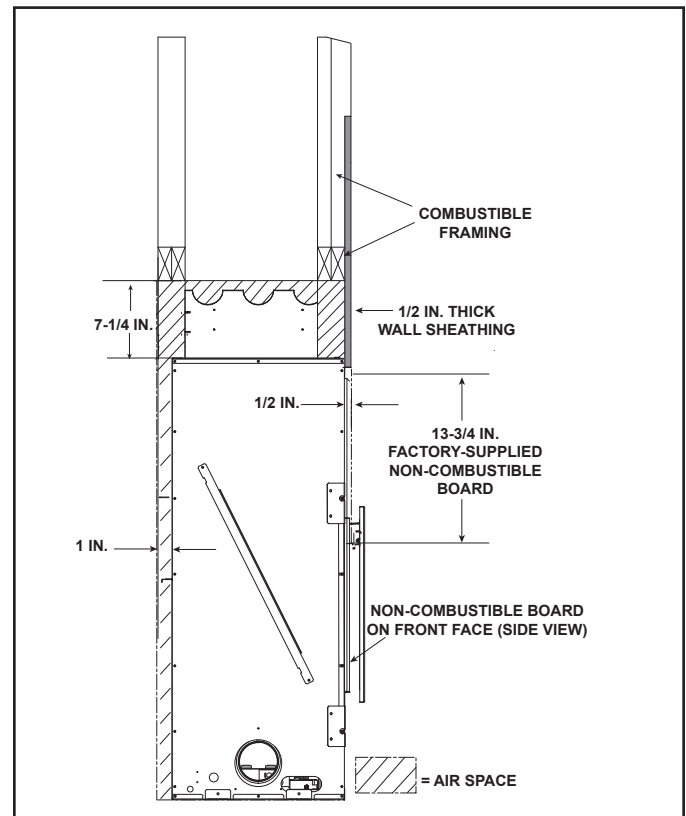

Figure 10.2 Framing and Framing Materials-RED60

**WARNING! Risk of Fire! DO NOT** apply combustible materials beyond the minimum clearances. Comply with all minimum clearances to combustibles as specified in this manual. Overlapping materials could ignite and will interfere with proper operation of doors and louvers.

**WARNING! Risk of Fire! DO NOT** install drywall or other combustible materials directly onto the factory-installed non-combustible board. Overlapping materials could ignite.

Decorative facing material thickness is measured from the face of the factory-installed non-combustible board. See Figure 10.2.

The mesh front can be installed such that it overlaps non-combustible materials up to 1-1/4 in. thick. See Figure 10.3. Refer to Section 1.E and 1.F of this manual for definition and qualifications and definition of non-combustible and combustible materials.

Specific requirements for each method if installation are described on the following pages of this section.

## Non-Combustible Finish Materials

### 0 to 1-1/4 inch thickness-Overlap Fit Method

The mesh front is designed to overlap finish materials 0 inches to 1-1/4 inch thick. See Figure 10.4.

**NOTICE:** This 1-1/4 inch maximum not only includes the decorative finish materials (marble, tile, slate, etc) but also the thin set, lath and adhesive used to attach the decorative finish material.

The non-combustible finish material can be installed up to the 17-1/8 inch (height) by 62-3/4 inch (width) fireplace opening.

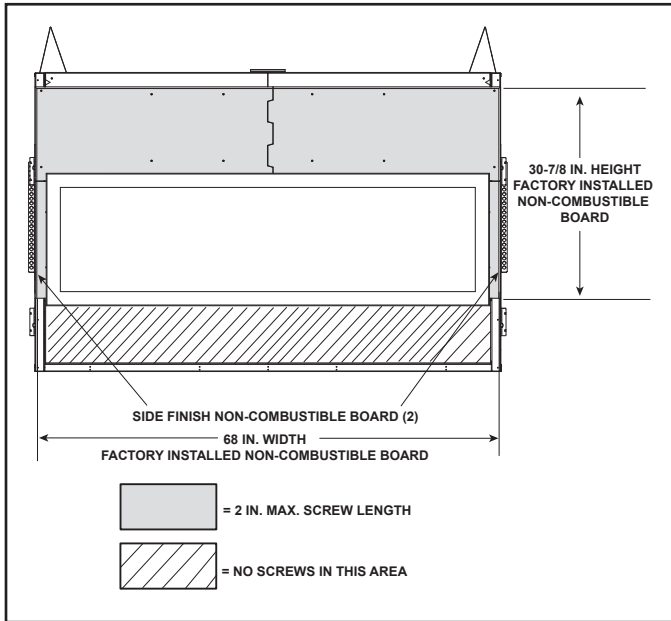

Figure 10.3 Non-Combustible Finish Material Diagram for 0 - 1-1/4 Inch Thick Overlap Fit Method

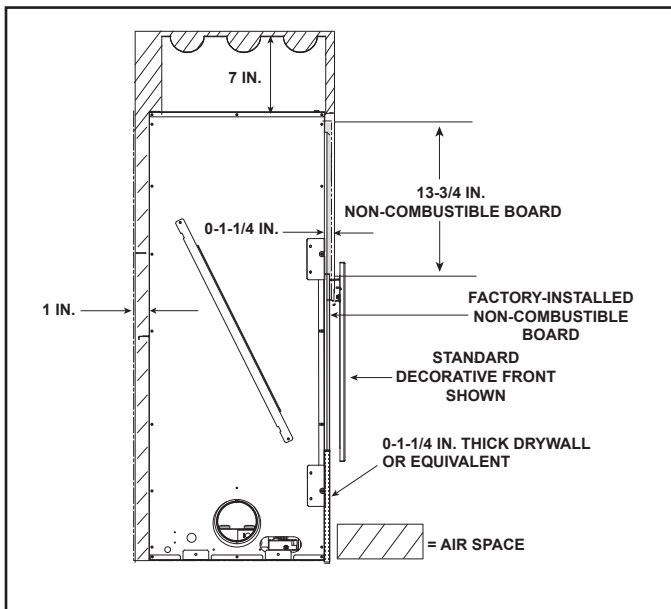

Figure 10.4 Overlap Fit Method

## Non-Combustible Finish Materials

### 0 Inches to 4 Inches Thick-Inside Fit Method

The mesh decorative front is approved for inside fit applications. Non-combustible finishing materials up to 4 inches thick can be installed around the Mesh front (left, right, top, and bottom). See Figure 10.5.

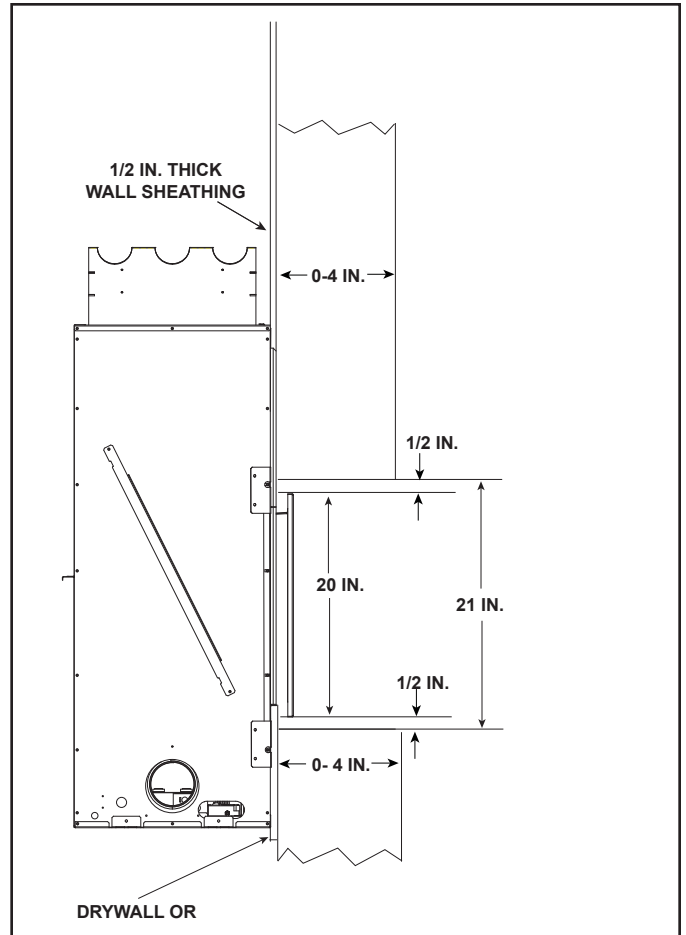

Figure 10.5 Inside Fit Method

Ensure that no non-combustible finish materials are installed within 1-11/16 inches of top and bottom and 1-3/8 inches from right and left sides of fireplace opening. This will ensure adequate clearance for required mesh front. See Figure 10.9.

Refer to Section 1.E and 1.F of this manual for definition and qualifications and definition of non-combustible and combustible materials.

## B. Mantel and Wall Projections

**WARNING! Risk of Fire!** Comply with all minimum clearances to combustibles as specified. Framing closer than the minimums listed must be constructed entirely of noncombustible materials (i.e., steel studs, concrete board, etc.)

**Note:** For non-combustible fireplace finish material (marble, stone, etc) specifications refer to Section 10.A.

### Combustible Mantels

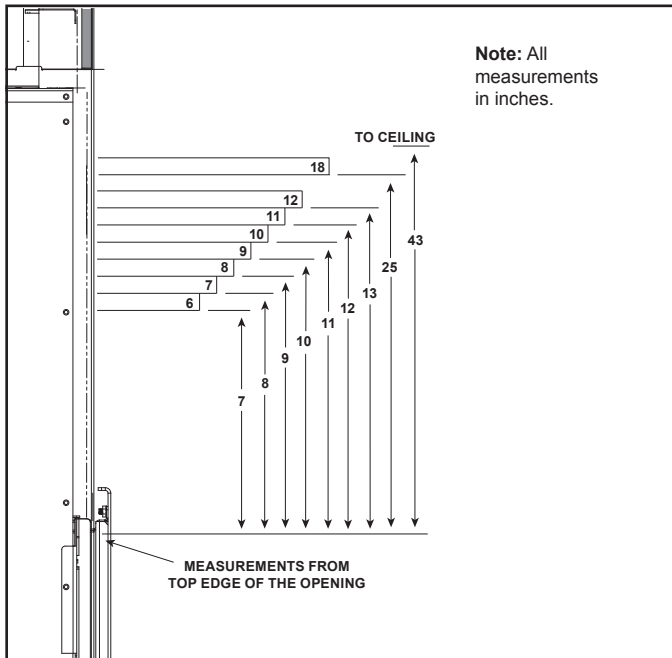

Figure 10.6 Minimum Vertical and Maximum Horizontal Dimensions of Combustibles

**Note:** For non-combustible fireplace finish material (marble, stone, etc) specifications refer to Section 10.A.

### Non-Combustible Mantels

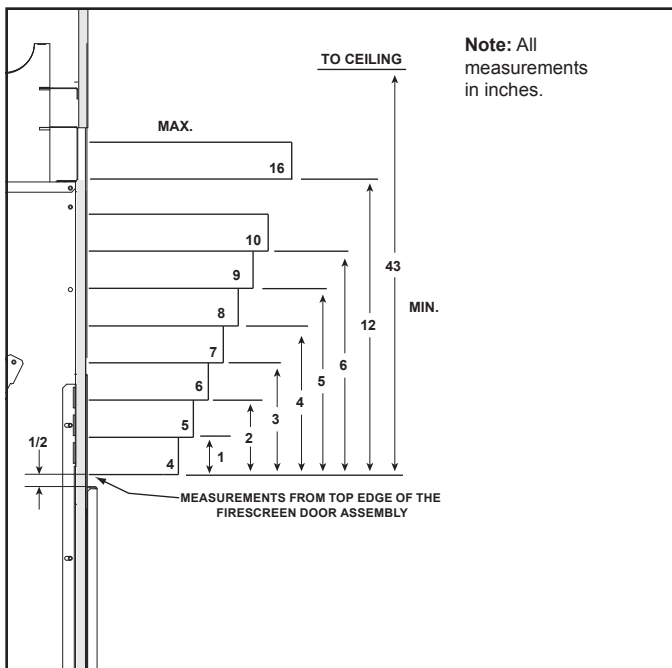
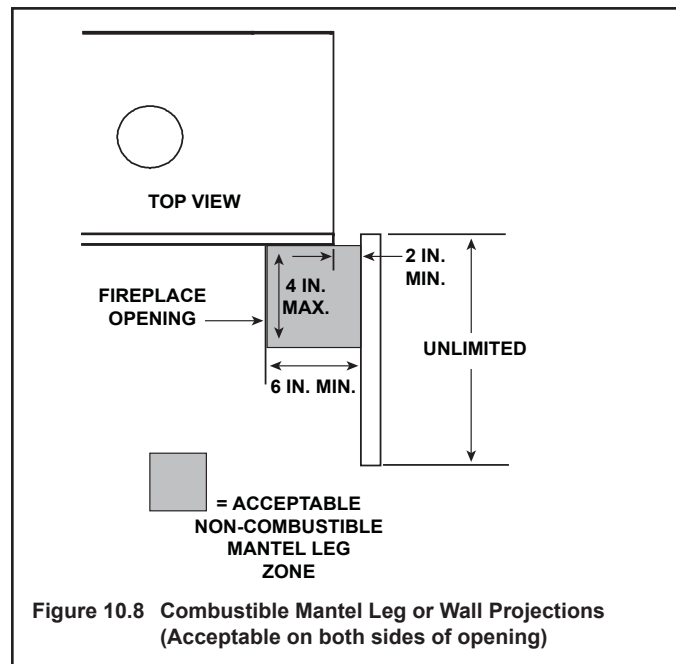

Figure 10.7 Minimum Vertical and Maximum Horizontal Dimensions of Non-Combustibles

## Mantel Legs Or Wall Projections Extending Past The Face Of The Fireplace



## C. Mesh Fronts

**WARNING! Risk of Burns!** A decorative front is required for this model. DO NOT operate this appliance without a decorative front in place.

A mesh front is included with the RED60. This is the door approved with this appliance model. It must be used.

To attach the mesh front to the appliance, use the two mesh brackets. These brackets are mounted to the underside of the top of the appliance viewing area and are fastened to the appliance by two screws on each bracket. See Figure 10.10. There are two hanging tabs on the back of the mesh front assembly that are bent upward. Engage these tabs in the slot of the brackets.

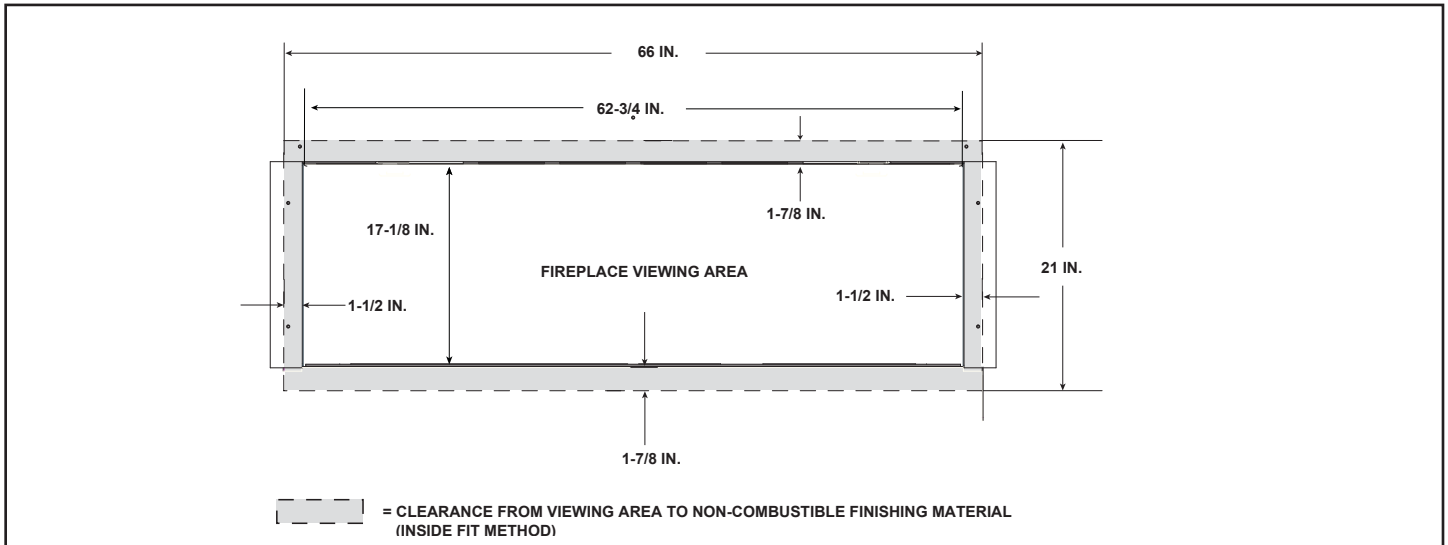

Figure 10.9 Non-Combustible Surface Finishing Material 0-4 Inches Thick-Inside Fit Method

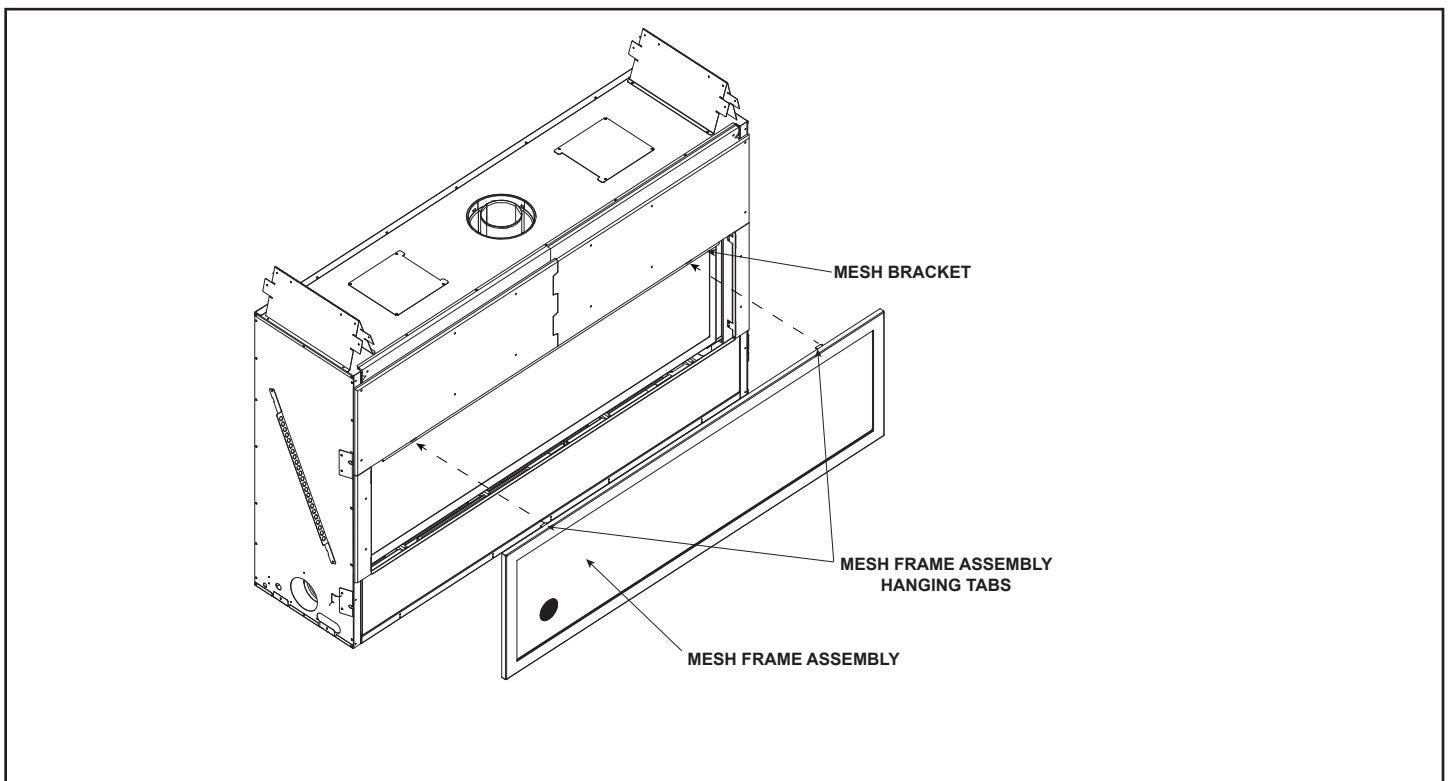

Figure 10.10 Mesh Front Installation

# 11 Appliance Setup

## A. Fixed Glass Assembly

**WARNING! Risk of Asphyxiation!** Handle fixed glass assembly with care. Inspect the gasket to ensure it is undamaged and inspect the glass for cracks, chips or scratches.

- **DO NOT** strike, slam or scratch glass.
- **DO NOT** operate fireplace with glass removed, cracked, broken or scratched.
- Replace as a complete assembly.

### Removing Fixed Glass Assembly

1. Remove the decorative front.
2. Locate the four spring latches that are on the lower left and right of the fireplace.
3. Use both index fingers to release spring latches. See Figure 11.1.
4. Allow glass to tilt forward. Grasp glass on the upper return lip of glass frame and tilt glass “out” and “down”. Lower gently to rest on side supports. See Figure 11.1. Allow top of glass assembly to tilt forward. Lift glass assembly “up” and “out”.

### Replacing Fixed Glass Assembly

1. Locate glide tabs on lower left and right corners.
2. Place glass bottom resting on right and left support. Tilt top of glass assembly toward fireplace.
3. Allow of the gasketing of the glass assembly to touch the face of the fireplace. Lift the glass “up” and “in” to upper glass clip flanges.
4. Hold bottom of the glass as you allow the glass assembly to seat over the four lower glass clips. See Figure 11.1.
5. Assure proper left and right placement of glass and engage all lower spring latches.

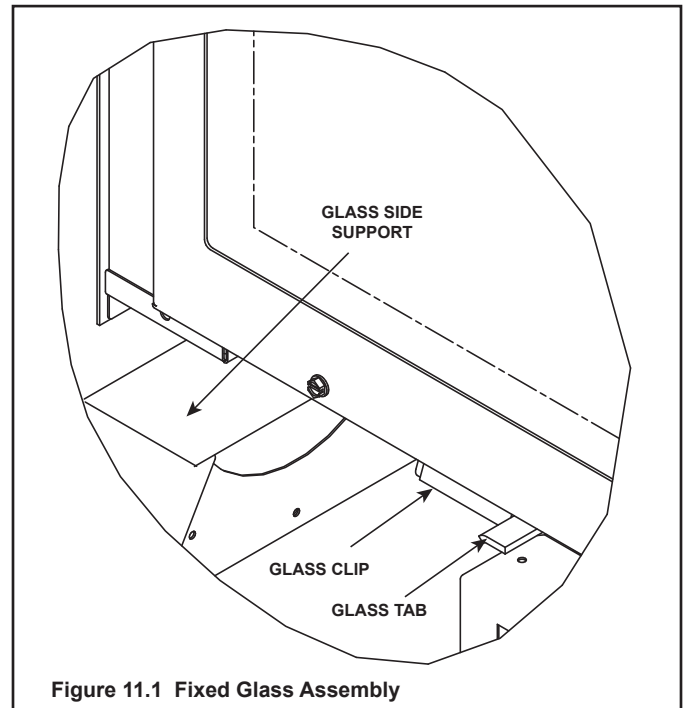

Figure 11.1 Fixed Glass Assembly

## B. Remove the Shipping Materials

Remove shipping materials from inside or underneath the firebox. Verify all components are with the fireplace.

## C. Clean the Appliance

Clean/vacuum any sawdust that may have accumulated inside the firebox or underneath in the control cavity.

## D. Accessories

Install approved accessories per instructions included with accessories. Contact your dealer for a list of approved accessories.

**WARNING! Risk of Fire and Electric Shock!** Use ONLY Hearth & Home Technologies-approved optional accessories with this appliance. Using non-listed accessories could result in a safety hazard and will void the warranty.

## E. Rock Media Instructions

A Rock Media Kit is available for use with the RED60 model. Install Rock Media according to these instructions

**WARNING! Choking Hazard!** Keep rock media out of reach of children.

**CAUTION! Risk of Cuts, Abrasions or Flying Debris.** Wear protective gloves and safety glasses during installation. Sheet metal edges are sharp.

### Preparation

**CAUTION! Risk of Burns!** The fireplace should be turned off and cooled before rock media is installed.

1. Remove glass assembly. See Section 11.A for instructions.
2. Remove any refractory, side panels or media currently installed in appliance. After removing these items, the base pan will be visible on the inside of the appliance.
3. Verify that the correct basepan is installed inside the appliance. See Figure 2.

**NOTICE:** The installation of the rock media kit may require the air shutter setting to be changed. See Section 9.E of this manual to ensure the shutter gap is set correctly before firing the appliance.

**Note:** Optional Porcelain or Granite Kits used with lighted and plain media units must be placed in unit before placing glass media in the unit.

### Cleaning the Rock

During shipment of the rock media, dust and debris can accumulate. It is recommended that the rock media be rinsed thoroughly with water to remove dust and small glass particles. An easy method to clean the rock media is to place the rock media into a pail and rinse thoroughly. Spread the media out over paper towels and allow the rock media to dry before installing into the fireplace.

### INSTALLATION

1. Choose 7 - 10 flat, quarter-sized, pieces of rock media and set aside. These will be used later to conceal the pilot cover. Reference Figure 1 for choosing flat pieces of glass.
2. The included rock media placement jig **MUST** be used any time rock media is placed on the burner to ensure that no rock media pieces end up in the burner lighting area. Verify that the rock media placement jig is correctly installed in place in the appliance.



Figure 1. Selecting Flat Rocks for Pilot Cover

3. The rock media placement jig must remain in place while rock media is placed on the basepan and around the pilot bracket.
4. Place an even layer of rock media around the base pan as shown in Figure 2 and Figure 3. Do not place rock media in the slot over the burner ports. See Figures 2 and 3. Figure 2 shows an outline of the burner tracks and the area in front of the pilot assembly. No rock media may be placed in the outlined area. Continue to place an even amount of rock media over the entire base pan. **DO NOT** install rock media in between the tracks over the entire length of the burner. This may cause lighting issues, undesirable burner flame, or delayed ignition.

### ⚠ WARNING

#### Delayed Ignition Risk

- Place rock media according to instructions.
- Do NOT place rock media in area in front of pilot or between burner tracks.
- Do NOT place rock media pieces in a position that they may fall into area in front of pilot.
- Do NOT use any media other than the rock media supplied with this fireplace.
- Do NOT exceed one layer of rock media on base pan.

Fireplace will not function properly.  
Delayed ignition may occur.

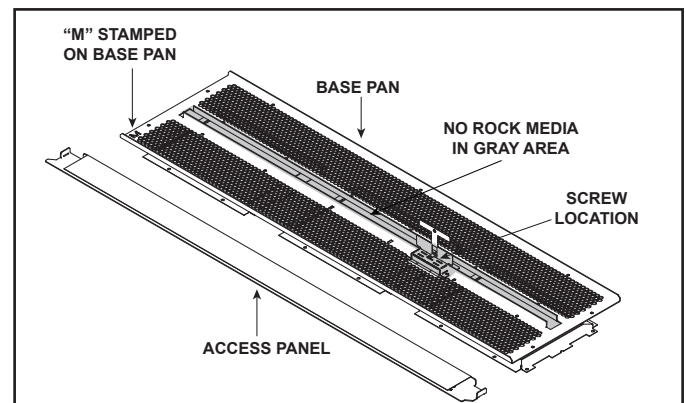

Figure 2. Location of Rock Media Placement Jig

**WARNING! Risk of Fire. DO NOT** place rock media directly in front of the pilot assembly or between the burner tracks over the burner ports.





Figure 3. Place Rock Media

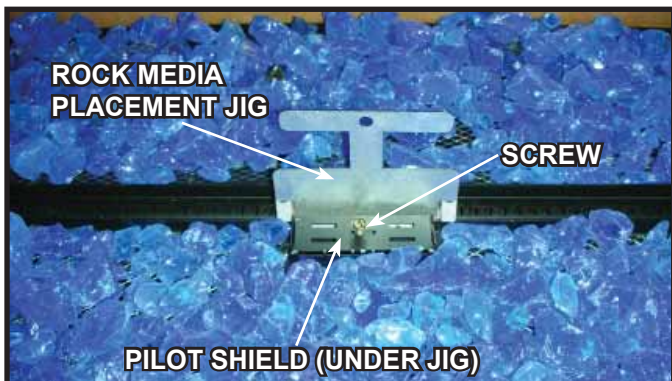

Figure 4. Placing Rock Media in Base Pan on Top of Mesh.

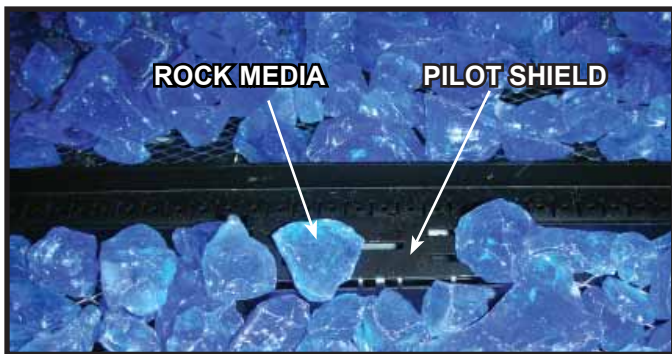

Figure 5. Placing Rock Media Over Pilot Shield.

- Remove the rock media placement jig by removing the screw as noted in Figure 4. Using the flat rock media pieces that were sorted out in Step 1, place one layer over the pilot shield. See Figure 5.
- Place the glass frame assembly back on the appliance. Assure that there is no rock media between the glass and the firebox. Rock media in this area will prevent the glass gasket from sealing.

<b>⚠ WARNING</b>	
	Risk of Asphyxiation or Fumes.
	• Place rock media according to instructions.
	• Do NOT place rock media in area between glass and firebox.
	• Do NOT place rock media pieces in a position that they may fall into area between glass and firebox.
	• Do NOT use any media other than the rock media supplied with this fireplace.
Fireplace will not function properly. Gas leak could occur.	



Figure 6. Front Access Media Tray

- Position the front tabs of the front access media tray toward the glass and then place in the groove of the glass frame. Line up the media tray so that the left and right cut-outs fit within the glass frame.



Figure 7. Location of Clear Tape

**CAUTION! DO NOT remove clear tape located on bottom of media tray. Appliance will overheat and shut down.**



Figure 8. Placing Rock Media in Front Tray.

- Place rock media in the front tray. For an “Infinity” look, the media may be placed up against the glass and tray. This step may only be done when the fireplace is not activated and the glass is cool. The “Infinity” look of the media provides a perception that there is no glass on the appliance, while maintaining the sealed combustion of the appliance.

- Replace side panels and secure in place by using clips on the side of the appliance. Replace refractory and glass assembly.

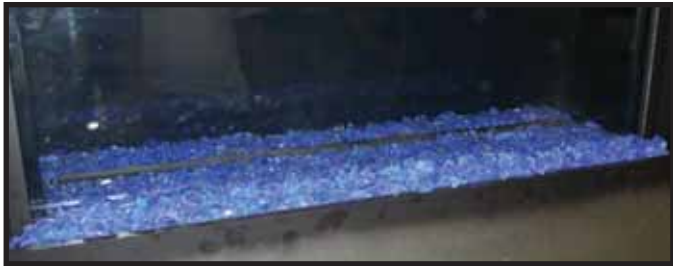

Figure 9. Rock Media Installed.

## F. Porcelain Instructions

A Porcelain Kit is available for use with the RED60 models. Install Porcelain according to these instructions.

**CAUTION! Risk of Cuts or Abrasions.** Wear protective gloves and safety glasses during installation. Sheet metal edges are sharp.

### Preparation

**CAUTION! Risk of Burns!** The fireplace should be turned off and cooled before rock media is installed.

**NOTICE:** The installation of the porcelain kit may require the air shutter setting to be changed. See Section 9.E of this manual to ensure the shutter gap is set correctly before firing the appliance.

- Remove glass assembly. See Section 11.A for instructions.
- Remove any refractory, side panels or media currently installed in appliance. After removing these items, the base pan will be visible on the inside of the appliance.

**Note:** Optional Porcelain or Granite Kits used with lighted and non-lighted media models must be placed in appliance before placing glass media in the appliance.

## RED60 Model Without Media

This kit contains the components necessary to install the porcelain on RED60 models that do not have media installed.

### Kit Contents:

- Inner back panel. See Figure 1.
- Inner side panels. See Figure 2.
- Outside corner trim pieces. See Figure 3.
- Angle tabs and (7) Sheet metal screws. See Figure 4.
- Rear inside base. See Figure 5.
- Front Inside base. See Figure 6.
- Outside front trim base. See Figure 7.
- Inside Base Mesh. See Figure 8.

### Tools Required

- Cordless Drill
- 1/4 inch hex head driver tip
- Flat Blade Screwdriver



Figure 1. Inner Back Panel.

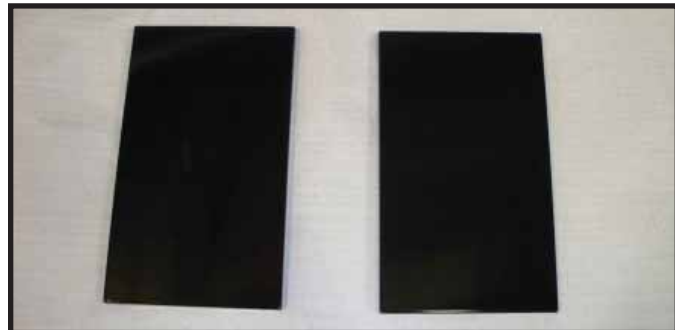

Figure 2. Inner Side Panels.



Figure 3. Outside Corner Trim Pieces.



Figure 4. Angle Tabs with Screws.



Figure 5. Rear Inside Base Piece.



Figure 6. Front Inside Base Piece.



Figure 7. Outside Front Trim Base Piece.



## Installation

1. Verify the correct base pan is in the appliance before proceeding with the porcelain installation. The base pan required for this application has the letters “NNN” and “NNP” stamped in it. See Figure 8. If the base pan does not have these letters stamped in it, contact your dealer.



Figure 8. Location of Base Pan Identification

2. Begin by placing the back panel into the firebox, bottom side first, then tilt top backward into position. Secure with angle tabs and screws in the three pilot holes that are located on the top of the firebox. See Figure 9.
3. Place each side panel into firebox, bottom side first, then tilt top backward into position. Secure with angle tabs and screws in the pilot holes that have are located on the top of the firebox. See Figure 10.



Figure 9. Fastening Angle Tab to Secure Inner Back Panel.



Figure 10. Fastening Angle Tab to Secure Inner Side Panel.

4. Place rear inside porcelain base piece. Place into bottom of fireplace with tabs away from the burner. Center from front to back. There will be a gap between the front edge of the base piece and the burner area and also a gap between the back of the porcelain piece and the rear porcelain panel. These two gaps should be equal. See Figure 11.
5. Install front inside porcelain base piece. Position into bottom of fireplace with tabs facing the outside edge of the firebox. Center from front to back. There will be a gap between the front edge of the base piece and the front of the firebox and also a gap between the back of the porcelain piece and the burner rail. These two gaps should be equal. See Figure 11.

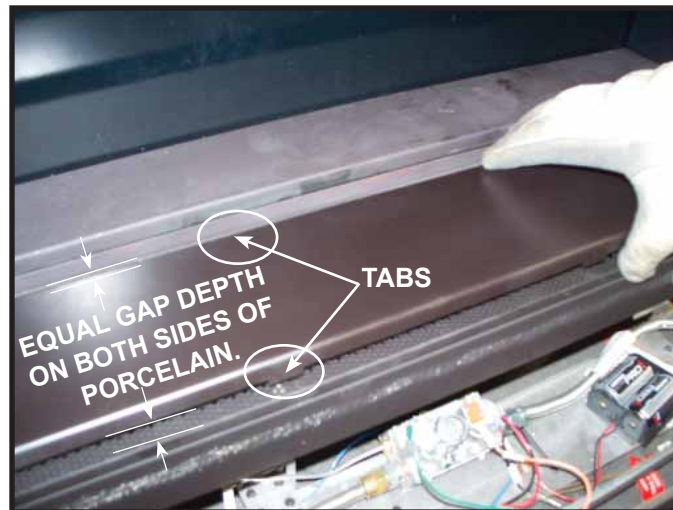

Figure 11. Placing Porcelain Base Pieces.

6. Install glass frame assembly and spring lock into position. Set front porcelain trim shelf into position.
7. Position trim shelf so tabs are facing the glass assembly. Insert into glass frame. See Figure 12.



Figure 12. Positioning Porcelain Access Panel.



Figure 13. Porcelain Trim Shelf Installed.

8. Place outside front trim base onto shelf. Place so the cutouts are in line with the outside edges of the glass frame. See Figure 14.



Figure 14. Porcelain Trim Base Installed.

9. Install four retainer clips (included) as shown in Figure 15. Outside corner trim piece will be forced into clip on front of fireplace. See Figure 16 and Figure 17.

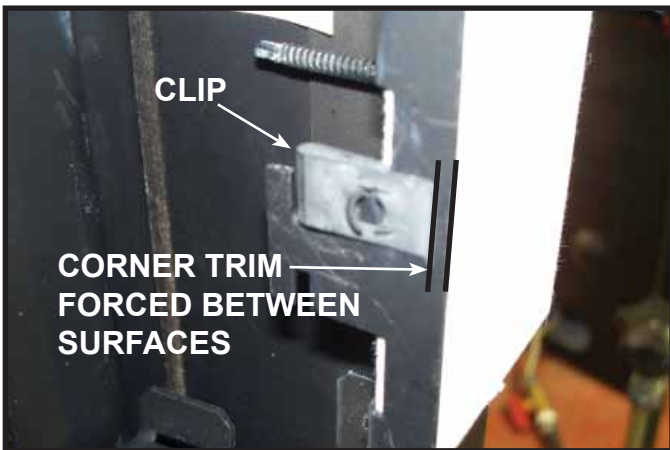

Figure 15. Clips Located on Four Corners - Bottom Right Shown



Figure 16. Installing Outside Corner Trim Piece onto Clip.



Figure 17. Outside Corner Trim Piece Installed.

### Service Parts

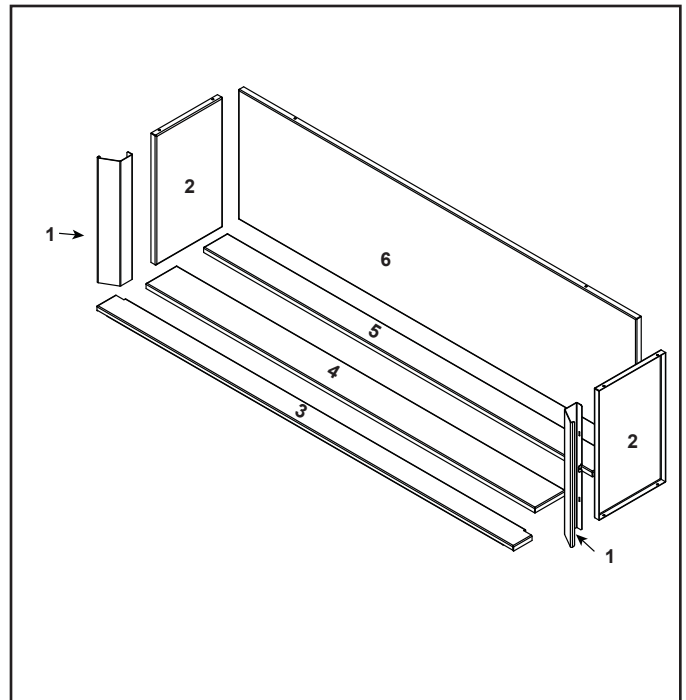

Figure 18. Service Parts Diagram.

ITEM	DESCRIPTION	PART NUMBER
	Refractory Kit	POR60-F
1	Front Corner Panel (Qty 2 req)	2159-229
2	Panel Side (Qty 2 req)	2159-223
3	Outer Bottom Panel	2159-226
4	Bottom Front Panel	2159-224
5	Bottom Back Panel	2159-225
6	Back Panel	2159-222

## RED60 Model With Media

This kit contains the components necessary to install the porcelain on RED60 models that have media installed.

### Kit Contents:

- (1) Inner back panel. See Figure 1.
- (2) Inner side panels. See Figure 2.
- (2) Outside corner trim pieces. See Figure 3.
- (7) Angle tabs and (7) Sheet metal screws. See Figure 4.

### Tools Required

- Cordless Drill
- 1/4 inch hex head driver tip



Figure 4. Angle Tabs with Screws.

### Installation

1. Verify the correct base pan is in the appliance before proceeding with the porcelain installation. The base pan required for this application has the letter "M" stamped in it. See Figure 5. If the base pan does not have the letter "M" stamped in it, contact your dealer.

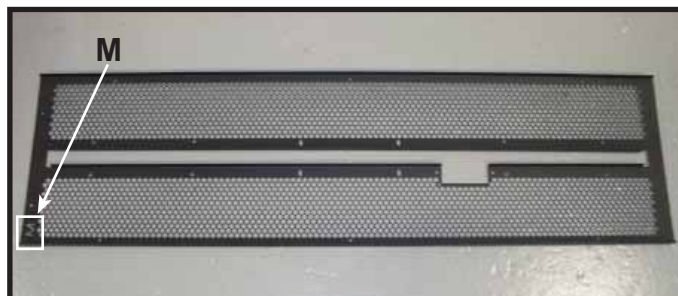

Figure 5. Base Pan

2. Begin by placing back panel. Place bottom in first and tilt top backward carefully until it touches the back wall. Secure with angle tabs and screws in the three pilot holes that are located on the top of the firebox.



Figure 6. Installing Angle Tab to Secure Inner Back Panel.

3. Using a flat blade screwdriver, bend up the tabs located on each side of the basepan to a 90 degree angle. See Figure 7.
4. Slide each inner side porcelain panel in from the front until it touches the back wall. Secure with angle tabs and screws in the pilot holes that are located on the top of the firebox. See Figure 6.
5. Bend the tabs mentioned on step 3 toward the porcelain panel. See Figure 8.



Figure 1. Inner Back Panel.

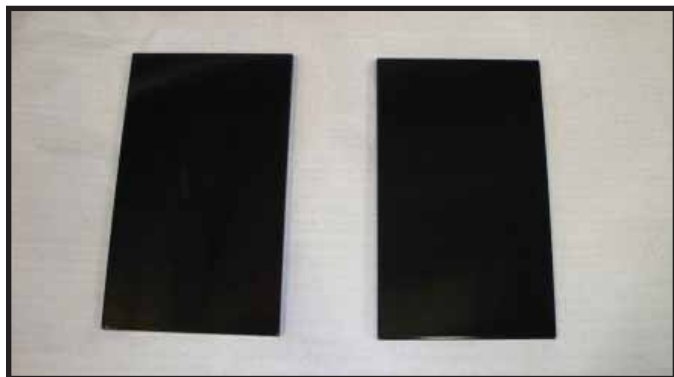

Figure 2. Inner Side Panels.



Figure 3. Outside Corner Trim Pieces.





Figure 7. Bend Tabs Up to a 90 Degree Angle.

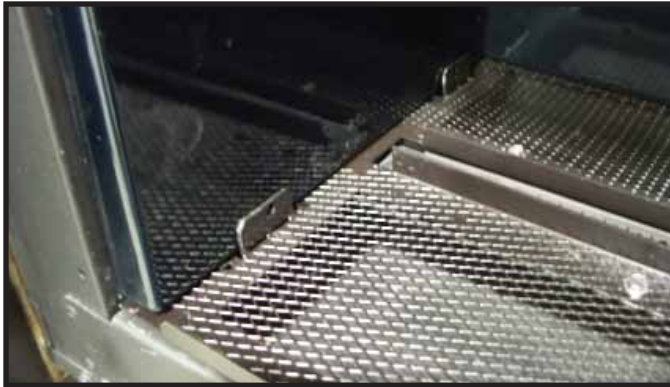

Figure 8. Bend Tabs Toward Panel

6. Install glass rocks in base of firebox according to glass media installation instructions.
7. Install glass frame assembly according to instructions in installation manual.
8. Install front media tray.
9. Install four retainer clips (included) as shown in Figure 9. Outside corner trim piece will be forced into clip on front of fireplace. See Figure 10 and Figure 11.

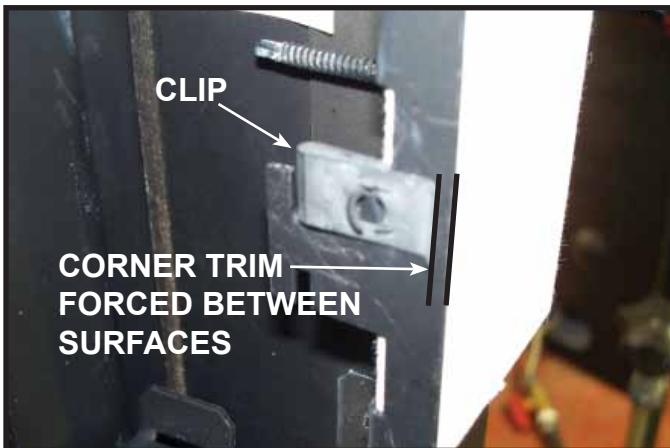

Figure 9. Clip Location.

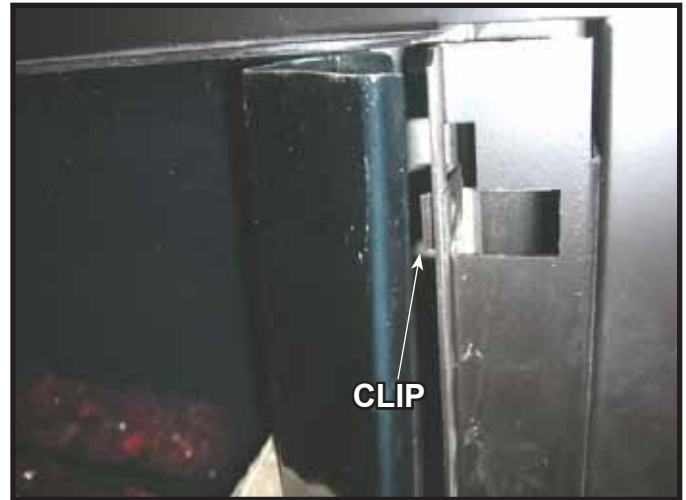

Figure 10. Installing Outside Corner Trim Piece onto Clip.



Figure 11. Installing Outside Corner Trim Piece onto Clip.

### **⚠ WARNING**



#### Delayed Ignition Risk

- Place glass rock according to instructions.
- Do NOT place glass rock in area in front of pilot or between burner tracks.
- Do NOT place glass rock in a position that they may fall into area in front of pilot.
- Do NOT use any media other than what is supplied with this fireplace.
- Do NOT use more than three 10 lb. bags of glass rock per fireplace (when applicable).
- Do NOT use more than five bags of media in the fireplace (when applicable).

Fireplace will not function properly.  
Delayed ignition could occur.



## Service Parts

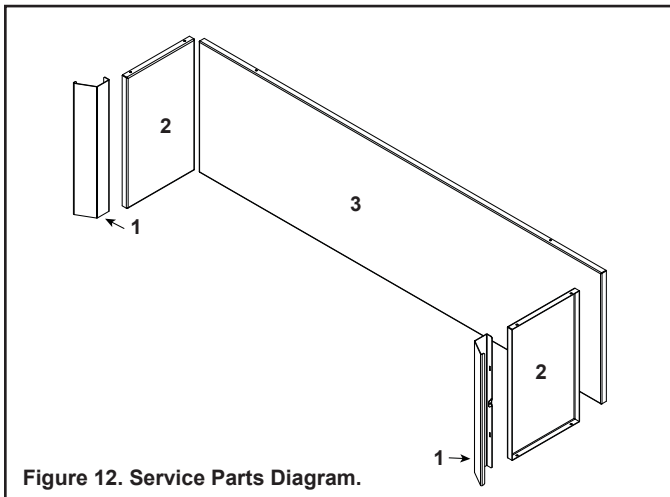

Figure 12. Service Parts Diagram.

ITEM	DESCRIPTION	PART NUMBER
	Refractory Kit	POR60-L
1	Side Panel (Qty 2 req)	2159-219
2	Panel Side (Qty 2 req)	2159-223
3	Back Panel	2159-222

## G. Granite Instructions

A Granite Kit is available for use with the RED60 models. Install Granite according to these instructions.

**CAUTION! Risk of Cuts or Abrasions.** Wear protective gloves and safety glasses during installation. Sheet metal edges are sharp.

**NOTICE: Handle granite pieces with care. Granite may chip or crack if dropped or impacted.**

**Note:** Optional Porcelain or Granite Kits used with lighted and non-lighted media models must be placed in appliance before placing glass media in the appliance.

**NOTICE:** The installation of the granite kit may require the air shutter setting to be changed. See Section 9.E of this manual to ensure the shutter gap is set correctly before firing the appliance.

### Preparation

**CAUTION! Risk of Burns!** The fireplace should be turned off and cooled before rock media is installed.

1. Remove glass assembly. See Section 11.A for instructions.
2. Remove any refractory, side panels or media currently installed in appliance. After removing these items, the base pan will be visible on the inside of the appliance.

### Kit Contents:

- (3) Back panel pieces 19-13/16 inches wide x 16-7/8 inches tall. See Figure 1.
- (2) Inner side wall pieces 10 inches wide x 16-7/8 inches tall. See Figure 2.
- (2) Outside corner trim pieces. See Figure 3.
- (7) Securing tabs. See Figure 4.
- (7) Sheet metal screws. See Figure 4.

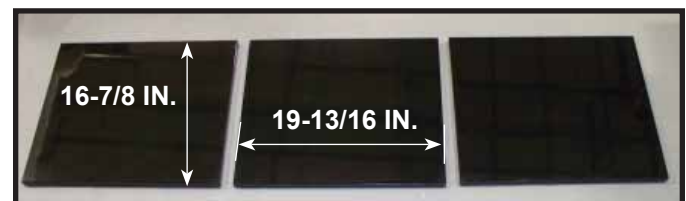

Figure 1. Back Panel Pieces.

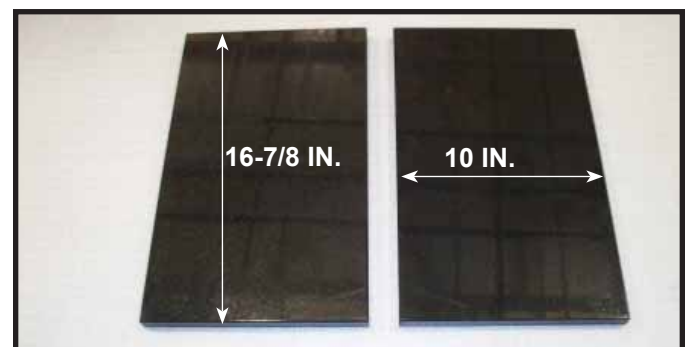

Figure 2. Inner Side Wall Pieces.



Figure 3. Outside Corner Trim Pieces.



Figure 4. Securing Tabs and Sheet Metal Screws.

**Tools Required:**

- Cordless Drill
- 1/4 inch hex head driver tip
- Pry Bar and Hammer for opening shipping crate.

**Installation**

1. Begin by removing back row and sides of quarter inch sheet metal screws from base pan as shown in Figure 5. The screws will be located either on top of or underneath the mesh. If underneath mesh, lift mesh screen up and remove for access to screw heads. After removing screws replace mesh before installing granite.



Figure 5. Removing Screws from Basepan.

2. Measure granite to ensure you are installing the pieces in the right orientation. Back panel pieces are to be placed first. These pieces are wider than they are tall. Install so that width is 19-13/16 inches. Begin installing pieces left to right. Place granite into firebox, bottom side first, then tilt top backward into position. Place the first piece on the left and move to right as you add the other pieces. See Figure 6.

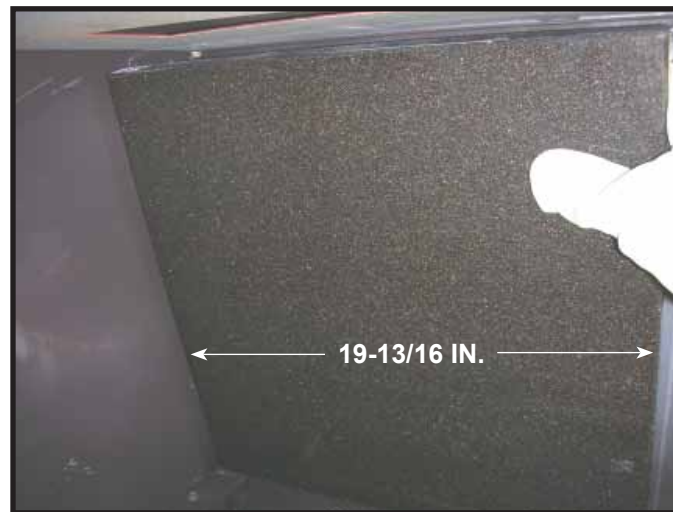

Figure 6. Placing Back Panel Piece.

3. Secure granite pieces using angle tabs and screws provided. See Figure 7. Secure each piece as it is placed into position to keep it from falling while placing next piece into firebox. Continue with back middle piece and then back right side.



Figure 7. Fastening Angle Tabs to Secure Granite in Place.

4. Slide side pieces into place from the front and hold in place while installing the angle tabs and screws provided. Measure to be sure that the pieces are placed in the correct orientation. For the side pieces, the width is the 10 inch dimension.



Figure 8. View of Back and Side Piece Installed.

5. **For models with rock media only:** Install glass rocks in base of firebox according to glass media installation instructions. Install glass frame assembly and spring lock into place.

**⚠ WARNING**

**Delayed Ignition Risk**

- Place rock media according to instructions.
- Do NOT place rock media in area in front of pilot or between burner tracks.
- Do NOT place rock media in a position that they may fall into area in front of pilot.
- Do NOT use any media other than what is supplied with this fireplace.
- Do NOT use more than three 10 lb. bags of rock media per fireplace.
- Do NOT use more than five bags of media in the fireplace (when applicable).

Fireplace will not function properly.  
Delayed ignition could occur.

6. **For models with rock media only:** Install front media tray. Do not place glass rock media at this time.
7. Install outer corner granite trim pieces. Slowly slide into position as shown in picture. Use securing tabs to hold in place. Tabs attach at the top using sheet metal screws and pilot holes located above the granite. See Figure 9 and Figure 10.

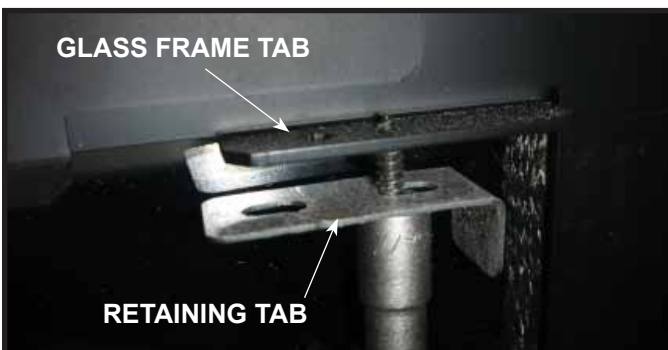
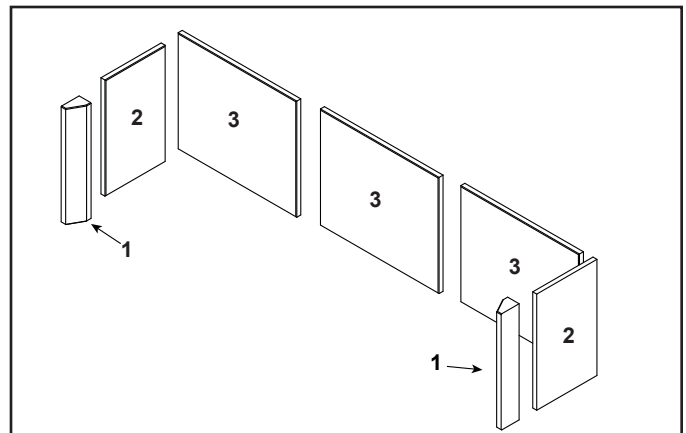

Figure 9. Attaching Retaining Tab to Glass Frame Tab.



Figure 10. Placing Outer Corner Granite Trim Piece.

8. **For models with rock media only:** Place glass rock media in front media tray according to glass media installation instructions.
9. Install the glass frame assembly.
10. Position access panel so tabs are facing the glass assembly. Insert into glass frame.
11. Install outer front trim base onto shelf.



ITEM	DESCRIPTION	PART NUMBER
	Refractory Kit	GR60-L
1	Side Panel (Qty 2 req)	2159-211
2	Panel Side (Qty 2 req)	2159-210
3	Back Panel (Qty 3 req)	2159-209

Figure 11. Service Parts Diagram.

## H. Sheet Metal Refractory Instructions

A Sheet Metal Refractory Kit is available for use with the RED60 models. This kit contains the components necessary to install metal refractory on the RED60-NNN model. Install Sheet Metal Refractory Kit according to these instructions.

**CAUTION! Risk of Cuts or Abrasions.** Wear protective gloves and safety glasses during installation. Sheet metal edges are sharp.

**NOTICE:** The installation of the sheet metal refractory kit may require the air shutter setting to be changed. See Section 9.E of this manual to ensure the shutter gap is set correctly before firing the appliance.

### Kit Contents:

- (2) Outside corner trim pieces. See Figure 1.
- (1) Front Inside base. See Figure 2.
- (1) Rear Inside base. See Figure 2.
- (1) Outside front trim base. See Figure 3.

### Tools Required

- Cordless Drill
- 1/4 inch hex head driver tip

### Preparation

**CAUTION! Risk of Burns!** The fireplace should be turned off and cooled before the sheet metal refractory is installed.

1. Remove glass assembly. See appliance Installation Manual for instructions.
2. Remove any refractory, side panels or media currently installed in appliance. After removing these items, the base pan will be visible on the inside of the appliance.
3. Verify that the correct basepan is installed inside the appliance.



Figure 1. Location of Base Pan Identification



Figure 2. Outside Corner Trim Pieces.

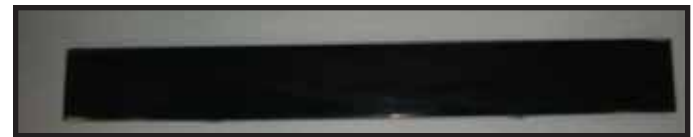

Figure 3. Front and Rear Inside Base Piece.



Figure 4. Outside Front Trim Base Piece.

### Installation

1. Install rear inside base piece. Position piece into bottom of fireplace with tabs facing the burner. Center piece from front to back. There will be a gap between the front edge of the base piece and the burner area and also a gap between the back of the base piece and the rear firebox panel. These two gaps should be equal. See Figure 5.
2. Install front inside base piece. Position piece into bottom of fireplace with tabs facing the outside edge of the firebox. Center from front to back. There will be a gap between the front edge of the base piece and the front of the firebox and also a gap between the back of the base piece and the burner rail. These two gaps should be equal. See Figure 5.

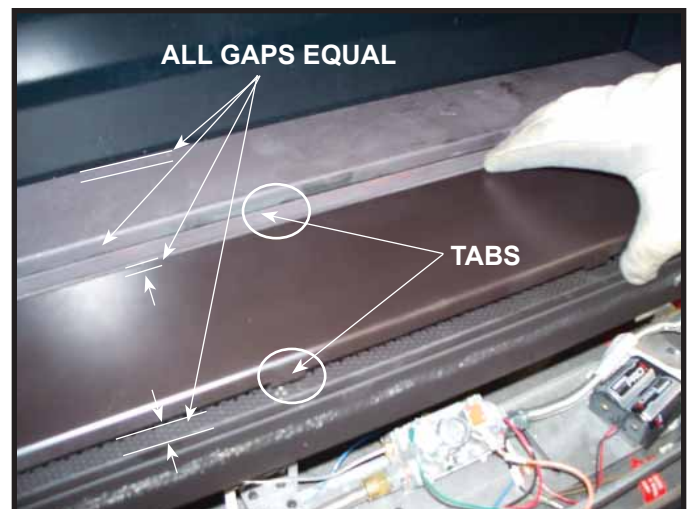

Figure 5. Placing Base Pieces.



3. Install glass frame assembly and spring lock into position according to instructions in appliance installation manual. Set access panel into position.
4. Position access panel so tabs are facing the glass assembly. Insert into glass frame. See Figure 6 and Figure 7.

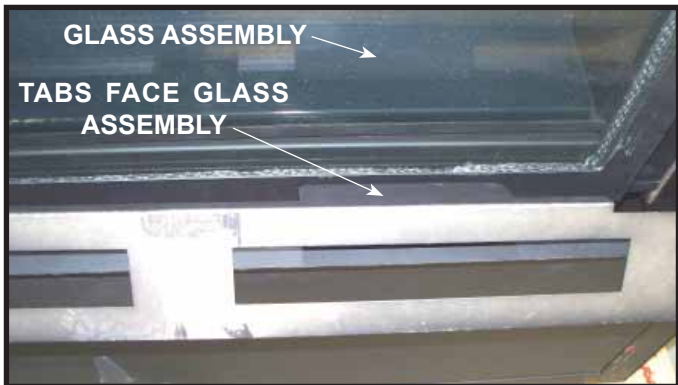

Figure 6. Positioning Access Panel.

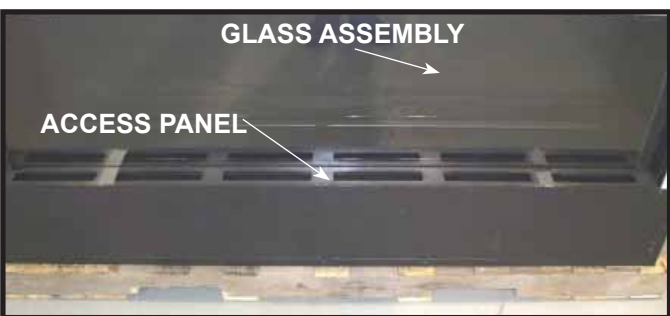

Figure 7. Access Panel Installed.

5. Place outside front trim base onto access panel. Place so the cutouts are in line with the outside edges of the glass frame. See Figure 8.



Figure 8. Outside Front Trim Base Installed.

6. Install four retainer clips (included) as shown in Figure 8. Outside corner trim pieces will be forced into clip on front of appliance. See Figure 9 and Figure 10.

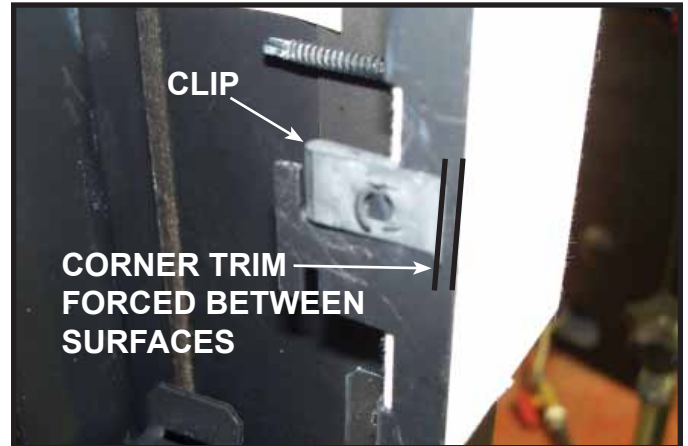

Figure 8. Clip Location.



Figure 9. Installing Outside Corner Trim Piece onto Clip.



Figure 10. Outside Corner Trim Piece Installed.

## Service Parts

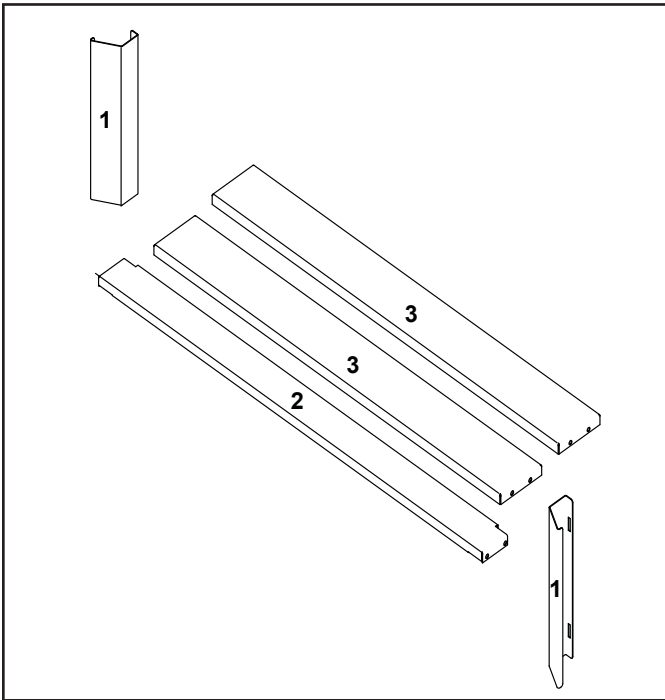

Figure 11. Service Parts Diagram.

## I. Install the Mesh

A mesh front is included with the RED60 appliance. For installation instructions, see section 10.C.

ITEM	DESCRIPTION	COMMENTS	PART NUMBER
	Metal Refractory Kit (RED60)		SMR-60NL
1	Panel Side No Lights		2159-237
2	Exterior Panel Cover		2159-239
3	Interior No Light Base		2159-238



# 12 Reference Materials

## A. Vent Components Diagrams

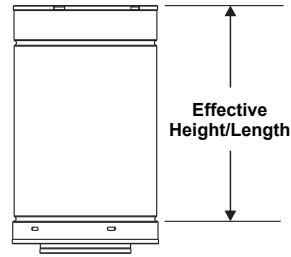

DVP Pipe (see chart)

Pipe	Effective Length	
	Inches	Millimeters
DVP4	4	102
DVP6	6	152
DVP12	12	305
DVP24	24	610
DVP36	36	914
DVP48	48	1219
DVP6A	3 to 6	76 to 152
DVP12A	3 to 12	76 to 305

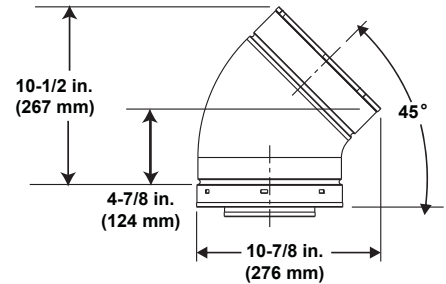

DVP45 (45° Elbow)

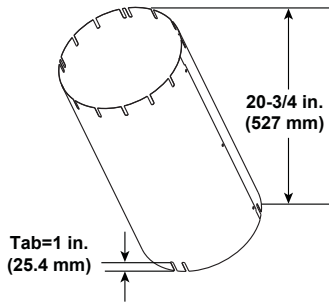

Finished Height: 19-3/4 in./502 mm  
UNIV-AS2 (Attic Insulation Shield)

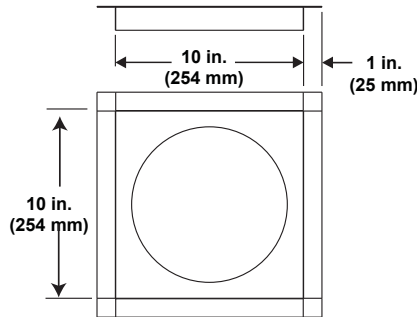

DVP-FS (Ceiling Firestop)

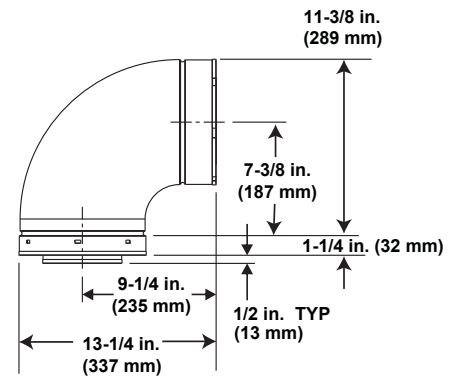

DVP90ST (90° Elbow)

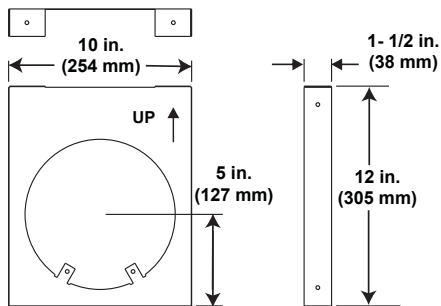

DVP-HVS (Vent Support)

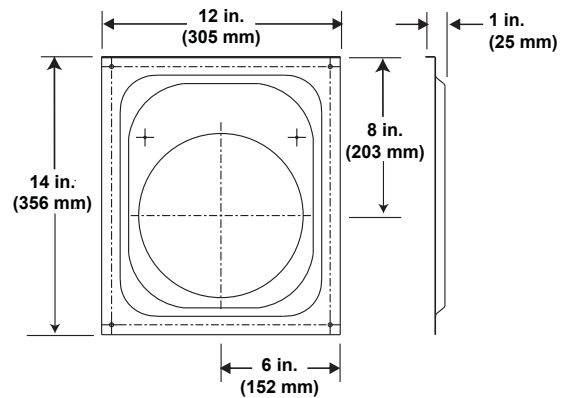

DVP-WS (Wall Shield Firestop)

Figure 12.1 DVP vent components

## A. Vent Components Diagrams (continued)

Note: Heat shields **MUST** overlap by a minimum of 1-1/2 in. (38 mm). **The heat shield is designed to be used on a wall 4 in. to 7-1/4 in. (102 mm to 184 mm) thick.** If wall thickness is less than 4 in. (102 mm) the existing heat shields must be field trimmed. If wall thickness is greater than 7-1/4 in. (184 mm) a DVP-HSM-B will be required.

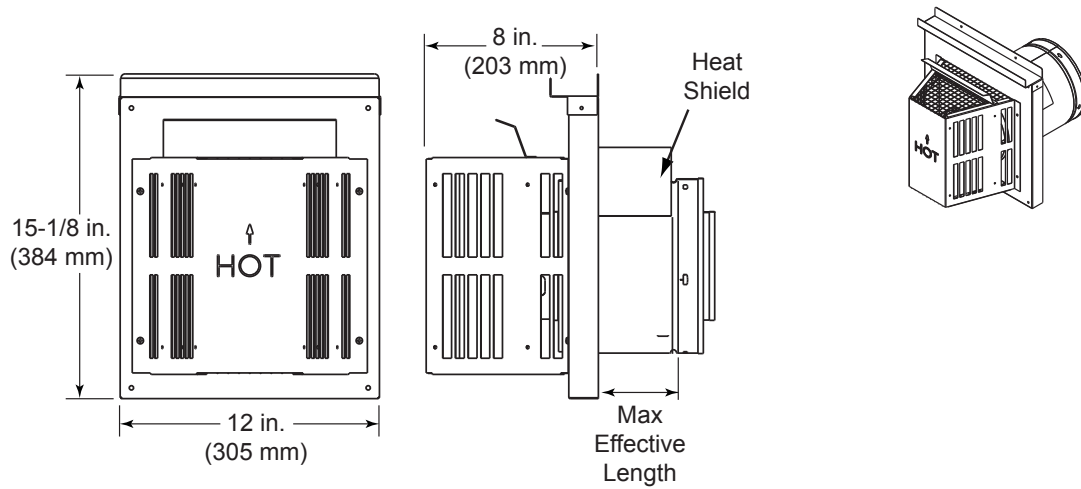

**DVP-TRAP**  
Horizontal Termination Cap

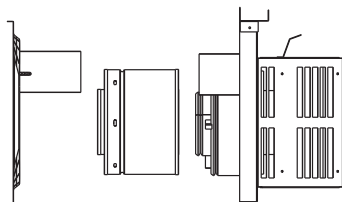

**DVP-TRAP1**

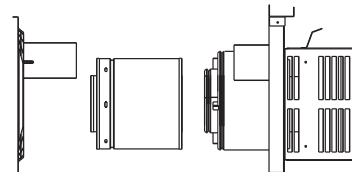

**DVP-TRAP2**

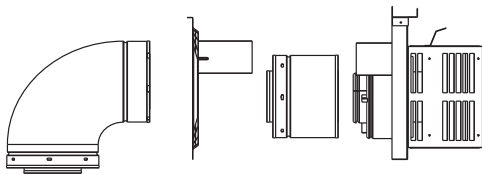

**DVP-TRAPK1**

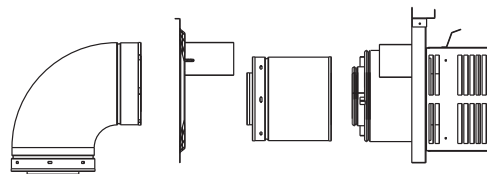

**DVP-TRAPK2**

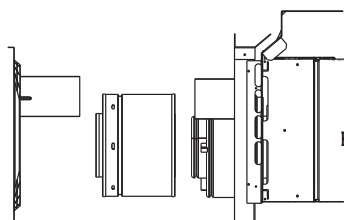

**DVP-HPC1**

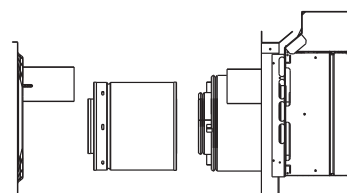

**DVP-HPC2**

Figure 12.2 DVP vent components

**A. Vent Components Diagrams (continued)**

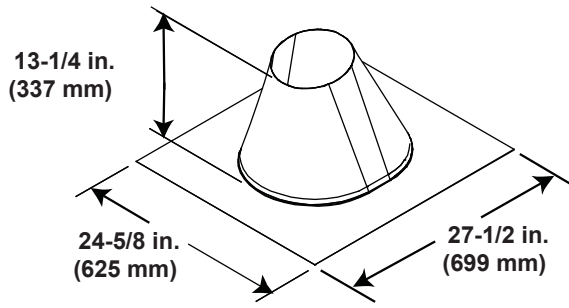

**RF6M**  
Roof Flashing Multi-pak

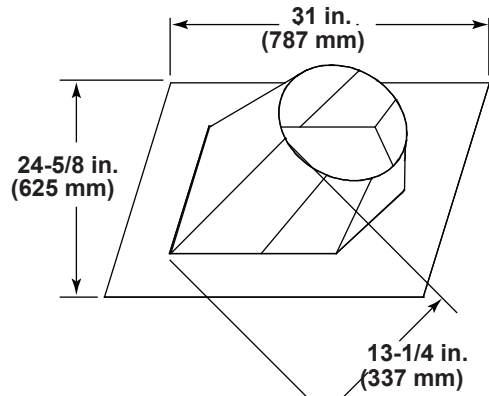

**RF12M**  
Roof Flashing Multi-pak

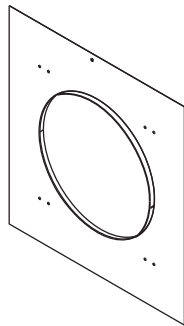

**DVP-TRAPFL**  
Flashing

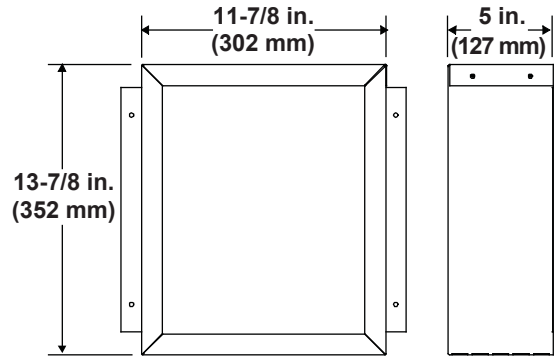

**DVP-BEK2**  
DVP-HPC Cap Brick Extension

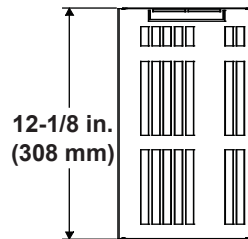
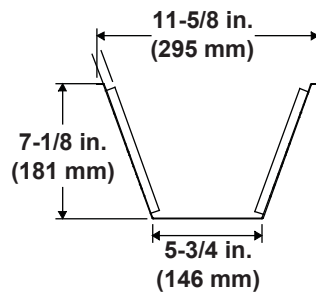

**COOL-ADDM**  
Cap Shield

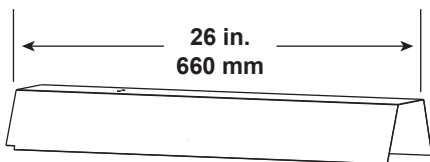
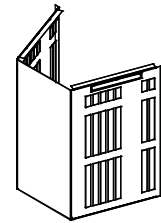

**DVP-HSM-B**  
Extended Heat Shield

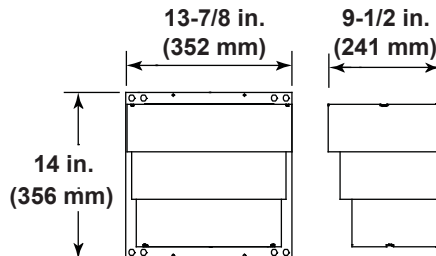

**DRC-RADIUS**  
Cap Shield

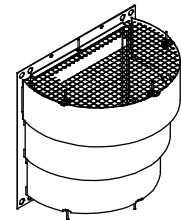
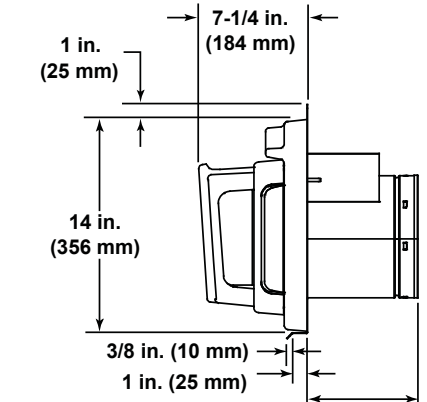
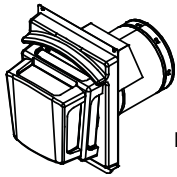

Figure 12.3 DVP vent components

# A. Vent Components Diagrams (continued)



7-3/4 to 10-3/8 in.  
(197 to 264 mm)



**DVP-FBHT**  
FireBrick Termination Cap

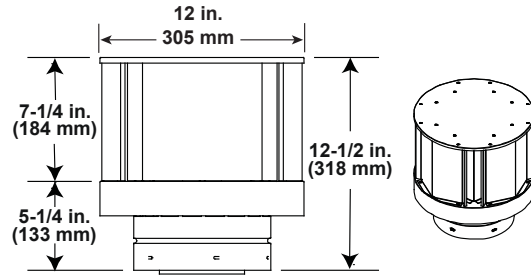

**DVP-TVHW**  
Vertical Termination Cap (Highwind)

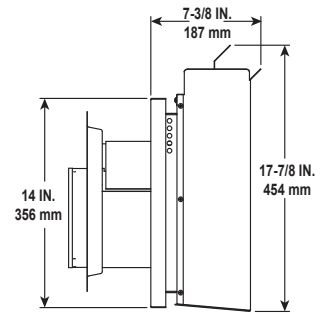
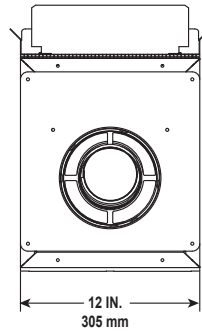

**SLP-TB1**  
Basement Vent Cap

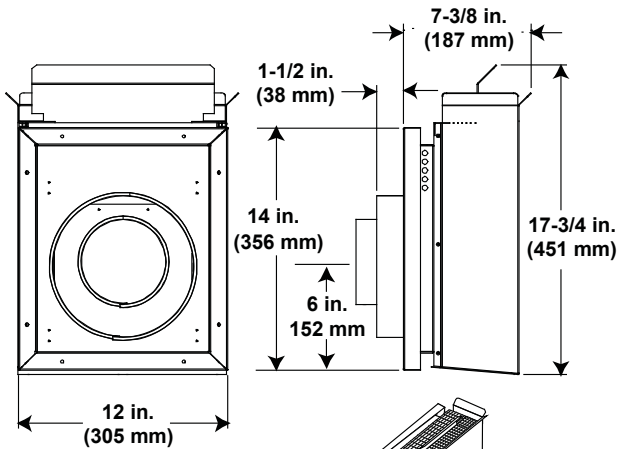
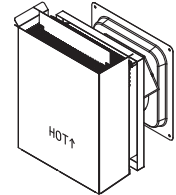

**DVP-TB1**  
Basement Vent Cap

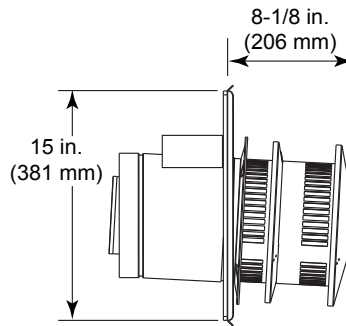
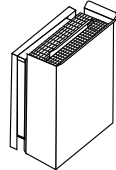

**DVP-HRC-SS NOT APPROVED FOR ALL UNITS.  
NOT FOR USE WITH LP FUEL**

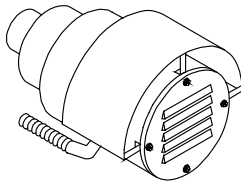
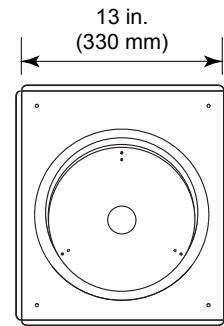

**PVK-80**

(For use with IPI and DSI appliances only.)

**NOTE: PVK-80 has specific wiring and venting requirements for use on the RED60 model. Refer to Section 7 for installation instructions.**

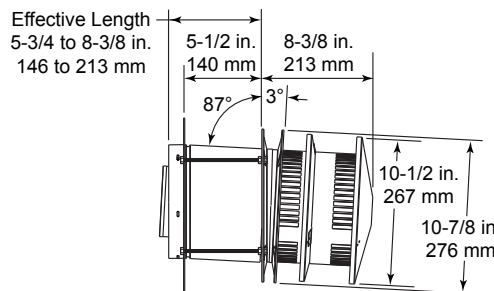

**DVP-HRC-ZC-SS NOT APPROVED FOR ALL UNITS.  
NOT FOR USE WITH LP FUEL**

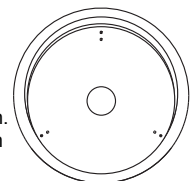

Figure 12.4 DVP vent components

## **B. Accessories**

### **Wall Controls and Wall Switches**

Follow the instructions supplied with the control installed to operate your fireplace:

For safety:

- Install a switch lock or a wall//remote control with child protection lockout feature.
- Keep remote controls out of reach of children.

See your dealer if you have questions.

Heat & Glo, a brand of Hearth & Home Technologies  
7571 215<sup>th</sup> Street West, Lakeville, MN 55044  
[www.heatnglo.com](http://www.heatnglo.com)

Please contact your Heat & Glo dealer with any questions or concerns.  
For the location of your nearest Heat & Glo dealer,  
please visit [www.heatnglo.com](http://www.heatnglo.com).

*Printed in U.S.A. - Copyright 2015*