

# Owner's Manual

## Care and Operation

**INSTALLER:** Leave this manual with party responsible for use and operation.

**OWNER:** Retain this manual for future reference.

→ Contact your dealer with questions regarding installation, operation or service.

**NOTICE:** DO NOT discard this manual!

**HEAT & GLO**

No one builds a better fire

**Models:**

**RED40**

**RED40ST**

**GAS-FIRED**

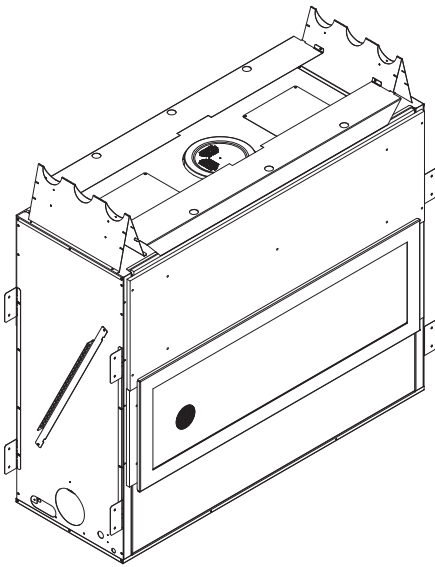

This appliance may be installed as an OEM installation in manufactured home (USA only) or mobile home and must be installed in accordance with the manufacturer's instructions and the *Manufactured Home Construction and Safety Standard, Title 24 CFR, Part 3280* in the United States, or the *Standard for Installation in Mobile Homes, CAN/CSA Z240 MH Series*, in Canada.

This appliance is only for use with the type(s) of gas indicated on the rating plate. This appliance is not convertible for use with other gases, unless a certified kit is used.

**⚠ WARNING:** If the information in these instructions is not followed exactly, a fire or explosion may result causing property damage, personal injury, or death.

- **DO NOT** store or use gasoline or other flammable vapors and liquids in the vicinity of this or any other appliance.
- **What to do if you smell gas**
  - **DO NOT** try to light any appliance.
  - **DO NOT** touch any electrical switch. **DO NOT** use any phone in your building.
  - Immediately call your gas supplier from a neighbor's phone. Follow the gas supplier's instructions.
  - If you cannot reach your gas supplier, call the fire department.
- Installation and service must be performed by a qualified installer, service agency, or the gas supplier.

**⚠ WARNING**



**HOT GLASS WILL CAUSE BURNS.  
DO NOT TOUCH GLASS UNTIL COOLED.  
NEVER ALLOW CHILDREN TO TOUCH GLASS.**

A barrier designed to reduce the risk of burns from the hot viewing glass is provided with this appliance and shall be installed.

In the Commonwealth of Massachusetts installation must be performed by a licensed plumber or gas fitter. See Table of Contents for location of additional Commonwealth of Massachusetts requirements.

# 1 Welcome

Read this manual before operating this appliance.  
Please retain this Owner's Manual for future reference.

Read the Installation Manual before making any installation or finishing changes.

## A. Congratulations

Congratulations on selecting a Heat & Glo gas fireplace, an elegant and clean alternative to wood burning fireplaces. The Heat & Glo gas fireplace you have selected is designed to provide the utmost in safety, reliability, and efficiency.

As the owner of a new fireplace, you'll want to read and carefully follow all of the instructions contained in this owner's manual. Pay special attention to all cautions and warnings.

This owner's manual should be retained for future reference. We suggest that you keep it with your other important documents and product manuals.

The information contained in this owner's manual, unless noted otherwise, applies to all models and gas control systems.

Your new Heat & Glo gas fireplace will give you years of durable use and trouble-free enjoyment. Welcome to the Heat & Glo family of fireplace products!

### Local Dealer Information

**DEALER:** Fill in your name, address, phone and email information here and appliance information below.

Dealer Name: \_\_\_\_\_  
 Address: \_\_\_\_\_  
 \_\_\_\_\_  
 Phone: \_\_\_\_\_  
 Email: \_\_\_\_\_

#### Appliance Information:

Brand: \_\_\_\_\_ Model Name: \_\_\_\_\_  
 Serial Number: \_\_\_\_\_ Date Installed: \_\_\_\_\_

### Listing Label Information/Location

The model information regarding your specific fireplace can be found on the rating plate usually located in the control area of the fireplace.

**HEAT & GLO** Heat & Glo, a brand of Hearth & Home Technologies  
 No one builds a better fire 7571 215th Street West, Lakeville, MN 55044

**GAS-FIRED**  
**UL US LISTED**

Not for use with solid fuel.  
 (Ne doit pas être utilisé avec un combustible solide).

Type of Gas (Sorte De Gaz): This appliance must be installed in accordance with local codes, if any; if not, follow ANSI Z223.1 in the USA or CAN/CSA B149 installation codes. (Installer l'appareil selon les codes ou règlements locaux ou, en l'absence de tels règlements, selon les codes d'installation CAN/CSA-B149.)

**NATURAL GAS**  
 ANSI Z21XX-XXXX · CSA 2.XX-MXX

Minimum Permissible Gas Supply for Purposes of Input Adjustment.			
Approved Minimum (De Gaz) Acceptable	0.0 in w.c.	(Po. Col. d'eau)	
Maximum Pressure (Pression)	0.0 in w.c.	(Po. Col. d'eau)	
Maximum Manifold Pressure (Pression)	0.0 in w.c.	(Po. Col. d'eau)	
Minimum Manifold Pressure (Pression)	0.0 in w.c.	(Po. Col. d'eau)	

Total Electrical Requirements: 000Vac, 00Hz., less than 00 Amperes **MADE IN USA**

ALTITUDE:	0-0000 FT.	IN CANADA	0000-0000FT.	Model:	XXXXXXXX
MAX. INPUT BTUH:	00,000		00,000	(Modele):	
MIN. INPUT BTUH:	00,000		00,000	Serial	XXXXXXXX
ORIFICE SIZE:	#XXXXX		#XXXXX	(Serie):	

## ▲ Safety Alert Key:

- **DANGER!** Indicates a hazardous situation which, if not avoided will result in death or serious injury.
- **WARNING!** Indicates a hazardous situation which, if not avoided could result in death or serious injury.
- **CAUTION!** Indicates a hazardous situation which, if not avoided, could result in minor or moderate injury.
- **NOTICE:** Used to address practices not related to personal injury.

# Table of Contents

## 1 Welcome

- A. Congratulations . . . . . 2
- B. Limited Lifetime Warranty. . . . . 4

## 2 Product Specific Information

- A. Appliance Certification . . . . . 6
- B. Glass Specifications . . . . . 6
- C. BTU Specifications. . . . . 6

## 3 Important Safety and Operating Information

- A. Appliance Safety . . . . . 7
- B. General Operating Parts . . . . . 8
- C. Fuel Specifications. . . . . 8
- D. Before Lighting Appliance. . . . . 8
- E. Lighting Instructions (IPI) . . . . . 9
- F. Appliance Break-In. . . . . 10
- G. Heat Management . . . . . 10
- H. Detailed Component Operating Instructions . . . . . 10

## 4 Maintenance and Service

- A. Maintenance: Frequency and Tasks . . . . . 11
- B. Maintenance Tasks-Homeowner . . . . . 11
- C. Maintenance Tasks-Qualified Service Technician . . . . . 13

## 5 Troubleshooting and Frequently Asked Questions

- A. Frequently Asked Questions . . . . . 14
- B. Troubleshooting . . . . . 15

## 6 Reference Materials

- A. Accessories . . . . . 17
- B. Service Parts . . . . . 18
- C. Contact Information . . . . . 30

→ = Contains updated information.

## B. Limited Lifetime Warranty

### Hearth & Home Technologies LIMITED LIFETIME WARRANTY

Hearth & Home Technologies, on behalf of its hearth brands ("HHT"), extends the following warranty for HHT gas, wood, pellet, coal and electric hearth appliances that are purchased from an HHT authorized dealer.

#### **WARRANTY COVERAGE:**

HHT warrants to the original owner of the HHT appliance at the site of installation, and to any transferee taking ownership of the appliance at the site of installation within two years following the date of original purchase, that the HHT appliance will be free from defects in materials and workmanship at the time of manufacture. After installation, if covered components manufactured by HHT are found to be defective in materials or workmanship during the applicable warranty period, HHT will, at its option, repair or replace the covered components. HHT, at its own discretion, may fully discharge all of its obligations under such warranties by replacing the product itself or refunding the verified purchase price of the product itself. The maximum amount recoverable under this warranty is limited to the purchase price of the product. This warranty is subject to conditions, exclusions and limitations as described below.

#### **WARRANTY PERIOD:**

Warranty coverage begins on the date of original purchase. In the case of new home construction, warranty coverage begins on the date of first occupancy of the dwelling or six months after the sale of the product by an independent, authorized HHT dealer/ distributor, whichever occurs earlier. The warranty shall commence no later than 24 months following the date of product shipment from HHT, regardless of the installation or occupancy date. The warranty period for parts and labor for covered components is produced in the following table.

The term "Limited Lifetime" in the table below is defined as: 20 years from the beginning date of warranty coverage for gas appliances, and 10 years from the beginning date of warranty coverage for wood, pellet, and coal appliances. These time periods reflect the minimum expected useful lives of the designated components under normal operating conditions.

Warranty Period		HHT Manufactured Appliances and Venting							Components Covered
Parts	Labor	Gas	Wood	Pellet	EPA Wood	Coal	Electric	Venting	
1 Year		X	X	X	X	X	X	X	All parts and material except as covered by Conditions, Exclusions, and Limitations listed
2 years				X	X	X			Igniters, electronic components, and glass
		X	X	X	X	X			Factory-installed blowers
			X						Molded refractory panels
3 years				X					Firepots and burnpots
5 years	1 year			X	X				Castings and baffles
7 years	3 years		X	X	X				Manifold tubes, HHT chimney and termination
10 years	1 year	X							Burners, logs and refractory
Limited Lifetime	3 years	X	X	X	X	X			Firebox and heat exchanger
90 Days		X	X	X	X	X	X	X	All replacement parts beyond warranty period

See conditions, exclusions, and limitations on next page.

## **B. Limited Lifetime Warranty (*continued*)**

### **WARRANTY CONDITIONS:**

- This warranty only covers HHT appliances that are purchased through an HHT authorized dealer or distributor. A list of HHT authorized dealers is available on the HHT branded websites.
- This warranty is only valid while the HHT appliance remains at the site of original installation.
- This warranty is only valid in the country in which the HHT authorized dealer or distributor that sold the appliance resides.
- Contact your installing dealer for warranty service. If the installing dealer is unable to provide necessary parts, contact the nearest HHT authorized dealer or supplier. Additional service fees may apply if you are seeking warranty service from a dealer other than the dealer from whom you originally purchased the product.
- Check with your dealer in advance for any costs to you when arranging a warranty call. Travel and shipping charges for parts are not covered by this warranty.

### **WARRANTY EXCLUSIONS:**

This warranty does not cover the following:

- Changes in surface finishes as a result of normal use. As a heating appliance, some changes in color of interior and exterior surface finishes may occur. This is not a flaw and is not covered under warranty.
- Damage to printed, plated, or enameled surfaces caused by fingerprints, accidents, misuse, scratches, melted items, or other external sources and residues left on the plated surfaces from the use of abrasive cleaners or polishes.
- Repair or replacement of parts that are subject to normal wear and tear during the warranty period. These parts include: paint, wood, pellet and coal gaskets, firebricks, grates, flame guides, batteries and the discoloration of glass.
- Minor expansion, contraction, or movement of certain parts causing noise. These conditions are normal and complaints related to this noise are not covered by this warranty.
- Damages resulting from: (1) failure to install, operate, or maintain the appliance in accordance with the installation instructions, operating instructions, and listing agent identification label furnished with the appliance; (2) failure to install the appliance in accordance with local building codes; (3) shipping or improper handling; (4) improper operation, abuse, misuse, continued operation with damaged, corroded or failed components, accident, or improperly/incorrectly performed repairs; (5) environmental conditions, inadequate ventilation, negative pressure, or drafting caused by tightly sealed constructions, insufficient make-up air supply, or handling devices such as exhaust fans or forced air furnaces or other such causes; (6) use of fuels other than those specified in the operating instructions; (7) installation or use of components not supplied with the appliance or any other components not expressly authorized and approved by HHT; (8) modification of the appliance not expressly authorized and approved by HHT in writing; and/or (9) interruptions or fluctuations of electrical power supply to the appliance.
- Non-HHT venting components, hearth components or other accessories used in conjunction with the appliance.
- Any part of a pre-existing fireplace system in which an insert or a decorative gas appliance is installed.
- HHT's obligation under this warranty does not extend to the appliance's capability to heat the desired space. Information is provided to assist the consumer and the dealer in selecting the proper appliance for the application. Consideration must be given to appliance location and configuration, environmental conditions, insulation and air tightness of the structure.

### **This warranty is void if:**

- The appliance has been over-fired or operated in atmospheres contaminated by chlorine, fluorine, or other damaging chemicals. Over-firing can be identified by, but not limited to, warped plates or tubes, rust colored cast iron, bubbling, cracking and discoloration of steel or enamel finishes.
- The appliance is subjected to prolonged periods of dampness or condensation.
- There is any damage to the appliance or other components due to water or weather damage which is the result of, but not limited to, improper chimney or venting installation.

### **LIMITATIONS OF LIABILITY:**

- The owner's exclusive remedy and HHT's sole obligation under this warranty, under any other warranty, express or implied, or in contract, tort or otherwise, shall be limited to replacement, repair, or refund, as specified above. In no event will HHT be liable for any incidental or consequential damages caused by defects in the appliance. Some states do not allow exclusions or limitation of incidental or consequential damages, so these limitations may not apply to you. This warranty gives you specific rights; you may also have other rights, which vary from state to state. EXCEPT TO THE EXTENT PROVIDED BY LAW, HHT MAKES NO EXPRESS WARRANTIES OTHER THAN THE WARRANTY SPECIFIED HEREIN. THE DURATION OF ANY IMPLIED WARRANTY IS LIMITED TO DURATION OF THE EXPRESSED WARRANTY SPECIFIED ABOVE.

## 2 Product Specific Information

### A. Appliance Certification

**MODEL:** RED40, RED40ST  
**LABORATORY:** Underwriters Laboratories, Inc. (UL)  
**TYPE:** Direct Vent Heater  
**STANDARD:** ANSI Z21.88b-2008 CSA 2.33a-2008  
**Vented Gas Fireplace Heaters**

- This product is listed to ANSI standards for “Vented Gas Fireplace Heaters” and applicable sections of “Gas Burning Heating Appliances for Manufactured Homes and Recreational Vehicles”, and “Gas Fired Appliances for Use at High Altitudes”.

**NOTICE:** This installation must conform with local codes. In the absence of local codes you must comply with the National Fuel Gas Code, ANSI Z223.1-latest edition in the U.S.A. and the CAN/CGA B149 Installation Codes in Canada.

**NOT INTENDED FOR USE AS A PRIMARY HEAT SOURCE.**  
 This appliance is tested and approved as either supplemental room heat or as a decorative appliance. It should not be factored as primary heat in residential heating calculations.



Installation and service of this appliance should be performed by qualified personnel. Hearth & Home Technologies suggests NFI certified or factory trained professionals, or technicians supervised by an NFI certified professional ([www.nficertified.org](http://www.nficertified.org)).

### B. Glass Specifications

This appliance is equipped with 5 mm ceramic glass. Replace glass only with 5 mm ceramic glass. Please contact your dealer for replacement glass.

### C. BTU Specifications

Models (U.S. or Canada)		Maximum Input BTU/h	Minimum Input BTU/h	Orifice Size (DMS)
RED40 RED40ST (NG)	US (0-2000 FT)	34,000	24,000	#34
	CANADA (2000-4500 FT)	29,500	22,000	#36
RED40 RED40ST (LP)	US (0-2000 FT)	34,000	25,000	#50
	CANADA (2000-4500 FT)	31,500	23,000	#51

# 3 Important Safety and Operating Information

## → A. Appliance Safety

**WARNING! DO NOT operate fireplace before reading and understanding operating instructions. Failure to operate fireplace according to operating instructions could cause fire or injury.**

### **WARNING**



**HOT GLASS WILL CAUSE BURNS. DO NOT TOUCH GLASS UNTIL COOLED. NEVER ALLOW CHILDREN TO TOUCH GLASS.**

- Keep children away.
- CAREFULLY SUPERVISE children in same room as fireplace.
- Alert children and adults to hazards of high temperatures.

**High temperatures may ignite clothing or other flammable materials.**

- Clothing, furniture, draperies, and other flammable materials must not be placed on or near the appliance.

**A barrier designed to reduce the risk of burns from the hot viewing glass is provided with this appliance and shall be installed. DO NOT operate the appliance with the barrier removed. If the barrier becomes damaged, the barrier shall be replaced with the manufacturer's barrier for this appliance.**

Contact your dealer or Hearth & Home Technologies if the barrier is not present or help is needed to properly install one.

Young children should be carefully supervised when they are in the same room as the appliance. Toddlers, young children and others may be susceptible to accidental contact burns.

- A physical barrier is recommended if there are at risk individuals in the house.
- To restrict access to a fireplace or stove, install an adjustable safety gate to keep toddlers, young children and other at risk individuals out of the room and away from hot surfaces.
- Install a switch lock or a wall/remote control with child protection lockout feature.
- Keep remote controls out of reach of children.
- Never leave children alone near a hot fireplace, whether operating or cooling down.
- Teach children to NEVER touch the fireplace.

- Consider not using the fireplace when children will be present.

Contact your dealer for more information, or visit: [www.hpba.org/safety-information](http://www.hpba.org/safety-information).

To prevent unintended operation when not using your fireplace for an extended period of time (summer months, vacations, trips, etc):

- Remove batteries from remote controls.
- Turn off wall controls.
- Unplug 3 volt adapter plug.

## Clear Space

**WARNING! DO NOT place combustible objects in front of the fireplace or block louvers. High temperatures may start a fire. See Figure 3.1.**

Avoid placing candles and other heat-sensitive objects on mantel or hearth. Heat may damage these objects.

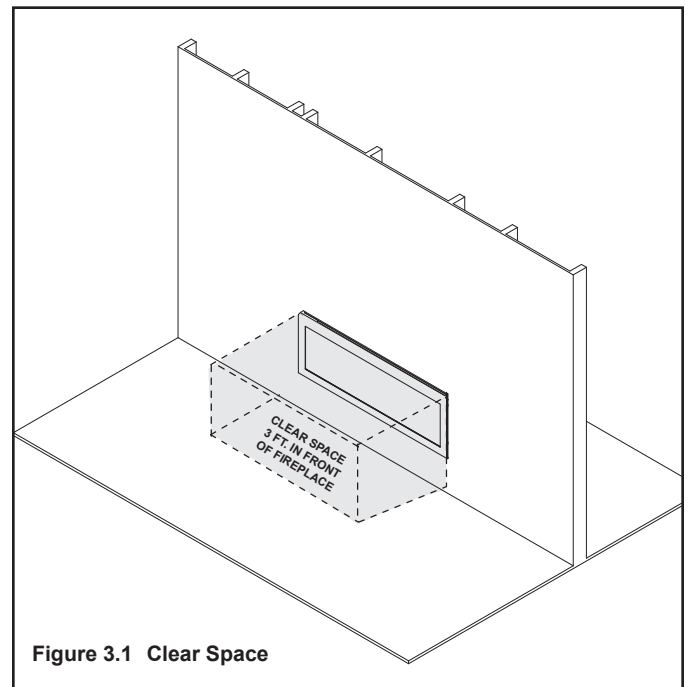

Figure 3.1 Clear Space

## Over Firing

The appliance is considered to be over firing if the flames are contacting the top of the firebox. Call a qualified service technician to service the appliance.

## B. General Operating Parts

Figure 3.2 references the general operating parts of the appliance and the section of this manual in which they are discussed.

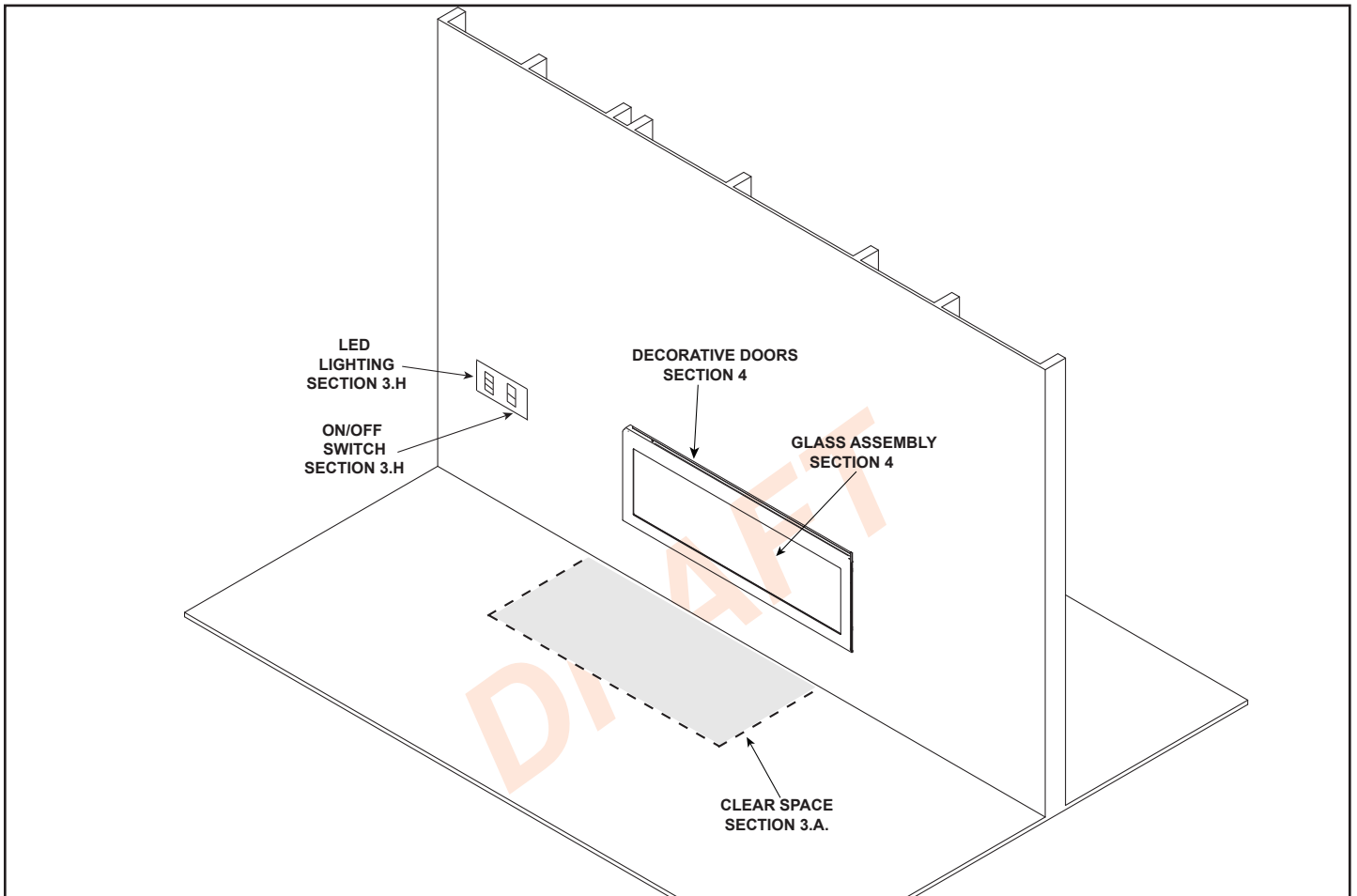

Figure 3.2 General Operating Parts

## C. Fuel Specifications

**WARNING! Risk of Fire or Explosion!** Appliance must be set up for compatible gas type!

- This appliance is designed to operate on either natural gas or propane. Make sure the appliance is compatible with gas type selected for installation site.
- Conversions must be made by a qualified service technician using Hearth & Home Technologies specified and approved parts.

## D. Before Lighting Appliance

Before operating this fireplace for the first time, **have a qualified service technician:**

- Verify all shipping materials have been removed from inside and/or underneath the firebox.
- Review proper placement of logs, ember material and/or other decorative materials.
- Check the wiring.
- Check the air shutter adjustment.
- Ensure that there are no gas leaks.
- Ensure that the glass is sealed and in the proper position and that the integral barrier is in place.

**WARNING! Risk of Fire or Asphyxiation! DO NOT operate fireplace with fixed glass assembly removed.**



## E. Lighting Instructions (IPI)

### FOR YOUR SAFETY READ BEFORE LIGHTING

**WARNING:** If you do not follow these instructions exactly, a fire or explosion may result causing property damage, personal injury or loss of life.

- A.** This appliance is equipped with an intermittent pilot ignition (IPI) device which automatically lights the burner. **DO NOT** try to light the burner by hand.
- Immediately call your gas supplier from a neighbor's phone. Follow the gas supplier's instructions.
  - If you cannot reach your gas supplier, call the fire department.

- B. BEFORE LIGHTING,** smell all around the appliance area for gas. Be sure to smell next to the floor because some gas is heavier than air and will settle on the floor.
- C. DO NOT** use this appliance if any part has been under water. Immediately call a qualified service technician to inspect the appliance and to replace any part of the control system and any gas control which has been under water.

#### WHAT TO DO IF YOU SMELL GAS

- **DO NOT** try to light any appliance.
- **DO NOT** touch any electric switch; do not use any phone in your building.

### WARNING:

**DO NOT CONNECT LINE VOLTAGE (110/120 VAC OR 220/240 VAC) TO THE CONTROL VALVE.**

Improper installation, adjustment, alteration, service or maintenance can cause injury or property damage. Refer to the owner's information manual provided with this appliance.

This appliance needs fresh air for safe operation and must be installed so there are provisions for adequate combustion and ventilation air.

If not installed, operated, and maintained in accordance with the manufacturer's instructions, this product could expose you to substances in fuel or fuel combustion which are known to the State of California to cause cancer, birth defects, or other reproductive harm.

Keep burner and control compartment clean. See installation and operating instructions accompanying appliance.

For additional information on operating your  
Hearth & Home Technologies fireplace, please refer to [www.fireplaces.com](http://www.fireplaces.com).

### CAUTION:

Hot while in operation. **DO NOT** touch. Keep children, clothing, furniture, gasoline and other liquids having flammable vapors away.

**DO NOT** operate the appliance with fixed glass assembly removed, cracked or broken. Replacement of the fixed glass assembly should be done by a licensed or qualified service person.

### NOT FOR USE WITH SOLID FUEL

For use with natural gas and propane. A conversion kit, as supplied by the manufacturer, shall be used to convert this appliance to the alternate fuel.

**Also Certified for Installation in a Bedroom or a Bedsitting Room.**

For assistance or additional information, consult a qualified installer, service agency or the gas supplier.

### LIGHTING INSTRUCTIONS (IPI)

1. This appliance is equipped with an ignition device which automatically lights the burner. **DO NOT** try to light the burner by hand.

**GAS  
VALVE**

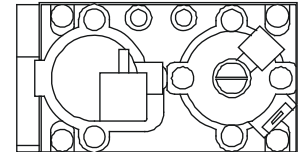

2. Wait five (5) minutes to clear out any gas. Then smell for gas, including near the floor. If you smell gas, **STOP!** Follow "B" in the Safety Information located on the left side of this label. If you do not smell gas, go to next step.

3. To light the burner:

Equipped with wall switch: Turn ON/OFF switch to ON.

Equipped with remote or wall control: Press ON or FLAME button.

Equipped with thermostat: Set temperature to desired setting.

4. If the appliance does not light after three tries, call your service technician or gas supplier.

### TO TURN OFF GAS TO APPLIANCE

1. Equipped with wall switch: Turn ON/OFF switch to OFF.

Equipped with remote or wall control: Press OFF button.

Equipped with thermostat: Set temperature to lowest setting.

2. Service technician should turn off electric power to the control when performing service.

593-913G

Final inspection by \_\_\_\_\_

## F. Appliance Break-In

### Initial Break-in Procedure

- The fireplace should be run three to four hours continuously on high.
- Turn the fireplace off and allow it to completely cool.
- Remove fixed glass assembly. See Section 4.
- Clean fixed glass assembly. See Section 4.
- Replace the fixed glass assembly and run continuously on high an additional 12 hours.

This cures the materials used to manufacture the fireplace.

**NOTICE! Open windows for air circulation during fireplace break-in.**

- Some people may be sensitive to smoke and odors.
- Smoke detectors may activate.

## G. Heat Management

### Burn Rate

The RED40 and RED40ST models have a variable burn rate which is controlled by the HI/LO knob on the gas valve. Therefore the flame height is adjustable. The HI/LO knob is shown in Figure 3.3. It is located in the control cavity of the appliance.

The Hi/Lo knob may be adjusted as desired by turning counterclockwise to the high position and by turning clockwise to the Lo position. Call a qualified service technician to make the adjustment as access to the valve cavity may be limited after the appliance is installed.

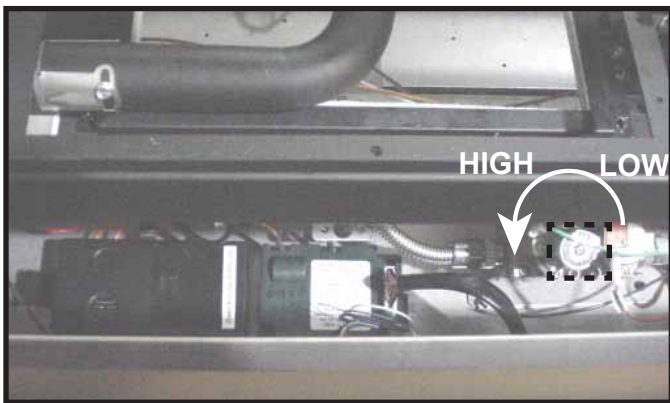

Figure 3.3. Location of Hi/Lo Knob Inside Control Cavity

## H. Detailed Component Operating Instructions

### IntelliFire™ Ignition System

Intellifire™ is an intermittent pilot ignition, which is an electronic system. The term Intermittent is used because the pilot burner flame is only present when the main burner is operating. When the main burner is off, the pilot is also off.

### Appliance ON/OFF

If an optional remote control or wall control is installed, it should be used to control the ON/OFF function of the appliance. Follow instructions included with the installed control.

### LED Lighting

The ON/OFF function for the LED lighting option is controlled by the three-position wall switch. The three-position wall switch is capable of producing seven different colors of LED lights. The colors are produced by changing the position of one, two, or all three switch positions at a time. The colors that can be produced are: green, red, blue, white/clear, yellow, purple, and light blue.

### Active Convection Technology

The fireplace appliance has been provided with an active convection blower. The blower is required to keep lower control chamber component temperatures at an ideal operating temperature. The blower also provides for more efficient use of appliance heat by assisting the convection air around the firebox and back into the room. A four inch flexible duct kit has been provided with the appliance. One end of the flex duct will connect to the fan bracket assembly located in the lower control chamber. The other end will terminate to an interior wall of the house attached to the intake grille panel provided with the appliance.

**Note:** The blower is essential for keeping components and the appliance environment in safe operating temperatures.

# 4 Maintenance and Service

Any safety screen or guard removed for servicing must be replaced prior to operating the fireplace.

→ When properly maintained, your fireplace will give you many years of trouble-free service. **Contact your dealer** to answer questions regarding proper operation, troubleshooting and service for your appliance. Visit [www.heatnglo.com](http://www.heatnglo.com) to locate a dealer. We recommend annual service by a qualified service technician.

## A. Maintenance: Frequency and Tasks

The matrix below is an overview of maintenance tasks to be performed on the appliance. Sections B and C give details and instructions needed to assist the appropriate person in performing the tasks.

Task	Frequency	To be completed by
Glass Cleaning	Seasonally	Homeowner
Doors/Fronts/Surrounds	Annually	
Remote Control	Seasonally	
Venting	Seasonally	
Gasket Seal and Glass Inspection	Annually	Qualified Service Technician
Log Inspection	Annually	
Firebox Inspection	Annually	
Control Compartment & Firebox Top	Annually	
Burner Ignition & Operation	Annually	

## B. Maintenance Tasks-Homeowner

Installation and repair should be done by a qualified service technician only. The fireplace should be inspected before use and at least annually by a professional service person.

The following tasks may be performed annually by the homeowner. If you are uncomfortable performing any of the listed tasks, please call your dealer for a service appointment.

More frequent cleaning may be required due to lint from carpeting or other factors. Control compartment, burner and circulating air passageway of the fireplace must be kept clean.

**CAUTION! Risk of Burns!** The fireplace should be turned off and cooled before servicing.

## Glass Cleaning

**Frequency:** Seasonally

**By:** Homeowner

**Tools Needed:** Protective gloves, glass cleaner, drop cloth and a stable work surface.

**WARNING! Handle fixed glass assembly with care.** Glass is breakable. Inspect the gasket to ensure it is undamaged and inspect the glass for cracks, chips or scratches.

- Avoid striking, scratching or slamming glass
  - Avoid abrasive cleaners
  - **DO NOT** clean glass while it is hot
  - Replace as a complete assembly.
- Prepare a work area large enough to accommodate fixed glass assembly and door frame by placing a drop cloth on a flat, stable surface.

**Note:** Fixed glass assembly and gasketing may have residue that can stain carpeting or floor surfaces.

1. Remove the decorative front from fireplace and set aside on work surface.
2. Locate the two spring latches that are on the lower left and right of the fireplace.
3. Use both index fingers to release spring latches. See Figure 4.1.
4. Allow glass to tilt forward. Grasp glass on the upper return lip of glass frame and tilt glass “out” and “down”. Lower gently to rest on side supports. See Figure 4.1. Allow top of glass assembly to tilt forward. Lift glass assembly “up” and “out”.

## Replacing Fixed Glass Assembly

1. Locate glide tabs on lower left and right corners.
2. Place glass bottom resting on right and left support. Tilt top of glass assembly toward fireplace.
3. Allow of the gasketing of the glass assembly to touch the face of the fireplace. Lift the glass “up” and “in” to upper glass clip flanges.
4. Hold bottom of the glass as you allow the glass assembly to seat over the two lower glass clips. See Figure 4.1.
5. Assure proper left and right placement of glass and engage both lower spring latches.

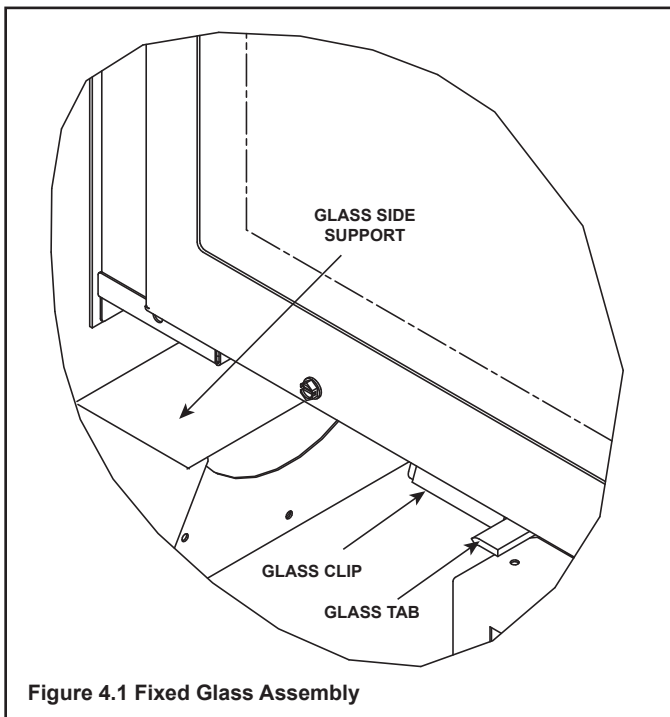

Figure 4.1 Fixed Glass Assembly

Clean glass with a non-abrasive commercially available cleaner.

- Light deposits: Use a soft cloth with soap and water
- Heavy deposits: Use commercial fireplace glass cleaner (consult with your dealer)
- Carefully set fixed glass assembly in place on fireplace. Hold glass in place with one hand and secure glass latches with the other hand.
- Reinstall decorative front.

## Doors, Surrounds, Fronts

**Frequency:** Annually

**By:** Homeowner

**Tools needed:** Protective gloves, stable work surface

- Assess condition of screen and replace as necessary.
- Inspect for scratches, dents or other damage and repair as necessary.
- Check that louvers are not blocked.
- Vacuum and dust surfaces.

## Remote Control

**Frequency:** Seasonally

**By:** Homeowner

**Tools needed:** Replacement batteries and remote control instructions.

- Locate remote control transmitter and receiver.
- Verify operation of remote. Refer to remote control operation instructions for proper calibration and setup procedure.
- Place batteries as needed in remote transmitters and battery-powered receivers.
- Place remote control out of reach of children.

If not using your fireplace for an extended period of time (summer months, vacations/trips, etc), to prevent unintended operation:

- Remove batteries from remote controls.
- Unplug 3 volt adapter plug on IPI models.
- Verify that the sensor rod does not contact the burner.

## Venting

**Frequency:** Seasonally

**By:** Homeowner

**Tools needed:** Protective gloves and safety glasses.

- Inspect venting and termination cap for blockage or obstruction such plants, bird nests, leaves, snow, debris, etc.
- Verify termination cap clearance to subsequent construction (building additions, decks, fences, or sheds).
- Inspect for corrosion or separation.
- Verify weather stripping, sealing and flashing remains intact.
- Inspect draft shield to verify it is not damaged or missing.

## C. Maintenance Tasks-Qualified Service Technician

The following tasks must be performed by a qualified service technician.

### Gasket Seal and Glass Assembly Inspection

**Frequency:** Annually

**By:** Qualified Service Technician

**Tools needed:** Protective gloves, drop cloth and a stable work surface.

- Inspect gasket seal and its condition.
- Inspect fixed glass assembly for scratches and nicks that can lead to breakage when exposed to heat.
- Confirm there is no damage to glass or glass frame. Replace as necessary.
- Verify that fixed glass assembly is properly retained and attachment components are intact and not damaged. Replace as necessary.

### Firebox

**Frequency:** Annually

**By:** Qualified Service Technician

**Tools needed:** Protective gloves, sandpaper, steel wool, cloths, mineral spirits, primer and touch-up paint.

- Inspect for paint condition, warped surfaces, corrosion or perforation. Sand and repaint as necessary.
- Replace fireplace if firebox has been perforated.

### Control Compartment and Firebox Top

**Frequency:** Annually

**By:** Qualified Service Technician

**Tools needed:** Protective gloves, vacuum cleaner, dust cloths

- Vacuum and wipe out dust, cobwebs, debris or pet hair. Use caution when cleaning these areas. Screw tips that have penetrated the sheet metal are sharp and should be avoided.
- Remove all foreign objects.
- Verify unobstructed air circulation.

## Burner Ignition and Operation

**Frequency:** Annually

**By:** Qualified Service Technician

**Tools needed:** Protective gloves, vacuum cleaner, whisk broom, flashlight, voltmeter, indexed drill bit set, and a manometer.

- Verify burner is properly secured and aligned with pilot or igniter.
- Clean off burner top, inspect for plugged ports, corrosion or deterioration. Replace burner if necessary.
- Inspect for lifting or other flame problems.
- Verify air shutter setting is correct. See Installation Manual for required air shutter setting. Verify air shutter is clear of dust and debris.
- Inspect orifice for soot, dirt and corrosion. Verify orifice size is correct. See Service Parts List for proper orifice sizing.
- Verify manifold and inlet pressures. Adjust regulator as required.
- Inspect pilot flame pattern and strength. See Figure 4.2 for proper pilot flame pattern. Clean or replace orifice spud as necessary.
- Inspect IPI flame sensing rod for soot, corrosion and deterioration. Polish with fine steel wool or replace as required.
- Verify IPI millivolt output. Replace as necessary.
- Verify that there is not a short in flame sense circuit by checking continuity between pilot hood and flame sensing rod. Replace pilot as necessary.



Figure 4.2 IPI Pilot Flame Patterns

# 5 Troubleshooting and Frequently Asked Questions

## A. Frequently Asked Questions

ISSUE	SOLUTIONS
Condensation on the glass	This is a result of gas combustion and temperature variations. As the fireplace warms, this condensation will disappear.
Blue flames	This is a result of normal operation and the flames will begin to yellow as the fireplace is allowed to burn for 20 to 40 minutes.
Odor from fireplace	When first operated, this fireplace may release an odor for the first several hours. This is caused by the curing of materials from manufacturing. Odor may also be released from finishing materials and adhesives used near the fireplace. These circumstances may require additional curing related to the installation environment.
Film on the glass	This is a normal result of the curing process of the paint. Glass should be cleaned within 3 to 4 hours of initial burning. A non-abrasive cleaner such as gas appliance glass cleaner may be necessary. See your dealer.
Metallic noise	Noise is caused by metal expanding and contracting as it heats up and cools down, similar to the sound produced by a furnace or heating duct. This noise does not affect the operation or longevity of the fireplace.
Rock noise	There may be some "cracking" noise coming from the fireplace during the first few heating and cooling cycles. This noise is associated with settling rock and some minor cracking of larger pieces of rock. This will lessen over time as the glass rock is conditioned to the heating and cooling temperature changes.
Rocks falling through basepan	It is expected that a few small pieces of rock may fall through the basepan and come to rest on the fireplace bottom. This has no affect on fireplace performance.
Wall above appliance feels hot to the touch.	No action necessary. This appliance ships with a non-combustible material attached. Specifications of the attached non-combustible material are listed in the appliance installation manual.

→ **Contact your dealer** for additional information regarding operation and troubleshooting. Visit [www.heatnglo.com](http://www.heatnglo.com) to locate a dealer.

## B. Troubleshooting

With proper installation, operation, and maintenance your gas appliance will provide years of trouble-free service. If you do experience a problem, this troubleshooting guide will assist a qualified service technician in the diagnosis of a problem and the corrective action to be taken. This troubleshooting guide can only be used by a qualified service technician. Contact your dealer to arrange a service call by a qualified service technician.

Symptom	Possible Cause	Corrective Action
1. Pilot won't light. The ignitor/module makes noise, but no spark.	a. Incorrect wiring.	Verify "S" wire (white) for sensor and "I" wire (orange) for ignitor are connected to correct terminals on module and pilot assembly.
	b. Loose connections or electrical shorts in the wiring.	Verify no loose connections or electrical shorts in wiring from module to pilot assembly. Verify connections underneath pilot assembly are tight; also verify connections are not grounding out to metal chassis, pilot burner, pilot enclosure, mesh screen if present, or any other metal object.
	c. Ignitor gap is too large.	Verify gap of igniter to right side of pilot hood. The gap should be approximately .17 in. or 1/8 in. (3 mm).
	d. Module.	Turn ON/OFF rocker switch or wall switch to OFF position. Remove ignitor wire "I" from module. Place a grounded wire about 3/16 in. (5 mm) away from "I" terminal on module. Place ON/OFF rocker switch or wall switch in ON position. If there is no spark at "I" terminal module must be replaced. If there is a spark at "I" terminal, module is fine. Inspect pilot assembly for shorted sparker wire or cracked insulator around electrode. Replace pilot if necessary.
2. Pilot won't light, there is no noise or spark.	a. No power or transformer installed incorrectly.	Verify that transformer is installed and plugged into module. Check voltage of transformer under load at spade connection on module with ON/OFF switch in ON position. Acceptable readings of a good transformer are between 3.2 and 2.8 volts AC.
	b. A shorted or loose connection in wiring configuration or wiring harness.	Remove and reinstall the wiring harness that plugs into module. Verify there is a tight fit. Verify pilot assembly wiring to module. Remove and verify continuity of each wire in wiring harness. Replace any damaged components.
	c. Improper wall switch wiring.	Verify that 110/120 VAC power is "ON" to junction box.
	d. Module not grounded.	Verify black ground wire from module wire harness is grounded to metal chassis of appliance.
	e. Module.	Turn ON/OFF rocker switch or wall switch to OFF position. Remove ignitor wire "I" from module. Place ON/OFF rocker switch or wall switch in ON position. If there is no spark at "I" terminal module must be replaced. If there is a spark at "I" terminal, module is fine. Inspect pilot assembly for shorted sparker wire or cracked insulator around electrode.
3. Pilot sparks, but Pilot will not light.	a. Gas supply.	Verify that incoming gas line ball valve is "open". Verify that inlet pressure reading is within acceptable limits.
	b. Ignitor gap is incorrect.	Verify that spark gap from ignitor to pilot hood is .17 in. or 1/8 in (3 mm).
	c. Module is not grounded.	Verify module is securely grounded to metal chassis of appliance.

## Troubleshooting - IntelliFire Ignition System - (continued)

Symptom	Possible Cause	Corrective Action
4. Pilot lights but continues to spark, and main burner will not ignite. (If the pilot continues to spark after the pilot flame has been lit, flame rectification has not occurred.)	a. A shorted or loose connection in flame sensing rod.	Verify all connections to wiring diagram in manual. Verify connections underneath pilot assembly are tight. Verify connections are not grounding out to metal chassis, pilot burner, pilot enclosure or screen if present, or any other metal object.
	b. Poor flame rectification or contaminated flame sensing rod.	With fixed glass assembly in place, verify that flame is engulfing flame sensing rod on left side of pilot hood. Flame sensing rod should glow shortly after ignition. Verify correct pilot orifice is installed and gas inlet is set to pressure specifications. Polish flame sensing rod with fine steel wool to remove any contaminants that may have accumulated on flame sensing rod.
	c. Module is not grounded.	Verify module is securely grounded to metal chassis of appliance. Verify that wire harness is firmly connected to the module.
	d. Damaged pilot assembly or contaminated flame sensing rod.	Verify that ceramic insulator around the flame sensing rod is not cracked, damaged, or loose. Verify connection from flame sensing rod to white sensor wire. Polish flame sensing rod with fine steel wool to remove any contaminants that may have accumulated on flame sensing rod. Verify continuity with a multimeter with ohms set at lowest range. Replace pilot if any damage is detected.
	e. Module.	Turn ON/OFF rocker switch or wall switch to OFF position. Remove ignitor wire "I" from module. Place ON/OFF rocker switch or wall switch in ON position. If there is no spark at "I" terminal module must be replaced. If there is a spark at "I" terminal, module is fine.
5. Appliance cycles on and off	a. Control chamber above temperature specifications.	A high limit switch is provided with the unit to assure lower component chamber temperatures do not exceed 150 degrees Fahrenheit. This is a safety feature for this model, but is not common. Contact your dealer for assistance.



# 6 Reference Materials

---

## A. Accessories

Install approved accessories per instructions included with accessories. Contact your dealer for a list of approved accessories.

***WARNING! Risk of Fire and Electric Shock! Use ONLY Hearth & Home Technologies-approved optional accessories with this appliance. Using non-listed accessories could result in a safety hazard and will void the warranty.***

## Remote Controls, Wall Controls and Wall Switches

After a qualified service technician has installed the remote control or wall switch, follow the instructions supplied with the control installed to operate your fireplace:

For safety:

- Install a switch lock or a wall/remote control with child protection lockout feature.
- Keep remote controls out of reach of children.

See your dealer if you have questions.

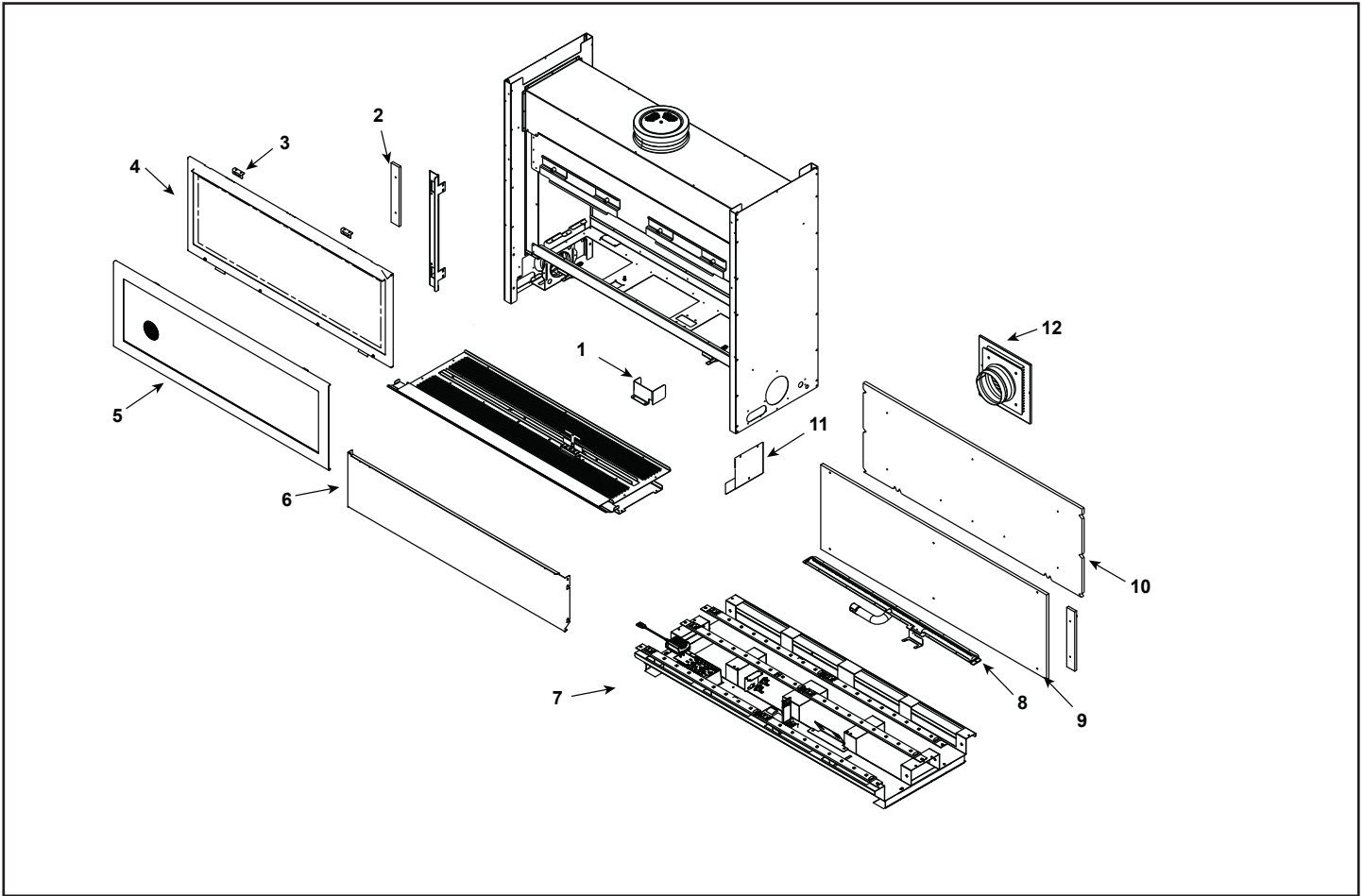

**IMPORTANT: THIS IS DATED INFORMATION.** Parts must be ordered from a dealer or distributor.

**Hearth and Home Technologies does not sell directly to consumers.** Provide model number and serial number when requesting service parts from your dealer or distributor.



**Stocked at Depot**

ITEM	DESCRIPTION	COMMENTS	PART NUMBER	
1	Pilot Shield		2155-173	
2	Non Combustible Board, Side Finish Panel	Qty 2 req	2155-460	
3	Mesh Clips	Pkg of 4	2155-184/4	Y
4	Glass Assembly		GLA-RED40	Y
5	Fire screen Door Assembly		2155-012	
	Mesh		2155-031	
6	Bottom Face Plate		2155-112	
7	Bottom Base Assembly		2155-025	
8	Burner Assembly NG/LP		2155-007	Y
9	Non Combustible Board, Outer		2155-461	
10	Non Combustible Board, Inner		2155-462	
11	Panel Cover, Side		2155-140	
12	Vent Assembly		2155-071	
	Grill Panel		2155-150	
	Glass Latch Support Assembly	Qty 2 req	2155-045	Y

Unique service parts by model on following page.

11/13

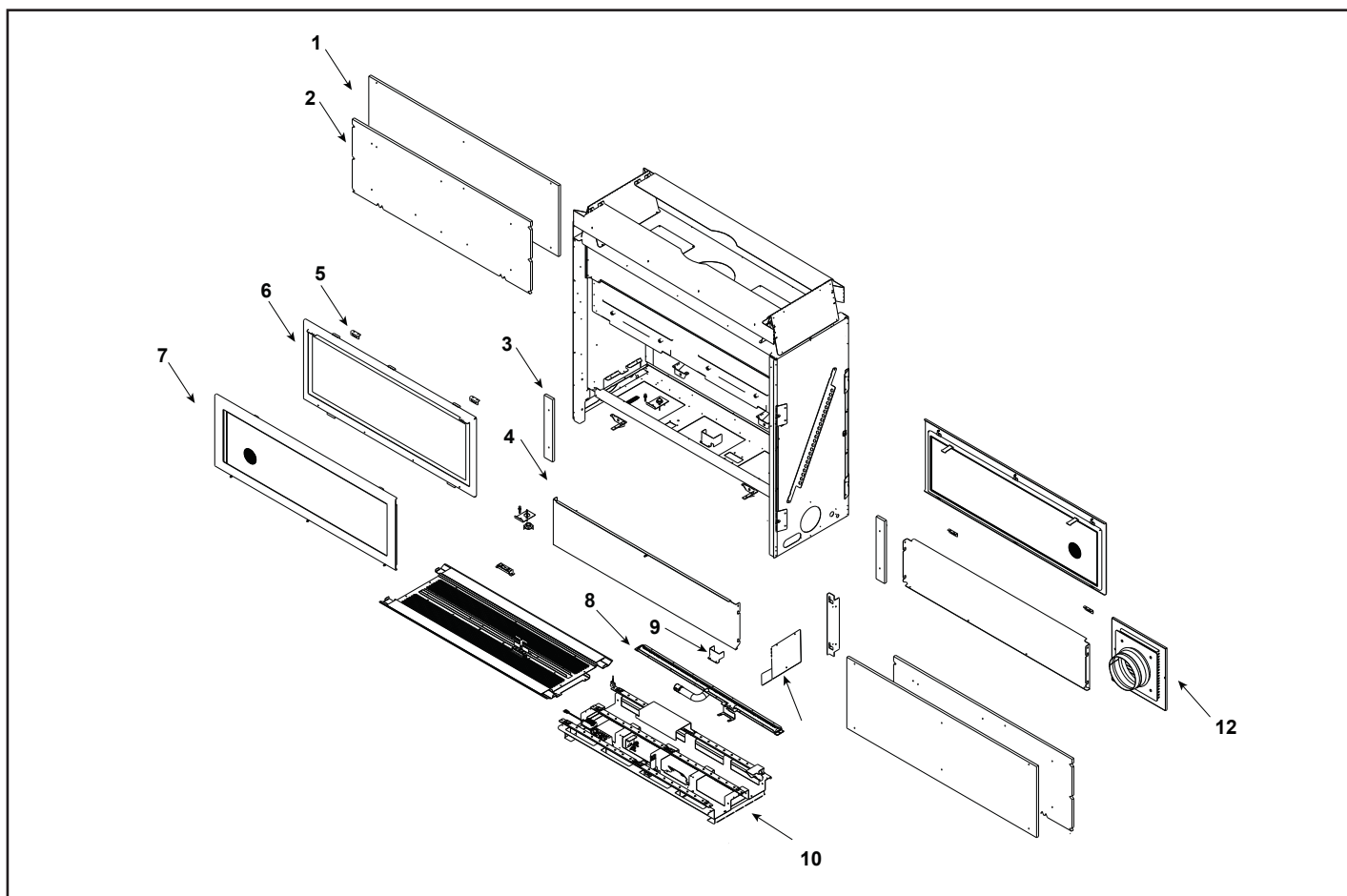

**IMPORTANT: THIS IS DATED INFORMATION.** Parts must be ordered from a dealer or distributor. **Hearth and Home Technologies does not sell directly to consumers.** Provide model number and serial number when requesting service parts from your dealer or distributor.



**Stocked  
at Depot**

ITEM	DESCRIPTION	COMMENTS	PART NUMBER	
1	Non Combustible Board, Outer	Qty 2 req	2155-461	
2	Non Combustible Board, Inner	Qty 2 req	2155-462	
3	Non Combustible Board, Side Panel Finish	Qty 4 req	2155-460	
4	Bottom Face Plate	Qty 2 req	2155-112	
5	Mesh Clips	Pkg of 4	2155-184/4	Y
6	Glass Assembly	Qty 2 req	GLA-RED40	Y
7	Fire screen Door Assembly	Qty 2 req	2155-012	
	Mesh		2155-031	
8	Burner Assembly NG		2155-007	Y
9	Pilot Shield		2155-173	
10	Base Pan		2155-025	
11	Panel Cover, Side		2155-140	
12	Vent Assembly		2155-071	
	Grille Panel		2155-150	
	Glass Latch Support Assembly	Qty 4 req	2155-045	Y

Additional service part numbers on following page.

11/13

No one builds a better fire

### #13 Control Assembly

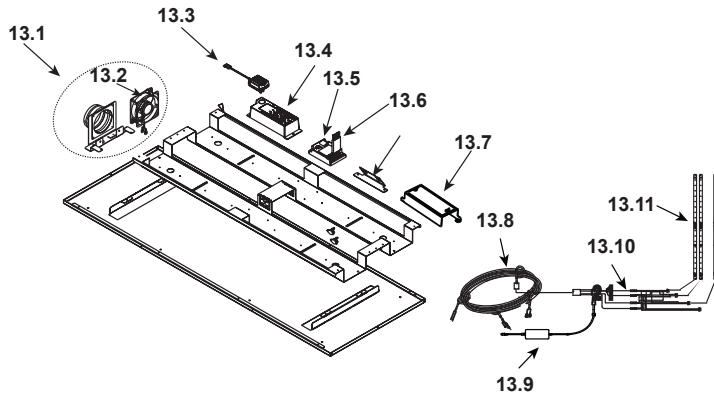

### #14 Valve Assembly

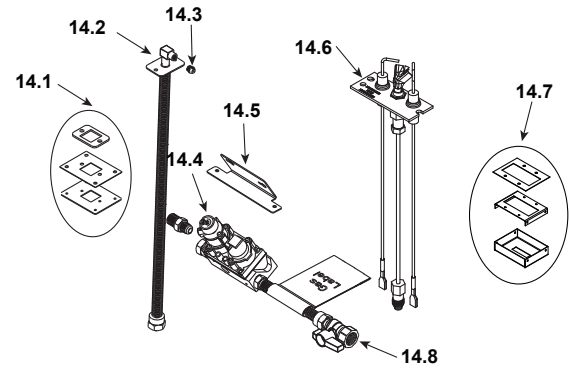

**IMPORTANT: THIS IS DATED INFORMATION.** Parts must be ordered from a dealer or distributor. **Hearth and Home Technologies does not sell directly to consumers.** Provide model number and serial number when requesting service parts from your dealer or distributor.



**Stocked at Depot**

ITEM	DESCRIPTION	COMMENTS	PART NUMBER	
13.1	Fan Assembly with Bracket		2155-070	
13.2	Blower Assembly		705-567A	Y
13.3	Transformer		593-593A	Y
13.4	Junction Box		4021-013	Y
13.5	Control Module		593-592	Y
13.6	Wire Assembly		593-590A	Y
13.7	Valve Bracket		2155-149	
13.8	Heat Shield, Module		2155-188	
13.9	LED Control Cable		2155-755	Y
13.10	LED Power Supply		2155-751	Y
13.11	LED Jumper Connections		2155-752	Y
13.12	LED Light Bar Assembly	Qty 3 req	2155-057	Y
14.1	Flex Plate/ Gasket Assembly		2155-044	
14.2	18" Flex Tube Assembly		530-302A	Y
14.3	Orifice NG (#34C)		582-834	Y
	Orifice LP (#50C)		582-850	Y
14.4	Valve NG		750-500	Y
	Valve LP		750-501	Y
14.5	Valve Bracket		2155-149	
14.6	Pilot Assembly NG		2090-012	Y
	Pilot Assembly LP		2090-013	Y
14.7	Pilot Bracket Assembly		2155-049	
14.8	Flex Ball Valve Assembly		302-320A	Y

Additional service part numbers on following page.

No one builds a better fire

**IMPORTANT: THIS IS DATED INFORMATION.** Parts must be ordered from a dealer or distributor. **Hearth and Home Technologies does not sell directly to consumers.** Provide model number and serial number when requesting service parts from your dealer or distributor.



**Stocked  
at Depot**

ITEM	DESCRIPTION	COMMENTS	PART NUMBER	
	Dual Wall Switch Plate		2155-511	
	Fiberglass Rope		060-455	
	Flexible Duct Connector 8 FT		2155-360	
	Grommet, 3-Hole		2118-420	
	High Limit Switch	Qty 2 req	514-530	Y
	High Temp Limit Switch Assembly		046-018A	Y
	Hood Clips	Pkg of 24	047-805-24	Y
	Jumper Wire 2 in 1/4 F to 1/4 F		2155-033	Y
	Jumper Wire 3/16 F to 1/4 F		2155-035	Y
	Jumper Wire 3/16 M to 1/4 F		2155-034	Y
	Pilot Bracket		2155-176	
	Pilot Support Bracket Assembly		2155-009	
	Restrictor 3"		2155-145	
	Restrictor 4"		2155-162	
	Retainer clip	Qty 9 req	2155-199	
	Touch Up Paint		TUP-GBK-12	
	Wall Switch		WSK-21-W	
	Wall Switch Wire		062-550	
	Wire Harness 20 inch Female		107-559A	Y
	Conversion Kit NG		NGK-RED40	Y
	Conversion Kit LP		LPK-RED40	Y
	Pilot Orifice NG		593-528	Y
	Pilot Orifice LP		593-527	Y
	Regulator NG		NGK-DXV	Y
	Regulator LP		LPK-DXV	Y

Unique service parts by model on following page.

No one builds a better fire

Beginning Manufacturing Date: May 2009

Ending Manufacturing Date: Active

### #15 Base Pan No Lights with Media

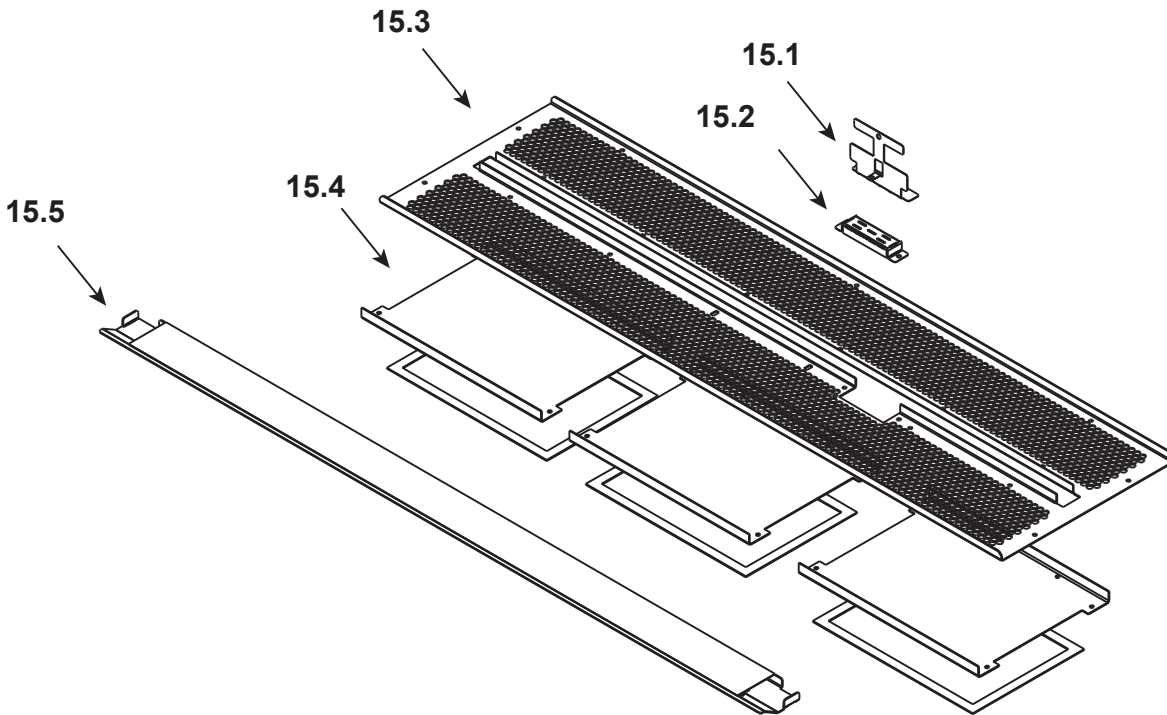

**IMPORTANT: THIS IS DATED INFORMATION.** Parts must be ordered from a dealer or distributor. **Hearth and Home Technologies does not sell directly to consumers.** Provide model number and serial number when requesting service parts from your dealer or distributor.



**Stocked at Depot**

ITEM	DESCRIPTION	COMMENTS	PART NUMBER
<b>Model No Media Option</b>			
	<b>RED40-NWN (No lights, White Rock, No Refractory)</b>		<b>RED40-NON (No lights, Onyx, No Refractory)</b>
	<b>RED40-NWG (No lights, White Rock, Granite)</b>		<b>RED40-NOG (No lights, Onyx, Granite)</b>
	<b>RED40-NWP (No lights, White Rock, Porcelain)</b>		<b>RED40-NOP (No lights, Onyx, Porcelain)</b>
15	Base Pan With Media		2155-026
15.1	Rock Placement Jig		2155-170
15.2	Pilot Cover		2155-160
15.3	Base Pan		2155-151
15.4	Bottom Plate	Qty 3 req	2155-161
15.5	Access Panel Assembly		2155-060
	Rock	Solid White	MEDIA-WHITE
		Onyx	MEDIA-ONYX
	Refractory	Granite	GR40-L
		Porcelain	POR40-L

Additional service part numbers on following page.

No one builds a better fire

Beginning Manufacturing Date: May 2009

Ending Manufacturing Date: Active

### #15 Base Pan No Lights with Media

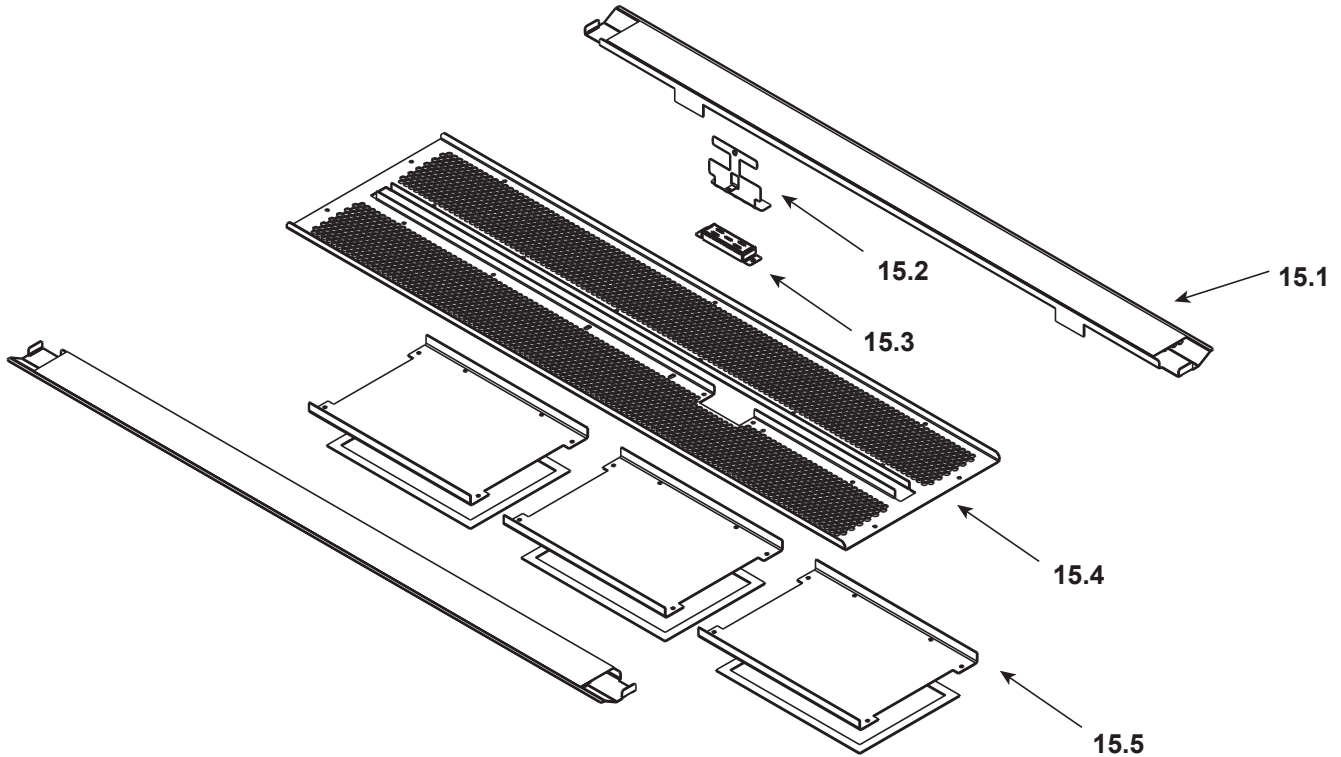

**IMPORTANT: THIS IS DATED INFORMATION.** Parts must be ordered from a dealer or distributor. **Hearth and Home Technologies does not sell directly to consumers.** Provide model number and serial number when requesting service parts from your dealer or distributor.



**Stocked  
at Depot**

ITEM	DESCRIPTION	COMMENTS	PART NUMBER
	RED40ST-NWN (No lights, White Rock, No Refractory)	RED40ST-NON (No lights, Onyx, No Refractory)	
	RED40ST-NWG (No lights, White Rock, Granite)	RED40ST-NOG (No lights, Onyx, Granite)	
	RED40ST-NWP (No lights, White Rock, Porcelain)	RED40ST-NOP (No lights, Onyx, Porcelain)	
15	Base Pan With Media		2175-026
15.1	Access Panel Assembly	Qty 2 req	2155-060
15.2	Rock Placement Jig		2155-170
15.3	Pilot Cover		2155-171
15.4	Base Pan		2155-151
15.5	Bottom Plate	Qty 3 req	2155-161
	Rock	Solid White	MEDIA-WHITE
		Onyx	MEDIA-ONYX
	Refractory	Granite	GR40ST-L
		Porcelain	POR40ST-L

Additional service part numbers on following page.

No one builds a better fire

Beginning Manufacturing Date: May 2009  
Ending Manufacturing Date: Active

### #16 Base Pan With Lights and Media

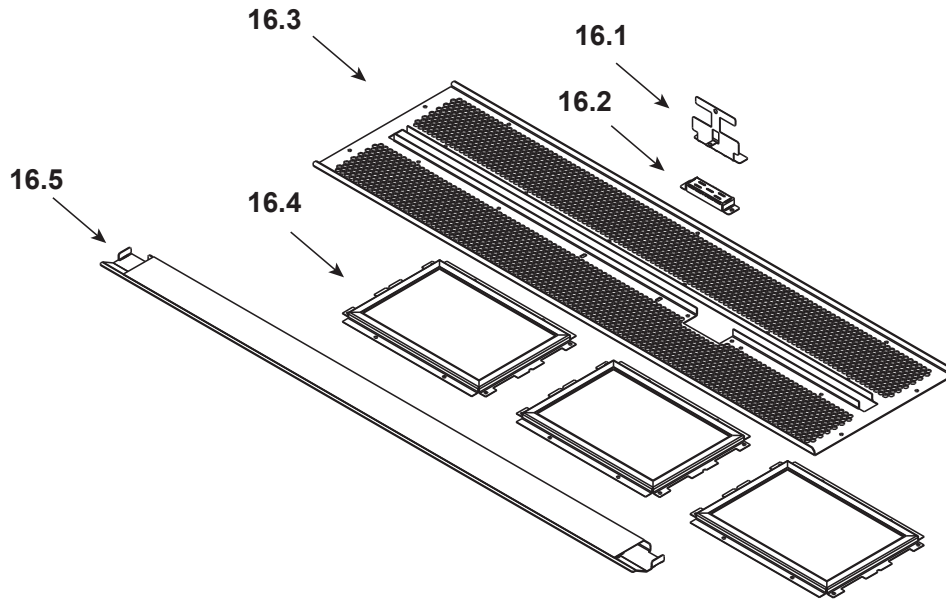

**IMPORTANT: THIS IS DATED INFORMATION.** Parts must be ordered from a dealer or distributor. **Hearth and Home Technologies does not sell directly to consumers.** Provide model number and serial number when requesting service parts from your dealer or distributor.



**Stocked at Depot**

ITEM	DESCRIPTION	COMMENTS	PART NUMBER	
<b>Model Media Option</b>				
	RED40-LRP (Lights, Red Rock, Porcelain)		RED40-LGP (Lights, Green Rock, Porcelain)	
	RED40-LRN (Lights, Red Rock, No Refractory)		RED40-LGN (Lights, Green Rock, No Refractory)	
	RED40-LRG (Lights, Red Rock, Granite)		RED40-LGG (Lights, Green Rock, Granite)	
	RED40-LCG (Lights, Clear, Granite)		RED40-LBP (Lights, Deep Blue, Porcelain)	
	RED40-LCN (Lights, Clear, No Refractory)		RED40-LBN (Lights, Deep Blue, No Refractory)	
	RED40-LCP (Lights, Clear, Porcelain)		RED40-LBG (Lights, Deep Blue, Granite)	
16	Base Pan with Media		2155-027	
16.1	Rock Placement Jig		2155-170	
16.2	Pilot Cover		2155-171	
16.3	Base Pan		2155-151	
16.4	Glass Assembly, Lights	Qty 3 req	2155-019	
16.5	Access Panel Assembly		2155-060	
	Rock	Ruby Red	MEDIA-RED	
		Clear	MEDIA-CLEAR	
		Dark Green	MEDIA-GREEN	
		Deep Blue	MEDIA-BLUE	
	Refractory	Granite	GR40-L	
		Porcelain	POR40-L	
	Convert from Porcelain or Granite to Metal Refractory	Qty 2 req	2155-232	
	On/Off Switches	<b>Lighted Units Only</b>	2155-204	<b>Y</b>

Additional service part numbers on following page.



No one builds a better fire

Beginning Manufacturing Date: May 2009

Ending Manufacturing Date: Active

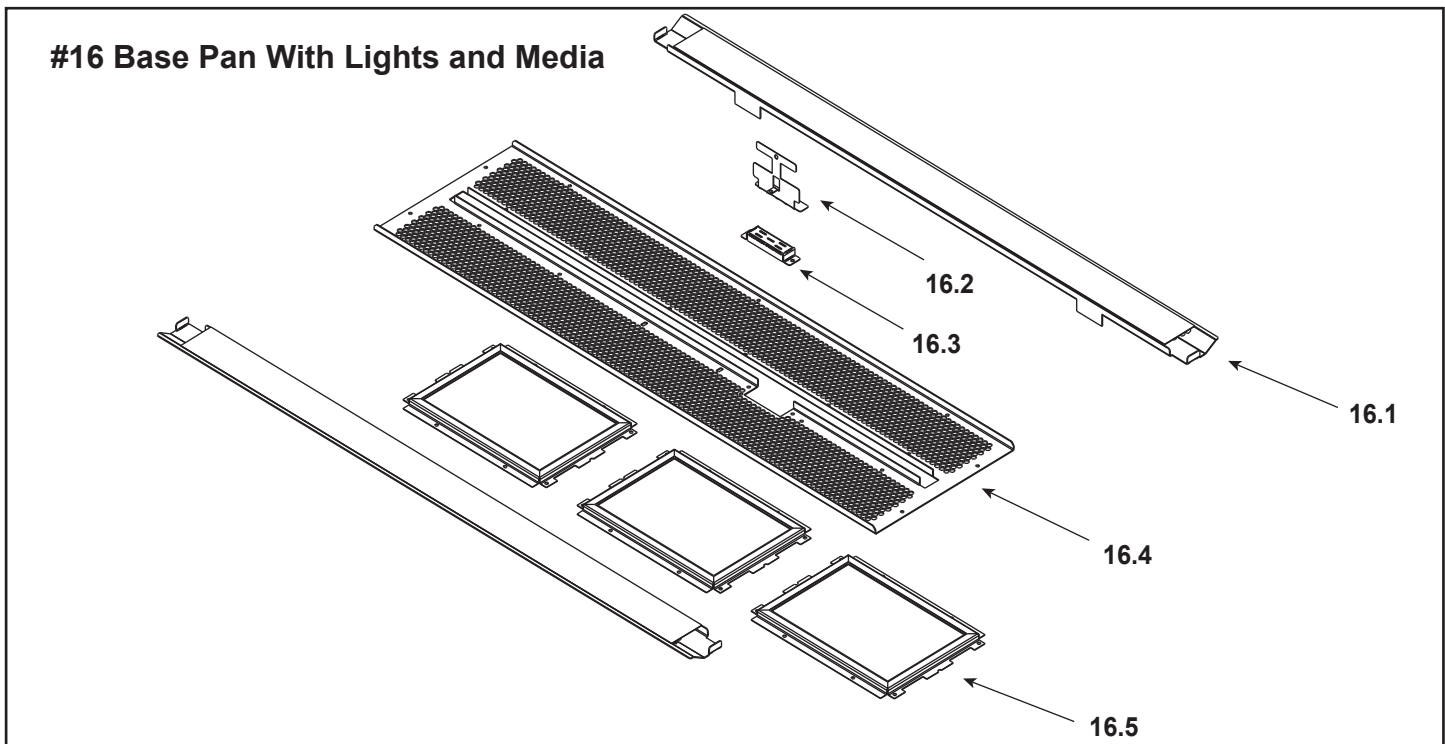

**IMPORTANT: THIS IS DATED INFORMATION.** Parts must be ordered from a dealer or distributor. **Hearth and Home Technologies does not sell directly to consumers.** Provide model number and serial number when requesting service parts from your dealer or distributor.



Stocked at Depot

ITEM	DESCRIPTION	COMMENTS	PART NUMBER	
	RED40ST-LRP (Lights, Red Rock, Porcelain)		RED40ST-LGP (Lights, Green Rock, Porcelain)	
	RED40ST-LRN (Lights, Red Rock, No Refractory)		RED40ST-LGN (Lights, Green Rock, No Refractory)	
	RED40ST-LRG (Lights, Red Rock, Granite)		RED40ST-LGG (Lights, Green Rock, Granite)	
	RED40ST-LCG (Lights, Clear, Granite)		RED40ST-LBP (Lights, Deep Blue, Porcelain)	
	RED40ST-LCN (Lights, Clear, No Refractory)		RED40ST-LBN (Lights, Deep Blue, No Refractory)	
	RED40ST-LCP (Lights, Clear, Porcelain)		RED40ST-LBG (Lights, Deep Blue, Granite)	
16	Base Pan with Media		2175-027	
16.1	Access Panel Assembly	Qty 2 req	2155-060	
16.2	Rock Placement Jig		2155-170	
16.3	Pilot Cover		2155-171	
16.4	Base Pan		2155-151	
16.5	Glass Assembly, Lights	Qty 3 req	2155-019	
	Rock	Ruby Red	MEDIA-RED	
		Clear	MEDIA-CLEAR	
		Dark Green	MEDIA-GREEN	
		Deep Blue	MEDIA-BLUE	
	Refractory	Granite	GR40ST-L	
		Porcelain	POR40ST-L	
	Convert from Porcelain or Granite to Metal Refractory	Qty 2 req	2155-232	
	3 On/Off Switch	Lighted Units Only	2155-204	Y

Additional service part numbers on following page.

No one builds a better fire

Beginning Manufacturing Date: May 2009  
Ending Manufacturing Date: Active

### #17 Base Pan No Lights or Media with Porcelain or No refractory

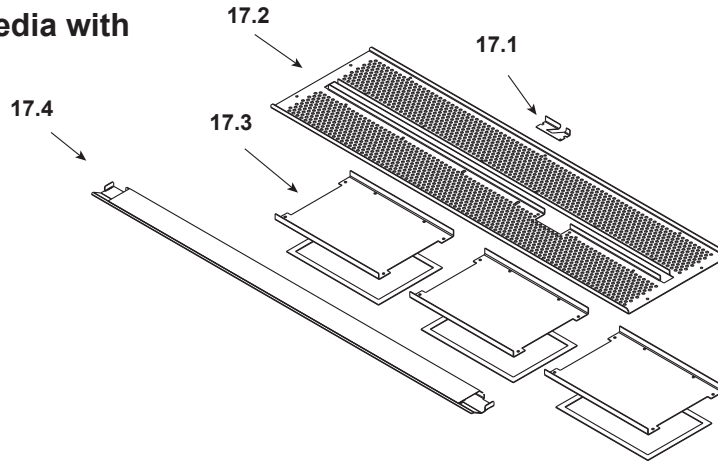

IMPORTANT: THIS IS DATED INFORMATION. Parts must be ordered from a dealer or distributor. **Hearth and Home Technologies does not sell directly to consumers.** Provide model number and serial number when requesting service parts from your dealer or distributor.



**Stocked at Depot**

ITEM	DESCRIPTION	COMMENTS	PART NUMBER
<b>RED40-NNN (No lights, No Rock, No Refractory)</b>		<b>RED40-NNP (No lights, No Rock, Porcelain)</b>	
17	Base Pan No Media Option		2155-028
17.1	Burner Insert		2155-160
17.2	Base Pan		2155-152
17.3	Bottom Plate	Qty 3 req	2155-161
17.4	Access Panel Assembly		2155-060
	Refractory	Metal	SMR-40NL
		Porcelain	POR-40F

### #18 Base Pan No Lights or Media with Granite refractory

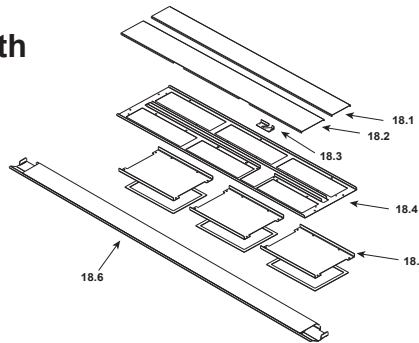

<b>RED40-NNG (No lights, No Rock, Granite)</b>			
18	Base Pan No Media Option		2155-029
18.1	Base Plate Inner	Back	2155-133
18.2	Base Plate Inner	Front	2155-132
18.3	Burner Insert		2155-160
18.4	Base Pan		2155-134
18.5	Bottom Plate	Qty 3 req	2155-161
18.6	Access Panel Assembly		2155-060
	Refractory		GR-40F

Additional service part numbers on following page.

No one builds a better fire

Beginning Manufacturing Date: May 2009

Ending Manufacturing Date: Active

### #17 Base Pan No Lights or Media with Porcelain or No refractory

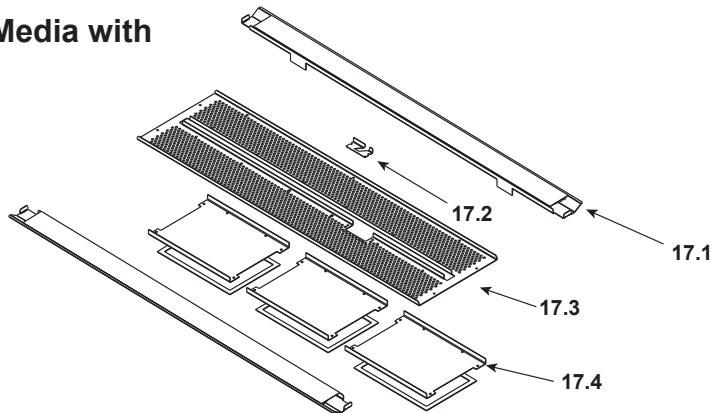

**IMPORTANT: THIS IS DATED INFORMATION.** Parts must be ordered from a dealer or distributor. **Hearth and Home Technologies does not sell directly to consumers.** Provide model number and serial number when requesting service parts from your dealer or distributor.



Stocked at Depot

ITEM	DESCRIPTION	COMMENTS	PART NUMBER	
<b>RED40ST-NNN (No lights, No Rock, No Refractory)</b>		<b>RED40ST-NNP (No lights, No Rock, Porcelain)</b>		
17	Base Pan No Media		2175-028	
17.1	Access Panel Assembly	Qty 2 req	2155-060	
17.2	Burner Insert		2155-160	
17.3	Base Pan		2155-152	
17.4	Bottom Plate	Qty 3 req	2155-161	
	Refractory	Metal	SMR-40STNL	
		Porcelain	POR-40ST-F	

### #18 Base Pan No Lights or Media with Granite refractory

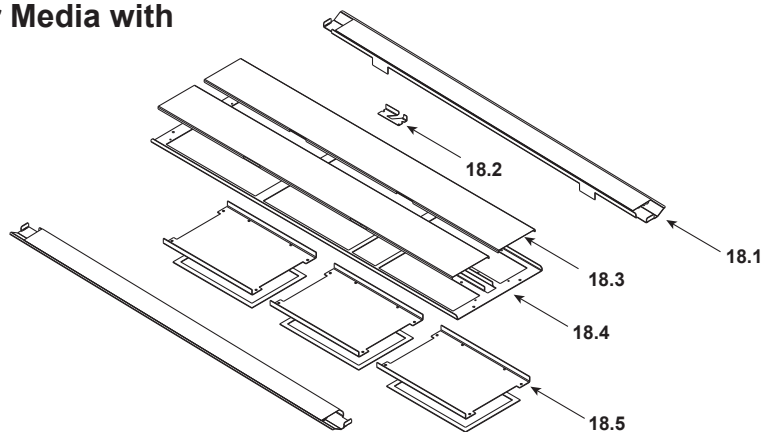

<b>RED40ST-NNG (No lights, No Rock, Granite)</b>				
18	Base Pan with Media		2175-029	
18.1	Access Panel Assembly	Qty 2 req	2155-060	
18.2	Burner Insert		2155-160	
18.3	Mesh Plate	Qty 2 req	2155-132	
18.4	Base Pan		2155-134	
18.5	Bottom Plate	Qty 2 req	2155-161	
	Refractory	Granite	GR40ST-F	

Additional service part numbers on following page.

No one builds a better fire

Beginning Manufacturing Date: May 2009  
Ending Manufacturing Date: Active

### #19 Granite -- No Media

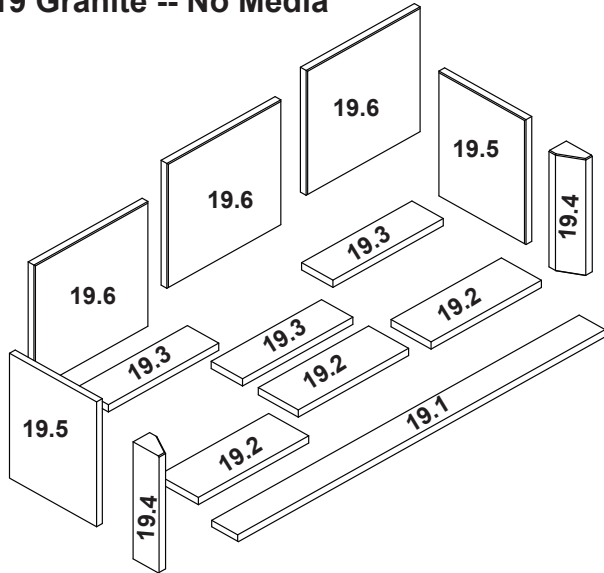

ITEM	DESCRIPTION	COMMENTS	PART NUMBER
19	Refractory Kit		GR40-F
19.1	Refractory Outer		2155-217
19.2	Refractory, Inner (Qty 3 req)		2155-215
19.3	Refractory, Inner Bttm (Qty 3 req)		2155-216
19.4	Refractory, Corner (Qty 2 req)		2155-235
19.5	Refractory, Side (Qty 2 req)		2155-210
19.6	Refractory, Back (Qty 3 req)		2155-209

### #21 Granite -- With Media

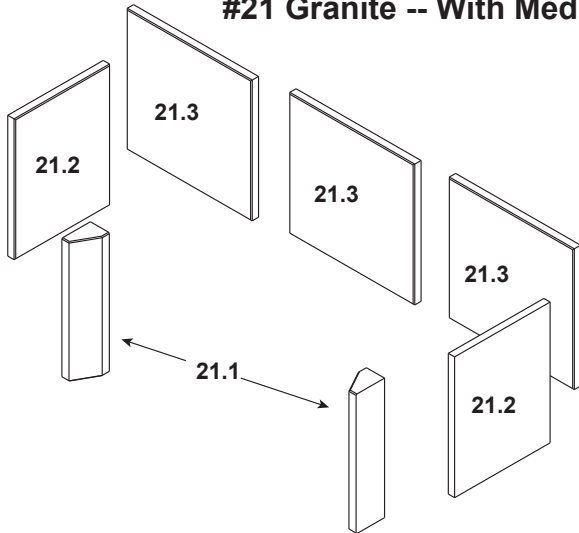

ITEM	DESCRIPTION	PART NUMBER
21	Refractory Kit	GR40-L
21.1	Refractory, Corner (Qty 2 req)	2175-225
21.2	Refractory, Side (Qty 2 req)	2155-210
21.3	Refractory, Back (Qty 3 req)	2155-209

### #20 Porcelain -- No Media

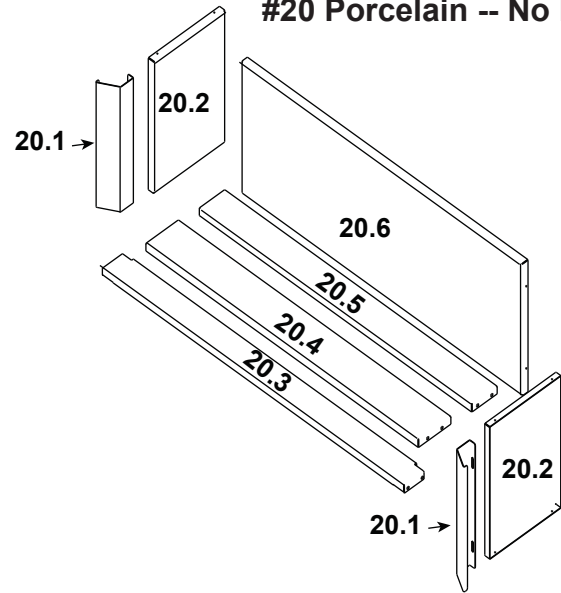

ITEM	DESCRIPTION	COMMENTS	PART NUMBER
20	Refractory Kit		POR40-F
20.1	Refractory, Corner (Qty 2 req)		2155-230
20.2	Refractory, Side (Qty 2 req)		2155-223
20.3	Refractory, Outer Bottom		2155-226
20.4	Refractory, Inner Front		2155-224
20.5	Refractory, Inner		2155-225
20.6	Refractory, Back		2155-222

### #22 Porcelain -- With Media

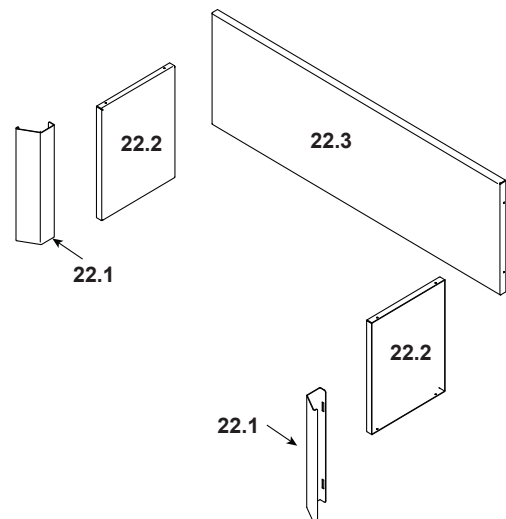

ITEM	DESCRIPTION	PART NUMBER
22	Refractory Kit	POR40-L
22.1	Refractory, Corner (Qty 2 req)	2155-219
22.2	Refractory, Side (Qty 2 req)	2155-223
22.3	Refractory, Back	2155-222

No one builds a better fire

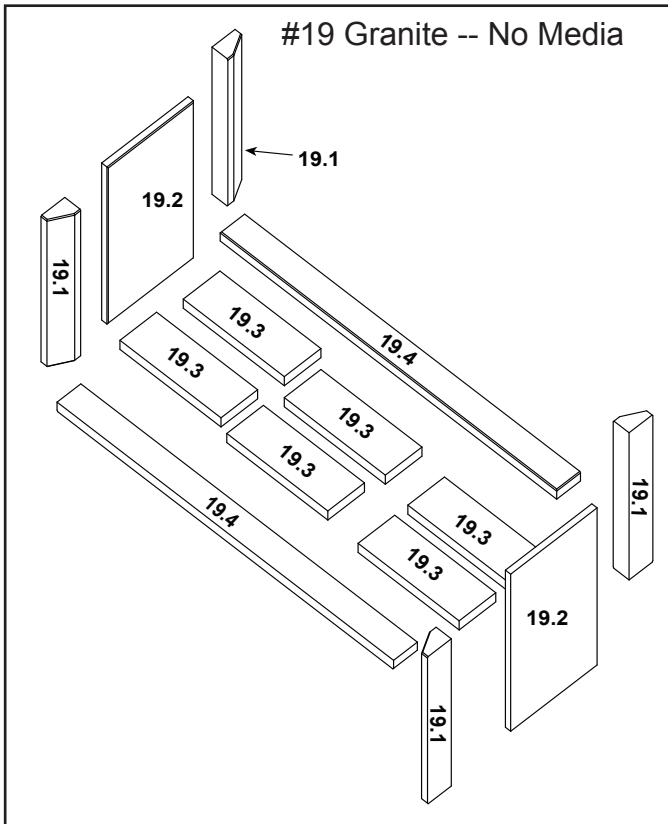

ITEM	DESCRIPTION	PART NUMBER
19	Refractory Kit	GR40ST-F
19.1	Refractory, Corner (Qty 4 req)	2155-235
19.2	Refractory Side (Qty 2 req)	2175-224
19.3	Refractory, Inner (Qty 6 req)	2155-215
19.4	Refractory, Outer (Qty 2 req)	2155-217

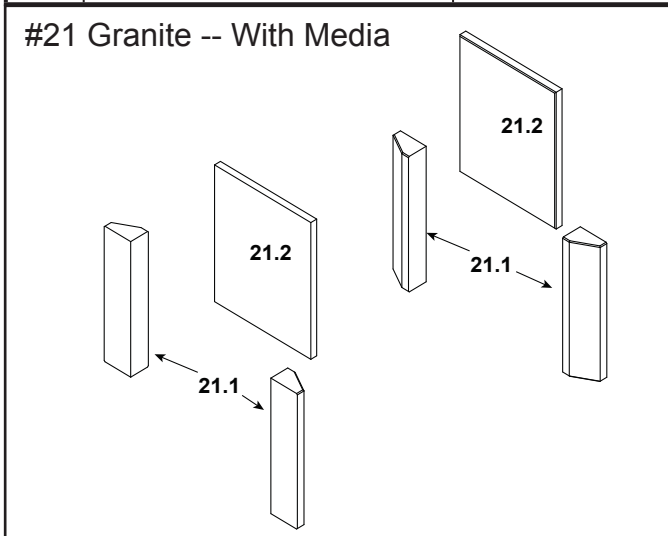

ITEM	DESCRIPTION	PART NUMBER
21	Refractory Kit	GR40ST-L
21.1	Refractory, Corner (Qty 4 req)	2175-225
21.2	Refractory, Side (Qty 2 req)	2175-224

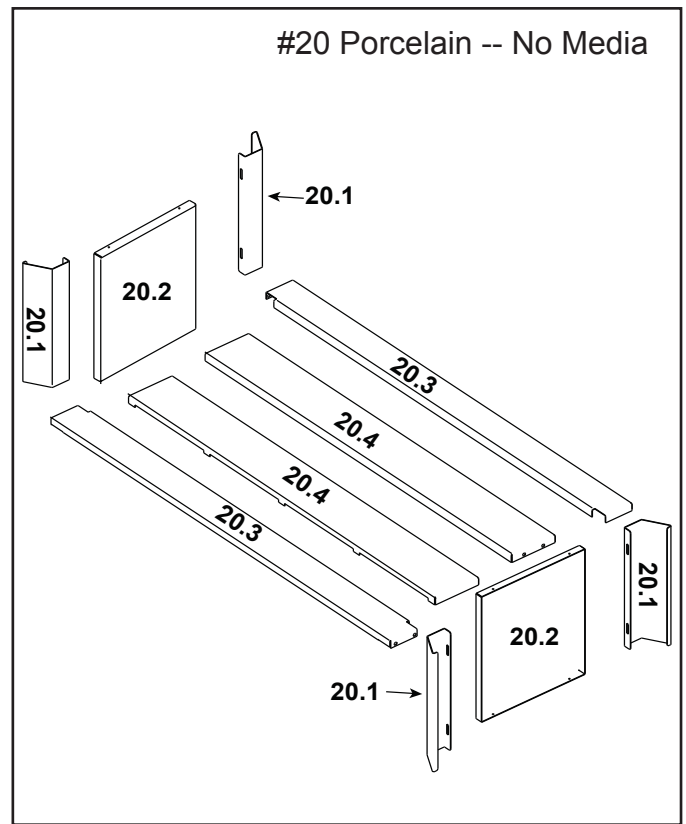

ITEM	DESCRIPTION	PART NUMBER
20	Refractory Kit	POR40ST-F
20.1	Refractory, Corner (Qty 4 req)	2155-230
20.2	Refractory, Side (Qty 2 req)	2175-223
20.3	Refractory, Outer Bttm (Qty 2 req)	2155-226
20.4	Refractory, Inner Front (Qty 2 req)	2155-224

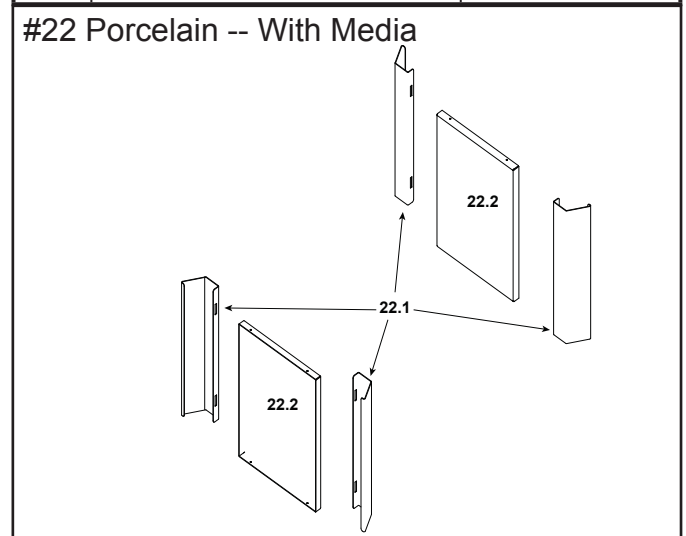

ITEM	DESCRIPTION	PART NUMBER
22	Refractory Kit	POR40ST-L
22.1	Refractory, Corner (Qty 4 req)	2155-219
22.2	Refractory, Side (Qty 2 req)	2155-223

**C. Contact Information**



No one builds a better fire

Heat & Glo, a brand of Hearth & Home Technologies  
7571 215<sup>th</sup> Street West, Lakeville, MN 55044  
[www.heatnglo.com](http://www.heatnglo.com)

Please contact your Heat & Glo dealer with any questions or concerns.  
For the location of your nearest Heat & Glo dealer,  
please visit [www.heatnglo.com](http://www.heatnglo.com).

**- NOTES -**

---

---

---

---

---

---

---



---

---

---

---

---

<b>NOTICE</b>		
	<b>DO NOT DISCARD THIS MANUAL</b>	
<ul style="list-style-type: none"> <li>• Important operating and maintenance instructions included.</li> </ul>	<ul style="list-style-type: none"> <li>• Read, understand and follow these instructions for safe installation and operation.</li> </ul>	<ul style="list-style-type: none"> <li>• Leave this manual with party responsible for use and operation.</li> </ul>

This product may be covered by one or more of the following patents: (United States) 5601073, 5613487, 5647340, 5890485, 5941237, 6006743, 6019099, 6053165, 6145502, 6374822, 6484712, 6601579, 6769426, 6863064, 7077122, 7098269, 7258116, 7470729, 8147240 or other U.S. and foreign patents pending.

2000-945B

*Printed in U.S.A. - Copyright 2013*