

**Model:**  
**GEM-42B**

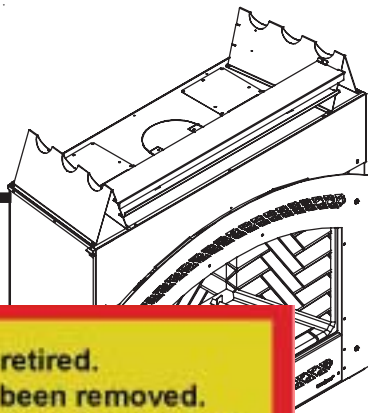

**GAS-FIRED**



**This appliance has been retired.**  
**Service parts pages within have been removed.**  
**For replacement parts, please refer to the individual service parts list located on the brand websites.**

### CAUTION



#### DO NOT DISCARD THIS MANUAL

- Important operating and maintenance instructions included.
- Read, understand and follow these instructions for safe installation and operation.
- Leave this manual with party responsible for use and operation.

**⚠ WARNING:** If the information in these instructions is not followed exactly, a fire or explosion may result causing property damage, personal injury, or death.

- Do not store or use gasoline or other flammable vapors and liquids in the vicinity of this or any other appliance.
- **What to do if you smell gas**
  - Do not try to light any appliance
  - Do not touch any electrical switch. Do not use any phone in your building.
  - Immediately call your gas supplier from a neighbor's phone. Follow the gas supplier's instructions.
  - If you cannot reach your gas supplier, call the fire department.
- Installation and service must be performed by a qualified installer, service agency, or the gas supplier.

### ⚠ WARNING



**HOT! DO NOT TOUCH.**  
**SEVERE BURNS MAY RESULT.**  
**CLOTHING IGNITION MAY RESULT.**

Glass and other surfaces are hot during operation and cool down.

- Keep children away.
- CAREFULLY SUPERVISE children in same room as appliance.
- Alert children and adults to hazards of high temperatures.
- Do NOT operate with protective barriers open or removed.
- Keep clothing, furniture, draperies and other combustibles away.

***This appliance has been supplied with an integral barrier to prevent direct contact with the fixed glass panel. Do NOT operate the appliance with the barrier removed.***

Contact your dealer or Hearth & Home Technologies if the barrier is not present or help is needed to properly install one.

In the Commonwealth of Massachusetts:

- installation must be performed by a licensed plumber or gas fitter;

See Table of Contents for location of additional Commonwealth of Massachusetts requirements.

This appliance may be installed as an OEM installation in manufactured home (USA only) or mobile home and must be installed in accordance with the manufacturer's instructions and the manufactured home construction and safety standard, *Title 24 CFR, Part 3280* or *Standard for Installation in Mobile Homes, CAN/CSA Z240MH*.

*This appliance is only for use with the type(s) of gas indicated on the rating plate.*



Installation and service of this appliance should be performed by qualified personnel. Hearth & Home Technologies suggests NFI certified or factory-trained professionals, or technicians supervised by an NFI certified professional.



Read this manual before installing or operating this appliance.  
Please retain this owner's manual for future reference.

## Congratulations

Congratulations on selecting a Heat & Glo gas appliance—an elegant and clean alternative to wood burning appliances. The Heat & Glo gas appliance you have selected is designed to provide the utmost in safety, reliability, and efficiency.

As the owner of a new appliance, you'll want to read and carefully follow all of the instructions contained in this *Owner's Manual*. Pay special attention to all Cautions and Warnings.

This *Owner's Manual* should be retained for future reference. We suggest that you keep it with your other important documents and product manuals.

The information contained in this *Owner's Manual*, unless noted otherwise, applies to all models and gas control systems.

Your new Heat & Glo gas appliance will give you years of durable use and trouble-free enjoyment. Welcome to the Heat & Glo family of appliance products!

<h3>Homeowner Reference Information</h3> <p>Model Name: _____ Date purchased/installed: _____</p> <p>Serial Number: _____ Location on appliance: _____</p> <p>Dealership purchased from: _____ Dealer Phone: _____</p> <p>Notes: _____</p> <p>_____</p>	<p><i>We recommend that you record the following pertinent information about your appliance.</i></p>
---	--

### Listing Label Information/Location

The model information regarding your specific appliance can be found on the rating plate usually located in the control area of the appliance.

Type of Gas

Gas and Electric Information

This product may be covered by one or more of the following patents: (Nos produits sont couverts par un ou plusieurs des brevets suivants): (United States) 4593510, 4688807, 4766876, 4793322, 4811534, 5000162, 5016609, 5076254, 5113843, 5191877, 5218953, 5263471, 5328356, 5341794, 5347983, 5429495, 5452708, 5542407, 5601073, 5613487, 5647340, 5688958, 5762062, 5775408, 5890485, 5931661, 5941237, 5947112, 5995575, 6006743, 6013099, 6048195, 6053165, 6145502, 6170481, 6237598, 6296474, 6374822, 6413079, 6439226, 6484712, 6543898, 6550687, 6601579, 6672860, 668830262, 671572482, 6729551, 6736133, 6748940, 6748942, D320652, D445174, D462436; (Canada) 1297749, 2195264, 2225408; or other U.S. and foreign patents pending (ou autres brevets americains et etrangers en attente).

**HEAT & GLO** Heat & Glo, a brand of Hearth & Home Technologies, Inc.  
Where everything comes together 20802 Kensington Boulevard, Lakeville, MN 55044

Not for use with solid fuel.  
*(Ne doit pas entre utilise avec un combustible solide).*

Type of Gas (Sorte De Gaz): This appliance must be installed in accordance with local codes, if any; if not, follow ANSI Z223.1 in the USA or CAN/CGA B149 installation codes. *(Installer l'appareil selon les codes ou reglements locaux ou, en l'absence de tels reglements, selon les codes d'installation CAN/CGA-B149.)*

**NATURAL GAS**

**GAS-FIRED**



**ANSI Z21XX-XXXX · CSA 2.XX-MXX · UL307B**

Minimum Permissible Gas Supply for Purposes of Input Adjustment.

Approved Minimum (De Gaz) Acceptable	0.0 in w.c.	(Po. Col. d'eau)
Maximum Pressure (Pression)	0.0 in w.c.	(Po. Col. d'eau)
Maximum Manifold Pressure (Pression)	0.0 in w.c.	(Po. Col. d'eau)
Minimum Manifold Pressure (Pression)	0.0 in w.c.	(Po. Col. d'eau)

Total Electrical Requirements: 000Vac, 00Hz., less than 00 Amperes

**MADE IN USA**

	IN CANADA		
ALTITUDE:	0-0000 FT.	0000-0000FT.	<b>Model:</b>
MAX. INPUT BTUH:	00,000	00,000	<b>(Modele):</b>
MIN. INPUT BTUH:	00,000	00,000	XXXXXXXX
ORIFICE SIZE:	#XXXXX	#XXXXX	<b>Serial</b>
			<b>(Serie):</b>
			XXXXXXXX

Model Number

Serial Number

# - Table of Contents -

<p><b>Section 1: Listing and Code Approvals</b></p> <ul style="list-style-type: none"> <li>A. Appliance Certification ..... 4</li> <li>B. BTU Specifications ..... 4</li> <li>C. High Altitude Installations ..... 4</li> <li>D. Non-Combustible Materials Specification ... 4</li> <li>E. Combustible Materials Specification ..... 4</li> <li>→ F. Requirements for the Commonwealth of Massachusetts ..... 5</li> </ul> <p><b>Section 2: Getting Started</b></p> <ul style="list-style-type: none"> <li>A. Design and Installation Considerations ..... 5</li> <li>B. Tools and Supplies Needed ..... 5</li> <li>C. Inspect Appliance and Components ..... 5</li> </ul> <p><b>Section 3: Framing and Clearances</b></p> <ul style="list-style-type: none"> <li>A. Selecting Appliance Location ..... 7</li> <li>B. Constructing the Appliance Chase ..... 8</li> <li>→ C. Clearances ..... 8</li> <li>→ D. Mantel Projections ..... 9</li> <li>E. Hearth Extension ..... 9</li> </ul> <p><b>Section 4: Termination Locations</b></p> <ul style="list-style-type: none"> <li>A. Vent Termination Minimum Clearances .... 10</li> </ul> <p><b>Section 5: Vent Information and Diagrams</b></p> <ul style="list-style-type: none"> <li>A. Vent Table Key ..... 12</li> <li>B. Use of Elbows ..... 12</li> <li>C. Measuring Standards ..... 12</li> <li>D. Vent Diagrams ..... 13</li> </ul> <p><b>Section 6: Vent Clearances and Framing</b></p> <ul style="list-style-type: none"> <li>A. Pipe Clearances to Combustibles ..... 16</li> <li>B. Wall Penetration Framing ..... 16</li> <li>C. Vertical Penetration Framing ..... 17</li> </ul> <p><b>Section 7: Appliance Preparation</b></p> <ul style="list-style-type: none"> <li>→ A. Removing Non-combustible Facing ..... 18</li> <li>→ B. Securing and Leveling the Appliance ..... 19</li> <li>→ C. Installing Non-combustible Facing ..... 19</li> <li>D. Installing Flue Restrictors ..... 20</li> <li>E. Adjusting Pilot Shield ..... 20</li> </ul> <p><b>Section 8: Installing Vent Pipe</b></p> <ul style="list-style-type: none"> <li>A. Assembly of Vent Sections ..... 21</li> <li>B. Disassembly of Vent Sections ..... 23</li> <li>C. Installing Heat Shield &amp; Termination Cap .24</li> <li>D. Installing Roof Flashing and Vertical Termination Cap ..... 25</li> </ul>	<p><b>Section 9: Gas Information</b></p> <ul style="list-style-type: none"> <li>A. Fuel Conversions ..... 27</li> <li>B. Gas Pressures ..... 27</li> <li>C. Gas Connection ..... 27</li> </ul> <p><b>Section 10: Electrical Information</b></p> <ul style="list-style-type: none"> <li>A. Recommendation for Wire ..... 29</li> <li>B. Connecting to the Appliance ..... 29</li> <li>C. Intellifire Ignition System Wiring ..... 29</li> <li>D. Junction Box Installation ..... 31</li> </ul> <p><b>Section 11: Finishing</b></p> <ul style="list-style-type: none"> <li>A. Mantel Projections ..... 32 ←</li> <li>B. Facing Material ..... 32 ←</li> <li>C. Finishing Material Requirements ..... 33 ←</li> <li>D. Hearth Extension ..... 34</li> </ul> <p><b>Section 12: Appliance Setup</b></p> <ul style="list-style-type: none"> <li>A. Remove Shipping Materials ..... 35</li> <li>B. Clean the Appliance ..... 35</li> <li>C. Accessories ..... 35</li> <li>D. Ember Placement ..... 36</li> <li>E. Positioning the Logs ..... 37</li> <li>F. Glass Assembly ..... 40</li> <li>G. Grilles and Trim ..... 40</li> <li>H. Air Shutter Setting ..... 40</li> </ul> <p><b>Section 13: Operating Instructions</b></p> <ul style="list-style-type: none"> <li>A. Before Lighting Appliance ..... 41</li> <li>B. Lighting Appliance ..... 42</li> <li>C. After Appliance is Lit ..... 43</li> <li>D. Frequently Asked Questions ..... 43</li> </ul> <p><b>Section 14: Troubleshooting</b></p> <ul style="list-style-type: none"> <li>A. Intellifire Ignition System ..... 44</li> </ul> <p><b>Section 15: Maintaining and Servicing Appliance. .... 46</b></p> <p><b>Section 16: Reference Materials</b></p> <ul style="list-style-type: none"> <li>A. Appliance Dimensions Diagram ..... 48</li> <li>B. Vent Components Diagrams ..... 49</li> <li>C. Service Parts ..... 52 ←</li> <li>D. Warranty ..... 55</li> <li>E. Contact Information ..... 56</li> </ul>
--	---

→ = Contains updated information.

# 1

## Listing and Code Approvals

### A. Appliance Certification

**MODEL:** GEM-42B

**LABORATORY:** Underwriters Laboratories, Inc. (UL)

**TYPE:** Direct Vent Gas Fireplace Heater

**STANDARD:** ANSI Z21.88-2002•CSA2.33-M02•UL307B

This product is listed to ANSI standards for “Vented Gas Appliance Heaters” and applicable sections of “Gas Burning Heating Appliances for Manufactured Homes and Recreational Vehicles”, and “Gas Fired Appliances for Use at High Altitudes”.

**NOT INTENDED FOR USE AS A PRIMARY HEAT SOURCE.**

This appliance is tested and approved as either supplemental room heat or as a decorative appliance. It should not be factored as primary heat in residential heating calculations.

**NOTE:** This installation must conform with local codes. In the absence of local codes you must comply with the **National Fuel Gas Code, ANSI Z223.1-latest edition** in the U.S.A. and the **CAN/CGA B149 Installation Codes** in Canada.

This model may be installed in a bedroom or bed-sitting room in the U.S.A. and Canada.

### B. BTU Specifications

Model (U.S. or Canada)		Maximum Input BTUH	Minimum Input BTUH	Orifice Size (DMS)
GEM-42B (NG)	US (0-2000 FT)	47,000	35,000	29
	CAN (2000-4500 FT)	42,300	31,500	30

### C. High Altitude Installations

U.L. Listed gas appliances are tested and approved without requiring changes for elevations from 0 to 2000 feet in the U.S.A. and Canada.

When installing this appliance at an elevation above 2000 feet, it may be necessary to decrease the input rating by changing the existing burner orifice to a smaller size. Input rate should be reduced by 4% for each 1000 feet above a 2000 foot elevation in the U.S.A., or 10% for elevations between 2000 and 4500 feet in Canada. If the heating value of the gas has been reduced, these rules do not apply. To identify the proper orifice size, check with the local gas utility.

If installing this appliance at an elevation above 4500 feet (in Canada), check with local authorities.

**⚠ WARNING**

Do NOT use this appliance if any part has been under water. Immediately call a qualified service technician to inspect the appliance and to replace any part of the control system and any gas control which has been under water.

### D. Non-Combustible Materials Specification

Material which will not ignite and burn. Such materials are those consisting entirely of steel, iron, brick, tile, concrete, slate, glass or plasters, or any combination thereof. Materials that are reported as passing **ASTM E 136, Standard Test Method for Behavior of Materials in a Vertical Tube Furnace at 750°C**, shall be considered non-combustible materials.

### E. Combustible Materials Specification

Materials made of or surfaced with wood, compressed paper, plant fibers, plastics, or other material that can ignite and burn, whether flame proofed or not, or whether plastered or unplastered shall be considered combustible materials.



Heat & Glo Quality Systems  
registered by SGS ICS

**NOTE:** The following requirements reference various Massachusetts and national codes not contained in this document.

## → F. Requirements for the Commonwealth of Massachusetts

For all side wall horizontally vented gas fueled equipment installed in every dwelling, building or structure used in whole or in part for residential purposes, including those owned or operated by the Commonwealth and where the side wall exhaust vent termination is less than seven (7) feet above finished grade in the area of the venting, including but not limited to decks and porches, the following requirements shall be satisfied:

### Installation of Carbon Monoxide Detectors

At the time of installation of the side wall horizontal vented gas fueled equipment, the installing plumber or gasfitter shall observe that a hard wired carbon monoxide detector with an alarm and battery back-up is installed on the floor level where the gas equipment is to be installed. In addition, the installing plumber or gasfitter shall observe that a battery operated or hard wired carbon monoxide detector with an alarm is installed on each additional level of the dwelling, building or structure served by the side wall horizontal vented gas fueled equipment. It shall be the responsibility of the property owner to secure the services of qualified licensed professionals for the installation of hard wired carbon monoxide detectors.

In the event that the side wall horizontally vented gas fueled equipment is installed in a crawl space or an attic, the hard wired carbon monoxide detector with alarm and battery back-up may be installed on the next adjacent floor level.

In the event that the requirements of this subdivision cannot be met at the time of completion of installation, the owner shall have a period of thirty (30) days to comply with the above requirements; provided, however, that during said thirty (30) day period, a battery operated carbon monoxide detector with an alarm shall be installed.

### Approved Carbon Monoxide Detectors

Each carbon monoxide detector as required in accordance with the above provisions shall comply with NFPA 720 and be ANSI/UL 2034 listed and IAS certified.

### Signage

A metal or plastic identification plate shall be permanently mounted to the exterior of the building at a minimum height of eight (8) feet above grade directly in line with the exhaust vent terminal for the horizontally vented gas fueled heating appliance or equipment. The sign shall read, in print size no less than one-half (1/2) inch in size, "**GAS VENT DIRECTLY BELOW. KEEP CLEAR OF ALL OBSTRUCTIONS**".

### Inspection

The state or local gas inspector of the side wall horizontally vented gas fueled equipment shall not approve the installation unless, upon inspection, the inspector observes carbon monoxide detectors and signage installed in accordance with the provisions of 248 CMR 5.08(2)(a)1 through 4.

### Exemptions

The following equipment is exempt from 248 CMR 5.08(2)(a)1 through 4:

- The equipment listed in Chapter 10 entitled "Equipment Not Required To Be Vented" in the most current edition of NFPA 54 as adopted by the Board; and
- Product Approved side wall horizontally vented gas fueled equipment installed in a room or structure separate from the dwelling, building or structure used in whole or in part for residential purposes.

## MANUFACTURER REQUIREMENTS

### Gas Equipment Venting System Provided

When the manufacturer of Product Approved side wall horizontally vented gas equipment provides a venting system design or venting system components with the equipment, the instructions provided by the manufacturer for installation of the equipment and the venting system shall include:

- Detailed instructions for the installation of the venting system design or the venting system components; and
- A complete parts list for the venting system design or venting system.

### Gas Equipment Venting System NOT Provided

When the manufacturer of a Product Approved side wall horizontally vented gas fueled equipment does not provide the parts for venting the flue gases, but identifies "special venting systems", the following requirements shall be satisfied by the manufacturer:

- The referenced "special venting system" instructions shall be included with the appliance or equipment installation instructions; and
- The "special venting systems" shall be Product Approved by the Board, and the instructions for that system shall include a parts list and detailed installation instructions.

A copy of all installation instructions for all Product Approved side wall horizontally vented gas fueled equipment, all venting instructions, all parts lists for venting instructions, and/or all venting design instructions shall remain with the appliance or equipment at the completion of the installation.

**See Gas Connection section for additional Commonwealth of Massachusetts requirements.**

# 2

## Getting Started

### A. Design and Installation Considerations

Heat & Glo direct vent gas appliances are designed to operate with all combustion air siphoned from outside of the building and all exhaust gases expelled to the outside. No additional outside air source is required.

#### CAUTION

- Check building codes prior to installation.
- Installation **MUST** comply with local, regional, state and national codes and regulations.
  - Consult local building, fire officials or authorities having jurisdiction about restrictions, installation inspection, and permits.

When planning an appliance installation, it's necessary to determine the following information before installing:

- Where the appliance is to be installed.
- The vent system configuration to be used.
- Gas supply piping.
- Electrical wiring.
- Framing and finishing details.
- Whether optional accessories—devices such as a fan, wall switch, or remote control—are desired.



#### WARNING

- Keep appliance dry.
- Mold or rust may cause odors.
  - Water may damage controls.



### B. Tools and Supplies Needed

Before beginning the installation be sure that the following tools and building supplies are available.

- |                        |  |
|------------------------|--|
| Reciprocating saw      | Framing material                                     |
| Pliers                 | Hi temp caulking material                            |
| Hammer                 | Gloves   |
| Phillips screwdriver   | Framing square                                       |
| Flat blade screwdriver | Electric drill and bits (1/4 in.)                    |
| Plumb line             | Safety glasses                                       |
| Level                  | 1/2 - 3/4 inch length, #6 or #8 Self-drilling screws |
| Manometer              | Voltmeter  |
| Tape measure           | Noncorrosive leak check solution                     |
- One 1/4 inch female connection (for optional fan).

### C. Inspect Appliance and Components

#### WARNING



Inspect appliance and components for damage. Damaged parts may impair safe operation.

- Do NOT install damaged components.
- Do NOT install incomplete components.
- Do NOT install substitute components.



Report damaged parts to dealer.

- Carefully remove the appliance and components from the packaging.
- The vent system components and trim doors are shipped in separate packages.
- The gas logs may be packaged separately and must be field installed.
- Report to your dealer any parts damaged in shipment, particularly the condition of the glass.
- **Read all of the instructions before starting the installation. Follow these instructions carefully during the installation to ensure maximum safety and benefit.**



#### WARNING

Hearth & Home Technologies disclaims any responsibility for, and the warranty will be voided by, the following actions:

- Installation and use of any damaged appliance or vent system component.
- Modification of the appliance or vent system.
- Installation other than as instructed by Hearth & Home Technologies.
- Improper positioning of the gas logs or the glass door.
- Installation and/or use of any component part not approved by Hearth & Home Technologies.

**Any such action may cause a fire hazard.**

# 3

## Framing and Clearances

**NOTE:**

- Illustrations reflect typical installations and are **FOR DESIGN PURPOSES ONLY**.
- Illustrations/diagrams are not drawn to scale.
- Actual installation may vary due to individual design preference.

**WARNING**



- Fire Risk  
Provide adequate clearance:
- Around air openings
  - To combustibles
  - For service access
- Locate appliance away from traffic areas.

### A. Selecting Appliance Location

When selecting a location for your appliance it is important to consider the required clearances to walls (see Figure 3.1).

**NOTE: For actual appliance dimensions refer to Section 16.**

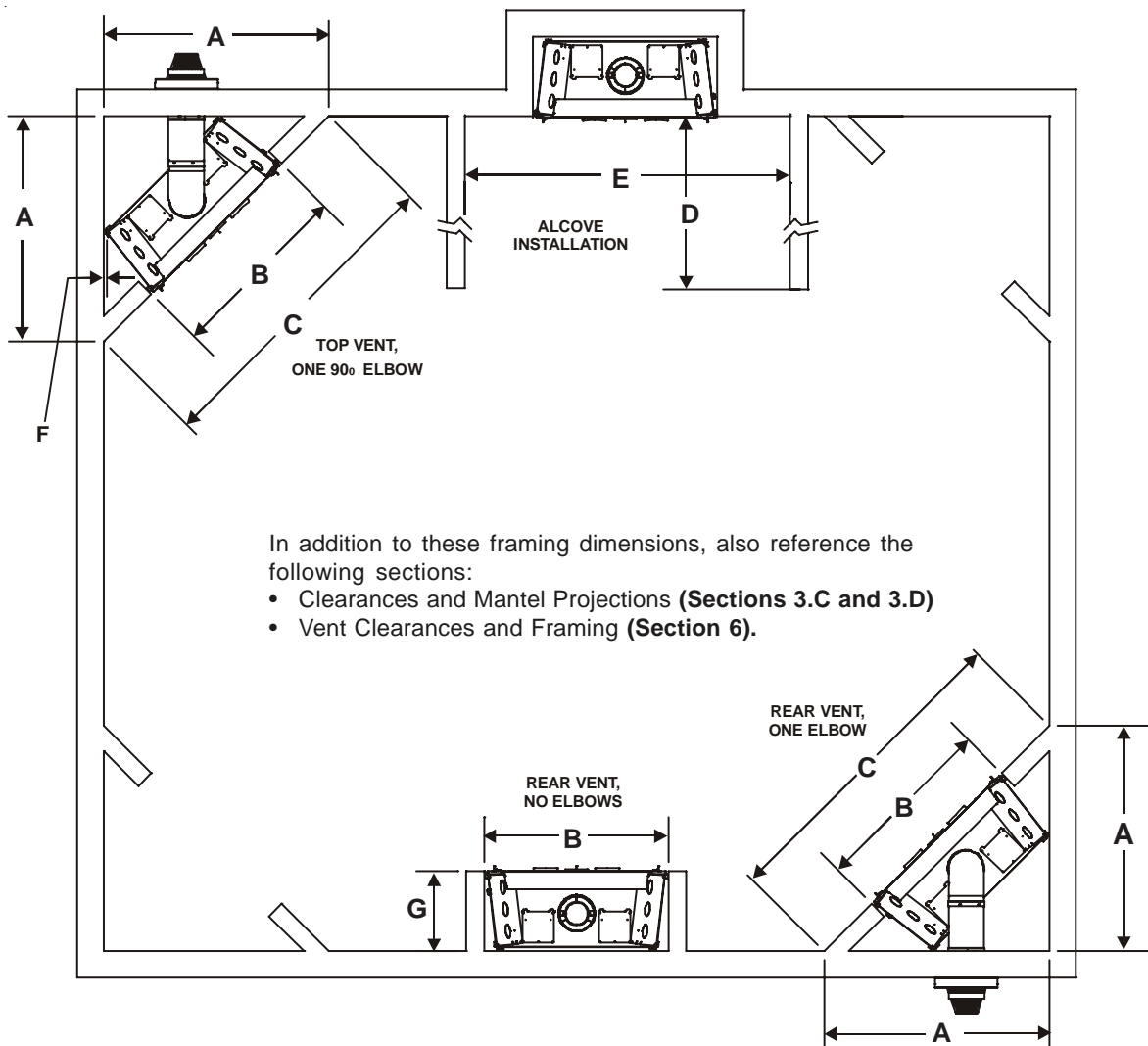

	A	B	C	D	E	F	G
Inches	55-1/4	47-1/2	78-1/2	36	65-1/2	1/2	18
Millimeters	1403	1207	1994	914	1664	13	457

Figure 3.1 Appliance Locations

## B. Constructing the Appliance Chase

A chase is a vertical boxlike structure built to enclose the gas appliance and/or its vent system. Vertical vents that run on the outside of a building may be, but are not required to be, installed inside a chase.

Construction of the chase may vary with the type of building. These instructions are not substitutes for the requirements of local building codes. Local building codes **MUST** be checked.

Chases should be constructed in the manner of all outside walls of the home to prevent cold air drafting problems. The chase should not break the outside building envelope in any manner.

Walls, ceiling, base plate and cantilever floor of the chase should be insulated. Vapor and air infiltration barriers should be installed in the chase as per regional codes for the rest of the home. Additionally, in regions where cold air infiltration may be an issue, the inside surfaces may be sheetrocked and taped for maximum air tightness.

To further prevent drafts, the wall shield and ceiling firestops should be caulked with high temperature caulk to seal gaps. Gas line holes and other openings should be caulked with

high temp caulk or stuffed with unfaced insulation. If the appliance is being installed on a cement slab, a layer of plywood may be placed underneath to prevent conducting cold up into the room.

## C. Clearances

**⚠ WARNING**

**Fire Risk.**  
**Odor Risk.**

- Install appliance on hard metal or wood surfaces extending full width and depth of appliance.
- Do NOT install appliance directly on carpeting, vinyl, tile or any combustible material other than wood.

**⚠ WARNING**

**Fire Risk.**

- Construct chase to all clearance specifications in manual.
- Locate and install appliance to all clearance specifications in manual

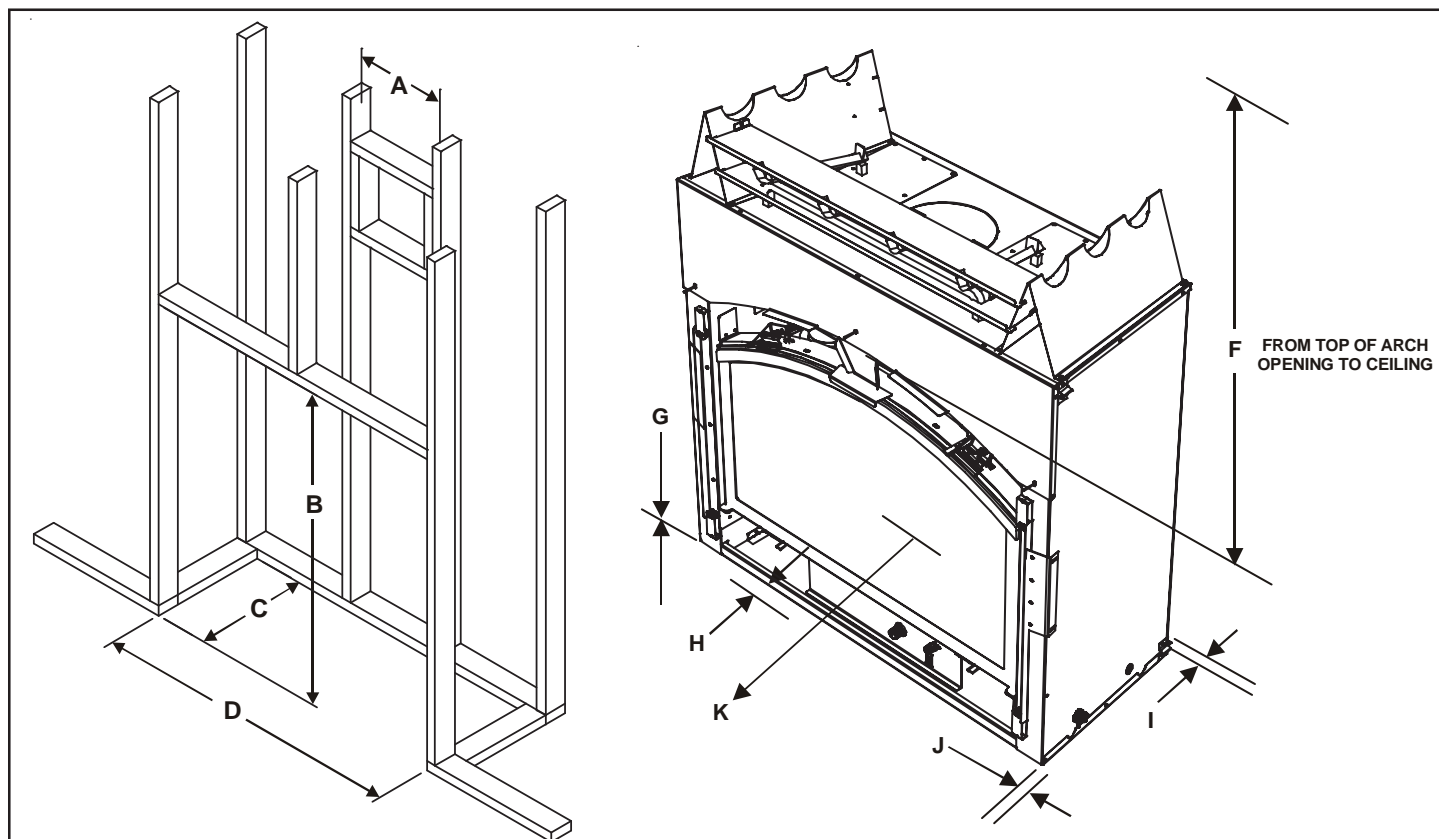

CLEARANCES TO COMBUSTIBLES:										
	A	B	C	D	E	F	G	H	I	J
	Rough Opening (Vent Pipe)	Rough Opening (Height)	Rough Opening (Depth)	Rough Opening (Width)	Clearance to Ceiling	Non-Combustible Floor	Combustible Flooring	Behind Appliance	Sides of Appliance	Front of Appliance
Inches	10	47-3/4	17-1/2	47-1/2	48	0	8	1/2	1/2	36
mm	254	1213	445	1207	1219	0	203	13	13	914

→ Figure 3.2 Clearances to Combustibles



## D. Mantel Projections

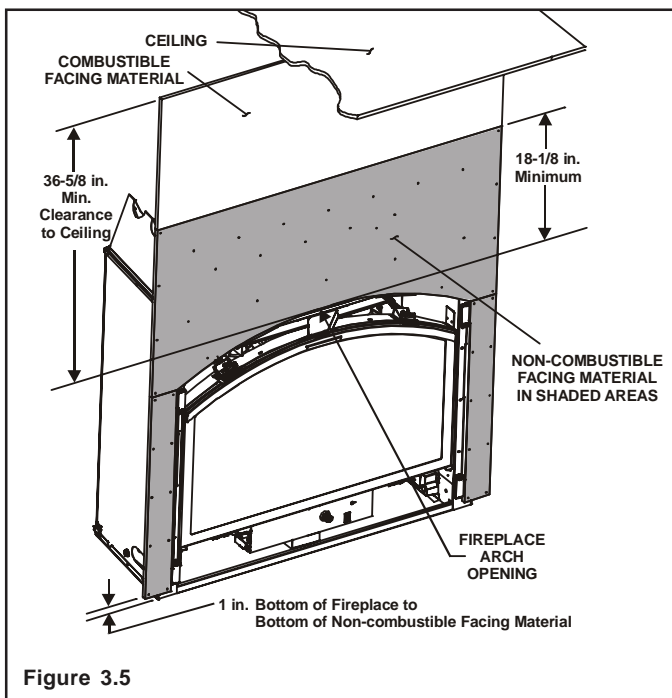
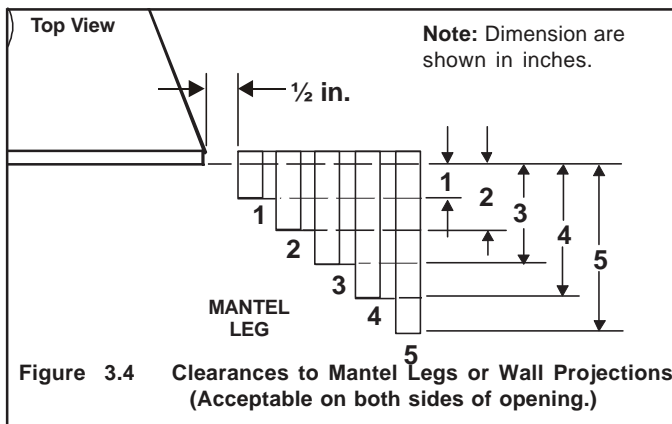
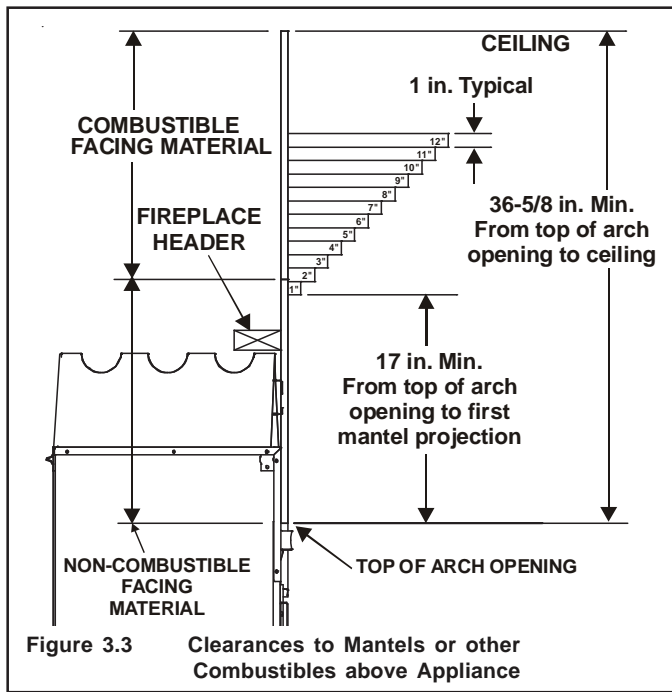

## E. Hearth Extension

**WARNING**

 Fire Risk.  
Hearth extension required to protect combustible floors in front of appliance.

- An 8 inch minimum hearth extension must be constructed of non-combustible material.

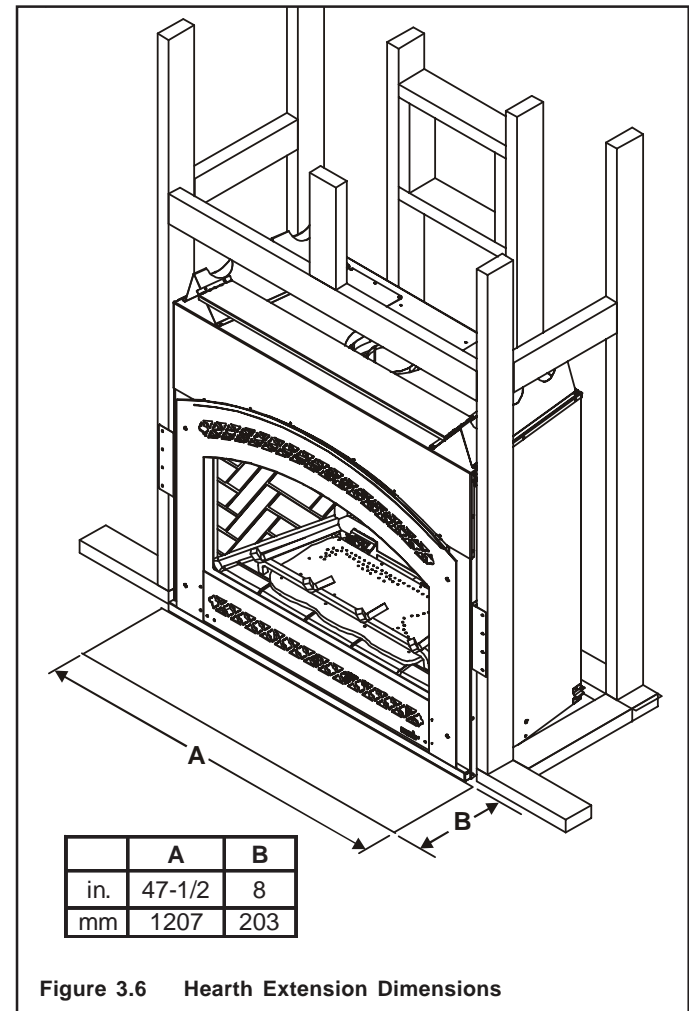

# 4

## Termination Locations

### A. Vent Termination Minimum Clearances

**⚠ WARNING**

Fire Risk.  
Explosion Risk.  
Maintain vent clearance to combustibles as specified.

- Do not pack air space with insulation or other materials.

Failure to keep insulation or other materials away from vent pipe may cause fire.

Measure vertical clearances from this surface.

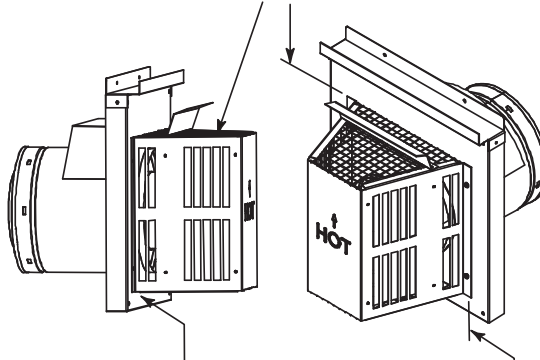

Measure horizontal clearances from this surface.

(See Figure 4.4 for specific clearances)

**Figure 4.1**

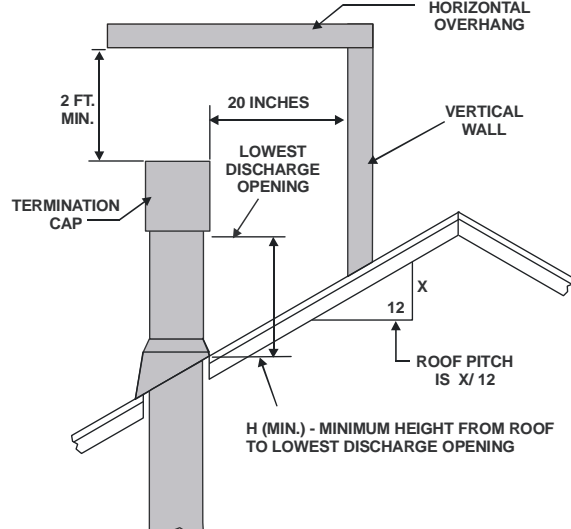

Roof Pitch	H (Min.) Ft.
Flat to 6/12	1.0*
Over 6/12 to 7/12	1.25*
Over 7/12 to 8/12	1.5*
Over 8/12 to 9/12	2.0*
Over 9/12 to 10/12	2.5
Over 10/12 to 11/12	3.25
Over 11/12 to 12/12	4.0
Over 12/12 to 14/12	5.0
Over 14/12 to 16/12	6.0
Over 16/12 to 18/12	7.0
Over 18/12 to 20/12	7.5
Over 20/12 to 21/12	8.0

\* 3 foot minimum in snow regions

**Figure 4.2 Minimum Height from Roof to Lowest Discharge Opening**

Figure 4.2 specifies minimum vent heights for various pitched roofs.

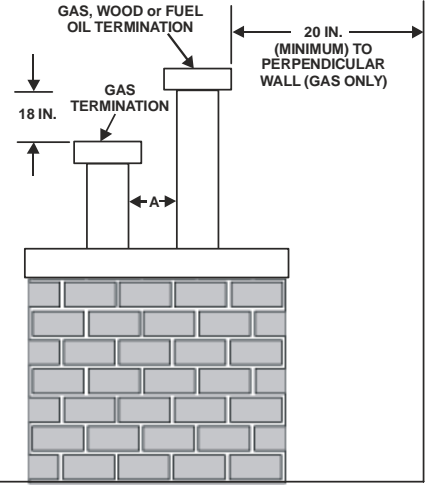

Gas Termination	Wood & Fuel Oil Termination
A	6 in. / 20 in.

**Figure 4.3 Multiple Vertical Termination**

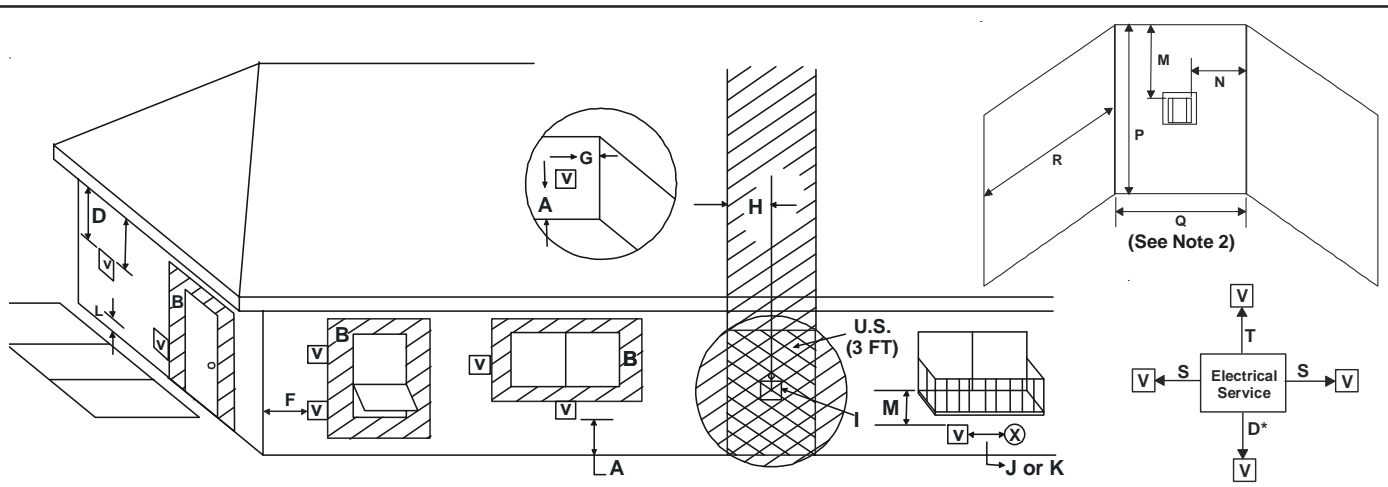

**V** = VENT TERMINAL      **X** = AIR SUPPLY INLET      = AREA WHERE TERMINAL IS NOT PERMITTED

- A = 12 inches ..... clearances above grade, veranda, porch, deck or balcony  
(See Note 1)
- B = 12 inches ..... clearances to window or door that may be opened, or to permanently closed window. (Glass)
- D\* = 18 inches ..... vertical clearance to unventilated soffit or to ventilated soffit located above the terminal  
\*30 inches ..... for vinyl clad soffits and below electrical service
- F = 9 inches ..... clearance to outside corner
- G = 6 inches ..... clearance to inside corner
- H = 3 ft. (Canada) ..... not to be installed above a gas meter/regulator assembly within 3 feet (90cm) horizontally from the center-line of the regulator
- I = 3 ft. (U.S.A.)  
6 ft. (Canada) ..... clearance to gas service regulator vent outlet
- J = 9 inches (U.S.A.)  
12 inches (Canada) clearance to non-mechanical air supply inlet to building or the combustion air inlet to any other appliance

- K = 3 ft. (U.S.A.)  
6 ft. (Canada) ..... clearance to a mechanical (powered) air supply inlet
- L\*\* = 7 ft. .... clearance above paved sidewalk or a paved driveway located on **public** property  
(See Note 1)
- M\*\*\* = 18 inches ..... clearance under veranda, porch, deck, balcony or overhang  
42 inches ..... vinyl

**Alcove Applications**

- N = 6 inches ..... non-vinyl sidewalls  
12 inches ..... vinyl sidewalls
- P = 8 ft.

	Q <sub>MIN</sub>	R <sub>MAX</sub>
1 cap	3 feet	2 x Q <sub>ACTUAL</sub>
2 caps	6 feet	1 x Q <sub>ACTUAL</sub>
3 caps	9 feet	2/3 x Q <sub>ACTUAL</sub>
4 caps	12 feet	1/2 x Q <sub>ACTUAL</sub>
Q <sub>MIN</sub> = # termination caps x 3		R <sub>MAX</sub> = (2 / # termination caps) x Q <sub>ACTUAL</sub>

- S = 6 inches ..... clearance from sides of electrical service  
(See Note 5)
- T = 12 inches ..... clearance above electrical service  
(See Note 5)

\*\* a vent shall not terminate directly above a sidewalk or paved driveway which is located between two single family dwellings and serves both dwellings.

\*\*\* only permitted if veranda, porch, deck or balcony is fully open on a minimum of 2 sides beneath the floor, or meets Note 2.

**NOTE 1:** On private property where termination is less than 7 feet above a sidewalk, driveway, deck, porch, veranda or balcony, use of a listed cap shield is suggested. (See vents components page)

**NOTE 2:** Termination in an alcove space (spaces open only on one side and with an overhang) are permitted with the dimensions specified for vinyl or non-vinyl siding and soffits. **1.** There must be 3 feet minimum between termination caps. **2.** All mechanical air intakes within 10 feet of a termination cap must be a minimum of 3 feet below the termination cap. **3.** All gravity air intakes within 3 feet of a termination cap must be a minimum of 1 foot below the termination cap.

**Figure 4.4 Minimum Clearances for Termination**

**NOTE 3:** Local codes or regulations may require different clearances.

**NOTE 4:** Termination caps may be hot. Consider their proximity to doors or other traffic areas.

**NOTE 5:** Location of the vent termination must not interfere with access to the electrical service.

**WARNING: In the U.S:** Vent system termination is **NOT** permitted in screened porches. You must follow side wall, overhang and ground clearances as stated in the instructions.

**In Canada:** Vent system termination is **NOT** permitted in screened porches. Vent system termination is permitted in porch areas with two or more sides open. You must follow all side walls, overhang and ground clearances as stated in the instructions.

Heat & Glo assumes no responsibility for the improper performance of the appliance when the venting system does not meet these requirements.

**CAUTION: IF EXTERIOR WALLS ARE FINISHED WITH VINYL SIDING, IT IS SUGGESTED THAT A VINYL PROTECTOR KIT BE INSTALLED.**

# 5

## Vent Information and Diagrams

### A. Vent Table Key

The abbreviations listed in this vent table key are used in the vent diagrams.

Symbol	Description
V <sub>1</sub>	First section (closest to appliance) of vertical length
V <sub>2</sub>	Second section of vertical length
H <sub>1</sub>	First section (closest to appliance) of horizontal length
H <sub>2</sub>	Second section of horizontal length

### WARNING



Fire Hazard.  
Explosion Risk.  
Asphyxiation Risk.  
Do NOT connect this gas appliance to a chimney flue serving a separate solid-fuel or gas burning appliance.



- Vent this appliance directly outside.
  - Use separate vent system for this appliance.
- May impair safe operation of this appliance or other appliances connected to the flue.

### B. Use of Elbows

### CAUTION

ALL vent configuration specifications MUST be followed.

- This product is tested and listed to these specifications.
- Appliance performance will suffer if specifications are not followed.

Diagonal runs have both vertical and horizontal vent aspects when calculating the effects. Use the rise for the vertical aspect and the run for the horizontal aspect (see Figure 5.1).

Two 45° elbows may be used in place of one 90° elbow. On 45° runs, one foot of diagonal is equal to 8.5 inches horizontal run and 8.5 inches vertical run. A length of straight pipe is allowed between two 45° elbows (see Figure 5.1).

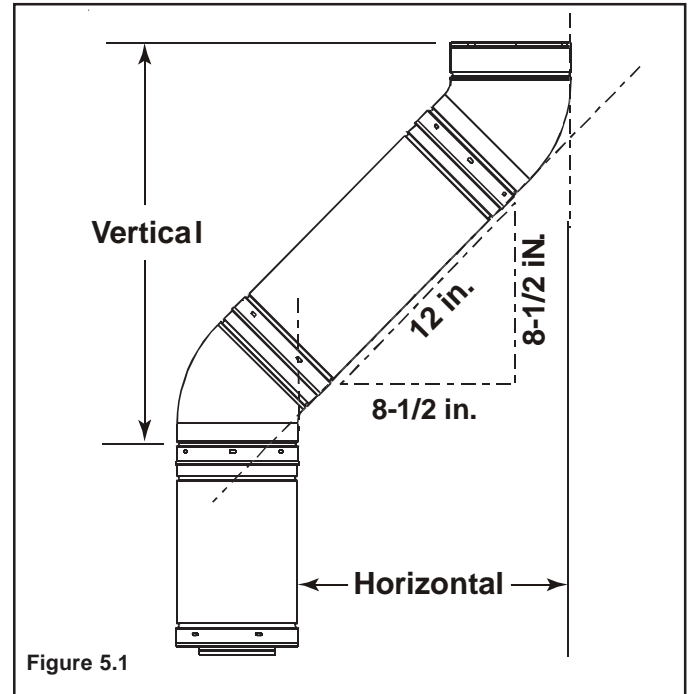

Figure 5.1

### C. Measuring Standards

Vertical and horizontal measurements listed in the vent diagrams were made using the following standards.

1. Pipe measurements are shown using the effective length of pipe (see Figure 5.2).
2. Measurements are made from the appliance outer wrap, not from the standoffs.
3. Horizontal terminations are measured to the outside mounting surface (flange of termination cap) (see Figure 4.1).
4. Vertical terminations are measured to bottom of termination cap.
5. Horizontal pipe installed level with no rise.

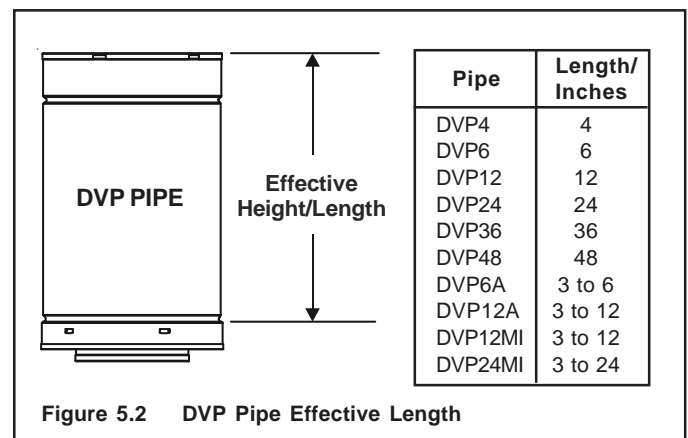

Figure 5.2 DVP Pipe Effective Length

## D. Vent Diagrams

### ⚠ WARNING



Fire Risk. Explosion Risk.

Do NOT pack insulation or other combustibles between ceiling firestops.

- ALWAYS maintain specified clearances around venting and firestop systems.
- Install wall shield and ceiling firestops as specified.

Failure to keep insulation or other material away from vent pipe may cause fire.



### 1. Top Vent - Horizontal Termination

#### One Elbow

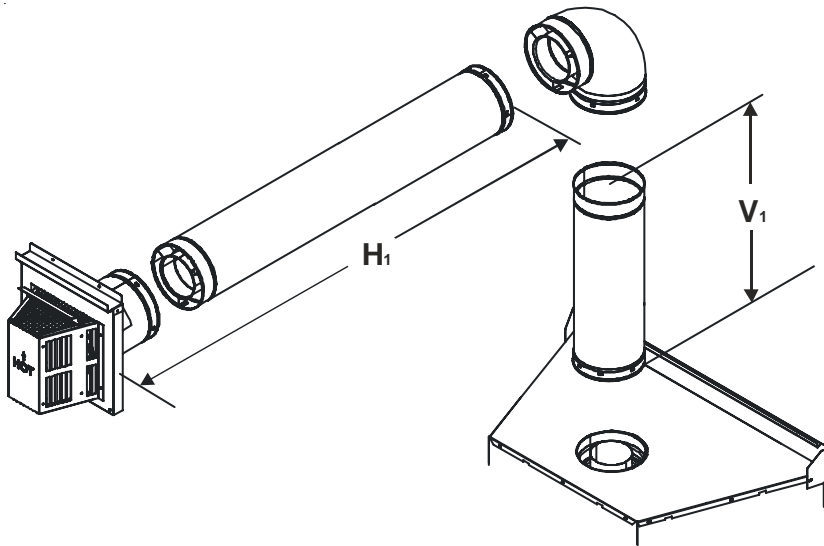

$V_1$ Minimum		$H_1$ Maximum	
1.5 ft	457 mm	2 ft	610 mm
2 ft	610 mm	5 ft	1.5 m
3 ft	914 mm	8 ft	2.4 m
4 ft	1.2 m	11 ft	3.4 m
5 ft	1.5 m	14 ft	4.3 m
6 ft	1.8 m	17 ft	5.2 m
7 ft	2.1 m	20 ft	6.1 m
8 ft	2.4 m	23 ft	7.0 m

$V_1 = 40$  ft (12.2m) Maximum  
 $H_1 = 23$  ft (7.0 m) Maximum  
 $V_1 + H_1 = 63$  ft (19.2m) Maximum

**NOTE:** Must have an 18 inch minimum vertical vent before attaching a 90° elbow to the unit.

Figure 5.3

#### Two Elbows

**NOTE:** Must have an 18 inch minimum vertical vent before attaching a 90° elbow to the unit.

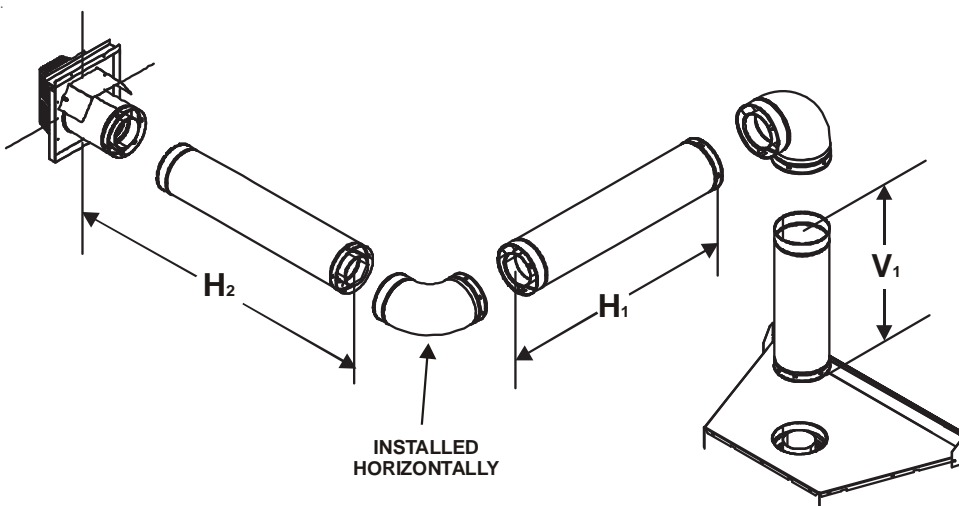

$V_1$ Minimum		$H_1 + H_2$ Maximum	
1.5 ft	457 mm	2 ft	610 mm
2 ft	610 mm	5 ft	1.5 m
3 ft	914 mm	8 ft	2.4 m
4 ft	1.2 m	11 ft	3.4 m
5 ft	1.5 m	14 ft	4.3 m
6 ft	1.8 m	17 ft	5.2 m
7 ft	2.1 m	20 ft	6.1 m
8 ft	2.4 m	23 ft	7.0 m

$V_1 + H_1 + H_2 = 63$  ft (19.2 m) Maximum  
 $H_1 + H_2 = 23$  ft (7.0 m) Maximum

Figure 5.4

# 1. Top Vent - Horizontal Termination - (continued)

## Three Elbows

**NOTE:** Must have an 18 inch minimum vertical vent before attaching a 90° elbow to the unit.

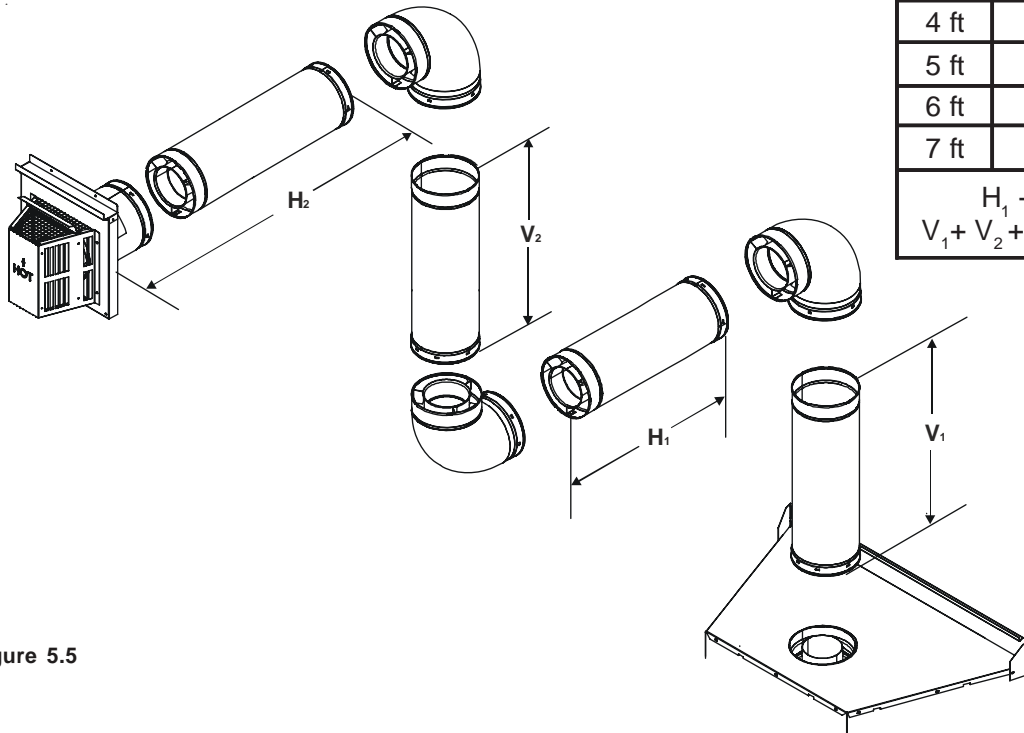

V <sub>1</sub> Minimum		H <sub>1</sub> + H <sub>2</sub> Maximum	
1.5 ft	457 mm	4 ft	1.2 m
2 ft	607 mm	7 ft	2.1 m
3 ft	914 mm	10 ft	3.0 m
4 ft	1.2 m	13	3.4 m
5 ft	1.5 m	16	4.9 m
6 ft	1.8 m	17	5.2 m
7 ft	2.1m	22	6.7 m

H<sub>1</sub> + H<sub>2</sub> = 22 ft (6.7 m) Max.  
V<sub>1</sub> + V<sub>2</sub> + H<sub>1</sub> + H<sub>2</sub> = 62 ft (18.9 m) Max.

Figure 5.5

# 2. Top Vent - Vertical Termination

V<sub>1</sub> = 40 FT MAX. (12.4 M)

## Straight Up Vertical Venting

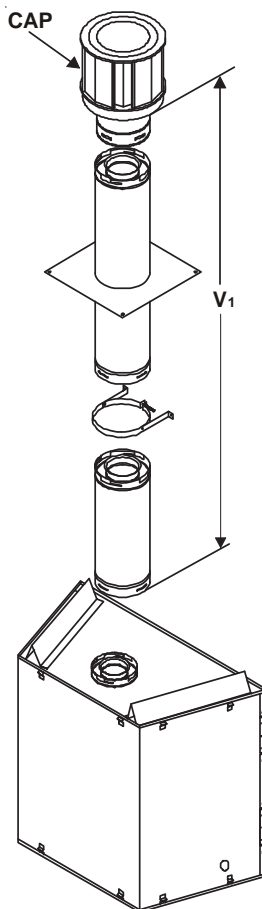

**NOTE:** On vertical venting configurations install the vertical baffle found in the appliance to the left of the control panel. Follow flue restrictor instructions in **Section 7B**.

Figure 5.6

## 2. Top Vent - Vertical Termination - (continued)

### Two Elbows

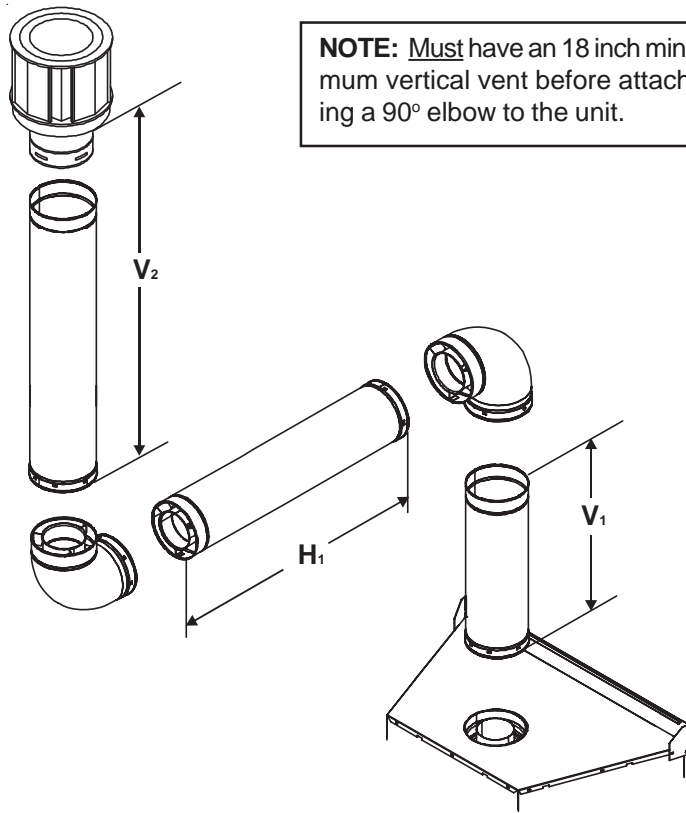

$V_1 + V_2$ Minimum		$H_1$ Maximum	
1.5 ft	457 mm	2 ft	610 mm
2 ft	610 mm	5 ft	1.5 m
3 ft	915 mm	8 ft	2.4 m
4 ft	1.2 m	11 ft	3.4 m
5 ft	1.5 m	14 ft	4.3 m
6 ft	1.8 m	17 ft	5.2 m
7 ft	2.1 m	20 ft	6.1 m
8 ft	2.4 m	23 ft	7.0 m

$H_1 = 23 \text{ ft (7.0 m) Max.}$   
 $V_1 + V_2 + H_1 = 63 \text{ ft (19.2 m) Max.}$

Figure 5.7

### Three Elbows

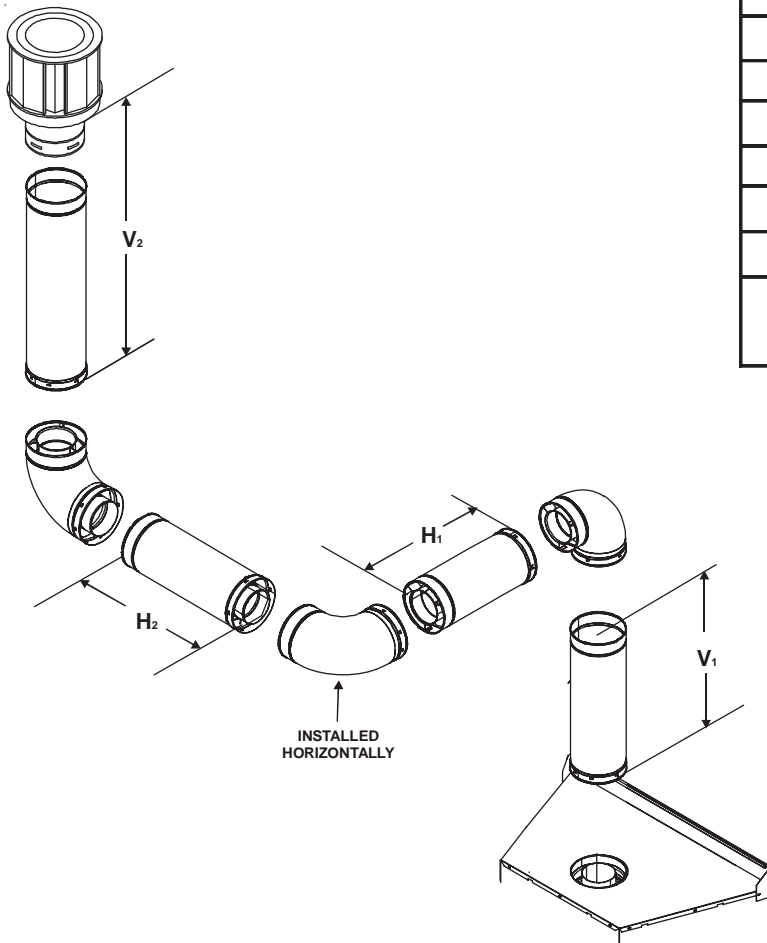

$V_1 + V_2$ Minimum		$H_1 + H_2$ Maximum	
1.5 ft	457 mm	4 ft	1.2 m
2 ft	610 mm	7 ft	2.1 m
3 ft	914 mm	10 ft	3.0 m
4 ft	1.2 m	13 ft	4.0 m
5 ft	1.5 m	16 ft	4.9 m
6 ft	1.8 m	19 ft	5.8 m
7 ft	2.1 m	22 ft	6.7 m

$H_1 + H_2 = 22 \text{ ft (6.7 m) Max.}$   
 $V_1 + V_2 + H_1 + H_2 = 62 \text{ ft (18.9 m) Max.}$

Figure 5.8

# 6

## Vent Clearances and Framing

### A. Pipe Clearances to Combustibles

**⚠ WARNING**

Fire Risk.  
Explosion Risk.  
Maintain vent clearance to combustibles as specified.

- Do not pack air space with insulation or other materials.

Failure to keep insulation or other materials away from vent pipe may cause fire.

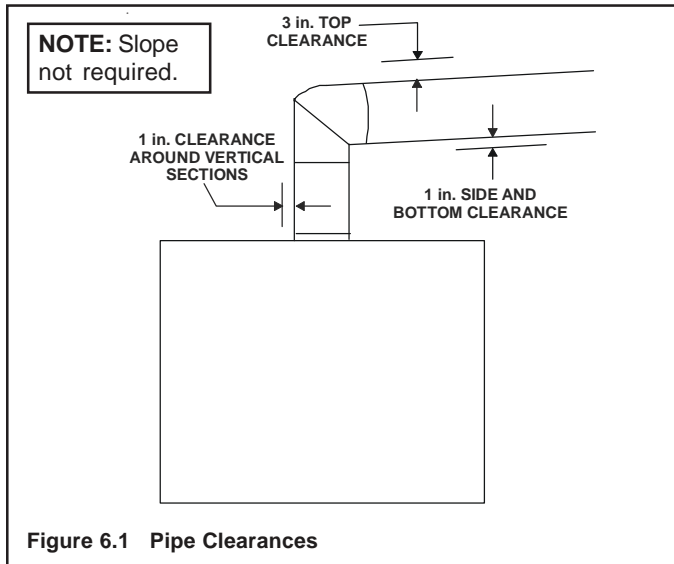

### B. Wall Penetration Framing

Shows center of 10" x 12" vent framing holes for top and rear venting. The center of the hole is one (1) inch (25.4mm) above the center of the horizontal vent pipe.

A*	B
33 -3/4 in.	65 in.

\* Heat-Out framing is 12 inches wide by 10 inches tall, opposite of vent framing. Center of Heat-Out framing is 1-1/16 inch LOWER than the center of the Heat-Out pipe.

**Figure 6.2 Exterior Wall Hole**

#### Combustible Wall Penetration

Frame a hole in a combustible wall for an interior wall shield firestop, (Figure 6.2) whenever a wall is penetrated. Use same size framing materials as those used in the wall construction. The wall shield firestop maintains minimum clearances and prevents cold air infiltration.

#### Non-Combustible Wall Penetration

If the hole being penetrated is surrounded by noncombustible materials such as concrete, a hole with diameter one inch greater than the pipe is acceptable.

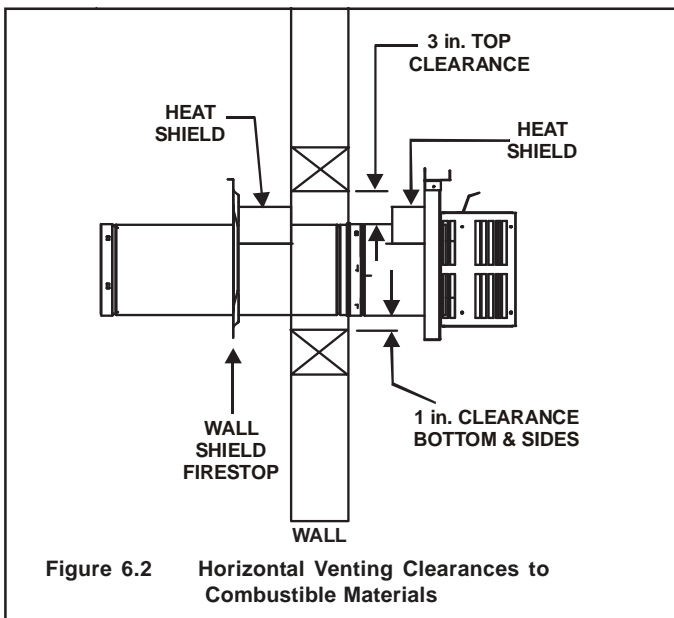



## C. Vertical Penetration Framing

**WARNING**

**Fire Hazard**

Keep loose materials or blown insulation from touching the vent pipe.

- National building codes recommend using attic shield to keep loose materials/blown insulation from contacting vent.
- Hearth & Home Technologies requires the use of an attic shield.

### Installing the Ceiling Firestop

- Frame an opening 10 inches by 10 inches whenever the vent system penetrates a ceiling/floor (see Figure 6.3).
- Frame the area with the same sized lumber as used in ceiling/floor joist.
- When installing a top vent vertical termination appliance the hole should be directly above the appliance, unless the flue is offset.
- Do not pack insulation around the vent. Insulation must be kept away from the pipe.

### Installing Attic Shield

**Note:** An additional ceiling firestop is not required if attic shield is used.

- Frame opening for attic shield.
- Attic shield may be installed above or below ceiling (see Figure 6.4).
- Secure with three fasteners on each side.
- Fold tabs at top of attic shield in toward vent pipe. Tabs must keep vent pipe centered within shield.
- Field construct additional shield height if insulation is deeper than height of attic shield.

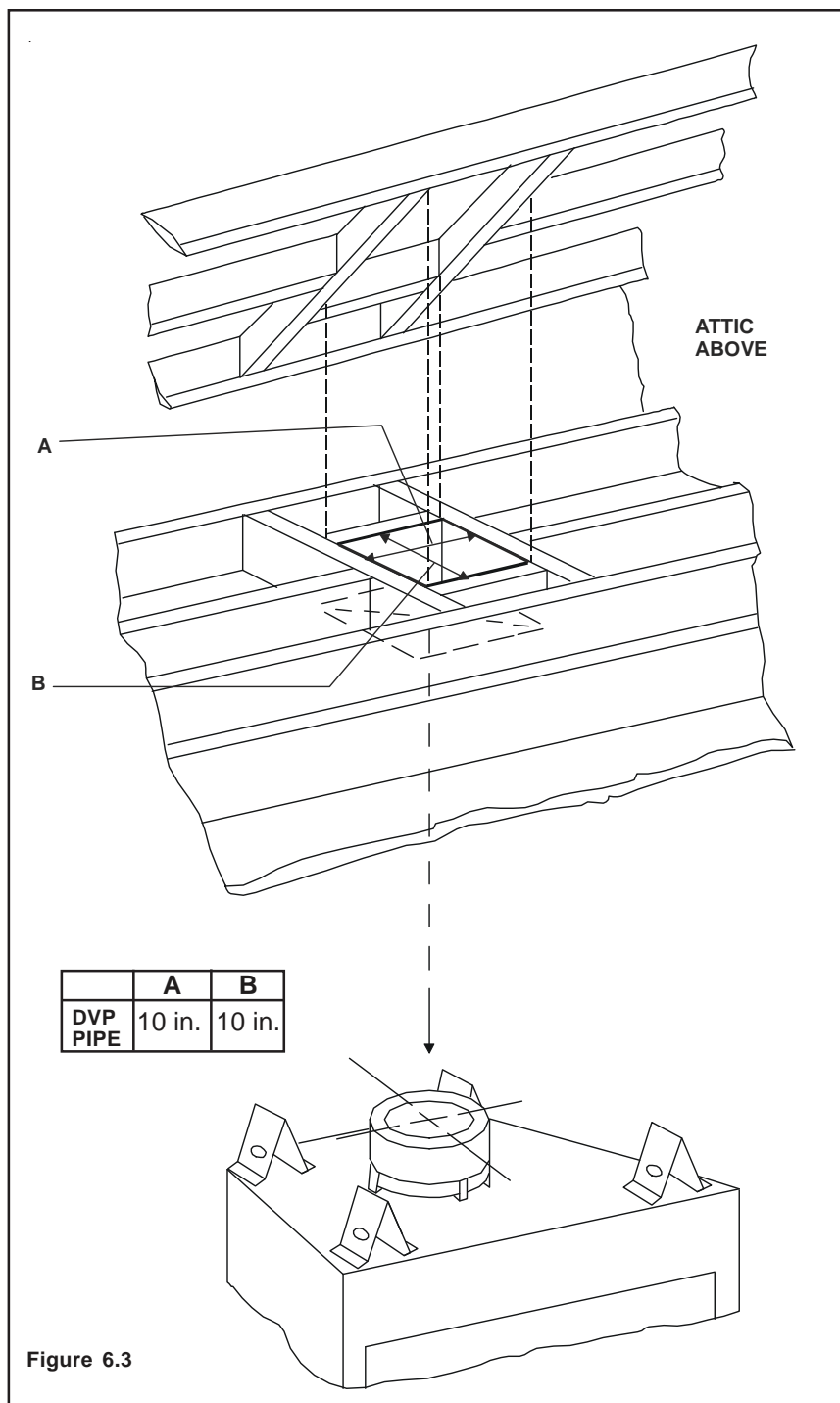

Figure 6.3

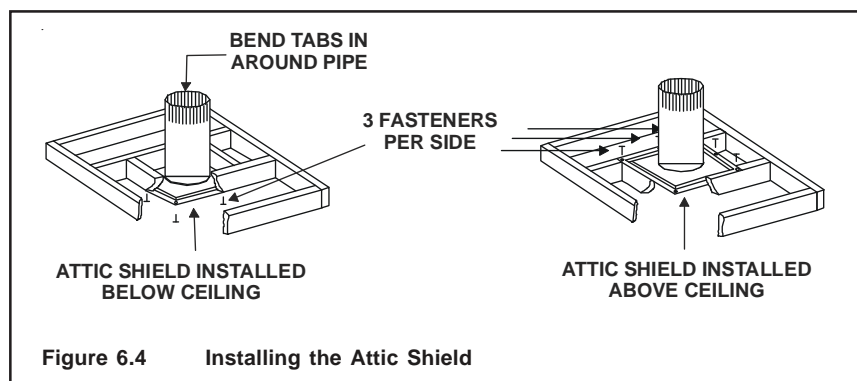

Figure 6.4 Installing the Attic Shield

# 7

## Appliance Preparation

### → A. Removing Non-combustible Facing Material Assembly

The non-combustible assembly is located on the back of appliance (see Figure 7.1).

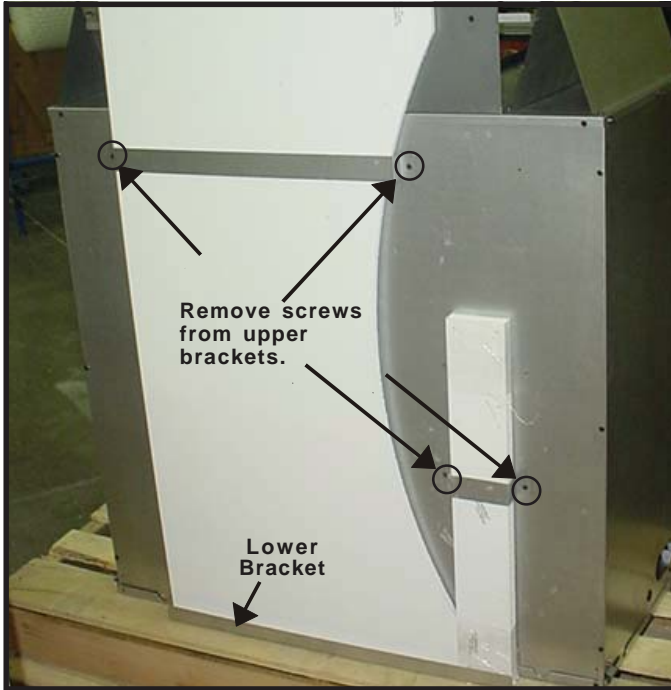

Figure 7.1 Non-Combustible Facing Material Assembly

### CAUTION

Handle with care.

- Non-combustible material may be damaged if dropped.

- Hold non-combustible pieces in place.
- Remove and save two screws from both upper brackets (see Figure 7.1).
- Remove non-combustible pieces.
- Remove and save three screws from lower bracket (see Figure 7.1).
- Remove 5 screws **A** from upper shelf (see Figure 7.2).
- Bend sheetmetal brace **B** away from unit (see Figure 7.2) until tabs **C** on shelf are released from standoffs.
- Remove 3 screws **D** at bottom of sheetmetal brace and remove brace from unit.
- Discard brackets, sheetmetal brace and shelf.
- Replace screws in holes where these pieces were attached to appliance.

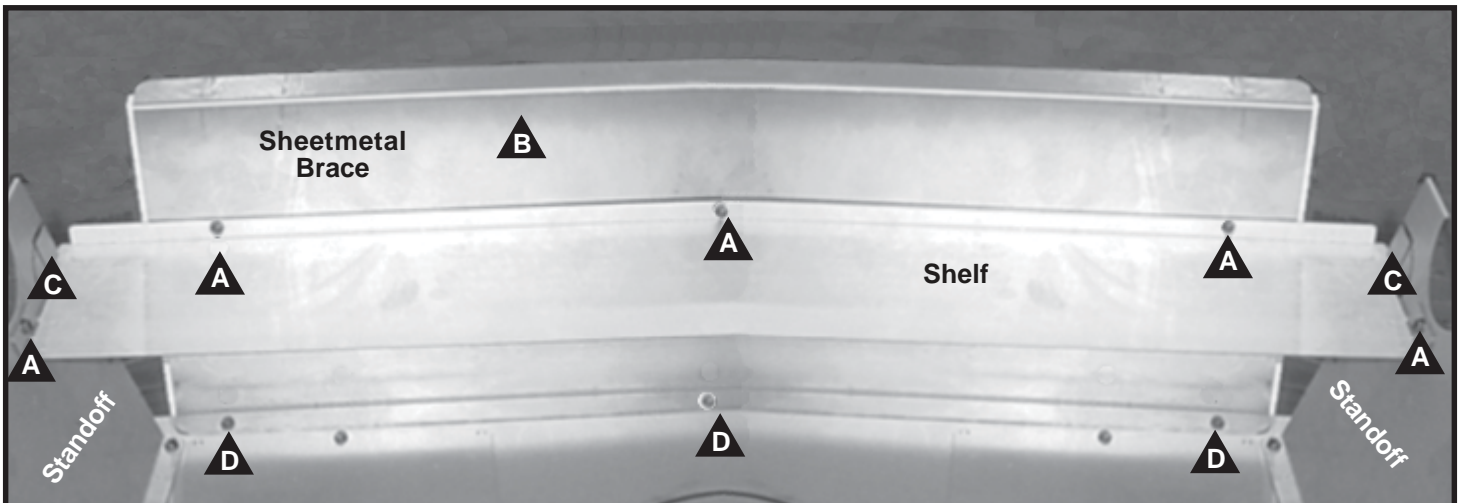

→ Figure 7.2 Sheetmetal Brace and Shelf (rear of appliance viewed from appliance front).

## B. Securing and Leveling the Appliance

<b>CAUTION</b>	
	<p>Sharp Edges</p> <ul style="list-style-type: none"> <li>Wear protective gloves and safety glasses during installation.</li> </ul>
	

<b>WARNING</b>	
	<p>Fire Risk.</p> <ul style="list-style-type: none"> <li>Prevent contact with sagging, loose insulation.</li> <li>Do NOT install against combustible materials such as exposed insulation, plastic and insulation backer.</li> </ul>

The diagram shows (Figure 7.3) the location of the nailing tabs which are provided to secure the appliance to the framing members .

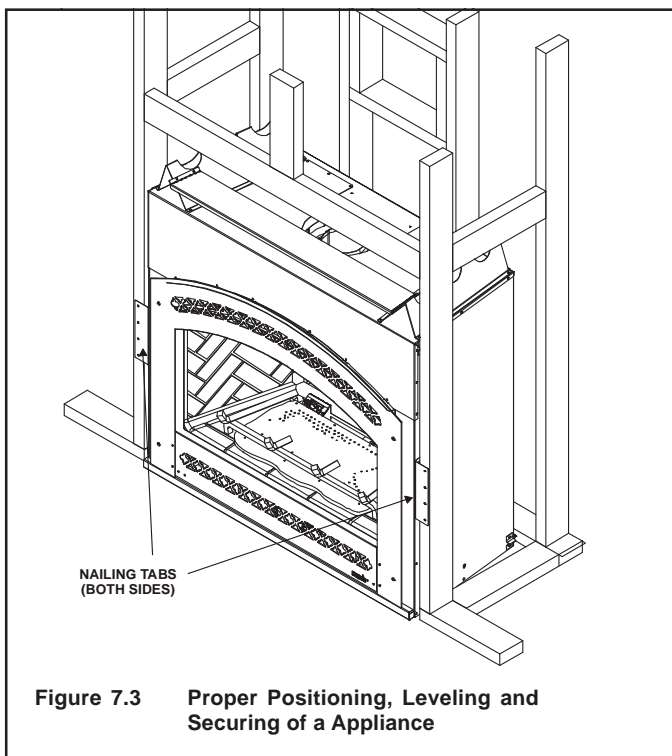

- Place the appliance into position.
- Level the appliance from side to side and front to back.
- Shim the appliance, as necessary. It is acceptable to use wood shims.
- Bend out nailing tabs on each side.
- Keep nailing tabs flush with the framing.
- Secure the appliance to the framing by using nails or screws through the nailing tabs.

<b>WARNING</b>		
<p>Fire Risk.</p> <ul style="list-style-type: none"> <li>ALWAYS maintain specified clearances around the appliance.</li> <li>Do NOT notch into the framing around the appliance spacers.</li> </ul> <p>Failure to keep insulation, framing or other material away from the appliance may cause fire.</p>		

## C. Installing Non-combustible Facing Material

<b>WARNING</b>	
	<p>Fire Risk.</p> <ul style="list-style-type: none"> <li>Follow these instructions exactly.</li> <li>Facing materials must be installed properly to prevent fire.</li> <li>No materials may be substituted without authorization by Hearth &amp; Home Technologies.</li> </ul>

- Center and attach top board to the framing members (see Figure 7.4).
- Use fasteners from fastener packet (in manual bag) in shaded areas (Figure 7.4).
- Use regular sheetrock screws in non-shaded areas (see Figure 7.4).

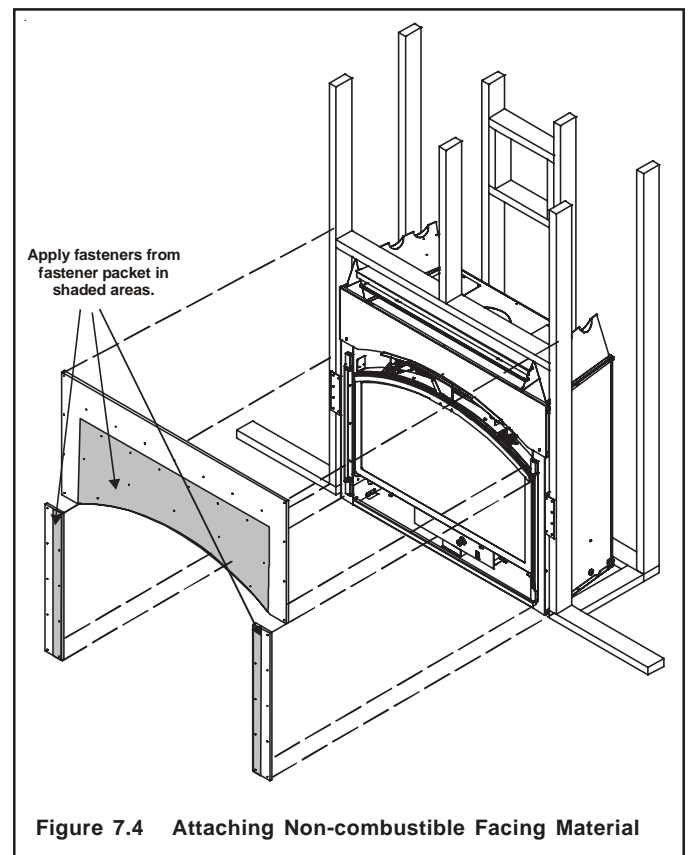

- Attach the left and right side pieces to the framing members. (See Figure 7.4).

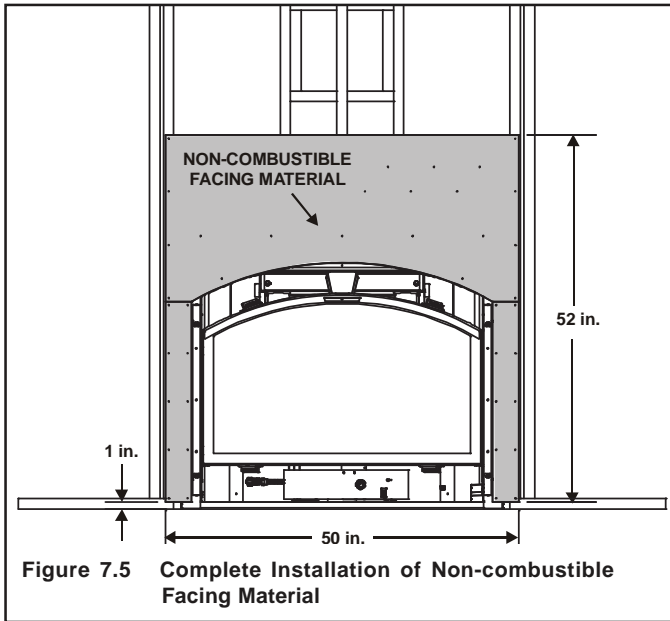

→ Figure 7.5 Complete Installation of Non-combustible Facing Material

- Use a wet or dry towel or soft brush to remove dust or dirt from facing material.
- Apply a non-combustible adhesive to attach tile, stone or other non-combustible finishing materials per manufacturer's instructions.

### D. Installing Flue Restrictors

Locate the flue restrictors inside the unit to the left of the control panel. Use the following table to determine which restrictors to use for the vent run.

Vent Run Vertical		15 ft. - 30 ft.	30 ft. - 40 ft.
<b>GEM-42B</b>	NG	1-3/4 in.	1-1/2 in.
	LP	2 in.	1-3/4 in.

Insert one restrictor into either the left or right of the 3 inch exhaust collar (see Figure 7.6).

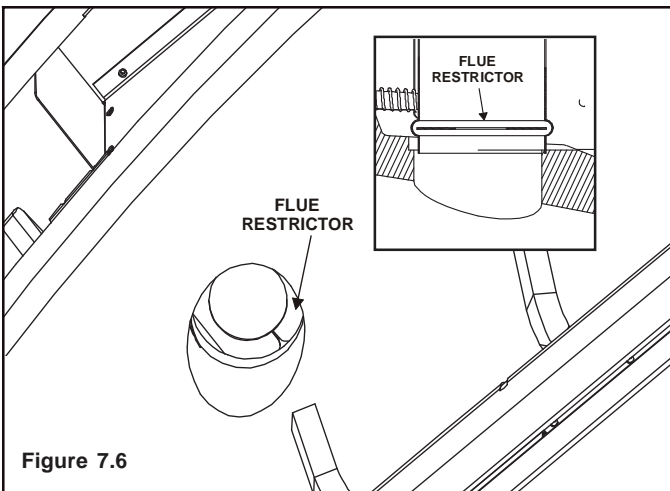

Figure 7.6

### E. Adjusting Pilot Shield

**Note:** When venting this unit with high vertical (10 feet or more) with very little horizontal the pilot shield will need to be in the closed position (see Figure 7.7).

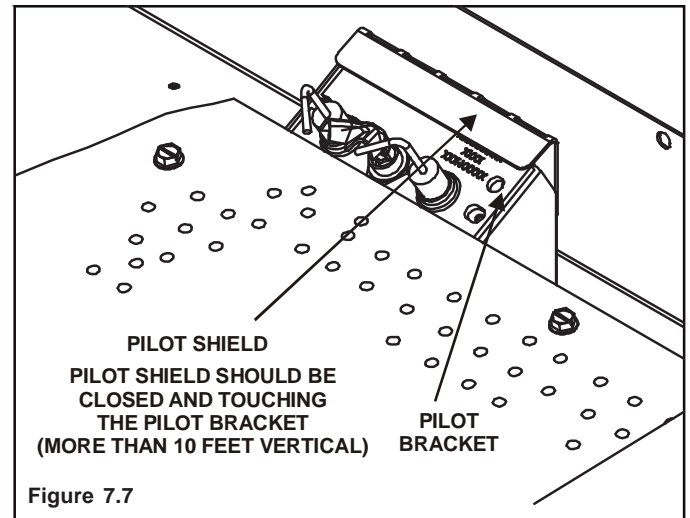

Figure 7.7

**Note:** When venting this unit with long horizontal runs and/or multiple elbows, the pilot shield will need to be in the opened position (see Figure 7.8).

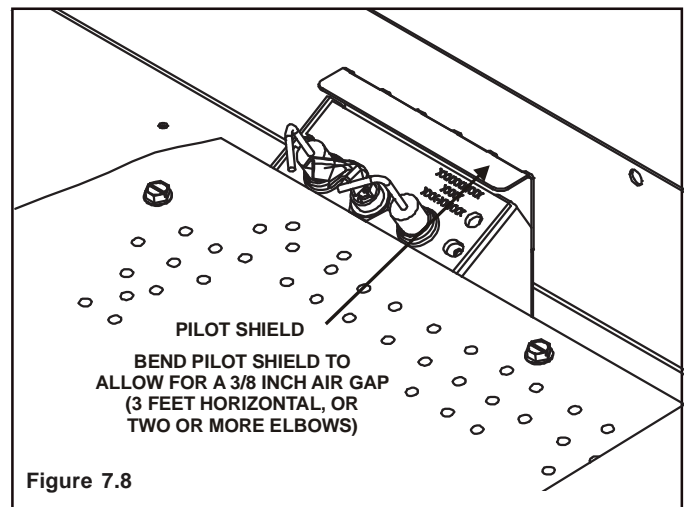



Figure 7.8

# 8

## Installing Vent Pipe

### A. Assembly of Vent Sections

	<b>WARNING</b>	
	Fire Risk Exhaust Fumes Risk Impaired Performance of Appliance	
	<ul style="list-style-type: none"><li>• Overlap pipe slip sections at least 1-1/2 inches.</li><li>• Use pilot holes for screws.</li><li>• Screws must not exceed one inch long.</li><li>• Pipe may separate if not properly joined.</li></ul>	

Make sure that the fiberglass rope ring supplied in the manual bag seals between the first vent component and the outer appliance wrap (see Figure 8.1).

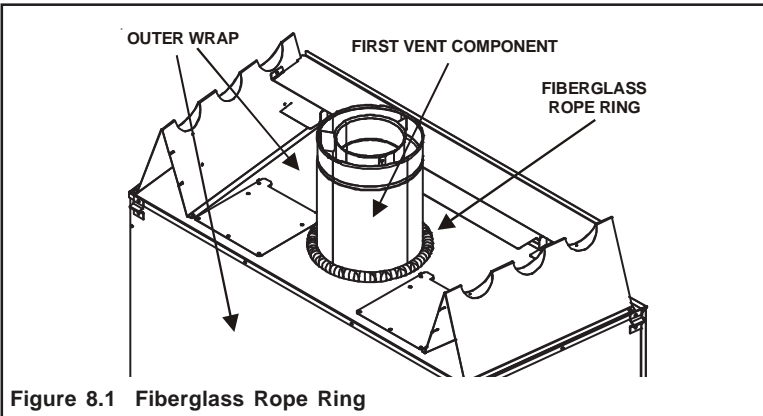

Figure 8.1 Fiberglass Rope Ring

#### Attaching Vent to the Firebox Assembly

To attach the first pipe section to the collars, slide the male end of the inner vent of the pipe section over the inner collar on the firebox assembly. At the same time, slide the outer flue over the outer collar on the appliance. Push the pipe section into the appliance collar until all the lances (Figure 8.2) have snapped in place. Tug slightly on the section to confirm it has completely locked into place. It is acceptable to use screws no longer than 1 inch to hold outer pipe sections together. If predrilling holes, do NOT penetrate inner pipe.

#### Assembling Pipe Sections

Insert the inner flue of section A into the flared inner flue of section B.

Start the outer flue of section A over the outer flue of section B (see Figure 8.3). **Note:** The end of the pipe sections with the lances/tabs on it will face towards the appliance.

Once both inner and outer flues are started, press section A onto section B firmly until all lances have snapped into place. Check to

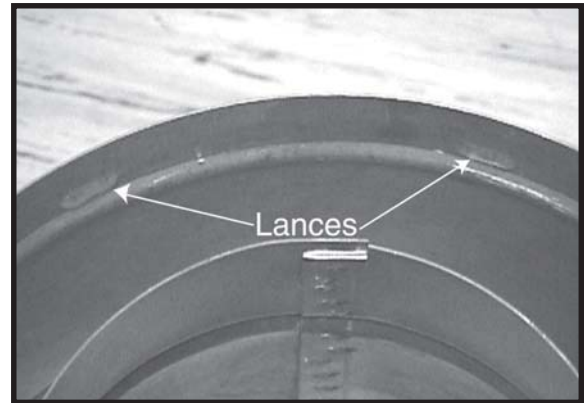

Figure 8.2 Lances

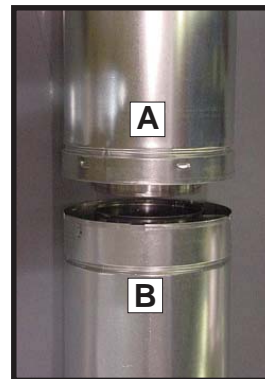

Figure 8.3



Figure 8.4

**Note:** Make sure that the seams are not aligned to prevent unintentional disconnection.

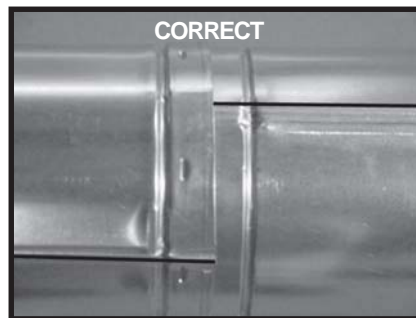
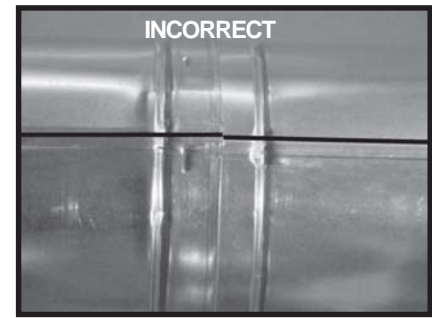

Figure 8.5 Seams



make sure they have snapped together (see Figure 8.4) and the seams are not aligned (see Figure 8.5). Tug slightly on section A to confirm it has completely locked into place.

For 90° and 45° elbows that are changing the vent direction from horizontal to vertical, one screw minimum should be put in the outer flue at the horizontal elbow joint to prevent the elbow from rotating. Use screws no longer than 1 inch. If predrilling screw holes, do NOT penetrate inner pipe.

### Assembling Minimum Installations (MI) Sections

MI sections are non-unitized so that they can be cut to a certain length. Cut these sections to length from the non-expanded end (see Figure 8.6).

They can then be attached by first connecting the expanded end of the MI inner flue with the inner pipe from the adjacent pipe section and securing with three screws. The expanded portion of the MI inner flue must overlap completely with the unexpanded end of the adjacent pipe section.

The outer flue can then be inserted into the adjacent outer flue expanded end and attached to the next pipe section with three screws. The other end of the MI pipe section can then be attached by fitting another pipe section to it and snapping it together, as normal.

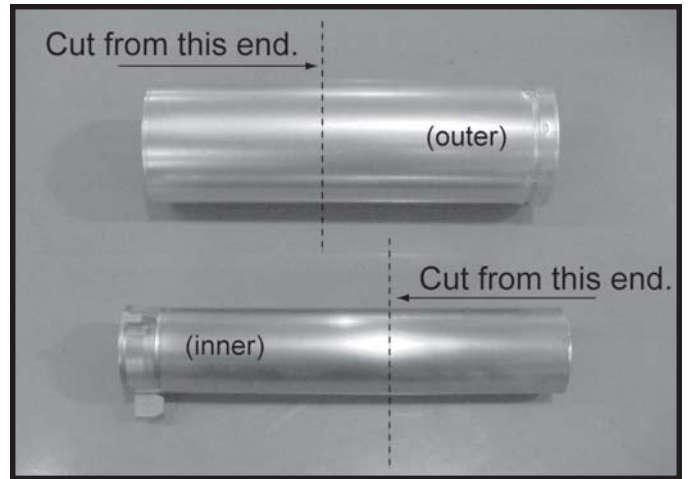

Figure 8.6

### Assembling DVP-12A Slip Sections

The outer flue of the slip section should slide over the outer flue of the pipe section and into (inner flue) the last pipe section (see Figure 8.7).

Slide together to the desired length, making sure that a 1-1/2 inch outer flue overlap is maintained between the pipe section and slip section.

The pipe and slip section need to be secured by driving two screws through the overlapping portions of the outer flues using the pilot holes (see Figure 8.8).

This will secure the slip section to the desired length and prevent it from separating. The slip section can then be attached to the next pipe section.

If the slip section is too long, the inner and outer flues of the slip section can be cut to the desired length.

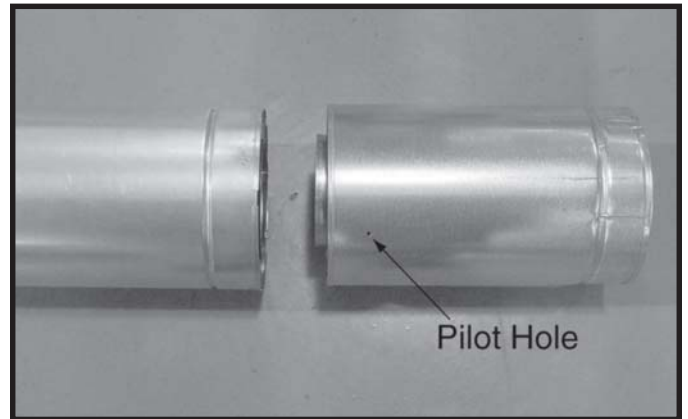

Figure 8.7 Slip Section Pilot Holes

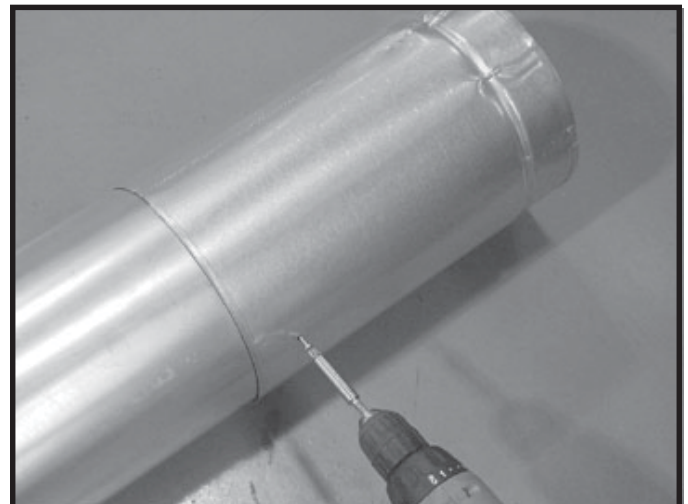

Figure 8.8 Screws into Slip Section

## Securing the Vent Sections

### Vertical Sections

Vertical sections of pipe must be supported every 8 feet after the 25 foot maximum unsupported rise. The vent support or plumber's strap (spaced 120° apart) may be used to do this (see Figure 8.9).

### Horizontal Sections

Horizontal sections of vent must be supported every 5 feet with a vent support or plumber's strap.

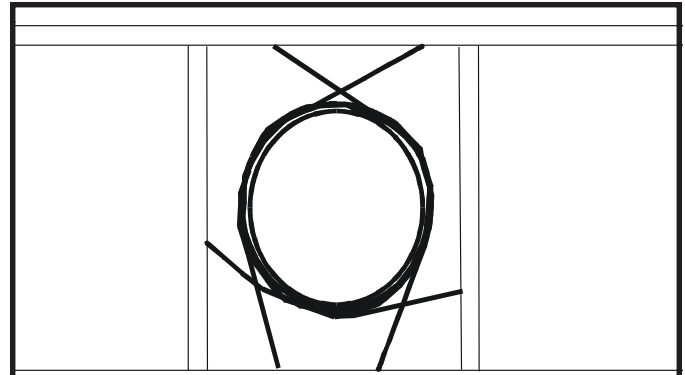

Figure 8.9 Securing Vertical Pipe Sections

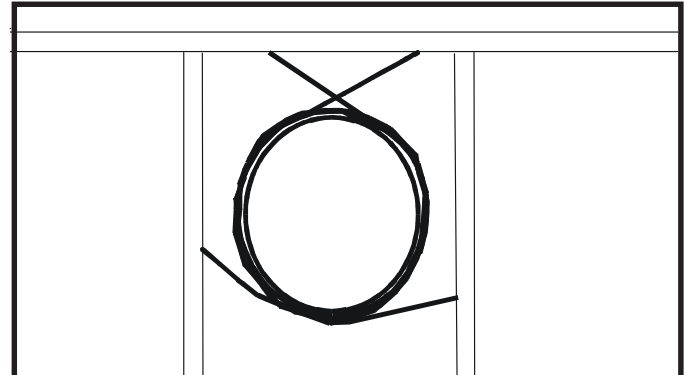





Figure 8.10 Securing Horizontal Pipe Sections

## B. Disassembly of Vent Sections

To disassemble any two pieces of pipe, rotate either section (see Figure 8.11), so that the seams on both pipe sections are aligned (see Figure 8.12). They can then be carefully pulled apart.

 <b>WARNING</b>	
	Fire Risk. Explosion Risk. Combustion Fume Risk.
	Use vent run supports per installation instructions. Connect vent sections per installation instructions.
	<ul style="list-style-type: none"><li>• Maintain all clearances to combustibles.</li><li>• Do NOT allow vent to sag below connection point to appliance.</li></ul>
Improper support may allow vent to sag or separate.	

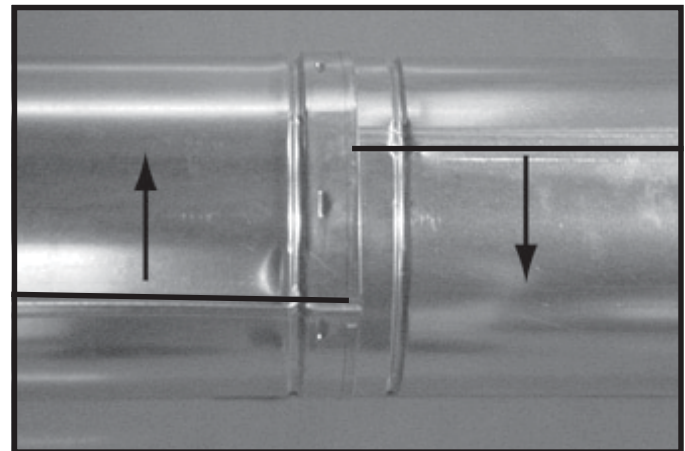

Figure 8.11 Rotate Seams for Disassembly

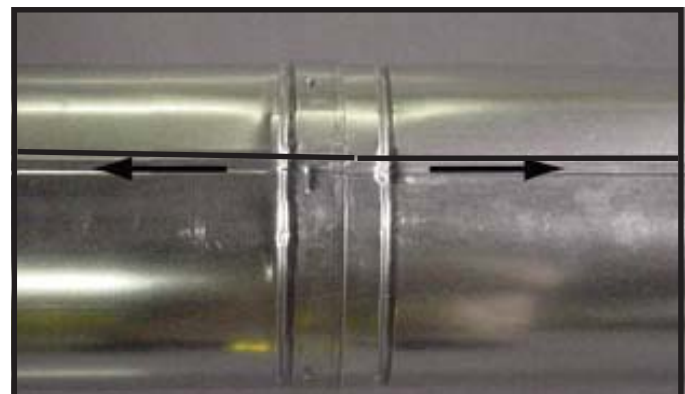





Figure 8.12 Align and Disassemble Vent Sections

## C. Installing Heat Shield and Horizontal Termination Cap

	<b>WARNING</b>
	<p>Fire Hazard</p> <p>Impaired performance of appliance</p> <ul style="list-style-type: none"> <li>Telescoping flue section of termination cap <b>MUST</b> be used when connecting pipe section to termination cap.</li> <li>Maintain a 1-1/2 inch minimum overlap on telescoping flue section of termination cap.</li> </ul>

	<b>WARNING</b>
	<p>Fire Risk</p> <p>Exhaust Fumes Risk</p> <p>Impaired Performance of Appliance</p> <ul style="list-style-type: none"> <li>Overlap pipe slip sections at least 1-1/2 inches.</li> <li>Use pilot holes for screws.</li> <li>Screws must not exceed 1 inch long.</li> <li>Pipe may separate if not properly joined.</li> </ul>

### Heat Shield Requirements for Horizontal Termination

For all horizontally vented appliances, a heat shield **MUST** be placed one inch above the top of the vent between the wall shield firestop and the base of the termination cap.

There are two sections of the heat shield. One section attaches to the wall shield firestop with two screws. The remaining section is attached to the cap in the same manner.

If the wall thickness does not allow the required 1-1/2 inch heat shield overlap, an extended heat shield must be used.

The extended heat shield will need to be cut to the thickness of the wall and be attached to the wall shield firestop. The small leg on the extended heat shield should rest on the top of the vent (pipe section) to properly space it from the pipe section (see Figure 8.13).

### Installing the Horizontal Termination Cap

Vent termination must not be recessed in the wall. Siding may be brought to the edge of the cap base.

Flash and seal as appropriate for siding material at outside edges of cap.

When installing a horizontal termination cap, follow the cap location guidelines as prescribed by current **ANSI Z223.1** and **CAN/CGA-B149** installation codes.

	<b>WARNING</b>
	<p>Burn Risk</p> <ul style="list-style-type: none"> <li>Local codes may require installation of a cap shield to prevent anything or anyone from touching the hot cap.</li> </ul>

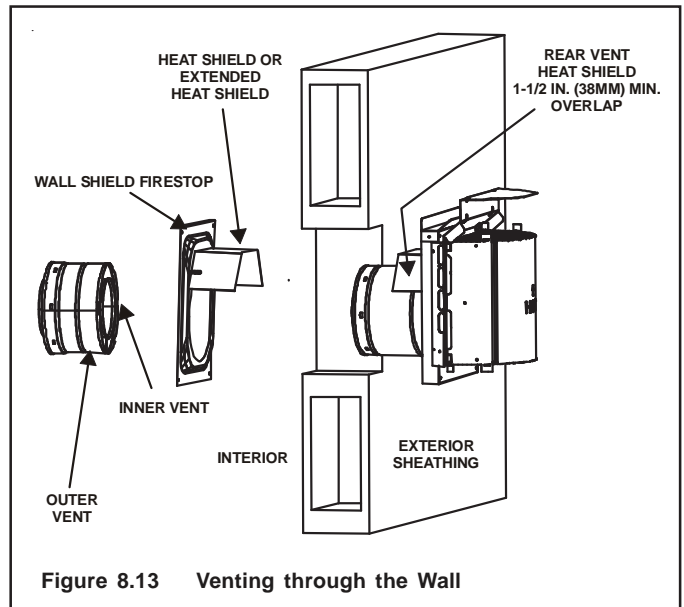

Figure 8.13 Venting through the Wall

**NOTE:** Where required, an exterior wall flashing is available.

When penetrating a brick wall, a brick extension kit is available for framing the brick.



## D. Installing Roof Flashing and Vertical Termination Cap

To install roof flashing see Figure 8.14.

For installation of vertical termination cap see minimum vent heights for various pitched roofs (see Figure 8.14).

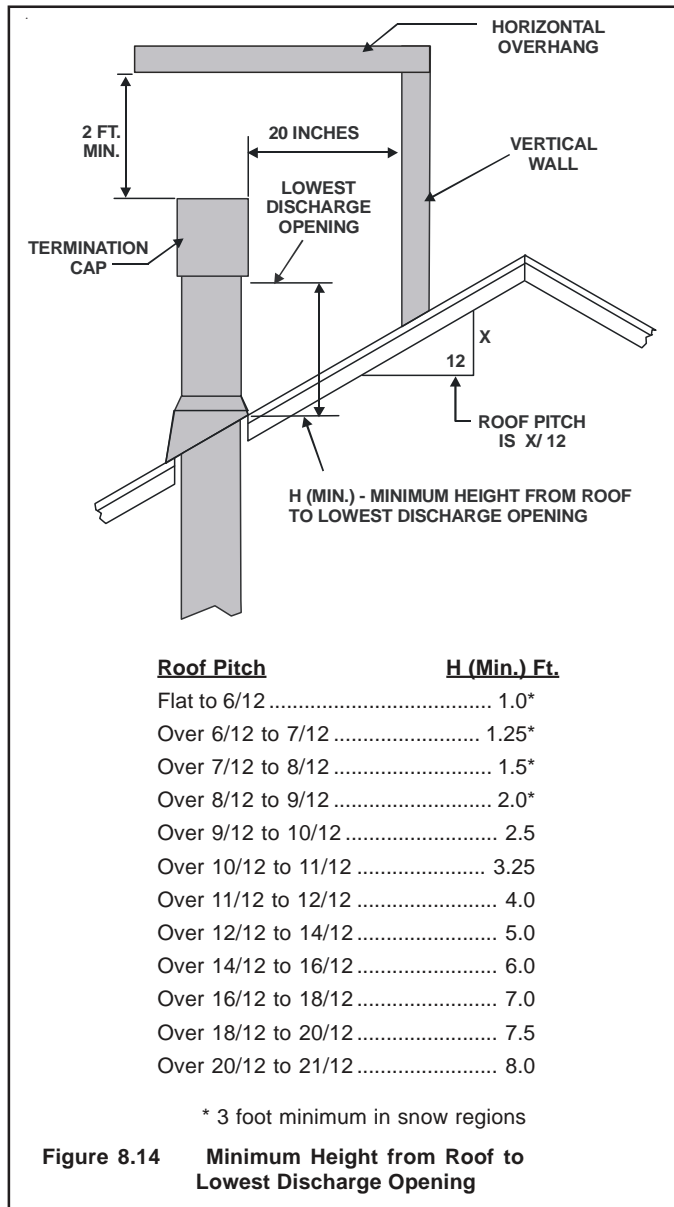

To attach the vertical termination cap, slide the inner collar of the cap into the inner flue of the pipe section and place the outer collar of the cap over the outer flue of the pipe section.

Secure the cap by driving the three self-tapping screws (supplied) through the pilot holes in the outer collar of the cap into the outer flue of the pipe (see Figure 8.15).



**Figure 8.15**

**⚠ WARNING**

Fire Risk.  
Explosion Risk.  
Inspect external vent cap regularly.

- Ensure no debris blocks cap.
- Combustible materials blocking cap may ignite.
- Restricted air flow affects burner operation.

## Assembling and Installing Storm Collar

	<b>CAUTION</b>	
	Sharp Edges	

- Wear protective gloves and safety glasses during installation.

Connect both halves of the storm collar with two screws (see Figure 8.16).

Wrap the storm collar around the exposed pipe section and align brackets. Insert a bolt (provided) through the brackets and tighten nut to complete storm collar assembly (see Figure 8.17).

Slide the assembled storm collar down the pipe section until it rests on the roof flashing.

Caulk around the top of the storm collar (see Figure 8.15).

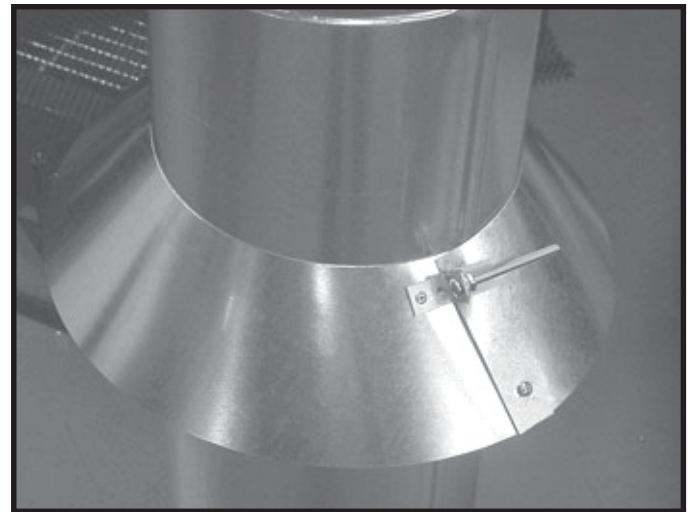

Figure 8.17 Assembling the Storm Collar Around the Pipe

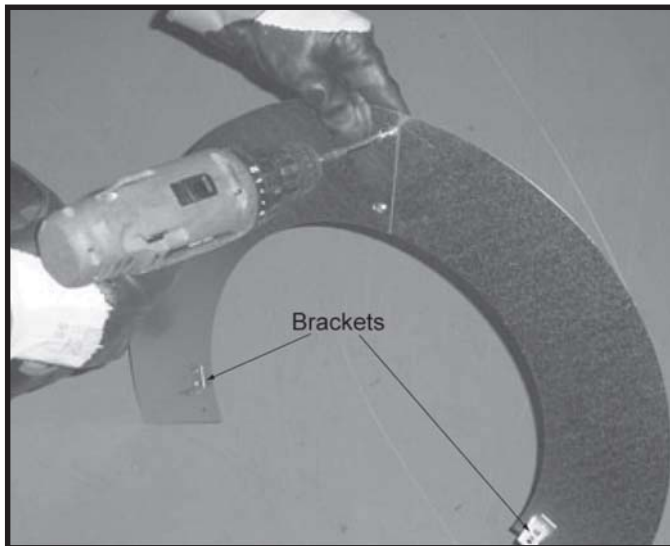

Figure 8.16 Assembling the Storm Collar

# 9

## Gas Information

### A. Fuel Conversions

Before making gas connections ensure that appliance being installed is compatible with the available gas type.

Any natural or propane gas conversions necessary to meet the appliance and locality needs must be made by a qualified technician using Hearth & Home Technologies specified and approved parts.

### B. Gas Pressures

Proper input pressures are required for optimum appliance performance. Gas line sizing requirements need to be made following NFPA51.

 **WARNING**



Fire Risk.  
Explosion Hazard.  
High pressure will damage valve.

- Disconnect gas supply piping **BEFORE** pressure testing gas line at test pressures above 1/2 psig.
- Close the manual shutoff valve **BEFORE** pressure testing gas line at test pressures equal to or less than 1/2 psig.

 **WARNING**



Verify inlet pressures.

- High pressure may cause overfire condition.
- Low pressure may cause explosion.
- Verify minimum pressures when other household gas appliances are operating.

Install regulator upstream of valve if line pressure is greater than 1/2 psig.

Pressure requirements for appliance are shown in the table below. Minimum pressures must be met when other household gas appliances are operating.

Pressure	Natural Gas	Propane
Minimum Inlet Pressure	5.0 inches w.c.	11.0 inches w.c.
Maximum Inlet Gas Pressure	14.0 inches w.c.	14.0 inches w.c.
Manifold Pressure	3.5 inches w.c.	10.0 inches w.c.

### C. Gas Connection

**NOTE:** Have the gas supply line installed in accordance with local building codes, if any. If not, follow ANSI 223.1. Installation should be done by a qualified installer approved and/or licensed as required by the locality. (In the Commonwealth of Massachusetts installation must be performed by a licensed plumber or gas fitter.)

**NOTE:** A listed (and Commonwealth of Massachusetts approved) 1/2 inch (13mm) T-handle manual shut-off valve and flexible gas connector are connected to the 1/2 inch (13mm) control valve inlet.

- **If substituting for these components, please consult local codes for compliance.**

Refer to **Reference Section 16** for location of gas line access in appliance.

**NOTE:** Gas line may be run from either side or bottom of the appliance provided the hole in the outer wrap does NOT exceed 2-1/2 inches in diameter and does not penetrate the firebox.

 **WARNING**





Gas Leak Risk



- Support control when attaching pipe to prevent bending gas line.



**NOTE:** The gap between the supply piping and gas access hole may be caulked with high temperature caulk or stuffed with non-combustible, un-faced insulation to prevent cold air infiltration.

- Ensure that gas line does not come in contact with outer wrap of appliance. Follow local codes.
- Incoming gas line should be piped into the valve compartment and connected to the 1/2 inch connection on the manual shutoff valve.

 <b>WARNING</b>	
	<b>Fire or Explosion Hazard</b>
	<ul style="list-style-type: none"> <li>• Gas buildup during line purge may ignite.</li> <li>• Purge should be performed by qualified technician.</li> <li>• Ensure adequate ventilation.</li> <li>• Ensure there are no ignition sources such as sparks or open flames.</li> </ul>

- A small amount of air will be in the gas supply lines. When first lighting appliance it will take a short time for air to purge from lines. When purging is complete the appliance will light and operate normally.

 <b>WARNING</b>	
	<b>CHECK FOR GAS LEAKS</b>
	<p>Explosion Risk Fire Risk Asphyxiation Risk</p> <ul style="list-style-type: none"> <li>• Check all fittings and connections.</li> <li>• Do not use open flame.</li> <li>• After the gas line installation is complete, all connections must be tightened and checked for leaks with a commercially-available, non-corrosive leak check solution. Be sure to rinse off all leak check solution following testing.</li> </ul> <p>Fittings and connections may have loosened during shipping and handling.</p>

 <b>WARNING</b>	
	<b>Fire hazard.</b>
	<p>Do NOT change the valve settings.</p> <ul style="list-style-type: none"> <li>• This valve has been preset at the factory.</li> <li>• Changing valve settings may result in fire hazard or bodily injury.</li> </ul>

## HIGH ALTITUDE INSTALLATIONS

U.L. Listed gas appliances are tested and approved without requiring changes for elevations from 0 to 2000 feet in the U.S.A. and Canada.

When installing this appliance at an elevation above 2000 feet, it may be necessary to decrease the input rating by changing the existing burner orifice to a smaller size. Input rate should be reduced by 4% for each 1000 feet above a 2000 foot elevation in the U.S.A., or 10% for elevations between 2000 and 4500 feet in Canada. If the heating value of the gas has been reduced, these rules do not apply. To identify the proper orifice size, check with the local gas utility.

If installing this appliance at an elevation above 4500 feet (in Canada), check with local authorities.

# 10



## Electrical Information

### A. Recommendation for Wire

This appliance requires 110-120 VAC be wired to the junction box for proper operation of the appliance. This appliance uses an Intellifire ignition system.

**NOTE:** This appliance must be electrically wired and grounded in accordance with local codes or, in the absence of local codes, with **National Electric Code ANSI/NFPA 70-latest edition** or the **Canadian Electric Code, CSA C221.1**.

### B. Connecting to the Appliance

	 <b>WARNING</b>
	Wire 110V to electrical junction box. Do NOT wire 110V to valve. Do NOT wire 110V to wall switch. <ul style="list-style-type: none"><li>• Incorrect wiring will damage millivolt valves.</li><li>• Incorrect wiring will override IPI safety lockout and may cause explosion.</li></ul>

- This appliance includes the WSK-MLT wall control. It requires the installation of a wall switch, to be connected to this appliance. Please reference the WSK-MLT instructions for specific installation and operating instructions.
- Use the wire provided with this product to connect the wall switch with the receiver control, as outlined in the instructions for the WSK-MLT control.
- Keep wire lengths short as possible by removing any excess wire length.
- Low voltage and 110 VAC voltage cannot be shared within the same wall box.

### C. Intellifire Ignition System Wiring

This appliance requires a 110 VAC supply to the appliance junction box for operation. A wiring diagram is shown in Figure 10.1.

This appliance is equipped with an Intellifire control valve which operates on a 3 volt system. This appliance is supplied with a battery pack which requires two D cell batteries (not included).

#### CAUTION



Battery polarity must be correct or module damage will occur.

#### Optional Accessories Requirements

Wiring for optional accessories should be done now to avoid reconstruction.

#### CAUTION

Label all wires prior to disconnection when servicing controls. Wiring errors can cause improper and dangerous operation. Verify proper operation after servicing.

	 <b>WARNING</b>
	Shock hazard. <ul style="list-style-type: none"><li>• Replace damaged wire with type 105° C rated wire.</li><li>• Wire must have high temperature insulation.</li></ul>

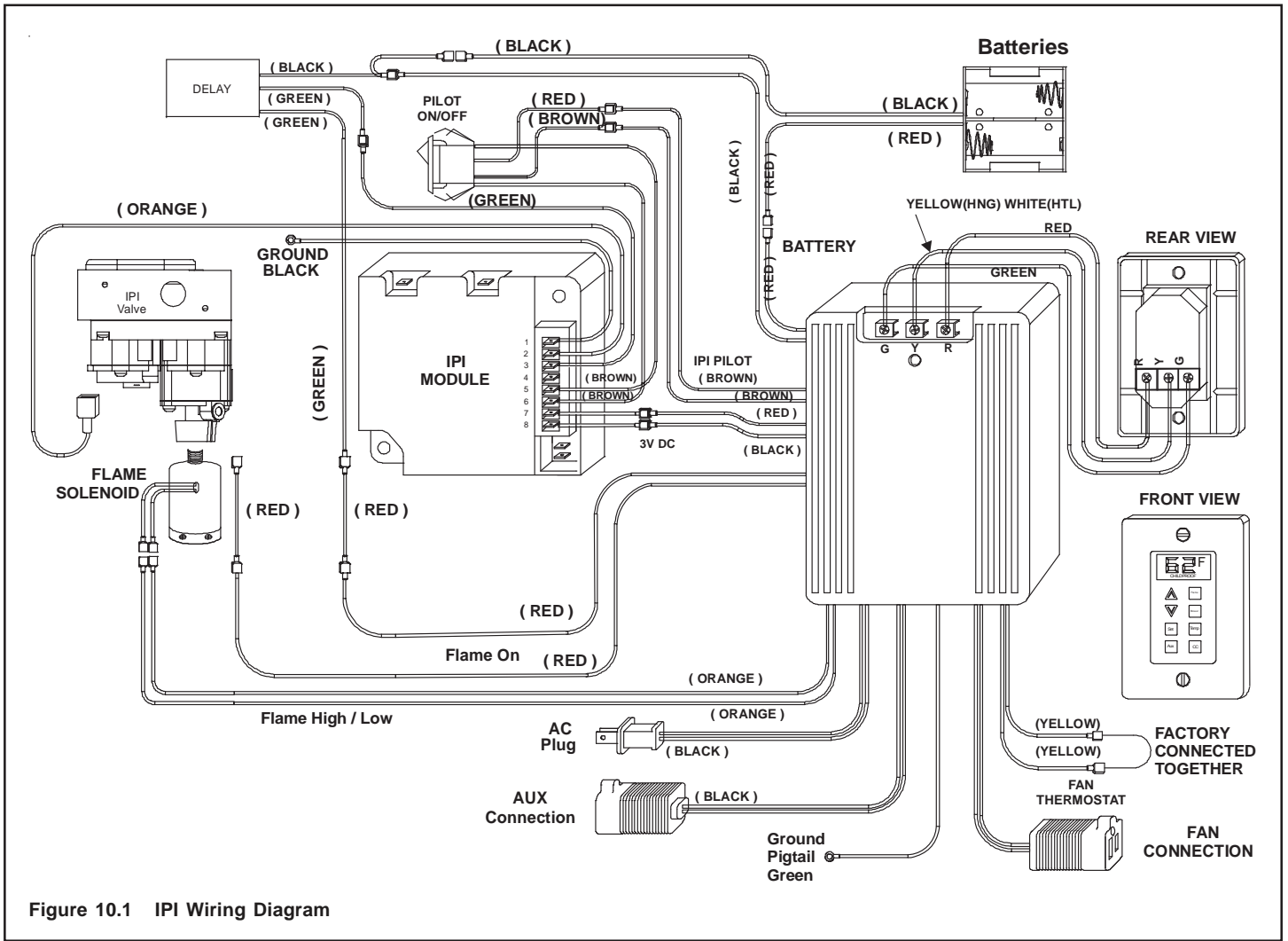

Figure 10.1 IPI Wiring Diagram

## D. Junction Box Installation

If the box is being wired from the **OUTSIDE** of the appliance:

- Loosen two screws on the Romex connector, feed the necessary length of wire through the connector and tighten the screws.
- Make all necessary wire connections and reattach the cover plate to the outer shell.

If the box is being wired from the **INSIDE** of the appliance:

- Remove the screw attaching the junction box to the outer shell, rotate the junction box inward to disengage it from the outer shell (see Figure 10.2).
- Loosen the two screws on the Romex connector, feed the necessary length of wire through the connector and tighten the screws.
- Pull the electrical wires from outside the appliance through this opening into the valve compartment.
- Make all necessary wire connections to the receptacle and assemble the receptacle and cover to the junction box.

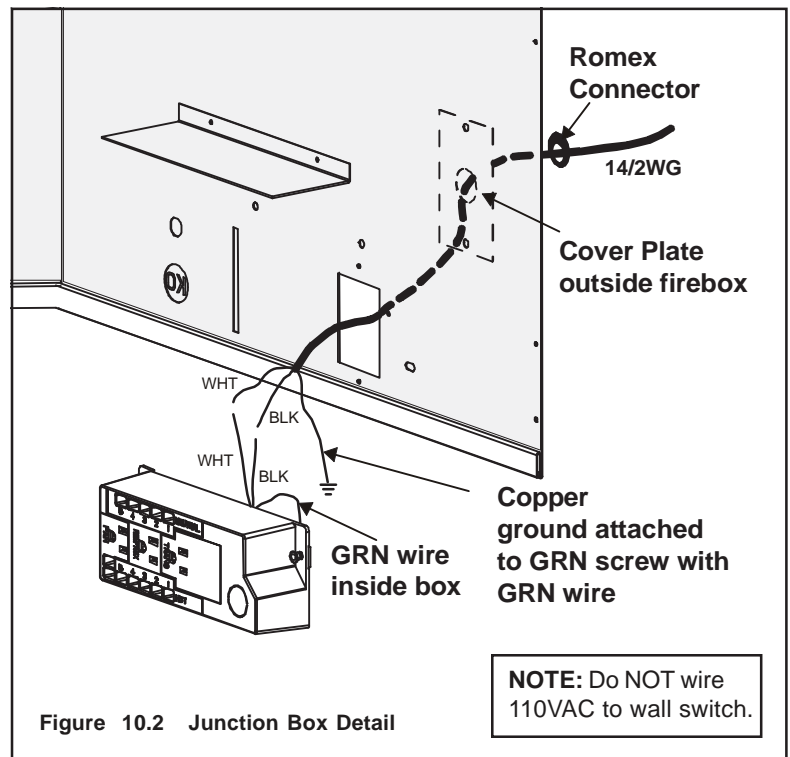

# 11

## Finishing

### A. Mantel Projections

Figure 11.1 shows the minimum vertical and corresponding maximum horizontal dimensions of appliance mantels or other combustible projections above the top front edge of the appliance.

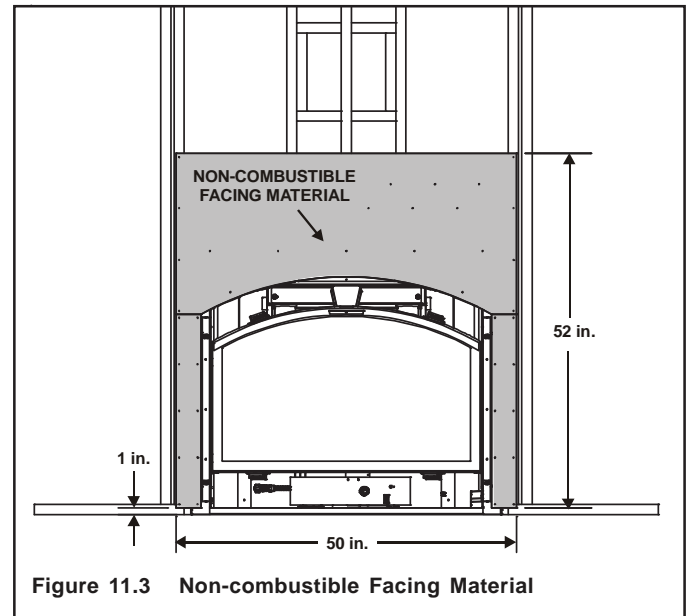
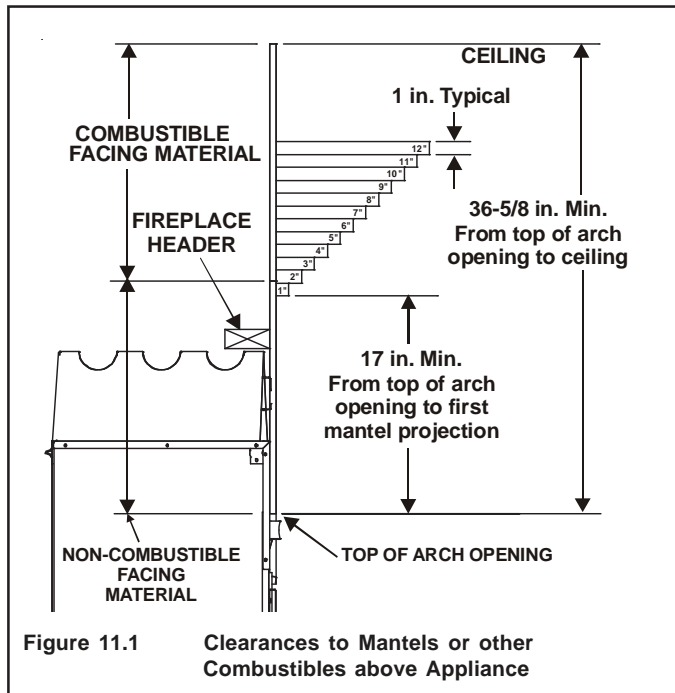

**WARNING**

**Risk of Fire**

- Non-combustible clearances must be maintained.
- Sheetrock, wood or other combustibles must NOT be used as sheathing or facing in the non-combustible zone.
- See **Section 11** for proper clearances.
- See **Section 1** for combustible/non-combustible definitions.

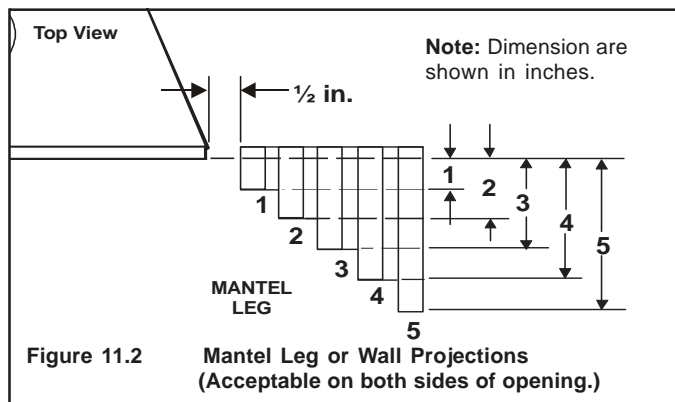

### B. Facing Material

**WARNING**

**Fire Risk.**

Do NOT obstruct air inlet or outlet grilles.  
Do NOT modify grilles.

- Modifying or covering grilles could cause temperature rise and fire hazard.

Finishing materials must not interfere with:

- Air flow through grilles or louvers.
- Operation of louvers or doors.
- Access for service.

**WARNING**

**Fire Risk.**

Finish all edges and fronts to clearances and specifications listed in manual.

- Black metal appliance front may be covered with noncombustible material only.
- Do NOT overlap combustible materials onto appliance front.
- Install combustible materials up to specified clearances on top front and side edges.
- Seal joints between the finished wall and appliance top and sides using only a high temperature sealant or stove cement.



## → C. Finishing Material Requirements

### Finishing Material Thickness from 3/4 inch to 1-1/4 inch

Finishing material within this thickness range can be brought to 1/2 inch behind the door top and sides. These non-combustible finishing materials must never overlap or obstruct the air outlet/inlet grille areas.

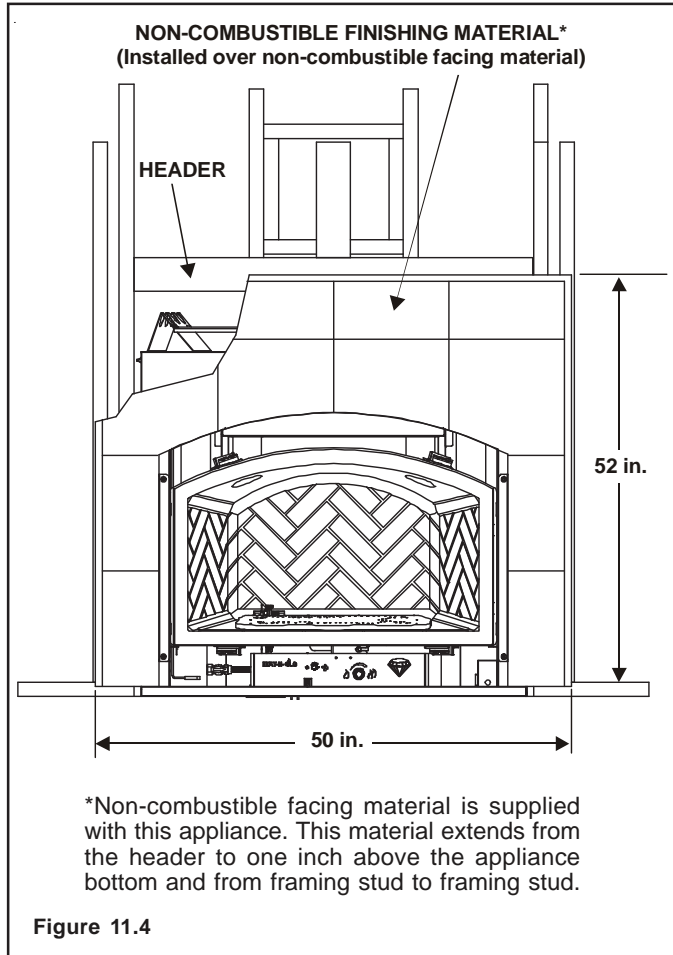

### **IMPORTANT INSTALLATION NOTE**

Please note that there are four holes or dots on the template to assist in positioning the template. These holes or dots should line up with the door mounting holes on the unit to ensure proper placement of the door after finishing materials are installed.

## Finishing Material Thickness greater than 1-1/4 inch ←

For finishing material greater than 1-1/4 inch a template should be constructed to provide the finishers with a guide to leave a 1/8 inch gap between the finishing materials and the door. See Figure 11.5 to construct the facing template. A steel template (GEM42-Template) is available for purchase ← to use instead of constructing a template.

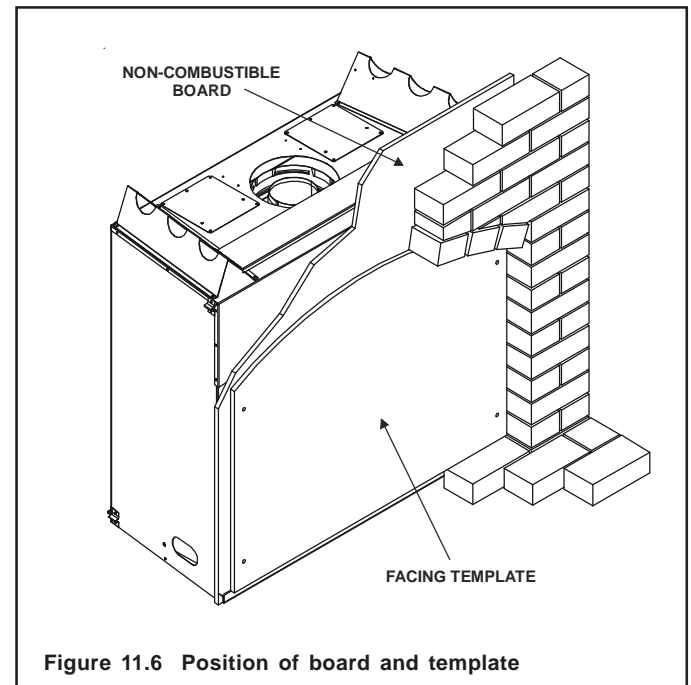
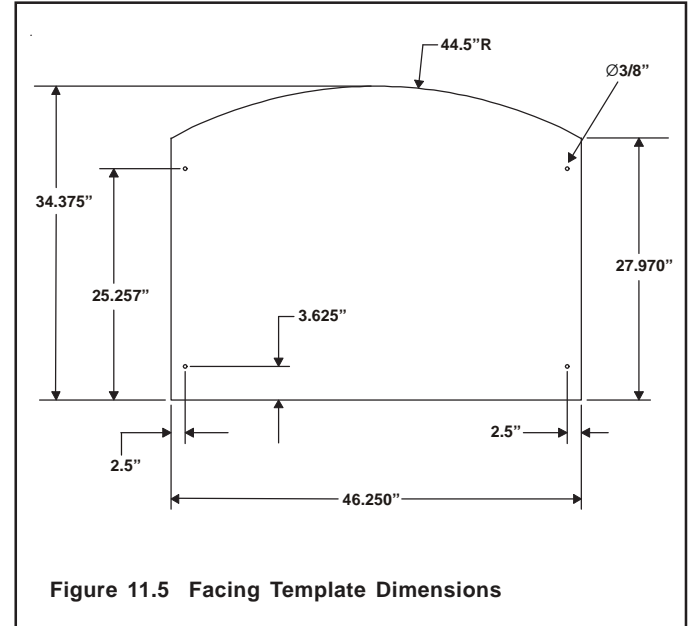

## D. Hearth Extension



### **WARNING**

Fire Risk.

Hearth extension required to protect combustible floors in front of appliance.

- An 8 inch minimum hearth extension must be constructed of non-combustible material.

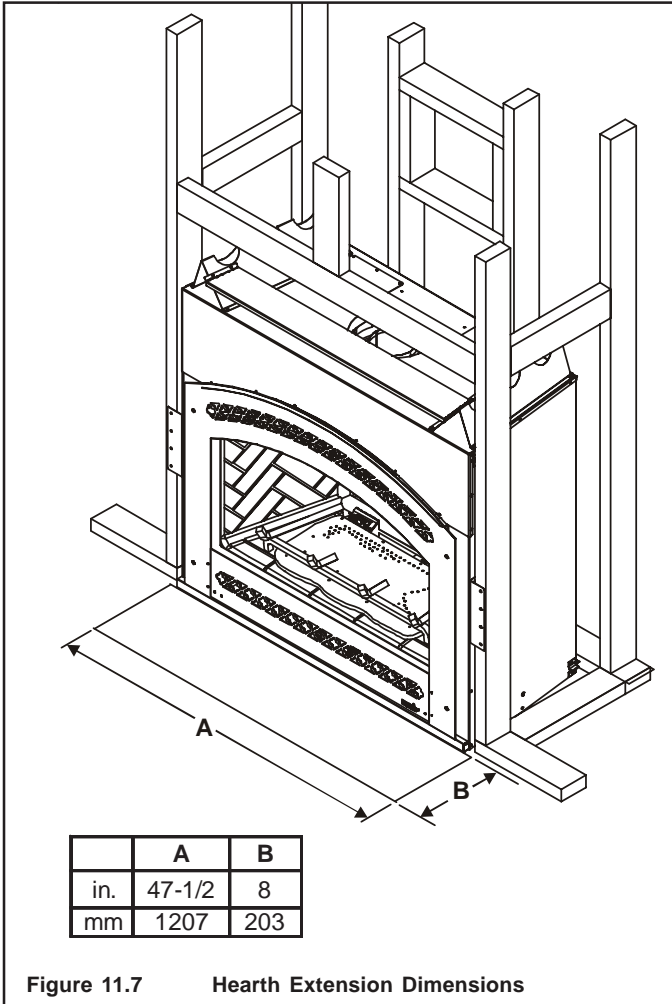

# 12

## Appliance Setup

### A. Remove Shipping Materials

Remove shipping materials from inside or underneath the firebox.

### B. Clean the Appliance

Clean/vacuum any sawdust that may have accumulated inside the firebox or underneath in the control cavity.

### C. Accessories

Install approved accessories per instructions included with accessories. See Service Parts List for appropriate accessories. Refer to **Section 16**.

#### Heat-Out Kit

- Remove the Heat-Out knockout from the appliance and discard it (see Figure 12.1).
- Center the rear collar around the exposed hole and attach it to the appliance with 3 screws.

**NOTE:** Remove the bottom knockout on the collar for typical 2 x 4 inch or 2 x 6 inch wall construction (see Figure 12.1).

- Cut and frame a 12 inch wide x 10 inch tall (305 x 254mm) hole in the exterior wall. The center of the hole will be 22-15/16 inch (583mm) above the base of the appliance (see Figure 6.2).
- Install the interior firestop with the hole towards the top. Secure the firestop to wall framing members.
- Reference the Heat-Out kit instructions for the remaining installation steps.

**NOTE:** There must be **NO INSULATION** or other combustibles inside the framed firestop opening.

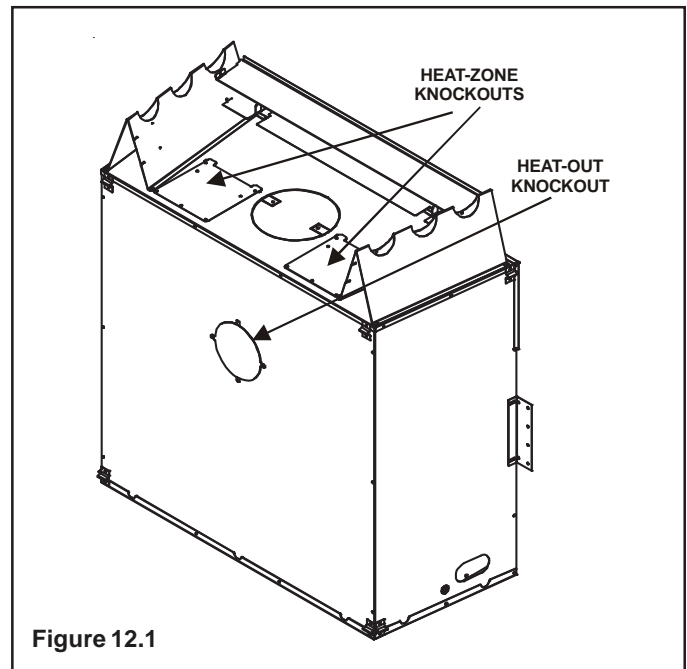

Figure 12.1

#### Heat-Zone Kit



- Remove the knockout from the top of the appliance and discard it (see Figure 12.1).

**NOTE:** Center the duct collar around the exposed hole and attach it to the appliance with 3 screws **BEFORE** final positioning of the appliance.

- Determine the location for the air register/fan housing assembly.
- Reference the Heat-Zone kit instructions for the remaining installation steps.

	<b>WARNING</b>
	Shock or fire risk. Use <b>ONLY</b> optional accessories approved for this appliance. <ul style="list-style-type: none"><li>• Using non-listed accessories voids warranty.</li><li>• Using non-listed accessories may result in a safety hazard.</li><li>• Only Hearth &amp; Home Technologies approved accessories may be used safely.</li></ul>

## D. Ember Placement

 <b>WARNING</b>	
	<p>Explosion Risk.</p> <ul style="list-style-type: none"><li>• Follow ember placement instructions in manual.</li><li>• Do NOT place embers directly over burner ports.</li><li>• Replace ember material annually.</li></ul> <p>Improperly placed embers interferes with proper burner operation.</p>

### Placing the Ember Material

Ember material is shipped with this gas appliance. To place the ember material:

- There are two types of embers shipped with the unit. Embers for the burner surface and Mystic Embers for the floor of the unit.
- Embers CANNOT be placed directly over ports. Care should be taken not to cover the lighting trail of ports (from back to front).
- When placing Glowing Embers® onto the burner care should be taken so that the ports are not covered. Place the dime-size ember pieces just in front of the port trail, but not on or in between the ports. For best performance do NOT place embers on the ports at the rear of the burner. Failure to follow procedure will likely cause lighting and sooting problems.
- Place Mystic Embers on the floor of unit.
- Save the remaining ember materials for use during appliance servicing. The embers provided should be enough for 3 to 5 applications.

## E. Positioning the Logs

If the gas logs have been factory installed they should not need to be positioned. If the logs have been packaged separately, refer to the following instructions.

## Log Assembly: LOGS-GEM42

**CAUTION:** Carefully remove the logs from the packaging. Logs are fragile! Before proceeding be sure to remove and discard the foam shipping pads shown here.

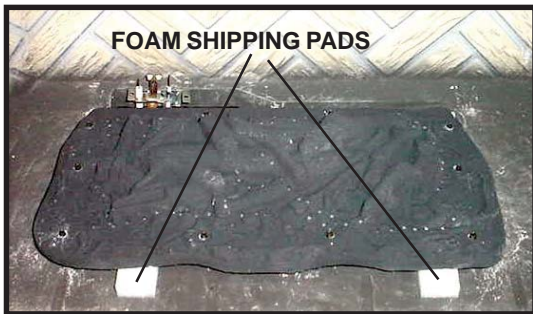

### STEP 1.

Remove grate which is shipped on top of fireplace. Position the log grate as shown. Use the grate locating tabs that are located at the back corners of the burner.

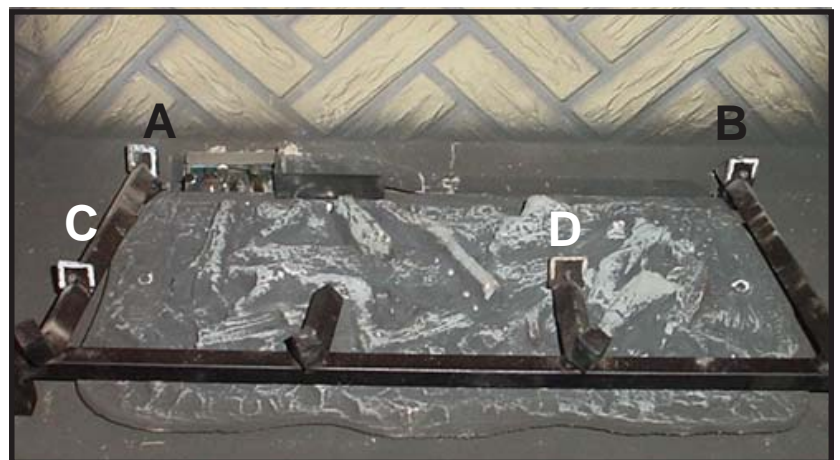

### STEP 2. LOG #1 (SRV371-700):

Position log #1 on the log grate by aligning the notches on the bottom of log #1 with tabs A and B as shown. The right side should be positioned so there is a gap between the log and burner.



### STEP 3. LOG #2 (SRV371-701):

Position log #2 on the log grate by aligning the notch located on the bottom of log #2 with tab D. The right side of the log should touch log #1 as shown.



### STEP 4. LOG #3 (SRV371-702):

Locate the notch on the underside of log #3. Mate the log notch with grate tab C. The front nose of log #3 should come into contact with the grate tine as shown.



### STEP 5. LOG #4 (SRV371-704):

Locate the notch on the underside of log #4. Place the log so that the notch fits onto the left tab on log #1. The log should rest on both log #1 and log #3.



**STEP 6. LOG #5 (SRV371-703):**

Locate the notch on the underside of log #5. Place the log so that the notch fits onto the right tab on log #1. Position the front end of log #5 so it rests on log #2 as shown.



**STEP 7. LOG #6 (SRV371-705):**

Position log #6 into the notch on log #4 as shown.



## F. Glass Assembly



### WARNING



Handle glass doors with care.

- Inspect the gasket to ensure it is undamaged.
- Inspect the glass for cracks, chips or scratches.

- Do NOT strike, slam or scratch glass.
- Do NOT operate appliance with glass door removed, cracked, broken or scratched.
- Replace glass door assembly as a complete appliance.

### Removing Glass Assembly

Pull the four glass assembly latches out of the groove on the glass frame. Remove glass door from the appliance (see Figure 12.2).

### Replacing Glass Assembly

Replace the glass door on the appliance. Pull out and latch the four glass assembly latches into the groove on the glass frame.

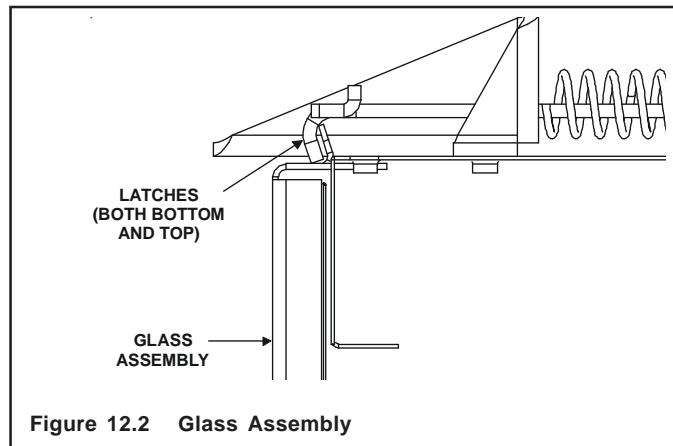

Figure 12.2 Glass Assembly

## G. Grilles and Trim

Install optional marble and brass trim surround kits as desired. Marble, brass, brick, tile, or other noncombustible materials can be used to cover up the gap between the sheet rock and the appliance.

Do not obstruct or modify the air inlet/outlet grilles. When overlapping on both sides, leave enough space so that the bottom grille can be lowered and the trim door removed.

## H. Air Shutter Setting

This appliance has an adjustable air shutter (which controls the primary air) factory set for the minimum vertical vent run (see Figure 12.3). If your installation has more than the minimum required vertical vent length, adjustment of the air shutter may be necessary to obtain optimal flame appearance. **This should be adjusted by a qualified installer at the time of installation.**

By pushing the air shutter handle in, you will be closing the air shutter. To adjust loosen the wing nut. Care should be taken when adjusting the air shutter so as not to cause the appliance to soot. If sooting occurs the air shutter will need to be opened by pulling the handle out.

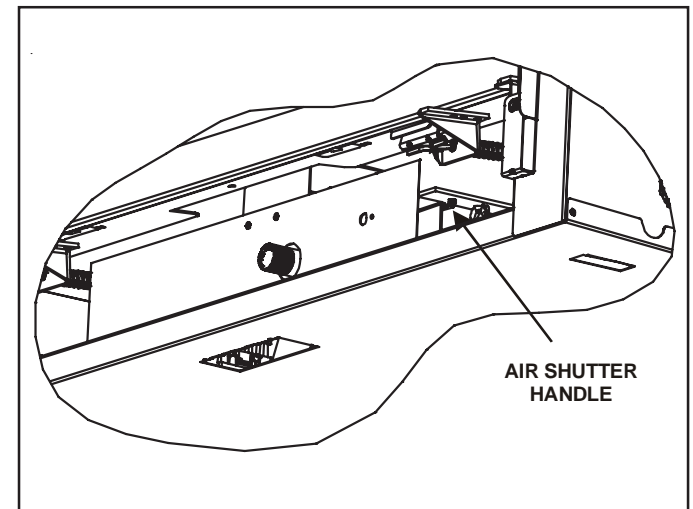

Figure 12.3

### Shutter Settings

	NG	LP
Burner	Full Open	Fixed



# 13

## Operating Instructions

### A. Before Lighting Appliance

Before lighting this appliance determine if it has a Standing Pilot or Intellifire ignition system by opening the control access panel to view wiring system and gas valve. If this appliance has a red or black ignitor button (see Figure 10.1) this appliance has a Standing Pilot ignition system. If there is no red or black ignitor button, this appliance has an Intellifire ignition system.

#### CAUTION

If installing Intellifire ignition battery backup:

- Do not install batteries if the backup mode may not be used for extended time.
- Batteries may leak.
- Install batteries only when needed for power outage.

**Before operating this appliance have a qualified technician:**

- Remove all shipping materials from inside and/or underneath the firebox.
- Review proper placement of logs and ember material.
- Check the wiring.
- Check the air shutter adjustment.
- Ensure that there are no gas leaks.
- Ensure that the glass is sealed and in the proper position.
- Ensure that the flow of combustion and ventilation air is not obstructed (front grilles and vent caps).



#### WARNING

Glass door must be in place when appliance is operating.

Risk of:

- Combustion Fumes
- Fire

Do NOT operate appliance with glass door removed.

- Open viewing glass for servicing only.
- Glass door MUST be in place and sealed before operating appliance.
- Only use glass door certified for use with appliance.
- Glass replacement should be done by qualified technician.



#### WARNING

**HOT! DO NOT TOUCH.  
SEVERE BURNS MAY RESULT.  
CLOTHING IGNITION MAY RESULT.**



Glass and other surfaces are hot during operation and cool down.

- Keep children away.
- CAREFULLY SUPERVISE children in same room as appliance.
- Alert children and adults to hazards of high temperatures.
- Do NOT operate with protective barriers open or removed.
- Keep clothing, furniture, draperies and other combustibles away.

***This appliance has been supplied with an integral barrier to prevent direct contact with the fixed glass panel. Do NOT operate the appliance with the protective barrier removed.***

Contact your dealer or Hearth & Home Technologies if the barrier is not present or help is needed to properly install one.

#### WARNING

Improper installation, adjustment, alteration, service or maintenance can cause injury or property damage. Refer to the owner's information manual provided with this appliance. For assistance or additional information consult a qualified installer, service agency or the gas supplier.

#### WARNING

Do NOT use this appliance if any part has been under water. Immediately call a qualified service technician to inspect the appliance and to replace any part of the control system and any gas control which has been under water.

## B. Lighting Appliance

### Intellifire Ignition

#### FOR YOUR SAFETY READ BEFORE LIGHTING

**WARNING:** If you do not follow these instructions exactly, a fire or explosion may result causing property damage, personal injury or loss of life.

- A.** This appliance is equipped with an electronic pilot ignition device which automatically lights the pilot. Do not try to light the pilot by hand.
- B. BEFORE LIGHTING,** smell all around the appliance area for gas. Be sure to smell next to the floor because some gas is heavier than air and will settle on the floor.
- WHAT TO DO IF YOU SMELL GAS**
- Do not try to light any appliance.
  - Do not touch any electric switch; do not use any phone in your building.
  - Immediately call your gas supplier from a neighbor's phone. Follow the gas supplier's instructions.
  - If you cannot reach your gas supplier, call the fire department.
- C.** Do not use this appliance if any part has been under water. Immediately call a qualified service technician to inspect the appliance and to replace any part of the control system and any gas control which has been under water.

#### WARNING:

##### DO NOT CONNECT 110 VAC TO THE CONTROL VALVE.

Improper installation, adjustment, alteration, service or maintenance can cause injury or property damage. Refer to the owner's information manual provided with this appliance.

This appliance needs fresh air for safe operation and must be installed so there are provisions for adequate combustion and ventilation air.

If not installed, operated, and maintained in accordance with the manufacturer's instructions, this product could expose you to substances in fuel or fuel combustion which are known to the State of California to cause cancer, birth defects, or other reproductive harm.

Keep burner and control compartment clean. See installation and operating instructions accompanying appliance.

For additional information on operating your Hearth Technologies appliance, please refer to [www.Fireplaces.com](http://www.Fireplaces.com).

#### CAUTION:

Hot while in operation. Do not touch. Keep children, clothing, furniture, gasoline and other liquids having flammable vapors away.

Do not operate the appliance with panel(s) removed, cracked or broken. Replacement of the panel(s) should be done by a licensed or qualified service person.

#### NOT FOR USE WITH SOLID FUEL

For use with natural gas and propane. A conversion kit, as supplied by the manufacturer, shall be used to convert this appliance to the alternate fuel.

#### Also Certified for Installation in a Bedroom or a Bedsitting Room.

For assistance or additional information, consult a qualified installer, service agency or the gas supplier.

#### LIGHTING INSTRUCTIONS

1. Turn off all electric power to the appliance.
2. This appliance is equipped with an electronic pilot ignition device which automatically lights the pilot. Do not try to light the pilot by hand.
3. Wait five (5) minutes to clear out any gas. Then smell for gas, including near the floor. If you smell gas, STOP! Follow "B" in the Safety Information located on the left side of this label. If you don't smell gas, go to next step.
4. Turn on all electric power to the appliance.
5. Push the Flame ON button.

Note: There will be a 3 minute delay before the burner will light.

6. If the appliance will not operate, follow the instructions "To Turn Off Gas to Appliance" and call your service technician or gas supplier.

Note: To operate pilot without the burner, push the pilot button.

#### TO TURN OFF GAS TO APPLIANCE

1. Turn off all electric power to the appliance if service is to be performed.
2. Flip both Pilot and Flame ON/OFF switches to the "OFF" position.

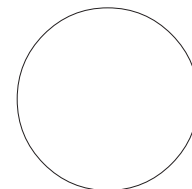

#### Final Inspection by \_\_\_\_\_

2095-913B

## C. After Appliance is Lit

### Initial Break-in Procedure

When you light the appliance, you may notice that it produces heat which does have an associated odor or smell. If you feel this odor is excessive it may require the initial three to four hour continuous burn on high followed by a second burn up to 12 hours to fully drive off any odor from paint and lubricants used in the manufacturing process. Condensation of the glass is normal.

**NOTE:** The appliance should be run three to four hours on the initial start-up. Turn it off and let it cool completely. Remove and clean the glass. Replace the glass and run the appliance for an additional 12 hours. This will help to cure the products used in the paint and logs.

During this break-in period it is recommended that some windows in the house be opened for air circulation. This will help avoid setting off smoke detectors, and help eliminate any odors associated with the appliance's initial burning.

	<b>⚠ WARNING</b>
	<p>Fire Risk. High Temperatures.</p> <p>Keep combustible household items away from appliance. Do NOT obstruct combustion and ventilation air.</p> <ul style="list-style-type: none"> <li>• Do NOT place combustible items on top of or in front of appliance.</li> <li>• Keep furniture, draperies away from appliance.</li> </ul>

<b>CAUTION</b>
<ul style="list-style-type: none"> <li>• Prevent accidental appliance operation when not attended.</li> <li>• Unplug or remove batteries from remote control if absent or if appliance will not be used for an extended period of time.</li> <li>• Property damage possible from elevated temperatures.</li> </ul>

<b>CAUTION</b>
<p>Smoke and odors released during initial operation.</p> <ul style="list-style-type: none"> <li>• Open windows for air circulation.</li> <li>• Leave room during initial operation.</li> <li>• Smoke may set off smoke detectors.</li> </ul> <p>Smoke and odors may be irritating to sensitive individuals.</p>

	<b>⚠ WARNING</b>
	<p>Fire Hazard. Keep combustible materials, gasoline and other flammable vapors and liquids clear of appliance.</p> <ul style="list-style-type: none"> <li>• Do NOT store flammable materials in the appliance's vicinity.</li> <li>• Do NOT use gasoline, lantern fuel, kerosene, charcoal lighter fluid or similar liquids in this appliance.</li> <li>• Combustible materials may ignite.</li> </ul>

## D. Frequently Asked Questions

ISSUE	SOLUTIONS
Condensation on the glass	This is a result of gas combustion and temperature variations. As the appliance warms, this condensation will disappear.
Blue flames	This is a result of normal operation and the flames will begin to yellow as the appliance is allowed to burn for 20 to 40 minutes.
Odor from appliance	When first operated, this appliance may release an odor for the first several hours. This is caused by the curing of the paint and the burning off of any oils remaining from manufacturing. Odor may also be released from finishing materials and adhesives used around the appliance.
Film on the glass	This is a normal result of the curing process of the paint and logs. Glass should be cleaned within 3 to 4 hours of initial burning to remove deposits left by oils from the manufacturing process. A non-abrasive cleaner such as gas fireplace glass cleaner may be necessary. See your dealer.
Metallic noise	Noise is caused by metal expanding and contracting as it heats up and cools down, similar to the sound produced by a furnace or heating duct. This noise does not affect the operation or longevity of the appliance.
Is it normal to see the pilot flame burn continually?	In an Intellifire ignition system it is normal to see the pilot flame, but it should turn off when ON/OFF is turned off. In a standing pilot system the pilot will always stay on.

# 14

## Troubleshooting

With proper installation, operation, and maintenance your gas appliance will provide years of trouble-free service. If you do experience a problem, this troubleshooting guide will assist a qualified service person in the diagnosis of a problem and the corrective action to be taken. This troubleshooting guide can only be used by a qualified service technician.

### A. Intellifire Ignition System

Symptom	Possible Causes	Corrective Actions
1. The ignitor/module makes noise, but no spark.	a. Incorrect wiring.	Verify "S" wire (white) for sensor and "I" wire (orange) for ignitor are connected to correct terminals on module and pilot assembly. Reversed wires at the module may cause system to make sparking noise, but spark may not be present at pilot hood.
	b. Loose connections or electrical shorts in the wiring.	Verify no loose connections or electrical shorts in wiring from module to pilot assembly. Rod closest to pilot hood should be ignitor. Verify connections underneath pilot assembly are tight; also verify connections are not grounding out to metal chassis, pilot burner, pilot enclosure, mesh screen if present, or any other metal object.
	c. Ignitor gap is too large.	Verify gap of igniter to pilot hood. The gap should be approximately .17 inch or 1/8 inch.
	d. Faulty module.	Turn ON/OFF rocker switch or wall switch to OFF position. Remove ignitor wire "I" from module. Place ON/OFF Rocker switch or wall switch in ON position. Hold ground wire about 3/16 inch away from "I" terminal on module. If there is no spark at "I" terminal module must be replaced. If there is a spark at "I" terminal, module is fine. Inspect pilot assembly for shorted sparker wire or cracked insulator around electrode.
2. Pilot won't light, there is no noise or spark.	a. A shorted or loose connection in wiring configuration or wiring harness.	Remove and reinstall the wiring harness that plugs into module. Verify there is a tight fit. Verify pilot assembly wiring to module. Remove and verify continuity of each wire in wiring harness.
	b. Improper wall switch wiring.	Verify that 110/VAC power is "ON" to junction box.
	c. Module not grounded.	Verify black ground wire from module wire harness is grounded to metal chassis of appliance.
	d. Faulty module.	Turn ON/OFF rocker switch or wall switch to OFF position. Remove ignitor wire "I" from module. Place ON/OFF Rocker switch or wall switch in ON position. Hold ground wire about 3/16 inch away from "I" terminal on module. If there is no spark at "I" terminal module must be replaced. If there is a spark at "I" terminal, module is fine. Inspect pilot assembly for shorted sparker wire or cracked insulator around electrode.
3. Pilot lights but continues to spark, and main burner will not ignite. (If the pilot continues to spark after the pilot flame has been lit, flame rectification has not occurred.)	a. A shorted or loose connection in sensor rod.	Verify all connections to wiring diagram in manual. Verify connections underneath pilot assembly are tight. Verify connections are not grounding out to metal chassis, pilot burner, pilot enclosure or screen if present, or any other metal object.
	b. Poor flame rectification or contaminated sensor rod.	Verify that flame is engulfing sensor rod. If the pilot assembly does not have a ground strap, consider installing one to increase flame rectification. Verify correct pilot orifice is installed and inlet gas specifications. Flame carries rectification current, not the gas. If flame lifts from pilot hood, the circuit is broken. A wrong orifice or too high an inlet pressure can cause pilot flame to lift. The sensor rod may be contaminated. Clean sensor rod with emery cloth.
	c. Module is not grounded.	Verify that module is securely grounded to metal chassis of appliance. Verify that wire harness is firmly connected to module.

## Troubleshooting *(continued)*

### Intellifire Ignition System

Symptom	Possible Causes	Corrective Actions
3. (Continued)	d. Damaged pilot assembly or dirty sensor rod.	Verify that ceramic insulator around the sensor rod is not cracked, damaged, or loose. Verify connection from sensor rod to white sensor wire. Clean sensor rod with emery cloth to remove any contaminants that may have accumulated on sensor rod. Verify continuity with a multimeter with ohms set at lowest range.
	e. Faulty module.	Turn ON/OFF rocker switch or wall switch to OFF position. Remove ignitor wire "I" from module. Place ON/OFF Rocker switch or wall switch in ON position. Hold ground wire about 3/16 inch away from "I" terminal on module. If there is no spark at "I" terminal module must be replaced. If there is a spark at "I" terminal, module is fine. Inspect pilot assembly for shorted sparker wire or cracked insulator around electrode.
4. Pilot sparks, but Pilot will not light.	a. Correct gas supply.	Verify that incoming gas line ball valve is "open". Verify that inlet pressure reading is within acceptable limits, inlet pressure must not exceed 14 in. W.C.
	b. Ignitor gap is too large.	Verify that spark gap from ignitor to pilot hood is .17 in. or 1/8 in.
	c. Module is not grounded.	Verify module is securely grounded to metal chassis of appliance.
	d. Module voltage output / Valve/Pilot solenoid ohms readings.	Verify battery voltage is at least 2.7 volts. Replace batteries if voltage is below 2.7.

# 15

## Maintaining and Servicing Appliance

Although the frequency of appliance servicing and maintenance will depend on use and the type of installation, a qualified service technician should perform an appliance checkup at the beginning of each heating season.

### WARNING

Risk of injury or property damage.

**Before servicing:**

- Turn off gas.
- Turn off electricity to appliance.
- Disable remote control, if one is present.
- Ensure appliance is completely cooled.

**After servicing:**

- Replace any screen or barrier that was removed.
- Reseal and reinstall any venting removed for servicing.

### WARNING

Annual inspection by qualified technician recommended.

**Check:**

- Condition of doors, surrounds and fronts.
- Condition of glass, glass assembly and glass seal.
- Obstructions of combustion and ventilation air.
- Condition of logs.
- Condition of firebox.
- Burner ignition and operation.
- Burner air shutter adjustment
- Gas connections and fittings.
- Obstructions of termination cap.

**Clean:**

- Glass
- Air passageways, grilles, control compartment
- Burner, burner ports

**Risk of:**

- Fire
- Delayed ignition or explosion
- Exposure to combustion fumes
- Odors



### CAUTION



Handle glass assembly with care.

**NOTE:** Clean glass after initial 3-4 hours operation. **Longer operation without cleaning glass may cause a permanent white film on glass.**

**When cleaning glass door:**

- Avoid striking, scratching or slamming glass.
- Do NOT use abrasive cleaners.
- Use a hard water deposit glass cleaner on white film.
- Do NOT clean glass when hot.
- Turn off appliance after 3-4 hours of operation and ALLOW TO COOL.
- Remove and clean glass assembly.
- Replace glass assembly and operate appliance for additional 12 hours.

Refer to maintenance instructions.

### WARNING



Inspect external vent cap regularly.

- Ensure no debris blocks cap.



- Combustible materials blocking cap may ignite.
- Restricted air flow affects burner operation.

Inspect	Maintenance Tasks
Doors, Surrounds and Fronts	1. Assess condition of screen and replace as necessary. <b>Recommend addition of screen if one is not present.</b>
	2. Inspect for scratches, dents or other damage and repair as necessary.
	3. Verify no obstructions to airflow through the louvers.
	4. Verify maintenance of proper clearance to combustible household objects.
Gasket Seal, Glass Assembly and Glass	1. Inspect gasket seal and its condition.
	2. Inspect glass panels for scratches and nicks that can lead to breakage when exposed to heat.
	3. Confirm there is no damage to glass or glass frame. Replace as necessary.
	4. Verify that latches engage properly, clip studs are not stripped, and glass attachment components are intact and operating properly. Replace as necessary.
	5. Clean glass. Replace glass assembly if severely coated with silicate deposits that cannot be removed.
Valve Compartment and Firebox Top	1. Vacuum and wipe out dust, cobwebs, debris or pet hair. Use caution when cleaning these areas. Screw tips that have penetrated the sheet metal are sharp and should be avoided.
	2. Remove any foreign objects.
	3. Verify unobstructed air circulation.
Logs	1. Inspect for broken, damaged, or missing logs. Replace as necessary.
	2. Verify correct log placement and no flame impingement causing sooting. Correct as necessary.
Firebox	1. Inspect for paint condition, warpage, corrosion or perforation. Sand and repaint as necessary.
	2. Replace appliance if firebox has been perforated.
Burner Ignition and Operation	1. Verify burner is properly secured and aligned with pilot or igniter.
	2. Clean off burner top, inspect for plugged ports, corrosion or deterioration. Replace burner if necessary.
	3. Replace ember materials with new dime-size and shape pieces. Do not block ports or obstruct lighting paths.
	4. Check for smooth lighting and ignition carryover to all ports. Verify there is no ignition delay.
	5. Inspect for lifting or other flame problems.
	6. Verify air shutter is clear of dust and debris.
	7. Inspect orifice for soot, dirt or corrosion.
	8. Verify manifold and inlet pressures. Adjust regulator as required.
	9. Inspect pilot flame strength. Clean or replace orifice as necessary.
	10. Inspect thermocouple/thermopile or IPI sensor rod for soot, corrosion and deterioration. Clean with emery cloth or replace as required.
	11. Verify millivolt output. Replace as necessary.
Venting	1. Inspect venting for blockage or obstruction such as bird nests, leaves, etc.
	2. Confirm that termination cap remains clear and unobstructed by plants, etc.
	3. Verify that termination cap clearance to subsequent construction (building additions, decks, fences or sheds) has been maintained.
	4. Inspect for corrosion or separation.
	5. Verify weather stripping, sealing and flashing remains intact.
	6. Inspect draft shield to verify it is not bent, damaged or missing.

# 16

## Reference Materials

### A. Appliance Dimensions Diagram

Dimensions are actual appliance dimensions. Use for reference only. For framing dimensions and clearances refer to **Section 3**.

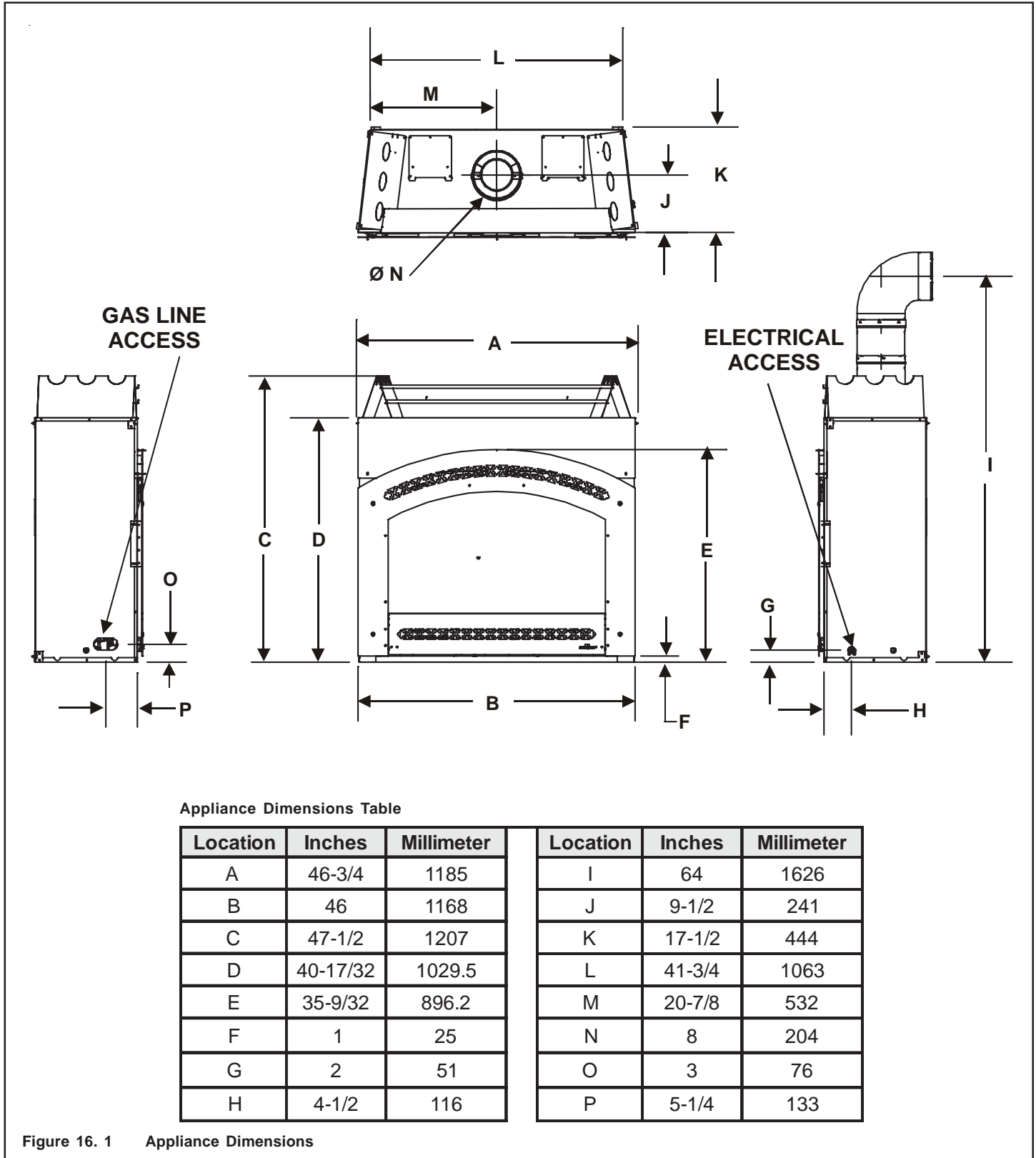
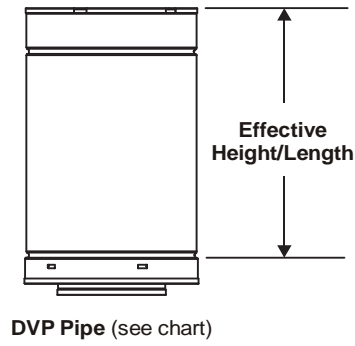

Figure 16. 1 Appliance Dimensions



## B. Vent Components Diagrams



Pipe	Length/Inches
DVP4	4
DVP6	6
DVP12	12
DVP24	24
DVP36	36
DVP48	48
DVP6A	3 to 6
DVP12A	3 to 12
DVP12MI	3 to 12
DVP24MI	3 to 24

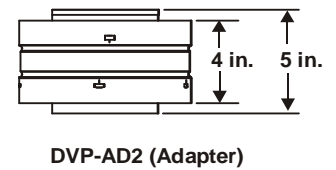
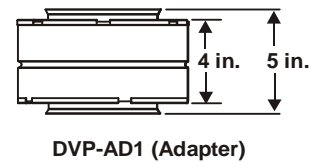
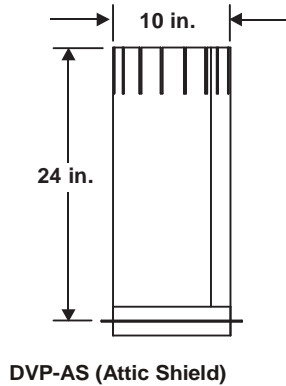
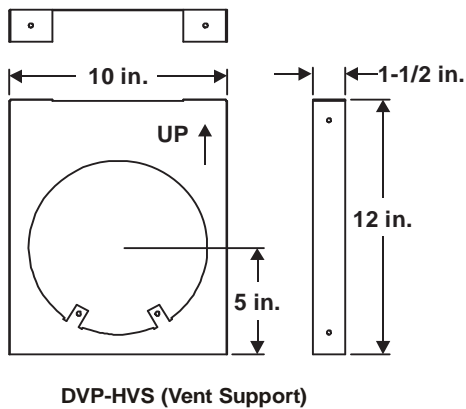
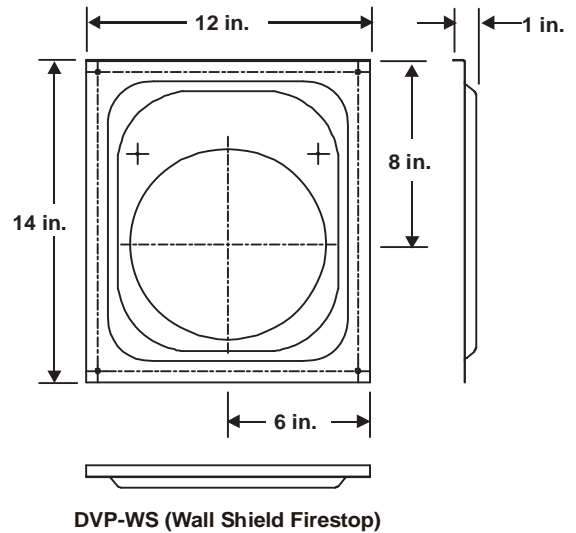
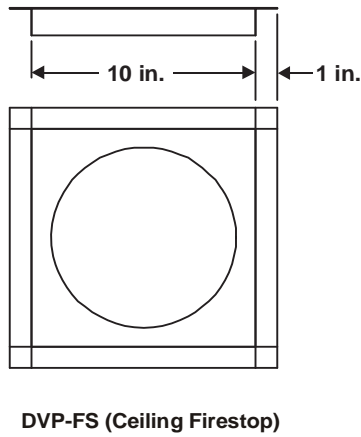
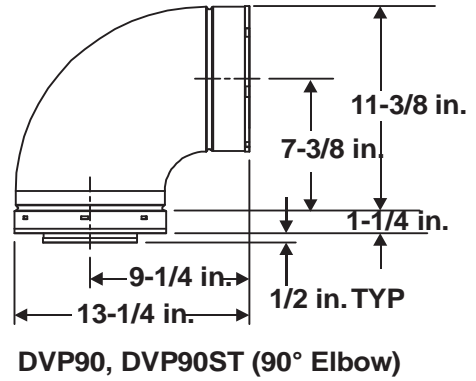
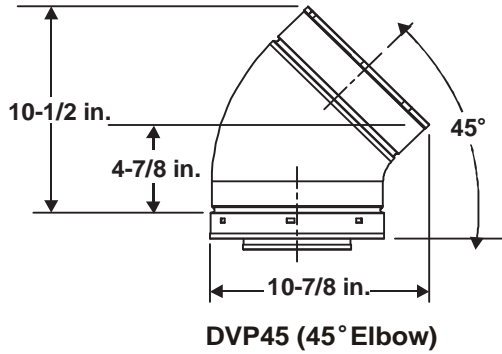
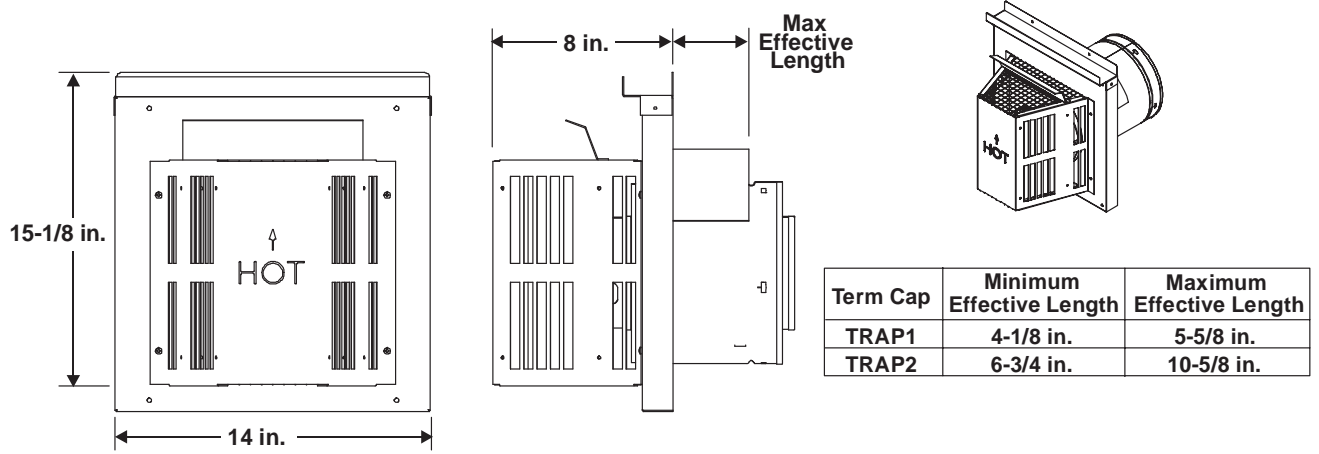

Figure 16.2 DVP vent components

**B. Vent Components Diagrams (continued)**



Term Cap	Minimum Effective Length	Maximum Effective Length
TRAP1	4-1/8 in.	5-5/8 in.
TRAP2	6-3/4 in.	10-5/8 in.

**DVP-TRAP SERIES  
Horizontal Term Cap**

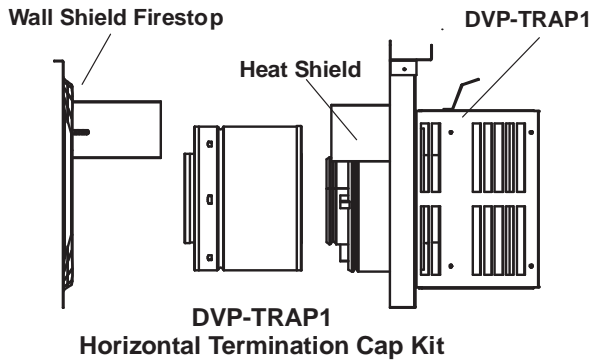

**DVP-TRAP1  
Horizontal Termination Cap Kit**

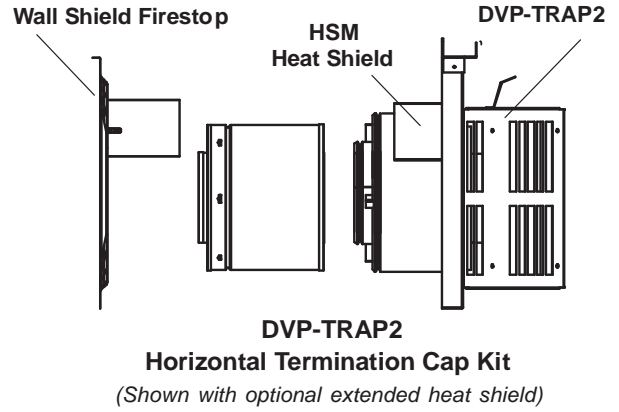

**DVP-TRAP2  
Horizontal Termination Cap Kit**  
*(Shown with optional extended heat shield)*

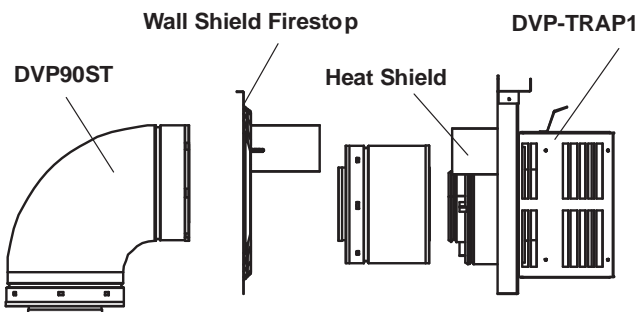

**DVP-TRAPK1  
Horizontal Termination Cap Kit**

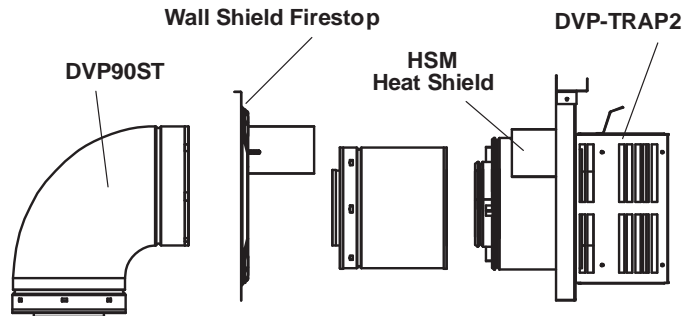

**DVP-TRAPK2  
Horizontal Termination Cap Kit**

**Figure 16.3 DVP vent components**

**B. Vent Components Diagrams (continued)**

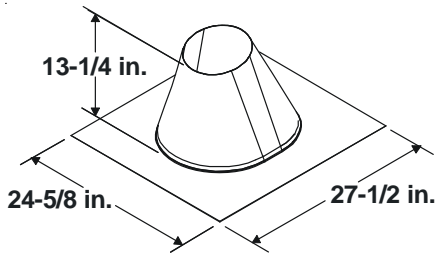

**RF6M**  
Roof Flashing Multi-pak

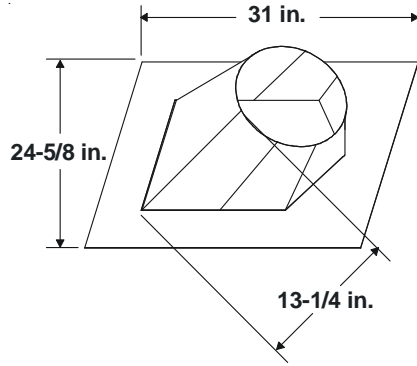

**RF12M**  
Roof Flashing Multi-pak

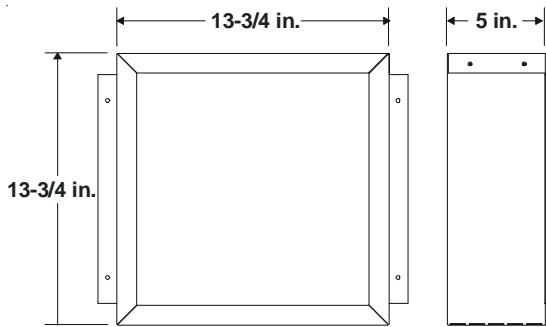

**BEK**  
Trap Cap Brick Extension

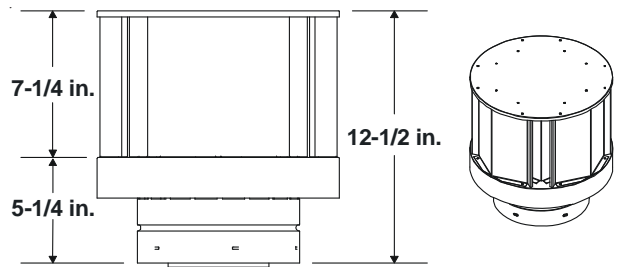

**DVP-TVHW**  
Vertical Termination Cap (High wind)

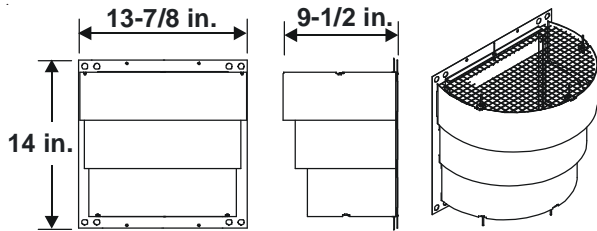

**DRC-RADIUS**  
Cap Shield

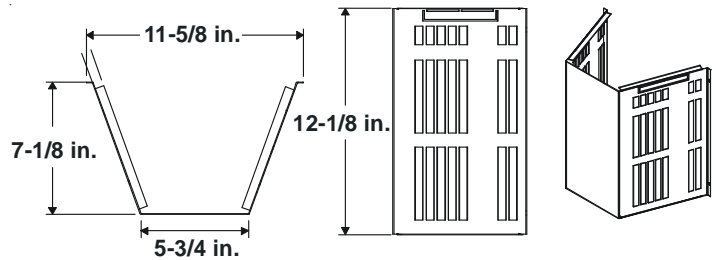

**COOL-ADD**  
Cap Shield

Figure 16. 4 DVP vent components

## D. Limited Lifetime Warranty

### LIMITED LIFETIME WARRANTY HEAT & GLO GAS APPLIANCE PRODUCTS



**BASIC ONE-YEAR WARRANTY.** HEAT & GLO, a brand of HEARTH & HOME TECHNOLOGIES INC., located at 20802 Kensington Boulevard, Lakeville, MN 55044, ("HEAT & GLO") warrants to the original owner that your new HEAT & GLO Gas Appliance (the "Product") will be free from defects in materials and workmanship for a period of one year from the date of installation. During the first year, HEAT & GLO will replace or repair, at its discretion, any defective components at its sole cost and expense, including payment of all reasonable labor costs incurred in replacing or repairing such components. This basic warranty is subject to the conditions, exclusions and limitations described below.

**EXTENDED LIFETIME COVERAGE.** HEAT & GLO warrants that the firebox, heat exchanger, log(s), and burner will not be defective in material or workmanship during the period the Product is owned by the original owner, subject to the following conditions, exclusions and limitations described below.

#### **CONDITIONS, EXCLUSIONS AND LIMITATIONS:**

1. This warranty applies to the original owner only and is nontransferable.
2. This warranty applies only to Products installed in the United States of America or Canada.
3. This warranty is limited to the replacement or repair of defective components or workmanship and HEAT & GLO may fully discharge all obligations under this warranty by repairing or replacing, at its discretion, the defective components. The maximum amount recoverable under this warranty is limited to the purchase price of the Product and, if HEAT & GLO is unable to provide replacement or repair in an expedient and cost-effective manner, HEAT & GLO may discharge all obligations under this warranty by refunding the purchase price of the Product. **IN NO EVENT SHALL HEAT & GLO BE LIABLE FOR ANY INCIDENTAL OR CONSEQUENTIAL DAMAGES CAUSED BY DEFECTS IN THE PRODUCT.**
4. Any labor and related repair charges relating to the costs and expenses of replacing or repairing defective components under the Limited Lifetime Warranty are not covered by this warranty, except as provided for under the Basic One-Year Warranty.
5. Components and parts made by other manufacturers, whether sold with the Product or added thereafter, are NOT covered by this warranty unless expressly authorized and approved by HEAT & GLO in writing.
6. Any damages caused by environmental conditions, inadequate ventilation or drafting caused by tight sealing construction of the structure, air handling devices such as exhaust fans or forced air furnaces, or other such causes are not covered by this warranty.
7. This warranty will be void if:
  - a) The Product is not installed, operated and maintained in compliance with local building codes and with the instructions in the Installer's Guide, Owner's Guide and Listing Agent Identification Label furnished with the Product.
  - b) Any parts or components made by other manufacturers are added or used in the Product, unless expressly authorized and approved by HEAT & GLO in writing.
  - c) Any service work is performed on the Product by anyone other than an authorized HEAT & GLO representative.
  - d) The Product is damaged due to shipping, improper handling, accident, abuse or misuse.
  - e) Fuels other than those specified in the Installer's Guide and Owner's Guide are used.
  - f) Modification was made to the Product which was not expressly authorized and approved by HEAT & GLO in writing.

**EXCEPT TO THE EXTENT PROVIDED BY LAW, HEAT & GLO MAKES NO EXPRESS WARRANTIES OTHER THAN THE WARRANTY SPECIFIED HEREIN. THE DURATION OF ANY IMPLIED WARRANTY IS LIMITED TO THE DURATION OF THE WARRANTY SPECIFIED ABOVE.**

Some states do not allow limitations on how long an implied warranty lasts, or do not allow exclusion or limitation of incidental or consequential damages, so those limitations may not apply to you. This warranty gives you specific legal rights, and you may also have other rights which vary from State to State.

If warranty service is needed you should contact your installing dealer and if the installing dealer is unable to provide necessary parts or components, contact the nearest authorized HEAT & GLO dealer or supplier.

#### **NOTES TO CUSTOMER:**

1. In order to insure proper installation, operation and maintenance HEAT & GLO strongly recommends annual servicing by an authorized HEAT & GLO dealer.
2. Please complete this information and retain this warranty in a safe place for future reference: Installation Date: \_\_\_\_\_  
Model #: \_\_\_\_\_ Serial #: \_\_\_\_\_ Installing Contractor: \_\_\_\_\_
3. HEAT & GLO reserves the right to make changes at any time, without notice, in design, material, specifications and prices of the Product. HEAT & GLO also reserves the right to discontinue styles and products.

## E. Contact Information



Where everything comes together

Heat & Glo, a brand of Hearth & Home Technologies Inc.  
20802 Kensington Boulevard, Lakeville, MN 55044  
www.fireplaces.com

Please contact your Heat & Glo dealer with any questions or concerns.  
For the number of your nearest Heat & Glo dealer,  
please call 1-888-427-3973.

### - NOTES -

---

---

---

---

---

---

---

---

---

---

### CAUTION



- Important operating and maintenance instructions included.

#### DO NOT DISCARD THIS MANUAL

- Read, understand and follow these instructions for safe installation and operation.

- Leave this manual with party responsible for use and operation.



This product may be covered by one or more of the following patents: (United States) 4593510, 4686807, 4766876, 4793322, 4811534, 5000162, 5016609, 5076254, 5113843, 5191877, 5218953, 5263471, 5328356, 5341794, 5347983, 5429495, 5452708, 5542407, 5601073, 5613487, 5647340, 5688568, 5762062, 5775408, 5890485, 5931661, 5941237, 5947112, 5996575, 6006743, 6019099, 6048195, 6053165, 6145502, 6170481, 6237588, 6296474, 6374822, 6413079, 6439226, 6484712, 6543698, 6550687, 6601579, 6672860, 6688302B2, 6715724B2, 6729551, 6736133, 6748940, 6748942, 6769426, 6774802, 6796302, 6840261, 6848441, 6863064, 6866205, 6869278, 6875012, 6880275, 6908039, 6919884, D320652, D445174, D462436; (Canada) 1297749, 2195264, 2225408, 2313972; (Australia) 780250, 780403, 1418504 or other U.S. and foreign patents pending.

Printed in U.S.A. - Copyright 2006