

Models:

6000CF-OAK-IPI

6000CFLP-OAKIPI

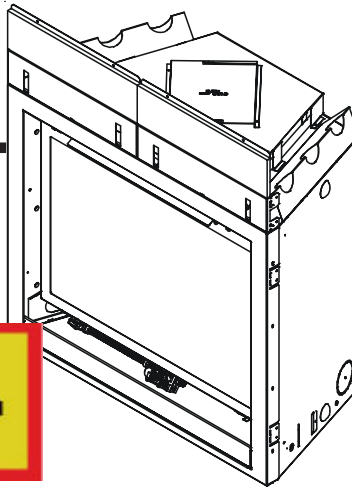

GAS-FIRED



This appliance has been retired.
Service parts pages within have been removed.
For replacement parts, please refer to the individual
service parts list located on the brand websites.

CAUTION



DO NOT DISCARD THIS MANUAL

- Important operating and maintenance instructions included.
- Read, understand and follow these instructions for safe installation and operation.
- Leave this manual with party responsible for use and operation.

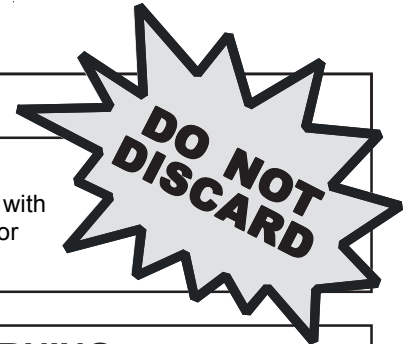

⚠ WARNING: If the information in these instructions is not followed exactly, a fire or explosion may result causing property damage, personal injury, or death.

- Do not store or use gasoline or other flammable vapors and liquids in the vicinity of this or any other appliance.
- **What to do if you smell gas**
 - Do not try to light any appliance
 - Do not touch any electrical switch. Do not use any phone in your building.
 - Immediately call your gas supplier from a neighbor's phone. Follow the gas supplier's instructions.
 - If you cannot reach your gas supplier, call the fire department.
- Installation and service must be performed by a qualified installer, service agency, or the gas supplier.

This appliance may be installed as an OEM installation in manufactured home (USA only) or mobile home and must be installed in accordance with the manufacturer's instructions and the manufactured home construction and safety standard, *Title 24 CFR, Part 3280* or *Standard for Installation in Mobile Homes, CAN/CSA Z240MH*.

This appliance is only for use with the type(s) of gas indicated on the rating plate.

⚠ WARNING



HOT! DO NOT TOUCH.
SEVERE BURNS MAY RESULT.
CLOTHING IGNITION MAY RESULT.

Glass and other surfaces are hot during operation and cool down.

- Keep children away.
- CAREFULLY SUPERVISE children in same room as appliance.
- Alert children and adults to hazards of high temperatures.
- Do NOT operate with protective barriers open or removed.
- Keep clothing, furniture, draperies and other combustibles away.

This appliance has been supplied with an integral barrier to prevent direct contact with the fixed glass panel. Do NOT operate the appliance with the barrier removed.

Contact your dealer or Hearth & Home Technologies if the barrier is not present or help is needed to properly install one.

In the Commonwealth of Massachusetts:

- installation must be performed by a licensed plumber or gas fitter;
- a CO detector shall be installed in the room where the appliance is installed.



Installation and service of this appliance should be performed by qualified personnel. Hearth & Home Technologies suggests NFI certified or factory-trained professionals, or technicians supervised by an NFI certified professional.



Read this manual before installing or operating this appliance.
Please retain this owner's manual for future reference.

Congratulations

Congratulations on selecting a Heat & Glo gas appliance —an elegant and clean alternative to wood burning appliances. The Heat & Glo gas appliance you have selected is designed to provide the utmost in safety, reliability, and efficiency.

As the owner of a new appliance, you'll want to read and carefully follow all of the instructions contained in this *Owner's Manual*. Pay special attention to all Cautions and Warnings.

This *Owner's Manual* should be retained for future reference. We suggest that you keep it with your other important documents and product manuals.

The information contained in this *Owner's Manual*, unless noted otherwise, applies to all models and gas control systems.

Your new Heat & Glo gas appliance will give you years of durable use and trouble-free enjoyment. Welcome to the Heat & Glo family of appliance products!

<h3>Homeowner Reference Information</h3> <p>Model Name: _____ Date purchased/installed: _____</p> <p>Serial Number: _____ Location on appliance: _____</p> <p>Dealership purchased from: _____ Dealer Phone: _____</p> <p>Notes: _____</p> <p>_____</p>	<p><i>We recommend that you record the following pertinent information about your appliance.</i></p>
---	--

Listing Label Information/Location

The model information regarding your specific appliance can be found on the rating plate usually located in the control area of the appliance.

Type of Gas

Gas and Electric Information

This product may be covered by one or more of the following patents: (Nos produits sont couverts par un ou plusieurs des brevets suivants): (United States) 4593510, 4686807, 4766876, 4793322, 4811534, 5000162, 5016609, 5076254, 5113843, 5191877, 5218953, 5263471, 5328356, 5341794, 5347983, 5428496, 5452708, 5542407, 5601073, 5613487, 5647340, 5688568, 5762062, 5775408, 5890485, 5931661, 5941237, 5947112, 5996575, 6008743, 6019099, 6048195, 6053165, 6145502, 6170481, 6237588, 6296474, 6374822, 6413079, 6439226, 6484712, 6543698, 6550687, 6601579, 6672860, 6688302B2, 6715724B2, 6729551, 6736133, 6748940, 6748942, D320652, D445174, D462436; (Canada) 1297749, 2195264, 2225408; or other U.S. and foreign patents pending (ou autres brevets américains et étrangers en attente).



Heat & Glo, a brand of Hearth & Home Technologies, Inc.
20802 Kensington Boulevard, Lakeville, MN 55044

GAS-FIRED



Where everything comes together

Not for use with solid fuel.
(Ne doit pas être utilisé avec un combustible solide).

Type of Gas (Sorte De Gaz): This appliance must be installed in accordance with local codes, if any; if not, follow ANSI Z223.1 in the USA or CAN/CGA B149 installation codes. *(Installer l'appareil selon les codes ou règlements locaux ou, en l'absence de tels règlements, selon les codes d'installation CAN/CGA-B149.)*

NATURAL GAS

ANSI Z21XX-XXXX · CSA 2.XX-MXX · UL307B

Minimum Permissible Gas Supply for Purposes of Input Adjustment.

Approved Minimum (De Gaz) Acceptable	0.0 in w.c.	(Po. Col. d'eau)
Maximum Pressure (Pression)	0.0 in w.c.	(Po. Col. d'eau)
Maximum Manifold Pressure (Pression)	0.0 in w.c.	(Po. Col. d'eau)
Minimum Manifold Pressure (Pression)	0.0 in w.c.	(Po. Col. d'eau)

Total Electrical Requirements: 000Vac, 00Hz., less than 00 Amperes

MADE IN USA

		IN CANADA		
ALTITUDE:	0-0000 FT.	0000-0000FT.	Model:	XXXXXXXX
MAX. INPUT BTUH:	00,000	00,000	(Model):	_____
MIN. INPUT BTUH:	00,000	00,000	Serial	XXXXXXXX
ORIFICE SIZE:	#XXXXX	#XXXXX	(Serie):	_____

- Table of Contents -

<p>Section 1: Listing and Code Approvals</p> <ul style="list-style-type: none"> A. Appliance Certification 4 B. Glass Specifications 4 C. BTU Specifications 4 D. High Altitude Installations 4 E. Non-Combustible Materials Specification ... 4 F. Combustible Materials Specification 4 <p>Section 2: Getting Started</p> <ul style="list-style-type: none"> A. Design and Installation Considerations 5 B. Tools and Supplies Needed 5 C. Inspect Appliance and Components 5 <p>Section 3: Framing and Clearances</p> <ul style="list-style-type: none"> A. Selecting Appliance Location 6 B. Constructing the Appliance Chase 7 C. Clearances 7 D. Mantel Projections 8 <p>Section 4: Termination Locations</p> <ul style="list-style-type: none"> A. Vent Termination Minimum Clearances 9 <p>Section 5: Vent Information and Diagrams</p> <ul style="list-style-type: none"> A. Vent Table Key 11 B. Use of Elbows 11 C. Measuring Standards 11 D. Vent Diagrams 12 <p>Section 6: Vent Clearances and Framing</p> <ul style="list-style-type: none"> A. Pipe Clearances to Combustibles 16 B. Wall Penetration Framing 17 C. Vertical Penetration Framing 18 <p>Section 7: Appliance Preparation</p> <ul style="list-style-type: none"> A. Attaching Sheetrock Ledge 19 B. Temporary Access Panel 19 C. Securing and Leveling the Appliance 20 D. Installing Flue Restrictor 21 E. Installing the Fiberglass Gasket 21 <p>Section 8: Installing Vent Pipe</p> <ul style="list-style-type: none"> A. Assembly of Vent Sections 22 B. Disassembly of Vent Sections 24 C. Installing Heat Shield & Termination Cap . 25 D. Installing Roof Flashing and Vertical Termination Cap 26 	<p>Section 9: Gas Information</p> <ul style="list-style-type: none"> A. Fuel Conversions 28 B. Gas Pressures 28 C. Gas Connection 28 <p>Section 10: Electrical Information</p> <ul style="list-style-type: none"> A. Recommendation for Wire 30 B. Connecting to the Appliance 30 C. Intellifire Ignition System Wiring 30 D. Wall Switch 30 E. Junction Box Installation 32 F. Wall Switch Installation for Fan 32 <p>Section 11: Finishing</p> <ul style="list-style-type: none"> A. Mantel Projections 33 B. Facing Material 33 <p>Section 12: Appliance Setup</p> <ul style="list-style-type: none"> A. Remove Shipping Materials 34 B. Clean the Appliance 34 C. Accessories 34 ← D. Install the Refractory 35 E. Ember Placement 35 F. Positioning the Logs 36 G. Glass Assembly 38 H. Screen Mesh 38 I. Grilles and Trim 38 J. Hood 38 K. Air Shutter Setting 38 <p>Section 13: Operating Instructions</p> <ul style="list-style-type: none"> A. Before Lighting Appliance 39 B. Lighting Appliance 40 C. After Appliance is Lit 41 D. Frequently Asked Questions 41 <p>Section 14: Troubleshooting</p> <ul style="list-style-type: none"> A. Intellifire Ignition System 42 <p>Section 15: Maintaining and Servicing Appliance. 44</p> <p>Section 16: Reference</p> <ul style="list-style-type: none"> A. Appliance Dimension Diagram 46 B. Vent Components Diagrams 47 C. Service Parts 50 D. Warranty 53 E. Contact Information 54
--	---

➔ = Contains updated information.

1

Listing and Code Approvals

A. Appliance Certification

MODELS: 6000CF-OAK-IPI, 6000CFLP-OAKIPI
LABORATORY: Underwriters Laboratories, Inc. (UL)
TYPE: Direct Vent Gas Fireplace Heater
STANDARD: ANSI Z21.88-2000•CSA2.33-M98-UL307B

This product is listed to ANSI standards for “Vented Gas Appliance Heaters” and applicable sections of “Gas Burning Heating Appliances for Manufactured Homes and Recreational Vehicles”, and “Gas Fired Appliances for Use at High Altitudes”.

NOT INTENDED FOR USE AS A PRIMARY HEAT SOURCE.
 This appliance is tested and approved as either supplemental room heat or as a decorative appliance. It should not be factored as primary heat in residential heating calculations.

B. Glass Specifications

Hearth & Home Technologies appliances manufactured with tempered glass may be installed in hazardous locations such as bathtub enclosures as defined by the Consumer Product Safety Commission (CPSC). The tempered glass has been tested and certified to the requirements of **ANSI Z97.1** and **CPSC 16 CFR 1202** (Safety Glazing Certification Council **SGCC# 1595** and **1597**. Architectural Testing, Inc. Reports **02-31919.01** and **02-31917.01**).

This statement is in compliance with **CPSC 16 CFR Section 1201.5** “Certification and labeling requirements” which refers to **15 U.S. Code (USC) 2063** stating “...Such certificate shall accompany the product or shall otherwise be furnished to any distributor or retailer to whom the product is delivered.”

Some local building codes require the use of tempered glass with permanent marking in such locations. Glass meeting this requirement is available from the factory. Please contact your dealer or distributor to order.

NOTE: This installation must conform with local codes. In the absence of local codes you must comply with the **National Fuel Gas Code, ANSI Z223.1-latest edition** in the U.S.A. and the **CAN/CGA B149 Installation Codes** in Canada.

C. BTU Specifications

Model <i>U.S. (0-2000FT.) or Canada (2000-4500FT)</i>		Maximum Input BTUH	Minimum Input BTUH	Orifice Size (DMS)
6000CF-OAK-IPI (NG)	US	30,000	20,000	37
	CAN	27,000	18,000	38
6000CFLP-OAKIPI	US	30,000	18,500	52
	CAN	27,000	16,650	53

D. High Altitude Installations

U.L. Listed gas appliances are tested and approved without requiring changes for elevations from 0 to 2000 feet in the U.S.A. and Canada.

When installing this appliance at an elevation above 2000 feet, it may be necessary to decrease the input rating by changing the existing burner orifice to a smaller size. Input rate should be reduced by 4% for each 1000 feet above a 2000 foot elevation in the U.S.A., or 10% for elevations between 2000 and 4500 feet in Canada. If the heating value of the gas has been reduced, these rules do not apply. To identify the proper orifice size, check with the local gas utility.

If installing this appliance at an elevation above 4500 feet (in Canada), check with local authorities.

WARNING

Do NOT use this appliance if any part has been under water. Immediately call a qualified service technician to inspect the appliance and to replace any part of the control system and any gas control which has been under water.

E. Non-Combustible Materials Specification

Material which will not ignite and burn. Such materials are those consisting entirely of steel, iron, brick, tile, concrete, slate, glass or plasters, or any combination thereof. Materials that are reported as passing **ASTM E 136, Standard Test Method for Behavior of Materials in a Vertical Tube Furnace at 750°C**, shall be considered non-combustible materials.

F. Combustible Materials Specification

Materials made of or surfaced with wood, compressed paper, plant fibers, plastics, or other material that can ignite and burn, whether flame proofed or not, or whether plastered or unplastered shall be considered combustible materials.



Heat & Glo Quality Systems
 registered by SGS ICS

2

Getting Started

A. Design and Installation Considerations

Heat & Glo direct vent gas appliances are designed to operate with all combustion air siphoned from outside of the building and all exhaust gases expelled to the outside. No additional outside air source is required.

CAUTION

- Check building codes prior to installation.
- Installation **MUST** comply with local, regional, state and national codes and regulations.
 - Consult local building, fire officials or authorities having jurisdiction about restrictions, installation inspection, and permits.

When planning an appliance installation, it's necessary to determine the following information before installing:

- Where the appliance is to be installed.
- The vent system configuration to be used.
- Gas supply piping.
- Electrical wiring.
- Framing and finishing details.
- Whether optional accessories—devices such as a fan, wall switch, or remote control—are desired.



! WARNING

Keep appliance dry.

- Mold or rust may cause odors.
- Water may damage controls.



B. Tools and Supplies Needed

Before beginning the installation be sure that the following tools and building supplies are available.

- | | |
|------------------------|--|
| Reciprocating saw | Framing material |
| Pliers | Hi temp caulking material |
| Hammer | Gloves |
| Phillips screwdriver | Framing square |
| Flat blade screwdriver | Electric drill and bits (1/4 in.) |
| Plumb line | Safety glasses |
| Level | 1/2 - 3/4 inch length, #6 or #8 Self-drilling screws |
| Manometer | Voltmeter |
| Tape measure | Non-corrosive leak check solution |
- One 1/4 inch female connection (for optional fan).

C. Inspect Appliance and Components

! WARNING



Inspect appliance and components for damage. Damaged parts may impair safe operation.

- Do NOT install damaged components.
- Do NOT install incomplete components.
- Do NOT install substitute components.

Report damaged parts to dealer.

- Carefully remove the appliance and components from the packaging.
- The vent system components and trim doors are shipped in separate packages.
- The gas logs may be packaged separately and must be field installed.
- Report to your dealer any parts damaged in shipment, particularly the condition of the glass.
- **Read all of the instructions before starting the installation. Follow these instructions carefully during the installation to ensure maximum safety and benefit.**

! WARNING



Hearth & Home Technologies disclaims any responsibility for, and the warranty will be voided by, the following actions:

- Installation and use of any damaged appliance or vent system component.
- Modification of the appliance or vent system.
- Installation other than as instructed by Hearth & Home Technologies.
- Improper positioning of the gas logs or the glass door.
- Installation and/or use of any component part not approved by Hearth & Home Technologies.

Any such action may cause a fire hazard.

3

Framing and Clearances

NOTE:

- Illustrations reflect typical installations and are FOR DESIGN PURPOSES ONLY.
- Illustrations/diagrams are not drawn to scale.
- Actual installation may vary due to individual design preference.

WARNING



- Fire Risk
Provide adequate clearance:
- Around air openings
 - To combustibles
 - For service access
- Locate appliance away from traffic areas.

A. Selecting Appliance Location

When selecting a location for your appliance it is important to consider the required clearances to walls (see Figure 3.1).

NOTE: For actual appliance dimensions refer to Section 16.

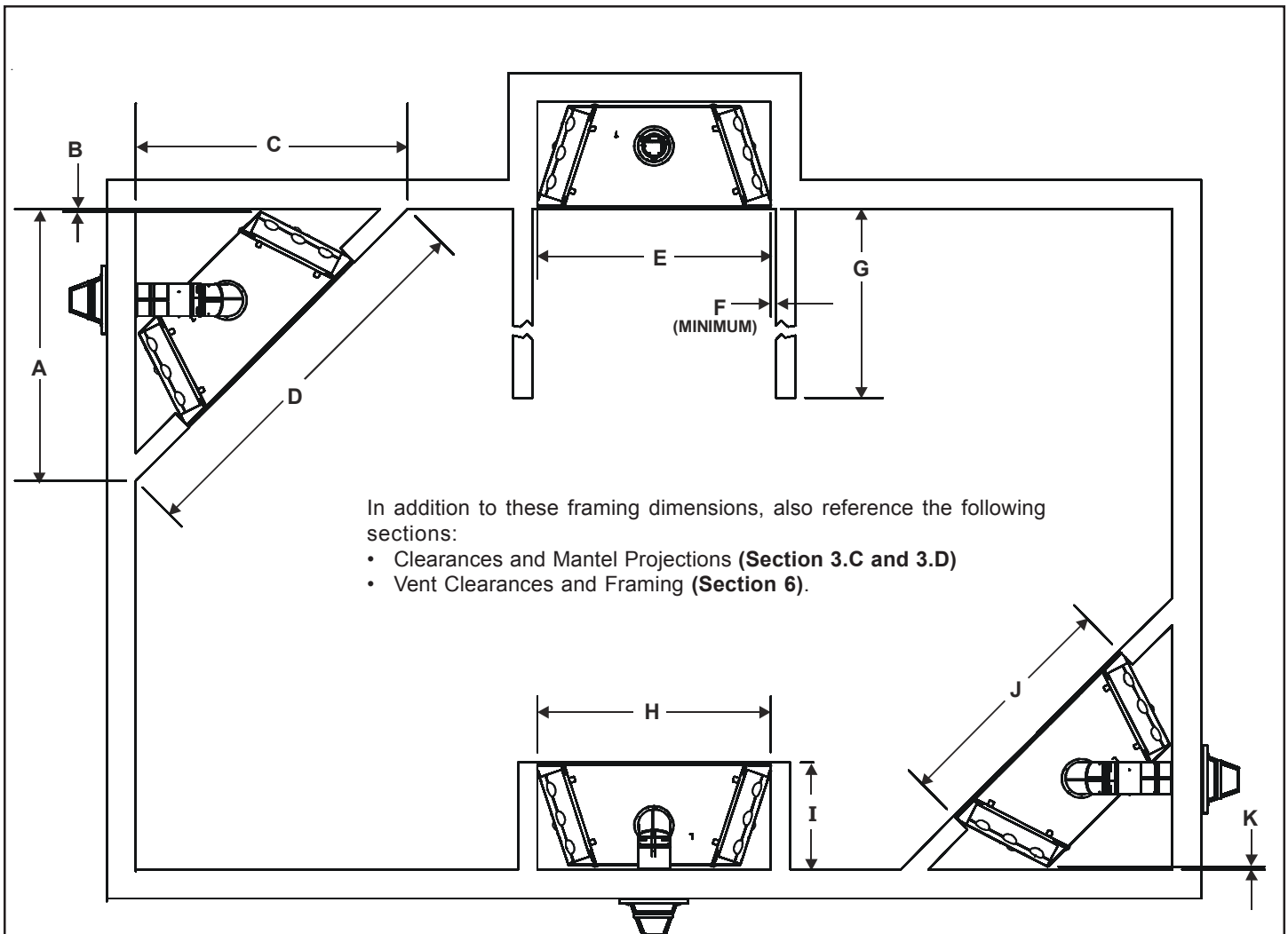

	A	B	C	D	E	F	G	H	I	J	K
Inches	51	1/2	51	72	42	1	38-7/8	42	22	42	1/2
Millimeters	1295	13	1295	1829	1067	25	987	1067	559	1067	13

Figure 3.1 Appliance Locations

B. Constructing the Appliance Chase

A chase is a vertical boxlike structure built to enclose the gas appliance and/or its vent system. Vertical vents that run on the outside of a building may be, but are not required to be, installed inside a chase.

Construction of the chase may vary with the type of building. These instructions are not substitutes for the requirements of local building codes. Local building codes **MUST** be checked.

Chases should be constructed in the manner of all outside walls of the home to prevent cold air drafting problems. The chase should not break the outside building envelope in any manner.

Walls, ceiling, base plate and cantilever floor of the chase should be insulated. Vapor and air infiltration barriers should be installed in the chase as per regional codes for the rest of the home. Additionally, in regions where cold air infiltration may be an issue, the inside surfaces may be sheetrocked and taped for maximum air tightness.

To further prevent drafts, the wall shield and ceiling firestops should be caulked with high temperature caulk to seal gaps. Gas line holes and other openings should be caulked with

high temp caulk or stuffed with unfaced insulation. If the appliance is being installed on a cement slab, a layer of plywood may be placed underneath to prevent conducting cold up into the room.

C. Clearances

⚠ WARNING

Fire Risk.
Odor Risk.

- Install appliance on hard metal or wood surfaces extending full width and depth of appliance.
- Do NOT install appliance directly on carpeting, vinyl, tile or any combustible material other than wood.

⚠ WARNING

Fire Risk.

- Construct chase to all clearance specifications in manual.
- Locate and install appliance to all clearance specifications in manual

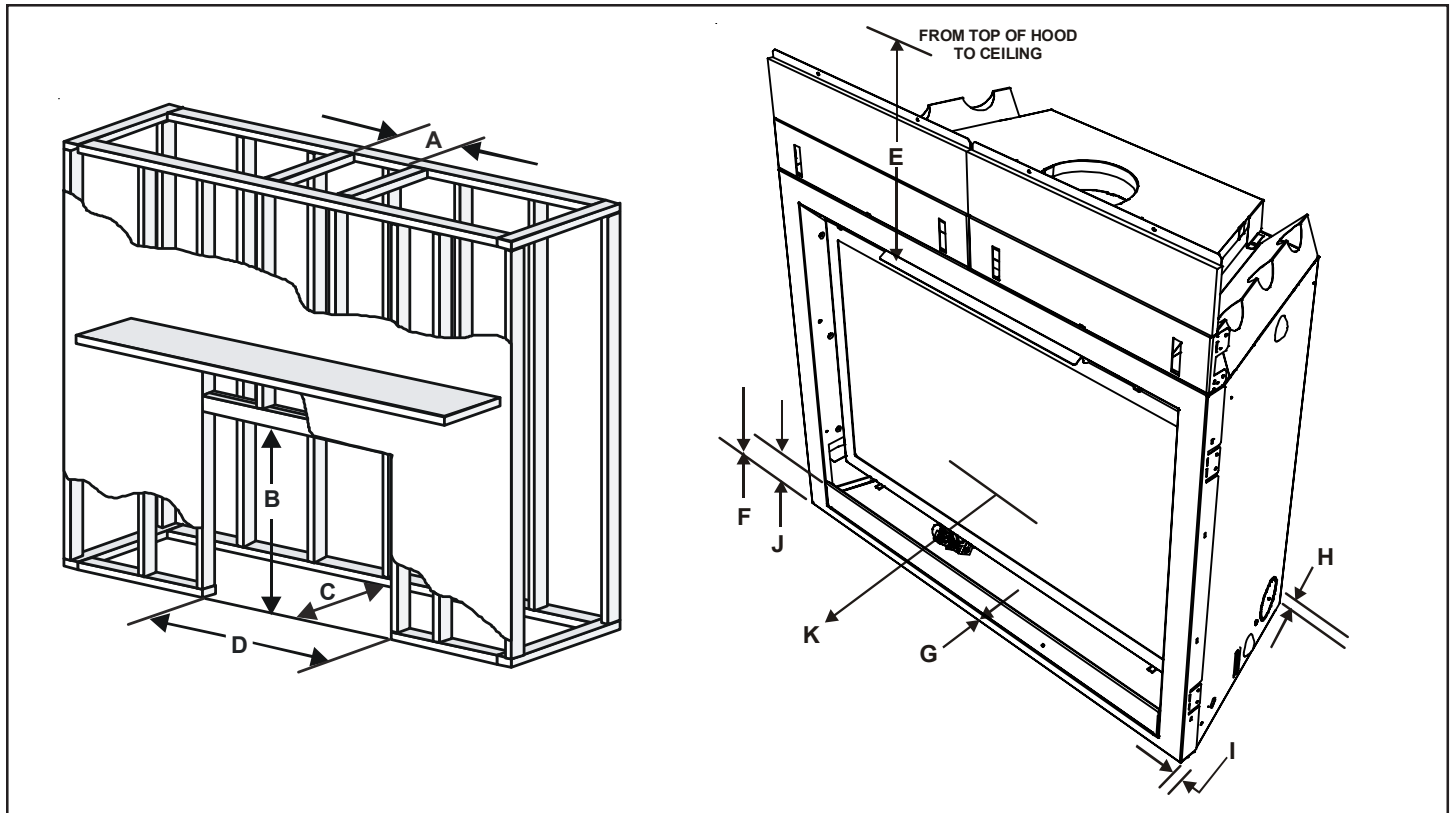

CLEARANCES TO COMBUSTIBLES:											
	A	B	C	D	E	F	G	H	I	J	K
	Rough Opening (Vent Pipe)	Rough Opening (Height)	Rough Opening (Depth)	Rough Opening (Width)	Clearance to Ceiling	Non-Combustible Floor	Combustible Flooring	Behind Appliance	Sides of Appliance	Floor to Top of Access Panel	Front of Appliance
<i>Inches</i>	10	44-3/4	22	42	31	0	0	0.5	0.5	4	36
<i>mm</i>	254	1137	559	1067	788	0	0	13	13	102	914

Figure 3.2 Clearances to Combustibles

D. Mantel Projections

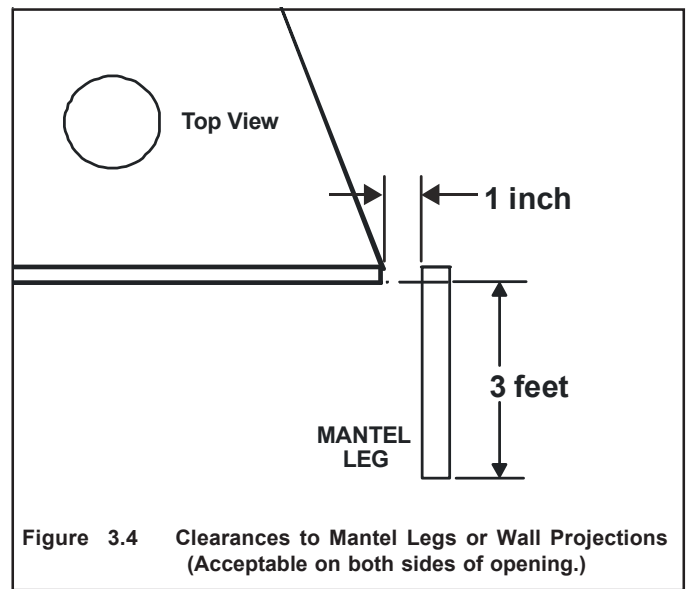
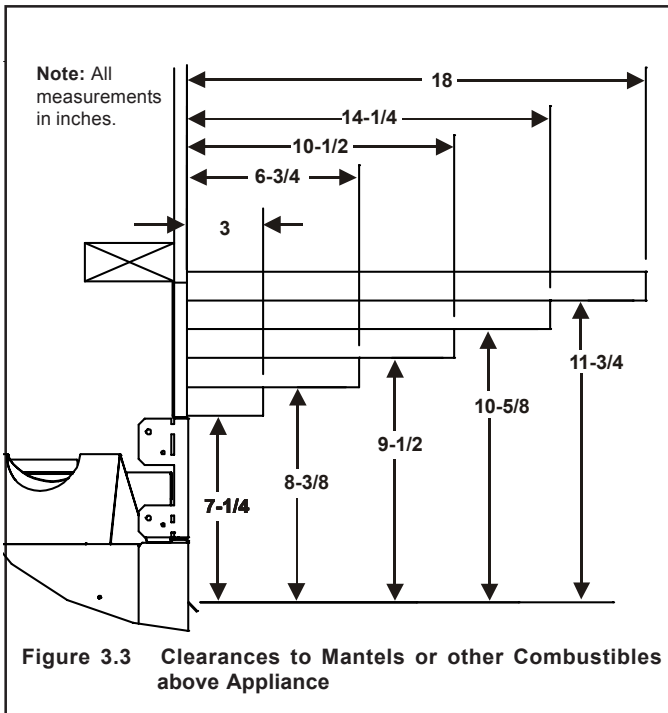

4

Termination Locations

A. Vent Termination Minimum Clearances

WARNING

Fire Risk.
Explosion Risk.
Maintain vent clearance to combustibles as specified.

- Do not pack air space with insulation or other materials.

Failure to keep insulation or other materials away from vent pipe may cause fire.

Measure vertical clearances from this surface.

Measure horizontal clearances from this surface.
(See Figure 4.4 for specific clearances)

Figure 4.1

Roof Pitch	H (Min.) Ft.
Flat to 6/12	1.0*
Over 6/12 to 7/12	1.25*
Over 7/12 to 8/12	1.5*
Over 8/12 to 9/12	2.0*
Over 9/12 to 10/12	2.5
Over 10/12 to 11/12	3.25
Over 11/12 to 12/12	4.0
Over 12/12 to 14/12	5.0
Over 14/12 to 16/12	6.0
Over 16/12 to 18/12	7.0
Over 18/12 to 20/12	7.5
Over 20/12 to 21/12	8.0

* 3 foot minimum in snow regions

Figure 4.2 Minimum Height from Roof to Lowest Discharge Opening

Figure 4.2 specifies minimum vent heights for various pitched roofs.

	Gas Termination	Wood & Fuel Oil Termination
A	6 in.	20 in.

Figure 4.3 Multiple Vertical Termination

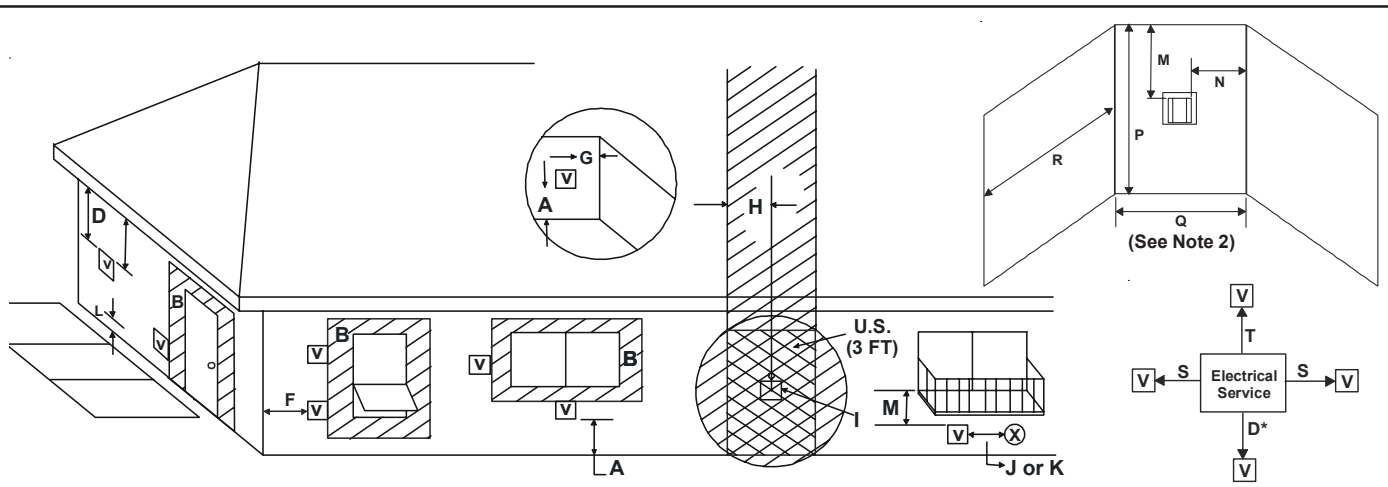

V = VENT TERMINAL **X** = AIR SUPPLY INLET **[Hatched]** = AREA WHERE TERMINAL IS NOT PERMITTED

- A = 12 inches clearances above grade, veranda, porch, deck or balcony
(See Note 1)
- B = 12 inches clearances to window or door that may be opened, or to permanently closed window. (Glass)
- D* = 18 inches vertical clearance to unventilated soffit or to ventilated soffit located above the terminal
*30 inches for vinyl clad soffits and below electrical service
- F = 9 inches clearance to outside corner
- G = 6 inches clearance to inside corner
- H = 3 ft. (Canada) not to be installed above a gas meter/regulator assembly within 3 feet (90cm) horizontally from the center-line of the regulator
- I = 3 ft. (U.S.A.)
6 ft. (Canada) clearance to gas service regulator vent outlet
- J = 9 inches (U.S.A.)
12 inches (Canada) clearance to non-mechanical air supply inlet to building or the combustion air inlet to any other appliance

- K = 3 ft. (U.S.A.)
6 ft. (Canada) clearance to a mechanical (powered) air supply inlet
- L** = 7 ft. clearance above paved sidewalk or a paved driveway located on **public** property
(See Note 1)
- M*** = 18 inches clearance under veranda, porch, deck, balcony or overhang
42 inches vinyl

Alcove Applications

- N = 6 inches non-vinyl sidewalls
12 inches vinyl sidewalls
- P = 8 ft.

	Q_{MIN}	R_{MAX}
1 cap	3 feet	2 x Q _{ACTUAL}
2 caps	6 feet	1 x Q _{ACTUAL}
3 caps	9 feet	2/3 x Q _{ACTUAL}
4 caps	12 feet	1/2 x Q _{ACTUAL}
Q_{MIN} = # termination caps x 3		R_{MAX} = (2 / # termination caps) x Q_{ACTUAL}

- S = 6 inches clearance from sides of electrical service
(See Note 5)
- T = 12 inches clearance above electrical service
(See Note 5)

** a vent shall not terminate directly above a sidewalk or paved driveway which is located between two single family dwellings and serves both dwellings.

*** only permitted if veranda, porch, deck or balcony is fully open on a minimum of 2 sides beneath the floor, or meets Note 2.

NOTE 1: On private property where termination is less than 7 feet above a sidewalk, driveway, deck, porch, veranda or balcony, use of a listed cap shield is suggested. (See vents components page)

NOTE 2: Termination in an alcove space (spaces open only on one side and with an overhang) are permitted with the dimensions specified for vinyl or non-vinyl siding and soffits. **1.** There must be 3 feet minimum between termination caps. **2.** All mechanical air intakes within 10 feet of a termination cap must be a minimum of 3 feet below the termination cap. **3.** All gravity air intakes within 3 feet of a termination cap must be a minimum of 1 foot below the termination cap.

Figure 4.4 Minimum Clearances for Termination

NOTE 3: Local codes or regulations may require different clearances.

NOTE 4: Termination caps may be hot. Consider their proximity to doors or other traffic areas.

NOTE 5: Location of the vent termination must not interfere with access to the electrical service.

WARNING: In the U.S: Vent system termination is **NOT** permitted in screened porches. You must follow side wall, overhang and ground clearances as stated in the instructions.

In Canada: Vent system termination is **NOT** permitted in screened porches. Vent system termination is permitted in porch areas with two or more sides open. You must follow all side walls, overhang and ground clearances as stated in the instructions.

Heat & Glo assumes no responsibility for the improper performance of the appliance when the venting system does not meet these requirements.

CAUTION: IF EXTERIOR WALLS ARE FINISHED WITH VINYL SIDING, IT IS SUGGESTED THAT A VINYL PROTECTOR KIT BE INSTALLED.

5

Vent Information and Diagrams

A. Vent Table Key

The abbreviations listed in this vent table key are used in the vent diagrams.

Symbol	Description
V ₁	First section (closest to appliance) of vertical length
V ₂	Second section of vertical length
H ₁	First section (closest to appliance) of horizontal length
H ₂	Second section of horizontal length

WARNING



Fire Hazard.
Explosion Risk.
Asphyxiation Risk.
Do NOT connect this gas appliance to a chimney flue serving a separate solid-fuel or gas burning appliance.



- Vent this appliance directly outside.
 - Use separate vent system for this appliance.
- May impair safe operation of this appliance or other appliances connected to the flue.

B. Use of Elbows

CAUTION

- ALL vent configuration specifications MUST be followed.
- This product is tested and listed to these specifications.
 - Appliance performance will suffer if specifications are not followed.

Diagonal runs have both vertical and horizontal vent aspects when calculating the effects. Use the rise for the vertical aspect and the run for the horizontal aspect (see Figure 5.1).

Two 45° elbows may be used in place of one 90° elbow. On 45° runs, one foot of diagonal is equal to 8.5 inches horizontal run and 8.5 inches vertical run. A length of straight pipe is allowed between two 45° elbows (see Figure 5.1).

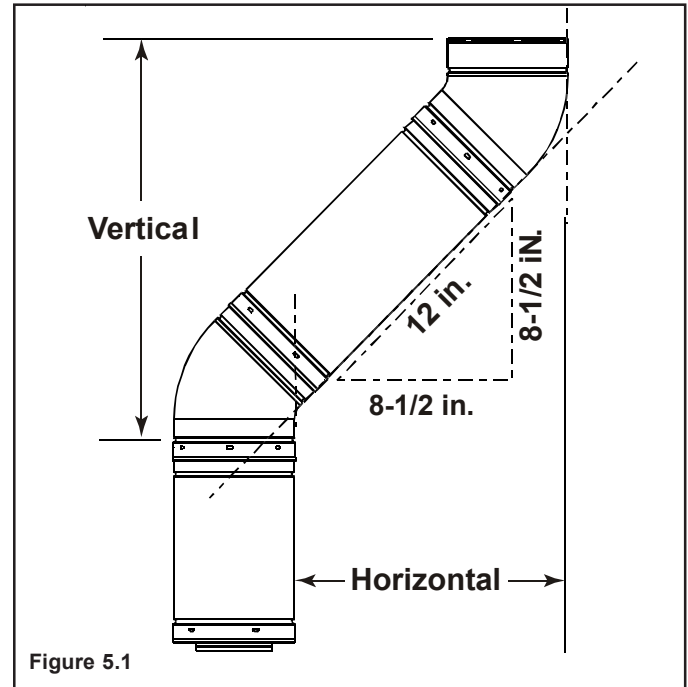

Figure 5.1

C. Measuring Standards

Vertical and horizontal measurements listed in the vent diagrams were made using the following standards.

1. Pipe measurements are shown using the effective length of pipe (see Figure 5.2).
2. Measurements are made from the appliance outer wrap, not from the standoffs.
3. Horizontal terminations are measured to the outside mounting surface (flange of termination cap) (see Figure 4.1).
4. Vertical terminations are measured to bottom of termination cap.
5. Horizontal pipe installed level with no rise.

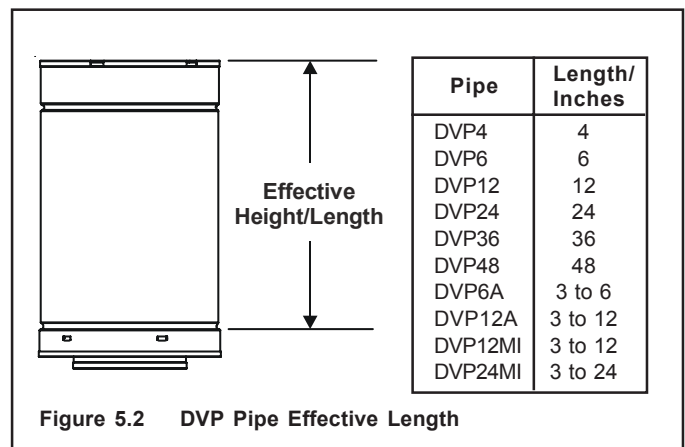

Figure 5.2 DVP Pipe Effective Length

D. Vent Diagrams

⚠ WARNING



Fire Risk. Explosion Risk.
 Do NOT pack insulation or other combustibles between ceiling firestops.
 • ALWAYS maintain specified clearances around venting and firestop systems.
 • Install wall shield and ceiling firestops as specified.
 Failure to keep insulation or other material away from vent pipe may cause fire.



1. Top Vent - Horizontal Termination

One Elbow

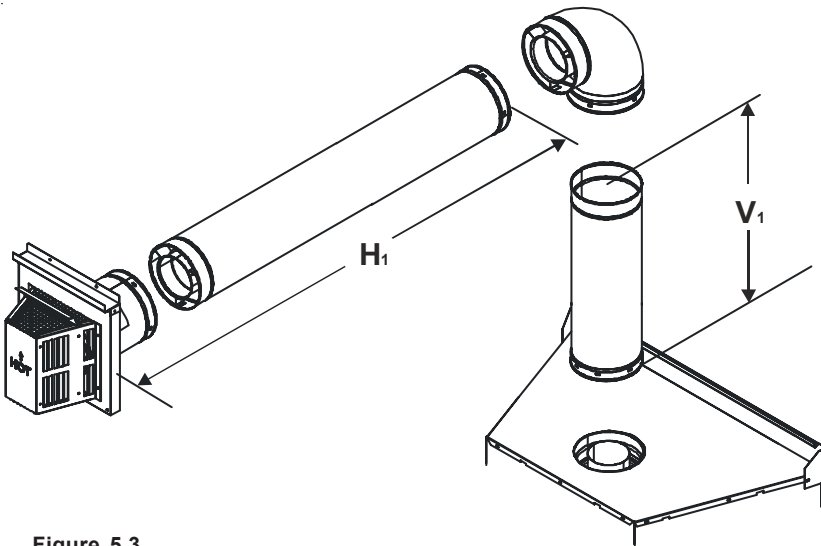

Figure 5.3

V ₁ Minimum		H ₁ Maximum	
6 inches	152mm	3 ft	914 mm
1 ft	305 mm	3 ft	914 mm
2 ft	610 mm	6 ft	1.8 m
3 ft	914 mm	9 ft	2.7 m
4 ft	1.2 m	12 ft	3.7 m
V ₁ + H ₁ = 40 ft (12.2m) Maximum H ₁ = 20 ft (6.1m) Maximum V ₁ = 6 inches (152 mm) Minimum			

Two Elbows

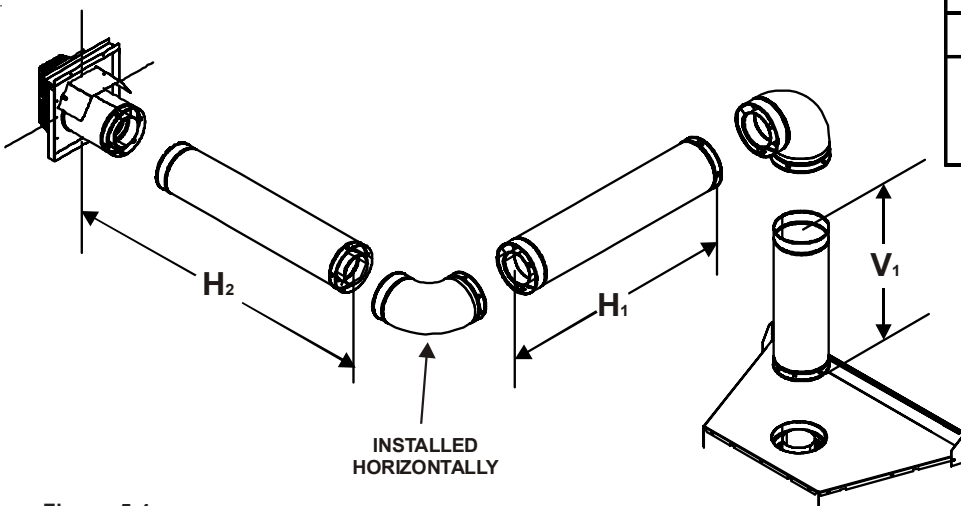

Figure 5.4

V ₁ Minimum		H ₁ + H ₂ Maximum	
1 ft	305 mm	Cannot do	
1-1/2 ft	457 mm	1-1/2 ft	457 mm
2 ft	610 mm	3 ft	914 mm
3 ft	914 mm	6 ft	1.8 m
4 ft	1.2 m	9 ft	2.7 m
V ₁ + H ₁ + H ₂ = 50 ft (15.2m) Maximum H ₁ + H ₂ = 17 ft (5.2m) Maximum V ₁ = 1-1/2 ft (457 mm) Minimum			

1. Top Vent - Horizontal Termination - (continued)

Three Elbows

V ₁ Min.		H ₁ Max.		V ₂ Min.		H ₂ Max.		V ₁ + V ₂ Min.		H ₁ + H ₂ Max.	
6 in.	152 mm	3 ft	914 mm	1 ft	305 mm	3 ft	914 mm	1-1/2 ft	457 mm	6 ft	1.8 m
1 ft	305 mm	3 ft	914 mm	1 ft	305 mm	3 ft	914 mm	2 ft	607 mm	6 ft	1.8 m
2 ft	610 mm	6 ft	1.8 m	2 ft	610 mm	6 ft	1.8 m	4 ft	1.4 m	12 ft	3.7 m
3 ft	914 mm	9 ft	2.7 m	3 ft	914 mm	9 ft	2.7 m	6 ft	1.8 m	18 ft	5.5 m
H ₁ + H ₂ = 20 ft (6.1m) Max.				V ₁ + V ₂ + H ₁ + H ₂ = 50 ft (15.2m) Max.				V ₁ = 6 inches (152 mm) Min.			

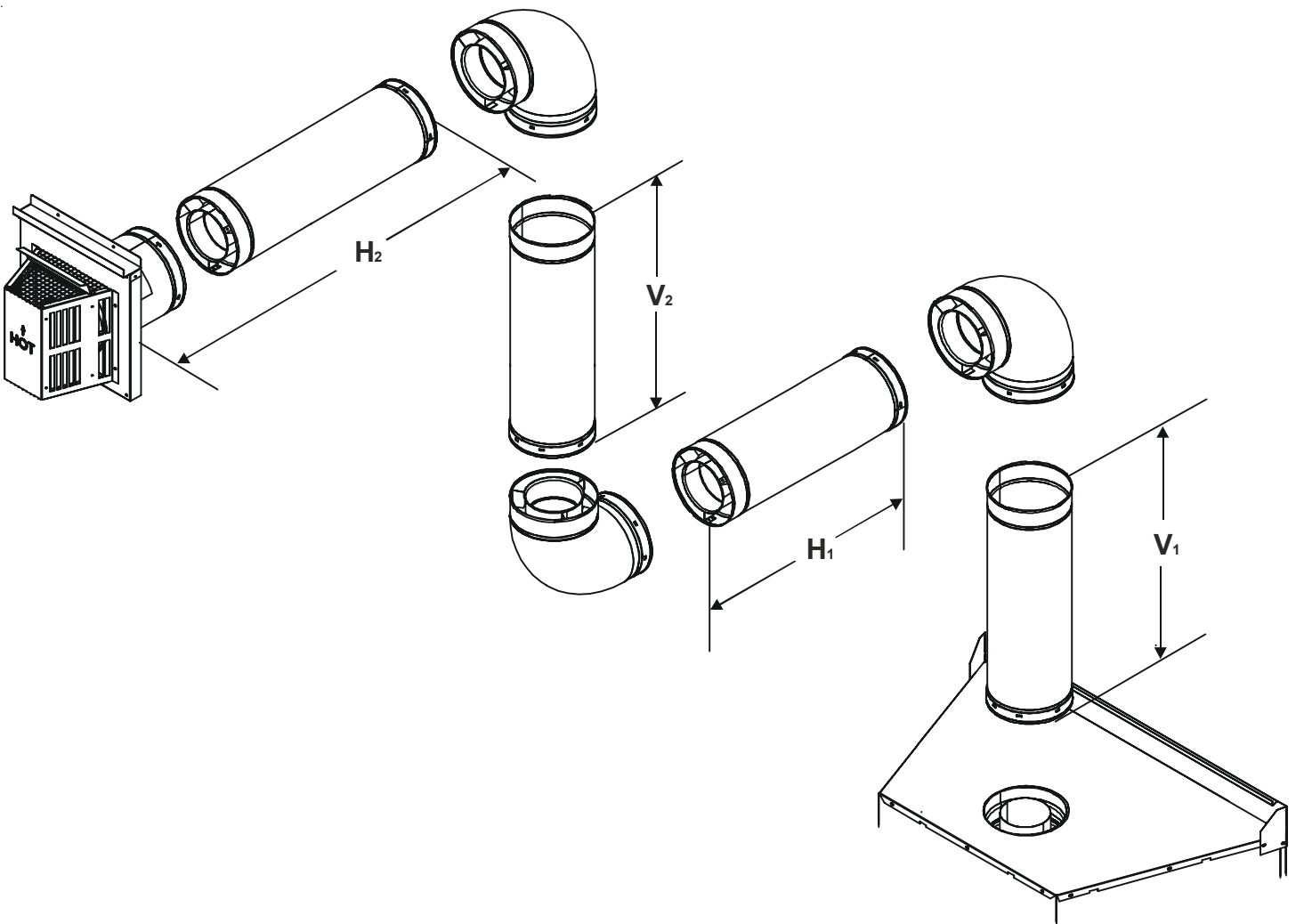
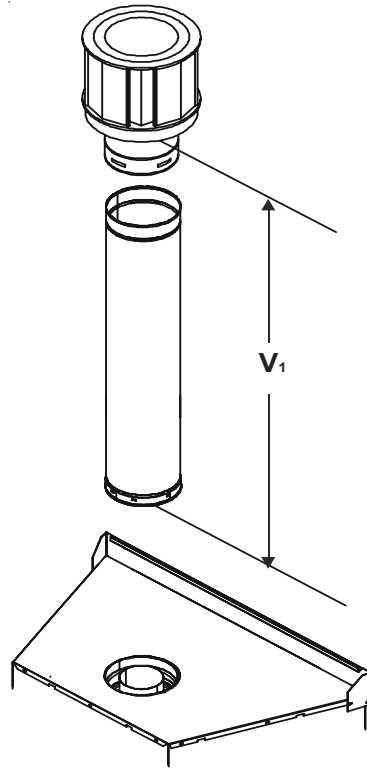

Figure 5.5

2. Top Vent - Vertical Termination

No Elbow



**$V_1 = 40 \text{ ft. Max. (12.2m)}$
 $3 \text{ ft Min. (914mm)}$**

NOTE: If installing a vertical vent/termination off the top of the appliance, the optional flue restrictor should be used. See Section 7.D.

Figure 5.6

Two Elbows

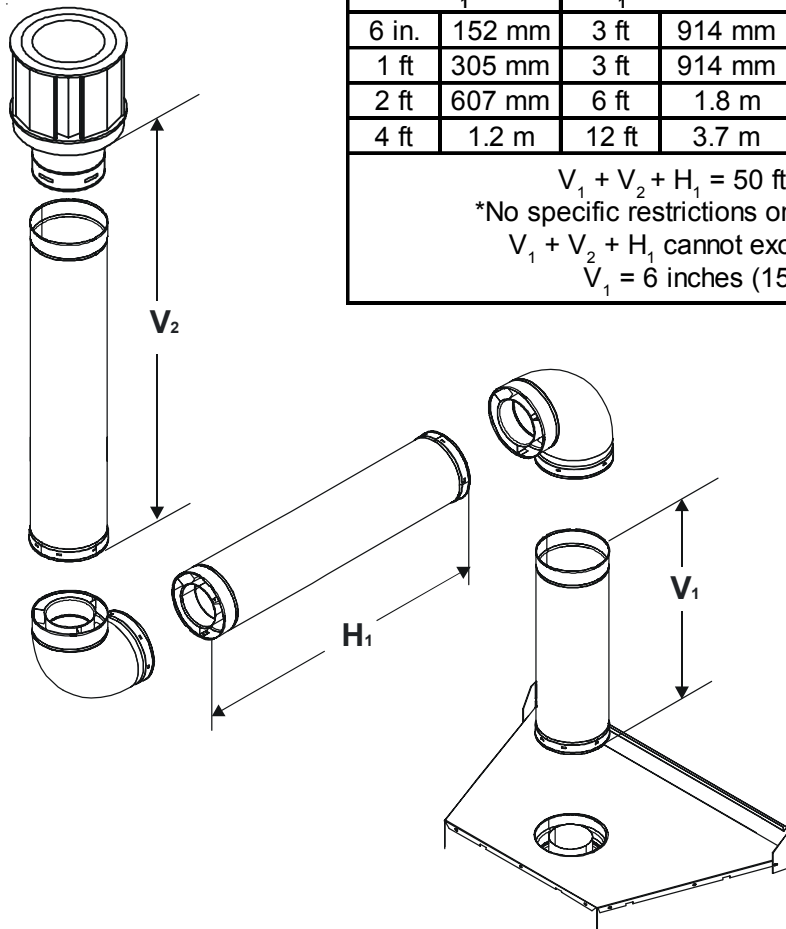

	V_1	H_1 Maximum		V_2	$V_1 + V_2$ Minimum	
6 in.	152 mm	3 ft	914 mm	*	*	*
1 ft	305 mm	3 ft	914 mm	*	*	*
2 ft	607 mm	6 ft	1.8 m	*	*	*
4 ft	1.2 m	12 ft	3.7 m	*	*	*

$V_1 + V_2 + H_1 = 50 \text{ ft (15.2m) Max.}$
 *No specific restrictions on this value EXCEPT
 $V_1 + V_2 + H_1$ cannot exceed 50 ft (15.2m)
 $V_1 = 6 \text{ inches (152 mm) Min.}$

Figure 5.7

2. Top Vent - Vertical Termination - (continued)

Three Elbows

V ₁		H ₁ + H ₂		V ₂	V ₁ + V ₂ Minimum		H ₁ + H ₂ Maximum	
6 in.	152 mm	3 ft	914 mm	*	*	*	3 ft	914 mm
1 ft	305 mm	3 ft	914 mm	*	*	*	3 ft	914 mm
2 ft	610 mm	6 ft	1.8 m	*	*	*	6 ft	1.8 m
4 ft	1.2 m	12 ft	3.7 m	*	*	*	12 ft	3.7 m
H ₁ + H ₂ = 17 ft (5.2m) Maximum V ₁ + V ₂ + H ₁ + H ₂ = 50 ft (15.2m) Maximum V ₁ = 6 inches (152 mm) Minimum								

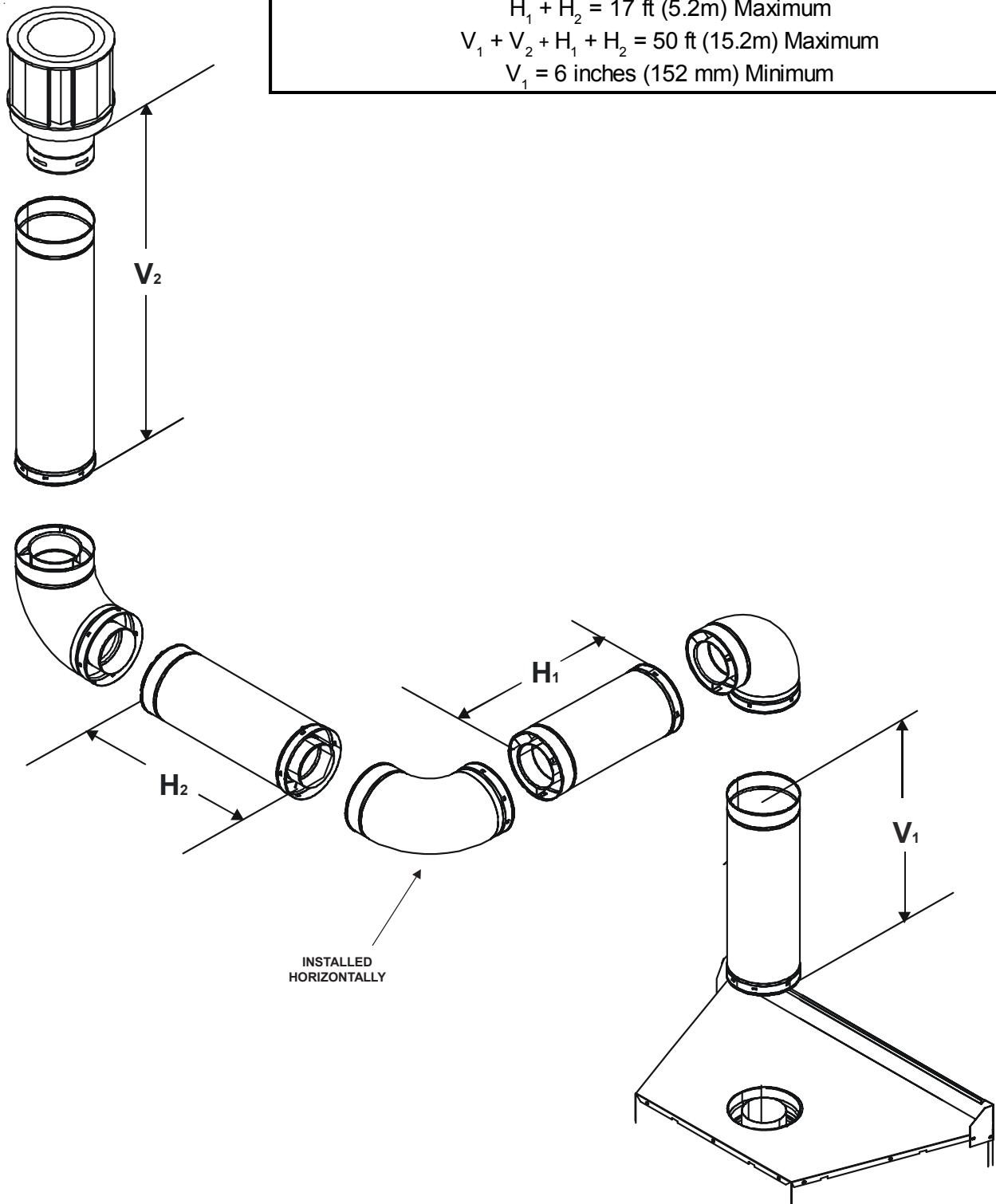

Figure 5.8

6

Vent Clearances and Framing

A. Pipe Clearances to Combustibles

WARNING

Fire Risk.
Explosion Risk.
Maintain vent clearance to combustibles as specified.

- Do not pack air space with insulation or other materials.

Failure to keep insulation or other materials away from vent pipe may cause fire.

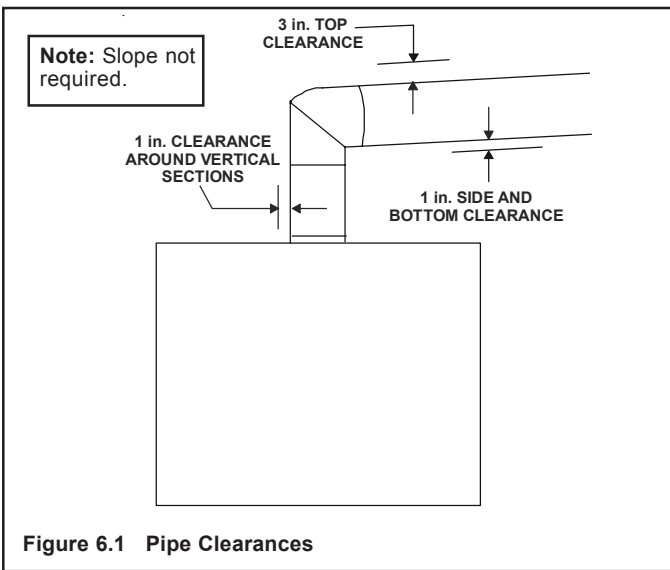

Heat Shield Above First 90° Elbow

WARNING

Fire Risk.
Installation of this appliance may require the use of heat shield 570-290 above the first 90° elbow in the venting system.

- Heat shield required if vertical distance between top of horizontal elbow and any combustible surface above elbow is less than 4 inches.
- Heat shield not required if distance is more than 4 inches.

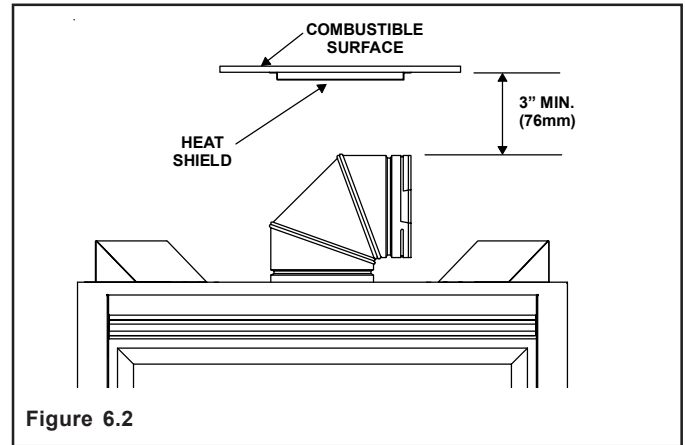

Fasten the shield in place using the four pilot holes provided in the part.

- Position the shield so the longest dimension (13 1/2 inch) is placed in same direction the elbow is pointing.
- Center the shield directly above the elbow with a 1/2 inch air space between shield and combustible surface (see Figure 6.3).

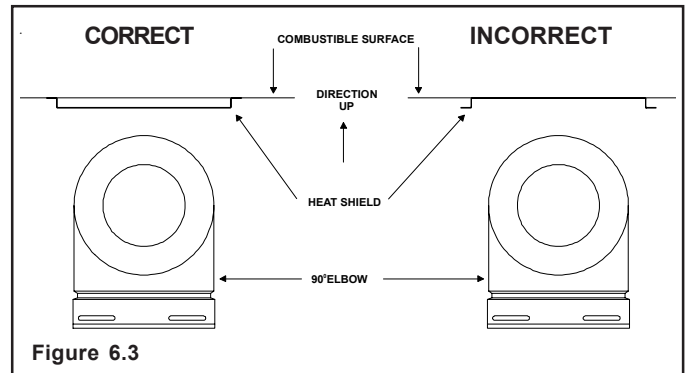

- Attach elbow heat shield to the exhaust pipe if combustible materials are not present at install (see Figure 6.4).
- Cut the tabs as shown and bend down. Using the screws found in the manual bag secure the heat shield to the pipe maintaining 3 to 4 inches between the pipe and shield.

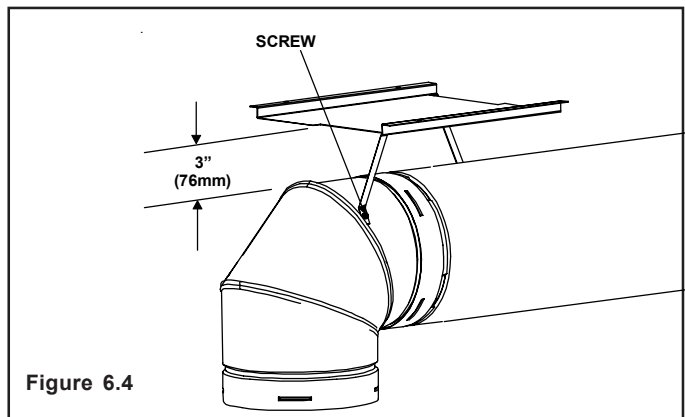

B. Wall Penetration Framing

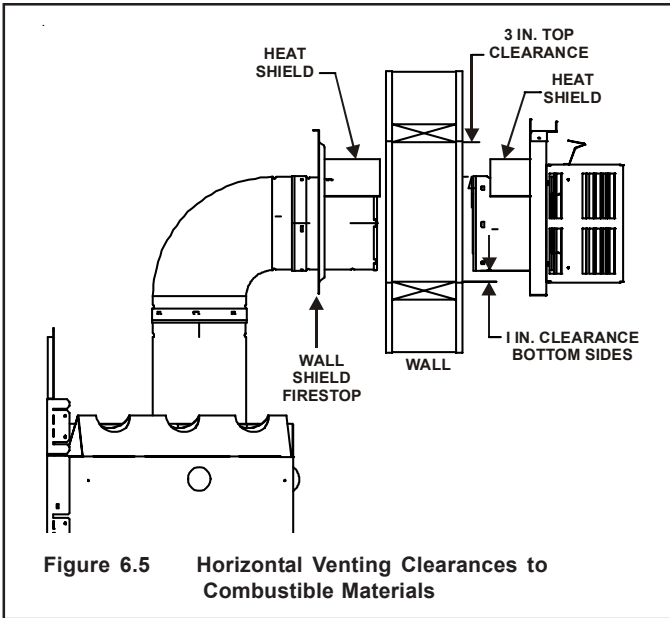

Combustible Wall Penetration

Frame a hole in a combustible wall for an interior wall shield firestop, (Figure 6.6) whenever a wall is penetrated. Use same size framing materials as those used in the wall construction. The wall shield firestop maintains minimum clearances and prevents cold air infiltration.

Non-Combustible Wall Penetration

If the hole being penetrated is surrounded by noncombustible materials such as concrete, a hole with diameter one inch greater than the pipe is acceptable.

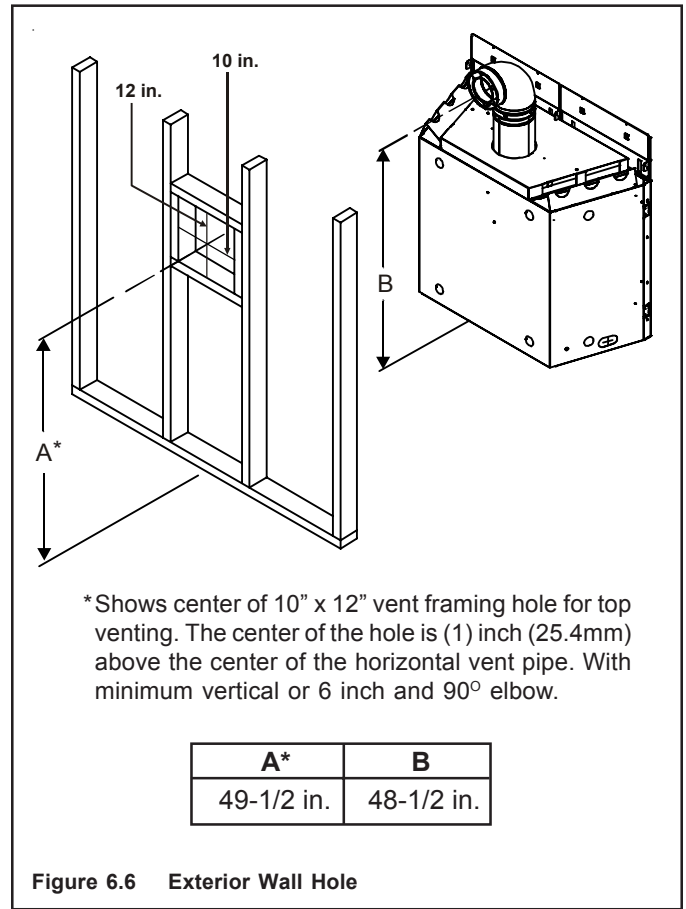

C. Vertical Penetration Framing



WARNING

Fire Hazard

Keep loose materials or blown insulation from touching the vent pipe.

- National building codes recommend using attic shield to keep loose materials/blown insulation from contacting vent.
- Hearth & Home Technologies requires the use of an attic shield.

Installing the Ceiling Firestop

- Frame an opening 10 inches by 10 inches whenever the vent system penetrates a ceiling/floor (see Figure 6.7).
- Frame the area with the same sized lumber as used in ceiling/floor joist.
- When installing a top vent vertical termination appliance the hole should be directly above the appliance, unless the flue is offset.
- Do not pack insulation around the vent. Insulation must be kept away from the pipe.

Installing Attic Shield

Note: An additional ceiling firestop is not required if attic shield is used.

- Frame opening for attic shield.
- Attic shield may be installed above or below ceiling (see Figure 6.8).
- Secure with three fasteners on each side.
- Fold tabs at top of attic shield in toward vent pipe. Tabs must keep vent pipe centered within shield.
- Field construct additional shield height if insulation is deeper than height of attic shield.

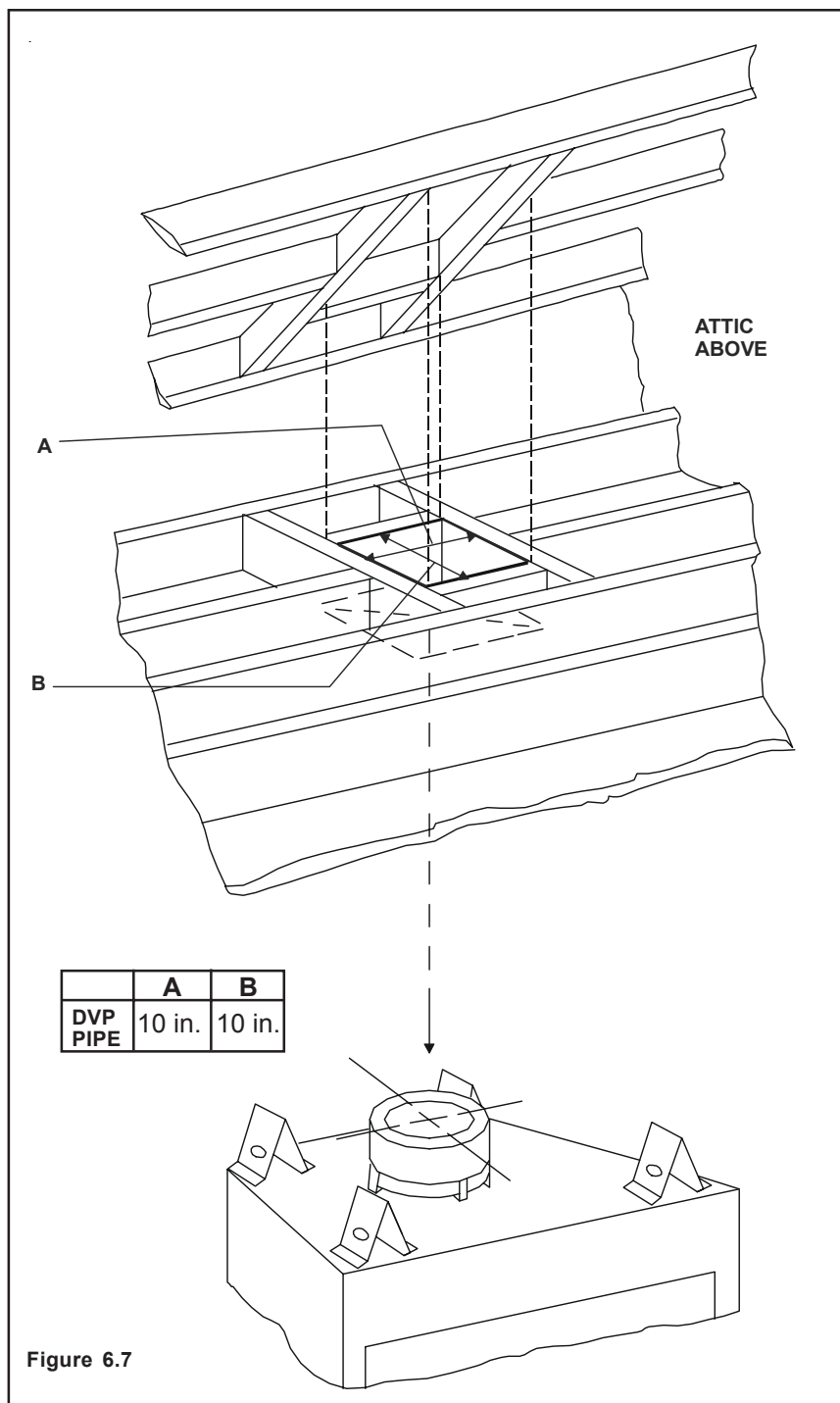

Figure 6.7

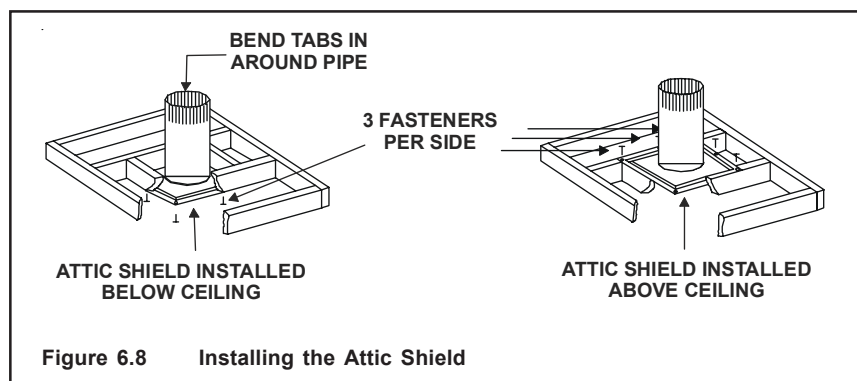

Figure 6.8 Installing the Attic Shield

7

Appliance Preparation

A. Attaching Sheetrock Ledges

Attach sheetrock ledges together using the attachment holes (see Figure 7.1).

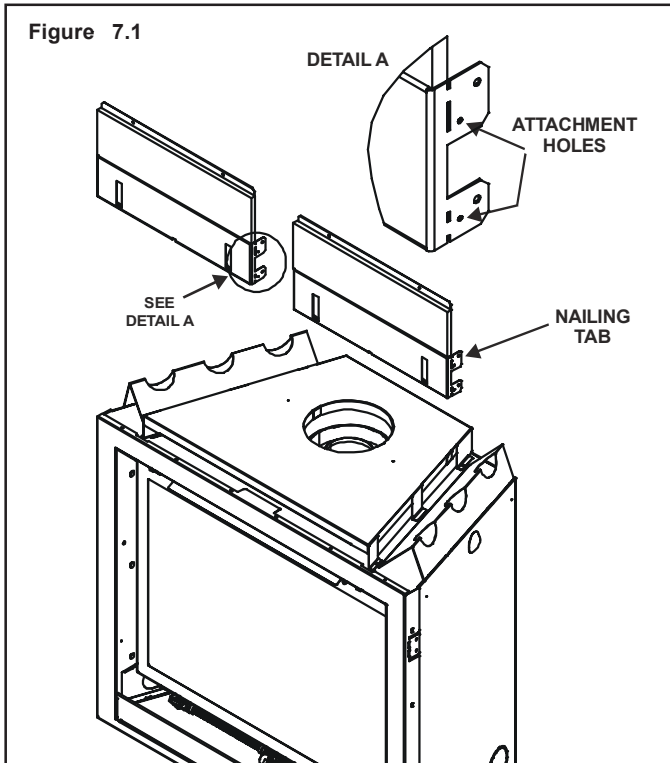

The sheetrock ledges will attach to the top of the unit (see Figure 7.2).

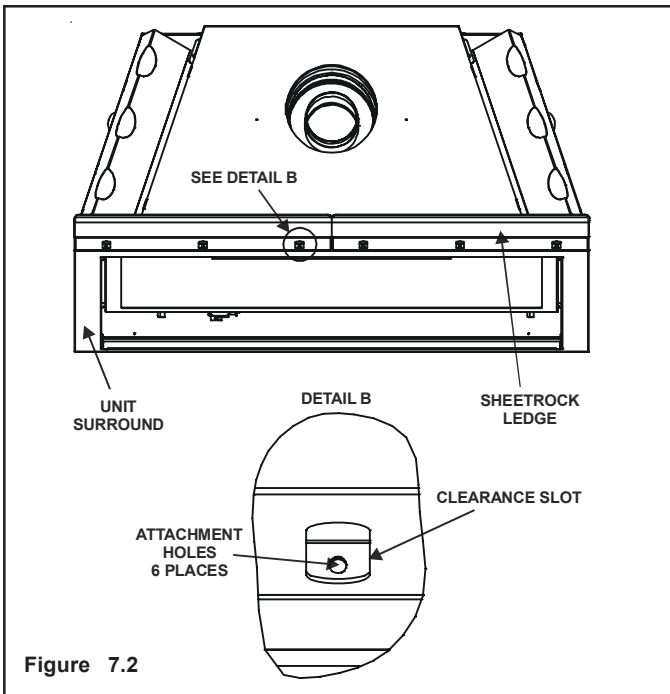

Figure 7.2

Attach sheetrock ledge assembly to the top of the unit using the provided slots. The face of the sheetrock ledge assembly and the unit surround should be flush to each other.

B. Temporary Access Panel

Remove the lower access panel to run the electrical and gas lines to the unit (see Figure 7.3).

Once the electrical and gas lines are hooked up, the lower access panel must be put back on the unit.

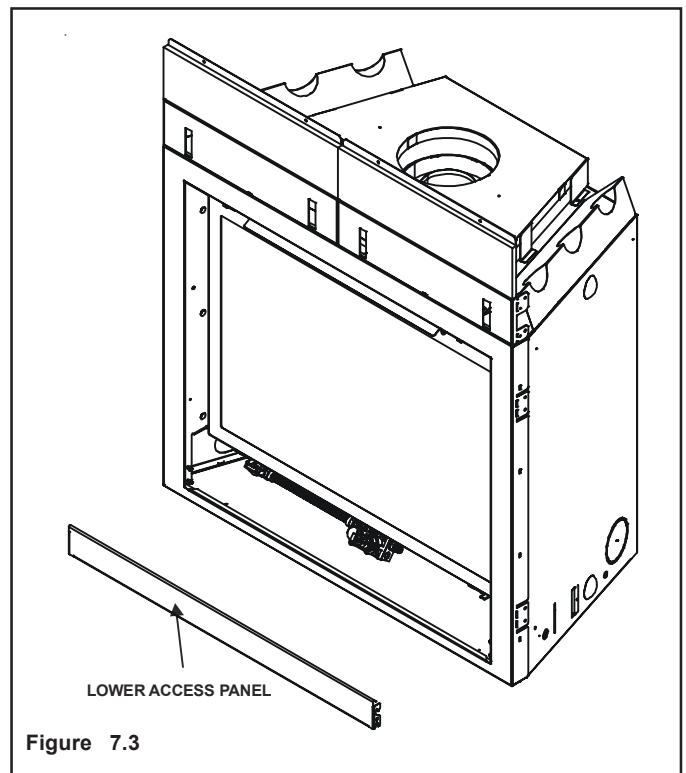

Figure 7.3

C. Securing and Leveling the Appliance

WARNING



Fire Risk.

- Prevent contact with sagging, loose insulation.
- Do NOT install against combustible materials such as exposed insulation, plastic and insulation backer.

The diagram shows how to properly position, level, and secure the appliance (see Figure 7.4). Nailing tabs are provided to secure the appliance to the framing members.

- Place the appliance into position.
- Level the appliance from side to side and front to back.
- Shim the appliance, as necessary. It is acceptable to use wood shims.
- Bend out nailing tabs on each side.
- Keep nailing tabs flush with the framing.
- Secure the appliance to the framing by using nails or screws through the nailing tabs.

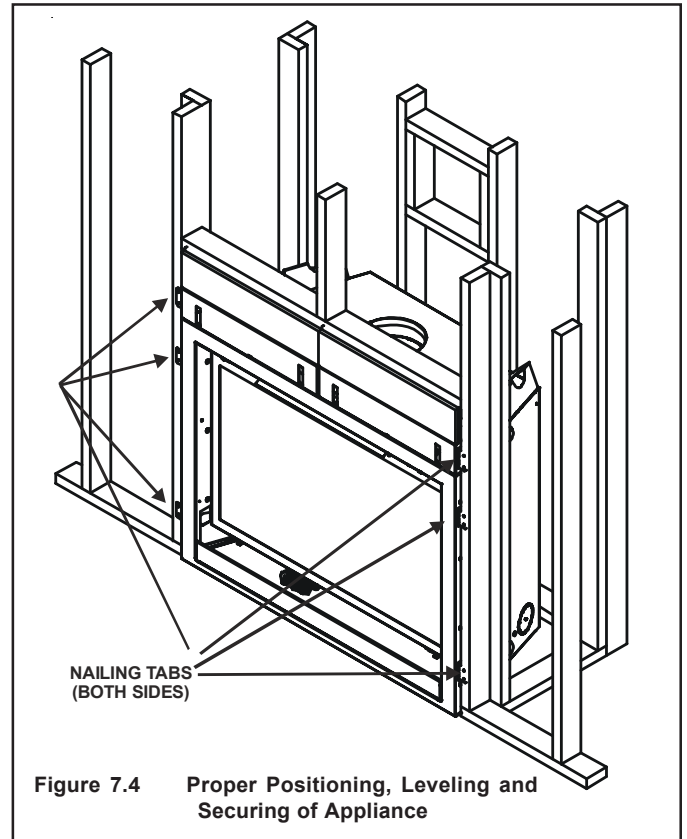

WARNING

Fire Risk.

- ALWAYS maintain specified clearances around the appliance.
 - Do NOT notch into the framing around the appliance spacers.
- Failure to keep insulation, framing or other material away from the appliance may cause fire.



D. Installing the Flue Restrictor

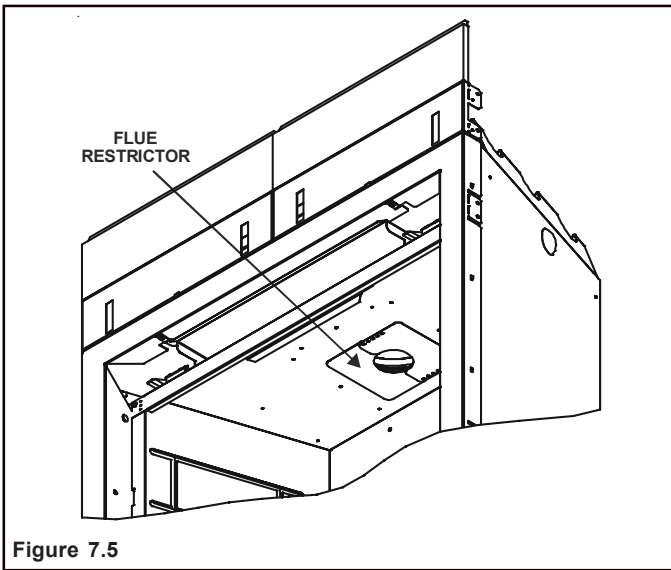

Figure 7.5

1. Break the Flue Restrictor (see Figure 7.5) into two pieces. Do this by bending the part back and forth until it breaks (see Figure 7.6).

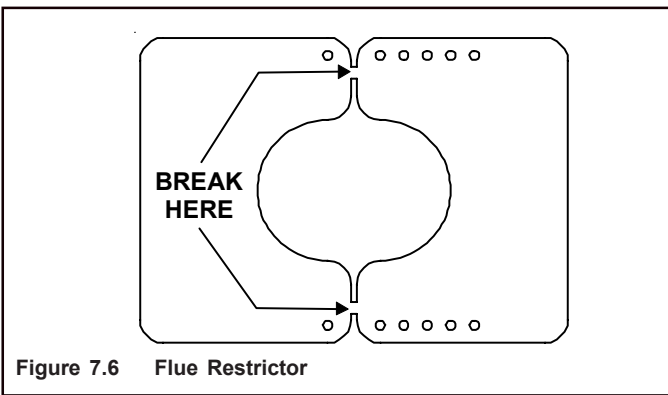

Figure 7.6 Flue Restrictor

2. Match the amount of vertical in the system with the chart to find the appropriate position to set the Flue Restrictor (see Figure 7.7).

- CHART -		
Vertical	Top Vent NG	Top Vent LP
4'	1-1	No Restrictor
8'	2-2	1-2
15'	3-3	3-2
20'	3-4	3-3
25'	3-4	3-3
30'	4-4	3-4
35'	4-4	3-4
40'	5-4	4-4
45'	5-4	4-4
50'	5-4	4-4

Figure 7.7

3. Center the Flue Restrictor on vent and secure in place by using two self-tapping screws (see Figure 7.8).

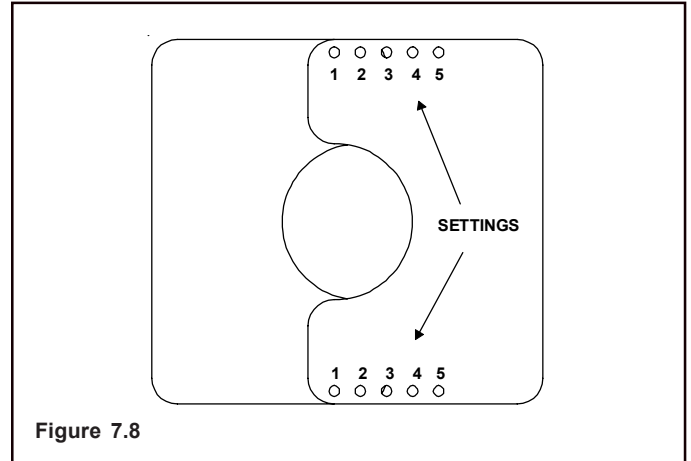

Figure 7.8

E. Installing the Fiberglass Gasket

The fiberglass gasket supplied in the manual bag seals between the first 8 inch (203mm) vent component and the outer fireplace wrap. Using 2 self-tapping screws from the manual bag secure the gasket to the outer wrap (see Figure 7.9).

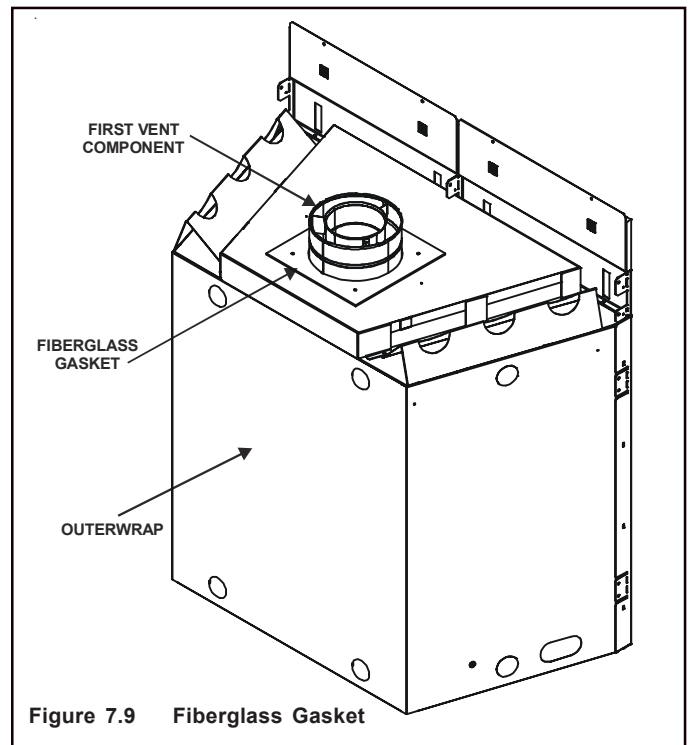



Figure 7.9 Fiberglass Gasket

8

Installing Vent Pipe

A. Assembly of Vent Sections

	WARNING
	<p>Fire Risk Exhaust Fumes Risk Impaired Performance of Appliance</p> <ul style="list-style-type: none">• Overlap pipe slip sections at least 1-1/2 inches• Use pilot holes for screws.• Screws must not exceed one inch long.• Pipe may separate if not properly joined.

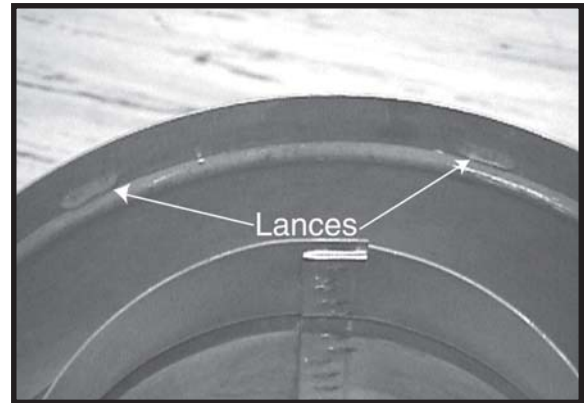

Figure 8.1 Lances

Attaching Vent to the Firebox Assembly

To attach the first pipe section to the collars, slide the male end of the inner vent of the pipe section over the inner collar on the firebox assembly. At the same time, slide the outer flue over the outer collar on the appliance. Push the pipe section into the appliance collar until all the lances (see Figure 8.1) have snapped in place. Tug slightly on the section to confirm it has completely locked into place.

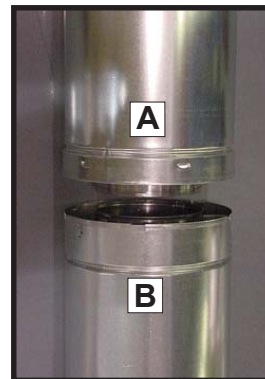

Figure 8.2



Figure 8.3

Assembling Pipe Sections

Insert the inner flue of section A into the flared inner flue of section B.

Start the outer flue of section A over the outer flue of section B (see Figure 8.2). **Note:** The end of the pipe sections with the lances/tabs on it will face towards the appliance.

Once both inner and outer flues are started, press section A onto section B firmly until all lances have snapped into place. Check to make sure they have snapped together (see Figure 8.3) and the seams are not aligned (see Figure 8.4). Tug slightly on section A to confirm it has completely locked into place. It is acceptable to use screws no longer than 1 inch to hold outer pipe sections together. If predrilling holes, do NOT penetrate inner pipe.

For 90° and 45° elbows that are changing the vent direction from horizontal to vertical, one screw minimum should be put in the outer flue at the horizontal elbow joint to prevent the elbow from rotating. Use screws no longer than 1 inch. If predrilling screw holes, do NOT penetrate inner pipe.

Note: Make sure that the seams are not aligned to prevent unintentional disconnection.



CORRECT

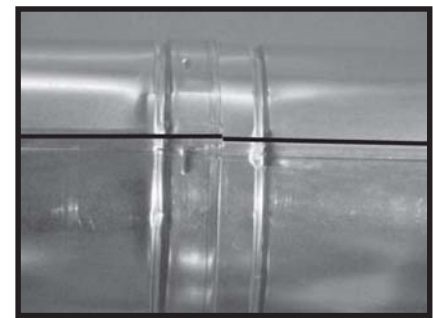

INCORRECT

Figure 8.4 Seams

Assembling Minimum Installations (MI) Sections

MI sections are non-unitized so that they can be cut to a certain length. Cut these sections to length from the non-expanded end (see Figure 8.5).

They can then be attached by first connecting the expanded end of the MI inner flue with the inner pipe from the adjacent pipe section and securing with three screws. The expanded portion of the MI inner flue must overlap completely with the unexpanded end of the adjacent pipe section.

The outer flue can then be inserted into the adjacent outer flue expanded end and attached to the next pipe section with three screws. The other end of the MI pipe section can then be attached by fitting another pipe section to it and snapping it together, as normal.

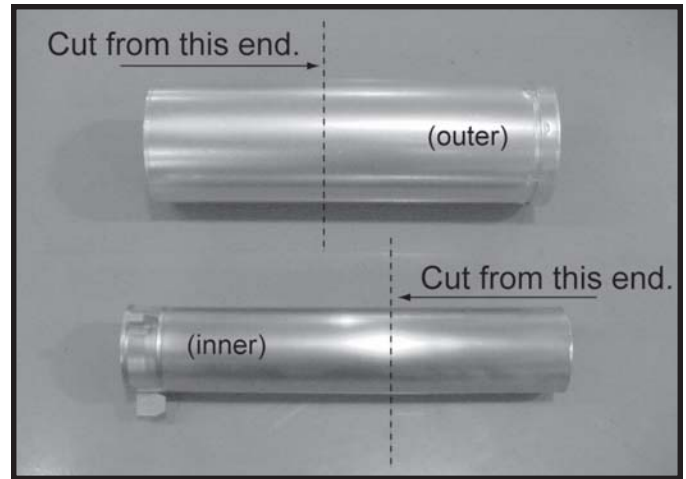

Figure 8.5

Assembling DVP-12A Slip Sections

The outer flue of the slip section should slide over the outer flue of the pipe section and into (inner flue) the last pipe section (see Figure 8.6).

Slide together to the desired length, making sure that a 1-1/2 inch outer flue overlap is maintained between the pipe section and slip section.

The pipe and slip section need to be secured by driving two screws through the overlapping portions of the outer flues using the pilot holes (see Figure 8.7).

This will secure the slip section to the desired length and prevent it from separating. The slip section can then be attached to the next pipe section.

If the slip section is too long, the inner and outer flues of the slip section can be cut to the desired length.

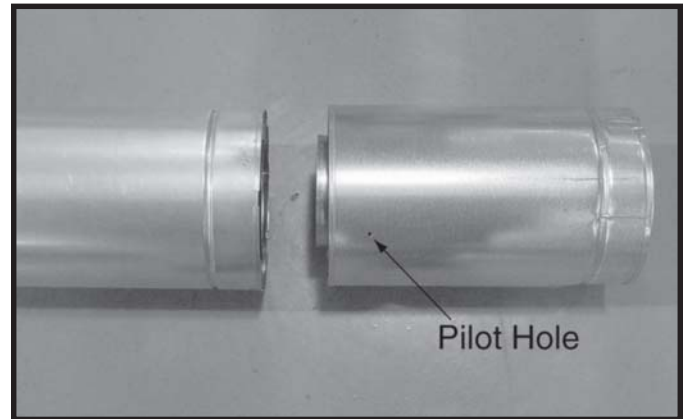

Figure 8.6 Slip Section Pilot Holes

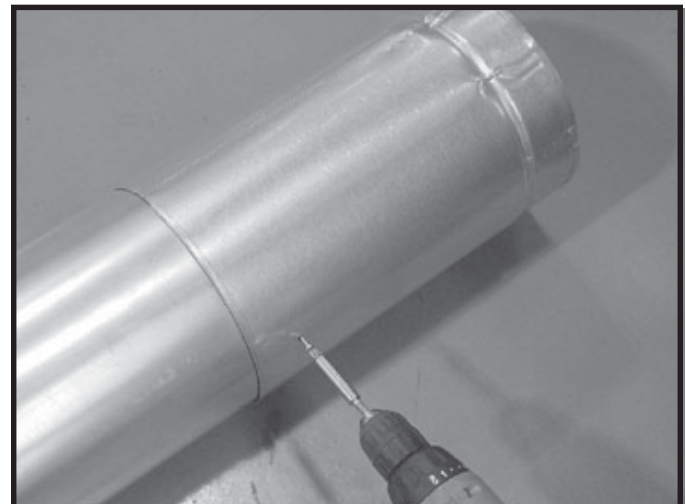

Figure 8.7 Screws into Slip Section

Securing the Vent Sections

Vertical Sections

Vertical sections of pipe must be supported every 8 feet after the 25 foot maximum unsupported rise. The vent support or plumber's strap (spaced 120° apart) may be used to do this (see Figure 8.8).

Horizontal Sections

Horizontal sections of vent must be supported every 5 feet with a vent support or plumber's strap.

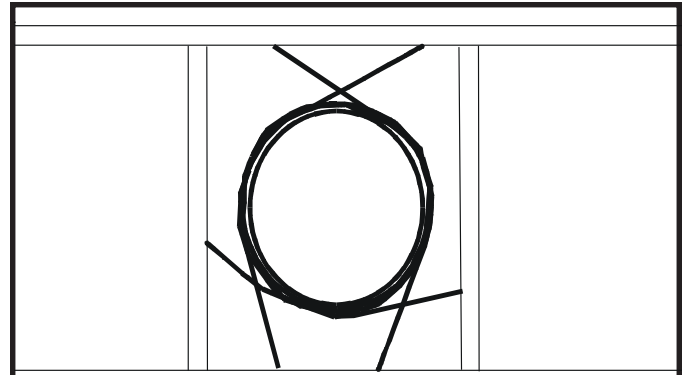

Figure 8.8 Securing Vertical Pipe Sections

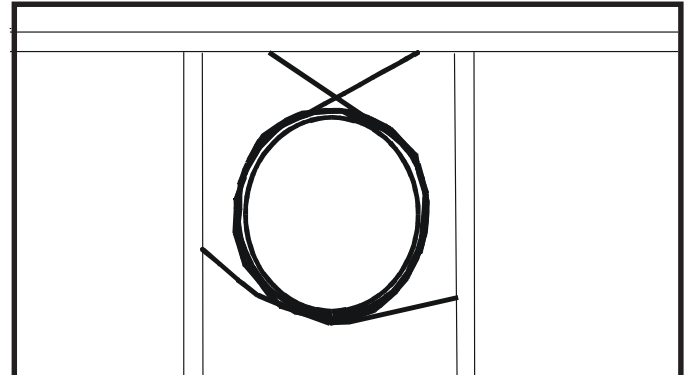





Figure 8.9 Securing Horizontal Pipe Sections

B. Disassembly of Vent Sections

To disassemble any two pieces of pipe, rotate either section (see Figure 8.10), so that the seams on both pipe sections are aligned (see Figure 8.11). They can then be carefully pulled apart.

 WARNING	
	Fire Risk. Explosion Risk. Combustion Fume Risk.
	Use vent run supports per installation instructions. Connect vent sections per installation instructions.
	<ul style="list-style-type: none">• Maintain all clearances to combustibles.• Do NOT allow vent to sag below connection point to appliance.
Improper support may allow vent to sag or separate.	

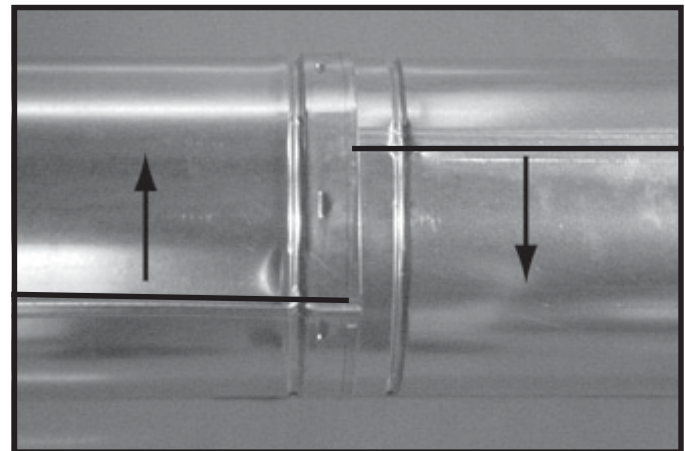

Figure 8.10 Rotate Seams for Disassembly

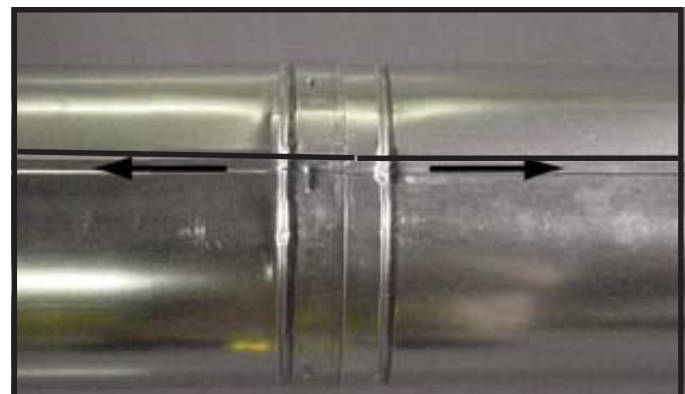





Figure 8.11 Align and Disassemble Vent Sections

C. Installing Heat Shield and Horizontal Termination Cap

	WARNING
<p>Fire Hazard Impaired performance of appliance</p> <ul style="list-style-type: none"> Telescoping flue section of termination cap MUST be used when connecting pipe section to termination cap. Maintain a 1-1/2 inch minimum overlap on telescoping flue section of termination cap. 	

	WARNING
<p>Fire Risk Exhaust Fumes Risk Impaired Performance of Appliance</p> <ul style="list-style-type: none"> Overlap pipe slip sections at least 1-1/2 inches. Use pilot holes for screws. Screws must not exceed 1 inch long. Pipe may separate if not properly joined. 	
	

Heat Shield Requirements for Horizontal Termination

For all horizontally vented appliances, a heat shield **MUST** be placed one inch above the top of the vent between the wall shield firestop and the base of the termination cap.

There are two sections of the heat shield. One section attaches to the wall shield firestop with two screws. The remaining section is attached to the cap in the same manner.

If the wall thickness does not allow the required 1-1/2 inch heat shield overlap, an extended heat shield must be used.

The extended heat shield will need to be cut to the thickness of the wall and be attached to the wall shield firestop. The small leg on the extended heat shield should rest on the top of the vent (pipe section) to properly space it from the pipe section (see Figure 8.12).

Installing the Horizontal Termination Cap

Vent termination must not be recessed in the wall. Siding may be brought to the edge of the cap base.

Flash and seal as appropriate for siding material at outside edges of cap. ←

When installing a horizontal termination cap, follow the cap location guidelines as prescribed by current **ANSI Z223.1** and **CAN/CGA-B149** installation codes.

	WARNING
<p>Burn Risk</p> <ul style="list-style-type: none"> Local codes may require installation of a cap shield to prevent anything or anyone from touching the hot cap. 	

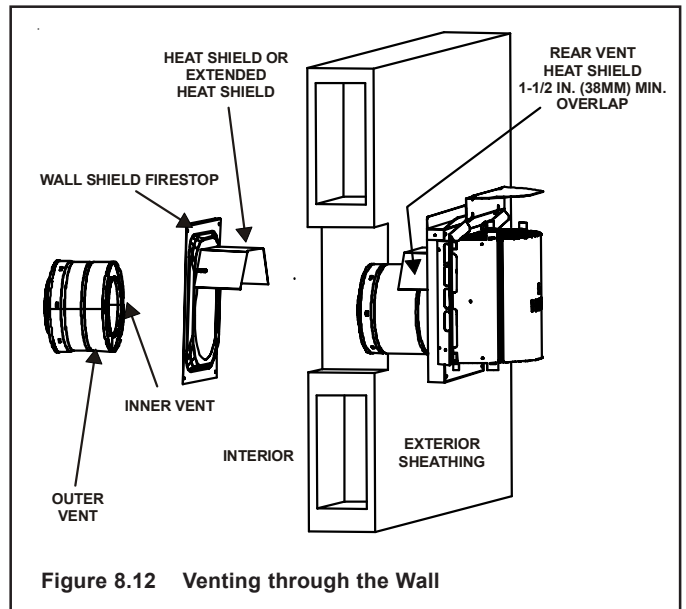

Figure 8.12 Venting through the Wall

NOTE: Where required, an exterior wall flashing is available.

When penetrating a brick wall, a brick extension kit is available for framing the brick.

D. Installing Roof Flashing and Vertical Termination Cap

To install roof flashing see Figure 8.13.

For installation of vertical termination cap see minimum vent heights for various pitched roofs (see Figure 8.13) .

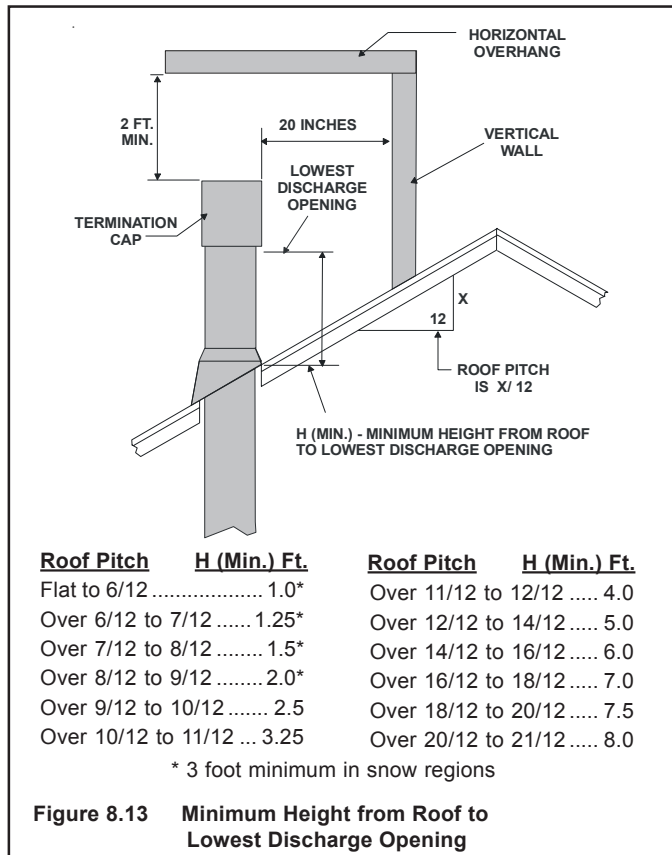

To attach the vertical termination cap, slide the inner collar of the cap into the inner flue of the pipe section and place the outer collar of the cap over the outer flue of the pipe section.

Secure with three screws into the outer flue. Secure the cap by driving the three self-tapping screws (supplied) through the pilot holes in the outer collar of the cap into the outer flue of the pipe (see Figure 8.14).

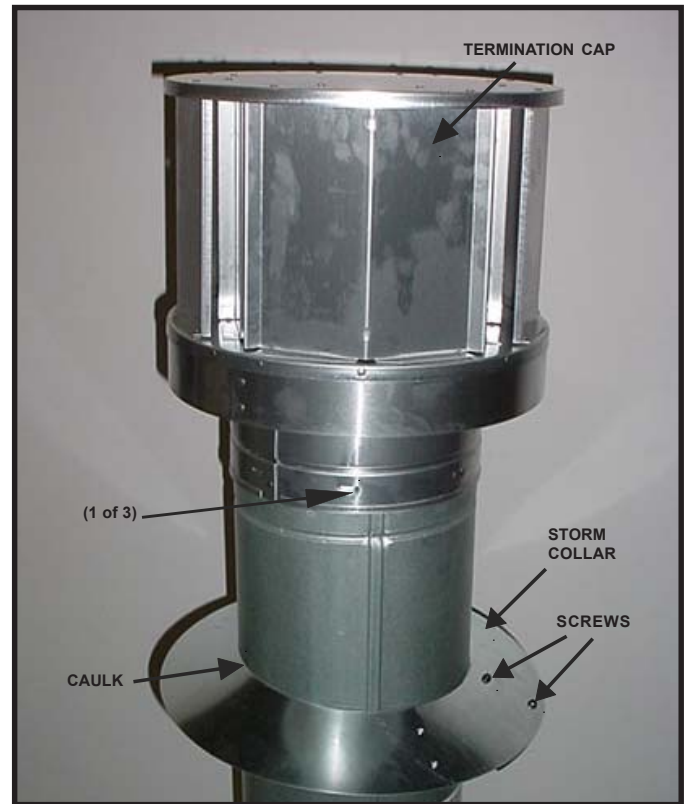

Figure 8.14



WARNING

Fire Risk.
Explosion Risk.

Inspect external vent cap regularly.

- Ensure no debris blocks cap.
- Combustible materials blocking cap may ignite.
- Restricted air flow affects burner operation.

Assembling and Installing Storm Collar

CAUTION	
	<p>Sharp Edges</p> <ul style="list-style-type: none">• Wear protective gloves and safety glasses during installation.
	

Connect both halves of the storm collar with two screws (see Figure 8.15).

Wrap the storm collar around the exposed pipe section and align brackets. Insert a bolt (provided) through the brackets and tighten nut to complete storm collar assembly (see Figure 8.16).

Slide the assembled storm collar down the pipe section until it rests on the roof flashing.

Caulk around the top of the storm collar (see Figure 8.14).

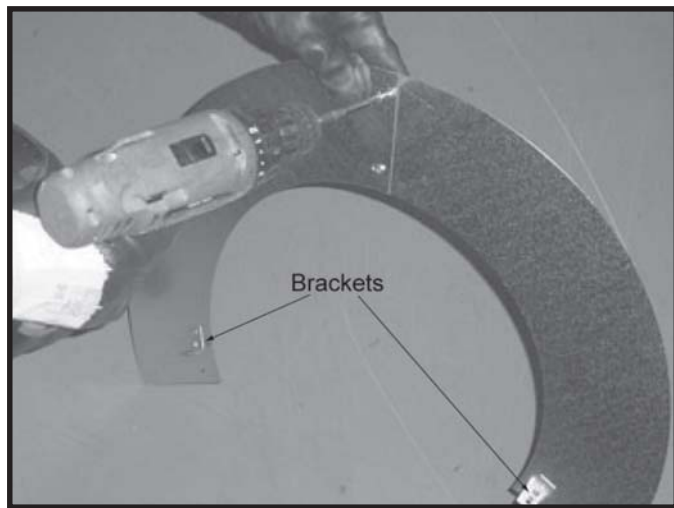

Figure 8.15 Assembling the Storm Collar

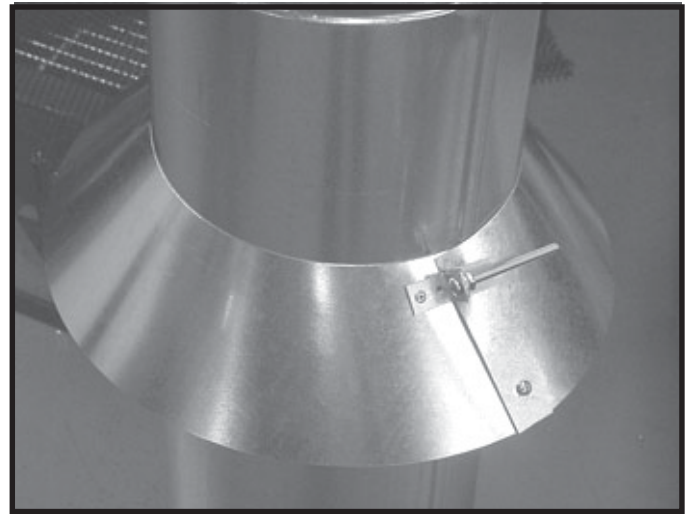

Figure 8.16 Assembling the Storm Collar Around the Pipe

9

Gas Information

A. Fuel Conversions

Before making gas connections ensure that appliance being installed is compatible with the available gas type.

Any natural or propane gas conversions necessary to meet the appliance and locality needs must be made by a qualified technician using Hearth & Home Technologies specified and approved parts.

B. Gas Pressures

Proper input pressures are required for optimum appliance performance. Gas line sizing requirements need to be made following NFPA51.





WARNING



Fire Risk.
Explosion Hazard.
High pressure will damage valve.

- Disconnect gas supply piping BEFORE pressure testing gas line at test pressures above 1/2 psig.
- Close the manual shutoff valve BEFORE pressure testing gas line at test pressures equal to or less than 1/2 psig.





WARNING



Verify inlet pressures.

- High pressure may cause overfire condition.
- Low pressure may cause explosion.
- Verify minimum pressures when other household gas appliances are operating.

Install regulator upstream of valve if line pressure is greater than 1/2 psig.



Pressure requirements for appliance are shown in the table below. Minimum pressures must be met when other household gas appliances are operating.

Pressure	Natural Gas	Propane
Minimum Inlet Pressure	5.0 inches w.c.	11.0 inches w.c.
Maximum Inlet Gas Pressure	14.0 inches w.c.	14.0 inches w.c.
Manifold Pressure	3.5 inches w.c.	10.0 inches w.c.

C. Gas Connection

NOTE: Have the gas supply line installed in accordance with local building codes, if any. If not, follow ANSI 223.1. Installation should be done by a qualified installer approved and/or licensed as required by the locality. (In the Commonwealth of Massachusetts installation must be performed by a licensed plumber or gas fitter.)

NOTE: A listed (and Commonwealth of Massachusetts approved) 1/2 inch (13mm) T-handle manual shut-off valve and flexible gas connector are connected to the 1/2 inch (13mm) control valve inlet.

- If substituting for these components, please consult local codes for compliance.**

Refer to Reference Section 16 for location of gas line access in appliance.

NOTE: Gas line may be run from either side of the appliance provided the hole in the outer wrap does NOT exceed 2-1/2 inches in diameter and does not penetrate the firebox.



WARNING





Gas Leak Risk



- Support control when attaching pipe to prevent bending gas line.

NOTE: The gap between supply piping and gas access hole may be caulked with high temperature caulk or stuffed with non-combustible, un-faced insulation to prevent cold air infiltration.

- Ensure that gas line does not come in contact with outer wrap of appliance. Follow local codes.
- Incoming gas line should be piped into the valve compartment and connected to the 1/2 inch connection on the manual shutoff valve.

	WARNING
	<p>Fire or Explosion Hazard</p> <ul style="list-style-type: none"> • Gas build-up during line purge may ignite. • Purge should be performed by qualified technician. • Ensure adequate ventilation. • Ensure there are no ignition sources such as sparks or open flames.

- A small amount of air will be in the gas supply lines. When first lighting appliance it will take a short time for air to purge from lines. When purging is complete the appliance will light and operate normally.

	WARNING
	<p>CHECK FOR GAS LEAKS</p> <p>Explosion Risk Fire Risk Asphyxiation Risk</p> <ul style="list-style-type: none"> • Check all fittings and connections. • Do not use open flame. • After the gas line installation is complete, all connections must be tightened and checked for leaks with a commercially-available, non-corrosive leak check solution. Be sure to rinse off all leak check solution following testing. <p>Fittings and connections may have loosened during shipping and handling.</p>

	WARNING
	<p>Fire hazard.</p> <p>Do NOT change the valve settings.</p> <ul style="list-style-type: none"> • This valve has been preset at the factory. • Changing valve settings may result in fire hazard or bodily injury.

HIGH ALTITUDE INSTALLATIONS

U.L. Listed gas appliances are tested and approved without requiring changes for elevations from 0 to 2000 feet in the U.S.A. and Canada.

When installing this appliance at an elevation above 2000 feet, it may be necessary to decrease the input rating by changing the existing burner orifice to a smaller size. Input rate should be reduced by 4% for each 1000 feet above a 2000 foot elevation in the U.S.A., or 10% for elevations between 2000 and 4500 feet in Canada. If the heating value of the gas has been reduced, these rules do not apply. To identify the proper orifice size, check with the local gas utility.

If installing this appliance at an elevation above 4500 feet (in Canada), check with local authorities.

10

Electrical Information

A. Recommendation for Wire

This appliance requires 110-120 VAC be wired to the junction box either for proper operation of the appliance.

NOTE: This appliance must be electrically wired and grounded in accordance with local codes or, in the absence of local codes, with **National Electric Code ANSI/NFPA 70-latest edition** or the **Canadian Electric Code, CSA C221.1**.

B. Connecting to the Appliance

	WARNING Wire 110V to electrical junction box. Do NOT wire 110V to valve. Do NOT wire 110V to wall switch. <ul style="list-style-type: none">• Incorrect wiring will damage millivolt valves.• Incorrect wiring will override IPI safety lockout and may cause explosion.
---	---

- This appliance may be used with a wall switch, wall mounted thermostat and/or a remote control.
- If using thermostat use one compatible with a millivolt gas valve system.
- Follow parameters for locating thermostat (see individual thermostat instructions) to ensure proper operation of appliance.
- Use low resistance thermostat wire for wiring from ignition system to the wall switch and thermostat.
- Keep wire lengths short as possible by removing any excess wire length.
- Low voltage and 110 VAC voltage cannot be shared within the same wall box.

C. Intellifire Ignition System Wiring

This appliance requires a 110 VAC supply to the appliance junction box for operation. A wiring diagram is shown in Figure 10.1.

This appliance is equipped with an Intellifire control valve which operates on a 3 volt system.

This appliance is supplied with a battery pack and a 3 volt AC transformer, which requires the installation of the supplied junction box. It is highly recommended that the junction box be installed at this time to avoid reconstruction.

The battery pack requires two D cell batteries (not included).

NOTE: Batteries cannot be placed in the battery pack while using the 3 volt AC transformer. The transformer must be unplugged if the battery pack is used or battery life will be reduced.

CAUTION

Battery polarity must be correct or module damage will occur.

Optional Accessories Requirements

Wiring for optional accessories should be done now to avoid reconstruction.

CAUTION

Label all wires prior to disconnection when servicing controls. Wiring errors can cause improper and dangerous operation. Verify proper operation after servicing.

	WARNING Shock hazard. <ul style="list-style-type: none">• Replace damaged wire with type 105° C rated wire.• Wire must have high temperature insulation.
---	---

D. Wall Switch

Position the wall switch in the desired position on the wall. An assembly of 18 ft of 20 AWG is provided with the fire-place to connect the wall switch to the appliance. Instead of the supplied assembly, wire with a length of 25 ft or less and a gauge of 20 AWG through 14 AWG is acceptable. The wire needs a jacket with a temperature rating of 140°F (60°C) or higher. At the appliance connect the wire to the ON/OFF switch pigtailed.

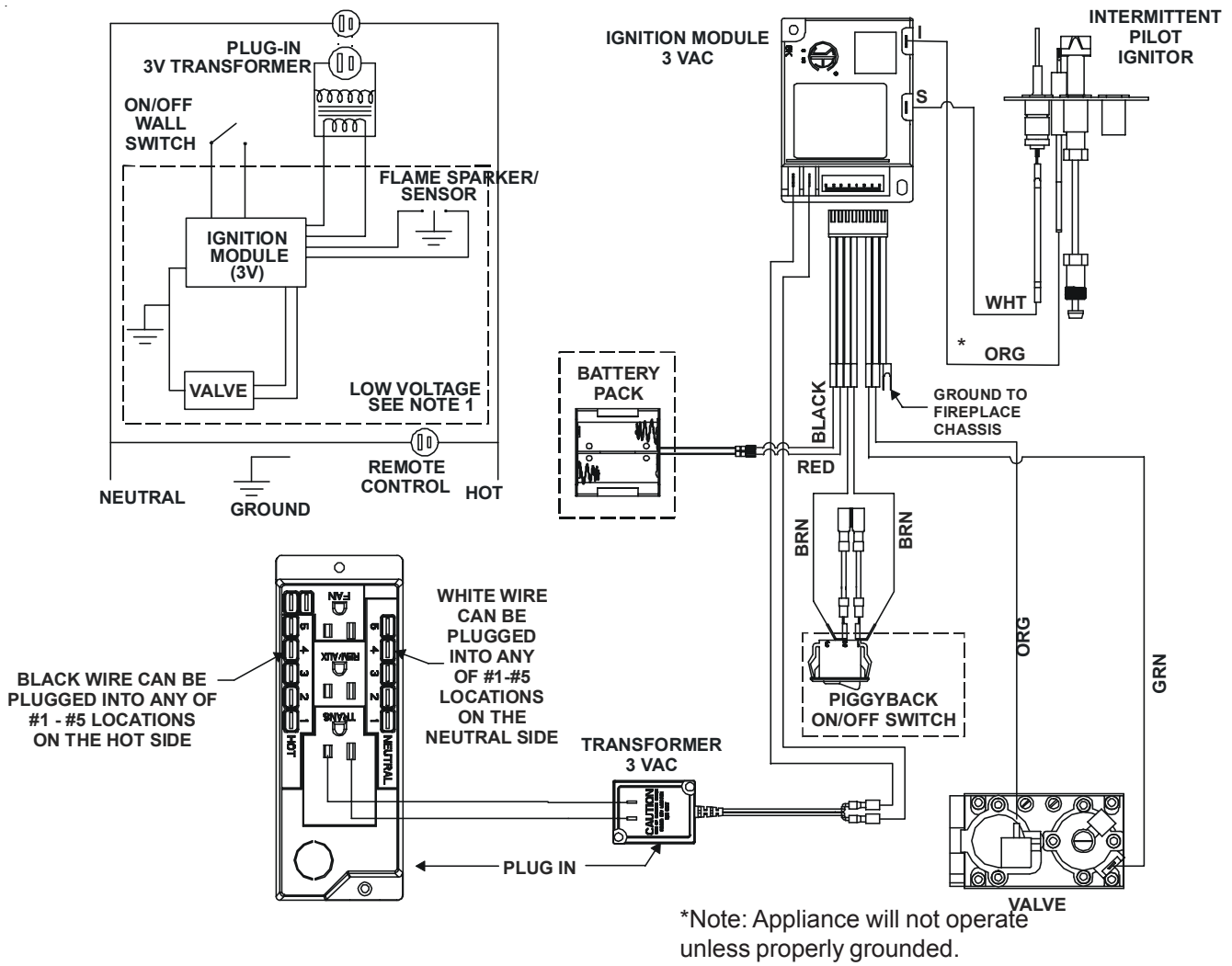
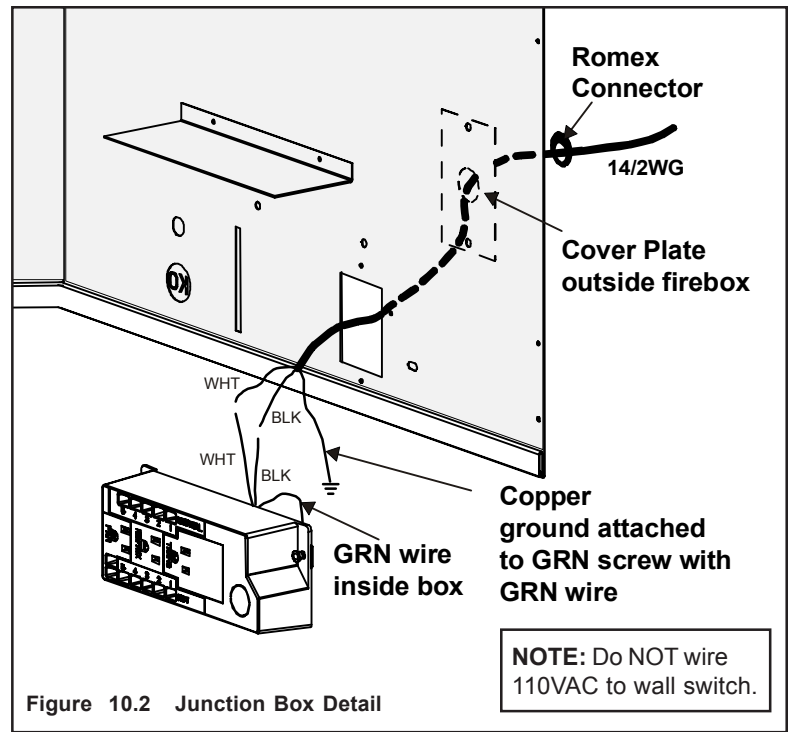

Figure 10.1 Intellifire Pilot Ignition (IPI) Wiring Diagram

E. Junction Box Installation

If the box is being wired from the appliance:

- Remove the screw attaching the junction box to the outer shell, rotate the junction box inward to disengage it from the outer shell (see Figure 10.2).
- Pull the electrical wires from outside the appliance through this opening into the valve compartment.
- Loosen the two screws on the Romex connector (not included with unit), feed the necessary length of wire through the connector and tighten the screws.
- Make all necessary wire connections to the receptacle and assemble the receptacle and cover to the junction box.



F. Wall Switch Installation for Fan (Optional)

If the box is being wired to a wall mounted switch for use with a fan (See Figure 10.3):

- The power supply for the appliance must be brought into a switch box.
- The power can then be supplied from the switch box to the appliance using a minimum of 14-3 with ground wire.
- At the switch box connect the black (hot) wire and red (switch leg) wire to the wall switch as shown.
- At the appliance connect the black (hot), white (neutral) and green (ground) wires to the junction box as shown.
- Add a 1/4 inch insulated female connector to the red (switch leg) wire, route it through the knockout in the face of the junction box, and connect to the top fan switch connector (1/4 inch male) as shown.

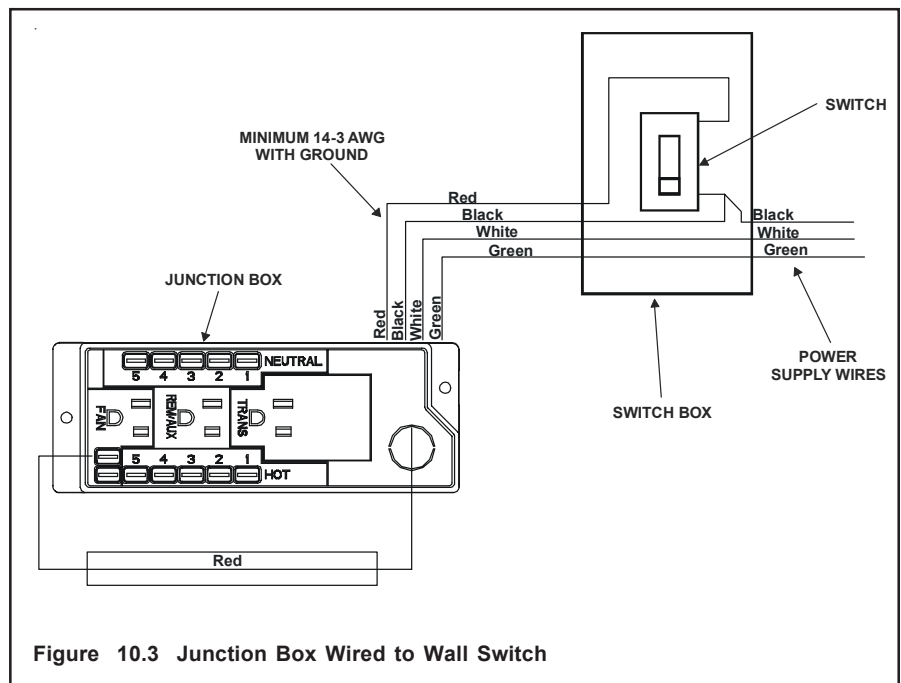

11

Finishing

A. Mantel Projections

Figure 11.1 shows the minimum vertical and corresponding maximum horizontal dimensions of appliance mantels or other combustible projections above the top front edge of the appliance.

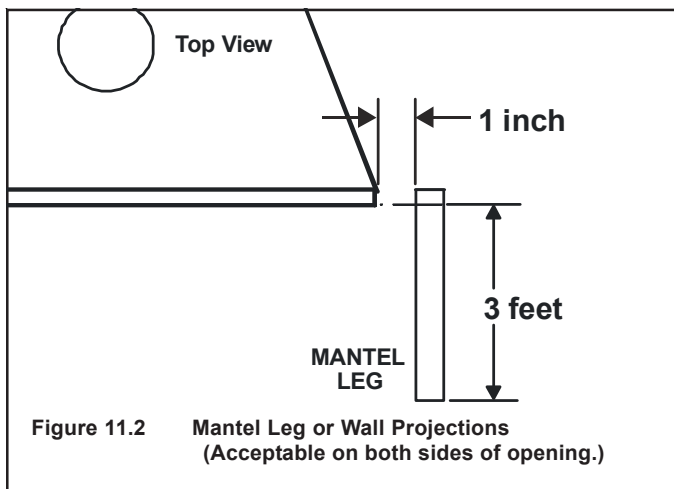
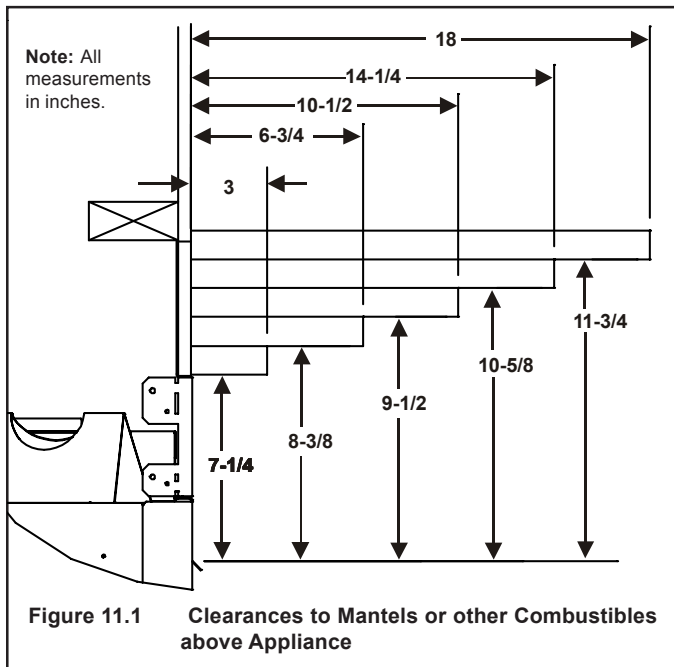

B. Facing Material

WARNING

Fire Risk
Explosion Risk

• Facing and/or finishing materials must never overhang into the glass opening.

- Overhanging materials may ignite.
- May interfere with proper operation of glass assembly.

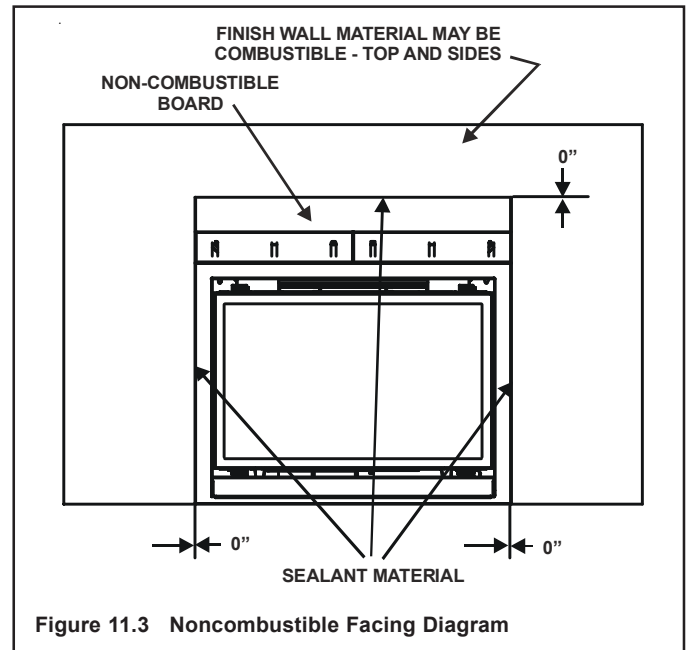

WARNING

Risk of Fire

- Non-combustible clearances must be maintained.
- Sheetrock, wood or other combustibles must NOT be used as sheathing or facing in the non-combustible zone.
- See **Section 11** for proper clearances.
- See **Section 1** for combustible/non-combustible definitions.

WARNING

Fire Risk.

Finish all edges and fronts to clearances and specifications listed in manual.

- Black metal appliance front may be covered with non-combustible material only.
- Do NOT overlap combustible materials onto appliance front.
- Install combustible materials up to specified clearances on top front and side edges.
- Seal joints between the finished wall and appliance top and sides using only a 300°F minimum sealant.

12

Appliance Setup

A. Remove Shipping Materials

Remove shipping materials from inside or underneath the firebox.

B. Clean the Appliance

Clean/vacuum any sawdust that may have accumulated inside the firebox or underneath in the control cavity.

C. Accessories

Install approved accessories per instructions included with accessories. See Service Parts List for appropriate accessories. Refer to **Section 16**.

Removing Optional GFK-160A Fan

ITEM

- 1 - Remove front from the fireplace (see Figure 12.1).
- 2 - Remove glass assembly from the fireplace (see Figure 12.1).
- 3 - Remove logs.
- 4 - Remove grate (see Figure 12.1).
- 5 - Remove side and back refractory.
- 6 - Remove burner assembly (see Figure 12.1).
- 7 - Remove valve assembly (see Figure 12.1).
- 8 - Disconnect fan and remove it through the valve assembly cavity (see Figure 12.2).

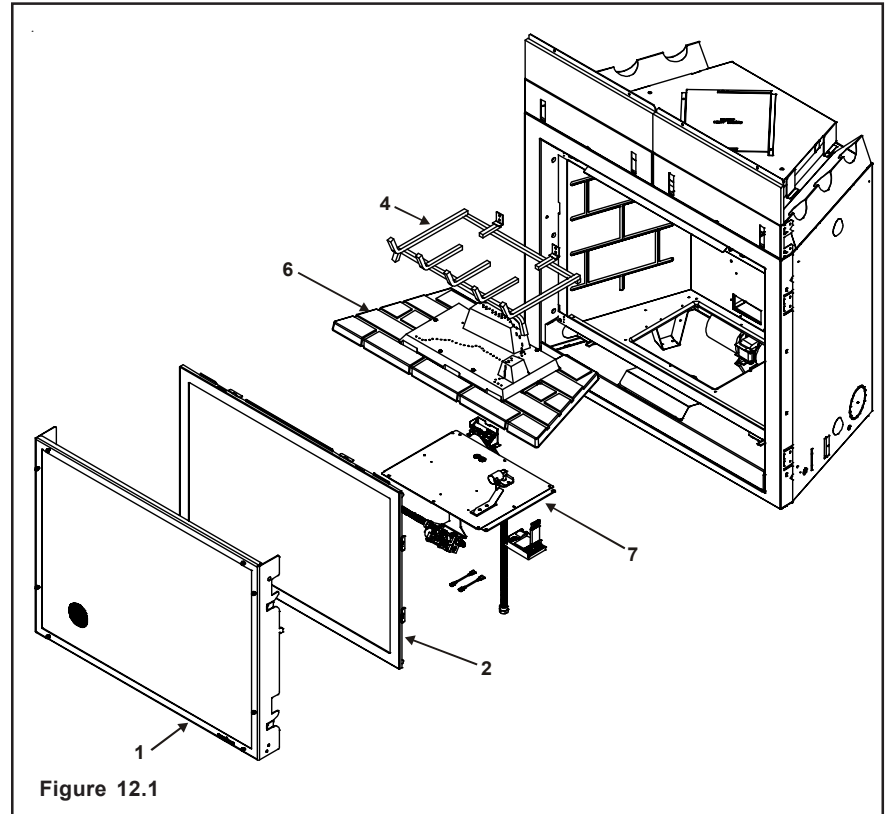

Figure 12.1

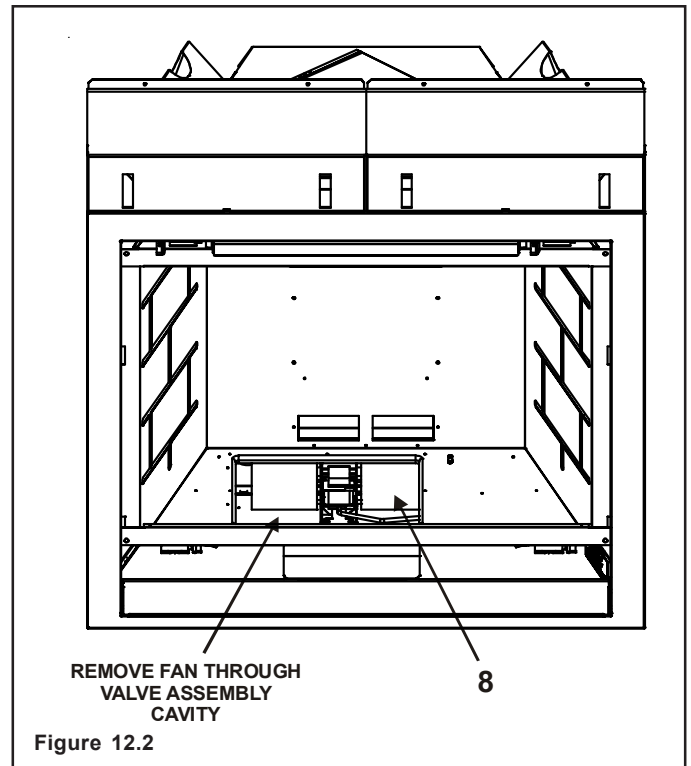
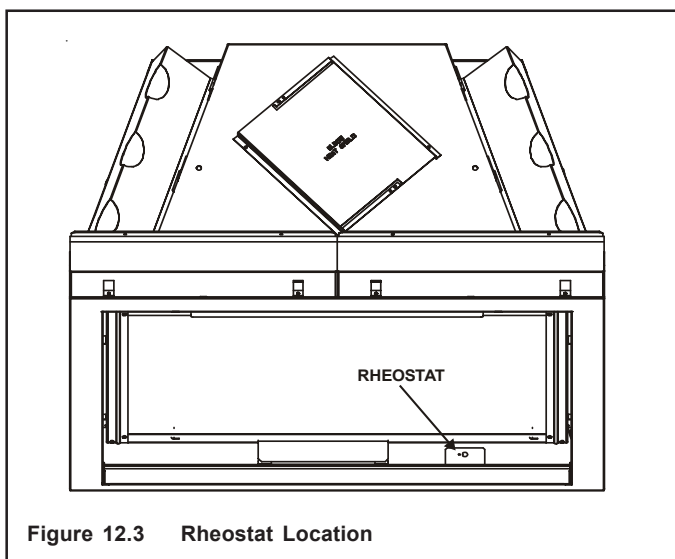

Figure 12.2



→ Figure 12.3 Rheostat Location

	WARNING
<p>Shock or fire risk. Use ONLY optional accessories approved for this appliance.</p> <ul style="list-style-type: none"> • Using non-listed accessories voids warranty. • Using non-listed accessories may result in a safety hazard. • Only Hearth & Home Technologies approved accessories may be used safely. 	

D. Install the Refractory

Install refractory following instructions located in the manual bag.

E. Ember Placement

	WARNING
<p>Explosion Risk.</p> <ul style="list-style-type: none"> • Follow ember placement instructions in manual. • Do NOT place embers directly over burner ports. • Replace ember material annually. <p>Improperly placed embers interferes with proper burner operation.</p>	

Placing the Ember Material

Ember material is shipped with this gas appliance. To place the ember material:

- Embers **CANNOT** be placed directly over ports. Care should be taken not to cover the lighting trail of ports (from back to front).
- When placing Glowing Embers[®] onto the burner care should be taken so that the ports are not covered. Place the dime-size ember pieces just in front of the port trail, but not on or in between the ports (see Figure 12.3). Failure to follow this procedure will likely cause lighting and sooting problems.

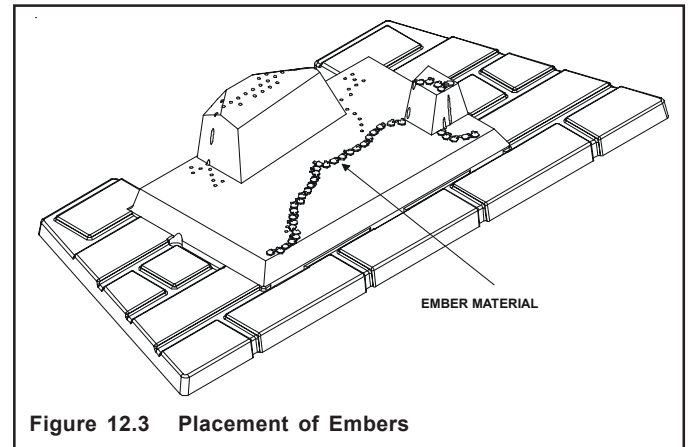

Figure 12.3 Placement of Embers

- Place Mystic Embers on areas of base refractory away from port holes. Use this material to give the appliance a realistic ash bed.
- Save the remaining ember materials for use during appliance servicing. The embers provided should be enough for 3 to 5 applications.

F. Positioning the Logs

If the gas logs have been factory installed they should not need to be positioned. If the logs have been packaged separately, refer to the following instructions.

Log Assembly: LOGS-6OAK



Figure 12.4

CAUTION: Carefully remove the logs from the packaging. Logs are fragile!

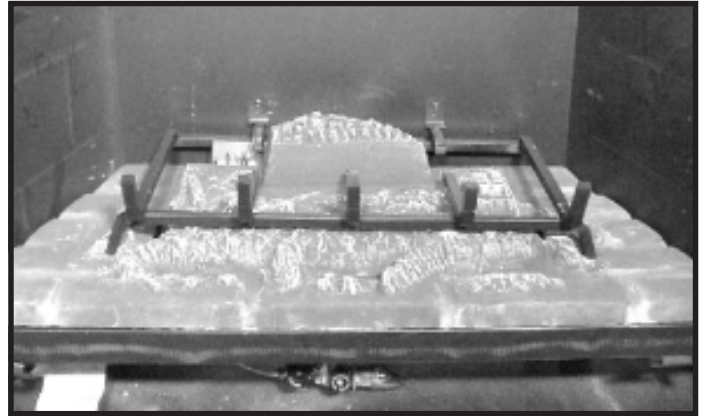

Figure 12.5

STEP 1. Remove the metal grate support which is stabilizing the grate for shipping purposes.

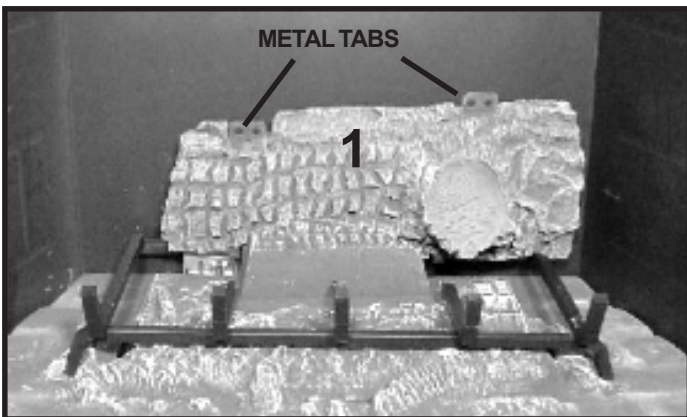

Figure 12.6

STEP 2. LOG #1 (SRV385-720): Place the log so that the notches on the bottom of log line up with the grate bars. Note: There should be about 1/4" gap between the log and the hump on the burner.

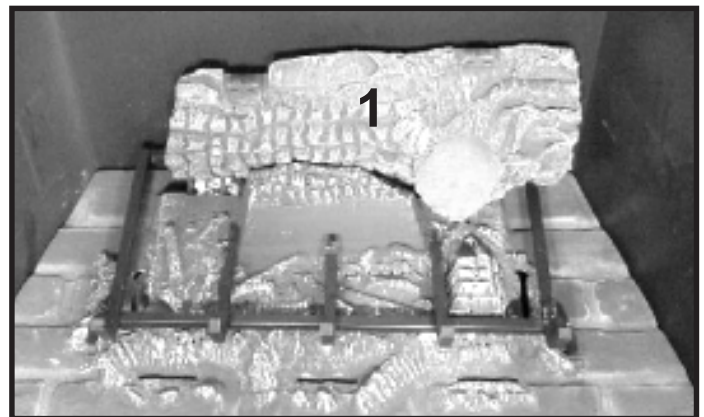

Figure 12.7

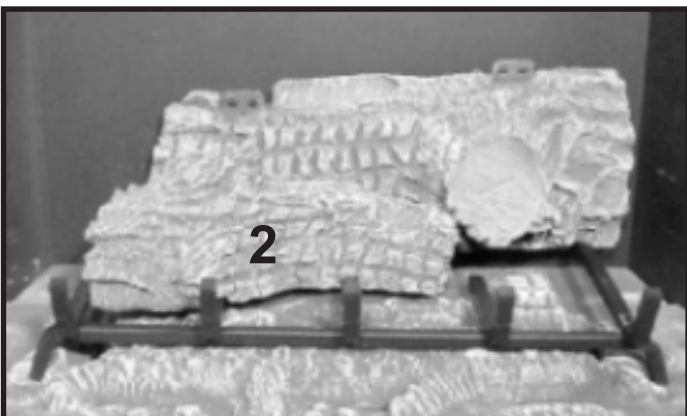

Figure 12.8

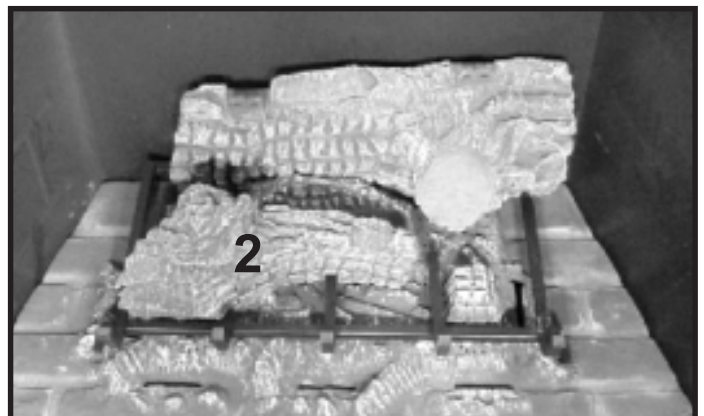

Figure 12.9

STEP 3. LOG #2 (SRV385-724): Place this log so that the notches on the bottom of the log line up with the grate bars and slide it into the firebox until it hits the hump on the burner.

383-935B

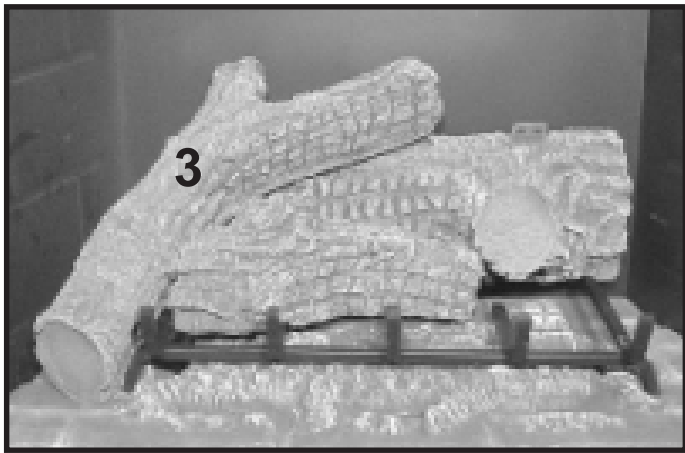

Figure 12.10

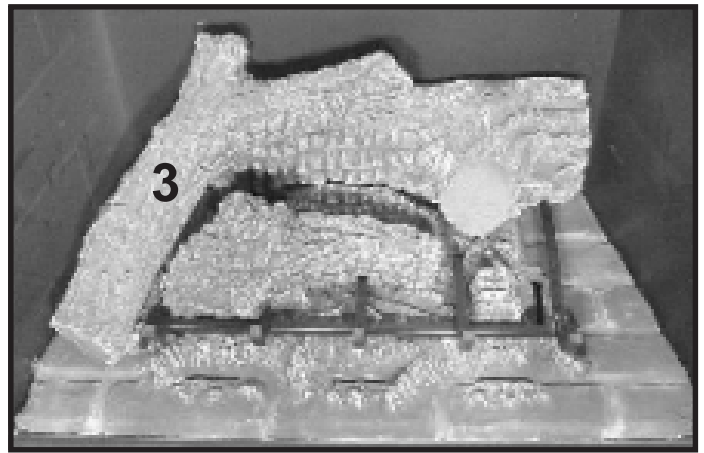

Figure 12.11

STEP 4. LOG #3 (SRV385-721): Locate the slot in the underside of this log. Place this log so that this slot fits onto the left metal tab on log #1. Swing the lower end of this log towards the log grate so it touches the grate.



Figure 12.12

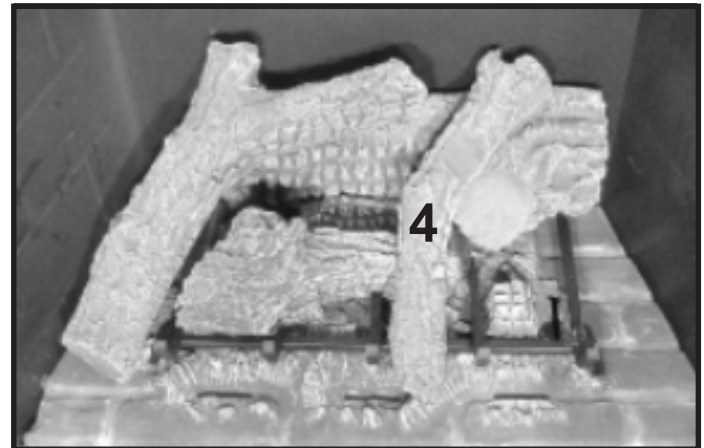

Figure 12.13

STEP 5. LOG #4 (SRV385-723): Locate the slot in the underside of this log. Place the log so that this slot fits onto the right metal tab on log #1. Swing the lower end so that it sits in or above the dent on the top of log #2.



Figure 12.14



Figure 12.15

STEP 6. LOG #5 (SRV385-722): Place this log so that the notch in the underside of this log is positioned onto the right grate bar, even with the grate leg. Swing the top portion of the log so it will rest on the dent of log #4.

G. Glass Assembly

WARNING

- Handle glass doors with care.
- Inspect the gasket to ensure it is undamaged.
- Inspect the glass for cracks, chips or scratches.

- Do NOT strike, slam or scratch glass.
- Do NOT operate appliance with glass door removed, cracked, broken or scratched.
- Replace glass door assembly as a complete appliance.

Removing Glass Assembly

Pull the four glass assembly latches out of the groove on the glass frame. Remove glass door from the appliance (see Figure 12.16).

Replacing Glass Assembly

Replace the glass door on the appliance. Pull out and latch the four glass assembly latches into the groove on the glass frame.

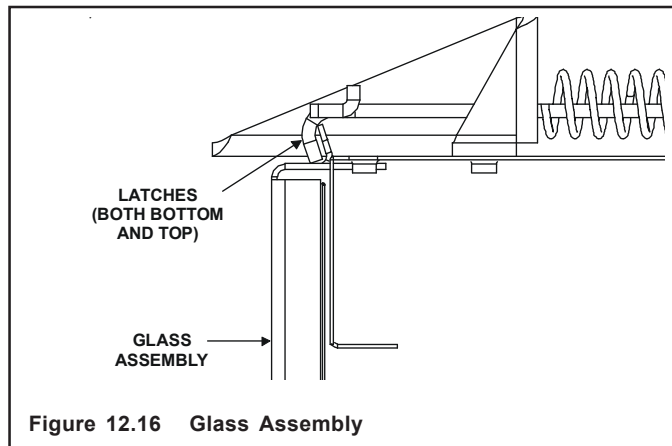

Figure 12.16 Glass Assembly

H. Screen Mesh

The screen mesh is built into front.

I. Grilles and Trim

Install optional marble and brass trim surround kits as desired. Marble, brass, brick, tile, or other non-combustible materials can be used to cover up the gap between the sheet rock and the appliance.

Do not obstruct or modify the air inlet/outlet grilles. When overlapping on both sides, leave enough space so that the bottom grille can be lowered and the trim door removed.

J. Hood

Hood is included with the front and required in all installations.

K. Air Shutter Setting

This appliance has an adjustable air shutter (which controls the primary air) factory set for the minimum vertical vent run (see Figure 12.17). If your installation has more than the minimum required vertical vent length, adjustment of the air shutter may be necessary to obtain optimal flame appearance. **This should be adjusted by a qualified installer at the time of installation.**

By pushing the air shutter handle in, you will be closing the air shutter. To adjust loosen the wing nut. Care should be taken when adjusting the air shutter so as not to cause the appliance to soot. If sooting occurs the air shutter will need to be opened by pulling the handle out. When finished tighten wing nut.

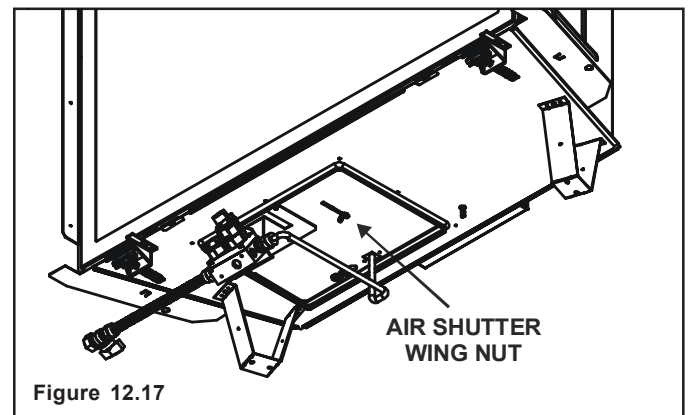

Figure 12.17

Shutter Settings

	NG	LP
Burner	1/8 in.	5/8 in.

13

Operating Instructions

A. Before Lighting Appliance

CAUTION

If installing Intellifire ignition battery backup:

- Do not install batteries if the backup mode may not be used for extended time.
- Batteries may leak.
- Install batteries only when needed for power outage.

Before operating this appliance have a qualified technician:

- Remove all shipping materials from inside and/or underneath the firebox.
- Review proper placement of logs, rockwool, lava rock, and vermiculite.
- Check the wiring.
- Check the air shutter adjustment.
- Ensure that there are no gas leaks.
- Ensure that the glass is sealed and in the proper position.
- Ensure that the flow of combustion and ventilation air is not obstructed (front grilles and vent caps).



WARNING

Glass door must be in place when appliance is operating.

Risk of:

- Combustion Fumes
- Fire



Do NOT operate appliance with glass door removed.

- Open viewing glass for servicing only.
- Glass door MUST be in place and sealed before operating appliance.
- Only use glass door certified for use with appliance.
- Glass replacement should be done by qualified technician.



WARNING

**HOT! DO NOT TOUCH.
SEVERE BURNS MAY RESULT.
CLOTHING IGNITION MAY RESULT.**



Glass and other surfaces are hot during operation and cool down.

- Keep children away.
- CAREFULLY SUPERVISE children in same room as appliance.
- Alert children and adults to hazards of high temperatures.
- Do NOT operate with protective barriers open or removed.
- Keep clothing, furniture, draperies and other combustibles away.

This appliance has been supplied with an integral barrier to prevent direct contact with the fixed glass panel. Do NOT operate the appliance with the protective barrier removed.

Contact your dealer or Hearth & Home Technologies if the barrier is not present or help is needed to properly install one.



WARNING

Improper installation, adjustment, alteration, service or maintenance can cause injury or property damage. Refer to the owner's information manual provided with this appliance. For assistance or additional information consult a qualified installer, service agency or the gas supplier.



WARNING

Do NOT use this appliance if any part has been under water. Immediately call a qualified service technician to inspect the appliance and to replace any part of the control system and any gas control which has been under water.

B. Lighting Appliance

Intellifire Ignition

FOR YOUR SAFETY READ BEFORE LIGHTING

WARNING: If you do not follow these instructions exactly, a fire or explosion may result causing property damage, personal injury or loss of life.

- A.** This appliance is equipped with an intermittent pilot ignition (IPI) device which automatically lights the burner. Do not try to light the burner by hand.
- B. BEFORE LIGHTING,** smell all around the appliance area for gas. Be sure to smell next to the floor because some gas is heavier than air and will settle on the floor.
- WHAT TO DO IF YOU SMELL GAS**
- Do not try to light any appliance.
 - Do not touch any electric switch; do not use any phone in your building.
 - Immediately call your gas supplier from a neighbor's phone. Follow the gas supplier's instructions.
 - If you cannot reach your gas supplier, call the fire department.
- C.** Do not use this appliance if any part has been under water. Immediately call a qualified service technician to inspect the appliance and to replace any part of the control system and any gas control which has been under water.

WARNING:

DO NOT CONNECT 110 VAC TO THE CONTROL VALVE.

Improper installation, adjustment, alteration, service or maintenance can cause injury or property damage. Refer to the owner's information manual provided with this appliance.

This appliance needs fresh air for safe operation and must be installed so there are provisions for adequate combustion and ventilation air.

If not installed, operated, and maintained in accordance with the manufacturer's instructions, this product could expose you to substances in fuel or fuel combustion which are known to the State of California to cause cancer, birth defects, or other reproductive harm.

Keep burner and control compartment clean. See installation and operating instructions accompanying appliance.

For additional information on operating your Hearth & Home Technologies fireplace, please refer to www.fireplaces.com.

CAUTION:

Hot while in operation. Do not touch. Keep children, clothing, furniture, gasoline and other liquids having flammable vapors away.

Do not operate the appliance with panel(s) removed, cracked or broken. Replacement of the panel(s) should be done by a licensed or qualified service person.

NOT FOR USE WITH SOLID FUEL

For use with natural gas and propane. A conversion kit, as supplied by the manufacturer, shall be used to convert this appliance to the alternate fuel.

Also Certified for Installation in a Bedroom or a Bedsitting Room.

For assistance or additional information, consult a qualified installer, service agency or the gas supplier.

LIGHTING INSTRUCTIONS (IPI)

1. Turn off all electric power to the appliance.
2. This appliance is equipped with an ignition device which automatically lights the burner. Do not try to light the burner by hand.

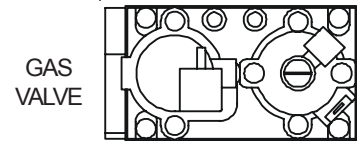

3. Wait five (5) minutes to clear out any gas. Then smell for gas, including near the floor. If you smell gas, STOP! Follow "B" in the Safety Information located on the left side of this label. If you don't smell gas, go to next step.
4. Turn on all electric power to the appliance.
5. To light the burner, flip the ON/OFF switch to the "ON" position. (The ON/OFF switch may include a wall switch if so equipped).
6. If the appliance will not operate, follow the instructions "To Turn Off Gas to Appliance" and call your service technician or gas supplier.

TO TURN OFF GAS TO APPLIANCE

1. Turn off all electric power to the appliance if service is to be performed.
2. Flip ON/OFF switch to the "OFF" position.

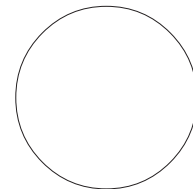

Final Inspection by _____

593-913D



C. After Appliance is Lit

Initial Break-in Procedure

When you light the appliance, you may notice that it produces heat which does have an associated odor or smell. If you feel this odor is excessive it may require the initial three to four hour continuous burn on high followed by a second burn up to 12 hours to fully drive off any odor from paint and lubricants used in the manufacturing process. Condensation of the glass is normal.



NOTE: The appliance should be run three to four hours on the initial start-up. Turn it off and let it cool completely. Remove and clean the glass. Replace the glass and run the appliance for an additional 12 hours. This will help to cure the products used in the paint and logs.

During this break-in period it is recommended that some windows in the house be opened for air circulation. This will help avoid setting off smoke detectors, and help eliminate any odors associated with the appliance's initial burning.

	 WARNING
	<p>Fire Risk. High Temperatures.</p> <p>Keep combustible household items away from appliance. Do NOT obstruct combustion and ventilation air.</p> <ul style="list-style-type: none"> • Do NOT place combustible items on top of or in front of appliance. • Keep furniture, draperies away from appliance.

CAUTION
<ul style="list-style-type: none"> • Prevent accidental appliance operation when not attended. • Unplug or remove batteries from remote control if absent or if appliance will not be used for an extended period of time. • Property damage possible from elevated temperatures.

CAUTION
<p>Smoke and odors released during initial operation.</p> <ul style="list-style-type: none"> • Open windows for air circulation. • Leave room during initial operation. • Smoke may set off smoke detectors. <p>Smoke and odors may be irritating to sensitive individuals.</p>

	 WARNING
	<p>Fire Hazard. Keep combustible materials, gasoline and other flammable vapors and liquids clear of appliance.</p> <ul style="list-style-type: none"> • Do NOT store flammable materials in the appliance's vicinity. • Do NOT use gasoline, lantern fuel, kerosene, charcoal lighter fluid or similar liquids in this appliance. • Combustible materials may ignite.

D. Frequently Asked Questions

ISSUE	SOLUTIONS
Condensation on the glass	This is a result of gas combustion and temperature variations. As the appliance warms, this condensation will disappear.
Blue flames	This is a result of normal operation and the flames will begin to yellow as the appliance is allowed to burn for 20 to 40 minutes.
Odor from appliance	When first operated, this appliance may release an odor for the first several hours. This is caused by the curing of the paint and the burning off of any oils remaining from manufacturing. Odor may also be released from finishing materials and adhesives used around the appliance.
Film on the glass	This is a normal result of the curing process of the paint and logs. Glass should be cleaned within 3 to 4 hours of initial burning to remove deposits left by oils from the manufacturing process. A non-abrasive cleaner such as gas fireplace glass cleaner may be necessary. See your dealer.
Metallic noise	Noise is caused by metal expanding and contracting as it heats up and cools down, similar to the sound produced by a furnace or heating duct. This noise does not affect the operation or longevity of the appliance.
Is it normal to see the pilot flame burn continually?	In an Intellifire ignition system it is normal to see the pilot flame, but it should turn off when ON/OFF is turned off. In a standing pilot system the pilot will always stay on.

14

Troubleshooting

With proper installation, operation, and maintenance your gas appliance will provide years of trouble-free service. If you do experience a problem, this troubleshooting guide will assist a qualified service person in the diagnosis of a problem and the corrective action to be taken. This troubleshooting guide can only be used by a qualified service technician.

A. Intellifire Ignition System

Symptom	Possible Causes	Corrective Actions
1. The ignitor/module makes noise, but no spark.	a. Incorrect wiring.	Verify "S" wire (white) for sensor and "I" wire (orange) for ignitor are connected to correct terminals on module and pilot assembly. Reversed wires at the module may cause system to make sparking noise, but spark may not be present at pilot hood.
	b. Loose connections or electrical shorts in the wiring.	Verify no loose connections or electrical shorts in wiring from module to pilot assembly. Rod closest to pilot hood should be ignitor. Verify connections underneath pilot assembly are tight; also verify connections are not grounding out to metal chassis, pilot burner, pilot enclosure, mesh screen if present, or any other metal object.
	c. Ignitor gap is too large.	Verify gap of igniter to pilot hood. The gap should be approximately .17 inch or 1/8 inch.
	d. Faulty module.	Turn ON/OFF rocker switch or wall switch to OFF position. Remove ignitor wire "I" from module. Place ON/OFF Rocker switch or wall switch in ON position. Hold ground wire about 3/16 inch away from "I" terminal on module. If there is no spark at "I" terminal module must be replaced. If there is a spark at "I" terminal, module is fine. Inspect pilot assembly for shorted sparker wire or cracked insulator around electrode.
2. Pilot won't light, there is no noise or spark.	a. Transformer installed correctly.	Verify that transformer is installed and plugged into module. Check voltage of transformer under load at spade connection on module with ON/OFF switch in ON position. Acceptable readings of a good transformer are between 3.2 and 2.8 volts AC.
	b. A shorted or loose connection in wiring configuration or wiring harness.	Remove and reinstall the wiring harness that plugs into module. Verify there is a tight fit. Verify pilot assembly wiring to module. Remove and verify continuity of each wire in wiring harness.
	c. Improper wall switch wiring.	Verify that 110/VAC power is "ON" to junction box.
	d. Module not grounded.	Verify black ground wire from module wire harness is grounded to metal chassis of appliance.
	e. Faulty module.	Turn ON/OFF rocker switch or wall switch to OFF position. Remove ignitor wire "I" from module. Place ON/OFF Rocker switch or wall switch in ON position. Hold ground wire about 3/16 inch away from "I" terminal on module. If there is no spark at "I" terminal module must be replaced. If there is a spark at "I" terminal, module is fine. Inspect pilot assembly for shorted sparker wire or cracked insulator around electrode.
3. Pilot lights but continues to spark, and main burner will not ignite. (If the pilot continues to spark after the pilot flame has been lit, flame rectification has not occurred.)	a. A shorted or loose connection in sensor rod.	Verify all connections to wiring diagram in manual. Verify connections underneath pilot assembly are tight. Verify connections are not grounding out to metal chassis, pilot burner, pilot enclosure or screen if present, or any other metal object.
	b. Poor flame rectification or contaminated sensor rod.	Verify that flame is engulfing sensor rod. If the pilot assembly does not have a ground strap, consider installing one to increase flame rectification. Verify correct pilot orifice is installed and inlet gas specifications. Flame carries rectification current, not the gas. If flame lifts from pilot hood, the circuit is broken. A wrong orifice or too high an inlet pressure can cause pilot flame to lift. The sensor rod may be contaminated. Clean sensor rod with emery cloth.
	c. Module is not grounded.	Verify that module is securely grounded to metal chassis of appliance. Verify that wire harness is firmly connected to module.

Intellifire Ignition System - (continued)

Symptom	Possible Causes	Corrective Actions
3. (Continued) Pilot lights but continues to spark, and main burner will not ignite. (If the pilot continues to spark after the pilot flame has been lit, flame rectification has not occurred.)	d. Damaged pilot assembly or dirty sensor rod.	Verify that ceramic insulator around the sensor rod is not cracked, damaged, or loose. Verify connection from sensor rod to white sensor wire. Clean sensor rod with emery cloth to remove any contaminants that may have accumulated on sensor rod. Verify continuity with a multimeter with ohms set at lowest range.
	e. Faulty module.	Turn ON/OFF rocker switch or wall switch to OFF position. Remove ignitor wire "I" from module. Place ON/OFF Rocker switch or wall switch in ON position. Hold ground wire about 3/16 inch away from "I" terminal on module. If there is no spark at "I" terminal module must be replaced. If there is a spark at "I" terminal, module is fine. Inspect pilot assembly for shorted sparker wire or cracked insulator around electrode.
4. Pilot sparks, but Pilot will not light.	a. Correct gas supply.	Verify that incoming gas line ball valve is "open". Verify that inlet pressure reading is within acceptable limits, inlet pressure must not exceed 14 in. W.C.
	b. Ignitor gap is too large.	Verify that spark gap from ignitor to pilot hood is .17 in. or 1/8 in.
	c. Module is not grounded.	Verify module is securely grounded to metal chassis of appliance.
	d. Module voltage output / Valve/Pilot solenoid ohms readings.	Verify battery voltage is at least 2.7 volts. Replace batteries if voltage is below 2.7.
5. Pilot will not stay lit after carefully following lighting instructions.	a. Pilot plate out of position.	Ensure pilot plate is in proper position (see Section 7).

15

Maintaining and Servicing Appliance

Although the frequency of appliance servicing and maintenance will depend on use and the type of installation, a qualified service technician should perform an appliance check-up at the beginning of each heating season.

WARNING

Risk of injury or property damage.

Before servicing:

- Turn off gas.
- Turn off electricity to appliance.
- Disable remote control, if one is present.
- Ensure appliance is completely cooled.

After servicing:

- Replace any screen or barrier that was removed.
- Reseal and reinstall any venting removed for servicing.

WARNING

Annual inspection by qualified technician recommended.

Check:

- Condition of doors, surrounds and fronts.
- Condition of glass, glass assembly and glass seal.
- Obstructions of combustion and ventilation air.
- Condition of logs.
- Condition of firebox.
- Burner ignition and operation.
- Burner air shutter adjustment
- Gas connections and fittings.
- Obstructions of termination cap.

Clean:

- Glass
- Air passageways, grilles, control compartment
- Burner, burner ports

Risk of:

- Fire
- Delayed ignition or explosion
- Exposure to combustion fumes
- Odors



CAUTION



Handle glass assembly with care.

NOTE: Clean glass after initial 3-4 hours operation. **Longer operation without cleaning glass may cause a permanent white film on glass.**

When cleaning glass door:

- Avoid striking, scratching or slamming glass.
 - Do NOT use abrasive cleaners.
 - Use a hard water deposit glass cleaner on white film.
 - Do NOT clean glass when hot.
 - Turn off appliance after 3-4 hours of operation and ALLOW TO COOL.
 - Remove and clean glass assembly.
 - Replace glass assembly and operate appliance for additional 12 hours.
- Refer to maintenance instructions.

WARNING



Inspect external vent cap regularly.

- Ensure no debris blocks cap.



- Combustible materials blocking cap may ignite.
- Restricted air flow affects burner operation.

Inspect	Maintenance Tasks
Doors, Surrounds and Fronts	1. Assess condition of screen and replace as necessary. Recommend addition of screen if one is not present.
	2. Inspect for scratches, dents or other damage and repair as necessary.
	3. Verify no obstructions to airflow through the louvers.
	4. Verify maintenance of proper clearance to combustible household objects.
Gasket Seal, Glass Assembly and Glass	1. Inspect gasket seal and its condition.
	2. Inspect glass panels for scratches and nicks that can lead to breakage when exposed to heat.
	3. Confirm there is no damage to glass or glass frame. Replace as necessary.
	4. Verify that latches engage properly, clip studs are not stripped, and glass attachment components are intact and operating properly. Replace as necessary.
	5. Clean glass. Replace glass assembly if severely coated with silicate deposits that cannot be removed.
Valve Compartment and Firebox Top	1. Vacuum and wipe out dust, cobwebs, debris or pet hair. Use caution when cleaning these areas. Screw tips that have penetrated the sheet metal are sharp and should be avoided.
	2. Remove any foreign objects.
	3. Verify unobstructed air circulation.
Logs	1. Inspect for broken, damaged, or missing logs. Replace as necessary.
	2. Verify correct log placement and no flame impingement causing sooting. Correct as necessary.
Firebox	1. Inspect for paint condition, warpage, corrosion or perforation. Sand and repaint as necessary.
	2. Replace appliance if firebox has been perforated.
Burner Ignition and Operation	1. Verify burner is properly secured and aligned with pilot or igniter.
	2. Clean off burner top, inspect for plugged ports, corrosion or deterioration. Replace burner if necessary.
	3. Replace ember materials with new dime-size and shape pieces. Do not block ports or obstruct lighting paths.
	4. Check for smooth lighting and ignition carryover to all ports. Verify there is no ignition delay.
	5. Inspect for lifting or other flame problems.
	6. Verify air shutter is clear of dust and debris.
	7. Inspect orifice for soot, dirt or corrosion.
	8. Verify manifold and inlet pressures. Adjust regulator as required.
	9. Inspect pilot flame strength. Clean or replace orifice as necessary.
	10. Inspect thermocouple/thermopile or IPI sensor rod for soot, corrosion and deterioration. Clean with emery cloth or replace as required.
	11. Verify millivolt output. Replace as necessary.
Venting	1. Inspect venting for blockage or obstruction such as bird nests, leaves, etc.
	2. Confirm that termination cap remains clear and unobstructed by plants, etc.
	3. Verify that termination cap clearance to subsequent construction (building additions, decks, fences or sheds) has been maintained.
	4. Inspect for corrosion or separation.
	5. Verify weather stripping, sealing and flashing remains intact.
	6. Inspect draft shield to verify it is not bent, damaged or missing.
Remote controls	1. Verify operation of remote.
	2. Replace batteries in remote transmitters and battery-powered receivers.
	3. Verify batteries have been removed from battery back-up IPI systems to prevent premature battery failure or leaking.

16

Reference Materials

A. Appliance Dimension Diagram

Dimensions are actual appliance dimensions. Use for reference only. For framing dimensions and clearances refer to **Section 3**.

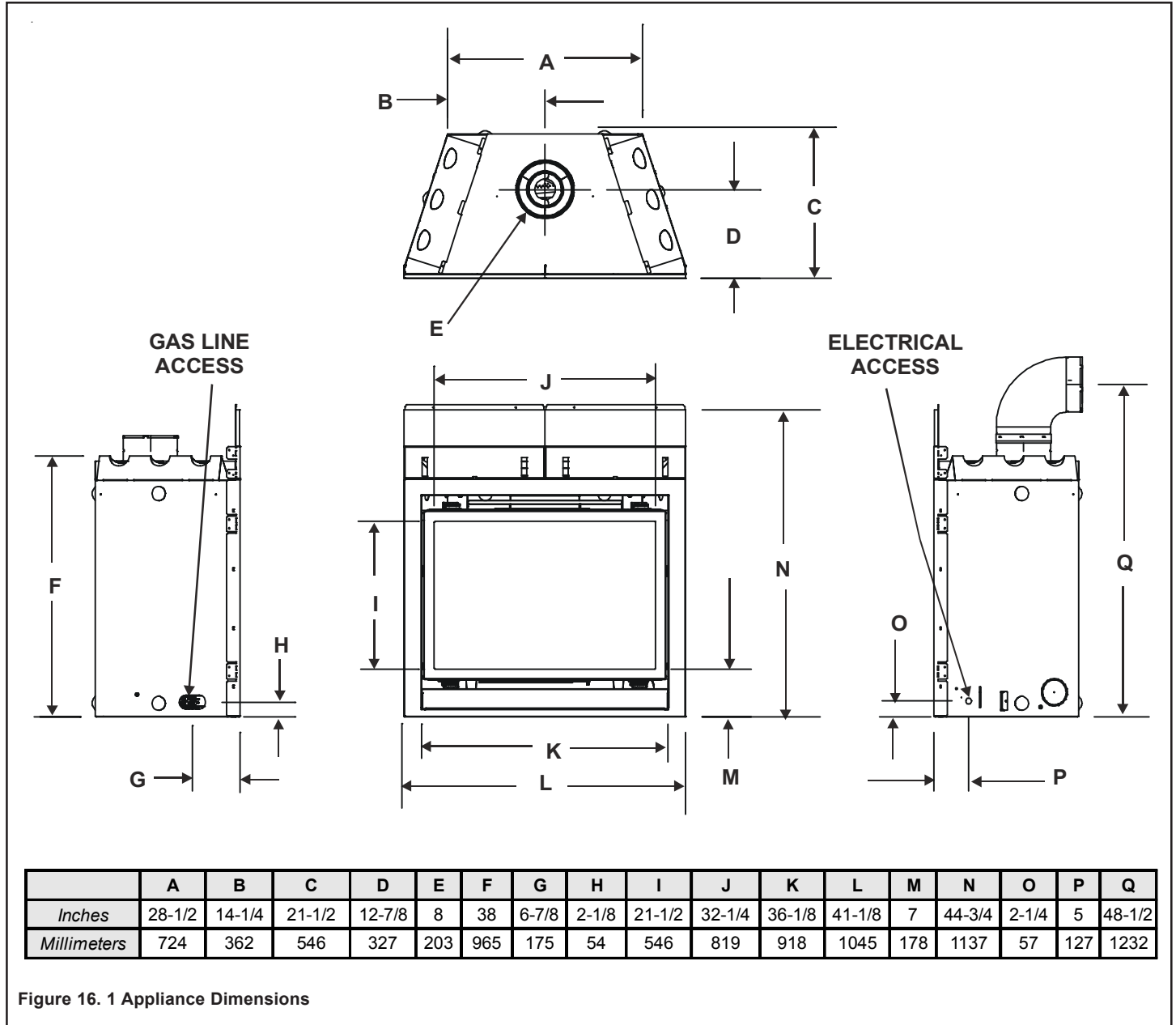
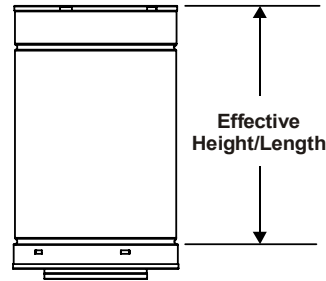

Figure 16. 1 Appliance Dimensions

B. Vent Components Diagrams



DVP Pipe (see chart)

Pipe	Length/Inches
DVP4	4
DVP6	6
DVP12	12
DVP24	24
DVP36	36
DVP48	48
DVP6A	3 to 6
DVP12A	3 to 12
DVP12MI	3 to 12
DVP24MI	3 to 24

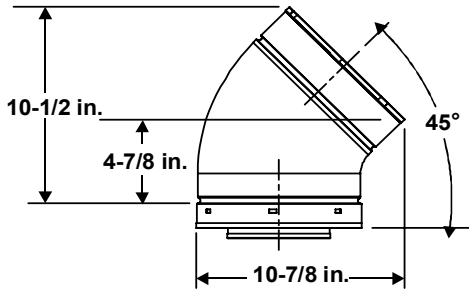

DVP45 (45° Elbow)

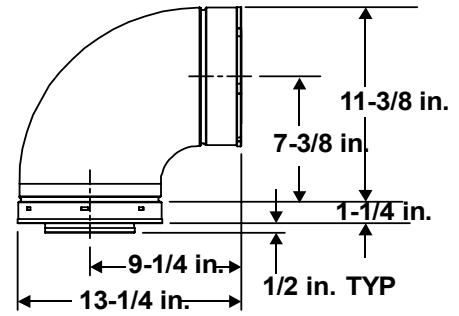

DVP90, DVP90ST (90° Elbow)

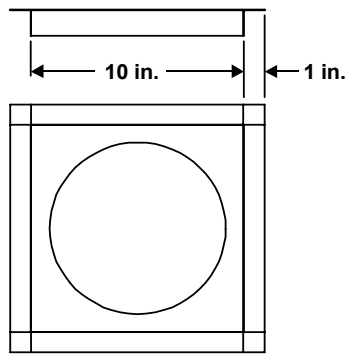

DVP-FS (Ceiling Firestop)

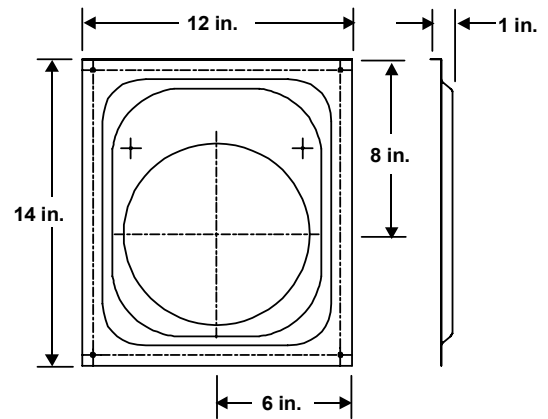

DVP-WS (Wall Shield Firestop)

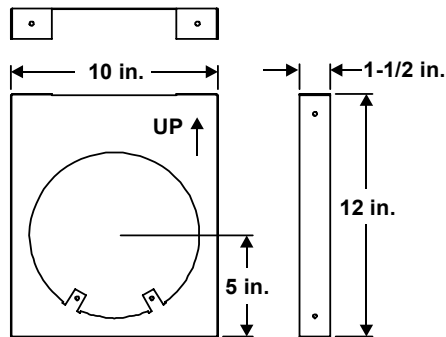

DVP-HVS (Vent Support)

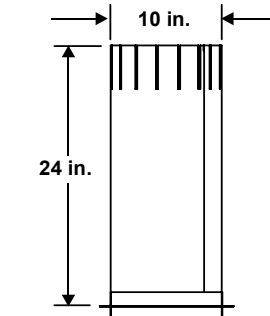

DVP-AS (Attic Shield)

Figure 16.2 DVP vent components

B. Vent Components Diagrams (continued)

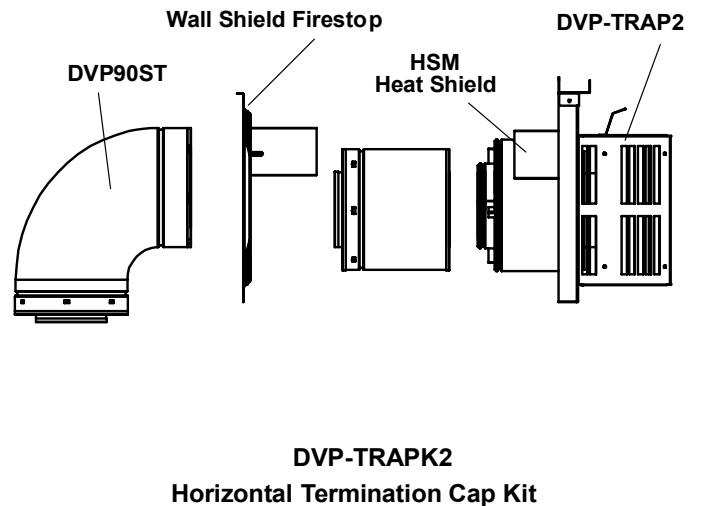
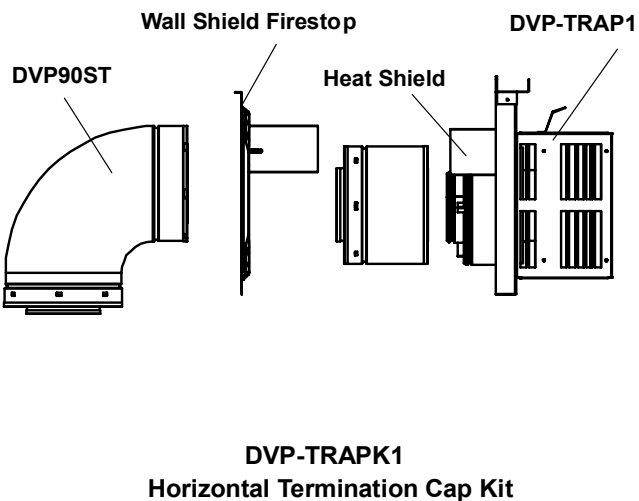
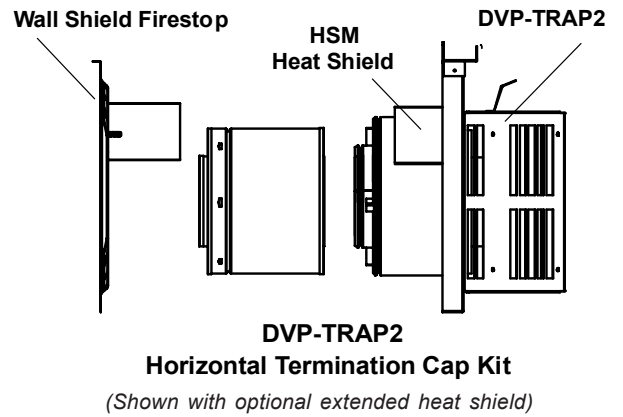
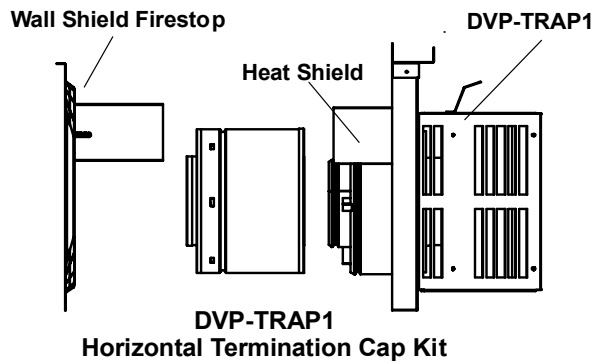
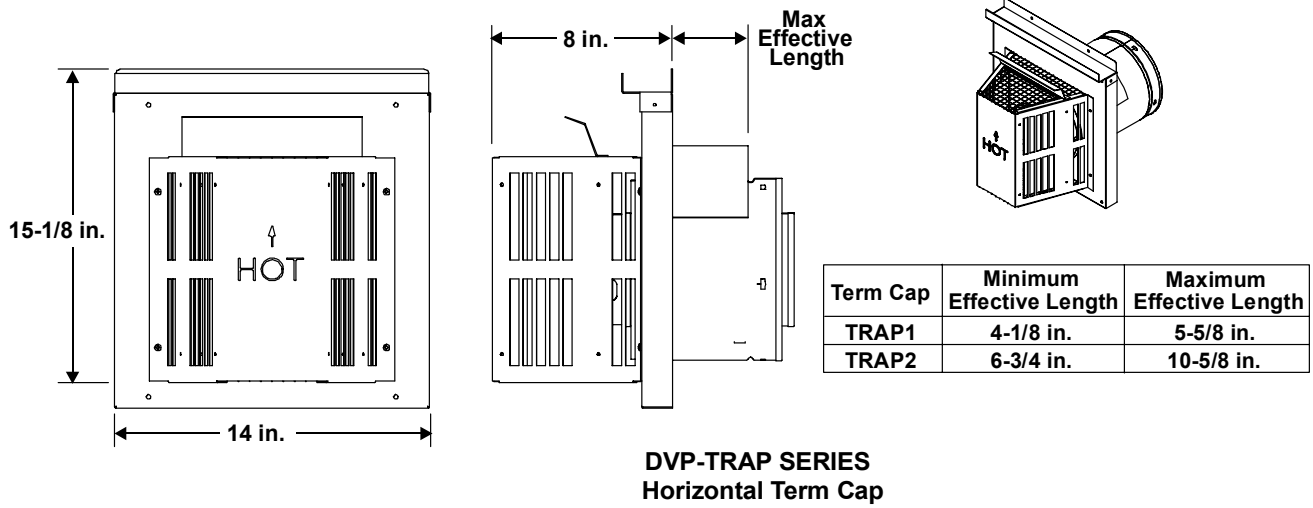
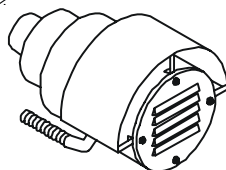
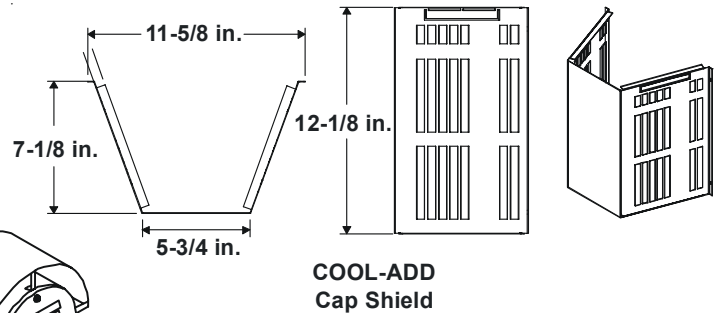
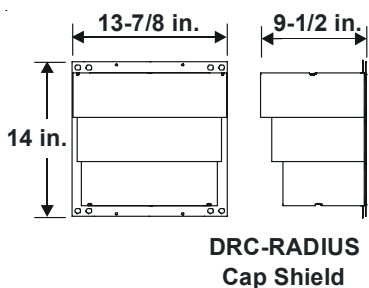
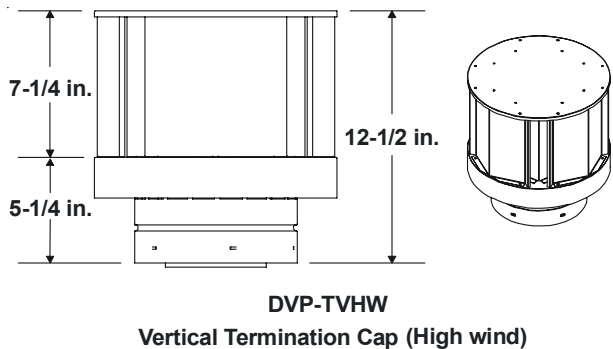
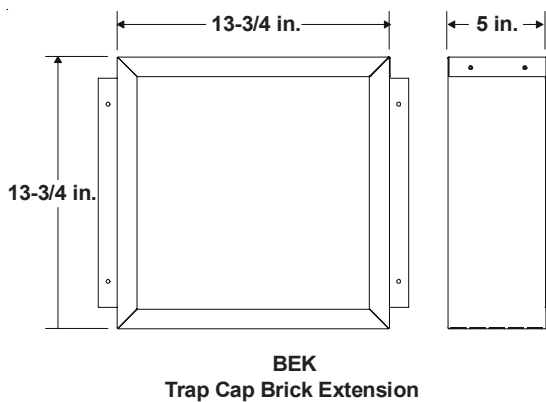
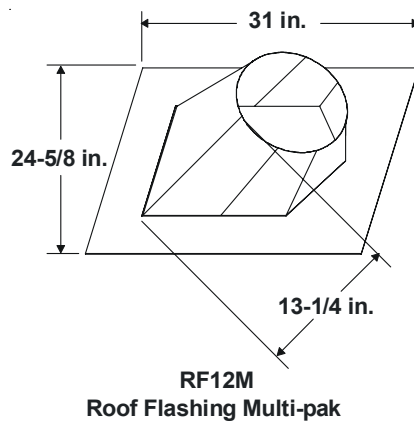
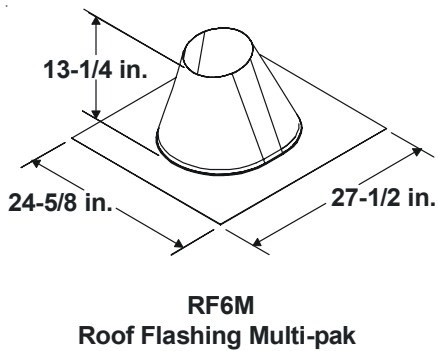
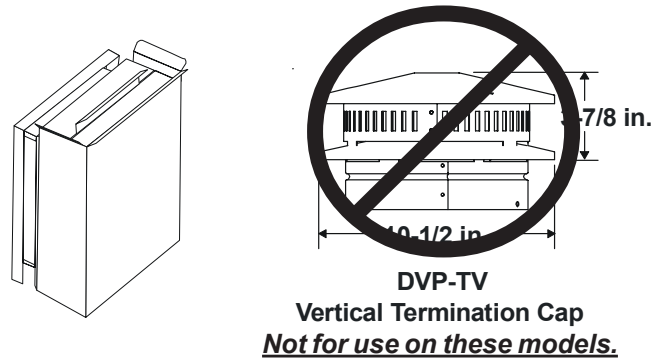
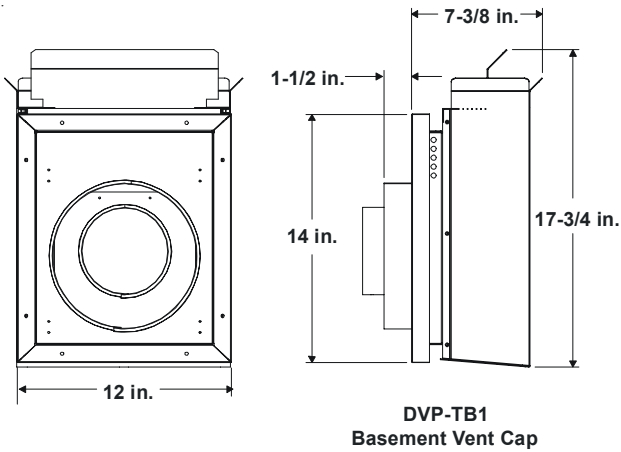

Figure 16.3 DVP vent components

B. Vent Components Diagrams (continued)



PVK-80
Power Vent

(For use on
Intellifire
appliances only)

Figure 16.4 DVP vent components

D. Limited Lifetime Warranty

LIMITED LIFETIME WARRANTY HEAT & GLO GAS APPLIANCE PRODUCTS



BASIC ONE-YEAR WARRANTY. HEAT & GLO, a brand of HEARTH & HOME TECHNOLOGIES INC., located at 20802 Kensington Boulevard, Lakeville, MN 55044, ("HEAT & GLO") warrants to the original owner that your new HEAT & GLO Gas Appliance (the "Product") will be free from defects in materials and workmanship for a period of one year from the date of installation. During the first year, HEAT & GLO will replace or repair, at its discretion, any defective components at its sole cost and expense, including payment of all reasonable labor costs incurred in replacing or repairing such components. This basic warranty is subject to the conditions, exclusions and limitations described below.

EXTENDED LIFETIME COVERAGE. HEAT & GLO warrants that the firebox, heat exchanger log(s), and burner will not be defective in material or workmanship during the period the Product is owned by the original owner, subject to the following conditions, exclusions and limitations described below.

CONDITIONS, EXCLUSIONS AND LIMITATIONS:

1. This warranty applies to the original owner only and is not transferable.
2. This warranty applies only to Products installed in the United States of America or Canada.
3. This warranty is limited to the replacement or repair of defective components or workmanship and HEAT & GLO may fully discharge all obligations under this warranty by repairing or replacing, at its discretion, the defective components. The maximum amount recoverable under this warranty is limited to the purchase price of the Product and, if HEAT & GLO is unable to provide replacement or repair in an expedient and cost-effective manner, HEAT & GLO may discharge all obligations under this warranty by refunding the purchase price of the Product. **IN NO EVENT SHALL HEAT & GLO BE LIABLE FOR ANY INCIDENTAL OR CONSEQUENTIAL DAMAGES CAUSED BY DEFECTS IN THE PRODUCT.**
4. Any labor and related repair charges relating to the costs and expenses of replacing or repairing defective components under the Limited Lifetime Warranty are not covered by this warranty, except as provided for under the Basic One-Year Warranty.
5. Components and parts made by other manufacturers, whether sold with the Product or added thereafter, are NOT covered by this warranty unless expressly authorized and approved by HEAT & GLO in writing.
6. Any damages caused by environmental conditions, inadequate ventilation or drafting caused by tight sealing construction of the structure, air handling devices such as exhaust fans or forced air furnaces, or other such causes are not covered by this warranty.
7. This warranty will be void if:
 - a) The Product is not installed, operated and maintained in compliance with local building codes and with the instructions in the Installer's Guide, Owner's Guide and Listing Agent Identification Label furnished with the Product.
 - b) Any parts or components made by other manufacturers are added or used in the Product, unless expressly authorized and approved by HEAT & GLO in writing.
 - c) Any service work is performed on the Product by anyone other than an authorized HEAT & GLO representative.
 - d) The Product is damaged due to shipping, improper handling, accident, abuse or misuse.
 - e) Fuels other than those specified in the Installer's Guide and Owner's Guide are used.
 - f) Modification was made to the Product which was not expressly authorized and approved by HEAT & GLO in writing.

EXCEPT TO THE EXTENT PROVIDED BY LAW, HEAT & GLO MAKES NO EXPRESS WARRANTIES OTHER THAN THE WARRANTY SPECIFIED HEREIN. THE DURATION OF ANY IMPLIED WARRANTY IS LIMITED TO THE DURATION OF THE WARRANTY SPECIFIED ABOVE.

Some states do not allow limitations on how long an implied warranty lasts, or do not allow exclusion or limitation of incidental or consequential damages, so those limitations may not apply to you. This warranty gives you specific legal rights, and you may also have other rights which vary from State to State.

If warranty service is needed you should contact your installing dealer and if the installing dealer is unable to provide necessary parts or components, contact the nearest authorized HEAT & GLO dealer or supplier

NOTES TO CUSTOMER:

1. In order to insure proper installation, operation and maintenance HEAT & GLO strongly recommends annual servicing by an authorized HEAT & GLO dealer.
2. Please complete this information and retain this warranty in a safe place for future reference: Installation Date: _____
Model #: _____ Serial #: _____ Installing Contractor: _____
3. HEAT & GLO reserves the right to make changes at any time, without notice, in design, material, specifications and prices of the Product. HEAT & GLO also reserves the right to discontinue styles and products.

