

INSTALLATION AND OPERATING INSTRUCTIONS

INTRODUCTION

This HEARTH & HOME TECHNOLOGIES remote control system was developed to provide safe, reliable, and user-friendly remote control system for gas heating appliance. The system can be operated thermostatically or manually from the transmitter. The system operates on radio frequencies (RF) within a 20 foot range using non-directional signals. The system operates on one of 1,048,576 security codes that are programmed into the transmitter at the factory. The remote receiver's code must be matched to that of the transmitter prior to initial use.

Review **COMMUNICATION SAFETY SECTION** under **TRANSMITTER** section and **THERMO SAFETY SECTION** under **REMOTE RECEIVER** section. These signal/temperature safety features shut down the fireplace system when a potentially unsafe condition exists.

TRANSMITTER

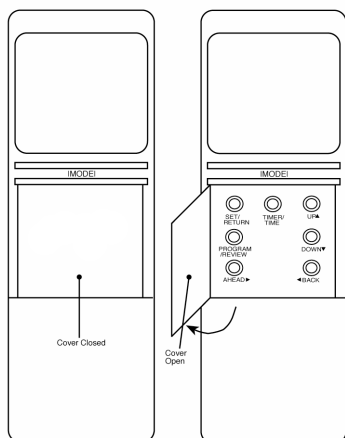

The transmitter operates on 4 AAA-size 1.5V batteries. It is recommended that ALKALINE batteries always be used for longer battery life and maximum operational performance. **IMPORTANT:** New or fully charged batteries are essential for proper operation of the multi-function transmitter.

Insert 4 AAA-size 1.5 V batteries into the battery compartment on the back of the transmitter, positioning the (+) and (-) ends of the batteries as indicated on the casing. When the batteries are inserted, the screen at right (with similar numbers) will display.

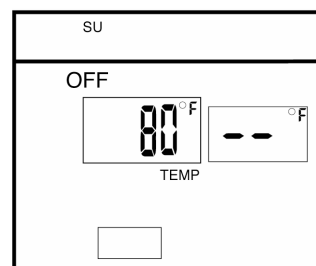

NOTE: If a LOW battery icon appears on the screen, check the position of the batteries. A reversed battery will activate the LOW battery icon.

NOTE: Due to the sensitive temperature-monitoring components in the transmitter, it may be necessary to allow the transmitter to stabilize to room temperature before accurate room temperatures are displayed on the screen. If the transmitter is activated from a severe cold condition, it can take up to fifteen minutes for accurate temperature readings to appear.

LCD DISPLAY SCREEN

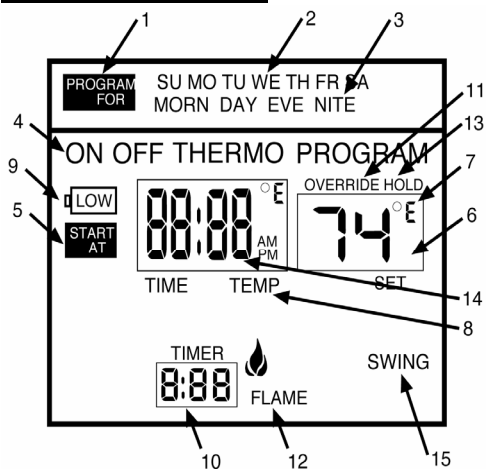

1. PROGRAM FOR: Flashes when programming days of week and periods of the day. When in normal state, only current DAY displays. When programming or in PROGRAM mode, both day and week will appear.
2. DAY –Flashes when current day or day of week is being programmed.
3. PERIOD – Flashes when current period of day or period of week is being programmed.
4. MODE – Indicates operation MODE of system.
 - ON indicates the system is on, either manually or thermostatically.
 - OFF indicates the entire system is turned off
 - THERMO indicates the system will automatically cycle ON/OFF, depending on programmed SET temperature.
 - PROGRAM – indicates the system is operating with PROGRAMMED settings.
5. START AT – Flashes when programming the time to turn system ON.
6. SET – Indicates desired SET room temperature, when in THERMO or PROGRAM mode.
7. °F / °C – Factory programmed in °F (°C indicates degrees in Celsius)
8. TIME/TEMP – Displays the CURRENT room temperature. In same frame, the current time will display in AM or PM. You must depress the TIME/TIMER button to display current time.

9. LOW – Battery power is low. Replace batteries within 2 weeks.
10. TIMER – When displayed, indicates countdown timer in operation
11. OVERRIDE – Displays when “programmed” SET temperature is overridden.
12. FLAME – Single flame symbol indicates burner/valve is operational.
13. HOLD – Displays when “programmed” SET temperature is overridden and will hold that temperature until cancelled.
14. CP – Displays when CHILD PROOF “LOCK OUT” is engaged. Pressing the UP and TIMER buttons together, engages CP.
15. SWING- Displays in SET frame when setting TEMPERATURE DIFFERENTIAL.

FUNCTIONS

To operate the system, press the MODE button on the transmitter to select the operational MODE desired.

- ON indicates the system is on, either manually, timed or thermostatically
- THERMO indicates the system will automatically cycle ON/OFF, depending on programmed set temperature.
- OFF indicates the entire system is turned off.
- PROGRAM indicates the system will automatically cycle ON/OFF in the programmed mode depending on the 7 day/4 period program that is in memory.

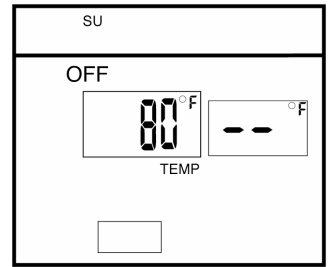

BUTTON SETTINGS

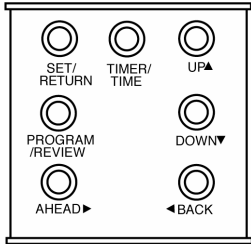

Flip open the plastic cover on the front of the transmitter to expose the "SET" buttons. The flip cover protects the SET buttons from being changed accidentally. Close the cover after completing the following settings/programming.

Flashing numbers on the display indicate the system is awaiting user input, such as using the UP and DOWN buttons to program a new setting. If no change is made to flashing digits within 15 seconds, the system will complete the procedure last programmed and reset the display to its normal state.

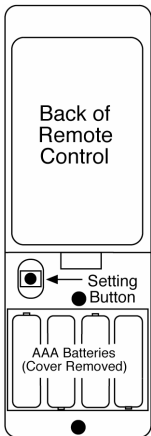

INITIAL SET-UP PROGRAMMING OF TRANSMITTER

Follow the procedures below, upon FIRST USE of transmitter, setting the following program options:

- TEMPERATURE SETTING – °F (Fahrenheit) or °C (Celsius)
- CURRENT DAY OF WEEK – SU, MO, TU, WE, TH, FR, SA
- CURRENT TIME OF DAY – Hours and minutes

To program settings, first remove the battery cover on the back of the transmitter. If you have not already installed the 4-AAA batteries, this would be a good time to do so. Note the small push button at the upper left side of the battery compartment. This is the button used to perform the initial transmitter programming.

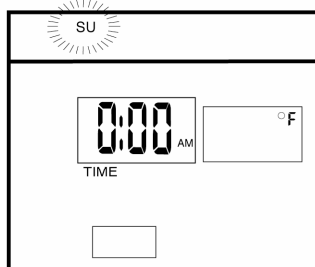
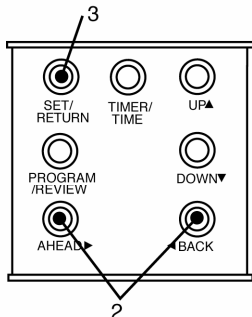
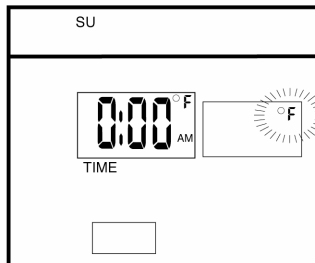
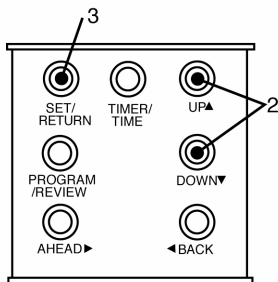

CHANGING THE TEMPERATURE SCALE

1. Press setting button on back of transmitter ONCE and the degree F symbol will begin flashing on the LCD screen. You may replace the battery cover at this time.
2. To change degree F to degree C, press the UP or DOWN button on the front of the transmitter.
3. After setting/confirming the preferred temperature SCALE, press the SET/RETURN button on the front of the transmitter.

NOTE: You will need to press the SET/RETURN button, confirming degree F, if you want the temperature readings to be in degree F.

SETTING THE CURRENT DAY OF THE WEEK

1. Following Step 3 above, the symbol SU will begin flashing on the LCD screen.
2. To change to the CURRENT day of the week, press the AHEAD or BACK button on the front of the transmitter.
3. After setting/confirming the current Day of the week, press the SET/RETURN button on the front of the transmitter.

NOTE: You will need to press the SET/RETURN button, confirming SU, if that is the current day.

SETTING THE CURRENT HOUR AND MINUTES

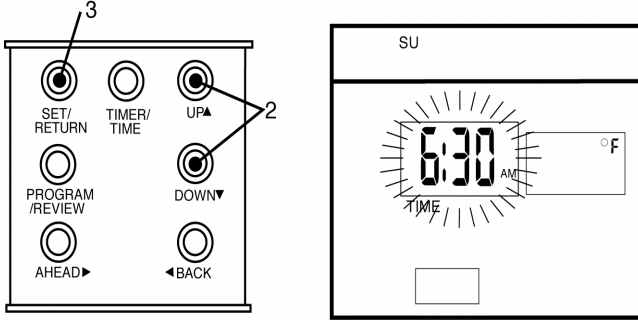

1. Following Step 3 above, the HOUR digits will begin flashing in the TIME frame on the LCD screen.
2. To set the current HOUR, press the UP or DOWN button setting the HOUR for the corresponding AM/PM time period.
3. After setting the current HOUR, press the SET/RETURN button on the front of the transmitter, and the MINUTE digits will begin flashing on the LCD screen
4. To set the current MINUTES, press the UP or DOWN button setting the correct MINUTES.
5. After setting the HOURS and MINUTES, press the SET/RETURN button on the front of the transmitter.

The initial set-up/programming of the transmitter is now complete. Be sure the slide-on battery cover is reinstalled and proceed to the next step. The LCD screen will now display in its normal state.

**PROGRAM OPERATION OF REMOTE CONTROL
BUILT-IN PROGRAM**

DAY	PERIOD	TIME/TEMP
All 7 Days	MORN	6:00 AM 70 °
Factory-Programmed	DAY	8:30 AM 60 °
	EVE	3:00 PM 70 °
	NIGHT	11:00 PM 63 °

BUILT-IN PROGRAM

The transmitter has a factory program built in. Each day has been broken into four periods and each period has its own starting time and temperature. A chart of the built-in programs is at the left.

You may change any of the factory settings by following the procedures below. Should you wish to return to the factory program, follow the procedures under PROGRAM REVIEW or PROGRAM CANCELLATION depending on which process you select.

PROGRAMMING DAYS/PERIOD OF DAY/SET TEMPERATURES

CUSTOM PROGRAM (By User)

DAY	PERIOD				TIME/TEMP
	MORN	DAY	EVE	NITE	
SU					
MO					
TU					
WE					
TH					
FR					
SAT					

PROGRAMMING THE TRANSMITTER

The user may change the built-in time and temperature programs to suit their personal schedule. Each day is divided into four periods: MORNING, DAY, EVENING, AND NIGHT. A blank programming chart is provided to the left to record your customized time and temperature settings.

If desired, you may change a single day or all seven days that have the built-in factory program. To change one or all seven days, complete the following steps:

1. Press the PROGRAM/REVIEW button for 4 seconds. The shaded boxes on the LCD screen with the words PROGRAM FOR and START AT will begin to flash.

The current DAY, PERIOD, TIME and SET temperature of the BUILT-IN FACTORY PROGRAM will also be displayed.

NOTE: If the above settings were not previously completed during the initial SET-UP and PROGRAMMING procedure, then the LCD screen will display SU, MORN, TIME and SET temperature digits. You must go back and perform the initial set-up procedure or the remote will not operate properly in the PROGRAM mode. SEE PAGE 2.

2. To program the DAY and PERIOD OF DAY, press the AHEAD or BACK buttons to display the DAY and PERIOD you wish to program.
3. When the DAY and PERIOD being programmed displays, then press the PROGRAM/REVIEW button and the TIME will flash on the LCD screen.

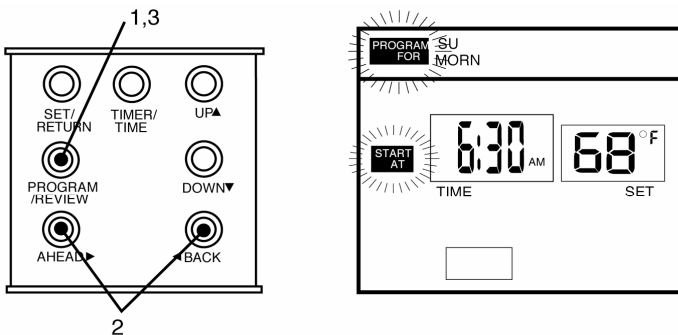

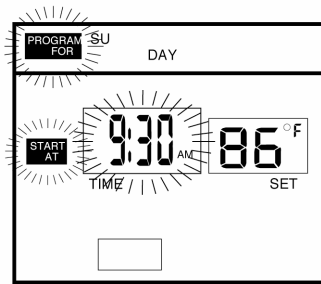
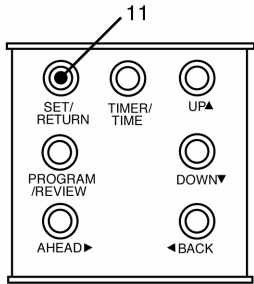
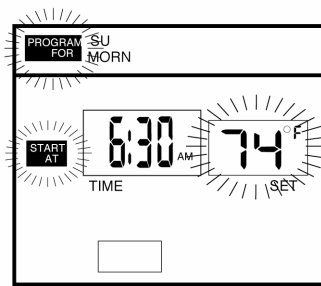
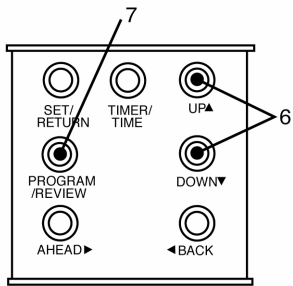
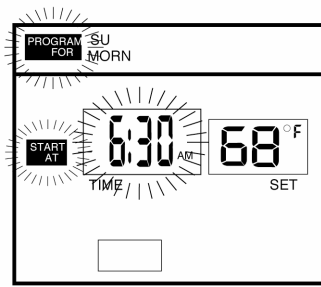
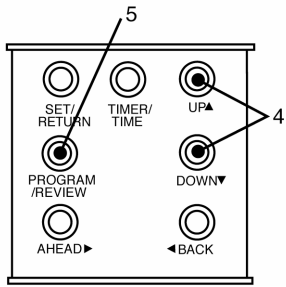

4. To program the START TIME, press the UP or DOWN button. Programmed start time settings are in 15 minute segments. The new set time will display on the LCD screen.
5. When the desired START TIME displays, press the PROGRAM/REVIEW button and the SET TEMPERATURE will flash on the LCD screen.
6. To program the SET TEMPERATURE, press the UP or DOWN button.
7. When the desired SET TEMPERATURE displays, then press the PROGRAM/REVIEW button.
8. After pressing the PROGRAM/REVIEW button in step 7, the next PERIOD of the same or next day will display on the LCD screen.
9. To program the next PERIOD follow steps 3 through 7.
10. Continue to follow steps 3 through 7 until all 7 days and the 4 time periods in each day are programmed.
11. Once ALL the programming has been completed, then press the SET/RETURN button. The programming data that has been entered will now over-ride the factory built-in program and operate your remote control system.

PROGRAMMING NOTE:

Once you are in the programming process and want to advance the programming procedure, you may bypass some of the DAYS or PERIODS OF DAY, by pushing the AHEAD or BACK buttons. This allows you to eliminate the need to enter the TIME and TEMPERATURE for each DAY/PERIOD, and speeds up the programming process by skipping some of the "software prompts". Once the LCD screen displays a DAY/PERIOD you want to reprogram, press the PROGRAM/REVIEW button and follow the programming steps outlined above.

PROGRAM REVIEW

If you want to review the settings for either the FACTORY program and/or your CUSTOMIZED program, you may do so by pressing the PROGRAM/REVIEW button for one second. To review other settings, press the PROGRAM/REVIEW button allowing one second between each press of the PROGRAM/REVIEW button. If you press the PROGRAM/REVIEW button for 4 seconds, then you go into the programming process. Press the SET/RETURN button should you hold the PROGRAM/REVIEW button too long.

PROGRAM CANCELLATION

Should you want to cancel the CUSTOMIZED program that you have entered and return to the FACTORY program, you may do so. To cancel a CUSTOMIZED program:

1. Press the SET/RETURN button to make sure the LCD screen is in normal state.
2. Then press and hold the PROGRAM/REVIEW button and, at the same time, press the SET/RETURN button for a period of 10 seconds.
3. The customized programs will be cancelled when the display icons/numbers flash with some icons disappearing. The LCD screen will begin flashing PROGRAM FOR, START AT, and the digits in the TIME and SET frames will begin flashing. This confirms CUSTOMIZED programs have been cancelled.
4. Push the SET/RETURN button to return LCD screen to normal state or wait 10 seconds and LCD screen will return to normal state automatically.

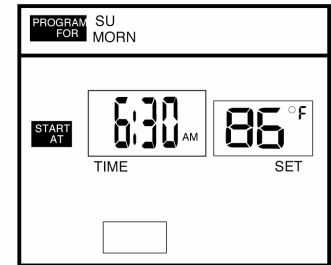
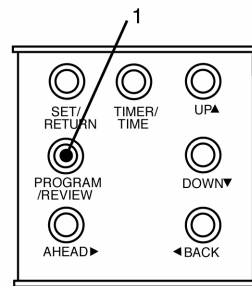

ADDITIONAL PROGRAMMING OPTIONS SWING

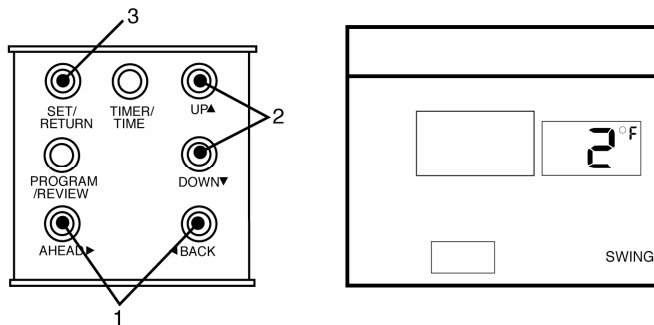

1 = +/- 1 ° F (.5 ° C), 2 = +/- 2 ° F (1 ° C), 3 = +/- 3 ° F (1.6 ° C).

1. To change the temperature “SWING” setting (1-3), press the AHEAD + BACK buttons simultaneously to display the current “SWING” setting in the SET TEMP frame. The word SWING will display on the LCD screen.
1. Press the UP or DOWN button to change the temperature differential or “SWING” (1-3). See above for 1-3 “SWING” temperature values.
2. To store the “swing number”, press the SET/RETURN button or allow 15 seconds to lapse, and the new “swing number” will be automatically programmed.

MANUAL CHECK OF “SWING” OR TEMPERATURE DIFFERENTIAL

The operation of the factory set “THERMO SWING” can be checked by adjusting the SET TEMP 2 ° F above or below the room temperature. This will cause the system to turn ON or OFF. Normally the system will only respond to temperature changes every two minutes. Manually changing the SET temperature will activate the system in less than 10 seconds. If the “SWING” is changed, then a new room temperature differential will respond. Factory setting of SWING temperature is 2 ° F.

When the gas fireplace system is activated, a FLAME icon will display on the LCD screen indicating a signal has been sent from the TRANSMITTER.

OPERATING INSTRUCTIONS

THERMO OPERATION – (System operates thermostatically based on SET TEMP setting, ONLY)

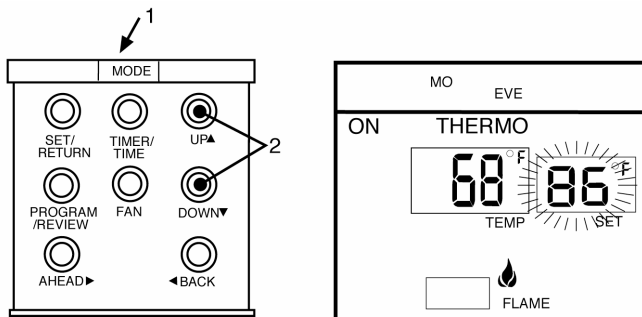

SETTING DESIRED ROOM TEMPERATURE

This remote control system can be thermostatically controlled when the transmitter is in the THERMO mode (THERMO must be displayed on the screen).

1. To set the DESIRED room temperature, press the MODE button to place the transmitter into THERMO mode. THERMO ON or OFF will display.
2. Then press the UP or DOWN button to select the DESIRED room temperature. The highest SET temperature is 99 ° F (32 ° C). The lowest SET temperature is 45 ° F (6 ° C).
3. The TRANSMITTER will “sense” the room temperature every two minutes automatically turning the fireplace ON or OFF thermostatically.

OPERATIONAL NOTE: TO CONSERVE BATTERY POWER, CHANGES IN TEMPERATURE ARE ONLY RECORDED EVERY TWO MINUTES. Additionally, to prevent repeated thermo-cycling of the gas appliance, the sensing unit in the transmitter will only activate the remote receiver when the temperature change exceeds 2 ° F (1 ° C) above or below the SET (desired) temperature. However, if the “SWING” setting has been changed from the factory setting (2 ° F /1° C), then thermo-cycling will activate at the new setting of the “SWING” number.

MANUAL CHECK OF THERMO OPERATION

The operation of the Thermo setting can be checked on demand by adjusting the SET temperature 2⁰ F above or below the room temperature, which will cause the system to turn ON or OFF, respectively. Normally, however, the system will only respond to temperature changes every two minutes. NOTE: if "SWING" number has been changed, then activation will occur at the new "SWING" setting.

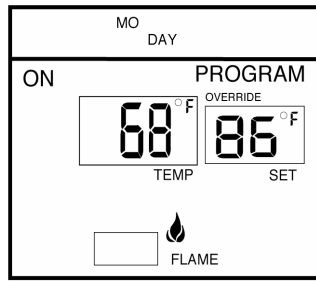
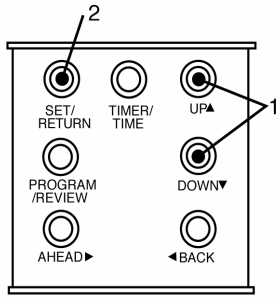

TEMPERATURE OVERRIDE – (Operates only in PROGRAM mode)

The user may change the current SET temperature without changing the programs stored in the transmitter's memory. The OVERRIDE feature will be automatically cancelled at the start of the next PROGRAM PERIOD.

1. To change current SET TEMP, press the UP or DOWN key. (Setting will be cancelled automatically when next program period begins.) The word OVERRIDE will appear over the SET frame on the LCD.
2. To cancel temperature OVERRIDE, press SET/RETURN button.

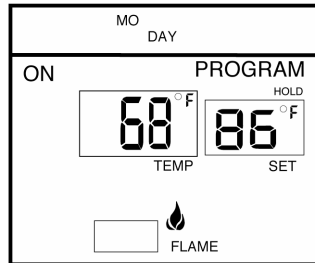
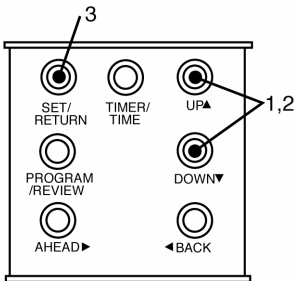

TEMPERATURE HOLD – (Operates only in PROGRAM mode.)

The user may override the SET temperature during any period, adjusting the SET temperature to a CONSTANT new SET/HOLD temperature.

1. Press the UP or DOWN button to change the SET temperature to the level desired. The word OVERRIDE will appear in SET frame on the LCD.
2. To HOLD the new temperature at a CONSTANT setting, push the UP and DOWN buttons TOGETHER to activate the HOLD function. The word HOLD will appear over the SET frame and the word OVERRIDE will disappear.
3. To cancel OVERRIDE or HOLD, press the SET/RETURN button.

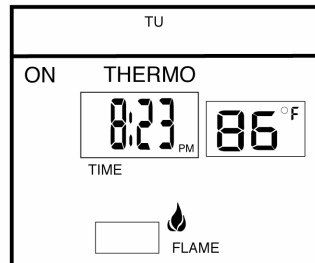
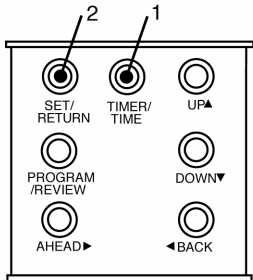

TIME OF DAY DISPLAY

1. To check the current TIME of day, press the TIME/TIMER button on the transmitter for less than 1 second. The current TIME of day will appear in the TIME/TEMP frame replacing the temperature reading.
2. The TEMPERATURE will reappear in 15 seconds, or you can press the SET/RETURN button to cancel the time display.

SETTING THE COUNTDOWN TIMER

This remote control can operate with a built-in, countdown timer when the transmitter is in the ON or THERMO mode (THERMO or ON must be displayed on the LCD screen). DO NOT operate in PROGRAM MODE as times are pre-programmed into the transmitter.

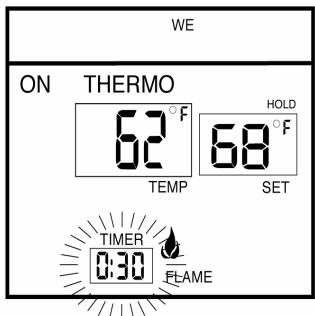
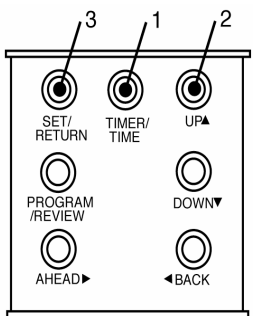

1. Press the TIME/TIMER button on the transmitter for more than 2 seconds. The word TIMER and 0:15 flash on the LCD screen
2. Press the UP or DOWN button on the transmitter to begin advancing through each of the countdown time options. Available countdown times are 15 min., 30 min, 45 min, 1 hr, 1 hr 30 min, 2 hr, 2 hr 30 min, and each additional half hour up to nine hours. To set the TIMER < press the SET/RETURN button on the transmitter. If the system is ON, it will remain on until the "timer time" has expired. If the system is in the THERMO mode, it will cancel ON and OFF as the room temperature requires until the "timer time" has expired.
3. To cancel the TIMER operation, press the TIME/TIMER button for more than 2 seconds.

OPERATIONAL NOTE: When the TIMER is used in the THERMO mode, the THERMO operation will discontinue only when the "countdown time" has expired.

LOW/BATTERY INDICATOR

The word LOW outlined by a battery on the left side of the LCD screen will appear when battery power has dropped significantly. At this time, approximately two weeks of battery power remains until the transmitter may experience partial or complete loss of functions.

NOTE: A reversed battery will activate the LOW battery icon.

TRANSMITTER

OPERATING SAFETY MONITORS: SYSTEMS SHUTDOWN

The HEARTH & HOME TECHNOLOGIES remote control operates on RF (radio frequency) signals that are sent by the TRANSMITTER (remote) to the RECEIVER that operates the appliance. It is recommended that the TRANSMITTER always be located within the 20 foot operating range, preferably in the same room in which the appliance is located.

THERMO UPDATING FEATURE –TRANSMITTER – (T/S –TX)

This HEARTH & HOME TECHNOLOGIES remote control has a THERMO UPDATING feature built into its software. The THERMO UPDATING feature operates in the following manner, but only in the THERMO and PROGRAM MODES:

The transmitter normally reads the ROOM temperature every 2 minutes checking the ROOM temperature against the SET temperature then sends a signal to the receiver.

COMMUNICATION – SAFETY – TRANSMITTER – (C/S – TX)

This HEARTH & HOME TECHNOLOGIES series remote control has a COMMUNICATION–SAFETY function built into its software. It provides an extra margin of safety when the TRANSMITTER is out of the normal 20 feet operating range of the receiver.

The COMMUNICATION – SAFETY feature operates in the following manner, in all OPERATING MODES – ON/THERMO/PROGRAM.

At all times and in all OPERATING MODES, the transmitter sends an RF signal every fifteen (15) minutes, to the receiver, indicating that the transmitter is within the normal operating range of 20 feet. Should the receiver NOT receive a transmitter signal every 15 minutes, the IC software, in the RECEIVER will begin a 2-HOUR (120-minute) countdown timing function. If during this 2-hour period, the receiver does not receive a signal from the transmitter, the receiver will shut down the fireplace being controlled by the receiver. The RECEIVER will then emit a series of rapid “beeps” for a period of 10 seconds. Then after 10 seconds of rapid beeping, the RECEIVER will continue to emit a single “beep” every 4 seconds until a transmitter signal is again received. The intermittent 4 second beeping will go on for as long as the receiver’s batteries last which could be in excess of one year.

To “reset” the RECEIVER and operate the fireplace system, you must press the MODE button on the transmitter. The word ON must display on the LCD screen. By turning the system to ON, the COMMUNICATION SAFETY operation is overridden and the system will return to normal operation depending on the MODE selected at the transmitter. The COMMUNICATION SAFETY feature will reactivate should the transmitter be taken out of the normal operating range or should the transmitter’s batteries fail or be removed.

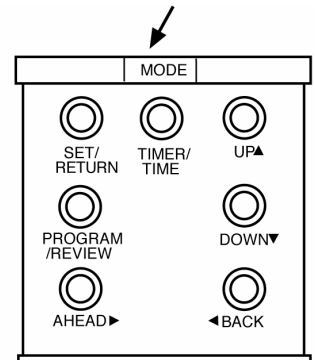
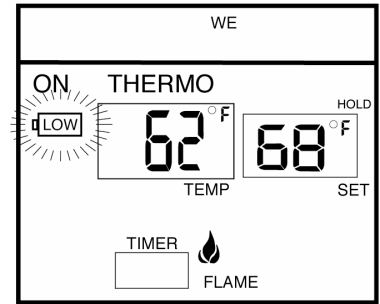

REMOTE RECEIVER

The remote receiver operates on 4 AA-size 1.5V batteries. It is recommended that ALKALINE batteries be used for longer battery life and maximum microprocessor performance. **IMPORTANT:** New or fully charged batteries are essential for proper operation of the remote receiver.

The remote receiver houses the microprocessor that responds to commands from the transmitter to control system operation. It emits one beep when it receives an ON or OFF command manually, but no beep when cycling on and off automatically in THERMO mode. The remote receiver has a 3-position slide switch for selecting the MODE of operation: ON/REMOTE/OFF.

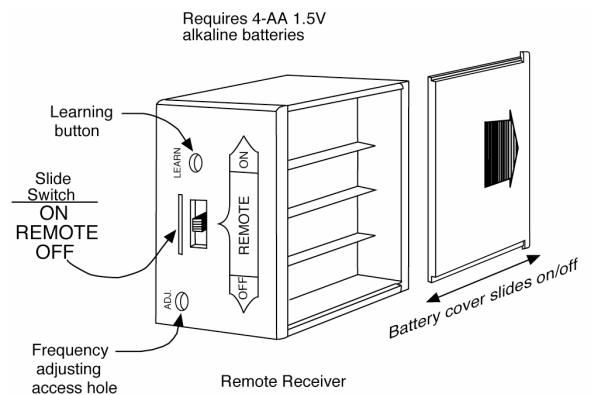

- With the slide switch in the ON position (toward the LEARN button), the system will remain on until the slide switch is placed in the OFF or REMOTE position.
- With the slide switch in the REMOTE position (centered), the system will only operate if the remote receiver receives commands **from the transmitter**.
- With the slide switch in the OFF position (away from the LEARN button), the system is off.
- **It is suggested that the slide switch be placed in the OFF position if you will be away from your home for an extended period of time. If the remote receiver is mounted out of children's reach, placing the slide switch in the OFF position also functions as a safety "lock-out" by both turning the system off and rendering the remote receiver inoperative.**

THERMO-SAFETY FEATURE – RECEIVER (T/S –RX)

This HEARTH & HOME TECHNOLOGIES remote control has a THERMO-SAFETY feature that is built into the system's RECEIVER. This feature is temperature-activated and provides an extra margin of safety when the RECEIVER is operating where ambient temperatures exceed 130⁰ F degrees inside the receiver case.

The THERMO-SAFETY feature in the RECEIVER operates in the following manner when the appliance is in operation.

The receiver is thermally protected from extreme heat conditions. Heat can have a negative effect on the operation of the receiver's microprocessors.

For REMOTE RECEIVERS that operate on BATTERY POWER, these heat conditions can cause batteries to discharge when temperatures exceed 115⁰ F. Studies show that alkaline batteries, when exposed to a constant temperature of 115⁰ F, can lose up to 50% of their operating power. When the battery cools down, it will partially recharge itself, but constant heating and cooling will reduce the battery's normal life expectancy.

When the ambient temperature at the THERMISTOR, *inside the receiver case*, reaches 130⁰ F, the THERMISTOR will automatically shut down the appliance and the RECEIVER will begin emitting a series of 4 "beeps", every 2 seconds. When the ambient temperature, at the RECEIVER, drops between 120⁰ F and 130⁰ F, the user can reactivate the appliance by pushing the MODE button on the transmitter. The word ON must display on the LCD screen. When the MODE button is pressed to ON, the THERMISTOR "resets" itself and the fireplace will begin operating again. However, the "beeping" will continue, if the ambient temperature remains between 120⁰ F and 130⁰ F. This "beeping" alerts the user that the RECEIVER should be repositioned so the ambient temperature drops below 120⁰ F.

When the temperature drops below 120⁰ F, the "beeping" will cease, providing the user has "reset" the THERMISTOR by pushing the MODE button to ON to operate the appliance, either manually or thermally. Allow sufficient time for the receiver to cool below 120⁰ F, and then press MODE button to stop beeping.

INSTALLATION INSTRUCTIONS

WARNING

This remote control system must be installed exactly as outlined in these instructions. Read all instructions completely before attempting installation. Follow instructions carefully during installation. Any modifications of the HEARTH & HOME TECHNOLOGIES remote control or any of its components will void the warrant and may be pose a fire hazard.

Do not connect any gas valve or electronic module directly to 110-120VAC power. Consult gas appliance manufacturer's instructions and wiring schematics for proper placement of all wires. All electronic modules are to be wired to manufacturer's specifications.

The following wiring diagrams are for illustration purpose only. Follow instructions from manufacturer of gas valve and/or electronic module for correct wiring procedures. Improper installation of electric components can cause damage to electronic module, gas valve and remote receiver.

INSTALLATION

The remote receiver can be either wall-mounted in a standard plastic switch box or placed on or near the fireplace hearth. Preferably, the remote receiver should be wall-mounted in a plastic switch box, as this will protect its electronic components from both the heat produced by the gas appliance and potential damage or abuse that can occur if it is left exposed on the hearth. **PROTECTION FROM EXTREME HEAT IS VERY IMPORTANT.** Like any piece of electronic equipment the remote receiver should be kept away from temperatures exceeding 120° F inside the receiver case. Battery life is also significantly shortened if batteries are exposed to high temperatures.

Make sure the remote receiver switch is in the OFF position. It is recommended that 18 gauge stranded wires (not included) be used to make connections between the terminal wiring block on the millivolt gas valve or electronic module and the wire terminals on the remote receiver. For the best results, use 18 gauge stranded wire, with no splices and measuring no longer than 20 ft.

WALL MOUNTING

Install 4 AA-size 1.5 ALKALINE batteries in the remote receiver. For best performance, remote receiver batteries should be factory fresh when installed. Very little battery power is required to operate the remote receiver, but the electronics are tuned to operate best when battery output is greater than 5.3 volts. Four new AA batteries should provide an output voltage of 6.0 to 6.2 volts. **Be sure batteries are installed with the (+) and (-) ends facing the correct direction.**

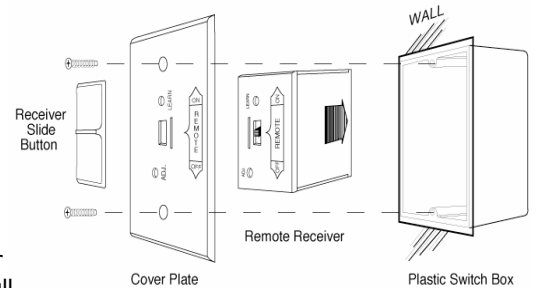

To attach Cover Plate to Receiver box: Position the receiver as shown in the diagram to the left with lower tab on cover plate inserted into groove of receiver. Pull Receiver up and snap into top tab of cover plate.

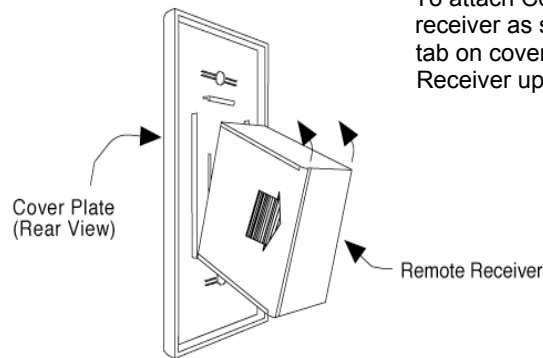

Position the cover plate so the word ON is facing up; then, install the remote receiver into the plastic switch box using the two long screws provided. Push the White Button over the receiver slide switch only after making sure the remote receiver has LEARNED the transmitter's security code (see MATCHING SECURITY CODES). **NOTE:** White Button covers both ADJ and LEARN holes when properly installed.

NOTE: The remote receiver will only respond to the transmitter when the 3-position slide button on the remote receiver is in the REMOTE position. If the system does not respond to the battery transmitter on initial use, see MATCHING SECURITY CODES, and recheck battery positions in the remote receiver.

HEARTH MOUNT

The remote receiver can be placed on the fireplace hearth or under the fireplace, behind the control access panel. Position the ambient temperature inside the receiver case where it does not exceed 120° F.

NOTE: Black Button is used for Hearth Mount applications.

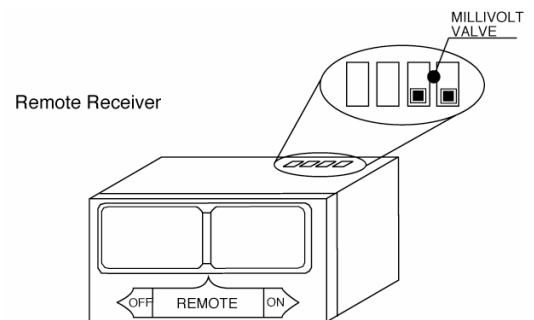

WIRING INSTRUCTIONS

A qualified electrician or a gas technician who is familiar with the gas appliance and gas valves that will be operated by this remote should install the remote control system. Incorrect wiring connections **WILL** cause damage to the gas valve or electronic module operating the gas appliance and may also damage the remote receiver.

Decide whether the remote receiver/switch will be installed in a wall mounted, plastic junction box or in the fireplace.

If mounted in the fireplace, it is important to locate the receiver in the correct location. A velcro fastener set is attached to the bottom of the Soulstice near the front and to the left of the valve. Attach the top portion of the velcro to the back center of the remote receiver. Once installed, the receiver should always be fastened to the velcro in this location.

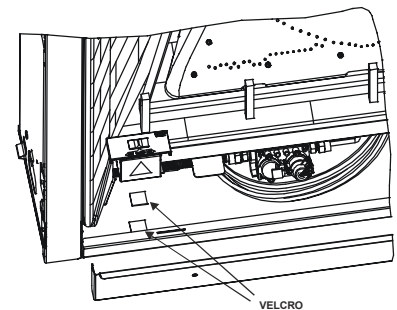

If mounted in the wall, choose a location within the reach of the 18 foot wire that is already connected to the fireplace module. Run the wire out through the 3/8" bushing located on either side of the fireplace and to a standard plastic junction box in the wall.

Cut the included wire to the correct length and discard any excess. Strip the red and white wires and insert the ends into the terminals on the remote receiver and secure them by tightening the screws. Mount the remote receiver in the wall junction box or affix it to the velcro in the fireplace.

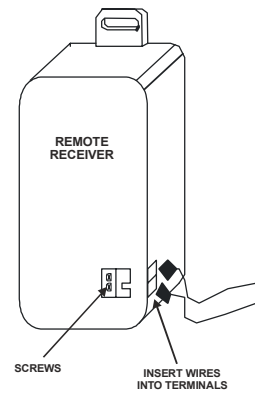

SYSTEM CHECK

- Slide the 3-position button on the remote receiver to the ON position. The spark electrode should begin sparking to ignite the pilot (the pilot may ignite after only one spark). After the pilot flame is lit, the main gas valve should open and the main gas flame should ignite.
- Slide the button to OFF. The main gas flame and pilot flame should BOTH extinguish.
- Slide the button to REMOTE (the center position), then press the MODE button on the transmitter to change the system to ON. The spark electrode should begin sparking to ignite the pilot. After the pilot is lit, the main gas valve should open and the main gas flame should ignite.
- Press the MODE button on the transmitter to OFF. The main gas flame and pilot flame should BOTH extinguish.
- Press the MODE button on the transmitter to change the system to THERMO. Advance the SET temperature on the transmitter to a temperature of at least 2°F (1°C) above the ROOM temperature displayed on the LCD screen. With this manual setting the normal thermostatic cycle is overridden and the system flame will ignite. Set the SET temperature to at least 2°F (1°C) below the room temperature and the system flame will extinguish in a few seconds. Thereafter, it should continue to cycle on and off thermostatically approximately every two minutes as the ROOM temperature changes, but only when the temperature differential between ROOM and SET temperatures differ at least 2°F (1°C). (The 2°F differential is the factory setting).

TIMER

The countdown timer will operate in either the manual ON or THERMO mode. Once the appliance is in an operating mode, set the countdown timer to turn off in 15 minutes. The timer function will allow operation to continue until the countdown "time" on the LCD screen expires. After 15 minutes elapses, the system should turn OFF.

If you have any problems with operation, recheck your connections and ensure transmitter batteries are fully charged. If no problem is found, contact the dealer where you purchased your appliance/remote control.

GENERAL INFORMATION

MATCHING SECURITY CODES

Each transmitter can use one of 1,048,576 unique security codes. It may be necessary to program the remote receiver to LEARN the security code of the transmitter upon initial use, if batteries are replaced, or if a replacement transmitter is purchased from your dealer or the factory. When matching security codes, be sure slide button on the receiver is in the REMOTE position; the code will NOT "LEARN" if the slide switch is in the ON or OFF position. Program the remote receiver to LEARN a new security code by pushing in the LEARN button on the top of the remote receiver and then pressing the MODE button on the transmitter. A change in the beeping pattern, at the receiver, indicates the transmitter's code has been programmed into the receiver. When an existing receiver is matched to a new transmitter, the new security code will overwrite the old one.

The microprocessor that controls the security code matching procedure is controlled by a timing function. If you are unsuccessful in matching the security code on the first attempt, wait 1-2 minutes before trying again – this delay allows the microprocessor to reset its timer circuitry – and try up to two or three more times.

TRANSMITTER WALL BRACKET

The transmitter can be hung on a wall using the bracket provided. Locate the bracket on an inside wall sufficiently far away from direct sources of heat such as a fireplace, incandescent lighting, or sunlight so it detects ambient room temperatures, not a single heat source. If the bracket is installed on a solid wood wall, drill 1/8" pilot holes and install with the screws provided. If it is installed on a plaster/wallboard wall, first drill two 1/4" holes into the wall, then use a hammer to tap

CHILDPROOF “LOCK –OUT” –(CP)

This HEARTH & HOME TECHNOLOGIES remote control includes a CHILDPROOF “LOCK-OUT” feature that allows the user to ‘LOCK –OUT’ operation of the fireplace, from the TRANSMITTER.

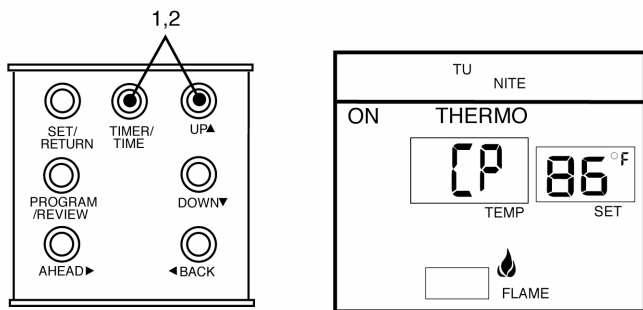

SETTING “LOCK-OUT” – (CP)

1. To activate the “LOCK-OUT” feature, press and hold the UP and TIMER buttons, together, for 5 seconds. The letters CP will appear in the TEMP frame on the LCD screen.
2. To disengage the “LOCK-OUT”, press and hold the UP and TIMER buttons, together for 5 seconds or more, and the letters CP will disappear from the LCD screen and the transmitter will return to its normal operating condition.

NOTE: If the fireplace system is already operating in the ON, THERMO or PROGRAM MODES, engaging the “LOCK-OUT” will not cancel the operating MODE. Engaging the “LOCK-OUT” prevents only the manual operation of the TRANSMITTER. If in the auto modes, the THERMO and/or PROGRAM operation will continue to operate normally. To totally “LOCK-OUT” the operation of the TRANSMITTER’S operating signals, the transmitter’s MODE must be set to OFF.

THERMO FUNCTION

When the transmitter is in the THERMO mode, it should be kept away from direct sources of heat such as fireplaces, incandescent lighting, and direct sunlight. Leaving the transmitter in direct sunlight, for example, will cause its heat-sensing diode to read the room temperature higher than it actually is; if in THERMO mode, it may not turn on the appliance even if the ambient ROOM temperature is below the SET temperature.

BATTERY LIFE

Life expectancy of the alkaline batteries in the transmitter should be at least 12 months. Replace all batteries annually. When the transmitter no longer operates the remote receiver from a distance it did previously (i.e., the transmitter’s range has decreased) or the remote receiver does not function at all, the batteries should be checked. It is important that the remote receiver batteries are fully charged and providing continuous output voltage of at least 5.3 volts. The length of the wire between the remote receiver and gas valve directly affects the operating performance of the remote system. The longer the wire, the more battery power is required to deliver signals between the remote receiver and the gas valve. Recommended length is no longer than 20 feet. The transmitter should operate with as little as 5.0 volts battery power.

TROUBLE SHOOTING

Should you encounter problems with your fireplace system, the problem may be with the fireplace itself or it could be with the HEARTH & HOME TECHNOLOGIES remote control. Review the fireplace manufacturer’s operation manual to make sure all connections are properly made. Then check the operation of the HEARTH & HOME TECHNOLOGIES remote in the following manner:

1. Make sure receiver batteries are installed properly. If one battery is installed backward, receiver will not operate in remote mode. Be sure battery output is 5.3 volts or more. (Slide switch is independent of battery condition.)
2. Be sure the transmitter’s batteries are properly installed and that the battery output is 5.0 V or more.
3. Check to make sure the transmitter is communicating with the receiver.
 - If the receiver beeps when the MODE button is depressed on the transmitter they are communicating.
 - If the receiver does not beep when the MODE button is depressed on the transmitter, you will need to teach the receiver the code of the transmitter. This is done by holding the LEARN button down on the receiver (NOTE: Slide button, White or Black, covers the Learn access hole when installed), and at the same time depress the MODE button on the transmitter. A change in the beeping pattern, at the receiver indicates the transmitter’s code has been programmed into the receiver.
4. Make sure the transmitter is within the 15 ft-20 ft range of the receiver.
5. Positioning of the receiver is important. If the receiver is “enclosed” in a metal surround, the operation of the receiver may be affected as noted below. Reposition the receiver to improve operating range. It is suggested that a heat shield be installed to protect the receiver from extreme heat. If the receiver is “enclosed” in a metal surround, this can:
 - Cause the RF signal to get lost and not communicate with the receiver.
 - Cause the working distance to be shorter than normal.

NOTE: A receiver located in an area where the ambient temperature inside the case exceeds 130°F, will cause THERMO-SAFETY feature to cut in, requiring you to reposition the receiver to stop the warning beeps, and to “reset” the receiver’s operation.
6. Due to handling and shipping of the unit, handling or dropping of the transmitter by the customer, and heat conditions to the receiver, some units may need an occasional frequency adjustment. This adjustment is made to improve the communication and operating distance between the transmitter and the receiver. See RECEIVER ADJUSTMENT.

RECEIVER ADJUSTMENT – RECOMMENDED ADJUSTMENT

NOTE: The Slide Button, White or Black, covers the ADJ access hole when installed.

- A. To adjust at the receiver, use a small slotted screwdriver. Turn the adjustment screw counter-clockwise about 5 degrees, and 1/8 turn. This should correct the distance problem.
- B. If that does not correct the problem, return adjustment screw to original position and then turn adjustment screw 5 degrees clockwise.

This adjustment is like tuning your radio. If you keep turning the adjustment screw, in either direction, you will go past the proper setting (tuning).

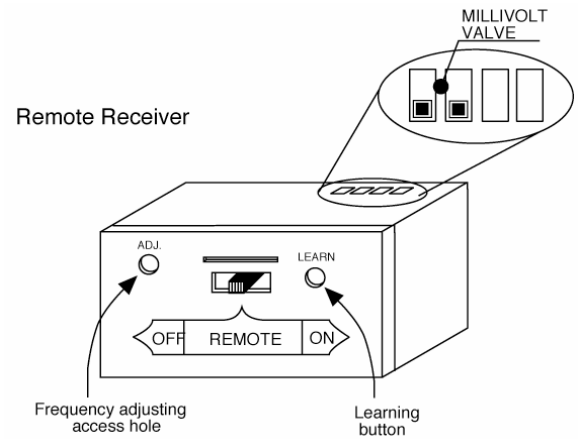

SPECIFICATIONS

BATTERIES: Transmitter 6V- 4 ea. AAA 1.5V, Alkaline
Remote Receiver 6V –4ea. AA 1.5 Alkaline
Operating Frequency: 303.8MHZ

FCC ID No.'s: transmitter –K9L3001TX; receiver – K9L3001RX
Canadian ISC ID No.'s: transmitter –2439 102 760; receiver – 2439 102 760A

FCC REQUIREMENTS

NOTE: THE MANUFACTURER IS NOT RESPONSIBLE FOR ANY RADIO OR TV INTERFERENCE CAUSED BY UNAUTHORIZED MODIFICATIONS TO THIS EQUIPMENT. SUCH MODIFICATIONS COULD VOID THE USER'S AUTHORITY TO OPERATE THE EQUIPMENT.