

Models:

Pier-HVB-IPI

ST-HVB-IPI

LCOR-HVB-IPI

RCOR-HVB-IPI



Underwriters
Laboratories Listed

**This appliance has been retired.
Service parts pages within have been removed.
For replacement parts, please refer to the individual
service parts list located on the brand websites.**

READ THIS MANUAL BEFORE INSTALLING OR OPERATING THIS APPLIANCE. THIS *INSTALLERS GUIDE* MUST BE LEFT WITH APPLIANCE FOR FUTURE REFERENCE.

WARNING: IF THE INFORMATION IN THESE INSTRUCTIONS IS NOT FOLLOWED EXACTLY, A FIRE OR EXPLOSION MAY RESULT CAUSING PROPERTY DAMAGE, PERSONAL INJURY, OR DEATH.

- Do not store or use gasoline or other flammable vapors and liquids in the vicinity of this or any other appliance.
- **What to do if you smell gas**
 - Do not try to light any appliance.
 - Do not touch any electrical switch.
 - Do not use any phone in your building.
 - Immediately call your gas supplier from a neighbor's phone. Follow the gas supplier's instructions.
 - If you cannot reach your gas supplier, call the fire department.
- Installation and service must be performed by a qualified installer, service agency, or the gas supplier.

WARNING: IMPROPER INSTALLATION, ADJUSTMENT, ALTERATION, SERVICE OR MAINTENANCE CAN CAUSE INJURY OR PROPERTY DAMAGE. REFER TO THIS MANUAL. FOR ASSISTANCE OR ADDITIONAL INFORMATION CONSULT A QUALIFIED INSTALLER, SERVICE AGENCY, OR THE GAS SUPPLIER.

1. This appliance may be installed in an aftermarket, permanently located, manufactured (mobile) home, where not prohibited by local codes.
2. This appliance is only for use with the type of gas indicated on the rating plate. This appliance is not convertible for use with other gases, unless a certified kit is used.

In the Commonwealth of Massachusetts:

- installation must be performed by a licensed plumber or gas fitter;
- a CO detector shall be installed in the room where the appliance is installed.

Printed in U.S.A. Copyright 2006

Heat & Glo, a brand of Hearth & Home Technologies Inc.
20802 Kensington Boulevard, Lakeville, MN 55044

Please contact your Heat-N-Glo dealer with any questions or concerns. For the number of your nearest Heat-N-Glo dealer, please call 1-888-427-3973.

This product may be covered by one or more of the following patents: (United States) 4593510, 4686807, 4766876, 4793322, 4811534, 5000162, 5016609, 5076254, 5113843, 5191877, 5218953, 5263471, 5328356, 5341794, 5347983, 5429495, 5452708, 5542407, 5601073, 5613487, 5647340, 5688568, 5762062, 5775408, 5890485, 5931661, 5941237, 5947112, 5996575, 6006743, 6019099, 6048195, 6053165, 6145502, 6170481, 6237588, 6296474, 6374822, 6413079, 6439226, 6484712, 6543698, 6550687, 6601579, 6672860, 6688302B2, 6715724B2, 6729551, 6736133, 6748940, 6748942, 6769426, 6774802, 6796302, 6840261, 6848441, 6863064, 6866205, 6869278, 6875012, 6880275, 6908039, 6919884, D320652, D445174, D462436; (Canada) 1297749, 2195264, 2225408, 2313972; (Australia) 780250, 780403, 1418504 or other U.S. and foreign patents pending.

Safety and Warning Information

 **READ** and **UNDERSTAND** all instructions carefully before starting the installation. **FAILURE TO FOLLOW** these installation instructions may result in a possible fire hazard and will void the warranty.

 Prior to the first firing of the fireplace, **READ** the Using Your Fireplace section of the *Owners Guide*.

 **DO NOT USE** this appliance if any part has been under water. Immediately **CALL** a qualified service technician to inspect the unit and to replace any part of the control system and any gas control which has been under water.

 **THIS UNIT IS NOT FOR USE WITH SOLID FUEL.**

 Installation and repair should be **PERFORMED** by a qualified service person. The appliance and venting system should be **INSPECTED** before initial use and at least annually by a professional service person. More frequent cleaning may be required due to excessive lint from carpeting, bedding material, etc. It is **IMPERATIVE** that the unit's control compartment, burners, and circulating air passageways **BE KEPT CLEAN** to provide for adequate combustion and ventilation air.

 Always **KEEP** the appliance clear and free from combustible materials, gasoline, and other flammable vapors and liquids.

 **NEVER OBSTRUCT** the flow of combustion and ventilation air. Keep the front of the appliance **CLEAR** of all obstacles and materials for servicing and proper operations.

 Due to the high temperature, the appliance should be **LOCATED** out of traffic areas and away from furniture and draperies. Clothing or flammable material **SHOULD NOT BE PLACED** on or near the appliance.

 Children and adults should be **ALERTED** to the hazards of high surface temperature and should **STAY AWAY** to avoid burns or clothing ignition. Young children should be **CAREFULLY SUPERVISED** when they are in the same room as the appliance.

 These units **MUST** use one of the vent systems described in the Installing the Fireplace section of the *Installers Guide*. **NO OTHER** vent systems or components **MAY BE USED**.

 This gas fireplace and vent assembly **MUST** be vented directly to the outside and **MUST NEVER** be attached to a chimney serving a separate solid fuel burning appliance. Each gas appliance **MUST USE** a separate vent system. Common vent systems are **PROHIBITED**.

 **INSPECT** the external vent cap on a regular basis to make sure that no debris is interfering with the air flow.

 The glass door assembly **MUST** be in place and sealed, and the trim door assembly **MUST** be in place on the fireplace before the unit can be placed into safe operation.

 **DO NOT OPERATE** this appliance with the glass door removed, cracked, or broken. Replacement of the glass door should be performed by a licensed or qualified service person. **DO NOT** strike or slam the glass door.

 The glass door assembly **SHALL ONLY** be replaced as a complete unit, as supplied by the gas fireplace manufacturer. **NO SUBSTITUTE** material may be used.

 **DO NOT USE** abrasive cleaners on the glass door assembly. **DO NOT ATTEMPT** to clean the glass door when it is hot.

 Turn off the gas before servicing this appliance. It is recommended that a qualified service technician perform an appliance check-up at the beginning of each heating season.

 Any safety screen or guard removed for servicing must be replaced before operating this appliance.

 **DO NOT** place furniture or any other combustible household objects within 36 inches of the fireplace front.

Table of Contents

Safety and Warning Information	2
Service Parts List	4
Approvals and Codes	13
Appliance Certification	13
Installation Codes	13
High Altitude Installations	13
Getting Started	14
Introducing the Heat & Glo Gas Fireplaces	14
Pre-install Preparation	14
Installing the Fireplace	18
Step 1. Locating the Fireplace	18
Step 2. Framing the Fireplace	18
Step 3. Installing the Vent System	21
A. Vent System Approvals	21
→ B. Installing Vent Components	28
C. Vent Termination	30
Step 4. Positioning, Leveling, and Securing the Fireplace	33
Step 5. The Gas Control System	33
Step 6. The Gas Supply Line	34
Step 7. Gas Pressure Requirements	34
Step 8. Wiring the Fireplace	35
Step 9. Finishing	37
Step 10. Installing Trim, Logs & Ember Material	38
Installing the Trim	38
Positioning the Logs	38
Shutter Settings	38
Glass Specifications	38
Placing the Ember Material	39
Ember Light Bulb Replacement	39
Step 11. Before Lighting the Fireplace	40
Step 12. Lighting the Fireplace	40
After the Installation	40
Maintaining and Servicing Your Fireplace	41

→ = Contains updated information.

1

Approvals and Codes

Appliance Certification

The Heat & Glo fireplace models discussed in this *Installers Guide* have been tested to certification standards and listed by the applicable laboratories.

Certification

MODELS: PIER-HVB-IPI, ST-HVB-IPI,
LCOR-HVB-IPI, RCOR-HVB-IPI
LABORATORY: Underwriters Laboratories
TYPE: Vented Gas Fireplace Heater
STANDARD: ANSI Z21.88•CGA2.22•UL307B

Installation Codes

The fireplace installation must conform to local codes. Before installing the fireplace, consult the local building code agency to ensure that you are in compliance with all applicable codes, including permits and inspections.

In the absence of local codes, the fireplace installation must conform to the National Fuel Gas Code ANSI Z223.1 (in the United States) or the CAN/CGA-B149 Installation Codes (in Canada). The appliance must be electrically grounded in accordance with local codes or, in the absence of local codes with the National Electric Code ANSI/NFPA No. 70 (in the United States), or to the CSA C22.1 Canadian Electric Code (in Canada).

These models may be installed in a bedroom or bed-sitting room in the U.S.A. and Canada.

High Altitude Installations

U.L. Listed gas appliances are tested and approved without requiring changes for elevations from 0 to 2,000 feet in the U. S. A. and in Canada.

When installing this appliance at an elevation above 2,000 feet, it may be necessary to decrease the input rating by changing the existing burner orifice to a smaller size. Input rate should be reduced by 4% for each 1000 feet above a 2000 foot elevation in the U.S.A. or 10% for elevations between 2000 and 4500 feet in Canada. If the heating value of the gas has been reduced, these rules do not apply. To identify the proper orifice size, check with the local gas utility.

If installing this appliance at an elevation above 4,500 feet (in Canada), check with local authorities.



Heat & Glo Quality Systems
registered by SGS ICS

2

Getting Started

Introducing the Heat & Glo Gas Fireplaces

Heat & Glo direct vent gas fireplaces are designed to operate with all combustion air siphoned from outside of the building and all exhaust gases expelled to the outside.

The information contained in this *Installers Guide*, unless noted otherwise, applies to all models and gas control systems. Gas fireplace diagrams, including the dimensions, are shown in this section.

Pre-install Preparation

This gas fireplace and its components are tested and safe when installed in accordance with this *Installers Guide*. Report to your dealer any parts damaged in shipment, particularly the condition of the glass. **Do not install any unit with damaged, incomplete, or substitute parts.**

The vent system components are shipped in separate packages. The gas logs are packaged separately and must be field installed.

Read all of the instructions before starting the installation. Follow these instructions carefully during the installation to ensure maximum safety and benefit. Failure to follow these instructions will void the owner's warranty and may present a fire hazard.

The Heat & Glo Warranty will be voided by, and Heat & Glo disclaims any responsibility for, the following actions:

- Installation of any damaged fireplace or vent system component.
- Modification of the fireplace or direct vent system.
- Installation other than as instructed by Heat & Glo.
- Improper positioning of the gas logs or the glass door.
- Installation and/or use of any component part not manufactured and approved by Heat & Glo, notwithstanding any independent testing laboratory or other party approval of such component part or accessory.

ANY SUCH ACTION MAY POSSIBLY CAUSE A FIRE HAZARD.

When planning a fireplace installation, it's necessary to determine:

- Where the unit is to be installed.
- The vent system configuration to be used.
- Gas supply piping.
- Electrical wiring.
- Framing and finishing details.
- Whether optional accessories—devices such as a fan, wall switch, or remote control—are desired.

If the fireplace is to be installed on carpeting or tile, or on any combustible material other than wood flooring, the fireplace should be installed on a metal or wood panel that extends the full width and depth of the fireplace.

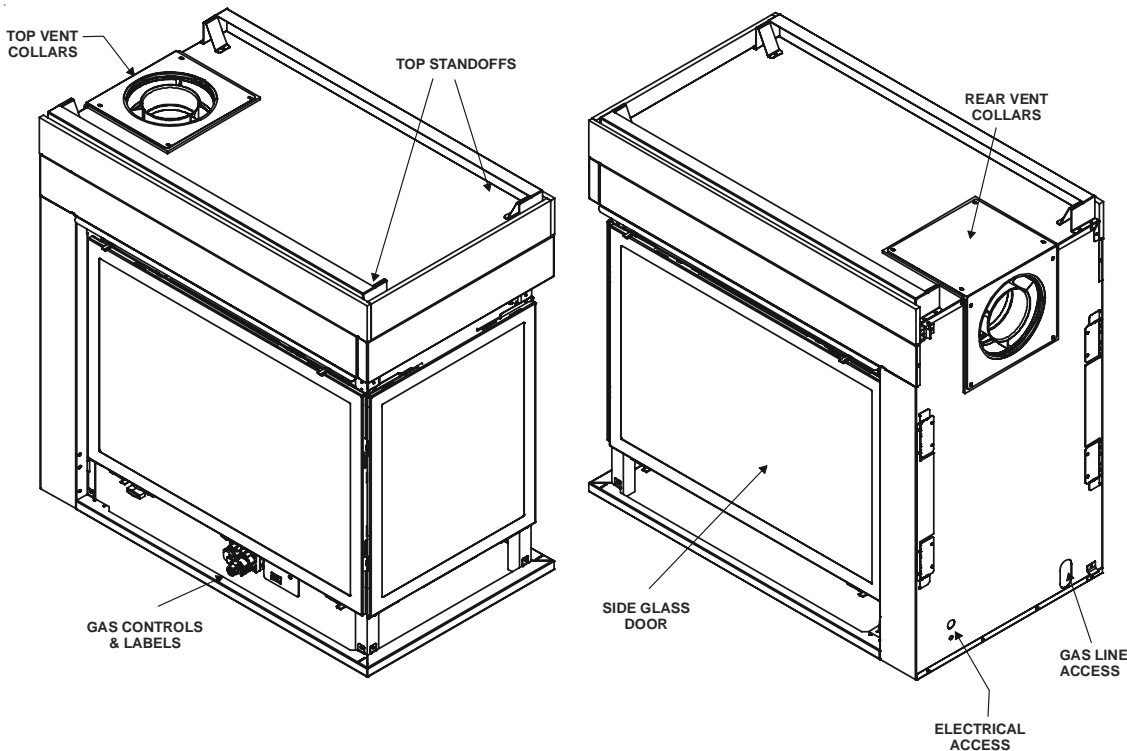
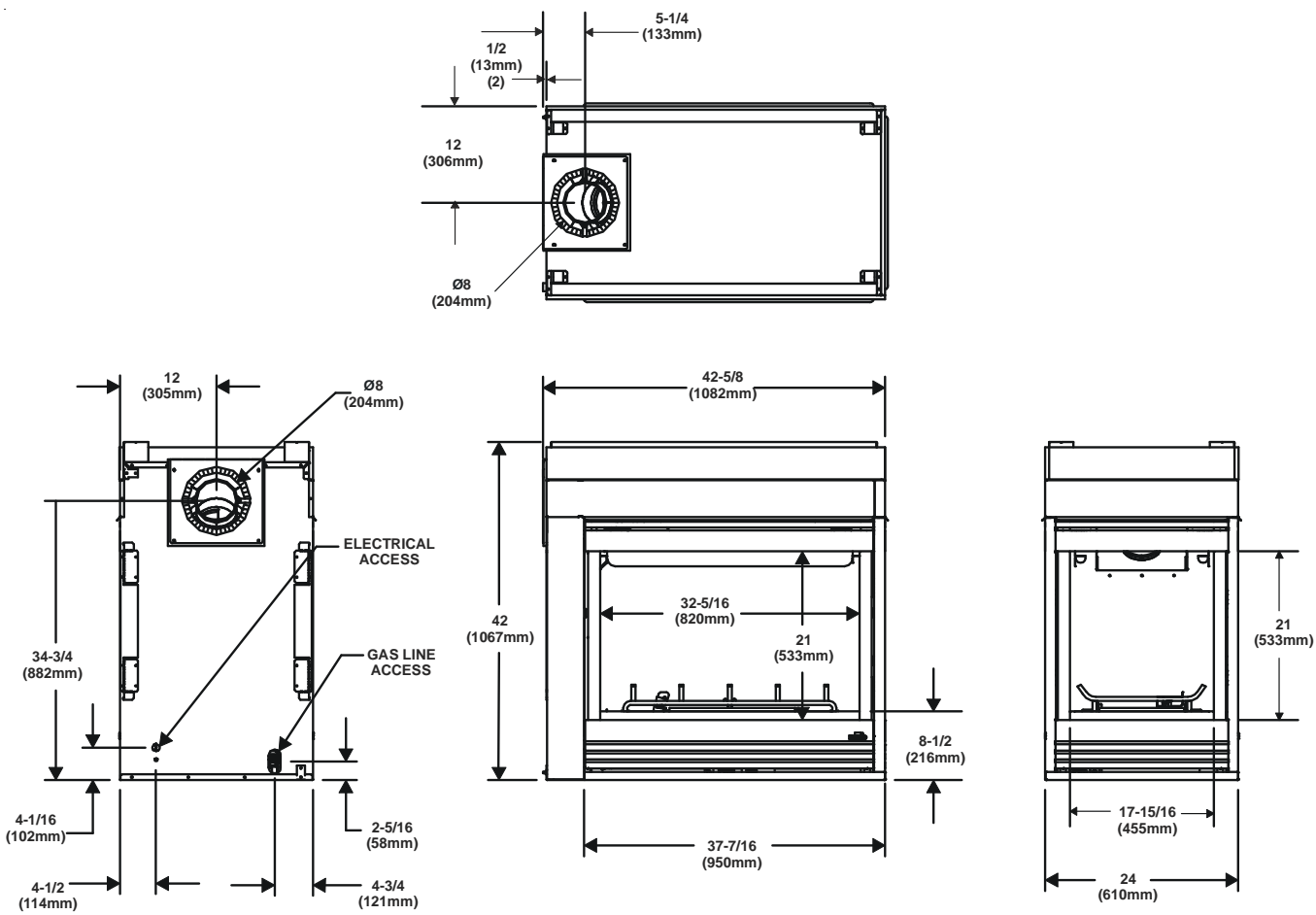

Figure 1. Diagram of the PIER-HVB-IPI

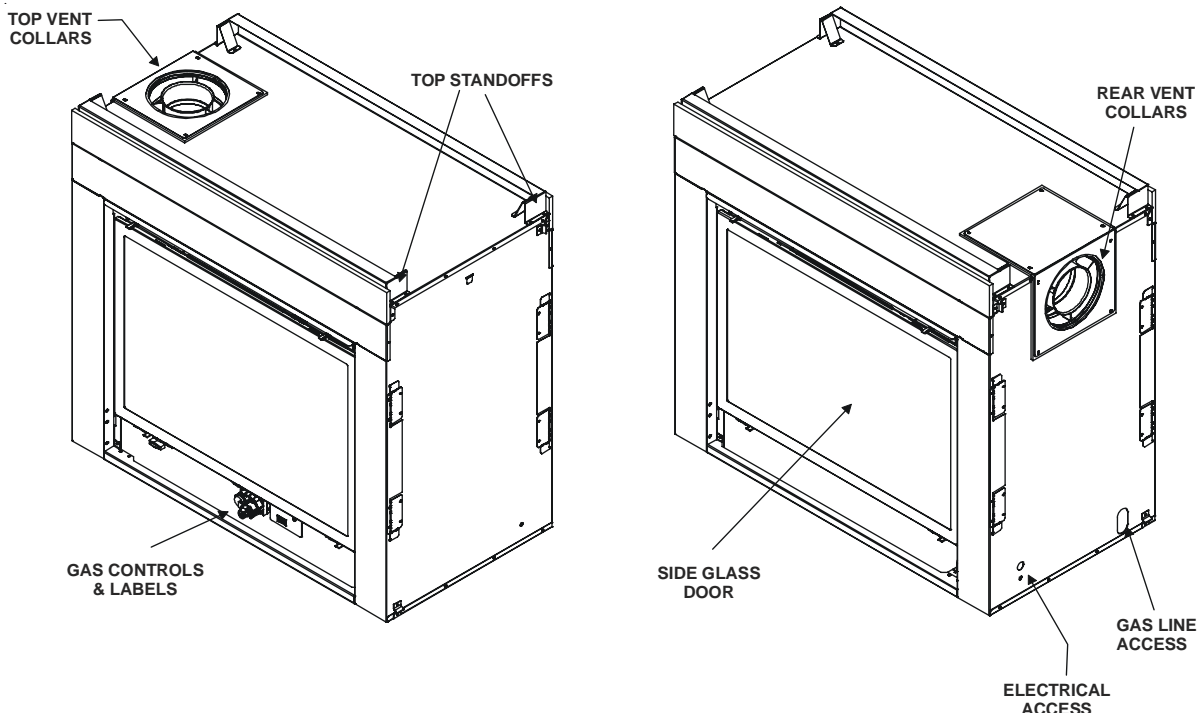
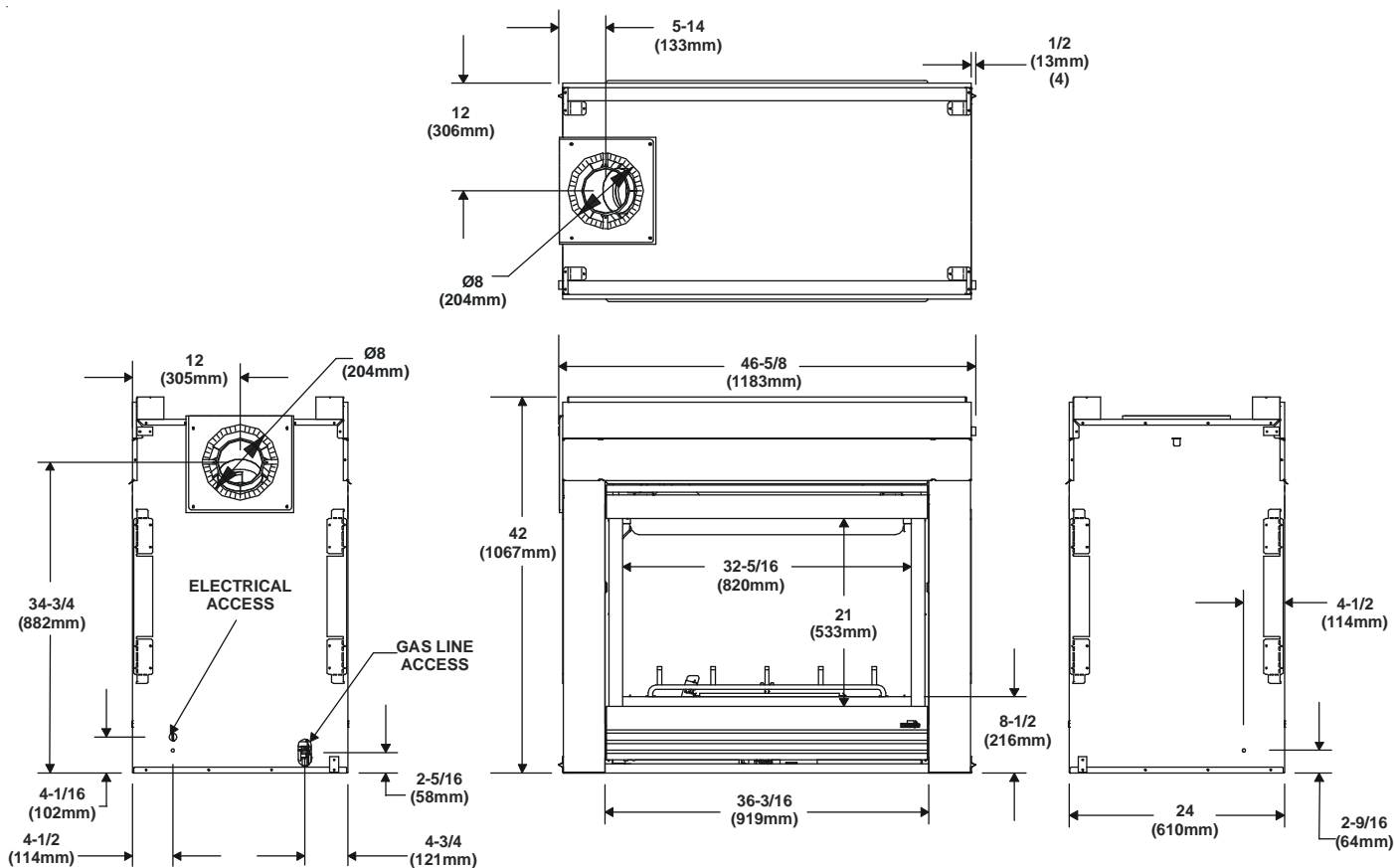

Figure 2. Diagram of the ST-HVB-IPI

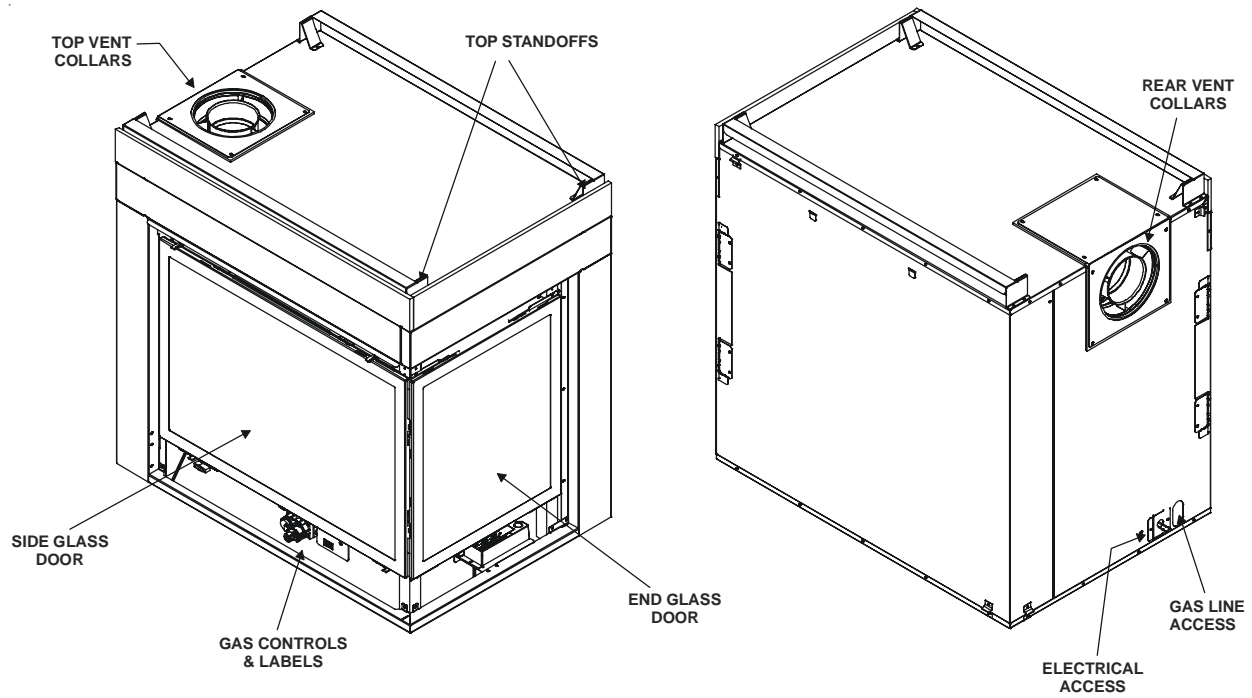
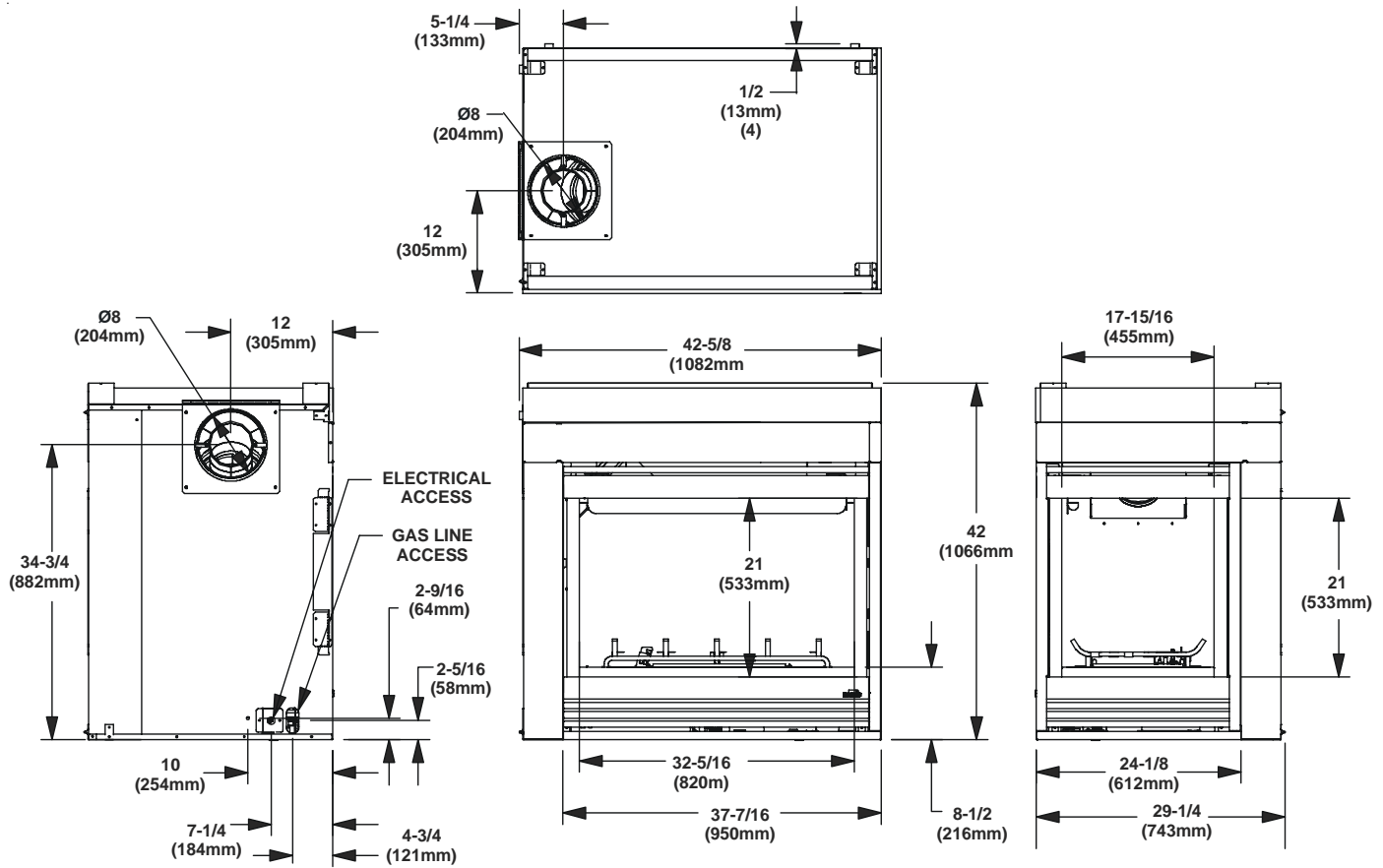

Figure 3. Diagram of the LCOR-HVB-IPI and RCOR-HVB-IPI

3

Installing the Fireplace

Step 1. Locating the Fireplace

The diagram below shows space and clearance requirements for locating a fireplace within a room.

→ **Note:** Refer to Figure 4B for dimensions and appliance locations if installing a Pier-HVB unit with a **Catalina shelf and/or marble package**.

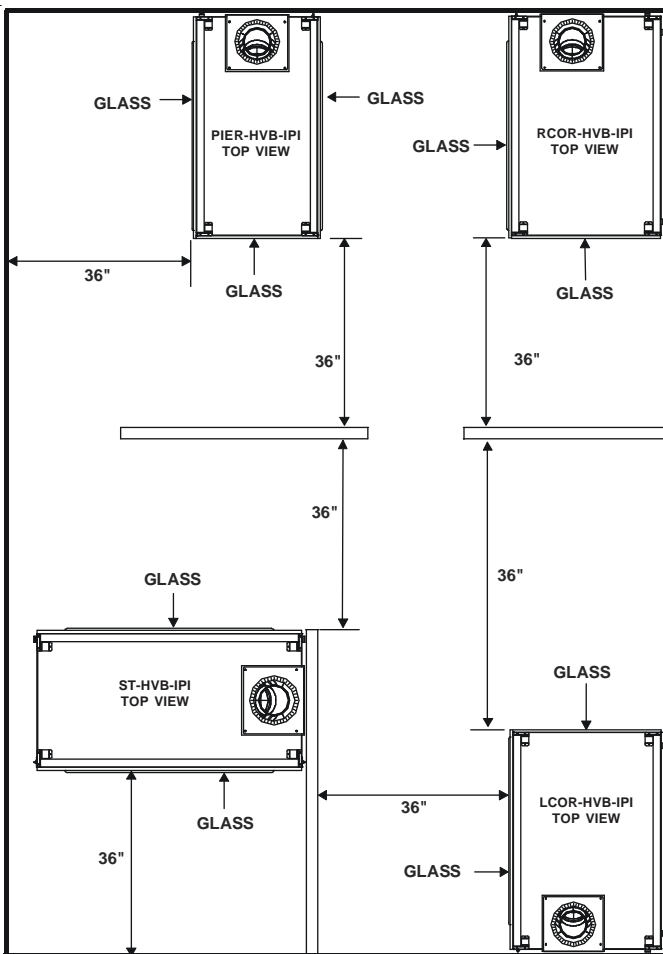
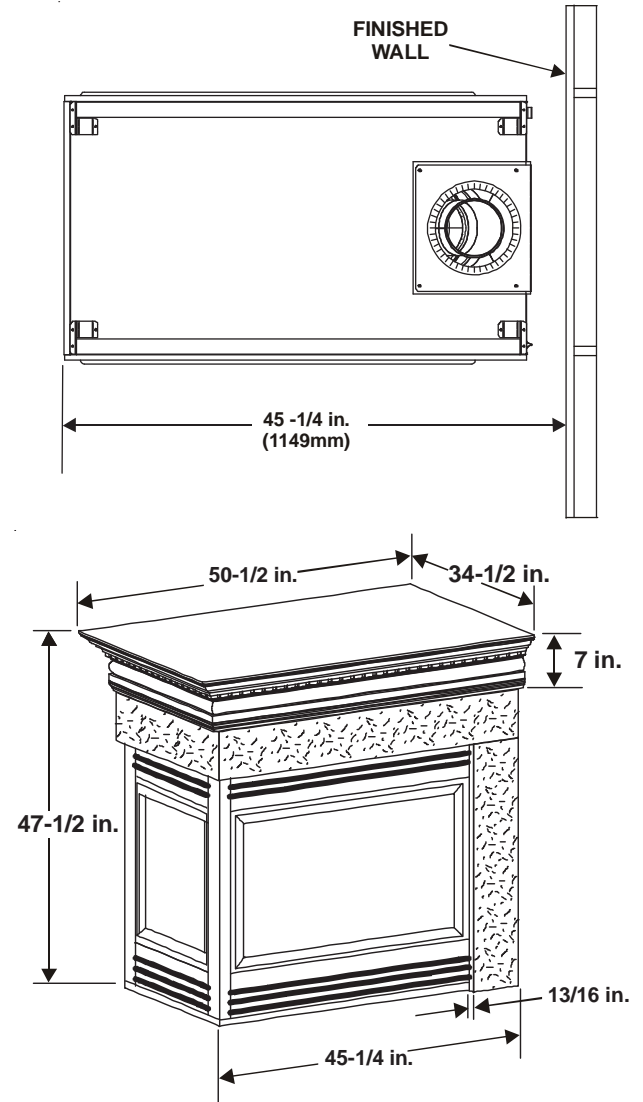

Figure 4A. Fireplace Dimensions and Locations

Note: Refer to the Catalina installation instruction included with kit for assembly and installation.

Note: This location diagram **MUST** be followed when installing a Pier-HVB with a Catalina shelf/marble package since the fireplace is installed further from finished wall.



Marble sizes (inches):

- Header 26 x 8
- Side headers 45-1/2 x 8
- Legs 33-1/2 x 7

Figure 4B. Fireplace Locations/Dimensions with Catalina Shelf/Marble Package ONLY

Clearance Requirements

The top, back, and sides of the fireplace are defined by stand-offs. The minimum clearance to a perpendicular wall extending past the face of the fireplace is one inch (25 mm). The metal ends of the fireplace may **NOT** be recessed into combustible construction.

Minimum Clearances from the Fireplace to Combustible Materials		
	<u>Inches</u>	<u>mm</u>
Glass Sides or Ends	36	914
Floor	0	0
Rear Vent	1/2	13
Metal Sides or Ends	1/2	13
Top	2 1/2	64
Ceiling*	31	787

* The clearance to the ceiling is measured from the top of the unit, excluding the standoffs (see Figures 37 & 38).

The distance from the unit to combustible construction is to be measured from the unit outer wrap surface to the combustible construction, **NOT** from the screw heads that secure the unit together.

Minimum Clearances from the Vent Pipe to Combustible Materials		
	<u>Inches</u>	<u>mm</u>
Vertical Sections	1	25
Horizontal Sections		
Top	3	75
Bottom	1	25
Sides	1	25
At Wall Firestops		
Top	2 1/2	63.7
Bottom	1/2	13
Sides	1	25

For minimum clearances, see the direct vent termination clearance diagrams on pages 31 and 32 in this manual.

Step 2. Framing the Fireplace

Fireplace framing can be built before or after the fireplace is set in place. Framing should be positioned to accommodate wall coverings and fireplace facing material. The diagram below shows framing reference dimensions.

CAUTION: MEASURE FIREPLACE DIMENSIONS AND VERIFY FRAMING METHODS AND WALL COVERING DETAILS BEFORE FRAMING.

WARNING: FRAMING DIMENSIONS ASSUME USE OF 1/2 INCH THICK WALL COVERING MATERIALS ON EXTERIOR OF FRAMING ONLY AND NO SHEETROCK ON INTERIOR OF FRAMING.

Shows center of 10" x 12" vent framing holes for top and rear venting. The center of the hole is one inch (25.4mm) above the center of the horizontal vent pipe.

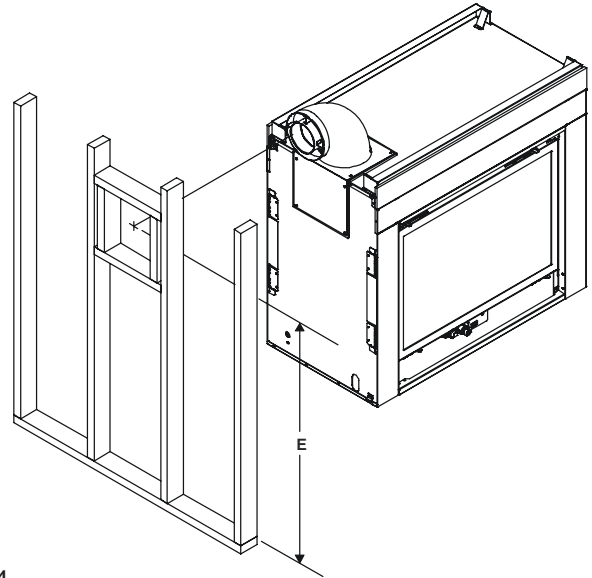
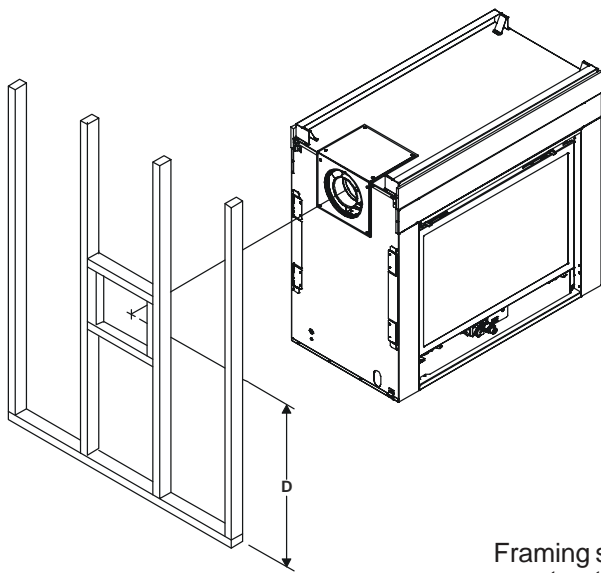

Framing should be constructed of 2 X 4 lumber or heavier.

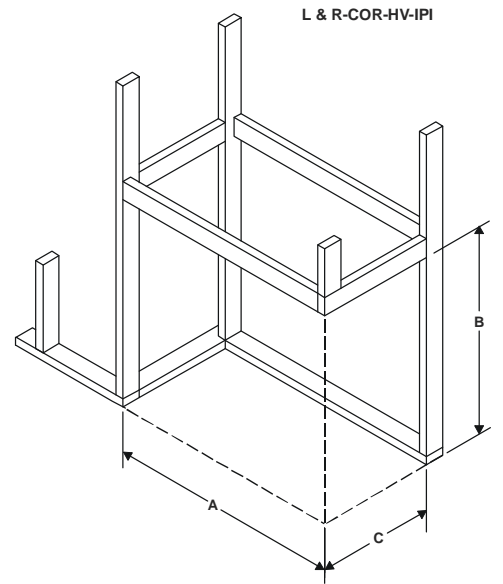
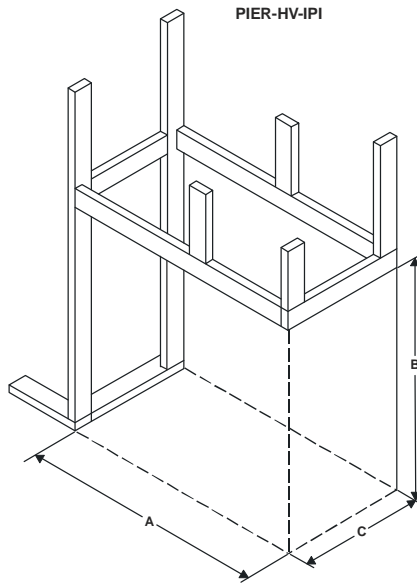
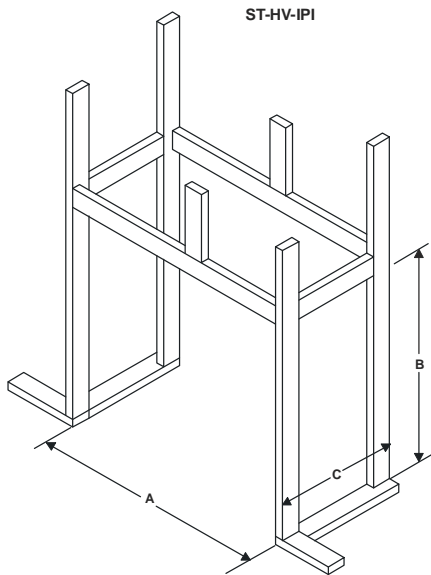

Model	A	B	C	D	E
PIER-HVB-IP1	42-1/8	42-1/2	23	35-3/4	48
ST-HVB-IP1	47-5/8	42-1/2	23	35-3/4	48
L&RCOR-HVB-IP1	42-1/8	42-1/2	28-3/4	35-3/4	48

NOTE: DIMENSIONS SHOWN IN INCHES

Figure 5. Framing Dimensions

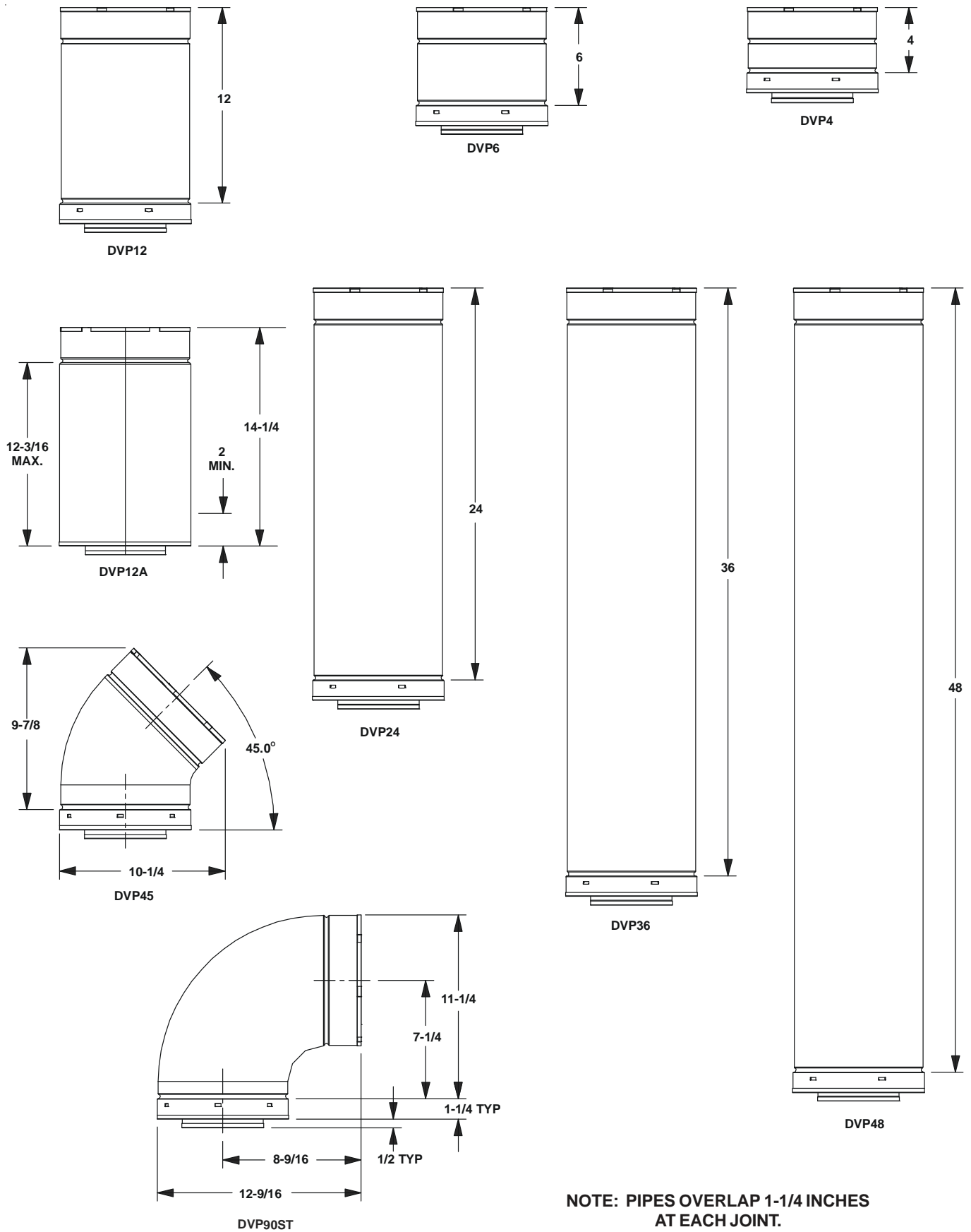

Figure 6. DVP-Series Direct Vent Component Specifications (5-inch inner pipe / 8-inch outer pipe)

Step 3. Installing the Vent System

A. Vent System Approvals

These models are approved to use DVP series direct vent pipe components and terminations (see Figures 6 and 7). Approved vent system components are labeled for identification. This pipe is tested and listed as an approved component of the fireplace. The pipe is tested to be run inside an enclosed wall. There is no requirement for inspection openings at each joint within the wall. There is no required pitch for horizontal vent runs. **NO OTHER VENTING SYSTEMS OR COMPONENTS MAY BE USED.**

Detailed installation instructions are included with each vent termination kit and should be used in conjunction with this *Installers Guide*.

The flame and ember appearance may vary based on the type of fuel burned and the venting configuration used.

Identifying Vent Components

The vent systems installed on this gas fireplace may include one, two, or three 90° elbow assemblies. The relationships of vertical rise to horizontal run in vent configurations using 90° elbows **MUST BE** strictly adhered to. The rise to run relationships are shown in the venting drawings and tables. Refer to the diagrams on the next several pages.

NOTE: Two 45° elbows may be used in place of one 90° elbow. Rise to run ratios in the vent system must be followed if 45° elbows are used.

This model has a 45° elbow built into it. It may be positioned to vent either horizontal or vertical. Depending on the installation, decide which direction the elbow should be facing. Remove the 8 screws from the corner cover plate. Position the 45° elbow as desired and replace the corner cover plate with the 8 screws.

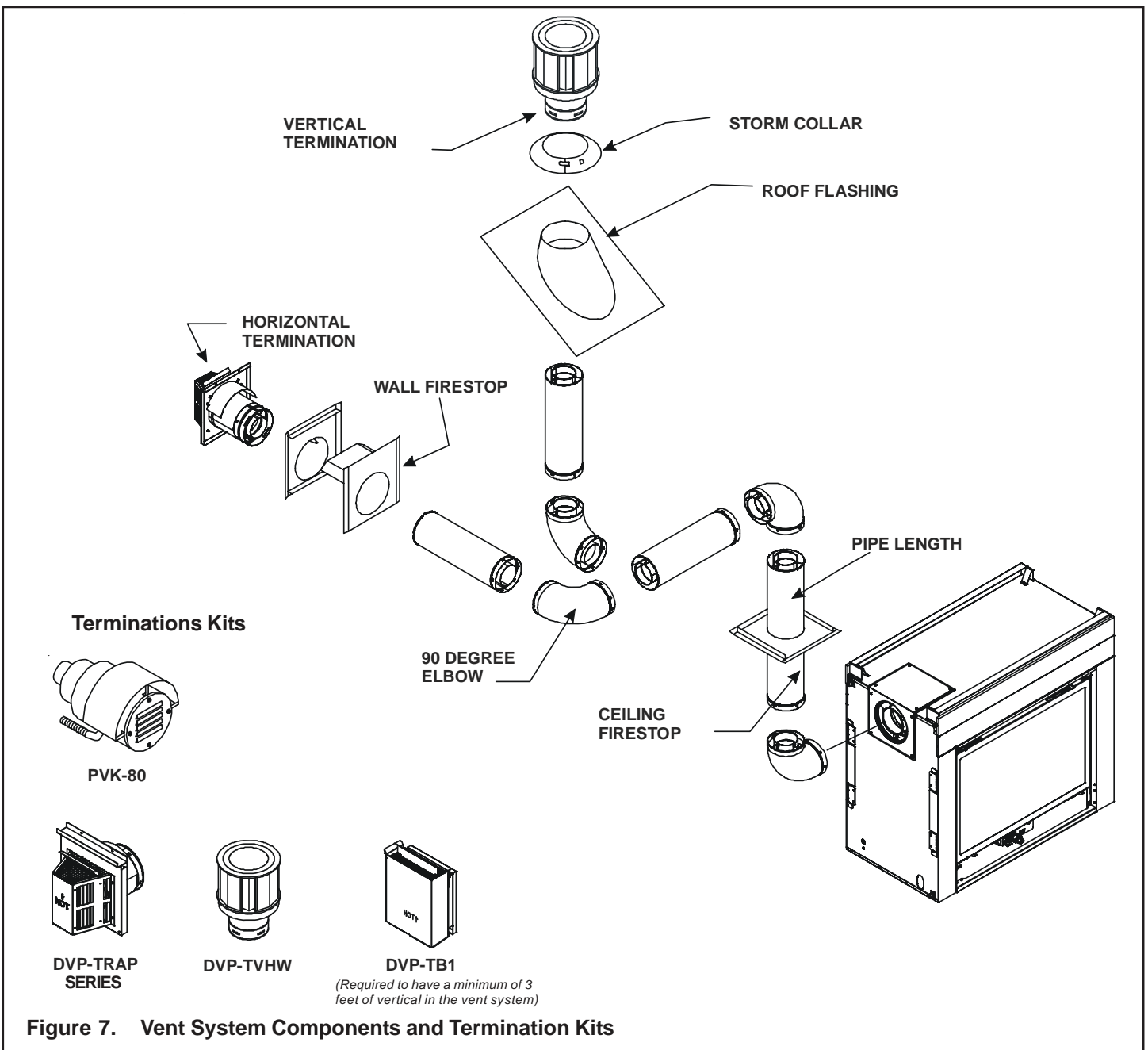
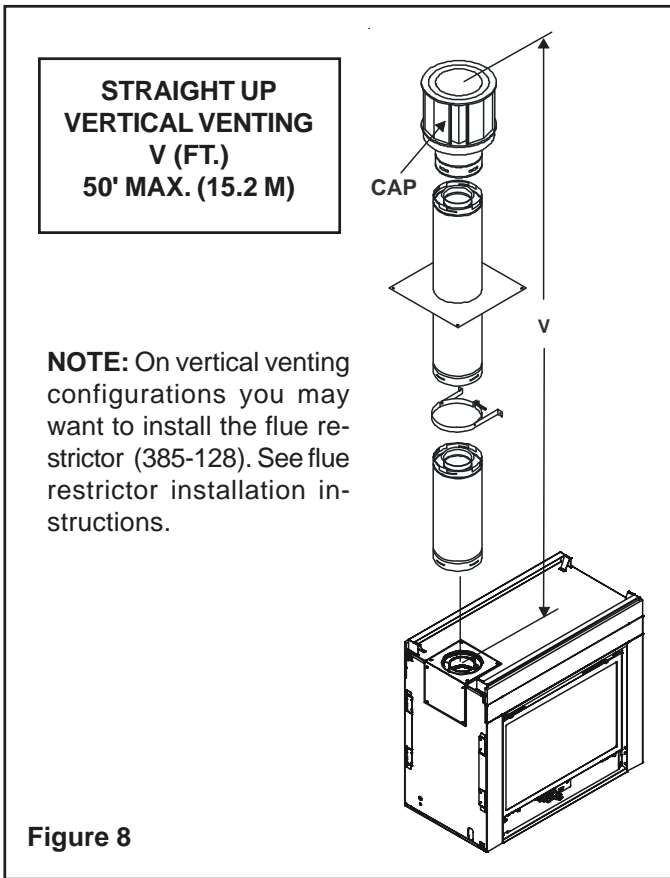
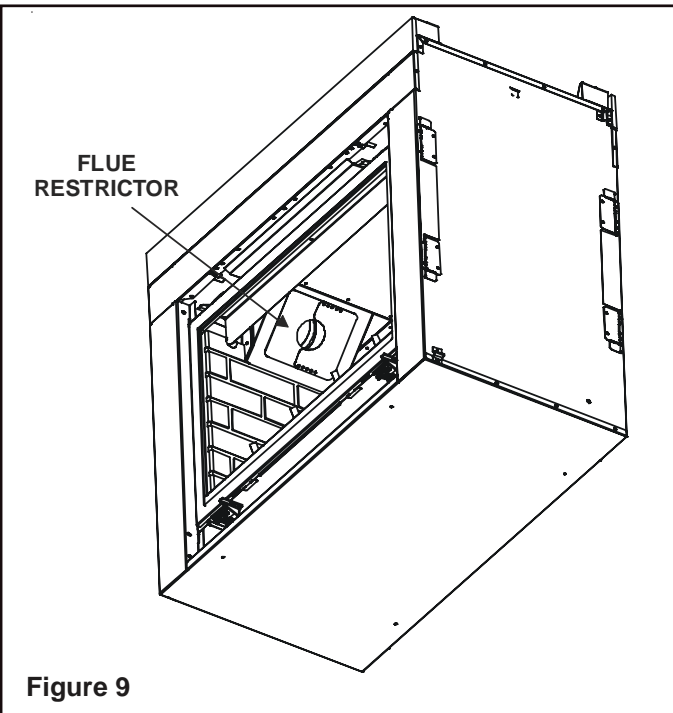

Figure 7. Vent System Components and Termination Kits



Flue Restrictor Instructions

1. Locate the Flue Restrictor which is in the manual bag.



2. Break the Flue Restrictor into two pieces. Do this by bending the part back and forth until it breaks (see Figure 10).

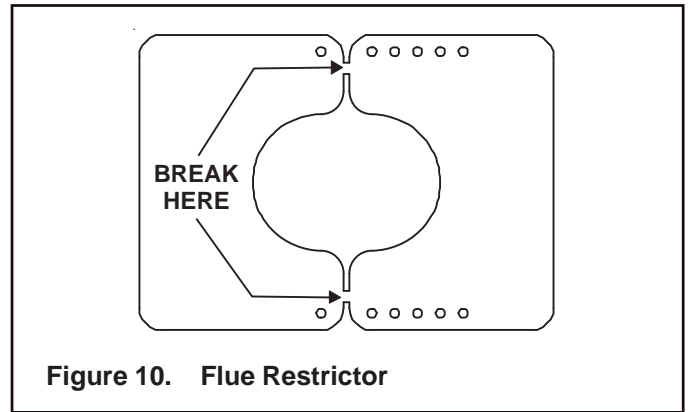

3. Match the amount of vertical in the system with the chart to find the appropriate position to set the Flue Restrictor.

- CHART -	
Vertical	Settings
4'	1-1
8'	1-2
15'	2-2
20'	2-3
25'	3-3
30'	4-3
35'	4-4
40'	4-4
50'	4-5

4. Center the Flue Restrictor on vent and secure in place using two self-tapping screws (see Figure 11).

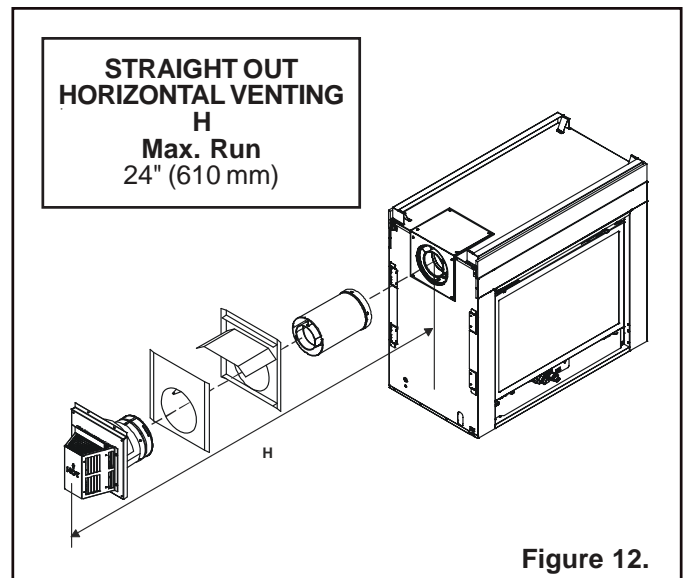
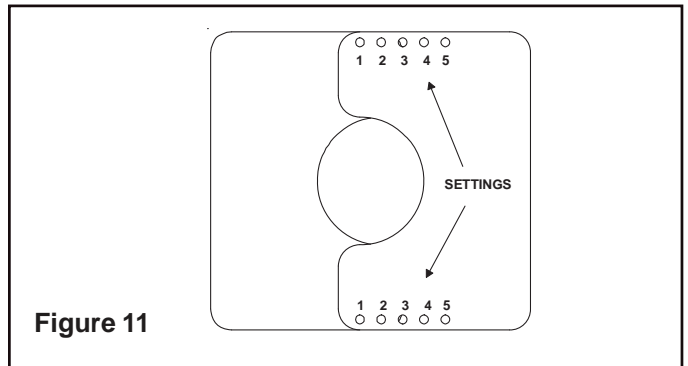

NATURAL GAS - VENTING WITH ONE 90° ELBOW

V (FT.)	H (FT.)
1' MIN. (305mm)	3' MAX. (914mm)
2' MIN. (610mm)	6' MAX. (1.83m)
3' MIN. (914mm)	9' MAX. (2.7m)
4' MIN. (1.22m)	12' MAX. (3.6m)
5' MIN. (1.5m)	15' MAX. (4.5m)
6' MIN. (1.83m)	18' MAX. (5.5m)
V + H = 50' MAX. (15.2m)	

PROPANE - VENTING WITH ONE 90° ELBOW

V (FT.)	H (FT.)
1' MIN. (305mm)	2' MAX. (610mm)
2' MIN. (610mm)	4' MAX. (1.22m)
3' MIN. (914mm)	6' MAX. (1.83m)
4' MIN. (1.22m)	8' MAX. (2.4m)
5' MIN. (1.5m)	10' MAX. (3.0m)
6' MIN. (1.83m)	12' MAX. (3.6m)
V + H = 50' MAX. (15.2m)	

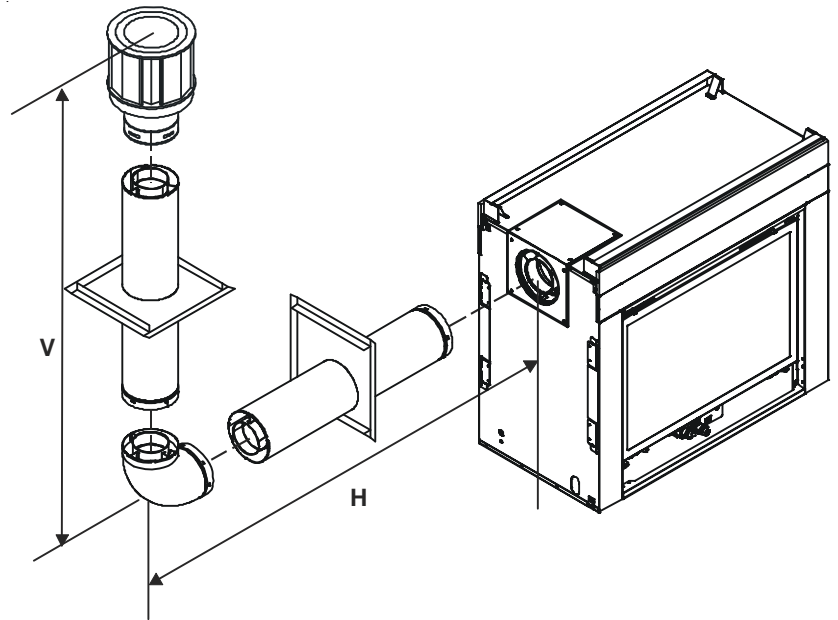
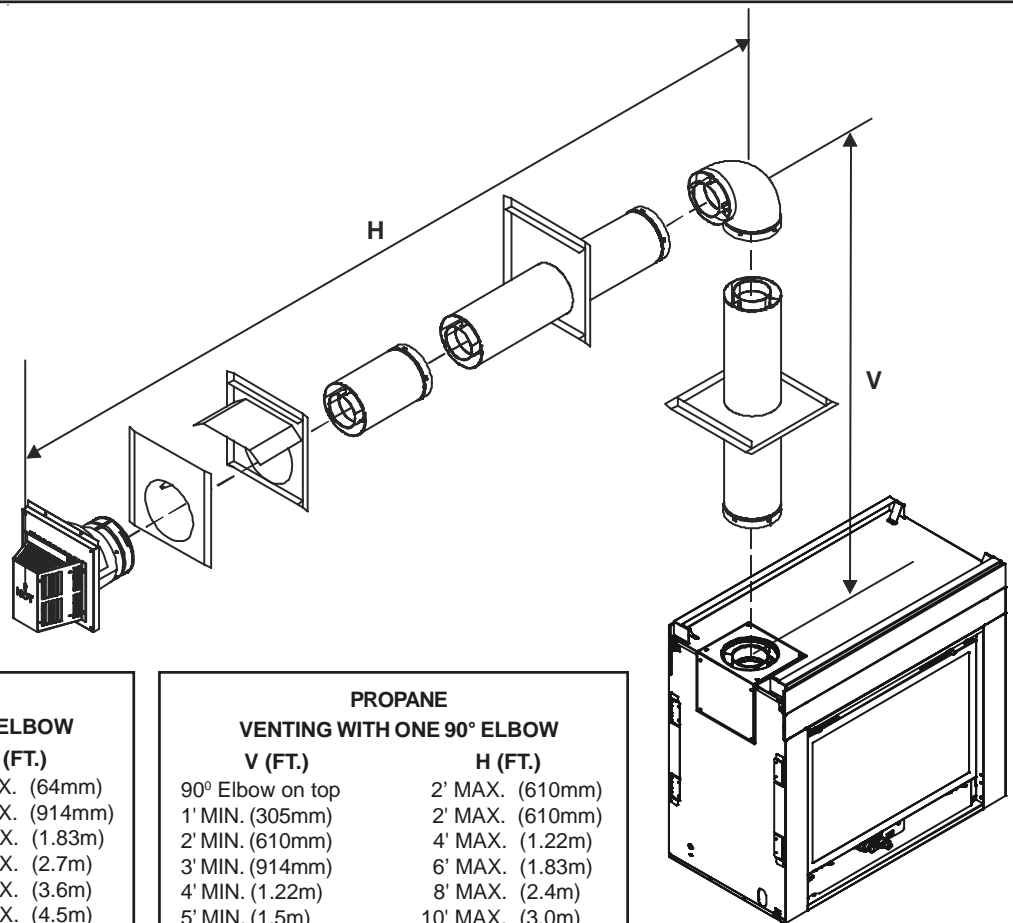

Figure 13. Venting with One 90° Elbow



**NATURAL GAS
VENTING WITH ONE 90° ELBOW**

V (FT.)	H (FT.)
90° Elbow on top	2.5' MAX. (64mm)
1' MIN. (305mm)	3' MAX. (914mm)
2' MIN. (610mm)	6' MAX. (1.83m)
3' MIN. (914mm)	9' MAX. (2.7m)
4' MIN. (1.22m)	12' MAX. (3.6m)
5' MIN. (1.5m)	15' MAX. (4.5m)
6' MIN. (1.83m)	18' MAX. (5.5m)
V + H = 50' MAX. (15.2m)	

**PROPANE
VENTING WITH ONE 90° ELBOW**

V (FT.)	H (FT.)
90° Elbow on top	2' MAX. (610mm)
1' MIN. (305mm)	2' MAX. (610mm)
2' MIN. (610mm)	4' MAX. (1.22m)
3' MIN. (914mm)	6' MAX. (1.83m)
4' MIN. (1.22m)	8' MAX. (2.4m)
5' MIN. (1.5m)	10' MAX. (3.0m)
6' MIN. (1.83m)	12' MAX. (3.6m)
V + H = 50' MAX. (15.2m)	

Figure 14. Venting with One 90° Elbow

NATURAL GAS
VENTING WITH TWO 90° ELBOWS

V (FT.)	H + H ₁ (FT.)
90° Elbow on top	2.5' MAX. (64mm)
1' MIN. (305mm)	3' MAX. (914mm)
2' MIN. (610mm)	6' MAX. (1.83m)
3' MIN. (914mm)	9' MAX. (2.7m)
4' MIN. (1.22m)	12' MAX. (3.6m)
5' MIN. (1.5m)	15' MAX. (4.5m)
6' MIN. (1.83m)	18' MAX. (5.5m)
V + H + H ₁ = 50' MAX. (15.2m)	
H + H ₁ = 18' MAX. (5.5m)	

PROPANE
VENTING WITH TWO 90° ELBOWS

V (FT.)	H + H ₁ (FT.)
90° Elbow on top	2' MAX. (610mm)
1' MIN. (305mm)	2' MAX. (610mm)
2' MIN. (610mm)	4' MAX. (1.22m)
3' MIN. (914mm)	6' MAX. (1.83m)
4' MIN. (1.22m)	8' MAX. (2.4m)
5' MIN. (1.5m)	10' MAX. (3.0m)
6' MIN. (1.83m)	12' MAX. (3.6m)
V + H + H ₁ = 50' MAX. (15.2m)	
H + H ₁ = 12' MAX. (3.6m)	

NATURAL GAS
VENTING WITH TWO 90° ELBOWS

V + V ₁ (FT.)	H (FT.)
90° Elbow on top	2.5' MAX. (64mm)
1' MIN. (305mm)	3' MAX. (914mm)
2' MIN. (610mm)	6' MAX. (1.83m)
3' MIN. (914mm)	9' MAX. (2.7m)
4' MIN. (1.22m)	12' MAX. (3.6m)
5' MIN. (1.5m)	15' MAX. (4.5m)
6' MIN. (1.83m)	18' MAX. (5.5m)
V + V ₁ + H = 50' MAX. (15.2m)	

PROPANE
VENTING WITH TWO 90° ELBOWS

V + V ₁ (FT.)	H (FT.)
90° Elbow on top	2' MAX. (610mm)
1' MIN. (305mm)	2' MAX. (610mm)
2' MIN. (610mm)	4' MAX. (1.22m)
3' MIN. (914mm)	6' MAX. (1.83m)
4' MIN. (1.22m)	8' MAX. (2.4m)
5' MIN. (1.5m)	10' MAX. (3.0m)
6' MIN. (1.83m)	12' MAX. (3.6m)
V + V ₁ + H = 50' MAX. (15.2m)	

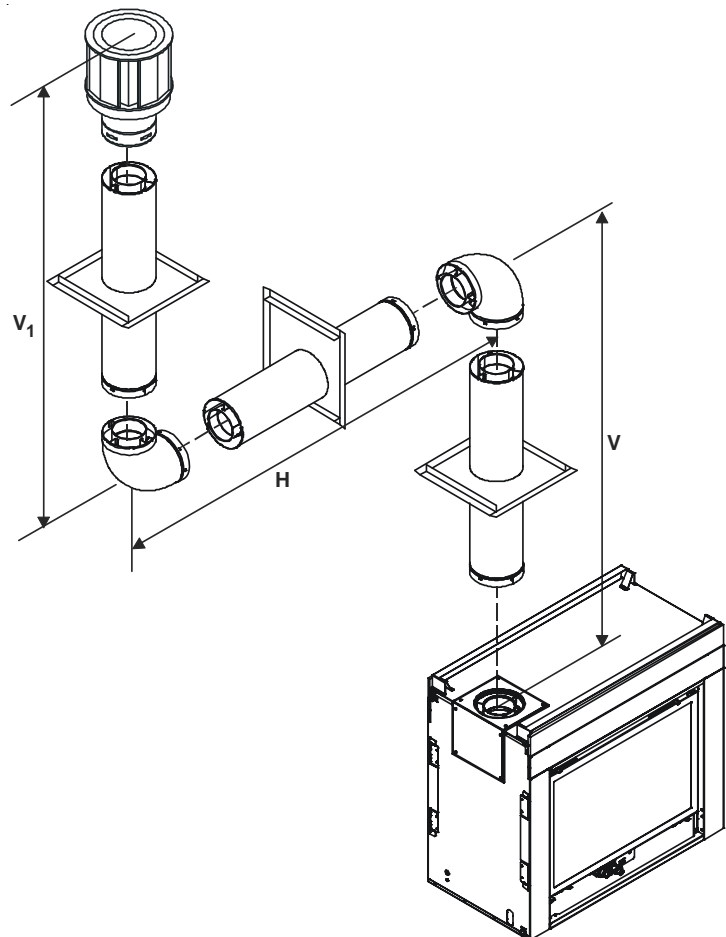
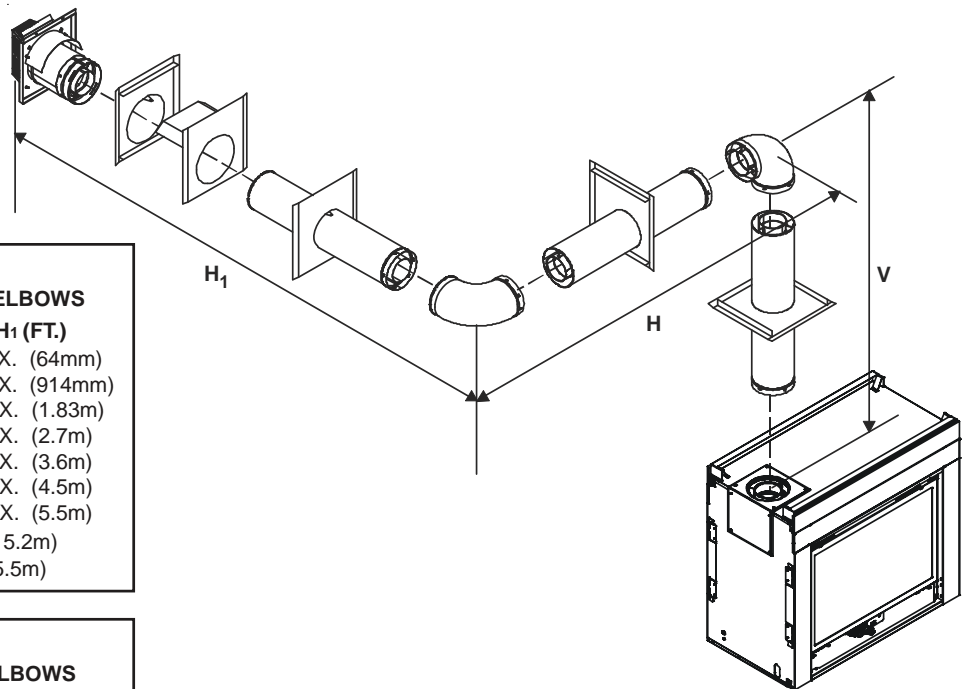

Figure 15. Venting with Two 90° Elbows

NATURAL GAS VENTING WITH TWO 90° ELBOWS	
V (FT.)	H + H ₁ (FT.)
1' MIN. (305mm)	3' MAX. (914mm)
2' MIN. (610mm)	6' MAX. (1.83m)
3' MIN. (914mm)	9' MAX. (2.7m)
4' MIN. (1.22m)	12' MAX. (3.6m)
5' MIN. (1.5m)	15' MAX. (4.5m)
6' MIN. (1.83m)	18' MAX. (5.5m)
V + H + H ₁ = 50' MAX. (15.2m)	
H + H ₁ = 18' MAX. (5.5m)	

PROPANE VENTING WITH TWO 90° ELBOWS	
V (FT.)	H + H ₁ (FT.)
1' MIN. (305mm)	2' MAX. (610mm)
2' MIN. (610mm)	4' MAX. (1.22m)
3' MIN. (914mm)	6' MAX. (1.83m)
4' MIN. (1.22m)	8' MAX. (2.4m)
5' MIN. (1.5m)	10' MAX. (3.0m)
6' MIN. (1.83m)	12' MAX. (3.6m)
V + H + H ₁ = 50' MAX. (15.2m)	
H + H ₁ = 12' MAX. (3.6m)	

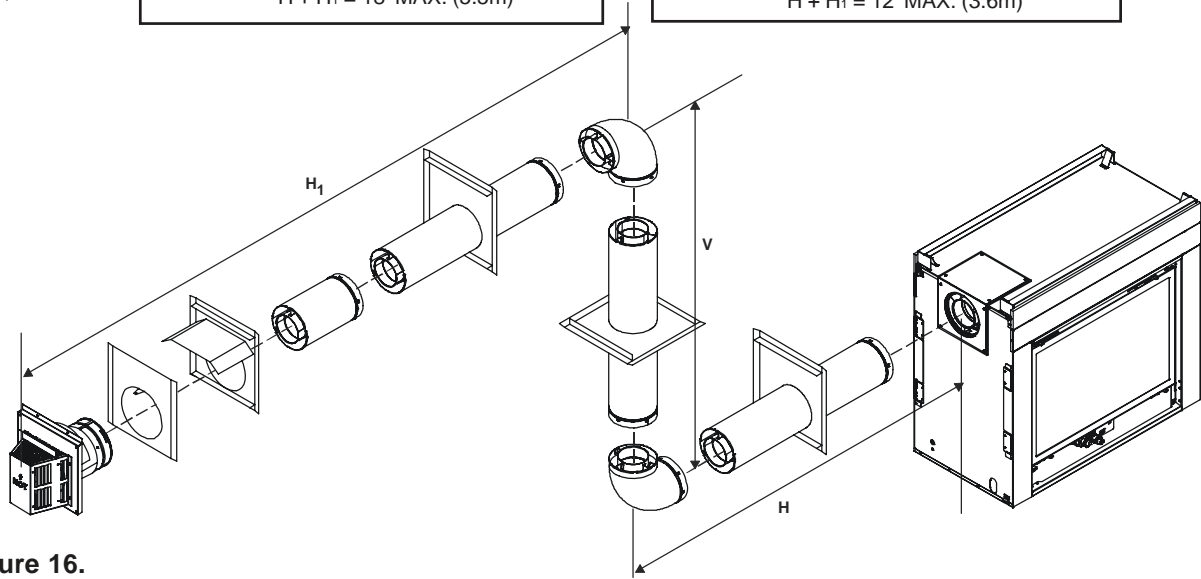
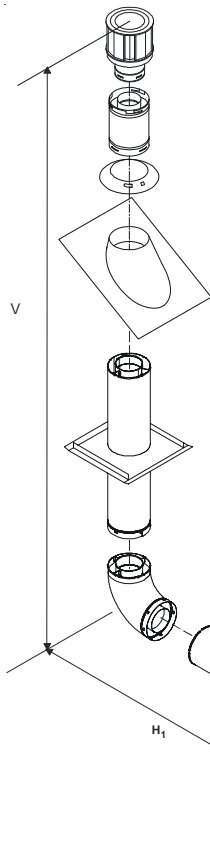

Figure 16.
Venting with Two 90° Elbows



NATURAL GAS VENTING WITH TWO 90° ELBOWS	
V (FT.)	H + H ₁ (FT.)
1' MIN. (305mm)	3' MAX. (914mm)
2' MIN. (610mm)	6' MAX. (1.83m)
3' MIN. (914mm)	9' MAX. (2.7m)
4' MIN. (1.22m)	12' MAX. (3.6m)
5' MIN. (1.5m)	15' MAX. (4.5m)
6' MIN. (1.83m)	18' MAX. (5.5m)
V + H + H ₁ = 50' MAX. (15.2m)	
H + H ₁ = 18' MAX. (5.5m)	

PROPANE VENTING WITH TWO 90° ELBOWS	
V (FT.)	H + H ₁ (FT.)
1' MIN. (305mm)	2' MAX. (610mm)
2' MIN. (610mm)	4' MAX. (1.22m)
3' MIN. (914mm)	6' MAX. (1.83m)
4' MIN. (1.22m)	8' MAX. (2.4m)
5' MIN. (1.5m)	10' MAX. (3.0m)
6' MIN. (1.83m)	12' MAX. (3.6m)
V + H + H ₁ = 50' MAX. (15.2m)	
H + H ₁ = 12' MAX. (3.6m)	

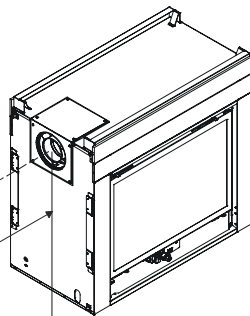

Figure 17. Venting with Two 90° Elbows

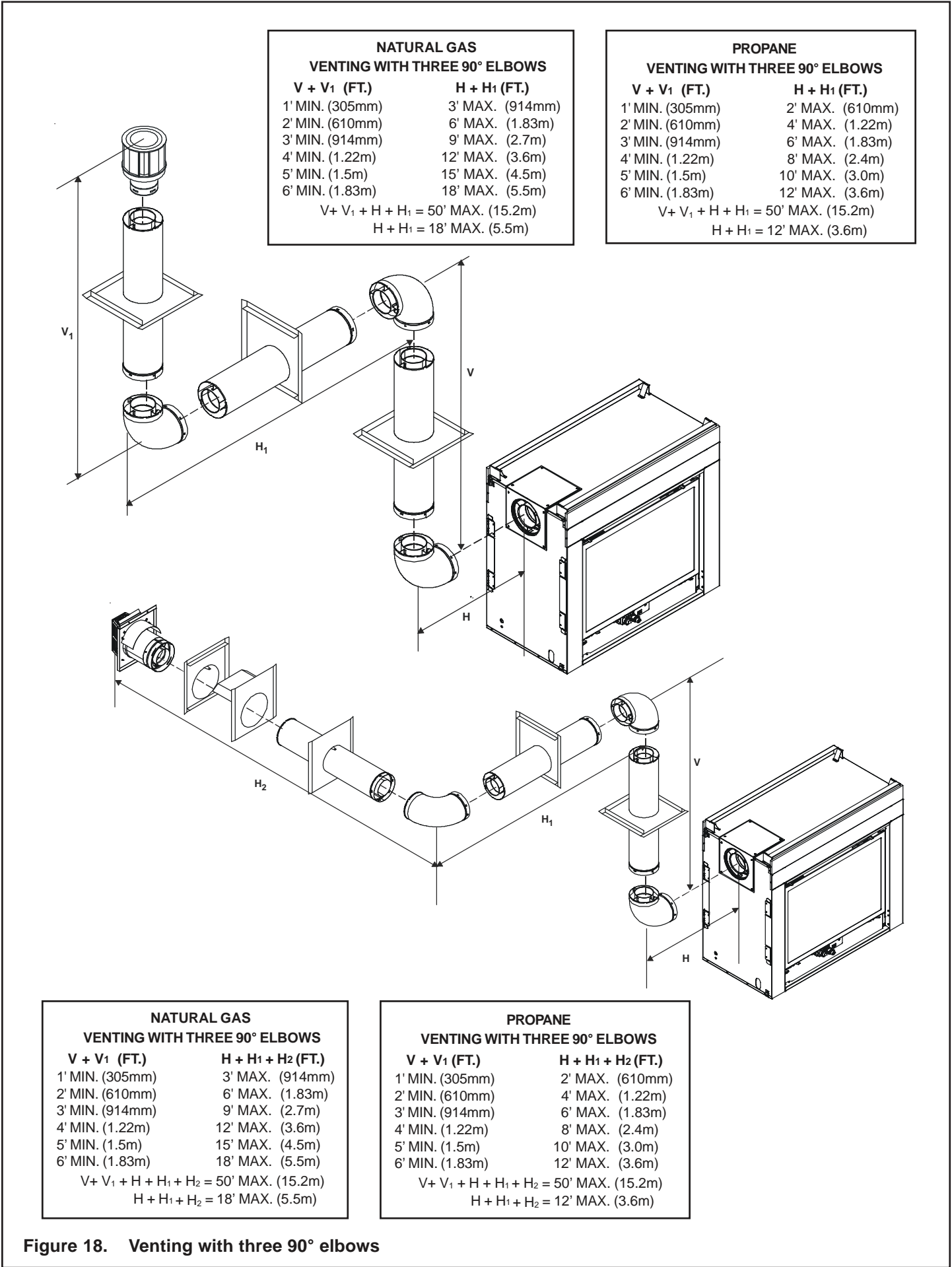
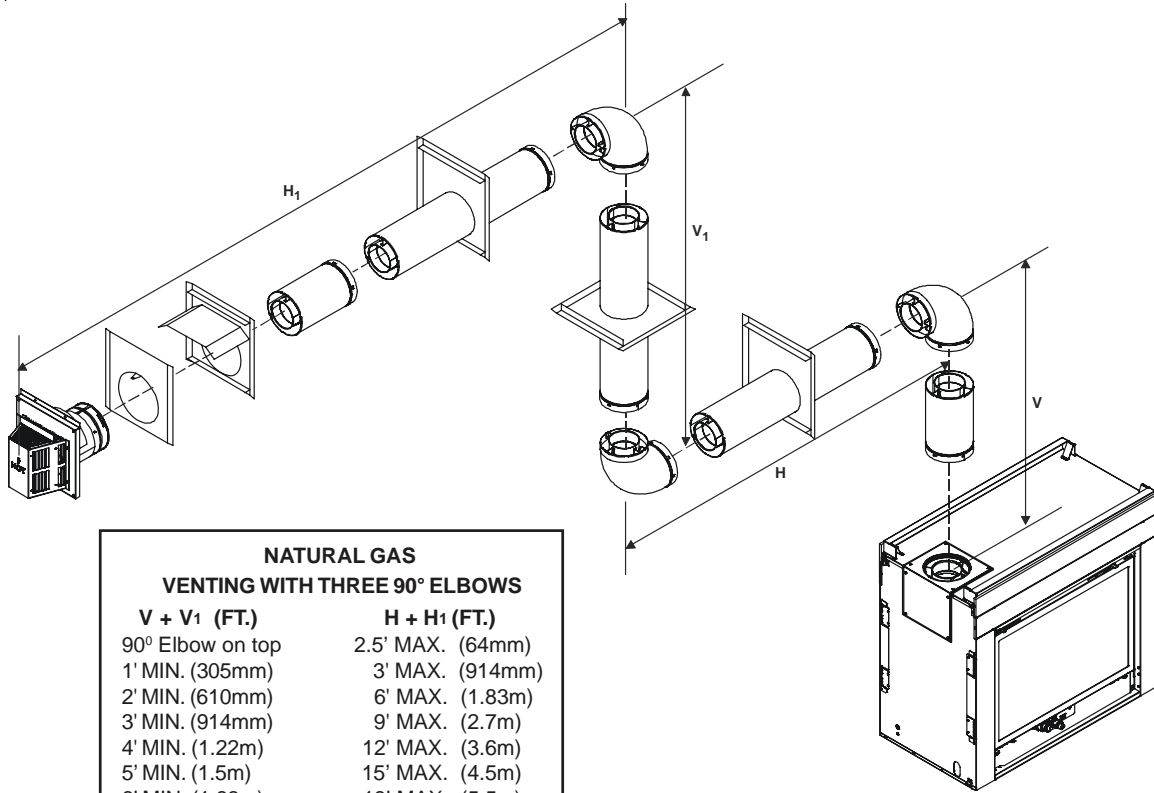

Figure 18. Venting with three 90° elbows



**NATURAL GAS
VENTING WITH THREE 90° ELBOWS**

V + V ₁ (FT.)	H + H ₁ (FT.)
90° Elbow on top	2.5' MAX. (64mm)
1' MIN. (305mm)	3' MAX. (914mm)
2' MIN. (610mm)	6' MAX. (1.83m)
3' MIN. (914mm)	9' MAX. (2.7m)
4' MIN. (1.22m)	12' MAX. (3.6m)
5' MIN. (1.5m)	15' MAX. (4.5m)
6' MIN. (1.83m)	18' MAX. (5.5m)
V + V ₁ + H + H ₁ = 50' MAX. (15.2m)	
H + H ₁ = 18' MAX. (5.5m)	

**PROPANE
VENTING WITH THREE 90° ELBOWS**

V + V ₁ (FT.)	H + H ₁ (FT.)
90° Elbow on top	2' MAX. (610mm)
1' MIN. (305mm)	2' MAX. (610mm)
2' MIN. (610mm)	4' MAX. (1.22m)
3' MIN. (914mm)	6' MAX. (1.83m)
4' MIN. (1.22m)	8' MAX. (2.4m)
5' MIN. (1.5m)	10' MAX. (3.0m)
6' MIN. (1.83m)	12' MAX. (3.6m)
V + V ₁ + H + H ₁ = 50' MAX. (15.2m)	
H + H ₁ = 12' MAX. (3.6m)	

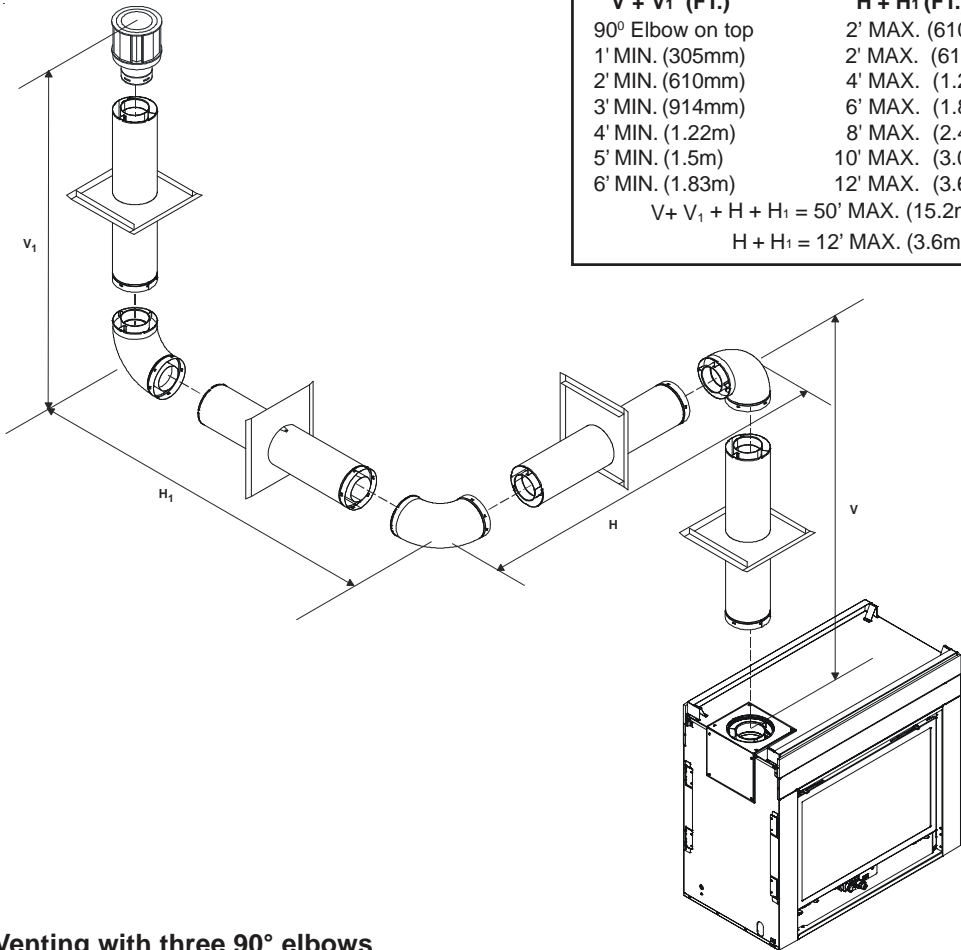

Figure 19. Venting with three 90° elbows

B. Installing Vent Components

After determining which direction the 45° elbow will be used follow venting instructions accordingly.

- • This fireplace comes ready to vent vertically.
- • To vent off the unit horizontally, the elbow cover plate must first be removed from the unit (see Figure 20).
- The elbow can be removed from the unit by aligning the seams of the elbow to the arrows on the surrounding heat shield (see Figure 21).
- Position the elbow in the vertical position. Snap in place with the starting collar.
- Replace the elbow cover plate aligning it with the elbow and secure in place with the 8 screws.
- Place the rope ring around the first section of pipe and slide it up against the cover plate.

NOTE: The rope ring is needed for the heat management and to prevent cold air infiltration.

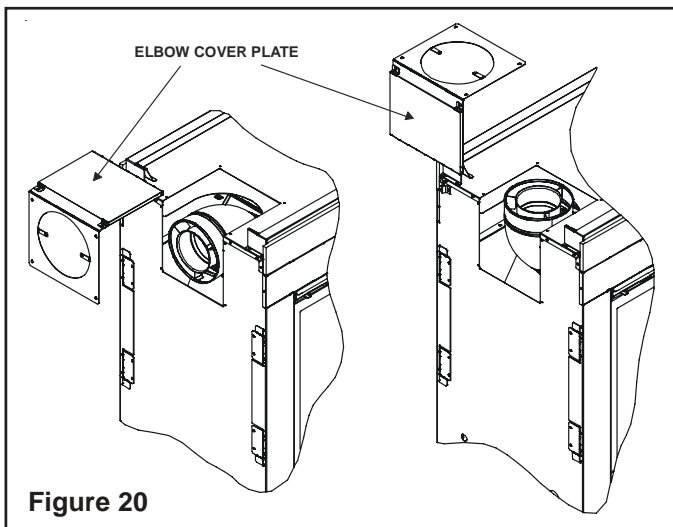

Figure 20

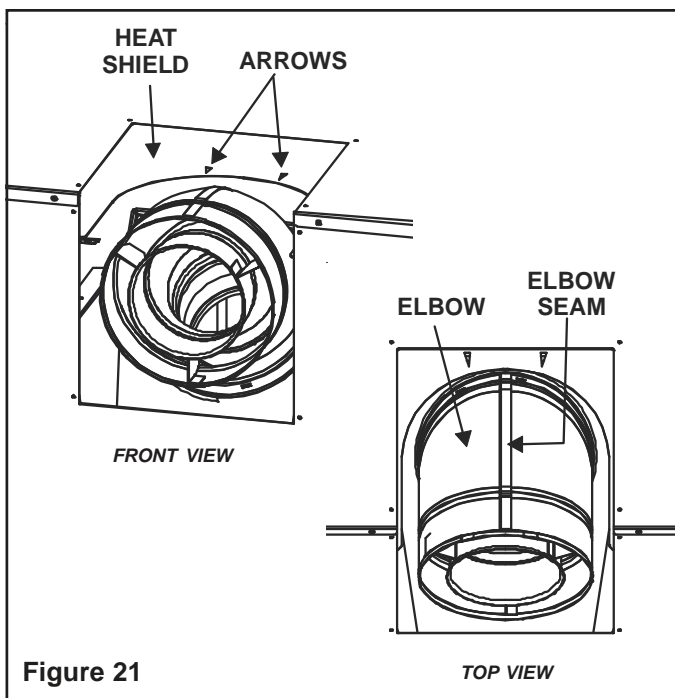

Figure 21

Venting Out Vertically

If the vertical vent component is over 4 feet, you may want to install the flue restrictor (located in the bag containing the install manual) to improve flame appearance. Center the flue restrictor on the 5" flue being used, and with self tapping screws secure the restrictor to the inside of the firebox as shown in Figure 22.

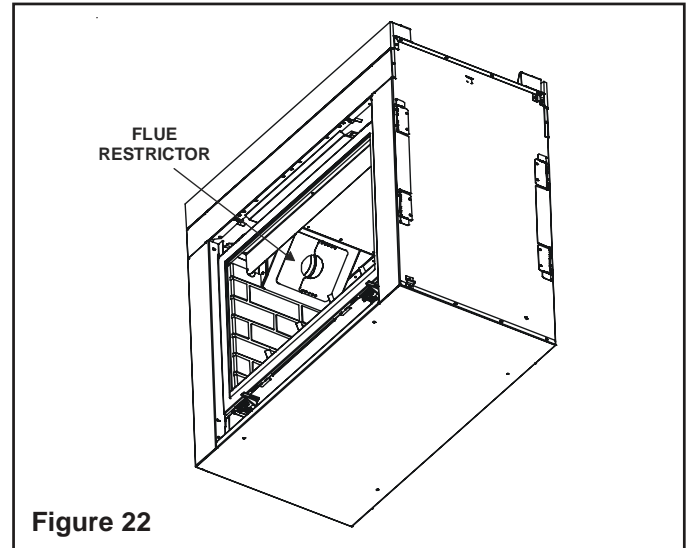

Figure 22

1. Attach the First Vent Component to the Starting Collars

To attach the first vent component to the starting collars of the fireplace:

- Slide the first vent section onto the unit and push in until they snap lock in position.
- Rotate this section to the desired position.
- Using the two tabs provided on the elbow cover plate, secure the first section of venting to the fireplace with two screws.

Refer to Cinch Pipe and Termination Cap installation instructions.

If the installation is for a termination cap attached directly to the fireplace, skip to the sections, **Install Firestops and Vent Termination.**

2. Continue Adding Vent Components

Refer to Cinch Pipe and Termination Cap installation instructions.

- Continue adding vent components, locking each succeeding component into place.
- Ensure that each succeeding vent component is securely fitted and locked into the preceding component in the vent system. Securing pipe sections with a maximum of two screws is recommended.
- 90° elbows may be installed and rotated to any point around the preceding component's vertical axis. If an elbow does not end up in a locked position with the preceding component, attach with a minimum of two (2) sheet metal screws.

3. Install Support Brackets

Refer to Cinch Pipe and Termination Cap installation instructions.

4. Install Firestops

For Horizontal Runs - Firestops are **REQUIRED** on both sides of a combustible wall through which the vent passes.

NOTE: Model DVP-TRAP does not need an exterior firestop on an exterior combustible wall. The firestop is built into the cap.

To install firestops for horizontal runs that pass through either interior or exterior walls:

- Cut a 10" x 12" (254mm X 305mm) hole through the wall.
- **NOTE: The center of the hole is one (1) inch (25.4mm) above the center of the horizontal vent pipe.**
- Position the firestops on both sides of the hole previously cut and secure the firestops with nails or screws.
- The heat shields of the firestops **MUST BE** placed towards the top of the hole.
- Continue the vent run through the firestops.

NOTE: There must be NO INSULATION or other combustibles inside the framed firestop opening.

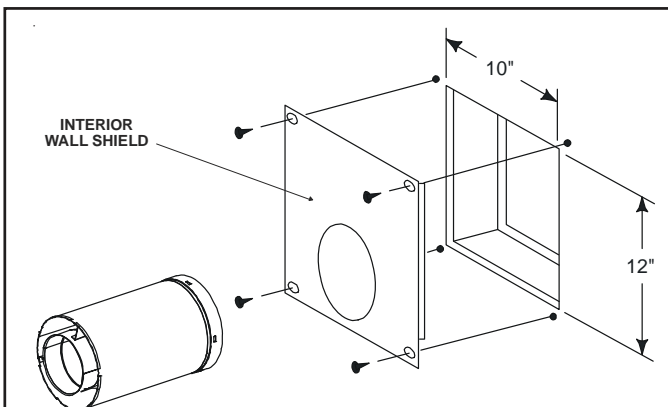
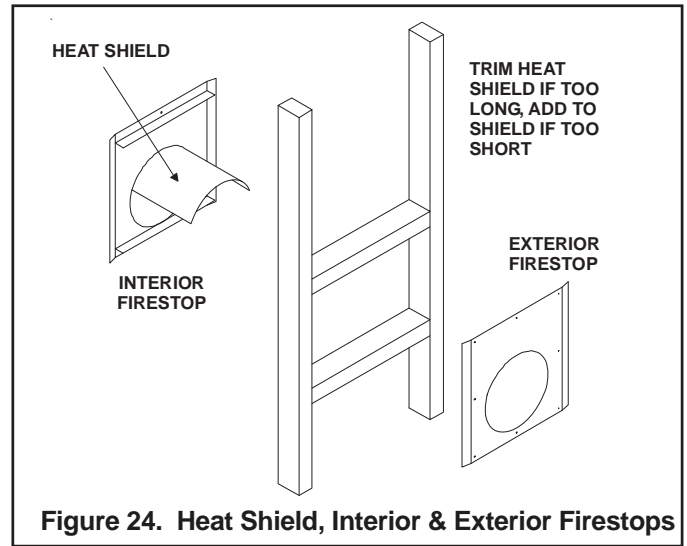

Figure 23. 10" x 12" Hole and Vent Pipe



For Vertical Runs - One ceiling firestop is **REQUIRED** at the hole in each ceiling through which the vent passes.

To install firestops for vertical runs that pass through ceilings:

- Position a plumb bob directly over the center of the vertical vent component.
- Mark the ceiling to establish the centerpoint of the vent.
- Drill a hole or drive a nail through this centerpoint.
- Check the floor above for any obstructions, such as wiring or plumbing runs.
- Reposition the fireplace and vent system, if necessary, to accommodate the ceiling joists and/or obstructions.
- Cut an 10-inch X 10-inch (254mm x 254mm) hole through the ceiling, using the centerpoint previously marked.
- Frame the hole with framing lumber the same size as the ceiling joists.

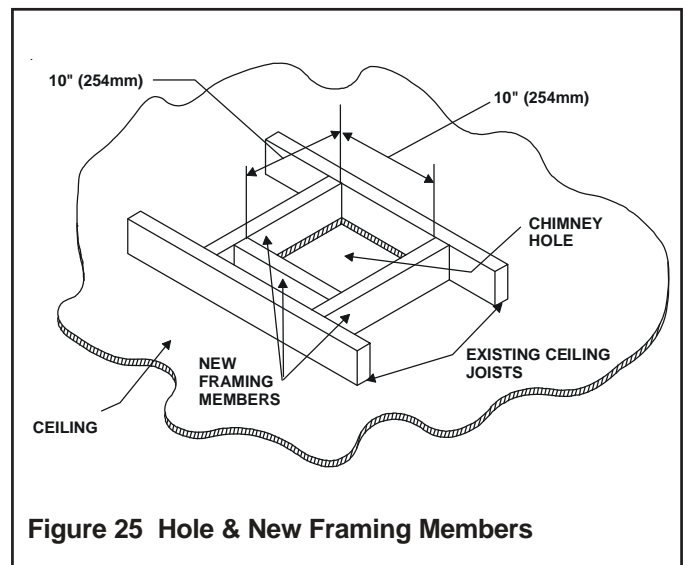
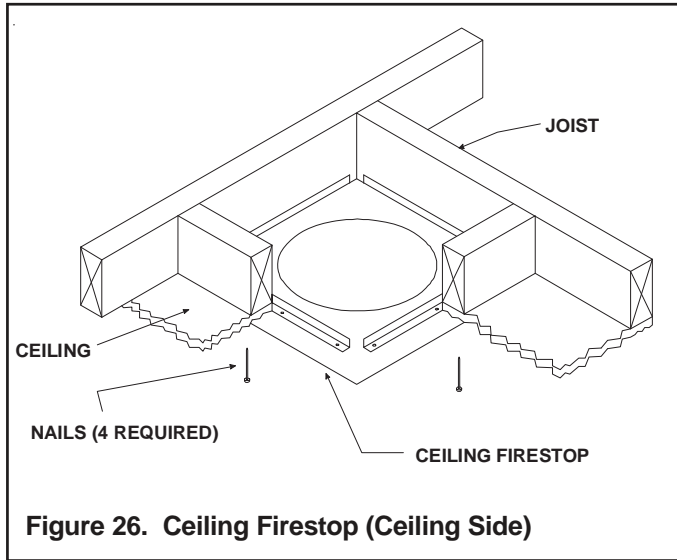

Figure 25 Hole & New Framing Members

If the area above the ceiling is **NOT** an attic, position and secure the ceiling firestop on the ceiling side of the previously cut and framed hole.



If the area above the ceiling **IS** an attic, position and secure the firestop on top of the previously framed hole.
NOTE: Keep insulation away from the vent pipe at least 1 inch (25mm).

NOTE: There must be **NO INSULATION** or other combustibles inside the framed firestop opening.

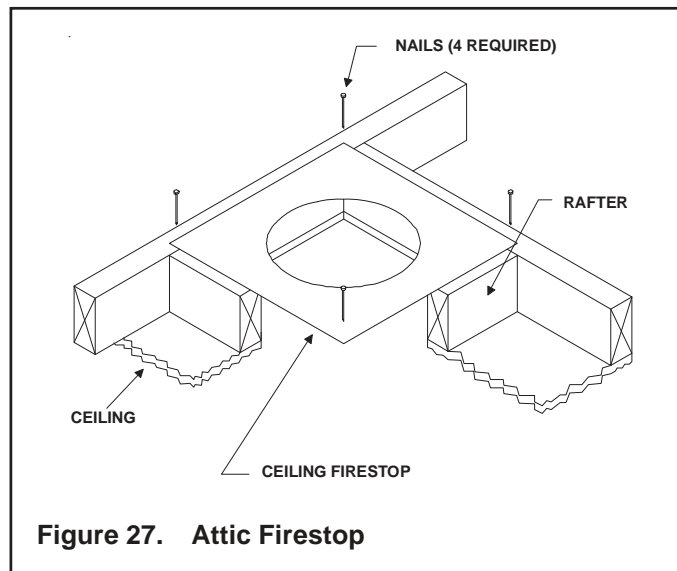

C. Vent Termination

For Horizontal Terminations - To attach and secure the termination to the last section of horizontal vent refer to the Cinch Pipe and Termination Cap installation instructions.

- Push on and snap lock as described at the beginning of the Installing Vent Components section.
- The termination kit should pass through the wall firestops from the exterior of the building.
- Adjust the termination cap to its final exterior position on the building and interlock the flue sections.

WARNING: THE TERMINATION CAP MUST BE POSITIONED SO THAT THE ARROW IS POINTING UP.

For trapezoidal cap termination kits:

- Using screws secure the cap to the exterior wall through the flanges in the cap.

WARNING: VENTING TERMINALS SHALL NOT BE RECESSED INTO A WALL OR SIDING. VENT TERMINATION CLEARANCES MUST BE FOLLOWED TO AVOID FIRE DANGER. SEE VENT TERMINATION MINIMUM CLEARANCES DIAGRAM ON FOLLOWING PAGE.

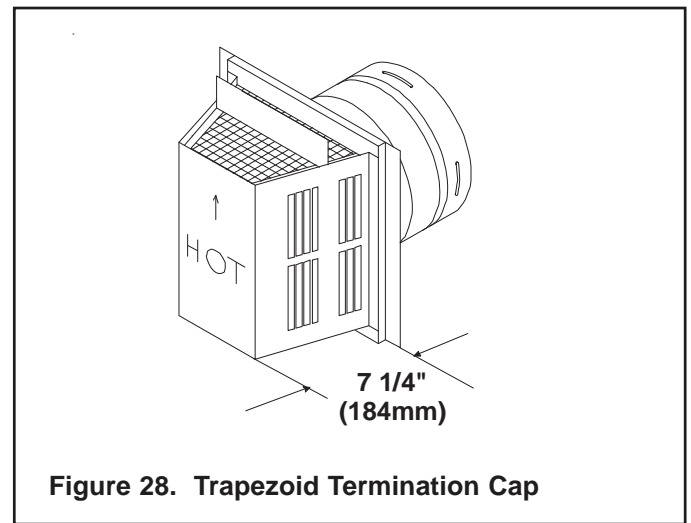

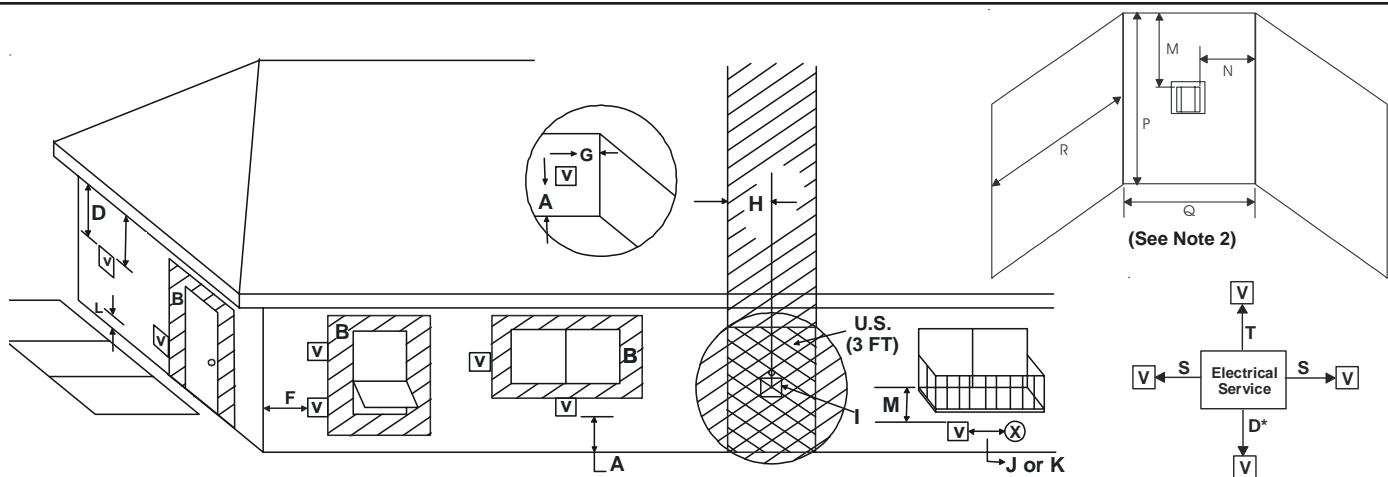

V = VENT TERMINAL **X** = AIR SUPPLY INLET **[Hatched]** = AREA WHERE TERMINAL IS NOT PERMITTED

- A = 12" clearances above grade, veranda, porch, deck or balcony
(See Note 1)
- B = 12" clearances to window or door that may be opened, or to permanently closed window.
- D* = 18" vertical clearance to unventilated soffit or to ventilated soffit located above the terminal
*36" for vinyl clad soffits and below electrical service
- F = 9" clearance to outside corner
- G = 6" clearance to inside corner
- H = 3 ft. (Canada) not to be installed above a gas meter/regulator assembly within 3 feet (90cm) horizontally from the center-line of the regulator
- I = 3 ft. (U.S.A.)
6 ft. (Canada) clearance to gas service regulator vent outlet
- J = 9" (U.S.A.)
12" (Canada) clearance to non-mechanical air supply inlet to building or the combustion air inlet to any other appliance

- K = 3 ft. (U.S.A.)
6 ft. (Canada) clearance to a mechanical air supply inlet
- L** = 7 ft. clearance above paved sidewalk or a paved driveway located on **public** property
(See Note 1)
- M*** = 18" clearance under veranda, porch, deck, balcony or overhang
36" vinyl
- N = 6" non-vinyl sidewalls
12" vinyl sidewalls
- P = 8 ft.

	Q _{MIN}	R _{MAX}
1 cap	3 feet	2 x Q _{ACTUAL}
2 caps	6 feet	1 x Q _{ACTUAL}
3 caps	9 feet	2/3 x Q _{ACTUAL}
4 caps	12 feet	1/2 x Q _{ACTUAL}
Q _{MIN} = # termination caps x 3		R _{MAX} = (2 / # termination caps) x Q _{ACTUAL}

- S = 6" clearance from sides of electrical service
(See Note 5)
- T = 12" clearance above electrical service
(See Note 5)

** a vent shall not terminate directly above a sidewalk or paved driveway which is located between two single family dwellings and serves both dwellings.

*** only permitted if veranda, porch, deck or balcony is fully open on a minimum of 2 sides beneath the floor, or meets Note 2.

NOTE 1: On private property where termination is less than 7 feet above a sidewalk, driveway, deck, porch, veranda or balcony, use of a listed cap shield is suggested.

NOTE 2: Termination in an alcove space (spaces open only on one side and with an overhang) are permitted with the dimensions specified for vinyl or non-vinyl siding and soffits. **1.** There must be 3 feet minimum between termination caps. **2.** All mechanical air intakes within 10 feet of a termination cap must be a minimum of 3 feet below the termination cap. **3.** All gravity air intakes within 3 feet of a termination cap must be a minimum of 1 foot below the termination cap.

NOTE 3: Local codes or regulations may require different clearances.

NOTE 4: Termination caps may be hot. Consider their proximity to doors or other traffic areas.

NOTE 5: Location of the vent termination must not interfere with access to the electrical service.

WARNING: In the U.S: Vent system termination is **NOT** permitted in screened porches. You must follow side wall, overhang and ground clearances as stated in the instructions.

In Canada: Vent system termination is **NOT** permitted in screened porches. Vent system termination is permitted in porch areas with two or more sides open. You must follow all side walls, overhang and ground clearances as stated in the instructions.

Heat & Glo assumes no responsibility for the improper performance of the fireplace when the venting system does not meet these requirements.

Figure 29. Vent Termination Minimum Clearances

CAUTION: IF EXTERIOR WALLS ARE FINISHED WITH VINYL SIDING, IT IS SUGGESTED THAT A VINYL PROTECTOR KIT BE INSTALLED.

For Vertical Terminations - To locate the vent and install the vent sections:

- Locate and mark the vent centerpoint on the underside of the roof, and drive a nail through the centerpoint.
- Make the outline of the roof hole around the centerpoint nail.
- The size of the roof hole framing dimensions depend on the pitch of the roof. There **MUST BE** a 1-inch (25.4mm) clearance from the vertical vent pipe to combustible materials.
- Mark the roof hole accordingly.
- Cover the opening of the installed vent pipes.
- Cut and frame the roof hole.
- Use framing lumber the same size as the roof rafters and install the frame securely. Flashing anchored to the frame must withstand heavy winds.
- Continue to install concentric vent sections up through the roof hole (for inside vent installations) or up past the roof line until you reach the appropriate distance above the roof (for outside terminations).

WARNING: MAJOR U.S. BUILDING CODES SPECIFY MINIMUM CHIMNEY AND/OR VENT HEIGHT ABOVE THE ROOF TOP. THESE MINIMUM HEIGHTS ARE NECESSARY IN THE INTEREST OF SAFETY. SEE THE FOLLOWING DIAGRAM FOR MINIMUM HEIGHTS, PROVIDED THE TERMINATION CAP IS AT LEAST 20 INCHES FROM A VERTICAL WALL AND 2-FEET BELOW A HORIZONTAL OVERHANG.

NOTE: This also pertains to vertical vent systems installed on the outside of the building.

To seal the roof hole, and to divert rain and snow from the vent system:

- Attach a flashing to the roof using nails, and use a non-hardening mastic around the edges of the flashing base where it meets the roof.
- Attach a storm collar over the flashing joint to form a water-tight seal. Place non-hardening mastic around the joint, between the storm collar and the vertical pipe.
- Slide the termination cap over the end of the vent pipe and snap into place.

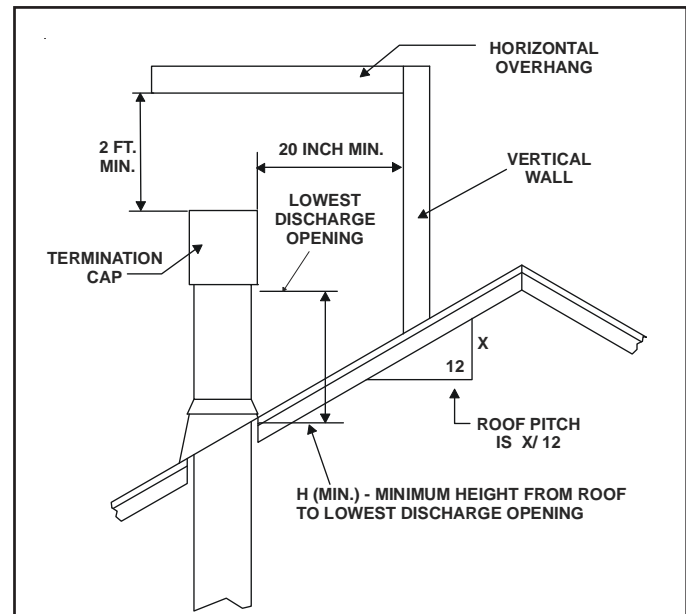

Roof Pitch	H (min.) ft.
flat to 6/12	1.0
over 6/12 to 7/12	1.25
over 7/12 to 8/12	1.5
over 8/12 to 9/12	2.0
over 9/12 to 10/12	2.5
over 10/12 to 11/12	3.25
over 11/12 to 12/12	4.0
over 12/12 to 14/12	5.0
over 14/12 to 16/12	6.0
over 16/12 to 18/12	7.0
over 18/12 to 20/12	7.5
over 20/12 to 21/12	8.0

Figure 30. Minimum Height from Roof to Lowest Discharge Opening

Step 4. Positioning, Leveling, and Securing the Fireplace

The diagram below shows how to properly position, level, and secure the fireplace.

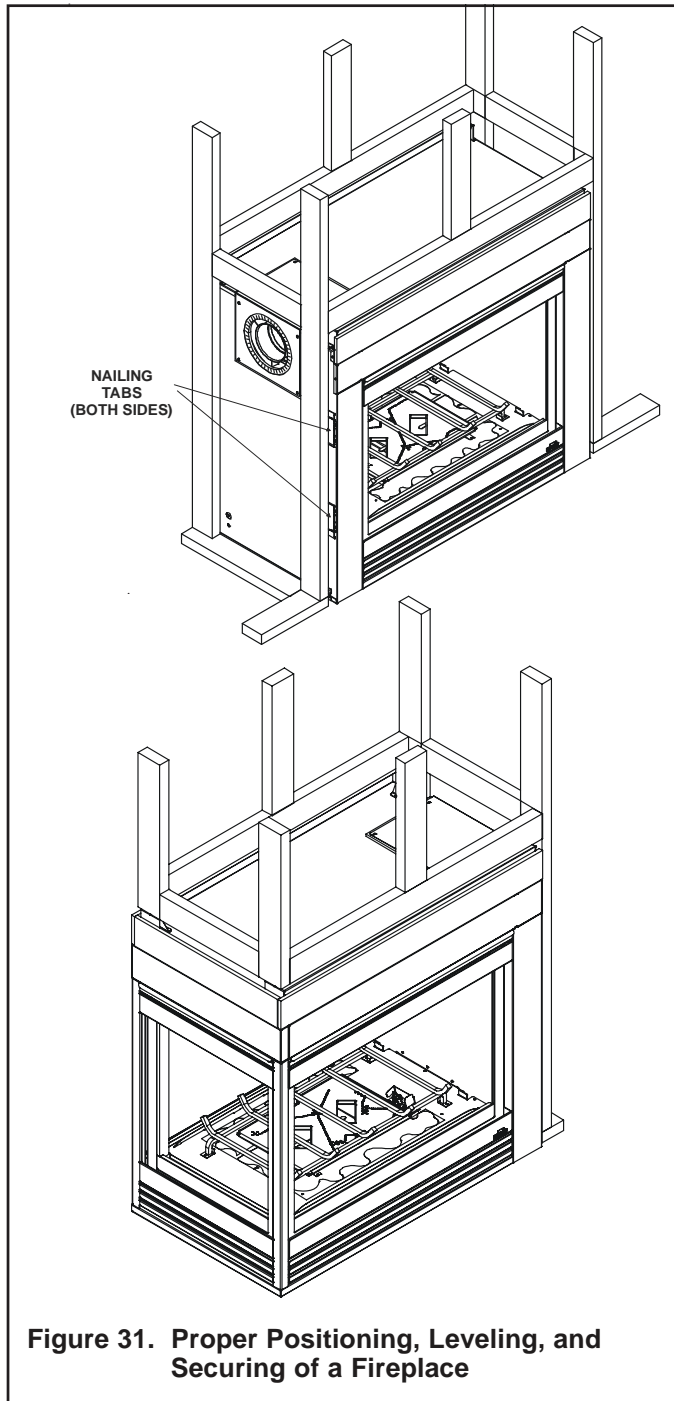

Step 5. The Gas Control System



WARNING: THIS UNIT IS NOT FOR USE WITH SOLID FUEL.

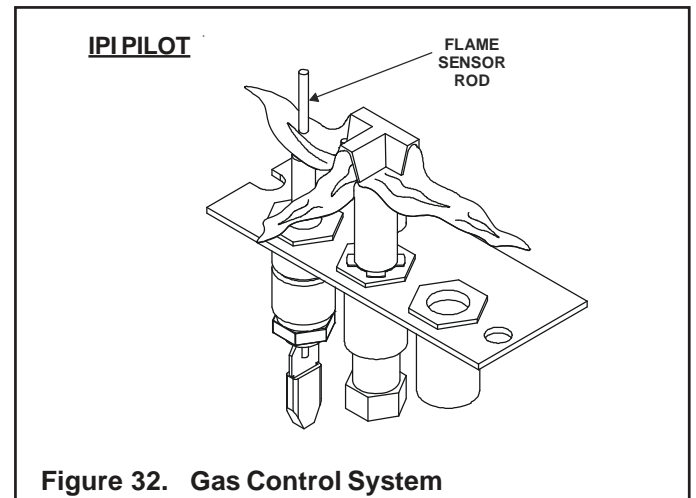

Intermittent Pilot Ignition (IPI) System

This system includes a 3V control valve, electronic module and intermittent pilot.



WARNING: CONTINUOUS 110-120 VAC SERVICE MUST BE WIRED DIRECTLY TO THE FIREPLACE JUNCTION BOX IN A IPI SYSTEM.

- Place the fireplace into position.
- Level the fireplace from side to side and from front to back.
- Shim the fireplace with non-combustible material, such as sheet metal, as necessary.
- Secure the fireplace to the framing by nailing or screwing.
- Holes are provided in the base pan for securing the unit to the floor.

Step 6. The Gas Supply Line

NOTE: Have the gas supply line installed in accordance with local building codes by a qualified installer approved and/or licensed as required by the locality. (In the Commonwealth of Massachusetts installation must be performed by a licensed plumber or gas fitter).

NOTE: Before the first firing of the fireplace, the gas supply line should be purged of any trapped air.

NOTE: Consult local building codes to properly size the gas supply line leading to the 1/2 inch (13 mm) hook-up at the unit.

This gas fireplace is designed to accept a 1/2 inch (13 mm) gas supply line. To install the gas supply line:

- A listed (and Commonwealth of Massachusetts approved) 1/2 inch (13mm) tee-handle manual shut-off valve and a listed flexible gas connector are connected to the 1/2 inch (13mm) inlet of the control valve. **NOTE:** If substituting for these components, please consult local codes for compliance.
- Locate the gas line access hole in the outer casing of the fireplace.
- The gas line may be run from either side of the fireplace provided the hole in the outer wrap does not exceed 2" in diameter and it does not penetrate the actual firebox.
- Open the fireplace lower grille, insert the gas supply line through the gas line hole, and connect it to the shut-off valve.
- When attaching the pipe, support the control so that the lines are not bent or torn.
- After the gas line installation is complete, all connections must be tightened and checked for leaks with a commercially-available, non-corrosive leak check solution. Be sure to rinse off all leak check solution following testing.



WARNING: DO NOT USE AN OPEN FLAME TO CHECK FOR GAS LEAKS.

- Insert insulation from the outside of the fireplace and pack the insulation tightly to totally seal between the pipe and the outer casing.
- At the gas line access hole the gap between the supply piping and gas access hole can be plugged with non-combustible insulation to prevent cold air infiltration.

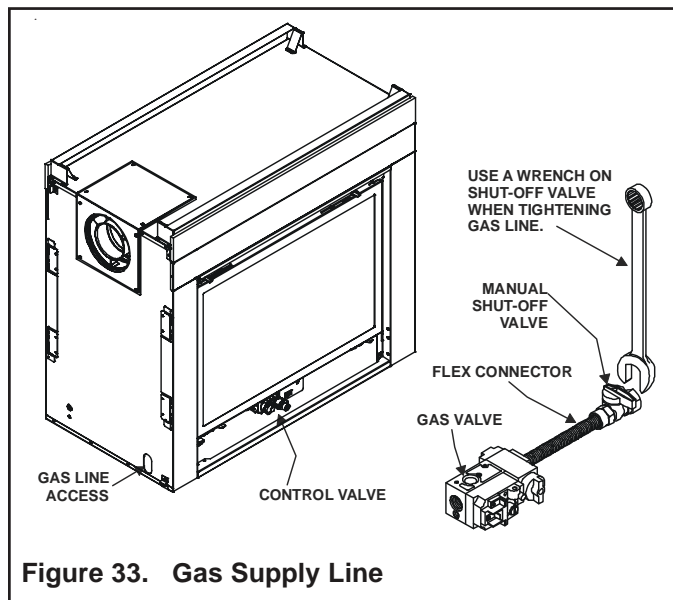

Figure 33. Gas Supply Line

Step 7. Gas Pressure Requirements

Pressure requirements for Heat & Glo gas fireplaces are shown in the table below.

Pressure	Natural Gas	Propane
Minimum Inlet Pressure	5.0 inches w.c.	11.0 inches w.c.
Maximum Inlet Gas Pressure	14.0 inches w.c.	14.0 inches w.c.
Manifold Pressure	3.5 inches w.c.	10.0 inches w.c.

A one-eighth (1/8) inch (3 mm) N.P.T. plugged tapping is provided on the inlet and outlet side of the gas control for a test gauge connection to measure the manifold pressure.

The fireplace and its individual shut-off valve must be disconnected from the gas supply piping system during any pressure testing of the system at test pressures in excess of one-half (1/2) psig (3.5 kPa).

The fireplace must be isolated from the gas supply piping system by closing its individual shut-off valve during any pressure testing of the gas supply piping system at test pressures equal to or less than one-half (1/2) psig (3.5 kPa).

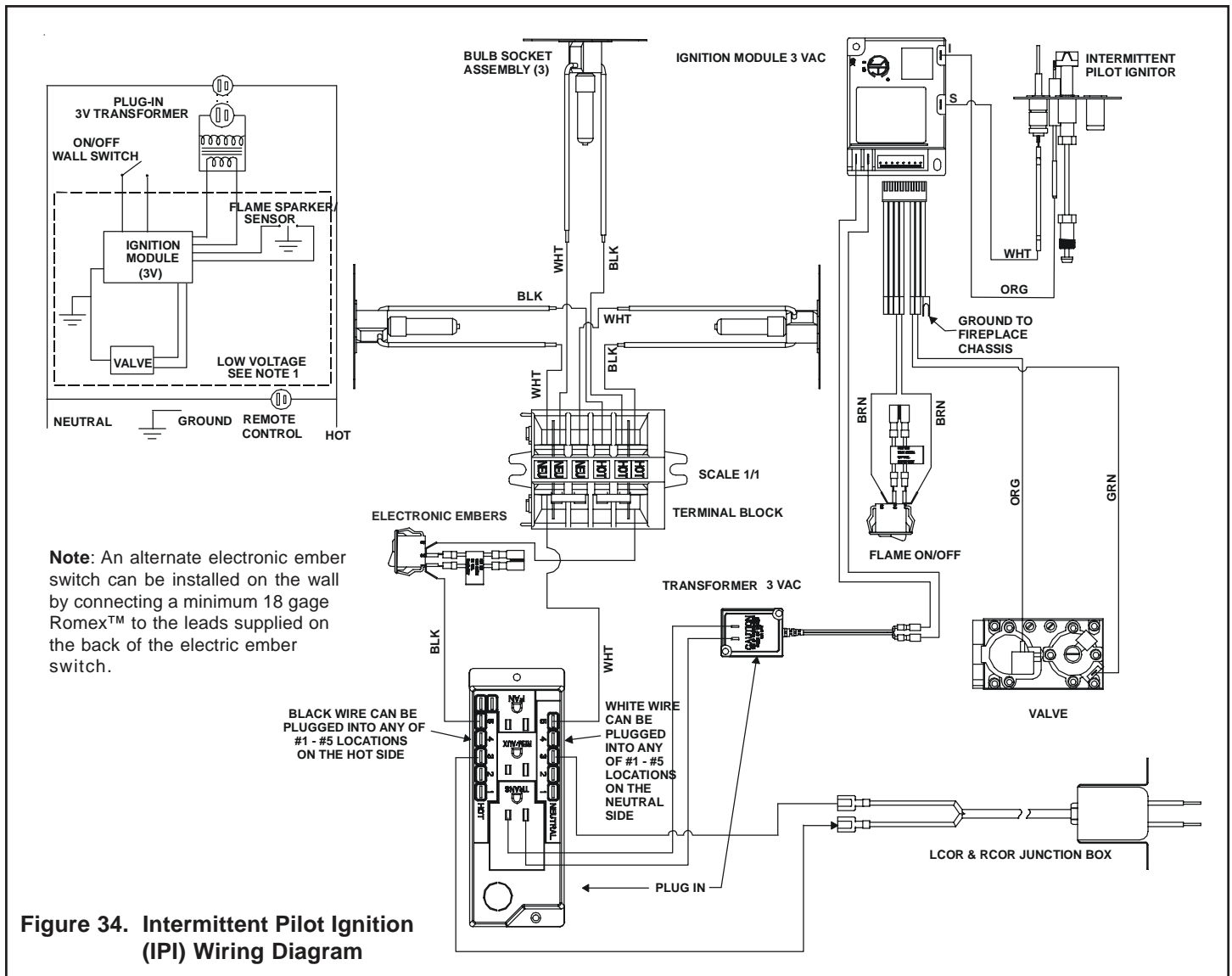

Step 8. Wiring the Fireplace

NOTE: Electrical wiring must be installed by a licensed electrician.

CAUTION: DISCONNECT REMOTE CONTROLS IF ABSENT FOR EXTENDED TIME PERIODS. THIS WILL PREVENT ACCIDENTAL FIREPLACE OPERATION.

For Intermittent Pilot Ignition Wiring

Appliance Requirements

This appliance requires that 110-120 VAC be wired to the junction box. Maintain correct polarity when wiring the junction box.

Operation using Battery Power

This fireplace has an optional battery operation. The system is fully functional with the use of two “D” size batteries without ordinary 110-120 VAC power.

Wiring to the battery pack should be left disconnected in order to conserve battery life. In the case of a loss of power, simply connect red and black wire leads to activate battery power (connect red to red, black to black). The fireplace can be used as necessary. Once power (110 VAC) is restored, disconnect red and black wire leads to extend battery life.

WARNING

Wire 110V to electrical junction box.
Do NOT wire 110V to valve.
Do NOT wire 110V to wall switch.

- Incorrect wiring will damage millivolt valves.
- Uninterrupted or continuous power is required at all times in IPI system EXCEPT when using battery back-up.
- Incorrect wiring will override IPI safety lockout and may cause explosion.

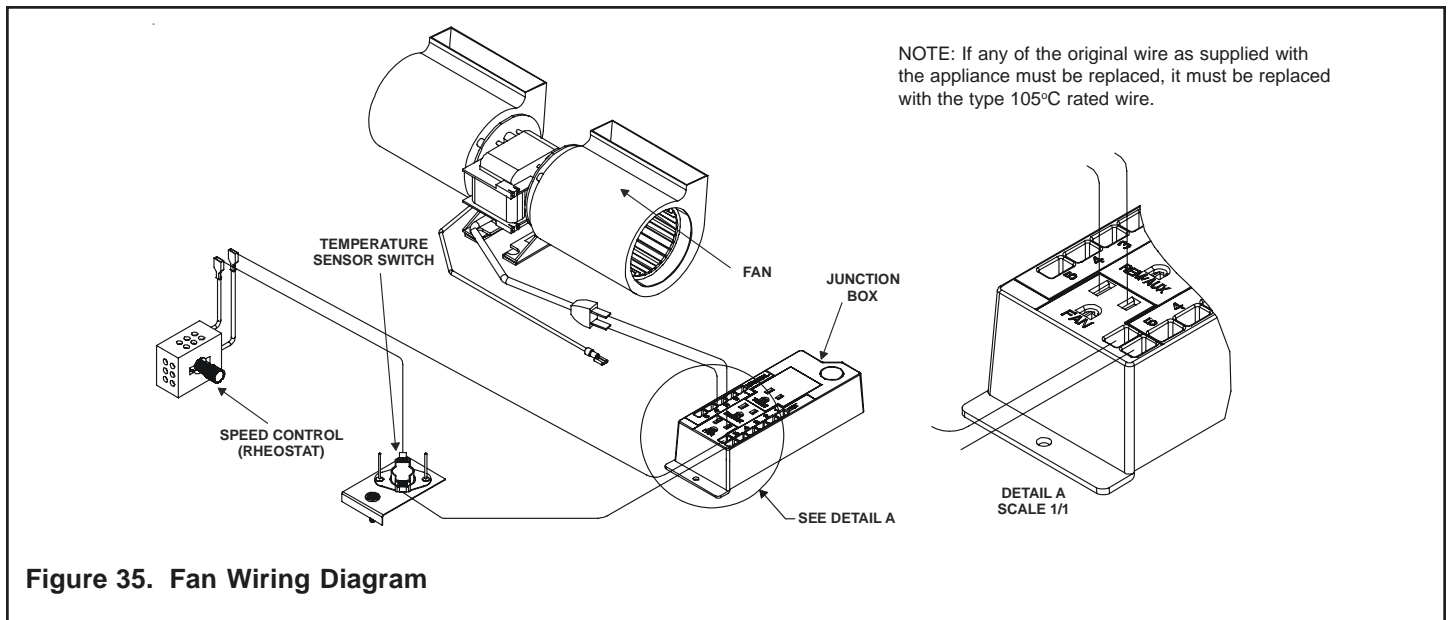

Optional Accessories

Optional fan and remote control kits require that 110-120 VAC be wired to the factory installed junction box before the fireplace is permanently installed.

Fan Installation

Recommended fan locations for the type of fireplace you have (see Figures 36 and 37).

Wall Switch

Position the wall switch in the desired position on a wall. Run a maximum of 25 feet (7.8 m) or less length of 18 A.W.G. minimum wire and connect it to the fireplace ON/OFF switch pigtail.

CAUTION: LABEL ALL WIRES PRIOR TO DISCONNECTION WHEN SERVICING CONTROLS. WIRING ERRORS CAN CAUSE IMPROPER AND DANGEROUS OPERATION. VERIFY PROPER OPERATION AFTER SERVICING.

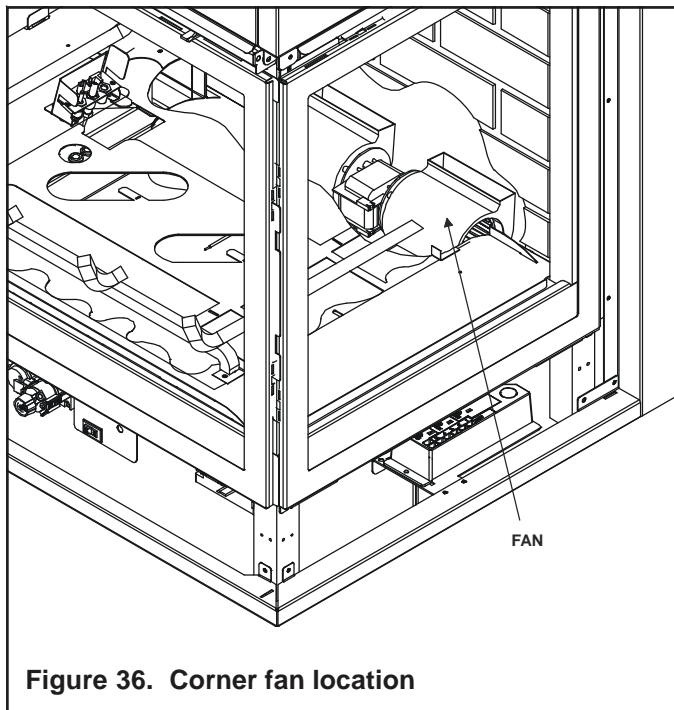

Corner fan location

It is recommended to position the fan in this location as shown. This will provide the best air flow (see Figure 36).

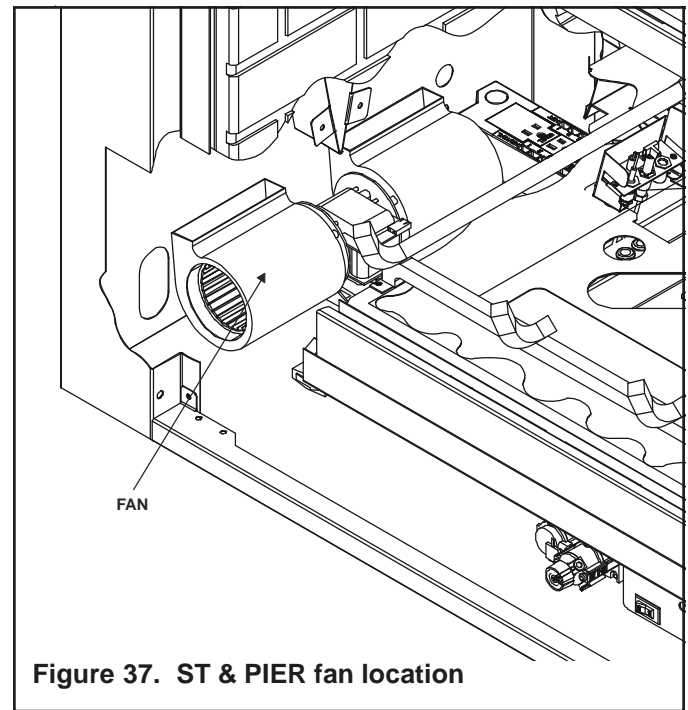

ST & Pier fan location

It is recommended to position the fan on the same side of the fireplace as the vent collars are on. This will provide the best air flow (see Figure 37).

Step 9. Finishing

Figures 38 and 39 show the minimum vertical and corresponding maximum horizontal dimensions of fireplace mantels or other combustible projections above the top front edge of the fireplace. See Figures 4 and 5 for other fireplace clearances. **Only non-combustible materials may be used to cover the black fireplace front.**



WARNING: WHEN FINISHING THE FIREPLACE, NEVER OBSTRUCT OR MODIFY THE AIR INLET/OUTLET GRILLES IN ANY MANNER.

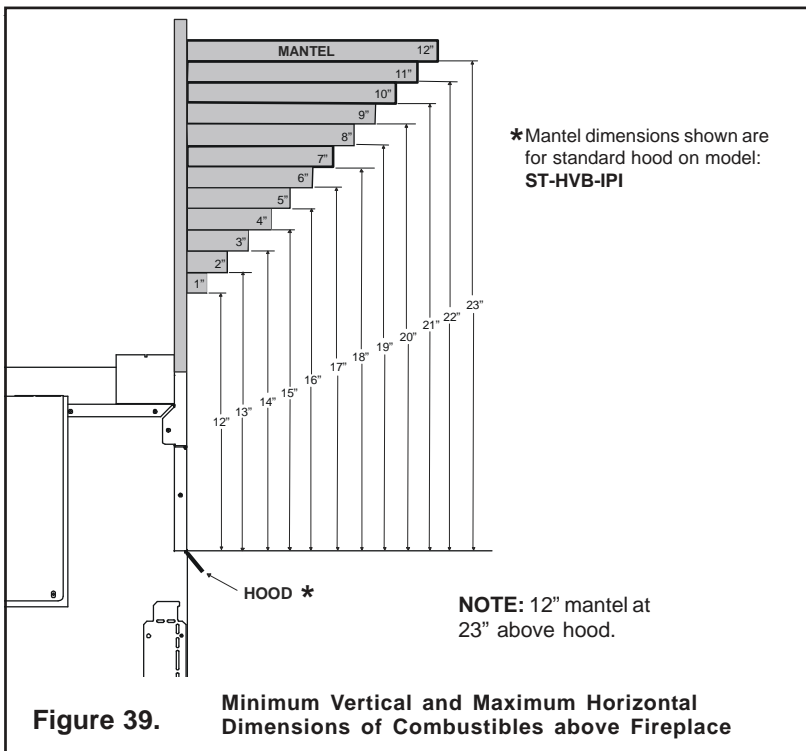
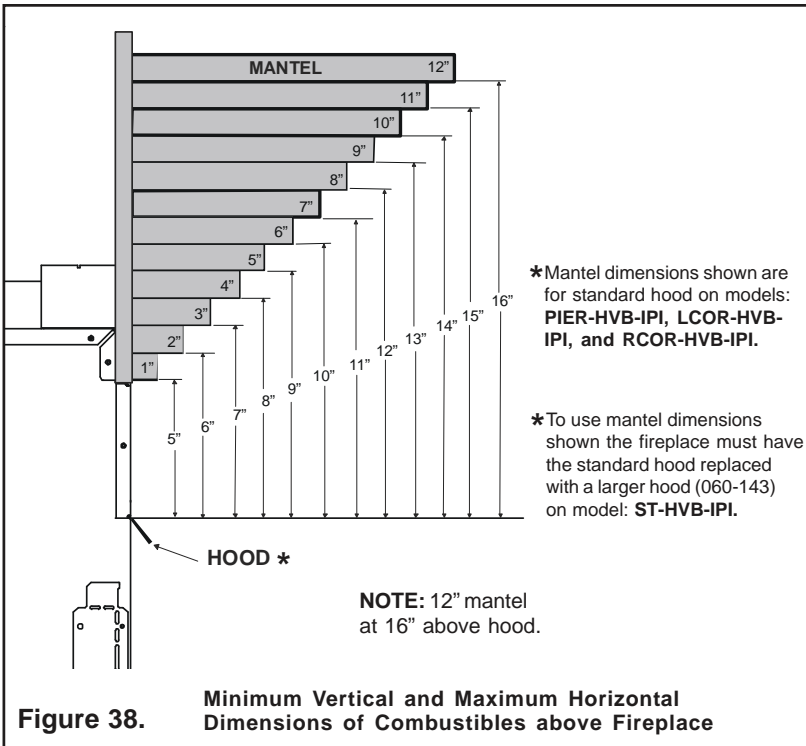

CAUTION: IF JOINTS BETWEEN THE FINISHED WALLS AND THE FIREPLACE SURROUND (TOP AND SIDES) ARE SEALED, A 300° F. MINIMUM SEALANT MATERIAL MUST BE USED. THESE JOINTS ARE NOT REQUIRED TO BE SEALED. ONLY NON-COMBUSTIBLE MATERIAL (USING 300° F. MINIMUM ADHESIVE, IF NEEDED) CAN BE APPLIED AS FACING TO THE FIREPLACE SURROUND. SEE THE DIAGRAM BELOW.

NOTE: Sheetrock or other combustible material such as wood can be placed on the top edge and sides of the fireplace.

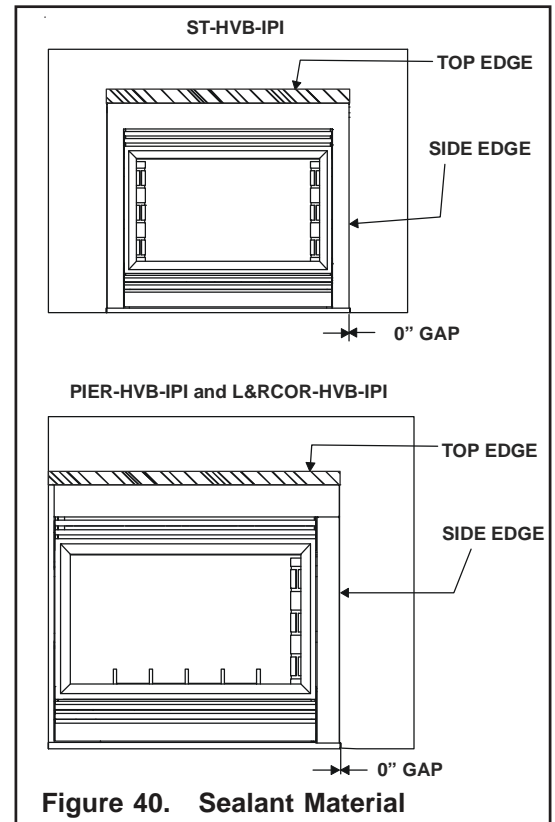

Hearth Extensions

A hearth extension may be desirable for aesthetic reasons. However, ANSI or CAN/CGA testing standards **do not** require hearth extensions for gas fireplace appliances.

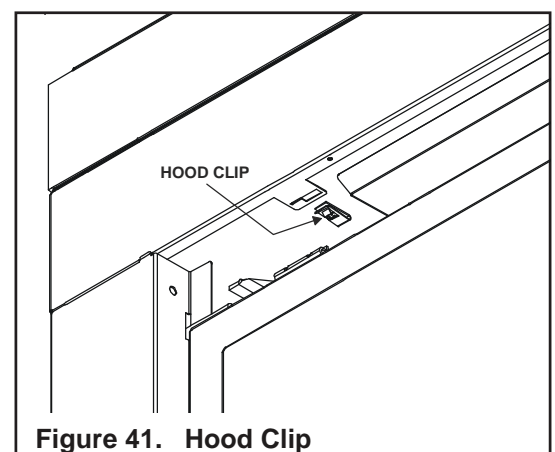

Step 10. Installing Trim, Logs & Ember Material

Installing the Trim

Combustible materials may be brought up to the specified clearances on the side and top front edges of the fireplace, but **MUST NEVER** overlap onto the front face. The joints between the finished wall and the fireplace top and sides can only be sealed with a 300° F. (149° C) minimum sealant.



WARNING: WHEN FINISHING THE FIREPLACE, NEVER OBSTRUCT OR MODIFY THE AIR INLET/OUTLET GRILLES IN ANY MANNER.

Install optional marble and brass trim surround kits as desired. Marble, brass, brick, tile, or other non-combustible materials can be used to cover up the gap between combustible material (sheetrock or wood) and the fireplace.

Do not obstruct or modify the air inlet/outlet grilles. When overlapping on both sides, leave enough space so that the bottom grille can be lowered and the trim door removed.

Positioning the Logs

If the gas logs have been factory installed they should not need to be positioned. If the logs have been packaged separately, refer to the instructions that accompany the logs. **Save the log instructions with this manual.**

If sooting occurs, the logs might need to be repositioned slightly to avoid excessive flame impingement.

Shutter Settings

	NG	LP
PIER-HVB-IPI	3/8"	FULL OPEN
ST-HVB-IPI	3/8"	FULL OPEN
L&RCOR-HVB-IPI	3/8"	FULL OPEN

Glass Specifications

<u>Model</u>	<u>Type</u>
PIER-HVB-IPI	TEMPERED
ST-HVB-IPI	TEMPERED
L&RCOR-HVB-IPI	TEMPERED

Heat & Glo fireplaces manufactured with tempered glass may be installed in hazardous locations such as bathtub enclosures as defined by the CPSC. The tempered glass has been tested and certified to the requirements of ANSI Z97.1-1984 and CPSC 16 CFR 1202. (Safety Glazing Certification Council SGCC # 1595 and 1597. Architectural Testing, Inc. Reports 02-31919.01 and 02-31917.01.)

This statement is in compliance with CPSC 16 CFR Section 1201.5 "Certification and labeling requirements" which refers to 15 USC 2063 stating "...Such certificate shall accompany the product or shall otherwise be furnished to any distributor or retailer to whom the product is delivered."

Some local building codes require the use of tempered glass with permanent marking in such locations. Glass meeting this requirement is available from the factory. Please contact your dealer or distributor to order.

Placing the Ember Material

Ember material is shipped with this gas fireplace. The bag labeled Glowing Ember (050-721) is standard glowing ember material.

To place the ember material:

- Remove the wing nuts and glass clips or tension springs around the glass door.
- Remove the glass door from the unit.
- Remove the grate and log set by removing the screws.
- Place dime size pieces of ember material about 1/2 inch apart near port holes in burner top. Do **NOT** press embers into burner ports. Cover the top of the burner with a single layer of ember material.
- Save the remaining ember materials for use during fireplace servicing. The bag of embers provided is sufficient for 3 to 5 applications.
- Replace the glass door and a front trim door on the unit.

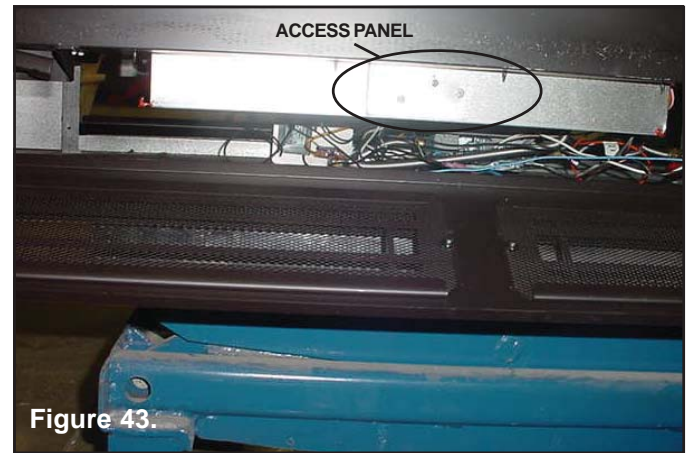

Figure 42 Placement of the Ember Material

Optional Ember Light Kit (Emberkit-MS)

Ember Light Bulb Replacement

In the lower gas valve compartment you will find three access panels for the three light bulbs (see Figure 43).



Using a 5/16" nut driver remove the two bolts (see Figure 44).

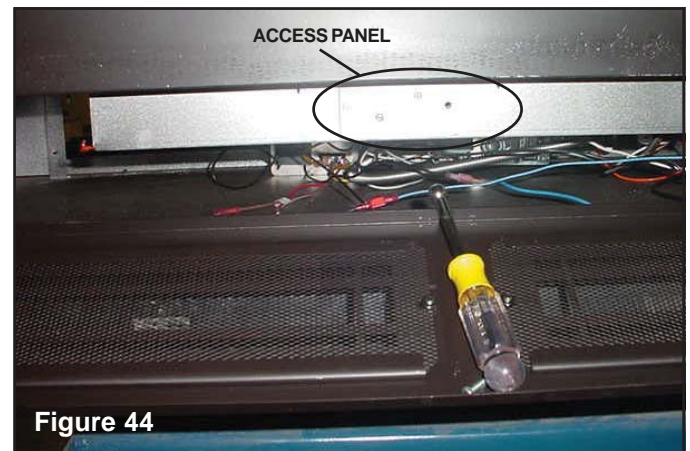

Pull the access panel to expose the light bulb. Wearing clean cotton gloves replace the bulb. Any skin oils which get on a new bulb will greatly shorten the life of the bulb. The bulb can be cleaned with isopropyl alcohol (see Figure 45).

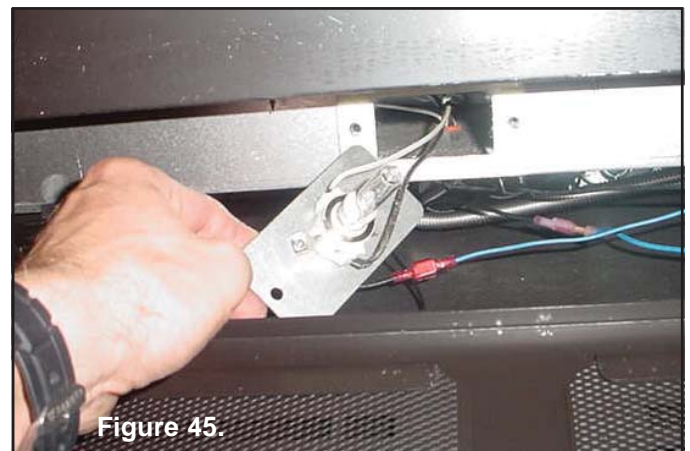

Step 11. Before Lighting the Fireplace

Before lighting the fireplace, be sure to do the following:

- Remove the rubber bands from the log set (see Figure 46).

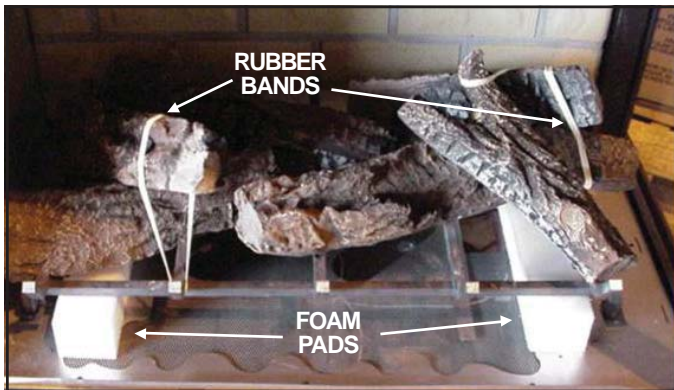

Figure 46.

- Remove the two foam pads which support the log set and grate and allow the log set and grate to rest on the base pan.
- Install the Lava Rock (supplied) to the firebox base pan being careful not to cover the burner with the Lava Rock.

Remove all paperwork from underneath the fireplace.

Review safety warnings and cautions

- Read the **Safety and Warning Information** section at the beginning of this *Installers Guide*.

Double-check for gas leaks

- Before lighting the fireplace, double-check the unit for possible gas leaks.

Double-check vent terminations and front grilles for obstructions.

- Before lighting the fireplace, double-check the unit for possible obstructions that could be blocking the vent terminations or the front grilles.

Double-check for faulty components

- Any component that is found to be faulty **MUST BE** replaced with an approved component. Tampering with the fireplace components is **DANGEROUS** and voids all warranties.

A small amount of air will be in the gas supply lines. When first lighting the fireplace, it will take a few minutes for the lines to purge themselves of this air. Once the purging is complete, the fireplace will light and will operate normally.

Subsequent lightings of the fireplace will not require this purging of air from the gas supply lines, **unless the gas valve has been turned to the OFF position**, in which case the air would have to be purged.

NOTE: The fireplace should be run 3 to 4 hours on the initial start-up. Turn it off and let it cool completely. Remove and clean the glass. Replace the glass and run the fireplace for an additional 8 hours. This will help to cure the products used in the paint and logs.

During this break-in period it is recommended that some windows in the house be opened for air circulation. This will help avoid setting off smoke detectors, and help eliminate any odors associated with the fireplace's initial burning.

Step 12. Lighting the Fireplace

You've reviewed all safety warnings, you've checked the fireplace for gas leaks, you know the vent system is unobstructed, and you've checked for faulty components. Now you're ready to light the fireplace.



WARNING: PLEASE REFER TO THE USER'S MANUAL FOR ALL CAUTIONS, SAFETY, AND WARNING INFORMATION PERTAINING TO THE LIGHTING AND OPERATION OF THE FIREPLACE.

After the Installation



LEAVE THIS INSTALLATION MANUAL WITH THE APPLIANCE FOR FUTURE REFERENCE.

4

Maintaining and Servicing Your Fireplace

Fireplace Maintenance

Although the frequency of your fireplace servicing and maintenance will depend on use and the type of installation, you should have a qualified service technician perform an appliance check-up at the beginning of each heating season. See the table below for specific guidelines regarding each fireplace maintenance task.

IMPORTANT: TURN OFF THE GAS BEFORE SERVICING YOUR FIREPLACE.

Replacing old ember material

Frequency: Once annually, during the checkup.

By: Qualified service technician.

Task: Brush away loose ember material near the burner. Replace old ember material with new dime-size and shape pieces of Golden Ember (GE-93) and Glowing Ember (050-721). New ember material should be placed alternately on top of the burner - a layer of Golden Ember, a layer of Glowing Ember, and so on. Save the remaining ember material and repeat this procedure at your next servicing. For more information, see **Placing Ember Material**.

Cleaning Burner and Controls

Frequency: Once annually.

By: Qualified service technician.

Task: Brush or vacuum the control compartment, fireplace logs and burner areas surrounding the logs.

Cleaning Flame Sensor Rod (IPI Systems)

Frequency: Periodically.

By: Qualified service technician.

Task: Make a visual check of the straight flame sensor rod. Use emery cloth to carefully remove any existing white film or deposits.

Checking Flame Patterns, Flame Height

Frequency: Periodically.

By: Qualified service technician/Home owner.

Task: Make a visual check of your fireplace's flame patterns. Make sure the flames are steady - not lifting or floating. See Figure 47. The flame sensor (IPI) tips should be covered with flame. See Figure 32.

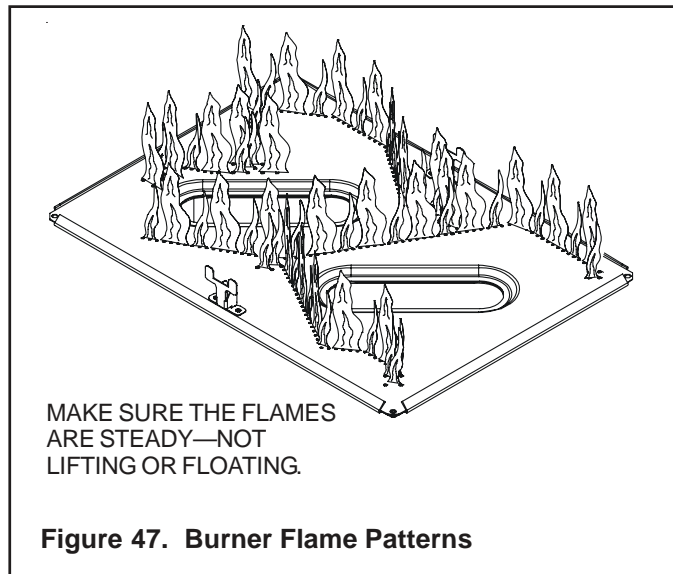

Figure 47. Burner Flame Patterns

Checking Vent System

Frequency: Before initial use and at least annually thereafter, more frequently if possible.

By: Qualified service technician/Home owner.

Task: Inspect the external vent cap on a regular basis to ensure that no debris is interfering with the flow of air. Inspect entire vent system for proper function.

Cleaning Glass Door

Frequency: After the first 3 to 4 hours of use. As necessary after initial cleaning.

By: Home owner.

Task: Remove and clean glass after the first 3 to 4 hours of use. After the initial cleaning, clean as necessary, particularly after adding new ember (flame colorant) material. Film deposits on the inside of the glass door should be cleaned off using a household glass cleaner. **NOTE: DO NOT handle or attempt to clean the door when it is hot and DO NOT use abrasive cleaners.**