

Model:
Infinity

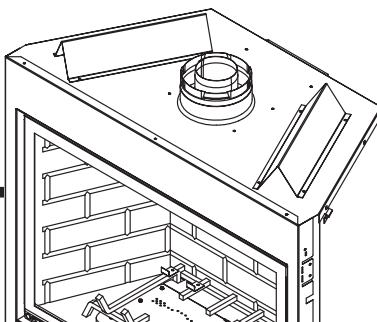

GAS-FIRED



This appliance has been retired.
Service parts pages within have been removed.
For replacement parts, please refer to the individual
service parts list located on the brand websites.

NOTICE



DO NOT DISCARD THIS MANUAL

- Important operating and maintenance instructions included.
- Read, understand and follow these instructions for safe installation and operation.
- Leave this manual with party responsible for use and operation.

DO NOT
DISCARD

⚠ WARNING: If the information in these instructions is not followed exactly, a fire or explosion may result causing property damage, personal injury, or death.

- **DO NOT** store or use gasoline or other flammable vapors and liquids in the vicinity of this or any other appliance.
- **What to do if you smell gas**
 - **DO NOT** try to light any appliance.
 - **DO NOT** touch any electrical switch. **DO NOT** use any phone in your building.
 - Immediately call your gas supplier from a neighbor's phone. Follow the gas supplier's instructions.
 - If you cannot reach your gas supplier, call the fire department.
- Installation and service must be performed by a qualified installer, service agency, or the gas supplier.

⚠ WARNING



HOT SURFACES!

Glass and other surfaces are hot during operation AND cool down.

Hot glass will cause burns.

- **DO NOT** touch glass until it is cooled
 - **NEVER** allow children to touch glass
 - Keep children away
 - **CAREFULLY SUPERVISE** children in same room as fireplace.
 - Alert children and adults to hazards of high temperatures.
- High temperatures may ignite clothing or other flammable materials.**
- Keep clothing, furniture, draperies and other flammable materials away.

This appliance has been supplied with an integral barrier to prevent direct contact with the fixed glass panel. DO NOT operate the appliance with the barrier removed.

Contact your dealer or Hearth & Home Technologies if the barrier is not present or help is needed to properly install one.

In the Commonwealth of Massachusetts installation must be performed by a licensed plumber or gas fitter.

See Table of Contents for location of additional Commonwealth of Massachusetts requirements.

This appliance may be installed as an OEM installation in manufactured home (USA only) or mobile home and must be installed in accordance with the manufacturer's instructions and the manufactured home construction and safety standard, *Title 24 CFR, Part 3280* or *Standard for Installation in Mobile Homes, CAN/CSA Z240MH*, in Canada.

This appliance is only for use with the type(s) of gas indicated on the rating plate.



Installation and service of this appliance should be performed by qualified personnel. Hearth & Home Technologies suggests NFI certified or factory trained professionals, or technicians supervised by an NFI certified professional.

Read this manual before installing or operating this appliance.
Please retain this owner's manual for future reference.

Congratulations

Congratulations on selecting a Heat & Glo gas appliance—an elegant and clean alternative to wood burning appliances. The Heat & Glo gas appliance you have selected is designed to provide the utmost in safety, reliability, and efficiency.

As the owner of a new appliance, you'll want to read and carefully follow all of the instructions contained in this *Owner's Manual*. Pay special attention to all Cautions and Warnings.

This *Owner's Manual* should be retained for future reference. We suggest that you keep it with your other important documents and product manuals.

The information contained in this *Owner's Manual*, unless noted otherwise, applies to all models and gas control systems.

Your new Heat & Glo gas appliance will give you years of durable use and trouble-free enjoyment. Welcome to the Heat & Glo family of appliance products!

<h3>Homeowner Reference Information</h3> <p>Model Name: _____ Date purchased/installed: _____</p> <p>Serial Number: _____ Location on appliance: _____</p> <p>Dealership purchased from: _____ Dealer Phone: _____</p> <p>Notes: _____</p> <p>_____</p>	<p><i>We recommend that you record the following pertinent information about your appliance.</i></p>
---	--

Listing Label Information/Location

The model information regarding your specific appliance can be found on the rating plate usually located in the control area of the appliance.

Type of Gas →

Gas and Electric Information →

This product may be covered by one or more of the following patents: (Nos produits sont couverts par un ou plusieurs des brevets suivants): (United States) 4593510, 4686807, 4766876, 4793322, 4811534, 5000162, 5016609, 5076254, 5113843, 5191877, 5218953, 5263471, 5328356, 5341794, 5347983, 5429495, 5452708, 5542407, 5601073, 5613487, 5647340, 5688568, 5762062, 5775408, 5890485, 5931661, 5941237, 5947112, 5996575, 6006743, 6019099, 6048195, 6053165, 6145502, 6170481, 6237588, 6296474, 6374822, 6413079, 6439226, 6484712, 6543698, 6550687, 6601579, 6672860, 6688302B2, 6715724B2, 6729551, 6736133, 6748940, 6748942, D320652, D445174, D462436; (Canada) 1297749, 2195264, 2225408; or other U.S. and foreign patents pending (ou autres brevets américains et étrangers en attente).

HEAT & GLO Heat & Glo, a brand of Hearth & Home Technologies, Inc.
No one builds a better fire 7571 215th Street West, Lakeville, MN 55044

GAS-FIRED
UL US LISTED

Not for use with solid fuel.
(Ne doit pas être utilisé avec un combustible solide).

Type of Gas (Sorte De Gaz): **NATURAL GAS** This appliance must be installed in accordance with local codes, if any; if not, follow ANSI Z223.1 in the USA or CAN/CGA B149 installation codes. *(Installer l'appareil selon les codes ou règlements locaux ou, en l'absence de tels règlements, selon les codes d'installation CAN/CGA-B149.)*

ANSI Z21XX-XXXX - CSA 2.XX-MXX - UL307B

Minimum Permissible Gas Supply for Purposes of Input Adjustment.

Approved Minimum (De Gaz) Acceptable	0.0 in w.c.	(Po. Col. d'eau)
Maximum Pressure (Pression)	0.0 in w.c.	(Po. Col. d'eau)
Maximum Manifold Pressure (Pression)	0.0 in w.c.	(Po. Col. d'eau)
Minimum Manifold Pressure (Pression)	0.0 in w.c.	(Po. Col. d'eau)

Total Electrical Requirements: 000Vac, 00Hz., less than 00 Amperes

MADE IN USA

		IN CANADA	
ALTITUDE:	0-0000 FT.	0000-0000FT.	Model: XXXXXXXX
MAX. INPUT BTUH:	00,000	00,000	(Modele): _____
MIN. INPUT BTUH:	00,000	00,000	Serial XXXXXXXX
ORIFICE SIZE:	#XXXXXX	#XXXXXX	(Serie): XXXXXXXX

Model Number →

Serial Number →

Table of Contents

1 Listing and Code Approvals

A. Appliance Certification	4
B. Glass Specifications	4
C. BTU Specifications	4
D. High Altitude Installations	4
E. Non-Combustible Materials Specification	4
F. Combustible Materials Specification	4
G. Electrical Codes	4
H. Requirements for the Commonwealth of Massachusetts	5

2 Getting Started

A. Design and Installation Considerations	6
B. Tools and Supplies Needed	6
C. Inspect Appliance and Components	6

3 Framing and Clearances

A. Selecting Appliance Location	7
B. Constructing the Appliance Chase	8
C. Clearances	8
D. Mantel Projections	9
E. Flooring Considerations	9
F. Hearth Extension	9

4 Termination Locations

A. Vent Termination Minimum Clearances	10
B. Vent Termination	10

5 Vent Information and Diagrams

A. Vent Table Key	13
B. Use of Elbows	13
C. Measuring Standards	13
D. Outside Air	14

6 Vent Clearances and Framing

A. Pipe Clearances to Combustibles	16
B. Wall Penetration Framing	16
C. Vertical Penetration Framing	17
D. Install Attic Insulation Shield	18

7 Appliance Preparation

A. Top Vent	19
B. Securing and Leveling the Appliance	20

8 Installing Vent Pipe

A. Assemble Vent Sections	21
B. Assemble Slip Sections	22
C. Secure the Vent Sections	22
D. Disassemble Vent Sections	23
E. Install Decorative Ceiling Components	23
F. Install Metal Roof Flashing	24
G. Assemble and Install Storm Collar	24
H. Install Vertical Termination Cap	25
I. Install Decorative Wall Components	25
J. Heat Shield Requirements for Horizontal Termination	25
K. Install Horizontal Termination Cap	26

9 Gas Information

A. Fuel Conversions	27
B. Gas Pressures	27
C. Gas Connection	27

10 Electrical Information

A. Recommendation for Wire	29
B. Optional Accessories	29
C. Connecting to the Appliance	29
D. Intellifire Ignition System Wiring	29
E. Junction Box Installation	31

11 Finishing

A. Mantel Projections	32
B. Facing Material	32
C. Flooring Considerations	32

12 Appliance Setup

A. Remove Shipping Materials	33
B. Clean the Appliance	33
C. Accessories	33
D. Pilot Air Deflector and Grate	33
E. Lava Rock, Vermiculite, Rockwool/Ember Placement	33
F. Positioning the Logs	34
G. Glass Assembly	37
H. Grilles and Trim	37
I. Shutter Setting	37

13 Operating Instructions

A. Before Lighting Appliance	38
B. Lighting Instructions (IPI)	39
C. After Appliance is Lit	40
D. Frequently Asked Questions	40

14 Troubleshooting

A. Intellifire Ignition System	41
--	----

15 Maintaining and Servicing Appliance

A. Maintenance Tasks	44
--------------------------------	----

16 Reference Materials

A. Appliance Dimension Diagram	45
B. Vent Components Diagrams	46
C. Service Parts	48
D. Limited Lifetime Warranty	51
E. Contact Information	53

➔ = Contains updated information.

1 Listing and Code Approvals

A. Appliance Certification

MODELS: Infinity
LABORATORY: Underwriters Laboratories, Inc. (UL)
TYPE: Direct Vent Gas Appliance Heater
STANDARD: ANSI Z21.50-2000 • CSA2.22-M98 • UL307B

This product is listed to ANSI standards for “Vented Gas Appliance Heaters” and applicable sections of “Gas Burning Heating Appliances for Manufactured Homes and Recreational Vehicles”, and “Gas Fired Appliances for Use at High Altitudes”.

NOT INTENDED FOR USE AS A PRIMARY HEAT SOURCE.
 This appliance is tested and approved as either supplemental room heat or as a decorative appliance. It should not be factored as primary heat in residential heating calculations.

B. Glass Specifications

Hearth & Home Technologies appliances manufactured with tempered glass may be installed in hazardous locations such as bathtub enclosures as defined by the Consumer Product Safety Commission (CPSC). The tempered glass has been tested and certified to the requirements of **ANSI Z97.1** and **CPSC 16 CFR 1202** (Safety Glazing Certification Council **SGCC# 1595** and **1597**. Architectural Testing, Inc. Reports **02-31919.01** and **02-31917.01**).

This statement is in compliance with **CPSC 16 CFR Section 1201.5** “Certification and labeling requirements” which refers to **15 U.S. Code (USC) 2063** stating “...Such certificate shall accompany the product or shall otherwise be furnished to any distributor or retailer to whom the product is delivered.”

Some local building codes require the use of tempered glass with permanent marking in such locations. Glass meeting this requirement is available from the factory. Please contact your dealer or distributor to order.

Note: This installation must conform with local codes. In the absence of local codes you must comply with the National Fuel Gas Code, ANSI Z223.1-latest edition in the U.S.A. and the CAN/CGA B149 Installation Codes in Canada.

C. BTU Specifications

Models (U.S. or Canada)		Maximum Input BTU/h	Orifice Size (DMS)
INFINITY (NG)	US (0-2000 FT)	35,000	34
	CANADA (2000-4500 FT)	31,500	35

D. High Altitude Installations

U.L. Listed gas appliances are tested and approved without requiring changes for elevations from 0 to 2000 feet in the U.S.A. and Canada.

When installing this appliance at an elevation above 2000 feet, it may be necessary to decrease the input rating by changing the existing burner orifice to a smaller size. Input rate should be reduced by 4% for each 1000 feet above a 2000 foot elevation in the U.S.A., or 10% for elevations between 2000 and 4500 feet in Canada. If the heating value of the gas has been reduced, these rules do not apply. To identify the proper orifice size, check with the local gas utility.

If installing this appliance at an elevation above 4500 feet (in Canada), check with local authorities.

WARNING

Do NOT use this appliance if any part has been under water. Immediately call a qualified service technician to inspect the appliance and to replace any part of the control system and any gas control which has been under water.

E. Non-Combustible Materials Specification

Material which will not ignite and burn. Such materials are those consisting entirely of steel, iron, brick, tile, concrete, slate, glass or plasters, or any combination thereof.

Materials that are reported as passing **ASTM E 136, Standard Test Method for Behavior of Materials in a Vertical Tube Furnace at 750°C**, shall be considered non-combustible materials.

F. Combustible Materials Specification

Materials made of or surfaced with wood, compressed paper, plant fibers, plastics, or other material that can ignite and burn, whether flame proofed or not, or whether plastered or unplastered shall be considered combustible materials.

G. Electrical Codes

NOTICE: This appliance must be electrically wired and grounded in accordance with local codes or, in the absence of local codes, with **National Electric Code ANSI/NFPA 70-latest edition** or the **Canadian Electric Code CSA C22.1**.

- A 110-120 VAC circuit for this product must be protected with ground-fault circuit-interrupter protection, in compliance with the applicable electrical codes, when it is installed in locations such as in bathrooms or near sinks.

Note: The following requirements reference various Massachusetts and national codes not contained in this document.

H. Requirements for the Commonwealth of Massachusetts

For all side wall horizontally vented gas fueled equipment installed in every dwelling, building or structure used in whole or in part for residential purposes, including those owned or operated by the Commonwealth and where the side wall exhaust vent termination is less than seven (7) feet above finished grade in the area of the venting, including but not limited to decks and porches, the following requirements shall be satisfied:

Installation of Carbon Monoxide Detectors

At the time of installation of the side wall horizontal vented gas fueled equipment, the installing plumber or gas fitter shall observe that a hard wired carbon monoxide detector with an alarm and battery back-up is installed on the floor level where the gas equipment is to be installed. In addition, the installing plumber or gas fitter shall observe that a battery operated or hard wired carbon monoxide detector with an alarm is installed on each additional level of the dwelling, building or structure served by the side wall horizontal vented gas fueled equipment. It shall be the responsibility of the property owner to secure the services of qualified licensed professionals for the installation of hard wired carbon monoxide detectors.

In the event that the side wall horizontally vented gas fueled equipment is installed in a crawl space or an attic, the hard wired carbon monoxide detector with alarm and battery back-up may be installed on the next adjacent floor level.

In the event that the requirements of this subdivision can not be met at the time of completion of installation, the owner shall have a period of thirty (30) days to comply with the above requirements; provided, however, that during said thirty (30) day period, a battery operated carbon monoxide detector with an alarm shall be installed.

Approved Carbon Monoxide Detectors

Each carbon monoxide detector as required in accordance with the above provisions shall comply with NFPA 720 and be ANSI/UL 2034 listed and IAS certified.

Signage

A metal or plastic identification plate shall be permanently mounted to the exterior of the building at a minimum height of eight (8) feet above grade directly in line with the exhaust vent terminal for the horizontally vented gas fueled heating appliance or equipment. The sign shall read, in print size no less than one-half (1/2) inch in size, "**GAS VENT DIRECTLY BELOW. KEEP CLEAR OF ALL OBSTRUCTIONS**".

Inspection

The state or local gas inspector of the side wall horizontally vented gas fueled equipment shall not approve the installation unless, upon inspection, the inspector observes carbon monoxide detectors and signage installed in accordance with the provisions of 248 CMR 5.08(2)(a)1 through 4.

Exemptions

The following equipment is exempt from 248 CMR 5.08(2)(a)1 through 4:

- The equipment listed in Chapter 10 entitled "Equipment Not Required To Be Vented" in the most current edition of NFPA 54 as adopted by the Board; and
- Product Approved side wall horizontally vented gas fueled equipment installed in a room or structure separate from the dwelling, building or structure used in whole or in part for residential purposes.

MANUFACTURER REQUIREMENTS

Gas Equipment Venting System Provided

When the manufacturer of Product Approved side wall horizontally vented gas equipment provides a venting system design or venting system components with the equipment, the instructions provided by the manufacturer for installation of the equipment and the venting system shall include:

- Detailed instructions for the installation of the venting system design or the venting system components; and
- A complete parts list for the venting system design or venting system.

Gas Equipment Venting System **NOT** Provided

When the manufacturer of a Product Approved side wall horizontally vented gas fueled equipment does not provide the parts for venting the flue gases, but identifies "special venting systems", the following requirements shall be satisfied by the manufacturer:

- The referenced "special venting system" instructions shall be included with the appliance or equipment installation instructions; and
- The "special venting systems" shall be Product Approved by the Board, and the instructions for that system shall include a parts list and detailed installation instructions.

A copy of all installation instructions for all Product Approved side wall horizontally vented gas fueled equipment, all venting instructions, all parts lists for venting instructions, and/or all venting design instructions shall remain with the appliance or equipment at the completion of the installation.

See Gas Connection section for additional Commonwealth of Massachusetts requirements.

2 Getting Started

A. Design and Installation Considerations

Heat & Glo direct vent gas appliances are designed to operate with all combustion air siphoned from outside of the building and all exhaust gases expelled to the outside. No additional outside air source is required.

CAUTION

Check building codes prior to installation.

- Installation **MUST** comply with local, regional, state and national codes and regulations.
- Consult local building, fire officials or authorities having jurisdiction about restrictions, installation inspection, and permits.

When planning an appliance installation, it's necessary to determine the following information before installing:

- Where the appliance is to be installed.
- The vent system configuration to be used.
- Gas supply piping.
- Electrical wiring.
- Framing and finishing details.
- Whether optional accessories—devices such as a fan, wall switch, or remote control—are desired.



WARNING

- Keep appliance dry.
- Mold or rust may cause odors.
- Water may damage controls.



B. Tools and Supplies Needed

Before beginning the installation be sure that the following tools and building supplies are available.

Reciprocating saw	Framing material
Pliers	High temperature caulking material
Hammer	Gloves
Phillips screwdriver	Framing square
Flat blade screwdriver	Electric drill and bits (1/4 in.)
Plumb line	Safety glasses
Level	1/2 - 3/4 inch length, #6 or #8 Self-drilling screws
Manometer	Voltmeter
Tape measure	Noncorrosive leak check solution
One 1/4 inch female connection (for optional fan).	

C. Inspect Appliance and Components



WARNING

Inspect appliance and components for damage. Damaged parts may impair safe operation.

- Do NOT install damaged components.
 - Do NOT install incomplete components.
 - Do NOT install substitute components.
- Report damaged parts to dealer.



- Carefully remove the appliance and components from the packaging.
- The vent system components and trim doors are shipped in separate packages.
- The gas logs may be packaged separately and must be field installed.
- Report to your dealer any parts damaged in shipment, particularly the condition of the glass.
- **Read all of the instructions before starting the installation. Follow these instructions carefully during the installation to ensure maximum safety and benefit.**



WARNING

Hearth & Home Technologies disclaims any responsibility for, and the warranty will be voided by, the following actions:

- Installation and use of any damaged appliance or vent system component.
- Modification of the appliance or vent system.
- Installation other than as instructed by Hearth & Home Technologies.
- Improper positioning of the gas logs or the glass door.
- Installation and/or use of any component part not approved by Hearth & Home Technologies.

Any such action may cause a fire hazard.

3 Framing and Clearances

Note:

- Illustrations reflect typical installations and are FOR DESIGN PURPOSES ONLY.
- Illustrations/diagrams are not drawn to scale.
- Actual installation may vary due to individual design preference.

A. Selecting Appliance Location

When selecting a location for your appliance it is important to consider the required clearances to walls (see figure 3.1).

⚠ WARNING



Fire Risk

Provide adequate clearance:

- Around air openings
- To combustibles
- For service access

Locate appliance away from traffic areas.

Note: For actual appliance dimensions refer to Section 16.

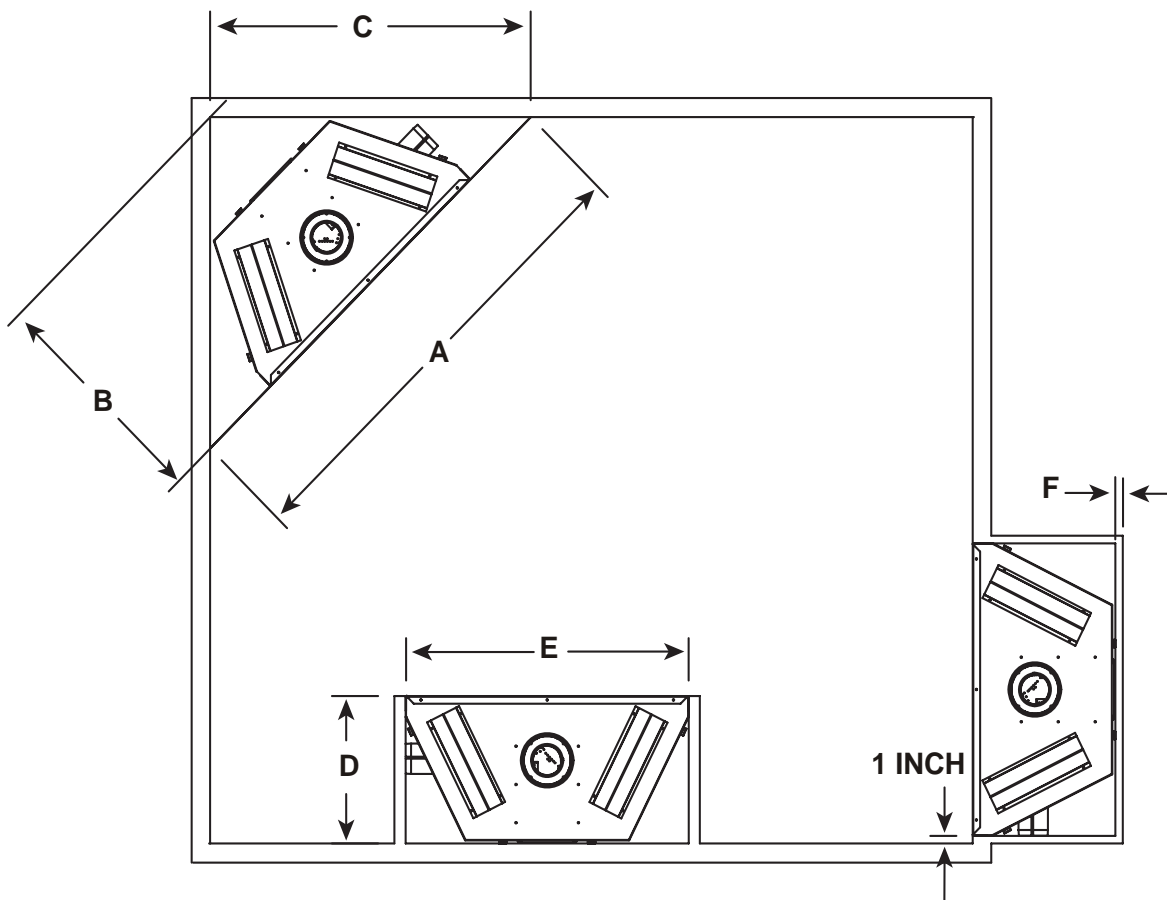

In addition to these framing dimensions, also reference the following sections:

- Clearances and Mantel Projections (**Sections 3.C and 3.D**)
- Vent Clearances and Framing (**Section 6**).

	A	B	C	D	E	F
Inches	61-1/4	30-5/8	43-5/16	20	39-1/4	1/2
Millimeters	1556	778	1100	508	997	13

Figure 3.1 Appliance Locations

B. Constructing the Appliance Chase

A chase is a vertical boxlike structure built to enclose the gas appliance and/or its vent system. Vertical vents that run on the outside of a building may be, but are not required to be, installed inside a chase.

Construction of the chase may vary with the type of building. These instructions are not substitutes for the requirements of local building codes. Local building codes **MUST** be checked.

Chases should be constructed in the manner of all outside walls of the home to prevent cold air drafting problems. The chase should not break the outside building envelope in any manner.

Walls, ceiling, base plate and cantilever floor of the chase should be insulated. Vapor and air infiltration barriers should be installed in the chase as per regional codes for the rest of the home. Additionally, in regions where cold air infiltration may be an issue, the inside surfaces may be sheetrocked and taped for maximum air tightness.

To further prevent drafts, the wall shield and ceiling firestops should be caulked with high temperature caulk to seal gaps. Gas line holes and other openings should be caulked with high temperature caulk or stuffed with

unfaced insulation. If the appliance is being installed on a cement surface, a layer of plywood may be placed underneath to prevent conducting cold up into the room.

C. Clearances

⚠ WARNING

Fire Risk.
Odor Risk.

- Install appliance on hard metal or wood surfaces extending full width and depth of appliance.
- Do NOT install appliance directly on carpeting, vinyl, tile or any combustible material other than wood.

⚠ WARNING

Fire Risk.

- Construct chase to all clearance specifications in manual.
- Locate and install appliance to all clearance specifications in manual.

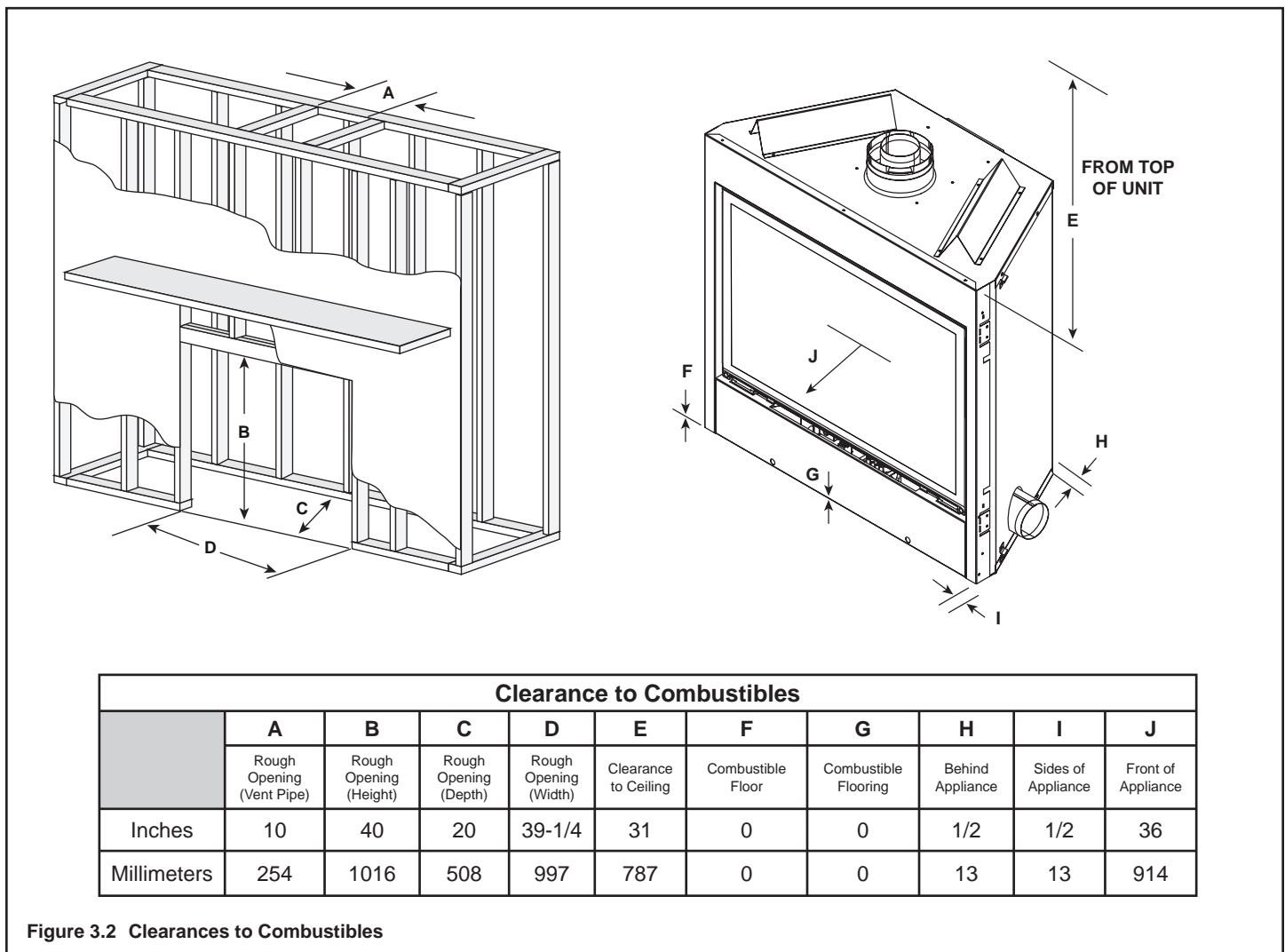
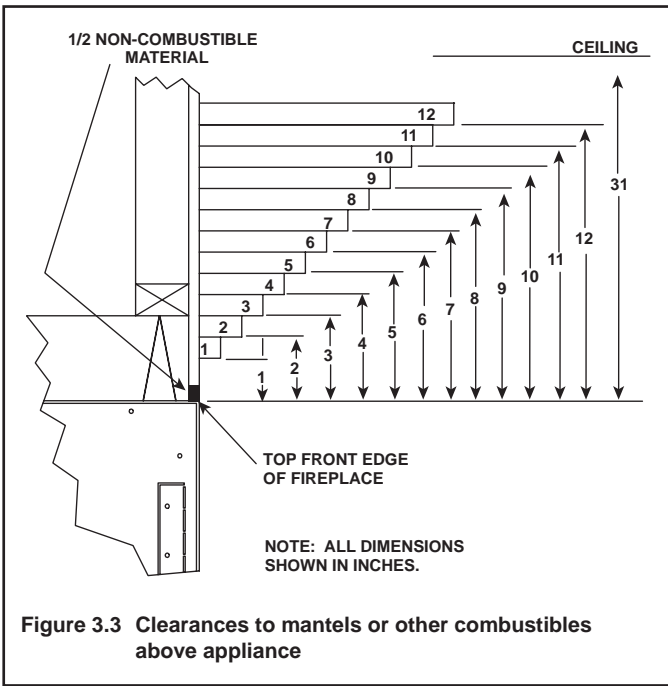

Figure 3.2 Clearances to Combustibles

D. Mantel Projections



E. Flooring Considerations

If the fireplace is to be installed prior to finished floor construction (i.e. tile, carpet, etc.) in front of the fireplace, provisions must be made to accommodate for the difference in height between the floor underneath the fireplace and the finished floor to be installed in front of the fireplace.

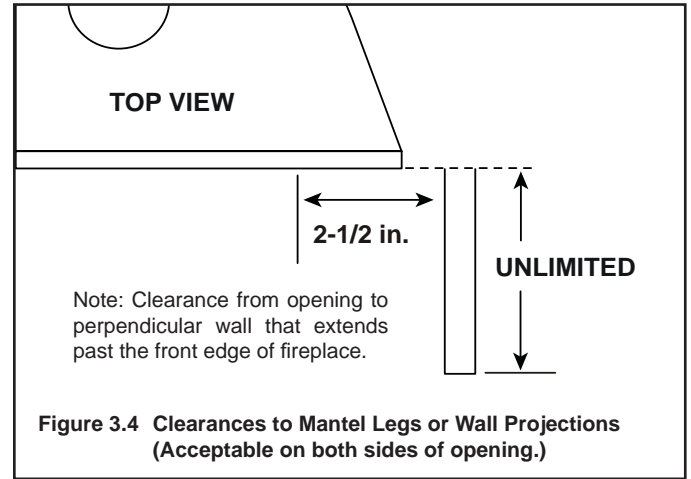

F. Hearth Extension

A hearth extension may be desirable for aesthetic reasons. However, ANSI or CAN/CGA testing standards do not require hearth extensions for gas fireplace appliances.

4 Termination Locations

A. Vent Termination Minimum Clearances

⚠ WARNING	
	Fire Risk. Explosion Risk. Maintain vent clearance to combustibles as specified.
	<ul style="list-style-type: none">Do not pack air space with insulation or other materials. Failure to keep insulation or other materials away from vent pipe may cause fire.

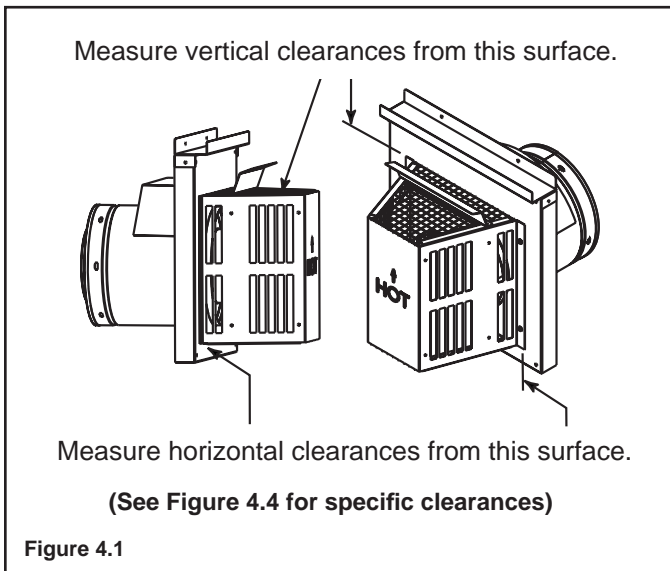

B. Vent Termination

For Horizontal Terminations - The trapezoidal cap SLP-TRAP1 and SLP-TRAP2 are the only caps that are approved to terminate a horizontal vent run.

For Horizontal Terminations - To attach and secure the termination to the last section of horizontal vent:

- Rotate and interlock the ends as described at the beginning of the Installing Vent Components section.
- The termination kit should pass through the wall firestop from the exterior of the building.
- Adjust the termination cap to its final exterior position on the building.

⚠ WARNING	
	Fire Risk.
	The termination cap must be oriented so that the arrow is pointing up.
	If termination cap is installed incorrectly, the clearances to combustibles will not be met.

Fasten heat shield and firestop simultaneously.

For trapezoidal cap termination kits:

- Using screws secure the cap to the exterior wall through the flanges in the cap.
- Seal the joint between the pipe and the exterior firestop.

The bottom of the vent termination cap must be a minimum of 12 inches (305 mm) above ground level (grade). The top of the cap must be a minimum of 18 inches (457 mm) below combustible material, such as a deck. The side of the cap must be a minimum of 6 inches (152 mm) away from a parallel outside wall. Venting terminals shall not be recessed into a wall or siding. See figure 4.5 for vent termination clearances.

Note: For vinyl siding use protector kit VPK-Infinity or DVP-BEK2.

Figure 4.2 specifies minimum vent heights for various pitched roofs.

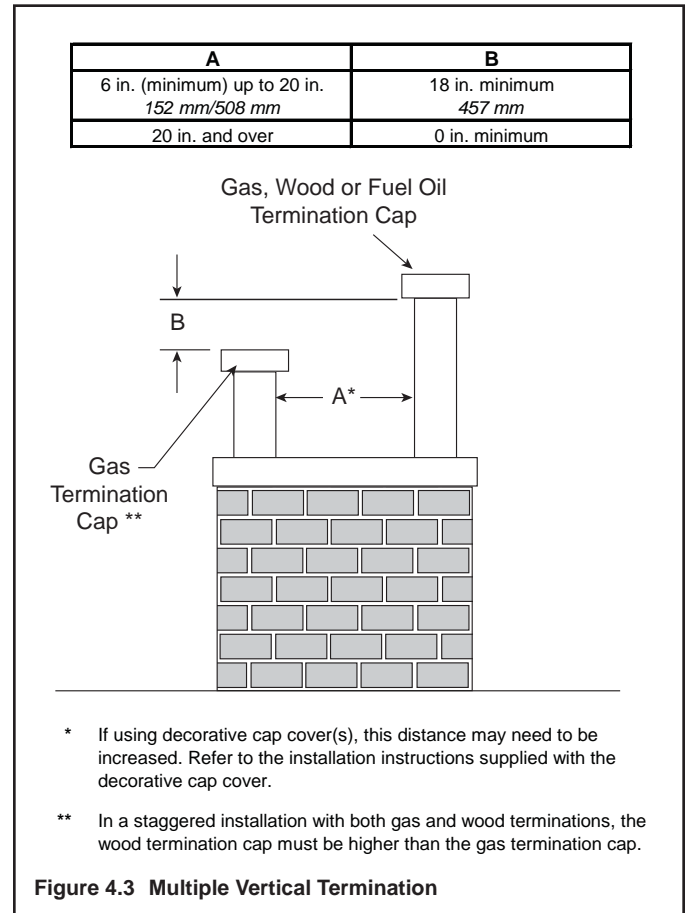
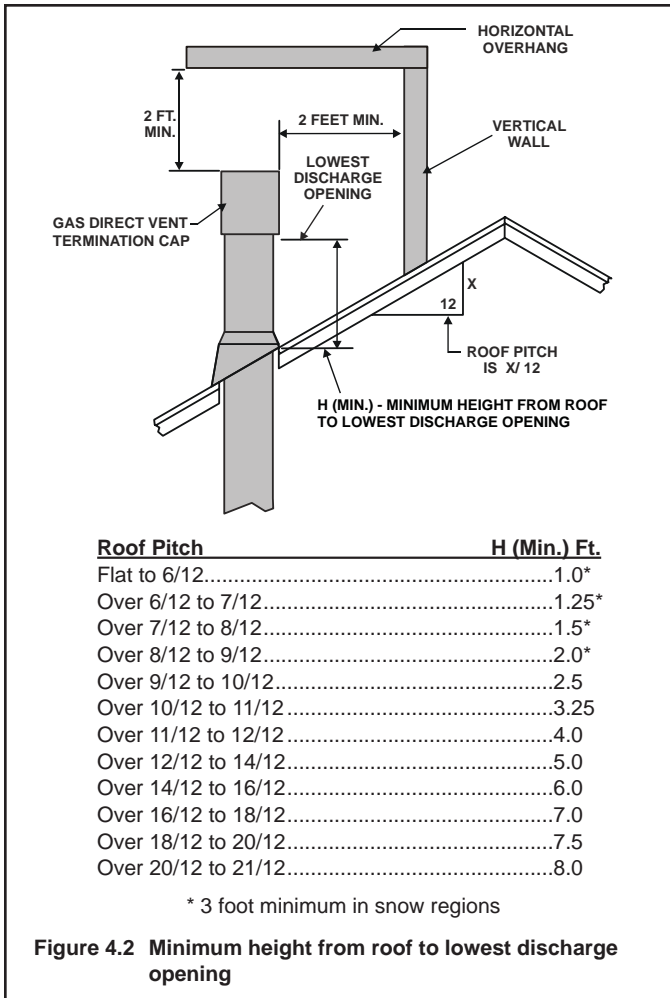

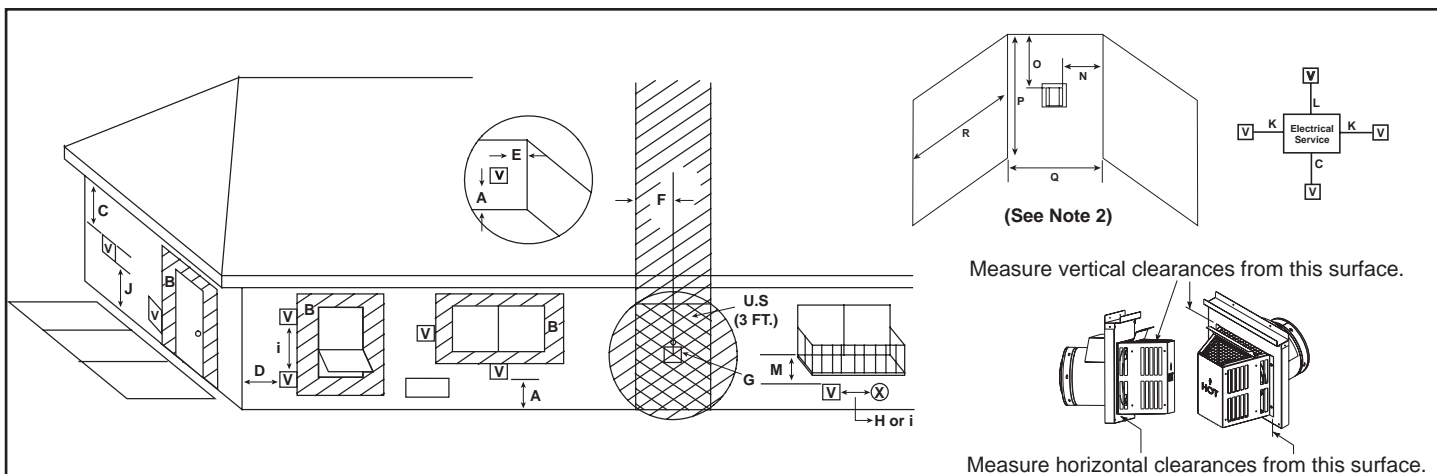

V = VENT TERMINAL **X** = AIR SUPPLY INLET = AREA WHERE TERMINAL IS NOT PERMITTED

- A = 12 inches.....clearances above grade, veranda, porch, deck or balcony (See Note 1)
- B = 12 inches.....clearances to window or door that may be opened, or to permanently closed window. (Glass)
- C = 18 inches.....vertical clearance to unventilated soffit or to ventilated soffit located above the terminal
30 inchesfor vinyl clad soffits and below electrical service
- D = 9 inches.....clearance to outside corner
- E = 6 inches.....clearance to inside corner
- F = 3 ft. (Canada).....not to be installed above a gas meter/regulator assembly within 3 feet (90 cm) horizontally from the center-line of the regulator
- G = 3 ft.....clearance to gas service regulator vent outlet
- H = 9 inches (U.S.A.)
12 inches (Canada) clearance to non-mechanical air supply inlet to building or the combustion air inlet to any other appliance (See Note 2)
- i = 3 ft. (U.S.A.)
6 ft. (Canada).....clearance to a mechanical (powered) air supply inlet (See Note 2)

- J** = 7 ft..... clearance above paved sidewalk or a paved driveway located on **public** property (See Note 1)
- K = 6 inches.....clearance from sides of electrical service (See Note 5)
- L = 12 inches.....clearance above electrical service (See Note 5)

Covered Alcove Applications

- M*** = 18 inches clearance under veranda, porch, deck, balcony or overhang
42 inches vinyl
- N = 6 inches non-vinyl sidewalls
12 inches vinyl sidewalls
- O = 18 inches non-vinyl soffit and overhang
42 inches vinyl soffit and overhang
- P = 8 ft.

	Q_{MIN}	R_{MAX}
1 cap	3 feet	2 x Q _{ACTUAL}
2 caps	6 feet	1 x Q _{ACTUAL}
3 caps	9 feet	2/3 x Q _{ACTUAL}
4 caps	12 feet	1/2 x Q _{ACTUAL}
Q_{MIN} = # termination caps x 3 R_{MAX} = (2 / # termination caps) x Q _{ACTUAL}		

** a vent shall not terminate directly above a sidewalk or paved driveway which is located between two single family dwellings and serves both dwellings.

*** only permitted if veranda, porch, deck or balcony is fully open on a minimum of 2 sides beneath the floor, or meets Note 2.

Note 1: On private property where termination is less than 7 feet above a sidewalk, driveway, deck, porch, veranda or balcony, use of a listed cap shield is suggested. (See vents components page)

Note 2: Termination in a covered alcove space (spaces open only on one side and with an overhang) are permitted with the dimensions specified for vinyl or non-vinyl siding and soffits. **1.** There must be 3 feet minimum between termination caps. **2.** All mechanical air intakes within 10 feet of a termination cap must be a minimum of 3 feet below the termination cap. **3.** All gravity air intakes within 3 feet of a termination cap must be a minimum of 1 foot below the termination cap.

Note 3: Local codes or regulations may require different clearances.

Note 4: Termination caps may be hot. Consider their proximity to doors or other traffic areas.

Note 5: Location of the vent termination must not interfere with access to the electrical service.

In the U.S and Canada: Vent system termination is **NOT** permitted in screened porches.

Vent system termination is permitted in porch areas with two or more sides open. You must follow all side walls, overhang and ground clearances as stated in the instructions.

Heat & Glo assumes no responsibility for the improper performance of the appliance when the venting system does not meet these requirements.

Figure 4.4 Minimum Clearances for Termination

➔ **CAUTION: IF EXTERIOR WALLS ARE FINISHED WITH VINYL SIDING, IT IS NECESSARY THAT A VINYL PROTECTOR KIT BE INSTALLED.**

5 Vent Information and Diagrams

A. Vent Table Key

The abbreviations listed in this vent table key are used in the vent diagrams.

Symbol	Description
V ₁	First section (closest to appliance) of vertical length
V ₂	Second section of vertical length
H ₁	First section (closest to appliance) of horizontal length
H ₂	Second section of horizontal length

⚠ WARNING



Fire Hazard.

Explosion Risk.

Asphyxiation Risk.

Do NOT connect this gas appliance to a chimney flue serving a separate solid-fuel or gas burning appliance.



- Vent this appliance directly outside.
 - Use separate vent system for this appliance.
- May impair safe operation of this appliance or other appliances connected to the flue.

B. Use of Elbows

CAUTION

ALL vent configuration specifications MUST be followed.

- This product is tested and listed to these specifications.
- Appliance performance will suffer if specifications are not followed.

Diagonal runs have both vertical and horizontal vent aspects when calculating the effects. Use the rise for the vertical aspect and the run for the horizontal aspect (see Figure 5.1).

Two 45° elbows may be used in place of one 90° elbow. On 45° runs, one foot of diagonal is equal to 8-1/2 (216 mm) inches horizontal run and 8-1/2 (216 mm) inches vertical run. A length of straight pipe is allowed between two 45° elbows (see Figure 5.1).

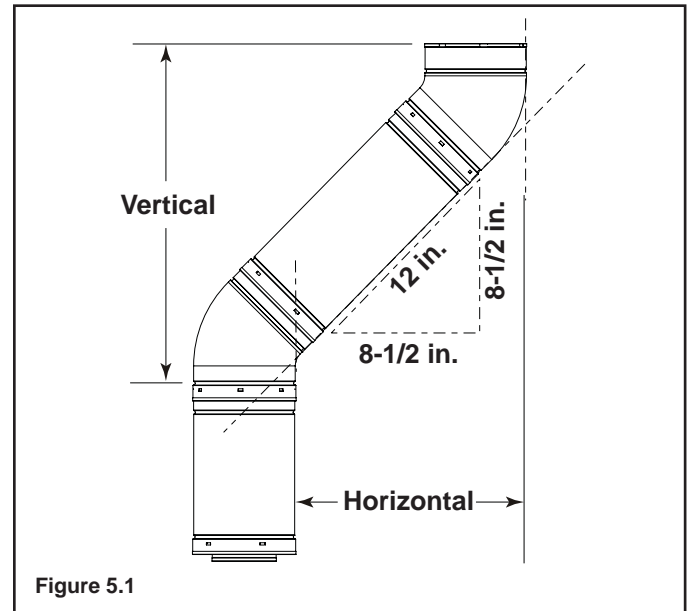

C. Measuring Standards

Vertical and horizontal measurements listed in the vent diagrams were made using the following standards.

- Pipe measurements are shown using the effective length of pipe (see Figure 5.2).
- Horizontal terminations are measured to the outside mounting surface (flange of termination cap) (see Figure 4.1).
- Vertical terminations are measured to bottom of termination cap.
- Horizontal pipe installed level with no rise.

Pipe	Effective Height/Length	
	inches	mm
SLP4	4	102
SLP6	6	152
SLP12	12	305
SLP24	24	610
SLP36	36	914
SLP48	48	1219
SLP6A	2 - 6	51 - 152
SLP12A	2 - 12	51 - 305
SLP-FLEX-2	24	610
SLP-FLEX-3	36	914
SLP-FLEX-5	60	1524
SLP-FLEX-10	120	3048

Effective Height/Length

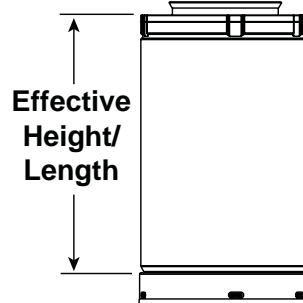

Figure 5.2 SLP Pipe Effective Length

D. Outside Air

CAUTION

Install fresh air intake in the same pressure zone as the exhaust pipe termination cap. Failure to do so may cause over-heating after the unit is shut down, potentially resulting in damaged components.

WARNING



Fire Hazard.

This unit is designed to operate using outside combustion air. It is mandatory to install an AK-CFX air kit. The 4 inch (102 mm) duct collar for the air kit IS PROVIDED ON the fireplace.

The combustion air for this fireplace is supplied by AK-CFX outside air kit. This kit may extend up to 40 feet from the fireplace to the outside air inlet cap (provided with AK-CFX).

It is required to seal all outside air duct connections with an RTV silicone caulk.

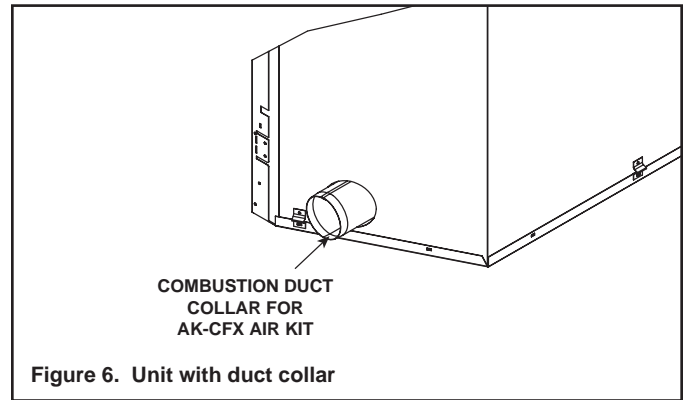

Figure 6. Unit with duct collar

See Table 1 for duct diameter requirements.

It is RECOMMENDED that the outside air inlet cap be installed on the same exterior wall as the SLK-01TRD exhaust termination cap to ensure they are in the same pressure zone. Required distance between intake and exhaust termination caps is 3 feet (USA) and 6 feet (Canada).

Outside air kit AK-CFX must terminate horizontally and must be used with the provided inlet cap.

MINIMUM FLEXIBLE INTAKE DUCTING DIAMETERS

Length of the duct run	Number of bends			
	One 90°	Two 90°	Three 90°	Four 90°
10 feet	4 in.	4 in.	4 in.	4 in.
15 feet	4 in.	4 in.	4 in.	4 in.
20 feet	4 in.	4 in.	4 in.	5 in.
25 feet	4 in.	4 in.	4 in.	5 in.
30 feet	4 in.	4 in.	5 in.	5 in.
35 feet	4 in.	5 in.	5 in.	6 in.
40 feet	4 in.	5 in.	6 in.	6 in.

Upsizing from the minimum diameter of the duct is acceptable. Use an appropriate adapter collar.

Avoid sharp bends, kinks, and sags in the flexible ducting.

If using flexible ducting larger than 4 in., the duct can be reduced back to 4 in. for connection to the intake cap.

Combustion air duct may be vented in any direction, including downward.

Any combination in-between would be applicable.

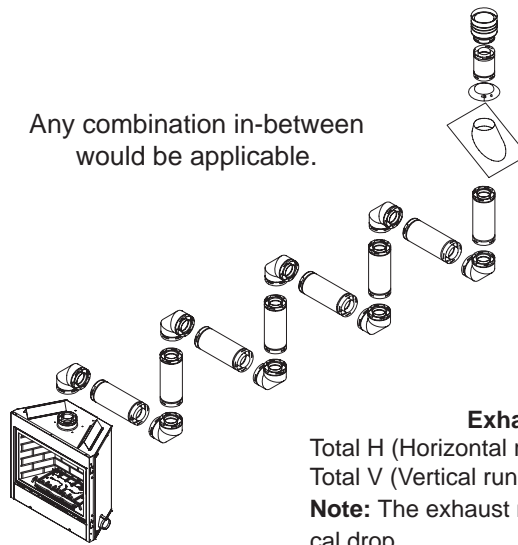

Exhaust Duct

Total H (Horizontal run) = 50 feet maximum.
Total V (Vertical run) = 40 feet maximum.

Note: The exhaust may never have a vertical drop.

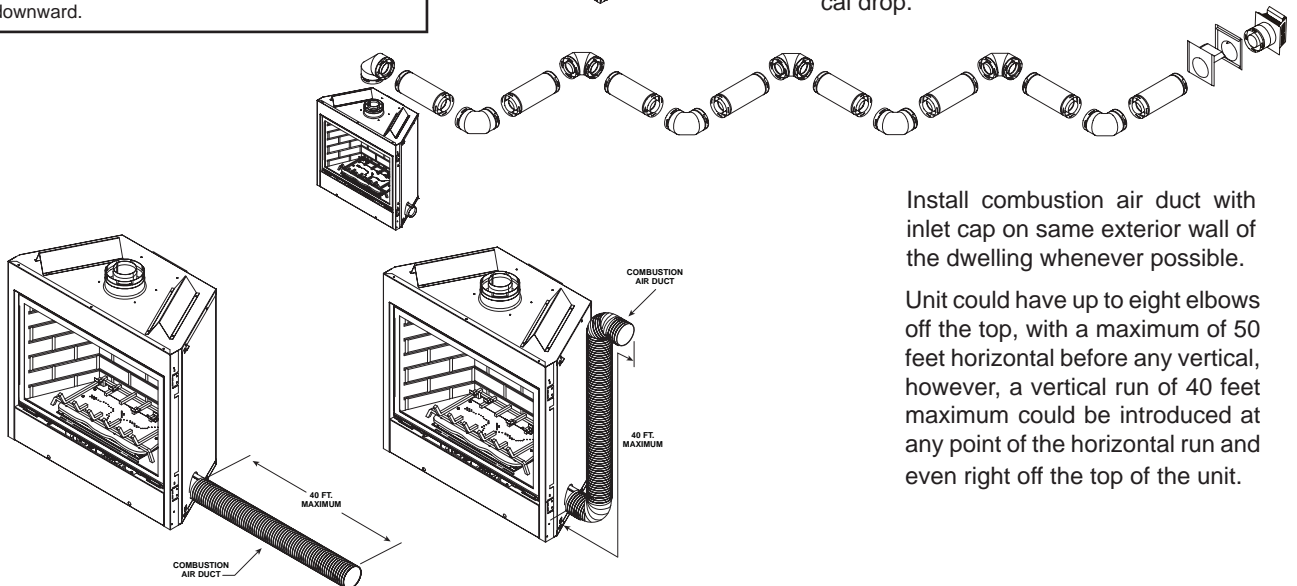

Figure 7.

Install combustion air duct with inlet cap on same exterior wall of the dwelling whenever possible.

Unit could have up to eight elbows off the top, with a maximum of 50 feet horizontal before any vertical, however, a vertical run of 40 feet maximum could be introduced at any point of the horizontal run and even right off the top of the unit.

**STRAIGHT UP
VERTICAL VENTING**
V (FT.)
40' MAX. (12.4 m)

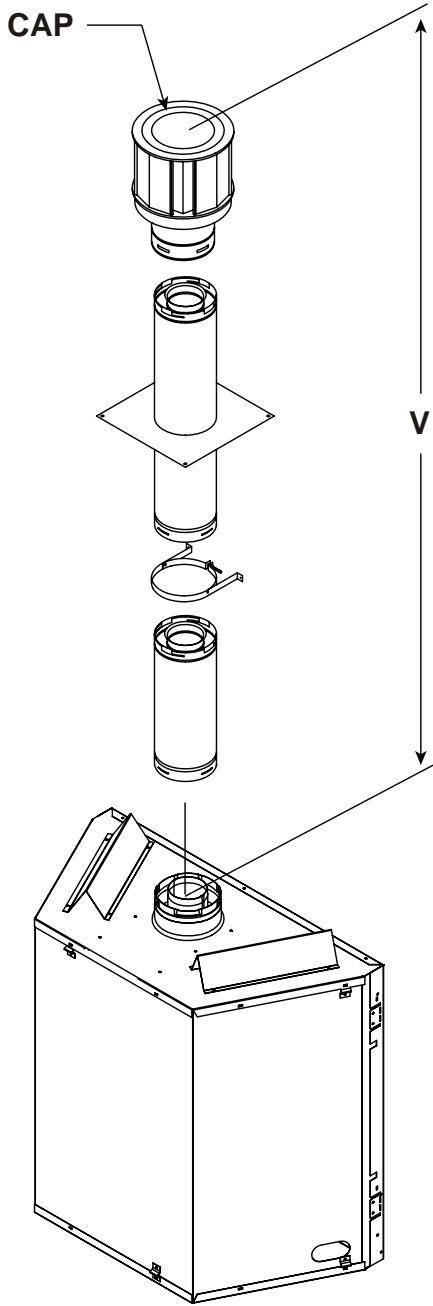



Figure 8. Straight Up Vertical Venting

6 Vent Clearances and Framing

A. Pipe Clearances to Combustibles



WARNING

Fire Risk.
Explosion Risk.

Maintain vent clearance to combustibles as specified.

- Do not pack air space with insulation or other materials.

Failure to keep insulation or other materials away from vent pipe may cause fire.

Note: Heat shields MUST overlap by a minimum of 1-1/2 in. (38 mm).

- **SLP heat shield** - designed to be used on a wall 4-3/8 in. to 7-5/8 in. (111 mm to 194 mm thick).
- If wall thickness is less than 4-3/8 the existing heat shields must be field trimmed. If wall thickness is greater than 7-5/8 in. a DVP-HSM-B will be required.

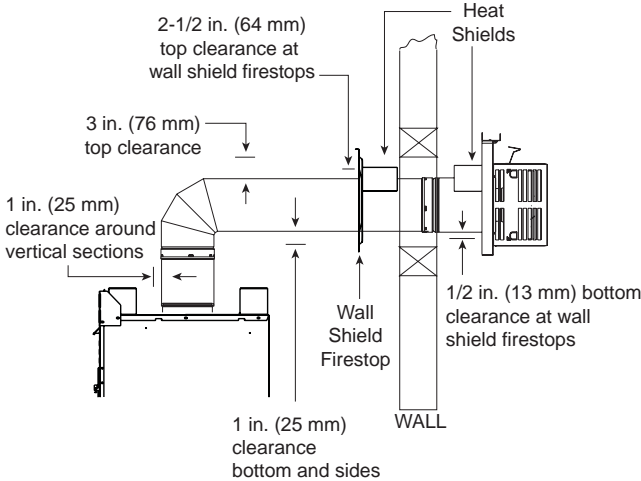

Figure 6.1 Horizontal venting clearances to combustible materials

B. Wall Penetration Framing

Combustible Wall Penetration

Whenever a combustible wall is penetrated, you must frame a hole for the wall shield firestop. The wall shield firestop maintains minimum clearances and prevents cold air infiltration.

- The opening must be framed on all four sides using the same size framing materials as those used in the wall construction.
- SLP pipe - A wall shield firestop must be placed on each side of an interior wall. A minimum 1-1/2 in. (38 mm) overlap of attached heat shields must be maintained.
- See Section 8.L. for information for regarding the installation of a horizontal termination cap.

Non-Combustible Wall Penetration

If the hole being penetrated is surrounded by noncombustible materials such as concrete, a hole with diameter one in. greater than the pipe is acceptable.

Whenever a non-combustible wall is penetrated, the wall shield firestop is only required on one side and no heat shield is necessary.

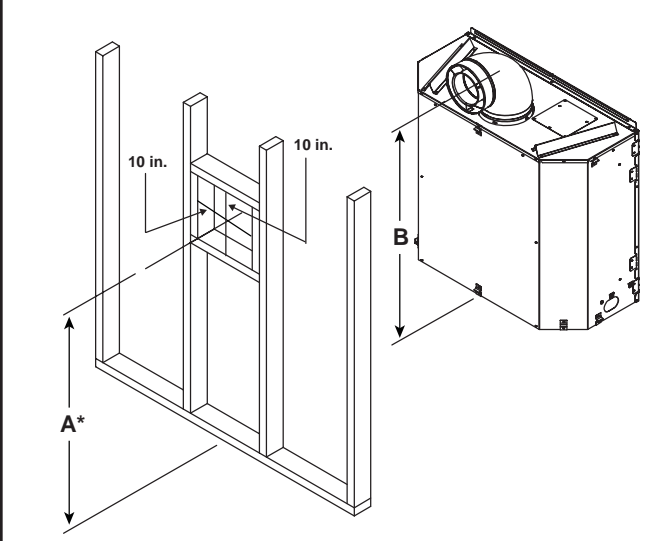

A*	B
44 -3/4 in.	43 -3/4 in.

* Shows center of vent framing hole for top venting. The center of the hole is one (1) inch (25.4 mm) above the center of the horizontal vent pipe.

Figure 6.2 Exterior Wall Hole

C. Vertical Penetration Framing

A ceiling firestop **MUST** be used between floors and attics.

- Frame opening 9 in. x 9 in. (229 mm x 229 mm) whenever the vent penetrates a ceiling/floor (see Figure 6.3).
- Frame the area with the same sized lumber as used in ceiling/floor joist.
- The ceiling firestop may be installed above or below the ceiling joists when installed with an attic insulation shield. It must be under joists between floors that are not insulated. Refer to Figure 6.4.
- Secure with three fasteners on each side.

WARNING! Risk of Fire! DO NOT pack insulation around the vent. Insulation must be kept back from the pipe to prevent overheating.

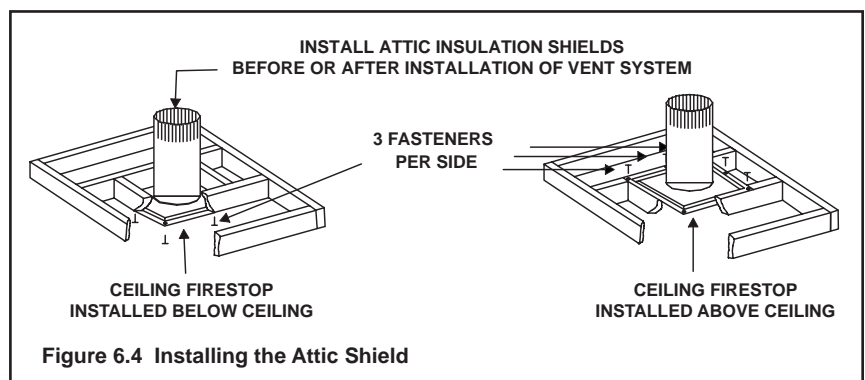
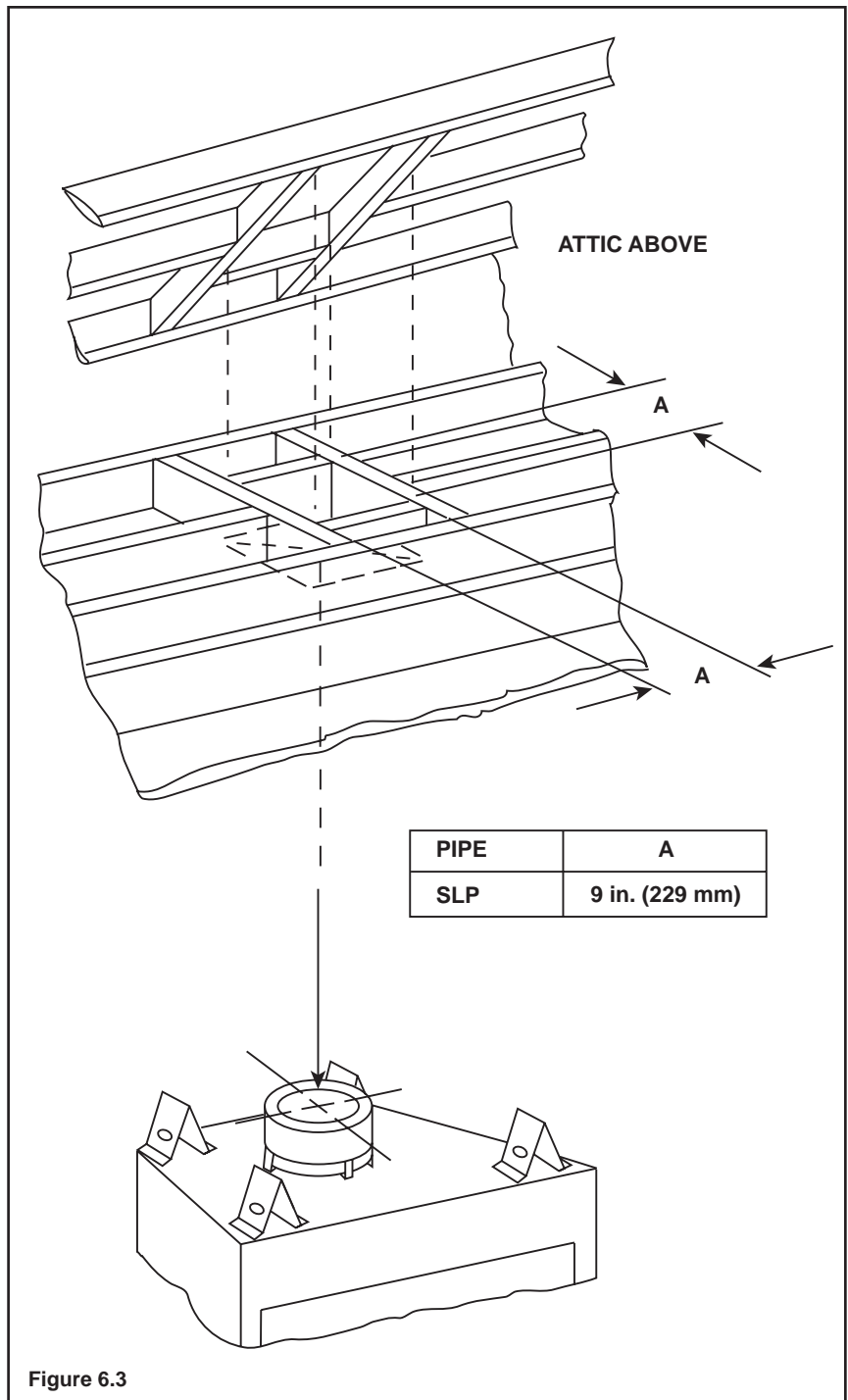

D. Install Attic Insulation Shield

WARNING! Fire Risk. DO NOT allow loose materials or insulation to touch vent. Hearth & Home Technologies Inc. requires the use of an attic shield.

The National Fuel Gas Code ANSI Z223.1 and NFPA 54 requires an attic shield constructed of 26 gauge minimum metal that extends at least 2 in. (51 mm) above insulation.

Attic shields must meet specified clearance and be secured in place.

Flat Ceiling Installation

- Remove one shield from box.

NOTICE: Cut previously installed batt insulation to make room for the attic insulation shield.

- Wrap shield around pipe if pipe is already installed in area to be insulated.
- Match the three holes in each side and fasten with three screws to form a tube.
- Bend three tabs on the bottom of the shield outward to allow attachment to the ceiling firestop.
- Bend the remaining bottom tabs inward 90° to maintain the air space between the pipe and the shield. Set the shield on the ceiling firestop and attach to the firestop.
- Bend all tabs inward 90° around the top of the shield. These tabs must be used to prevent blown insulation from getting between the shield and vent pipe, and to maintain air space clearance.

Vaulted Ceiling Installation

- The attic insulation shield has been laser-etched with cut lines and ceiling pitches to make field trimming easier.
- Remove one shield from box.

NOTICE: Cut previously installed batt insulation to make room for the attic insulation shield.

- Cut the attic insulation shield (if application is for vaulted ceiling) using a laser-etched cut line, to fit your ceiling pitch. Snip cut edge to recreate 1 in. bend tabs all the way around the bottom.
- Wrap shield around pipe if pipe is already installed in area to be insulated.
- Match the three holes in each side and fasten with three screws to form a tube.
- Bend three tabs on the bottom of the shield outward to allow attachment to the ceiling firestop.
- Bend the remaining bottom tabs inward 90° to maintain the air space between the pipe and the shield. Set the shield on the ceiling firestop and attach to the firestop.
- Bend all tabs inward 90° around the top of the shield. These tabs must be used to prevent blown insulation from getting between the shield and vent pipe, and to maintain air space clearance.

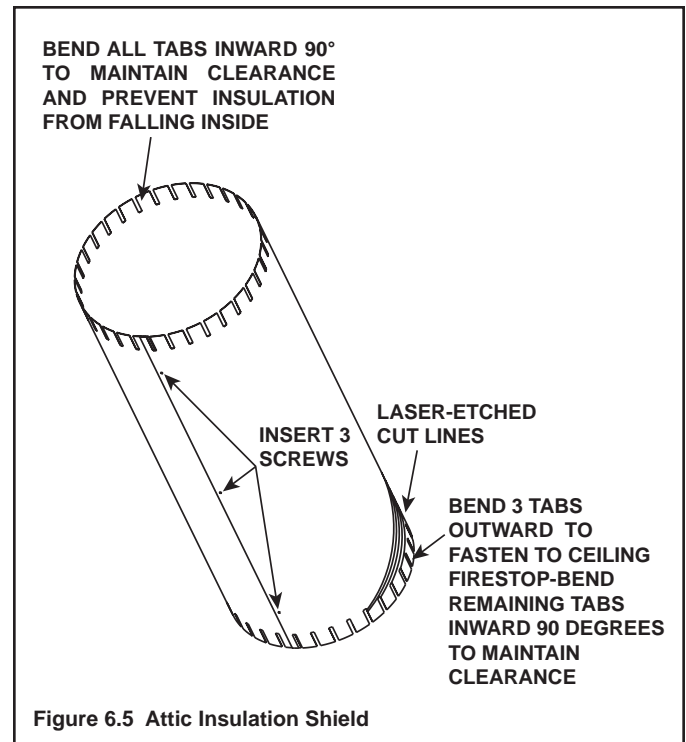

Figure 6.5 Attic Insulation Shield

7 Appliance Preparation

A. Top Vent



Figure 7.1 Remove the cover plate by removing the four screws holding it to the top of the appliance. Remove and discard the cover plate.

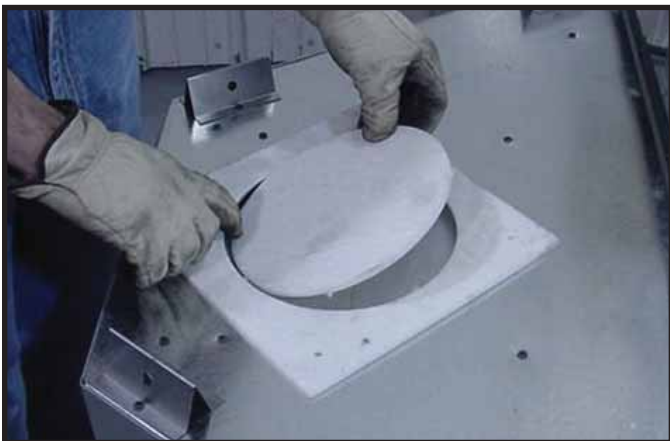

Figure 7.2 Remove the center insulation plug.



Figure 7.3 Cut the metal retaining band and fold the sides out.



Figure 7.4 Fold the center parts of the retaining band up and use to remove the vent cap.



Figure 7.5 Discard the vent cap, remove and discard the insulation basket. Note: Once the vent cap has been removed it cannot be reattached.

Proceed to Section 7. C.

CAUTION	
	Sharp Edges
	• Wear protective gloves and safety glasses during installation.
	

Note: Actual fireplace top appearance may be different from pictures shown above.

B. Securing and Leveling the Appliance

WARNING



Fire Risk.

- Prevent contact with sagging, loose insulation.
- Do NOT install against combustible materials such as exposed insulation, plastic and insulation backer.

The diagram shows how to properly position, level, and secure the appliance (see Figure 7.6). Nailing tabs are provided to secure the appliance to the framing members.

- Venting - refer to Vent Clearances and Framing (Section 6) for hole location.
- Place the appliance into position.
- Level the appliance from side to side and front to back.
- Shim the appliance as necessary. It is acceptable to use wood shims.
- Bend out nailing tabs on each side.
- Keep nailing tabs flush with the framing.
- Secure the appliance to the framing by using nails or screws through the nailing tabs.

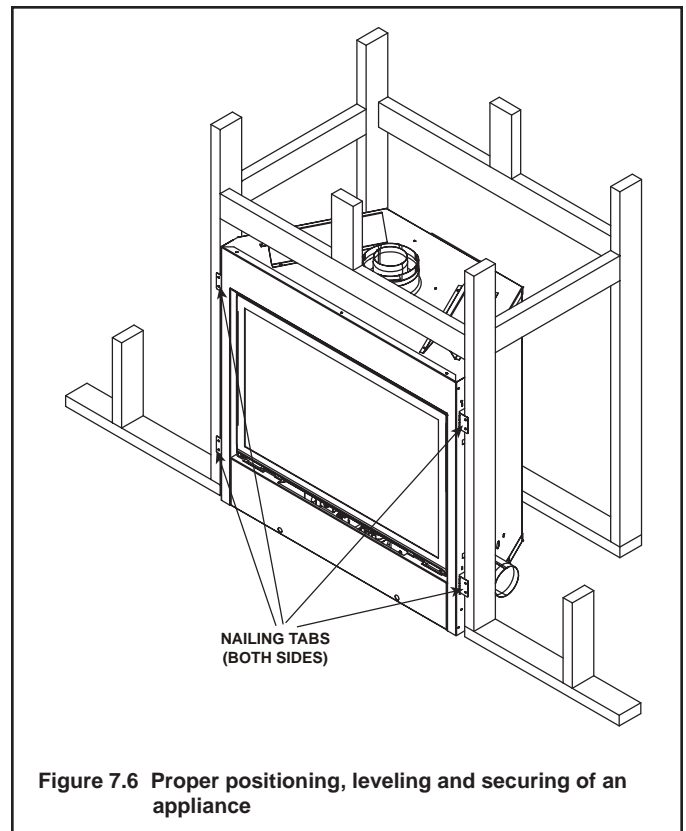

Figure 7.6 Proper positioning, leveling and securing of an appliance

WARNING

Fire Risk.

- ALWAYS maintain specified clearances around the appliance.
 - Do NOT notch into the framing around the appliance spacers.
- Failure to keep insulation, framing or other material away from the appliance may cause fire.



8 Installing Vent Pipe

A. Assemble Vent Sections

To attach the first vent component to the starting collars of the appliance:

- Lock the vent components into place by sliding the pipe section onto the collar.
- Align the seam of the pipe and seam of collar to allow engagement. Rotate the vent component to lock into place. Use this procedure for all vent components. See Figure 8.1.
- Slide the gasket over the first vent section and place it flush to the appliance. This will prevent cold air infiltration. High temperature caulk may be used to hold the part in place.
- Continue adding vent components, locking each succeeding component into place.
- Ensure that each succeeding vent component is securely fitted and locked into the preceding component.

Commercial, Multi-family (Multi-level exceeding two stories), or High-Rise Applications

For Installation into a commercial, multi-family (multi-level exceeding two stories) or high-rise applications: All outer pipe joints must be sealed with high temperature silicone, including the slip section that connects directly to the horizontal termination cap.

- Apply a bead of silicone sealant inside the female outer pipe joint prior to joining sections. See Figure 8.2
- Only outer pipes need to be sealed. All unit collar, pipe, slip section, elbow and cap outer flues shall be sealed in this manner, unless otherwise stated.

WARNING! Risk of Fire or Explosion! DO NOT break silicone seals on slip sections. Use care when removing termination cap from slip pipe. If slip section seals are broken during removal of the termination cap, vent may leak.

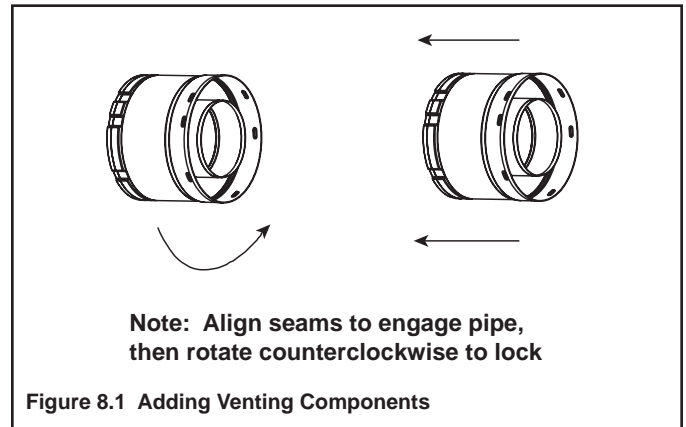

Figure 8.2 High Temperature Silicone Sealant

B. Assemble Slip Sections

- Slide the inner flue of the slip section into the inner flue of the pipe section and the outer flue of the slip section over the outer flue of the pipe section. See Figure 8.3.
- Slide together to the desired length.

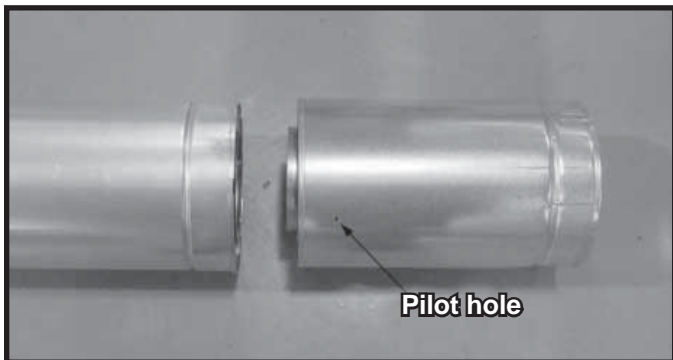

Figure 8.3 Slip Section Pilot Holes

- Maintain a 1-1/2 in. (38 mm) overlap between the slip section and the pipe section.
- Secure the pipe and slip section with two screws no longer than 1/2 in. (13 mm), using the pilot holes in the slip section. See Figure 8.4.

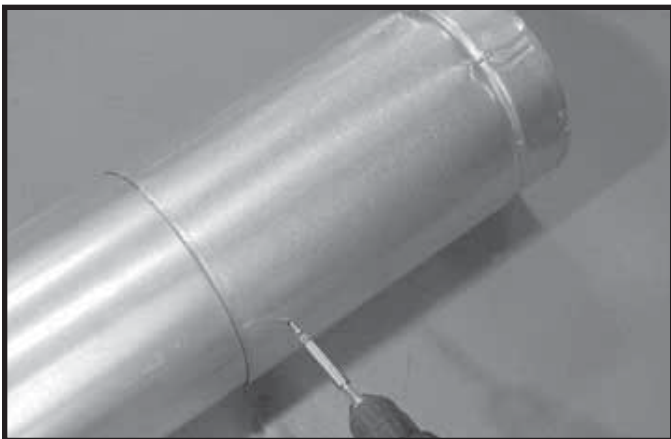

Figure 8.4 Screws into Slip Section

- Continue adding pipe as necessary following instructions in “Assembling Pipe Sections.”

NOTICE: If slip section is too long, the inner and outer flues of the slip section can be cut to the desired length.

NOTICE: When installing a vent system with an HRC termination cap, all pipe system joints shall be sealed using a high temperature silicone sealant.

- Apply a bead of silicone sealant inside the female outer pipe joint prior to joining sections.
- Only outer pipes are sealed, sealing the inner flue is not required.
- All unit collar, pipe, slip section, elbow and cap outer flues shall be sealed.

C. Secure the Vent Sections

- Vertical runs of SLP pipe must be supported every 8 ft. (2.44 m).
- Horizontal sections must be supported every 5 feet (1.52 m).
- Vent supports or plumbers strap (spaced 120° apart) may be used to support. See Figures 8.5 and 8.6.
- Wall shield firestops may be used to provide horizontal support.
- SLP ceiling firestops have tabs that may be used to provide vertical support.

WARNING! Risk of Fire, Explosion or Asphyxiation! Improper support may allow vent to sag and separate. Use vent run supports and connect vent sections per installation instructions. DO NOT allow vent to sag below connection point to appliance.

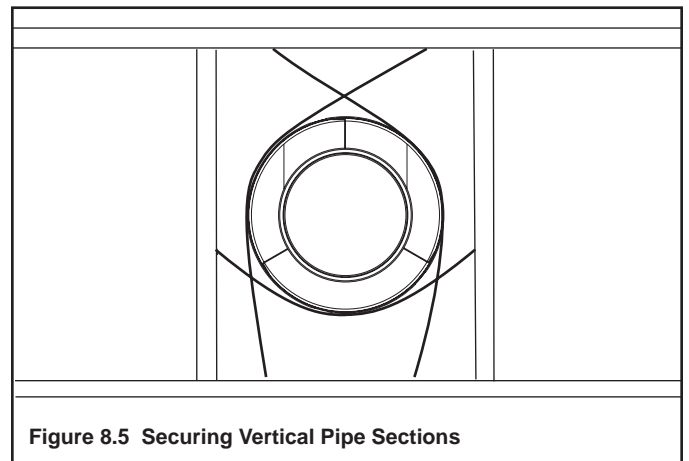

Figure 8.5 Securing Vertical Pipe Sections

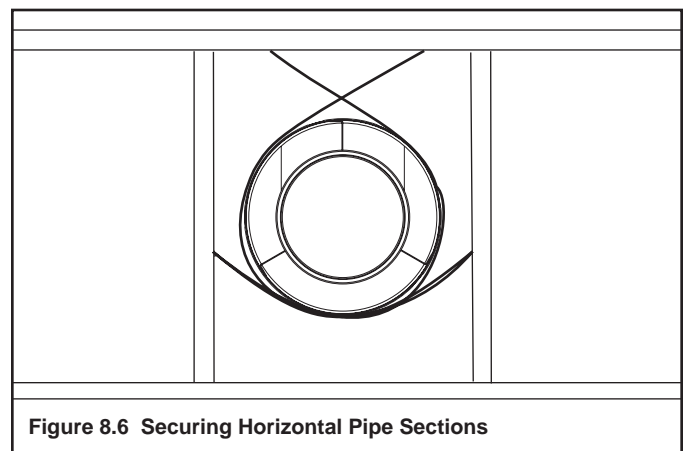

Figure 8.6 Securing Horizontal Pipe Sections

D. Disassemble Vent Sections

- Rotate either section (see Figure 8.7) so the seams on both pipe sections are aligned as shown in Figure 8.8.
- Pull carefully to separate the pieces of pipe.

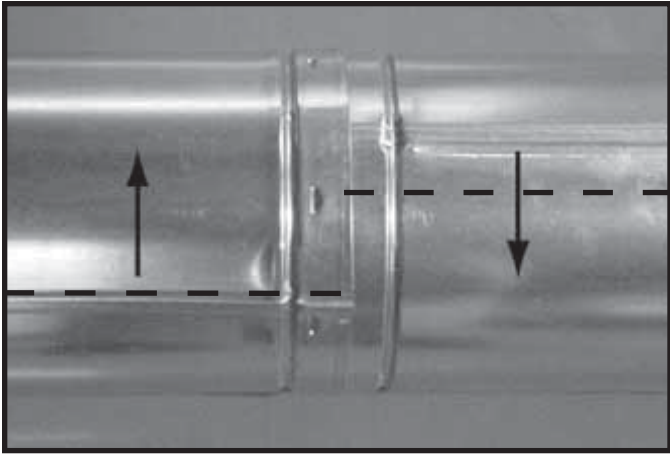

Figure 8.7 Rotate Seams for Disassembly

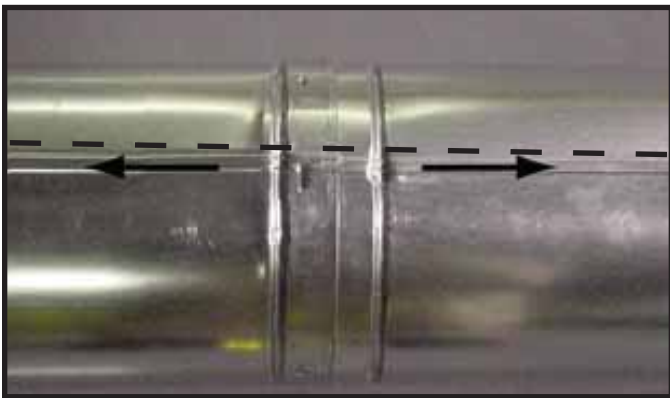

Figure 8.8 Align and Disassemble Vent Sections

E. Install Decorative Ceiling Components

A decorative ceiling thimble can be installed on a flat ceiling through which the vent passes. The decorative ceiling thimble is used to cover the firestop.

- Seal the gap between the vent pipe and firestop using high temperature silicone to prevent cold air infiltration.
- Install the decorative ceiling thimble by sliding it up to the ceiling and attaching it using the provided screws.

A decorative cathedral ceiling support box can be installed on a cathedral ceiling through which the vent passes.

- Use a plumb-bob to mark the center line of the venting system on the ceiling and drill a small hole through the ceiling and roof at this point. Locate the hole and mark the outline of the cathedral ceiling support box on the outside roof.
- Remove shingles or other roof covering as necessary to cut the rectangular hole for the support box. Cut the hole 1/8 in. (3 mm) larger than the support box outline.

- Lower the support box through the hole in the roof until its bottom is at least 2 in. (51 mm) below the ceiling (Figure 8.9).
- Level the support box both vertically and horizontally and temporarily tack it in place through the inside walls into the roof sheathing.
- Use tin snips to cut the support box from the top corners down to the roof line and fold the resulting flaps to the roof. See Figure 8.10.
- Nail the flaps to the roof AFTER running a bead of non hardening sealant between the flaps and the roof.

WARNING! Risk of Fire! Clean out ALL materials from inside the support box and complete the vertical vent run and termination.

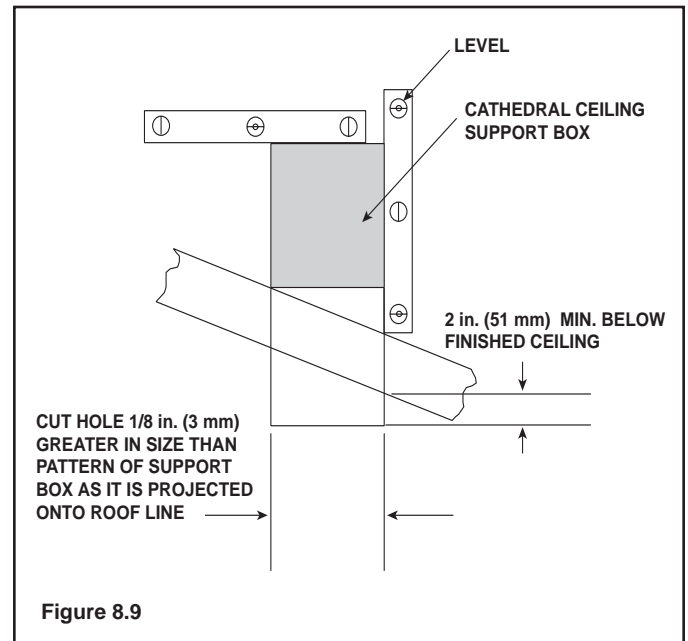

Figure 8.9

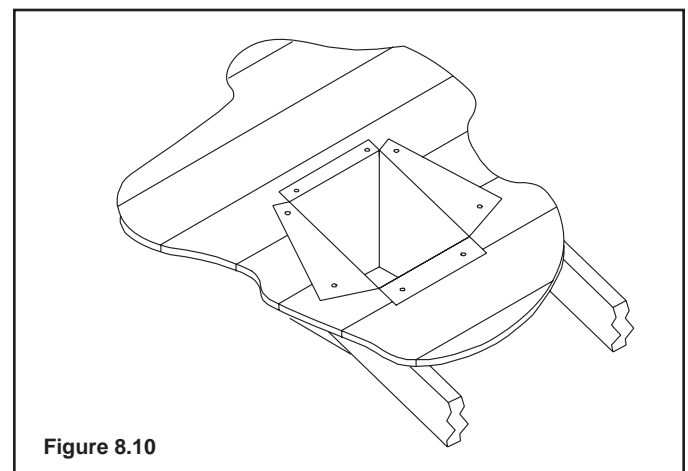
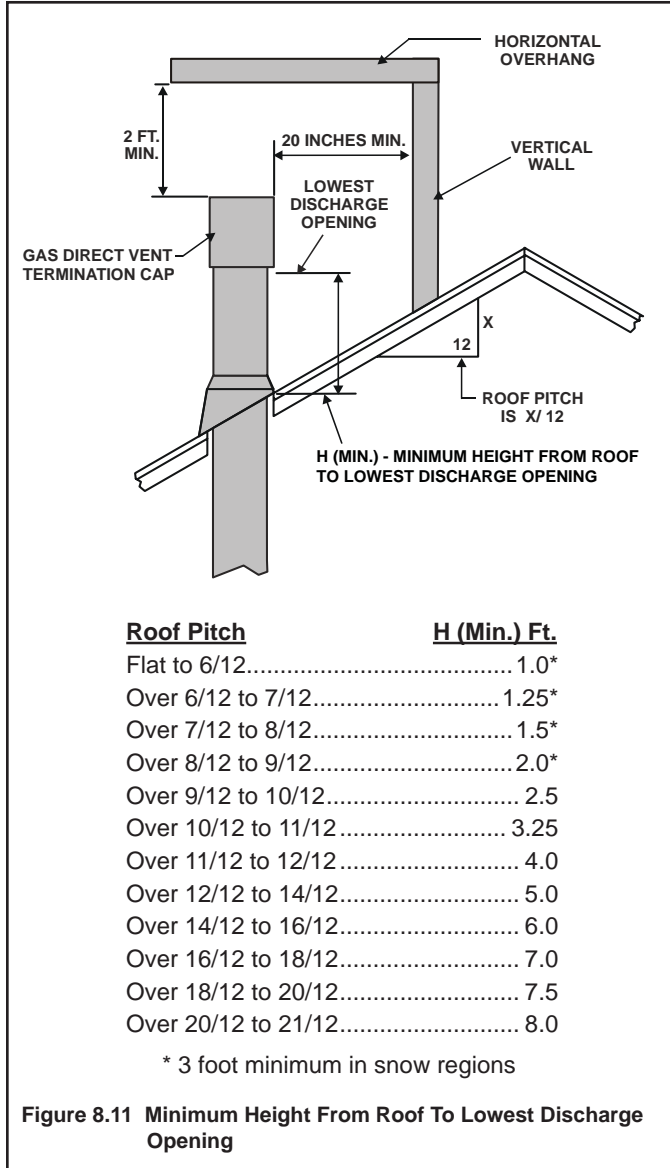

Figure 8.10

F. Install Metal Roof Flashing

- See minimum vent heights for various pitched roofs (Figure 8.11) to determine the length of pipe to extend through the roof.
- Slide the roof flashing over the pipe sections extending through the roof as shown in Figure 8.12.



NOTICE: Failure to properly caulk the roof flashing could cause water entry.

- Caulk the gap between the roof flashing and the outside diameter of the pipe.
- Caulk the perimeter of the flashing where it contacts the roof surface. See Figure 8.12.

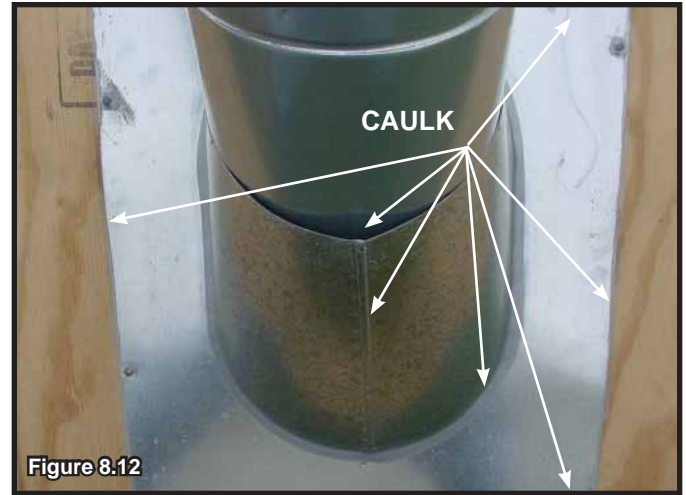

G Assemble and Install Storm Collar

CAUTION! Risk of Cuts, Abrasions or Flying Debris. Wear protective gloves and safety glasses during installation. Sheet metal edges are sharp.

- Connect both halves of the storm collar with two screws (see Figure 8.13).
- Wrap the storm collar around the exposed pipe section closest to the roof and align brackets. Insert a bolt (provided) through the brackets and tighten the nut to complete the storm collar assembly. Make sure the collar is tight against the pipe section.
- Slide the assembled storm collar down the pipe section until it rests on the roof flashing (see Figure 8.14).
- Caulk around the top of the storm collar (see Figure 8.20).

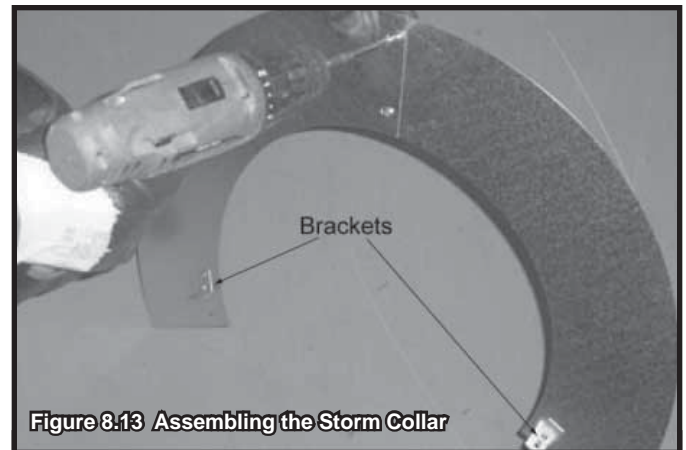

H. Install Vertical Termination Cap

- Attach the vertical termination cap by sliding the inner collar of the cap into the inner flue of the pipe section while placing the outer collar of the cap over the outer flue of the pipe section.
- Secure the cap by driving three self-tapping screws (supplied) through the pilot holes in the outer collar of the cap into the outer flue of the pipe (see Figure 8.20).



Figure 8.20

I. Install Decorative Wall Components

A decorative wall thimble can be installed on wall through which the vent passes. The decorative wall thimble is used to cover the wall shield firestop.

- Slide the decorative wall thimble over the last section of horizontal pipe before connecting the termination cap to the pipe.
- Once the pipe section and the termination cap have been connected, slide the wall thimble up to the interior wall surface and attach with screws provided. See Figure 8.21.

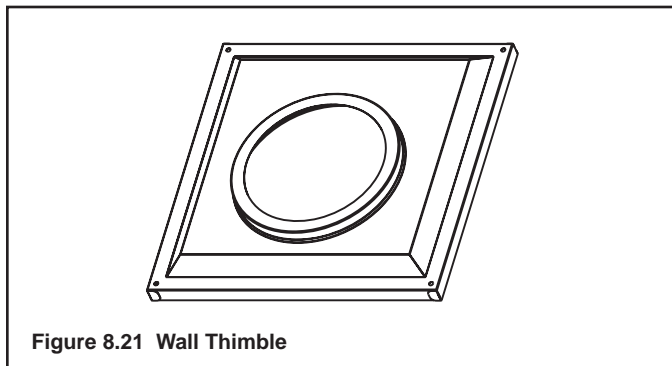

Figure 8.21 Wall Thimble

J. Heat Shield Requirements for Horizontal Termination

WARNING! Risk of Fire! To prevent overheating and fire, heat shields must extend through the entire wall thickness.

- **DO NOT** remove the heat shields attached to the wall shield firestop and the horizontal termination cap (shown in Figure 8.21).
- Heat shields must overlap 1-1/2 in. (38 mm) minimum.

There are two sections of the heat shield. One section is factory-attached to the wall shield firestop. The other section is factory-attached to the cap. See Figure 8.25.

If the wall thickness does not allow the required 1-1/2 in. (38 mm) heat shield overlap when installed, an extended heat shield must be used.

- If the wall thickness is less than 4-3/8 in. (111 mm), the heat shields on the cap and wall shield firestop must be trimmed. A minimum 1-1/2 in. (38 mm) overlap **MUST** be maintained.
- Use an extended heat shield if the finished wall thickness is greater than 7-1/4 in. (184 mm).
- The extended heat shield may need to be cut to length maintaining sufficient length for a 1-1/2 in. (38 mm) overlap between heat shields.
- Attach the extended heat shield to either of the existing heat shields using the screws supplied with the extended heat shield. Refer to vent components diagrams in the back of this manual.
- Rest the small leg on the extended heat shield on top of the pipe section to properly space it from the pipe section.

Important Notice: Heat shields may not be field constructed.

K. Install Horizontal Termination Cap

WARNING! Risk of Fire! The telescoping flue section of the termination cap **MUST** be used when connecting vent.

- 1-1/2 (38 mm) minimum overlap of flue telescoping section is required.

Failure to maintain overlap may cause overheating and fire.

- Vent termination must not be recessed in the wall. Siding may be brought to the edge of the cap base.
- Flash and seal as appropriate for siding material at outside edges of cap.
- When installing a horizontal termination cap, follow the cap location guidelines as prescribed by current **ANSI Z223.1** and **CAN/CGA-B149** installation codes and refer to Section 6 of this manual.

CAUTION! Risk of Burns! Local codes may require installation of a cap shield to prevent anything or anyone from touching the hot cap.

NOTICE: For certain exposures which require superior resistance to wind-driven rain penetration, a flashing kit and HRC caps are available. When penetrating a brick wall, a brick extension kit is available for framing the brick.

Note: When using termination caps with factory-supplied heat shield attached, no additional wall shield firestop is required on the exterior side of a combustible wall.

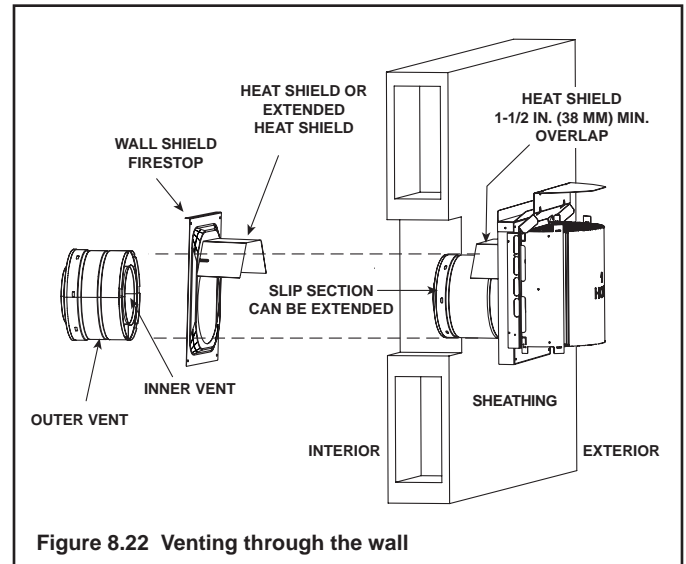

Figure 8.22 Venting through the wall

9 Gas Information

A. Fuel Conversions

Before making gas connections ensure that appliance being installed is compatible with the available gas type.

Any natural or propane gas conversions necessary to meet the appliance and locality needs must be made by a qualified technician using Hearth & Home Technologies specified and approved parts.

B. Gas Pressures

Proper input pressures are required for optimum appliance performance. Gas line sizing requirements need to be made following NFPA54.

⚠ WARNING



Fire Risk.
Explosion Hazard.
High pressure will damage valve.

- Disconnect gas supply piping BEFORE pressure testing gas line at test pressures above 1/2 psig.
- Close the manual shutoff valve BEFORE pressure testing gas line at test pressures equal to or less than 1/2 psig.

⚠ WARNING



Verify inlet pressures.

- High pressure may cause overfire condition.
- Low pressure may cause explosion.
- Verify minimum pressures when other household gas appliances are operating.

Install regulator upstream of valve if line pressure is greater than 1/2 psig.

Pressure requirements for appliance are shown in the table below. Minimum pressures must be met when other household gas appliances are operating.

Pressure	Natural Gas	Propane
Minimum inlet pressure	5.0 inches w.c.	11.0 inches w.c.
Maximum inlet gas pressure	14.0 inches w.c.	14.0 inches w.c.
Manifold pressure	3.5 inches w.c.	10.0 inches w.c.

C. Gas Connection

Note: Have the gas supply line installed in accordance with local building codes, if any. If not, follow ANSI 223.1. Installation should be done by a qualified installer approved and/or licensed as required by the locality. (In the Commonwealth of Massachusetts installation must be performed by a licensed plumber or gas fitter).

Note: A listed (and Commonwealth of Massachusetts approved) 1/2 inch (13 mm) T-handle manual shut-off valve and flexible gas connector are connected to the 1/2 inch (13 mm) control valve inlet.

- **If substituting for these components, please consult local codes for compliance.**

Refer to **Reference Section 16** for location of gas line access in appliance.

Note: Gas line may be run from either side of the appliance provided the hole in the outer wrap does NOT exceed 2-1/2 inches in diameter and does not penetrate the firebox.

⚠ WARNING





Gas Leak Risk



- Support control when attaching pipe to prevent bending gas line.

Note: The gap between supply piping and gas access hole may be caulked with high temperature caulk or stuffed with non-combustible, unfaced insulation to prevent cold air infiltration.

- Ensure that gas line does not come in contact with outer wrap of appliance. Follow local codes.
- Incoming gas line should be piped into the valve compartment and connected to the 1/2 inch connection on the manual shutoff valve.

⚠ WARNING	
	<p>Fire or Explosion Hazard</p> <ul style="list-style-type: none"> • Gas buildup during line purge may ignite. • Purge should be performed by qualified technician. • Ensure adequate ventilation. • Ensure there are no ignition sources such as sparks or open flames.
	

- A small amount of air will be in the gas supply lines. When first lighting appliance it will take a short time for air to purge from lines. When purging is complete the appliance will light and operate normally.

⚠ WARNING	
	<p>CHECK FOR GAS LEAKS</p> <p>Explosion Risk Fire Risk Asphyxiation Risk</p> <ul style="list-style-type: none"> • Check all fittings and connections. • Do not use open flame. • After the gas line installation is complete, all connections must be tightened and checked for leaks with a commercially-available, non-corrosive leak check solution. Be sure to rinse off all leak check solution following testing.
	<p>Fittings and connections may have loosened during shipping and handling.</p>

⚠ WARNING	
	<p>Fire hazard.</p> <p>Do NOT change the valve settings.</p> <ul style="list-style-type: none"> • This valve has been preset at the factory. • Changing valve settings may result in fire hazard or bodily injury.

<p>HIGH ALTITUDE INSTALLATIONS</p> <p>U.L. Listed gas appliances are tested and approved without requiring changes for elevations from 0 to 2000 feet in the U.S.A. and Canada.</p> <p>When installing this appliance at an elevation above 2000 feet, it may be necessary to decrease the input rating by changing the existing burner orifice to a smaller size. Input rate should be reduced by 4% for each 1000 feet above a 2000 foot elevation in the U.S.A., or 10% for elevations between 2000 and 4500 feet in Canada. If the heating value of the gas has been reduced, these rules do not apply. To identify the proper orifice size, check with the local gas utility.</p> <p>If installing this appliance at an elevation above 4500 feet (in Canada), check with local authorities.</p>
--

10 Electrical Information

A. Recommendation for Wire

This appliance requires that continuous 110-120 VAC be wired to the factory installed junction box. Maintain correct polarity when wiring the junction box. See wiring diagram for details.

B. Optional Accessories



Optional remote control kits can be used with this product. The remote control receiver should be placed on the floor of the valve area in a convenient location keeping in mind that service will be performed through the inner access panel. For the WSK-MLT (Intellifire) kit follow Figure 10.3.

A wall switch is provided and is recommended even if a remote control is installed. The wall switch is 110-120VAC and requires appropriate wire be used. A junction box should be used for the wire connections. See wiring diagram for details.

Note: This appliance must be electrically wired and grounded in accordance with local codes or, in the absence of local codes, with **National Electric Code ANSI/NFPA 70-latest edition** or the **Canadian Electric Code, CSA C221.1**.

- A 110-120 VAC circuit for this product must be protected with ground-fault circuit-interrupter protection, in compliance with the applicable electrical codes, when it is installed in locations such as in bathrooms or near sinks.

C. Connecting to the Appliance

	⚠ WARNING
	Wire 110V to electrical junction box. Do NOT wire 110V to valve. Do NOT wire 110V to the WSK-MLT wall control.
	<ul style="list-style-type: none">• Incorrect wiring will damage millivolt valves.• Incorrect wiring will override IPI safety lockout and may cause explosion.

- This appliance may be used with a wall switch, wall mounted thermostat and/or a remote control.
- If using thermostat use one compatible with a millivolt gas valve system.
- Follow parameters for locating thermostat (see individual thermostat instructions) to ensure proper operation of appliance.
- Use low resistance thermostat wire for wiring from the WSK-MLT to the WSK-MLT wall control.
- Keep wire lengths short as possible by removing any excess wire length.
- Low voltage and 110 VAC voltage cannot be shared within the same wall box.

D. Intellifire Ignition System Wiring

This appliance requires a 110 VAC supply to the appliance junction box for operation. A wiring diagram is shown in Figure 10.1.

This appliance is equipped with an Intellifire control valve which operates on a 3 volt system.

Optional Accessories Requirements

Wiring for optional accessories should be done now to avoid reconstruction.

Note: Battery powered remote control receivers are not approved for use with this product.

CAUTION

Label all wires prior to disconnection when servicing controls. Wiring errors can cause improper and dangerous operation. Verify proper operation after servicing.



⚠ WARNING

Shock hazard.

- Replace damaged wire with type 105° C rated wire.
- Wire must have high temperature insulation.

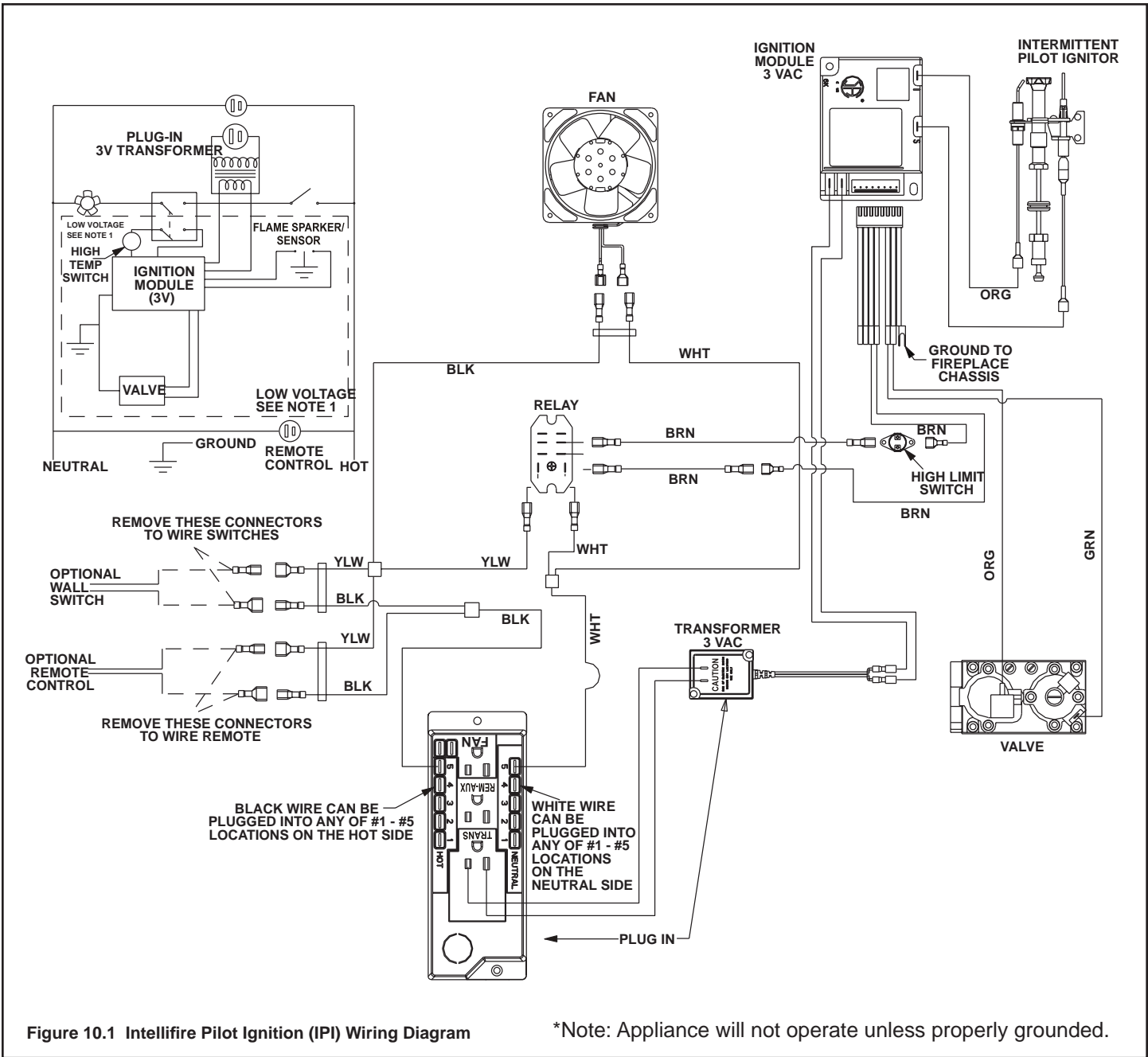

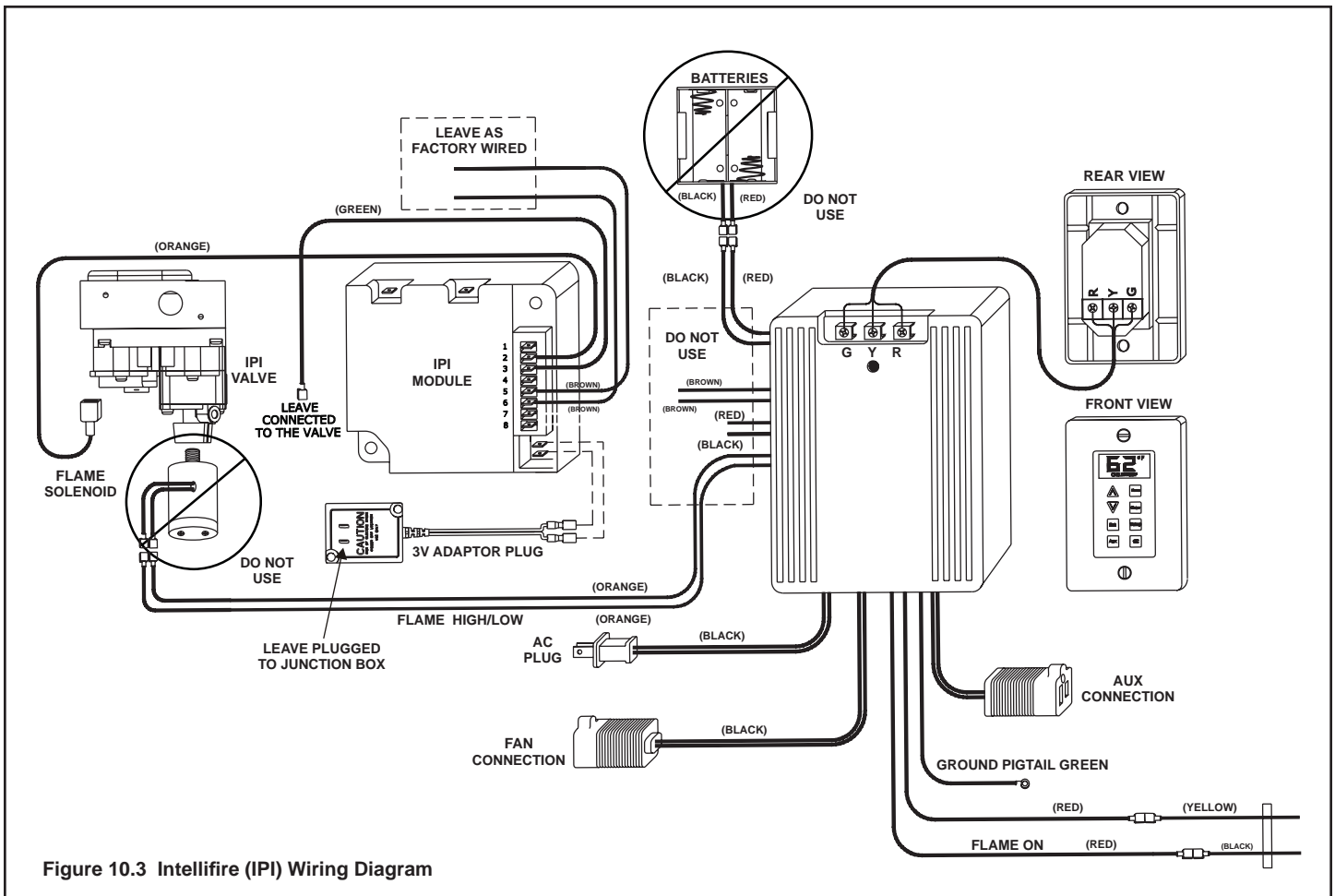

E. Junction Box Installation

If the box is being wired from the **INSIDE** of the appliance:

- Remove screws that secure junction box to cover plate.
- Loosen the screw on the Romex connector, feed the necessary length of wire through the connector and tighten the screw.
- Pull the electrical wires from outside the appliance through this opening into the valve compartment.
- Make all necessary wire connections to the receptacle and assemble the receptacle and cover to the junction box.

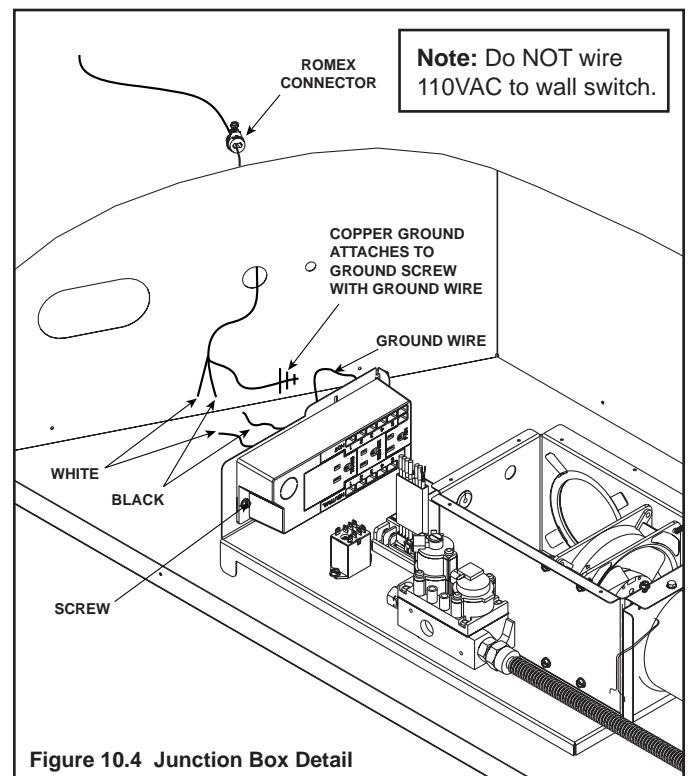

11 Finishing

A. Mantel Projections

Figure 11.1 shows the minimum vertical and corresponding maximum horizontal dimensions of appliance mantels or other combustible projections above the top front edge of the appliance.

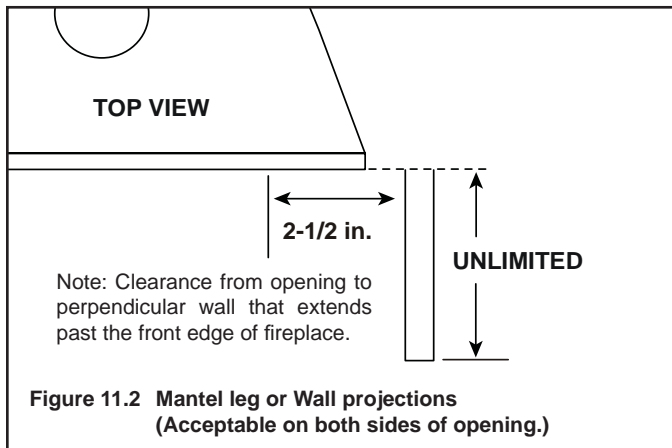
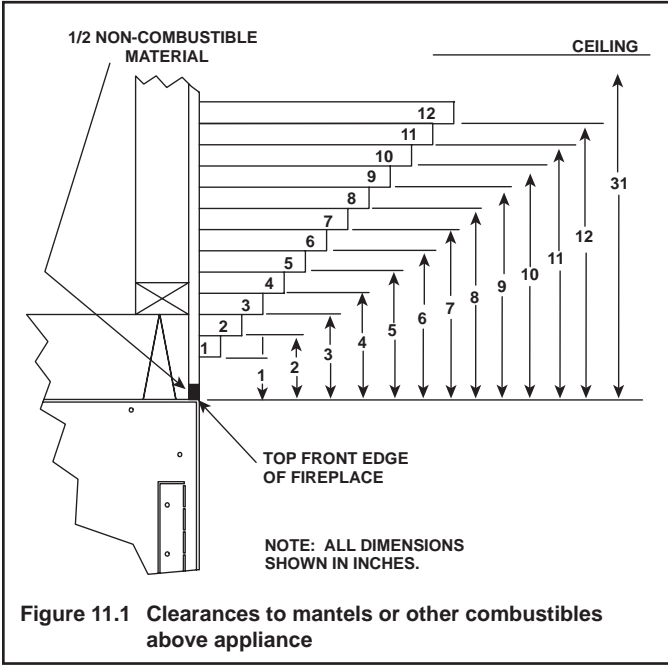

B. Facing Material

⚠ WARNING

Fire Risk.
Do NOT obstruct air inlet or outlet grilles.
Do NOT modify grilles.

- Modifying or covering grilles could cause temperature rise and fire hazard.

Finishing materials must not interfere with:

- Air flow through grilles or louvers.
- Operation of louvers or doors.
- Access for service.

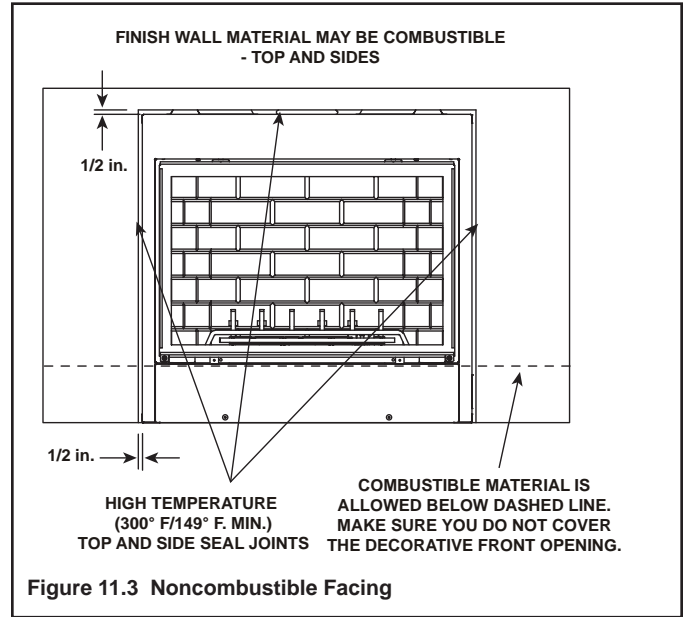

C. Flooring Considerations

If the fireplace is to be installed prior to finished floor construction (i.e. tile, carpet, etc.) in front of the fireplace, provisions must be made to accommodate for the difference in height between the floor underneath the fireplace and the finished floor to be installed in front of the fireplace.

⚠ WARNING

Risk of Fire

- Non-combustible clearances **MUST** be maintained.
- Sheetrock, wood or other combustibles must **NOT** be used as sheathing or facing in the non-combustible zone.
- See **Section 11** for proper clearances.
- See **Section 1** for combustible/non-combustible definitions.

⚠ WARNING

Fire Risk.

Finish all edges and fronts to clearances and specifications listed in manual.

- Black metal appliance front may be covered with noncombustible material only.
- Do NOT overlap combustible materials onto appliance front.
- Install combustible materials only up to specified clearances on top, front and side.
- Seal joints between the finished wall and appliance top and sides using only a 300° F minimum sealant.

12 Appliance Setup

A. Remove Shipping Materials

Remove shipping materials from inside or underneath the firebox.

B. Clean the Appliance

Clean/vacuum any sawdust that may have accumulated inside the firebox or underneath in the control cavity.

C. Accessories

Install approved accessories per instructions included with accessories. See Service Parts List for appropriate accessories. Refer to **Section 16**.

	⚠ WARNING Shock or fire risk. Use ONLY optional accessories approved for this appliance.
	<ul style="list-style-type: none">• Using non-listed accessories voids warranty.• Using non-listed accessories may result in a safety hazard.• Only Hearth & Home Technologies approved accessories may be used safely.

D. Pilot Air Deflector and Grate

The air deflector shield and grate are not factory installed and will need to be installed before operating the fireplace. The air deflector is installed behind the burner with the three small tabs resting on the rear burner surface. The back of the air deflector should touch the back of the firebox. The square cut-outs in the air deflector go around the rear grate legs. See figure 12.1.

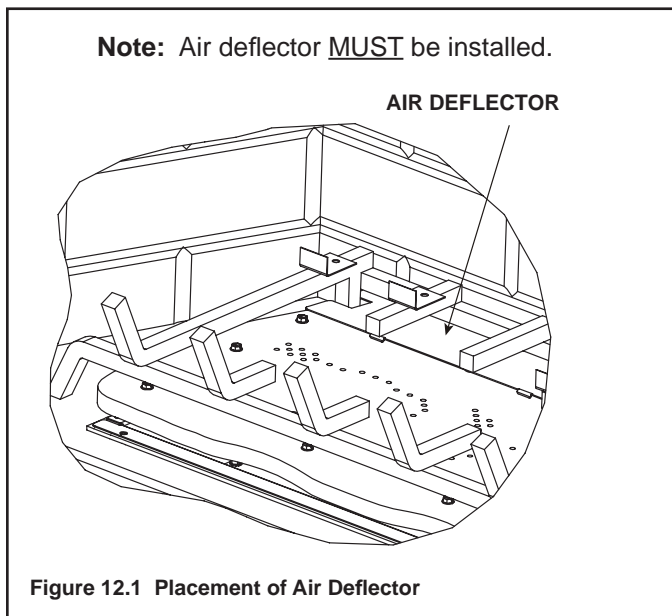

E. Lava Rock, Vermiculite, Rockwool/Ember Placement

⚠ WARNING	
	<p>Explosion Risk.</p> <ul style="list-style-type: none">• Follow ember placement instructions in manual.• Do NOT place embers directly over burner ports.• Replace ember material annually. <p>Improperly placed embers interfere with proper burner operation.</p>

Placing the Ember Material

Ember material is shipped with this gas appliance. To place the ember material:

- Embers **CANNOT** be placed directly over ports. Care should be taken not to cover the lighting trail of ports (from back to front).
- When placing Glowing Embers® onto the burner care should be taken so that the ports are not covered. Place the dime-size ember pieces just in front of the port trail, but not on or in between the ports. Failure to follow this procedure will likely cause lighting and sooting problems.
- Place Mystic Embers on areas of base refractory away from port holes. Use this material to give the appliance a realistic ash bed.
- Save the remaining ember materials for use during appliance servicing. The embers provided should be enough for 3 to 5 applications.

F. Positioning the Logs

Log Set Assembly: LOGS-INFINITY

CAUTION: Logs are fragile!
Carefully remove the logs from the packaging.

Place logs on a piece of cardboard as shown in Figure 1. The logs will be assembled in a similar orientation to their positions in Figure 1.

Note: Burner is shown white to improve contrast.

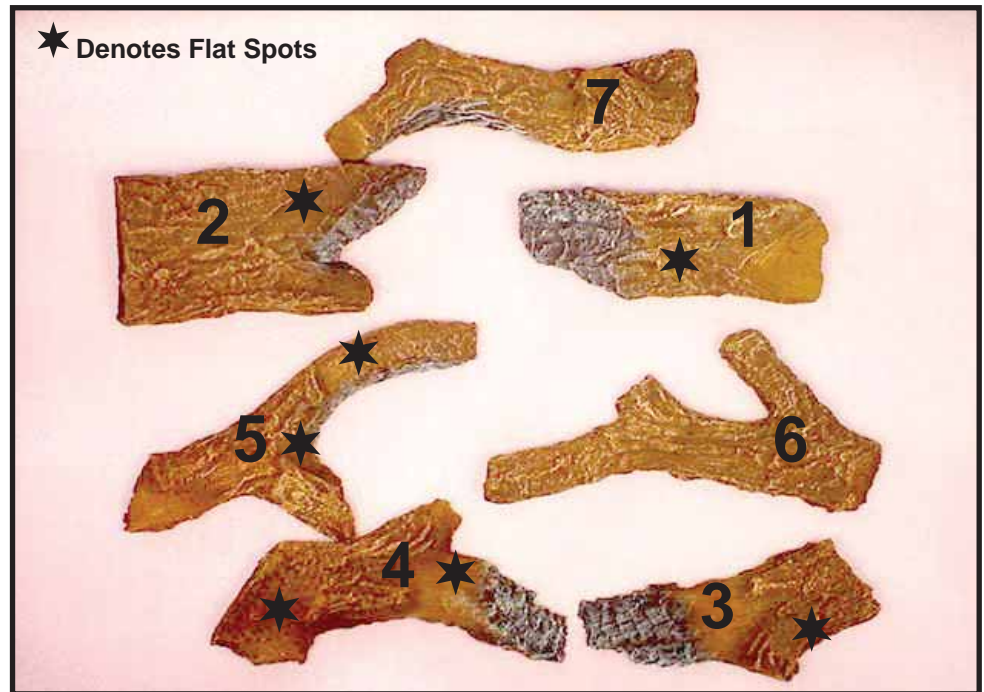

LOG #1 (SRV2003-702): Place log #1 on the back right of the grate. Place the two slots in the bottom of the log over the two tabs in the grate. The log may be slightly unstable at this time but will become more stable with the addition of the other logs.



LOG #2 (SRV2003-701): Place log #2 on the back left of the grate. Place the two slots in the bottom of the log over the two tabs in the grate.

2003-925 12/02

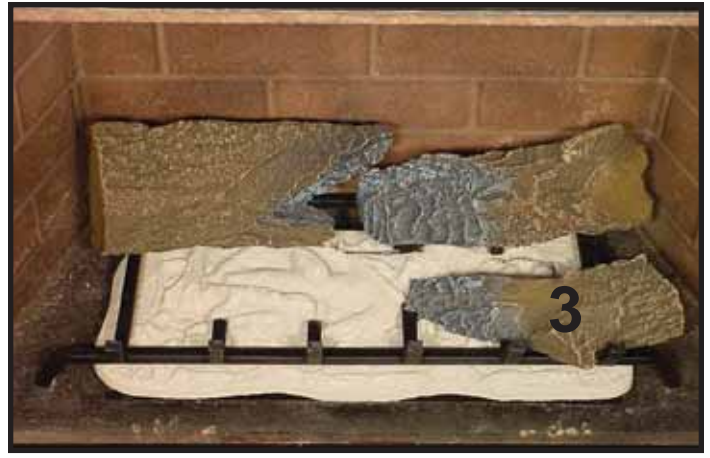

LOG #3 (SRV2003-704): Place log #3 on the front right of the grate. The two grooves on the bottom of the log and the narrow end of the log line up with the 1st, 2nd, and 3rd grate tines on the right of the grate.



LOG #4 (SRV2003-703): Place log #4 on the front left of the grate. The two grooves on the bottom of the log line up with the 2nd and 3rd tines on the left of the grate.



LOG #5 (SRV2003-705): Place the “Y” shaped log #5 on top of log #2 and log #4. The longer branch of log #5 sits on the flat spot on log #2 and the shorter branches sit on the two flat spots of log #4.

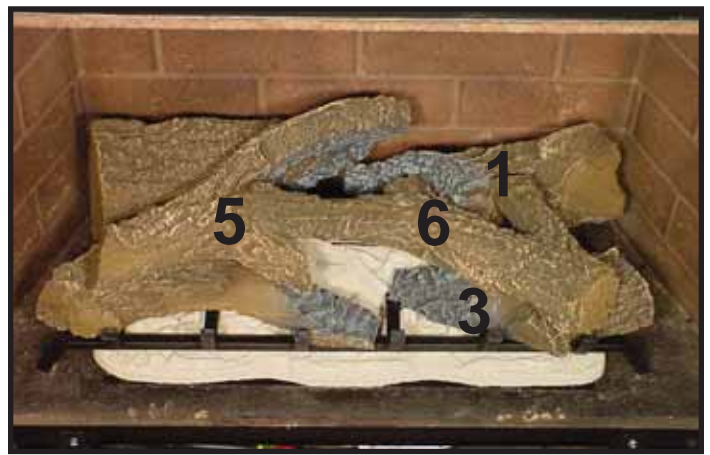

LOG #6 (SRV2003-706): Place log #6 on top of log #5, #1, and #3. The left end sits on the flat spot of log #5 and the right end sits on log #3. The “branch” rests on the flat spot of log #1.



LOG #7 (SRV780-707): Place log #7 on top of log #1 and #5. The left end rests on the long flat spot of log #5. The right end rests on the top of log #1 and rests against the “branch” of log #6.

G. Glass Assembly

⚠ WARNING

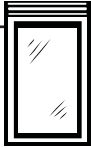

Handle glass doors with care.

- Inspect the gasket to ensure it is undamaged.
- Inspect the glass for cracks, chips or scratches.
- Do NOT strike, slam or scratch glass.
- Do NOT operate appliance with glass door removed, cracked, broken or scratched.
- Replace glass door assembly as a complete appliance.

Removing Glass Assembly

Remove the glass assembly on the unit by removing the two 1/4 inch screws at the top of the glass frame. Tip the top of the glass frame out and lift up to disengage the tabs at the bottom of the glass frame. See Figure 12.3.

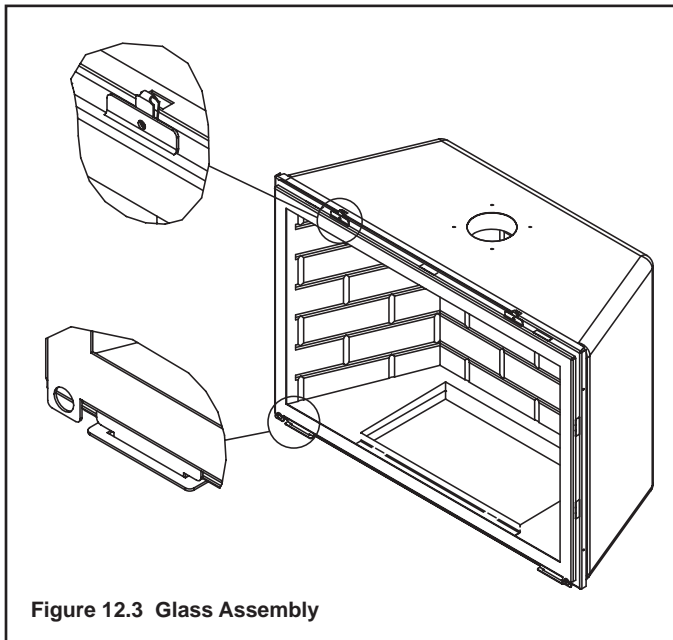

Figure 12.3 Glass Assembly

- The bottom front of the unit is removable for easier access to the valve. Remove the four screws holding the front access panel on. The lower screws are accessible by inserting a 1/4 inch nut driver through the 5/8 inch holes on the lower face of the access panel. After installation the access panel can be completely covered with non-combustible finishing material. Make sure the vertical opening for the door is greater than 23-3/4 inch before finishing over the access panel or the decorative door may not fit.

Note: When connecting the gas line, make sure the connection is close to the underside of the inner access panel. All after-installation service will have to be done through the inner access panel.

H. Grilles and Trim

Install optional marble and brass trim surround kits as desired. Marble, brass, brick, tile, or other noncombustible materials can be used to cover up the gap between the sheet rock and the appliance.

Install optional marble and brass trim surround kits as desired. Marble, brass, brick, tile, or other non-combustible materials can be used to cover up the gap between the sheet rock and the fireplace.

Note: When overlapping on both sides, leave enough space so decorative door is accessible.

I. Shutter Setting

	NG	LP
Burner	1/4 in.	Full Open



13 Operating Instructions

A. Before Lighting Appliance

The gas control system used with this model is an Intermittent Pilot Ignition (IPI). This system includes a 3V control valve, electronic module and intermittent pilot.

Before operating this appliance have a qualified technician:

- Remove all shipping materials from inside and/or underneath the firebox.
- Review proper placement of logs, rockwool, lava rock, and vermiculite.
- Check the wiring.
- Check the air shutter adjustment.
- Ensure that there are no gas leaks.
- Ensure that the glass is sealed and in the proper position.
- Ensure that the flow of combustion and ventilation air is not obstructed (front grilles and vent caps).

	WARNING
	<p>Glass door must be in place when appliance is operating.</p> <p>Risk of:</p> <ul style="list-style-type: none">• Combustion Fumes• Fire <p>Do NOT operate appliance with glass door removed.</p> <ul style="list-style-type: none">• Open viewing glass for servicing only. <ul style="list-style-type: none">• Glass door MUST be in place and sealed before operating appliance.• Only use glass door certified for use with appliance.• Glass replacement should be done by qualified technician.

WARNING	
	HOT SURFACES! Glass and other surfaces are hot during operation AND cool down.
	Hot glass will cause burns. <ul style="list-style-type: none">• DO NOT touch glass until it is cooled• NEVER allow children to touch glass• Keep children away
	<ul style="list-style-type: none">• CAREFULLY SUPERVISE children in same room as fireplace.• Alert children and adults to hazards of high temperatures.
	High temperatures may ignite clothing or other flammable materials. <ul style="list-style-type: none">• Keep clothing, furniture, draperies and other flammable materials away.
	<hr/> <p><i>This appliance has been supplied with an integral barrier to prevent direct contact with the fixed glass panel. DO NOT operate the appliance with the barrier removed.</i></p> <p>Contact your dealer or Hearth & Home Technologies if the barrier is not present or help is needed to properly install one.</p>

WARNING	
Improper installation, adjustment, alteration, service or maintenance can cause injury or property damage. Refer to the owner's information manual provided with this appliance. For assistance or additional information consult a qualified installer, service agency or the gas supplier.	

WARNING	
Do NOT use this appliance if any part has been under water. Immediately call a qualified service technician to inspect the appliance and to replace any part of the control system and any gas control which has been under water.	

→ B. Lighting Instructions (IPI)

The IPI system may be operated with two D-cell batteries. When using batteries, unplug the transformer. To prolong battery life, remove them when using the transformer.

FOR YOUR SAFETY READ BEFORE LIGHTING

WARNING: If you do not follow these instructions exactly, a fire or explosion may result causing property damage, personal injury or loss of life.

- A.** This appliance is equipped with an intermittent pilot ignition (IPI) device which automatically lights the burner. **DO NOT** try to light the burner by hand.
- B. BEFORE LIGHTING**, smell all around the appliance area for gas. Be sure to smell next to the floor because some gas is heavier than air and will settle on the floor.
- WHAT TO DO IF YOU SMELL GAS**
- **DO NOT** try to light any appliance.
 - **DO NOT** touch any electric switch; do not use any phone in your building.
- Immediately call your gas supplier from a neighbor's phone. Follow the gas supplier's instructions.
 - If you cannot reach your gas supplier, call the fire department.
- C. DO NOT** use this appliance if any part has been under water. Immediately call a qualified service technician to inspect the appliance and to replace any part of the control system and any gas control which has been under water.

WARNING:

DO NOT CONNECT LINE VOLTAGE (110/120 VAC OR 220/240 VAC) TO THE CONTROL VALVE.

Improper installation, adjustment, alteration, service or maintenance can cause injury or property damage. Refer to the owner's information manual provided with this appliance.

This appliance needs fresh air for safe operation and must be installed so there are provisions for adequate combustion and ventilation air.

If not installed, operated, and maintained in accordance with the manufacturer's instructions, this product could expose you to substances in fuel or fuel combustion which are known to the State of California to cause cancer, birth defects, or other reproductive harm.

Keep burner and control compartment clean. See installation and operating instructions accompanying appliance.

For additional information on operating your
Hearth & Home Technologies fireplace, please refer to www.fireplaces.com.

CAUTION:

Hot while in operation. **DO NOT** touch. Keep children, clothing, furniture, gasoline and other liquids having flammable vapors away.

DO NOT operate the appliance with fixed glass assembly removed, cracked or broken. Replacement of the fixed glass assembly should be done by a licensed or qualified service person.

NOT FOR USE WITH SOLID FUEL

For use with natural gas and propane. A conversion kit, as supplied by the manufacturer, shall be used to convert this appliance to the alternate fuel.

Also Certified for Installation in a Bedroom or a Bedsitting Room.

For assistance or additional information, consult a qualified installer, service agency or the gas supplier.

LIGHTING INSTRUCTIONS (IPI)

1. This appliance is equipped with an ignition device which automatically lights the burner. **DO NOT** try to light the burner by hand.

**GAS
VALVE**

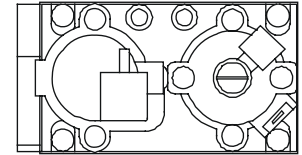

2. Wait five (5) minutes to clear out any gas. Then smell for gas, including near the floor. If you smell gas, **STOP!** Follow "B" in the Safety Information located on the left side of this label. If you do not smell gas, go to next step.
3. To light the burner:
Equipped with wall switch: Turn ON/OFF switch to ON.
Equipped with remote or wall control: Press ON or FLAME button.
Equipped with thermostat: Set temperature to desired setting.
4. If the appliance does not light after three tries, call your service technician or gas supplier.

TO TURN OFF GAS TO APPLIANCE

1. Equipped with wall switch: Turn ON/OFF switch to OFF.
Equipped with remote or wall control: Press OFF button.
Equipped with thermostat: Set temperature to lowest setting.
2. Service technician should turn off electric power to the control when performing service.

593-913G

Final inspection by _____



C. After Appliance is Lit

Initial Break-in Procedure

When you light the appliance, you may notice that it produces heat which does have an associated odor or smell. If you feel this odor is excessive it may require the initial three to four hour continuous burn on high followed by a second burn up to 12 hours to fully drive off any odor from paint and lubricants used in the manufacturing process. Condensation of the glass is normal.



Note: The appliance should be run three to four hours on the initial start-up. Turn it off and let it cool completely. Remove and clean the glass. Replace the glass and run the appliance for an additional 12 hours. This will help to cure the products used in the paint and logs.

During this break-in period it is recommended that some windows in the house be opened for air circulation. This will help avoid setting off smoke detectors, and help eliminate any odors associated with the appliance's initial burning.

 WARNING	
	<p>Fire Risk. High Temperatures. Keep combustible household items away from appliance. Do NOT obstruct combustion and ventilation air.</p> <ul style="list-style-type: none"> Do NOT place combustible items on top of or in front of appliance. Keep furniture, draperies away from appliance.

CAUTION
<ul style="list-style-type: none"> Prevent accidental appliance operation when not attended. Unplug or remove batteries from remote control if absent or if appliance will not be used for an extended period of time. Property damage possible from elevated temperatures.

CAUTION
<p>Smoke and odors released during initial operation.</p> <ul style="list-style-type: none"> Open windows for air circulation. Leave room during initial operation. Smoke may set off smoke detectors. <p>Smoke and odors may be irritating to sensitive individuals.</p>

 WARNING	
	<p>Fire Hazard. Keep combustible materials, gasoline and other flammable vapors and liquids clear of appliance.</p> <ul style="list-style-type: none"> Do NOT store flammable materials in the appliance's vicinity. Do NOT use gasoline, lantern fuel, kerosene, charcoal lighter fluid or similar liquids in this appliance. Combustible materials may ignite.

D. Frequently Asked Questions

ISSUE	SOLUTIONS
Condensation on the glass	This is a result of gas combustion and temperature variations. As the appliance warms, this condensation will disappear.
Blue flames	This is a result of normal operation and the flames will begin to yellow as the appliance is allowed to burn for 20 to 40 minutes.
Odor from appliance	When first operated, this appliance may release an odor for the first several hours. This is caused by the curing of the paint and the burning off of any oils remaining from manufacturing. Odor may also be released from finishing materials and adhesives used around the appliance.
Film on the glass	This is a normal result of the curing process of the paint and logs. Glass should be cleaned within 3 to 4 hours of initial burning to remove deposits left by oils from the manufacturing process. A non-abrasive cleaner such as gas fireplace glass cleaner may be necessary. See your dealer.
Metallic noise	Noise is caused by metal expanding and contracting as it heats up and cools down, similar to the sound produced by a furnace or heating duct. This noise does not affect the operation or longevity of the appliance.
Is it normal to see the pilot flame burn continually?	In an intermittent pilot ignition system (IPI), the pilot flame should turn off when appliance is turned off. Some optional control systems available with IPI models may allow pilot flame to remain lit.

14 Troubleshooting

With proper installation, operation, and maintenance your gas appliance will provide years of trouble-free service. If you do experience a problem, this troubleshooting guide will assist a qualified service person in the diagnosis of a problem and the corrective action to be taken. This troubleshooting guide can only be used by a qualified service technician.

A. Intellifire Ignition System

Symptom	Possible Cause	Corrective Action
1. The ignitor/module makes noise, but no spark.	a. Incorrect wiring.	Verify "S" wire (white) for sensor and "I" wire (orange) for ignitor are connected to correct terminals on module and pilot assembly. Reversed wires at the module may cause system to make sparking noise, but spark may not be present at pilot hood.
	b. Loose connections or electrical shorts in the wiring.	Verify no loose connections or electrical shorts in wiring from module to pilot assembly. Rod closest to pilot hood should be ignitor. Verify connections underneath pilot assembly are tight; also verify connections are not grounding out to metal chassis, pilot burner, pilot enclosure, mesh screen if present, or any other metal object.
	c. Ignitor gap is too large.	Verify gap of igniter to pilot hood. The gap should be approximately .17 inch or 1/8 inch.
	d. Faulty module.	Turn ON/OFF rocker switch or wall switch to OFF position. Remove ignitor wire "I" from module. Place ON/OFF Rocker switch or wall switch in ON position. Hold ground wire about 3/16 inch away from "I" terminal on module. If there is no spark at "I" terminal module must be replaced. If there is a spark at "I" terminal, module is fine. Inspect pilot assembly for shorted sparker wire or cracked insulator around electrode.
2. Pilot won't light, there is no noise or spark.	a. Transformer installed correctly.	Verify that transformer is installed and plugged into module. Check voltage of transformer under load at spade connection on module with ON/OFF switch in ON position. Acceptable readings of a good transformer are between 3.2 and 2.8 volts AC.
	b. A shorted or loose connection in wiring configuration or wiring harness.	Remove and reinstall the wiring harness that plugs into module. Verify there is a tight fit. Verify pilot assembly wiring to module. Remove and verify continuity of each wire in wiring harness.
	c. Improper wall switch wiring.	Verify that 110/VAC power is "ON" to junction box.
	d. Module not grounded.	Verify black ground wire from module wire harness is grounded to metal chassis of appliance.
	e. Faulty module.	Turn ON/OFF rocker switch or wall switch to OFF position. Remove ignitor wire "I" from module. Place ON/OFF Rocker switch or wall switch in ON position. Hold ground wire about 3/16 inch away from "I" terminal on module. If there is no spark at "I" terminal module must be replaced. If there is a spark at "I" terminal, module is fine. Inspect pilot assembly for shorted sparker wire or cracked insulator around electrode.
3. Pilot lights but continues to spark, and main burner will not ignite. (If the pilot continues to spark after the pilot flame has been lit, flame rectification has not occurred.)	a. A shorted or loose connection in sensor rod.	Verify all connections to wiring diagram in manual. Verify connections underneath pilot assembly are tight. Verify connections are not grounding out to metal chassis, pilot burner, pilot enclosure or screen if present, or any other metal object.
	b. Poor flame rectification or contaminated sensor rod.	Verify that flame is engulfing sensor rod. If the pilot assembly does not have a ground strap, consider installing one to increase flame rectification. Verify correct pilot orifice is installed and inlet gas specifications. Flame carries rectification current, not the gas. If flame lifts from pilot hood, the circuit is broken. A wrong orifice or too high an inlet pressure can cause pilot flame to lift. The sensor rod may be contaminated. Clean sensor rod with emery cloth.

Intellifire Ignition System - (continued)

Symptom	Possible Cause	Corrective Action
3. (Continued) Pilot lights but continues to spark, and main burner will not ignite. (If the pilot continues to spark after the pilot flame has been lit, flame rectification has not occurred.)	c. Module is not grounded.	Verify that module is securely grounded to metal chassis of appliance. Verify that wire harness is firmly connected to module.
	d. Damaged pilot assembly or dirty sensor rod.	Verify that ceramic insulator around the sensor rod is not cracked, damaged, or loose. Verify connection from sensor rod to white sensor wire. Clean sensor rod with emery cloth to remove any contaminants that may have accumulated on sensor rod. Verify continuity with a multimeter with ohms set at lowest range.
	e. Faulty module.	Turn ON/OFF rocker switch or wall switch to OFF position. Remove ignitor wire "I" from module. Place ON/OFF Rocker switch or wall switch in ON position. Hold ground wire about 3/16 inch away from "I" terminal on module. If there is no spark at "I" terminal module must be replaced. If there is a spark at "I" terminal, module is fine. Inspect pilot assembly for shorted sparker wire or cracked insulator around electrode.
4. Pilot sparks, but Pilot will not light.	a. Correct gas supply.	Verify that incoming gas line ball valve is "open". Verify that inlet pressure reading is within acceptable limits, inlet pressure must not exceed 14 in. W.C.
	b. Ignitor gap is too large.	Verify that spark gap from ignitor to pilot hood is .17 in. or 1/8 in.
	c. Module is not grounded.	Verify module is securely grounded to metal chassis of appliance.

15 Maintaining and Servicing Appliance

Although the frequency of appliance servicing and maintenance will depend on use and the type of installation, a qualified service technician should perform an appliance checkup at the beginning of each heating season.

⚠ WARNING

Risk of injury or property damage.

Before servicing:

- Turn off gas.
- Turn off electricity to appliance.
- Disable remote control, if one is present.
- Ensure appliance is completely cooled.

After servicing:

- Replace any screen or barrier that was removed.
- Reseal and reinstall any venting removed for servicing.

⚠ WARNING

Annual inspection by qualified technician recommended.

Check:

- Condition of doors, surrounds and fronts.
- Condition of glass, glass assembly and glass seal.
- Obstructions of combustion and ventilation air.
- Condition of logs.
- Condition of firebox.
- Burner ignition and operation.
- Burner air shutter adjustment
- Gas connections and fittings.
- Obstructions of termination cap.

Clean:

- Glass
- Air passageways, grilles, control compartment
- Burner, burner ports

Risk of:

- Fire
- Delayed ignition or explosion
- Exposure to combustion fumes
- Odors



CAUTION

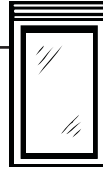

Handle glass assembly with care.

Note: Clean glass after initial 3-4 hours operation. **Longer operation without cleaning glass may cause a permanent white film on glass.**

When cleaning glass door:

- Avoid striking, scratching or slamming glass.
- Do NOT use abrasive cleaners.
- Use a hard water deposit glass cleaner on white film.
- Do NOT clean glass when hot.
- Turn off appliance after 3-4 hours of operation and **ALLOW TO COOL.**
- Remove and clean glass assembly.
- Replace glass assembly and operate appliance for additional 12 hours.

Refer to maintenance instructions.

⚠ WARNING



Inspect external vent cap regularly.

- Ensure no debris blocks cap.
- Combustible materials blocking cap may ignite.
- Restricted air flow affects burner operation.



A. Maintenance Tasks

Inspect	Maintenance Tasks
Doors, Surrounds and Fronts	1. Assess condition of screen and replace as necessary. Recommend addition of screen if one is not present.
	2. Inspect for scratches, dents or other damage and repair as necessary.
	3. Verify no obstructions to airflow through the louvers.
	4. Verify maintenance of proper clearance to combustible household objects.
Gasket Seal, Glass Assembly and Glass	1. Inspect gasket seal and its condition.
	2. Inspect glass panels for scratches and nicks that can lead to breakage when exposed to heat.
	3. Confirm there is no damage to glass or glass frame. Replace as necessary.
	4. Verify that latches engage properly, clip studs are not stripped, and glass attachment components are intact and operating properly. Replace as necessary.
	5. Clean glass. Replace glass assembly if severely coated with silicate deposits that cannot be removed.
Logs	1. Inspect for broken, damaged, or missing logs. Replace as necessary.
	2. Verify correct log placement and no flame impingement causing sooting. Correct as necessary.
Firebox	1. Replace appliance if firebox has any large cracks that penetrate through firebox.
Burner Ignition and Operation	1. Verify burner is properly secured and aligned with pilot or igniter.
	2. Clean off burner top, inspect for plugged ports, corrosion or deterioration. Replace burner if necessary.
	3. Replace ember materials with new dime-size and shape pieces. Do not block ports or obstruct lighting paths.
	4. Check for smooth lighting and ignition carryover to all ports. Verify there is no ignition delay.
	5. Inspect for lifting or other flame problems.
	6. Verify air shutter is clear of dust and debris.
	7. Inspect orifice for soot, dirt or corrosion.
	8. Verify manifold and inlet pressures. Adjust regulator as required.
	9. Inspect pilot flame strength. Clean or replace orifice as necessary.
	10. Inspect IPI sensor rod for soot, corrosion and deterioration. Clean with emery cloth or replace as required.
Venting / Outside Air kit	1. Inspect venting for blockage or obstruction such as bird nests, leaves, etc.
	2. Confirm that termination cap remains clear and unobstructed by plants, etc.
	3. Verify that termination cap clearance to subsequent construction (building additions, decks, fences or sheds) has been maintained.
	4. Inspect for corrosion or separation.
	5. Verify weather stripping, sealing and flashing remains intact.
Remote controls	1. Verify operation of remote.
	2. Replace batteries in remote transmitters.

16 Reference Materials

A. Appliance Dimension Diagram

Dimensions are actual appliance dimensions. Use for reference only. For framing dimensions and clearances refer to Section 3.

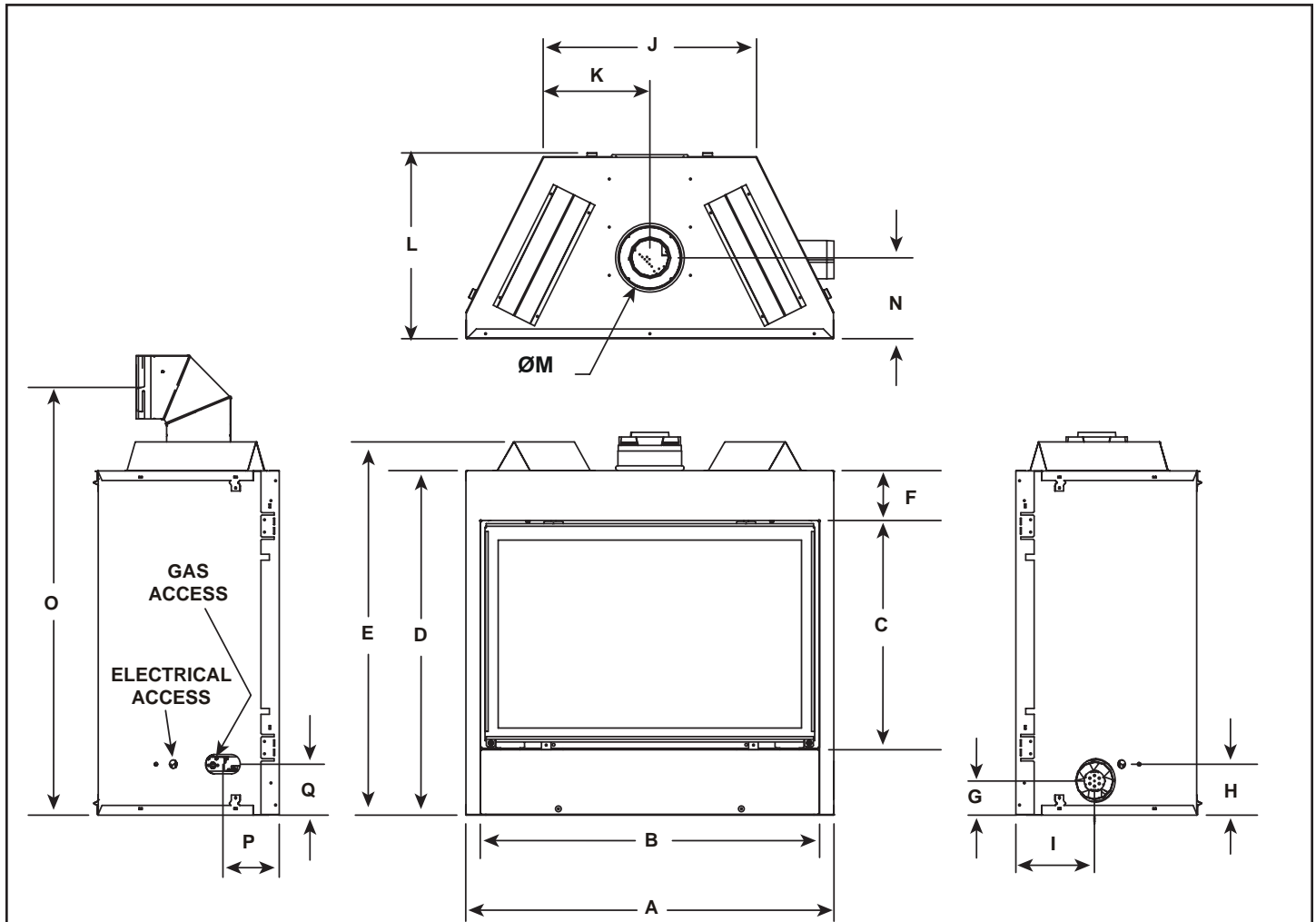

Location	Inches	Millimeters
A	38-1/4	971
B	35-1/4	895
C	23-13/16	605
D	35-3/4	908
E	39-1/2	1003
F	5-3/16	132
G	3-9/16	90
H	5/16	135
I	8-3/16	208

Location	Inches	Millimeters
J	22-3/16	564
K	11-1/8	283
L	19-1/2	495
M	6-5/8	168
N	8-7/16	214
O	44-3/8	1127
P	5-7/8	149
Q	5-1/4	134

Figure 16.1 Appliance Dimensions

B. Vent Components Diagrams

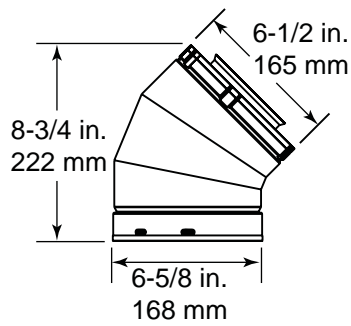

SLP45
45° Elbow

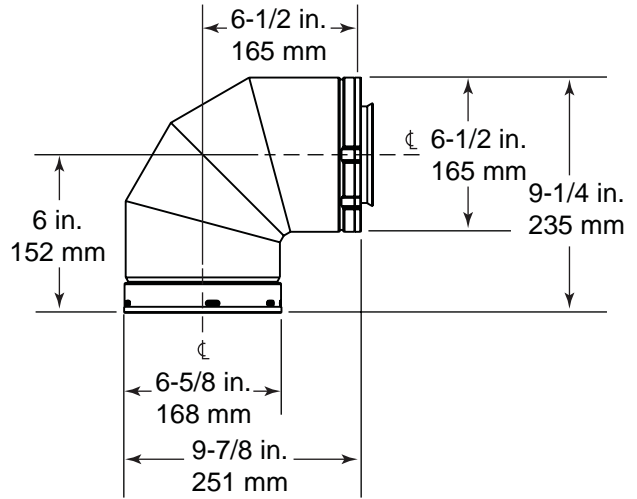

SLP90
90° Elbow

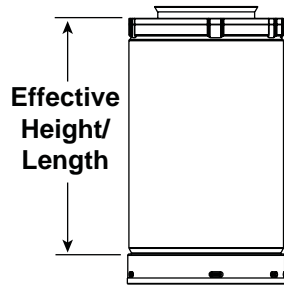

SLP-PIPE

Effective Height/Length

Pipe	inches	mm
SLP4	4	102
SLP6	6	152
SLP12	12	305
SLP24	24	610
SLP36	36	914
SLP48	48	1219
SLP6A	2 - 6	51 - 152
SLP12A	2 - 12	51 - 305
SLP-FLEX-2	24	610
SLP-FLEX-3	36	914
SLP-FLEX-5	60	1524
SLP-FLEX-10	120	3048

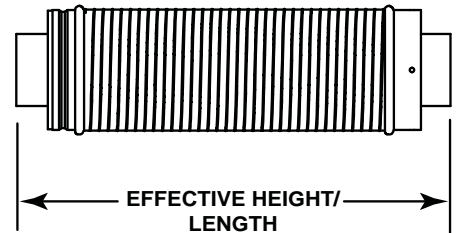

SLP-FLEX-PIPE

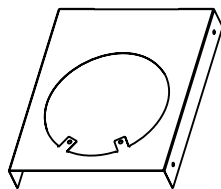

SLP-HVS
Horizontal Pipe
Support

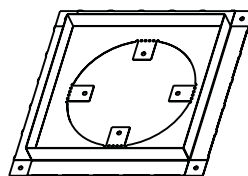

SLP-FS
Ceiling Firestop

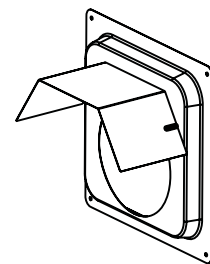

SLP-WS
Wall Shield Firestop

Figure 16.2 SLP Series Vent Components

B. Vent Components Diagrams (continued)

Note: Heat shields MUST overlap by a minimum of 1-1/2 in. (38 mm). The heat shield is designed to be used on a wall 4 in. to 7-1/4 in. (102 mm to 184 mm) thick. If wall thickness is less than 4 in. (102 mm) the existing heat shields must be field trimmed. If wall thickness is greater than 7-1/4 in. (184 mm) a DVP-HSM-B will be required.

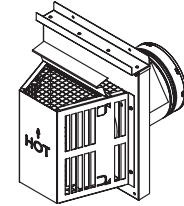
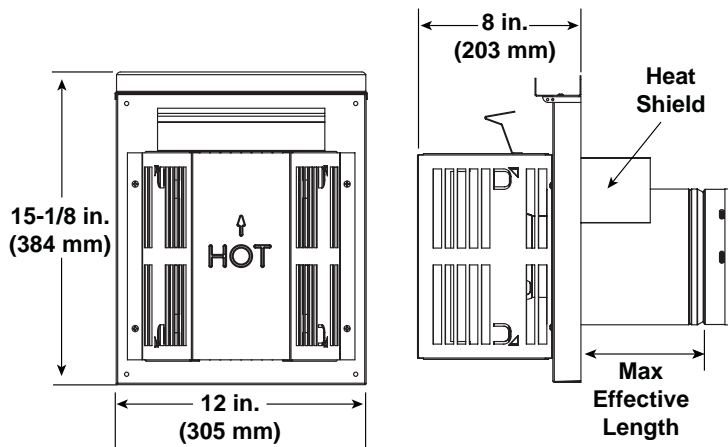

Term Cap	Minimum Effective Length	Maximum Effective Length
Trap1	3-1/8 in.	4-3/4 in.
	79 mm	121 mm
Trap2	5-1/4 in.	9-1/4 in.
	133 mm	235 mm

SLP-TRAP
Horizontal Termination Cap

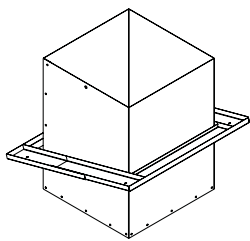

SLP-CCS-BK
Cathedral Ceiling
Support Box-Black

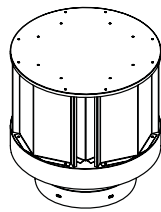

SLP-TVHW
Vertical
Termination Cap

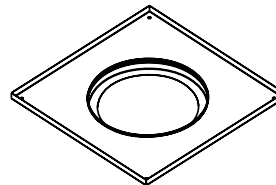

SLP-DCF-BK
Ceiling Firestop
Black

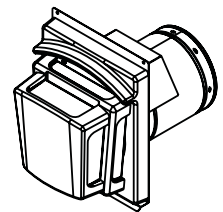

DVP-FBHT
Horizontal
Termination Cap

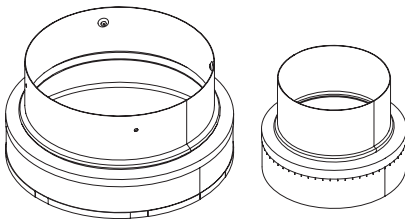

SL-2DVP
Adapter

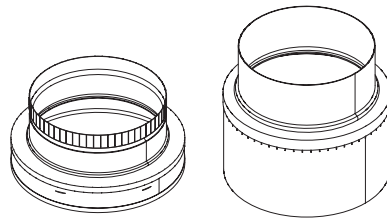

DVP-2SL
Adapter

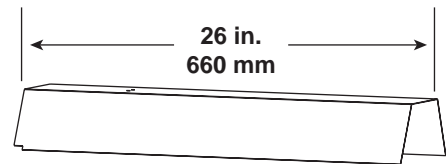

DVP-HSM-B
Extended Heat Shield

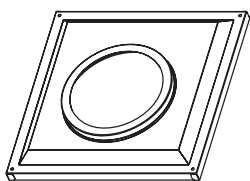

SLP-WT-BK
Wall Thimble-Black

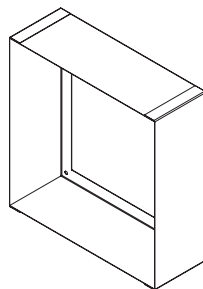

VPK-INFINITY
Vinyl Siding Protect Kit

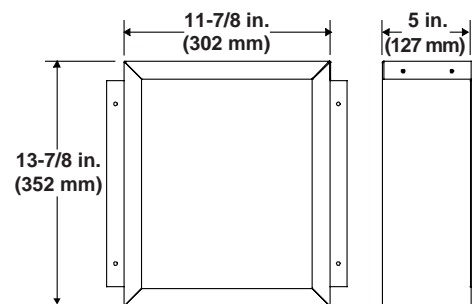

DVP-BEK2
DVP-HPC Cap Brick Extension

Figure 16.3 SLP Series Vent Components

D. Limited Lifetime Warranty

Hearth & Home Technologies Inc. LIMITED LIFETIME WARRANTY

Hearth & Home Technologies Inc., on behalf of its hearth brands ("HHT"), extends the following warranty for HHT gas, wood, pellet, coal and electric hearth appliances that are purchased from an HHT authorized dealer.

WARRANTY COVERAGE:

HHT warrants to the original owner of the HHT appliance at the site of installation, and to any transferee taking ownership of the appliance at the site of installation within two years following the date of original purchase, that the HHT appliance will be free from defects in materials and workmanship at the time of manufacture. After installation, if covered components manufactured by HHT are found to be defective in materials or workmanship during the applicable warranty period, HHT will, at its option, repair or replace the covered components. HHT, at its own discretion, may fully discharge all of its obligations under such warranties by replacing the product itself or refunding the verified purchase price of the product itself. The maximum amount recoverable under this warranty is limited to the purchase price of the product. This warranty is subject to conditions, exclusions and limitations as described below.

WARRANTY PERIOD:

Warranty coverage begins on the date of installation. In the case of new home construction, warranty coverage begins on the date of first occupancy of the dwelling or six months after the sale of the product by an independent, authorized HHT dealer/ distributor, whichever occurs earlier. The warranty shall commence no later than 24 months following the date of product shipment from HHT, regardless of the installation or occupancy date. The warranty period for parts and labor for covered components is produced in the following table.

The term "Limited Lifetime" in the table below is defined as: 20 years from the beginning date of warranty coverage for gas appliances, and 10 years from the beginning date of warranty coverage for wood, pellet, and coal appliances. These time periods reflect the minimum expected useful lives of the designated components under normal operating conditions.

Warranty Period		HHT Manufactured Appliances and Venting							Components Covered
Parts	Labor	Gas	Wood	Pellet	EPA Wood	Coal	Electric	Venting	
1 Year		X	X	X	X	X	X	X	All parts and material except as covered by Conditions, Exclusions, and Limitations listed
2 years				X	X	X			Igniters, electronic components, and glass
		X	X	X	X	X			Factory-installed blowers
			X						Molded refractory panels
3 years				X					Firepots and burnpots
5 years	1 year			X	X				Castings and baffles
7 years	3 years		X	X	X				Manifold tubes, HHT chimney and termination
10 years	1 year	X							Burners, logs and refractory
Limited Lifetime	3 years	X	X	X	X	X			Firebox and heat exchanger
90 Days		X	X	X	X	X	X	X	All replacement parts beyond warranty period

See conditions, exclusions, and limitations on next page.

D. Limited Lifetime Warranty (*continued*)

WARRANTY CONDITIONS:

- This warranty only covers HHT appliances that are purchased through an HHT authorized dealer or distributor. A list of HHT authorized dealers is available on the HHT branded websites.
- This warranty is only valid while the HHT appliance remains at the site of original installation.
- Contact your installing dealer for warranty service. If the installing dealer is unable to provide necessary parts, contact the nearest HHT authorized dealer or supplier. Additional service fees may apply if you are seeking warranty service from a dealer other than the dealer from whom you originally purchased the product.
- Check with your dealer in advance for any costs to you when arranging a warranty call. Travel and shipping charges for parts are not covered by this warranty.

WARRANTY EXCLUSIONS:

This warranty does not cover the following:

- Changes in surface finishes as a result of normal use. As a heating appliance, some changes in color of interior and exterior surface finishes may occur. This is not a flaw and is not covered under warranty.
- Damage to printed, plated, or enameled surfaces caused by fingerprints, accidents, misuse, scratches, melted items, or other external sources and residues left on the plated surfaces from the use of abrasive cleaners or polishes.
- Repair or replacement of parts that are subject to normal wear and tear during the warranty period. These parts include: paint, wood, pellet and coal gaskets; firebricks; grates; flame guides; and the discoloration of glass.
- Minor expansion, contraction, or movement of certain parts causing noise. These conditions are normal and complaints related to this noise are not covered by this warranty.
- Damages resulting from: (1) failure to install, operate, or maintain the appliance in accordance with the installation instructions, operating instructions, and listing agent identification label furnished with the appliance; (2) failure to install the appliance in accordance with local building codes; (3) shipping or improper handling; (4) improper operation, abuse, misuse, continued operation with damaged, corroded or failed components, accident, or improperly/incorrectly performed repairs; (5) environmental conditions, inadequate ventilation, negative pressure, or drafting caused by tightly sealed constructions, insufficient make-up air supply, or handling devices such as exhaust fans or forced air furnaces or other such causes; (6) use of fuels other than those specified in the operating instructions; (7) installation or use of components not supplied with the appliance or any other components not expressly authorized and approved by HHT; (8) modification of the appliance not expressly authorized and approved by HHT in writing; and/or (9) interruptions or fluctuations of electrical power supply to the appliance.
- Non-HHT venting components, hearth components or other accessories used in conjunction with the appliance.
- Any part of a pre-existing fireplace system in which an insert or a decorative gas appliance is installed.
- HHT's obligation under this warranty does not extend to the appliance's capability to heat the desired space. Information is provided to assist the consumer and the dealer in selecting the proper appliance for the application. Consideration must be given to appliance location and configuration, environmental conditions, insulation and air tightness of the structure.

This warranty is void if:

- The appliance has been over-fired or operated in atmospheres contaminated by chlorine, fluorine, or other damaging chemicals. Over-firing can be identified by, but not limited to, warped plates or tubes, rust colored cast iron, bubbling, cracking and discoloration of steel or enamel finishes.
- The appliance is subjected to prolonged periods of dampness or condensation.
- There is any damage to the appliance or other components due to water or weather damage which is the result of, but not limited to, improper chimney or venting installation.

LIMITATIONS OF LIABILITY:

- The owner's exclusive remedy and HHT's sole obligation under this warranty, under any other warranty, express or implied, or in contract, tort or otherwise, shall be limited to replacement, repair, or refund, as specified above. In no event will HHT be liable for any incidental or consequential damages caused by defects in the appliance. Some states do not allow exclusions or limitation of incidental or consequential damages, so these limitations may not apply to you. This warranty gives you specific rights; you may also have other rights, which vary from state to state. **EXCEPT TO THE EXTENT PROVIDED BY LAW, HHT MAKES NO EXPRESS WARRANTIES OTHER THAN THE WARRANTY SPECIFIED HEREIN. THE DURATION OF ANY IMPLIED WARRANTY IS LIMITED TO DURATION OF THE EXPRESSED WARRANTY SPECIFIED ABOVE.**

E. Contact Information



No one builds a better fire

Heat & Glo, a brand of Hearth & Home Technologies Inc.
7571 215th Street West, Lakeville, MN 55044
www.heatnglo.com

Please contact your Heat & Glo dealer with any questions or concerns.
For the location of your nearest Heat & Glo dealer,
please visit www.heatnglo.com.

- NOTES -

CAUTION



DO NOT DISCARD THIS MANUAL

- Important operating and maintenance instructions included.
- Read, understand and follow these instructions for safe installation and operation.
- Leave this manual with party responsible for use and operation.



This product may be covered by one or more of the following patents: (United States) 4593510, 4686807, 4766876, 4793322, 4811534, 5000162, 5016609, 5076254, 5113843, 5191877, 5218953, 5263471, 5328356, 5341794, 5347983, 5429495, 5452708, 5542407, 5601073, 5613487, 5647340, 5688568, 5762062, 5775408, 5890485, 5931661, 5941237, 5947112, 5996575, 6006743, 6019099, 6048195, 6053165, 6145502, 6170481, 6237588, 6296474, 6374822, 6413079, 6439226, 6484712, 6543698, 6550687, 6601579, 6672860, 6688302B2, 6715724B2, 6729551, 6736133, 6748940, 6748942, 6769426, 6774802, 6796302, 6840261, 6848441, 6863064, 6866205, 6869278, 6875012, 6880275, 6908039, 6919884, D320652, D445174, D462436; (Canada) 1297749, 2195264, 2225408, 2313972; (Australia) 780250, 780403, 1418504 or other U.S. and foreign patents pending.

Printed in U.S.A. - Copyright 2010