

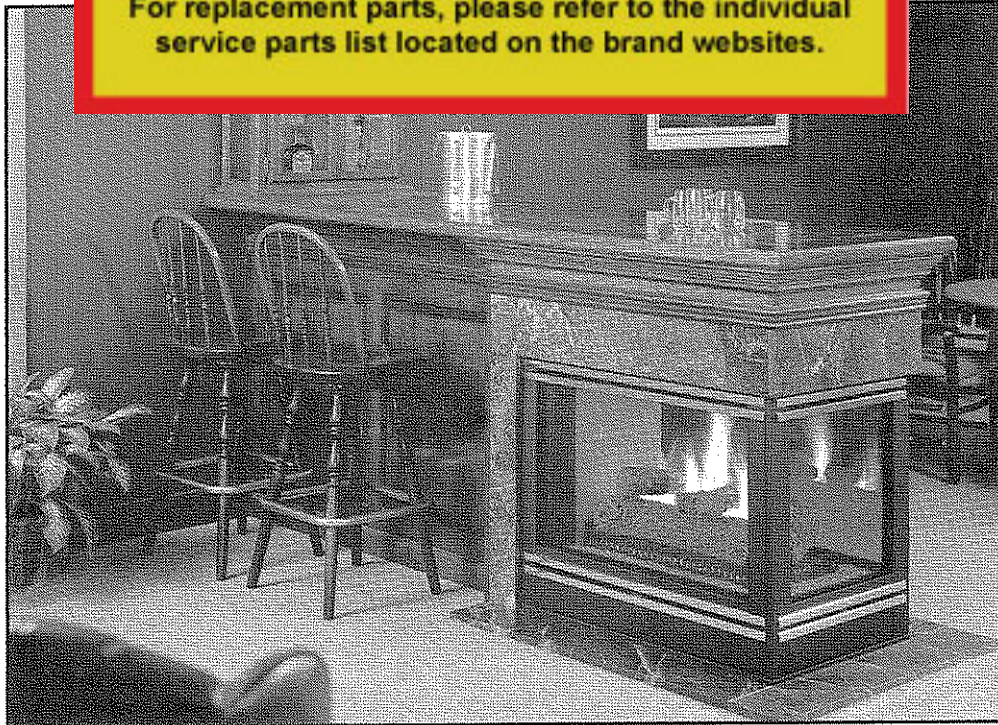

This appliance has been retired.  
Service parts pages within have been removed.  
For replacement parts, please refer to the individual  
service parts list located on the brand websites.



U.S. PATENTS 4,875,464; 5,000,162; and 5,016,609

**MODEL PIER-DVT  
MODEL PIER-GDV  
MODEL ST-DVT  
INSTALLATION AND OPERATION  
INSTRUCTIONS**



**A.G.A. Design Certified  
and  
CGA Certified**



**THIS MANUAL MUST BE USED FOR INSTALLATION AND RETAINED BY HOMEOWNER FOR  
OPERATION AND MAINTENANCE.**

**HEAT-N-GLO FIREPLACE PRODUCTS, INC.  
6665 W. Hwy 13 Savage, MN 55378 (612)890-8367**



## INSTALLATION AND OPERATION INSTRUCTIONS

PLEASE READ THIS MANUAL BEFORE INSTALLING AND USING THE FIREPLACE

MODELS ST-DVT, PIER-GDV and PIER-DVT ARE A.G.A. DESIGN CERTIFIED AND CGA CERTIFIED FOR NATURAL GAS OR PROPANE

Requires one of the following kits systems for installation:

DVK-01D,	DVK-02D	HORIZONTAL TERMINATION KITS
DVK-01SD,	DVK-02SD	
DVK-01TRD,	DVK-02TRD	
DVK-TVCD		VERTICAL TERMINATION KITS

### FOR YOUR SAFETY

#### What to do if you smell gas:

- Extinguish any open flame.
- Do not try to light any appliance.
- Do not touch any electrical switch; do not use any phone your building.
- Immediately call your gas supplier from a neighbor's phone. Follow the gas supplier's instructions.
- If you cannot reach your gas supplier, call the fire department.

### FOR YOUR SAFETY

Do not store or use gasoline or other flammable vapors and liquids in the vicinity of this or any other appliance.

**WARNING: IMPROPER INSTALLATION, ADJUSTMENT, ALTERATION, SERVICE OR MAINTENANCE CAN CAUSE INJURY OR PROPERTY DAMAGE. REFER TO MANUAL. FOR ASSISTANCE OR ADDITIONAL INFORMATION CONSULT A QUALIFIED INSTALLER, SERVICE AGENCY OR THE GAS SUPPLIER.**

**IMPORTANT:** Read all instructions carefully before starting installation. Failure to follow these installation instructions may result in a possible fire hazard and will void the warranty.

Save this Manual for future reference.

Copyright 1995, Heat-N-Glo Fireplace Products, Inc., 6665 W. Hwy 13, Savage, MN 55378  
Printed in U.S.A.

## TABLE OF CONTENTS

1.0	Introduction .....	4
2.0	Installation Precautions .....	4
3.0	Installation Instructions .....	6
3.1	Vent System Approvals .....	8
3.2	Vent System Installation Precautions .....	13
3.2.1	Installing the Vent System in a Chase .....	13
3.3	Installing Vent System Components .....	13
3.3.1	Installing Support Brackets .....	14
3.3.2	Installing Firestops .....	14
3.4	Horizontal Terminations .....	15
3.5	Vertical Terminations .....	16
3.5.1	Penetrating the Roof .....	16
3.5.2	Minimum Vent Height Above the Roof .....	18
3.6	Permanently Anchoring the Fireplace .....	18
3.7	Connecting the Gas Line .....	19
3.8	Electrical Wiring for Optional Kits .....	19
3.8.1	Installing Electrical Service to the Junction Box .....	20
3.9	Wall Switch Wiring .....	21
3.10	Finishing .....	21
3.11	Hearth Extension .....	21
4.0	Electrical Safety System .....	22
5.0	Operating Guidelines and Maintenance Instructions .....	23
5.1	Glass Door Removal .....	23
5.2	Cleaning Burner and Pilot .....	24
5.3	Log Replacement .....	24
5.4	Glass Door Replacement .....	24
6.0	Safety Information .....	25
7.0	Lighting Instructions .....	26
LPG (Propane) Information .....	27	
8.0	High Altitude Installation .....	27
9.0	Trouble Shooting .....	28-31
10.0	Replacement Parts .....	32-35
11.0	Direct Spark Ignition (DSI): Models ST-DVT-DSI, PIER-GDV-DSI, and PIER-DVT-DSI .....	36-38
	WARRANTY INFORMATION .....	39

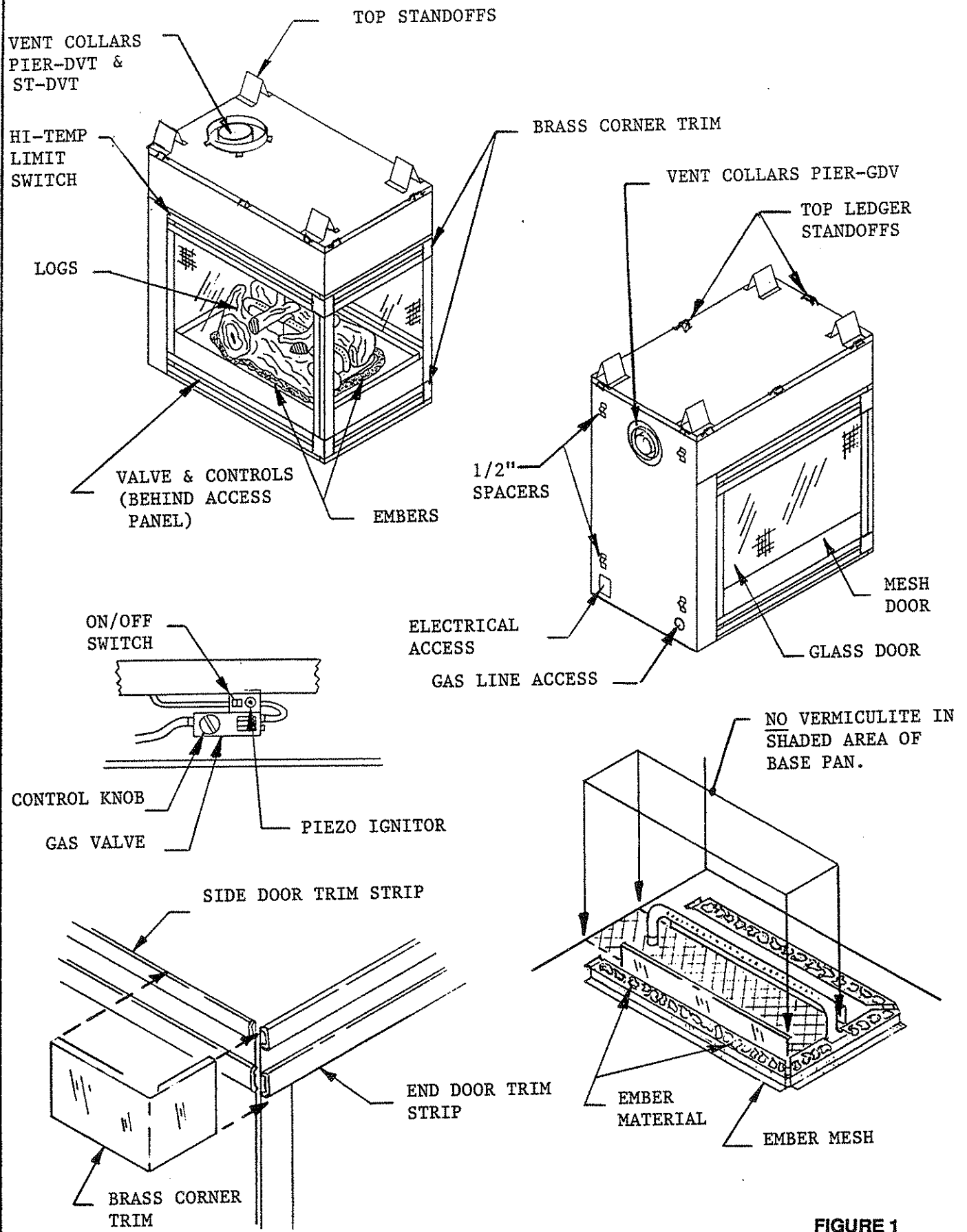

FIGURE 1

## 1.0 INTRODUCTION

The information in this manual pertains to Models ST-DVT, PIER-GDV, and PIER-DVT unless specifically noted.

These models are Direct Vent Decorative Gas Appliances. It is designed to operate with all combustion air being siphoned from the outside of the building and all exhaust gases expelled to the outside of the building.

### **WARNING: THIS UNIT IS NOT FOR USE WITH SOLID FUEL.**

This model **MUST** use one or more of the vent kits listed on page 1 and described in the venting section of this manual. **NO** other vent systems may be used.

The control system for this model is a millivolt type. It consists of a gas control valve/regulator, a standing pilot assembly, a thermopile, a piezo ignitor, an ON/OFF rocker switch, and a safety high temperature limit switch. An ON/OFF Wall Switch (WSK-21) and instructions for wiring it to the control system are also included with the unit. The controls are located in the lower compartment behind the trim door of the fireplace. Access to this compartment is gained by rotating up the bottom panel of the trim door. See Figure 1.

### **WARNING: DO NOT CONNECT 110-120 VAC TO THE GAS CONTROL VALVE OR CONTROL WIRING SYSTEM OF THIS UNIT.**

Installation must conform to local codes. In the absence of local codes installation must conform with the current National Fuel Gas Code ANSI Z223.1 (in the United States) or with the current installation code CAN/CGA - B149 (in Canada).

The appliance when installed must be electrically grounded in accordance with local codes; in absence of local codes, with the current National Electric Code ANSI/NFPA NO. 70 (in the United States) or with the current CSA C22.1 Canadian Electric Code (in Canada).

**NOTE: INSTALLATION AND REPAIR SHOULD BE DONE BY A QUALIFIED SERVICE PERSON. THE APPLIANCE SHOULD BE INSPECTED BEFORE USE AND AT LEAST ANNUALLY BY A PROFESSIONAL SERVICE PERSON. MORE FREQUENT CLEANING MAY BE REQUIRED DUE TO EXCESSIVE LINT FROM CARPETING, BEDDING MATERIAL, ETC. IT IS IMPERATIVE THAT THE UNIT'S CONTROL COMPARTMENT, BURNERS, AND CIRCULATING AIR PASSAGEWAYS BE KEPT CLEAN TO PROVIDE FOR ADEQUATE COMBUSTION AND VENTILATION AIR.**

Provide adequate clearances around air openings into the combustion chamber and allow accessibility clearance for servicing and proper operation. **NEVER OBSTRUCT THE FRONT OPENINGS OF THE FIREPLACE OR THE DIRECT VENT CAP ON THE EXTERIOR OF THE HOUSE.**

Minimum clearances in inches to combustibles are: Glass Sides 36, Floor 0, Back 1/2, Top 4 1/2 (top and back clearances are defined by the standoffs). Minimum distance from the ceiling to the top front of the unit is 31 inches. The back of the unit may **NOT** be recessed within combustible construction.

Minimum inlet gas supply pressure for purpose of input adjustment is 5.0 inches water column natural gas and 11 inches water column propane. Maximum inlet gas supply pressure is 10.5 inches w.c. natural gas and 13.0 inches w.c. propane. For the purpose of input adjustment, inlet gas supply pressure should be 7.0 inches w.c. natural gas and 11.0 inches w.c. propane and manifold pressure should be set at 3.5 inches w.c. and 10.0 inches w.c. respectively.

A 1/8-inch N.P.T. plugged tapping is provided on the outlet side of the gas control for a test gauge connection to measure the manifold pressure. Provisions must be made to attach a test gauge to a 1/8-inch NPT plugged tapping immediately upstream of the gas supply connection to the appliance to measure inlet pressure.

The appliance and its individual shut off valve must be disconnected from the gas supply piping system during any pressure testing of the system at test pressures in excess of 1/2 psig (3.45 kPa).

This appliance must be isolated from the gas supply piping system by closing its individual manual shut-off valve during any pressure testing of the gas supply piping system at test pressures equal to or less than 1/2 psig (3.45 kPa).

## 2.0 INSTALLATION PRECAUTIONS

This direct vent gas fireplace and its components are tested and safe when installed in accordance with this Installation Manual. Report to your dealer any parts damaged in shipment, specifically check glass condition. The vent system and gas logs are in separate packages. Read all instructions before starting installation and follow these instructions carefully during installation to insure maximum benefit and safety. Failure to follow them will void your warranty and may present a fire hazard.



The Heat-N-Glo Fireplace Products, Inc. warranty will be voided by, and Heat-N-Glo Fireplace Products, Inc. disclaims any responsibility for, the following actions:

- Installation of any damaged fireplace or chimney component
- Modification of the fireplace or direct vent system
- Installation other than as instructed by Heat-N-Glo Fireplace Products, Inc.
- Improper positioning of the gas logs or the glass door
- Installation and/or use of any component part not manufactured or approved by Heat-N-Glo Fireplace Products, Inc., not withstanding any independent testing laboratory or other party approval of such component part or accessory.

**ANY SUCH ACTION MAY POSSIBLY CAUSE A FIRE HAZARD.**

Consult your local building codes.

**NOTE:** The appliance has an airtight combustion chamber and takes 100% outside air for combustion. This appliance requires a direct vent kit (see venting section of this manual for details.) Both Natural Gas and Propane units may be installed in a bedroom.

**THIS FIREPLACE AND VENT ASSEMBLY MUST BE VENTED TO THE OUTDOORS AND MUST NEVER BE ATTACHED TO A CHIMNEY SERVING A SOLID FUEL BURNING APPLIANCE.**

**NOTE:** When installing the vent kits, it is imperative that the vent cap (horizontal termination) be NO more than a 1/4" below horizontal.

To install the logs, vermiculite, and burner ember material, remove the front (control side of the unit) mesh trim and glass door assemblies. Remove the top and bottom brass corners of the mesh door first, by sliding them out of the brass trim strips on the mesh doors (See Figure 1). Lift the mesh door off the retaining pins to remove it. See SECTION 5.1 for glass door removal.

Open the bag of vermiculite and spread it evenly on the bottom of the firebox making sure not to block the air hole at the base of the burner or the air hole in the center of the base pan beneath the burner (See Figure 1).

**NOTE:** It is essential for proper unit operation that the vermiculite contained in the plastic bag be spread evenly across the bottom of the firebox.

**CAUTION:** No vermiculite can be present in the center cut-out area between the lower burner tubes (See Figure 1).

Two separate bags of ember materials are shipped with this unit. The bag labeled Golden Ember (GE-93) is flame colorant material. The bag labeled Glowing Ember (050-721) is standard glowing ember material.

**INITIAL SET-UP:** Alternately place a single layer of dime size and shape pieces of Golden Ember (GE-93) and Glowing Ember (050-721) onto the top of the lower burner ember screen. See Figure 1.

Save the remaining ember materials for use during fireplace servicing.

**FIREPLACE SERVICING:** Frequency of fireplace servicing will depend upon use and type of installation.

Carefully brush away or vacuum up any loose materials on the lower burner ember screen. Alternately place dime size and shape pieces of Golden Ember (GE-93) flame colorant replacement material and glowing Ember (050-721) standard ember material onto any open areas on top of the ember screen.

Save remaining ember materials and repeat this procedure at the next fireplace servicing.

**NOTE:** It may be necessary to clean the glass door after replenishing the flame colorant material. Film deposits on the inside of the glass door should be cleaned off using a household glass cleaner. **DO NOT** handle or attempt to clean the glass when it is **HOT**.

To install the logs, place the simulated bark cover pieces on top of the two burner deflectors. Place the bottom front and rear logs on the andiron which surrounds the burner (See Figure 2). Position the middle right and left logs in the cut-out areas on top of the bottom logs. Place the top left and right twigs on top of the middle logs. See Figure 2 for proper log positioning.

**WARNING: THE GAS LOGS MUST BE PROPERLY POSITIONED, WITH NO FLAME IMPINGEMENT ON THEM, OR THE FIREPLACE WILL NOT FUNCTION PROPERLY AND MAY RESULT IN SOOT ACCUMULATION ON THE INSIDE OF THE FIREBOX. IF THE BURNER FLAME IMPINGES ON THE LOGS, REPOSITION THEM SO THAT NO IMPINGEMENT OCCURS.**

Replace the glass door and trim assemblies. **THE UNIT WILL NOT OPERATE PROPERLY UNLESS THE GLASS DOORS ARE SECURED IN PLACE AND SEALED.**

**WARNING: DO NOT OPERATE APPLIANCE WITH THE GLASS DOORS REMOVED, CRACKED, OR BROKEN. REPLACEMENT OF THE GLASS DOORS SHOULD BE DONE BY A LICENSED OR QUALIFIED PERSON. DO NOT STRIKE OR SLAM GLASS DOORS.**

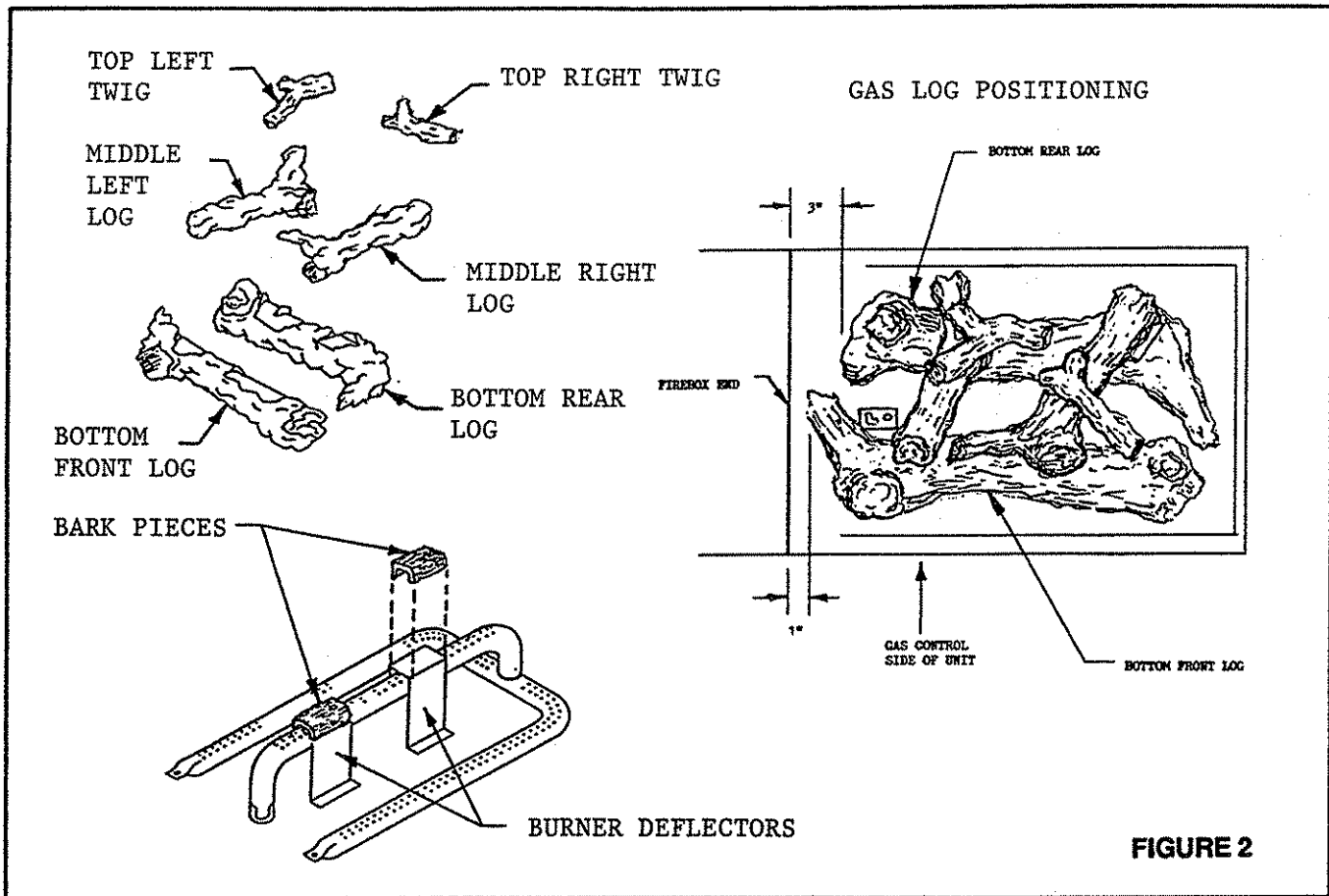

**FIGURE 2**

**WARNING: GLASS DOOR ASSEMBLIES SHALL ONLY BE REPLACED AS A COMPLETE UNIT AS SUPPLIED BY THE GAS FIREPLACE MANUFACTURER. NO SUBSTITUTE MATERIALS MAY BE USED.**

**WARNING: THE GLASS DOOR ASSEMBLIES MUST BE IN PLACE AND SEALED AND THE TRIM ASSEMBLIES MUST BE IN PLACE ON THE FIREPLACE BEFORE THE UNIT CAN BE PLACED INTO SAFE OPERATION.**

Prior to first firing, read Operation Instructions section of this manual.

Do not use this appliance if any part has been under water. Immediately call a qualified service technician to inspect the unit and to replace any part of the control system and any gas control which has been underwater.

DUE TO HIGH TEMPERATURE, THE APPLIANCE SHOULD BE LOCATED OUT OF TRAFFIC AREAS AND AWAY FROM FURNITURE AND DRAPERIES. CLOTHING OR FLAMMABLE MATERIAL SHOULD NOT BE PLACED ON OR NEAR THE APPLIANCE.

**NOTE: IF EXTERIOR WALLS ARE FINISHED WITH VINYL SIDING, IT IS NECESSARY TO INSTALL THE VINYL PROTECTOR KIT (VPK-DV) TO THE TOP OF THE EXTERIOR FIRESTOP.**

### 3.0 INSTALLATION INSTRUCTIONS

In planning the installation for the fireplace it is necessary to determine where the unit is to be installed, the type of vent system to be used (straight out or elevated), and whether optional accessories (fan or remote control) are desired. Gas supply piping should also be planned.

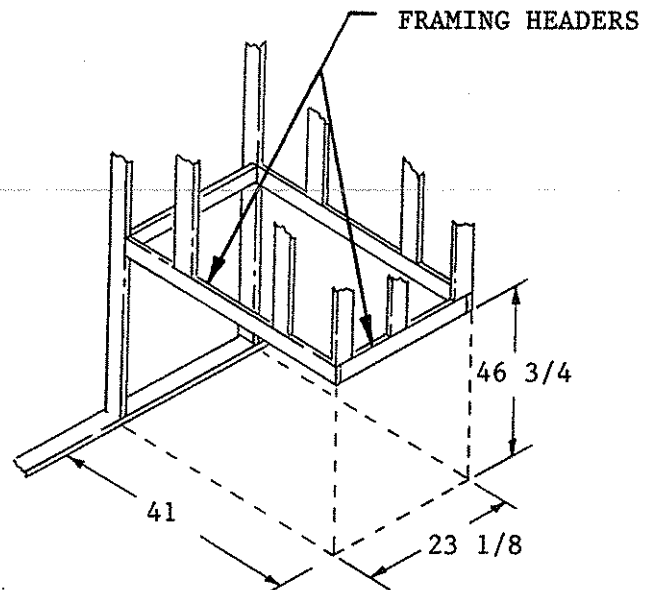

**MINIMUM DIMENSIONS**

**FIGURE 3**

MODEL PIER-GDV &  
PIER-DVT

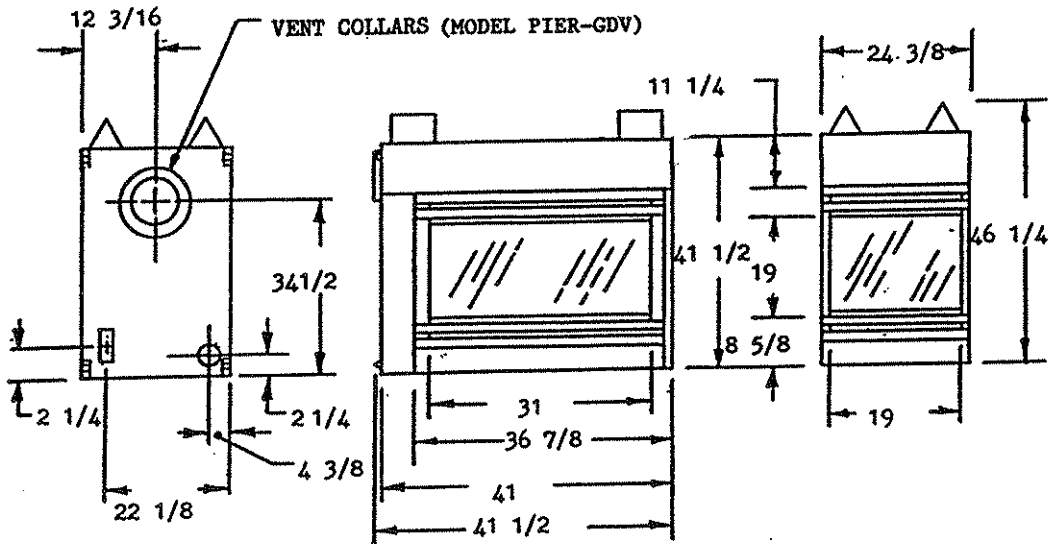
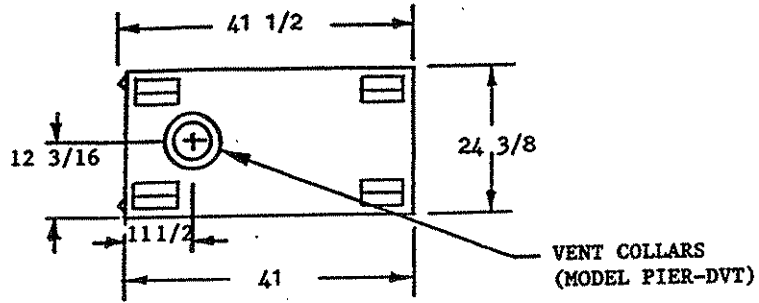

MODEL ST-DVT

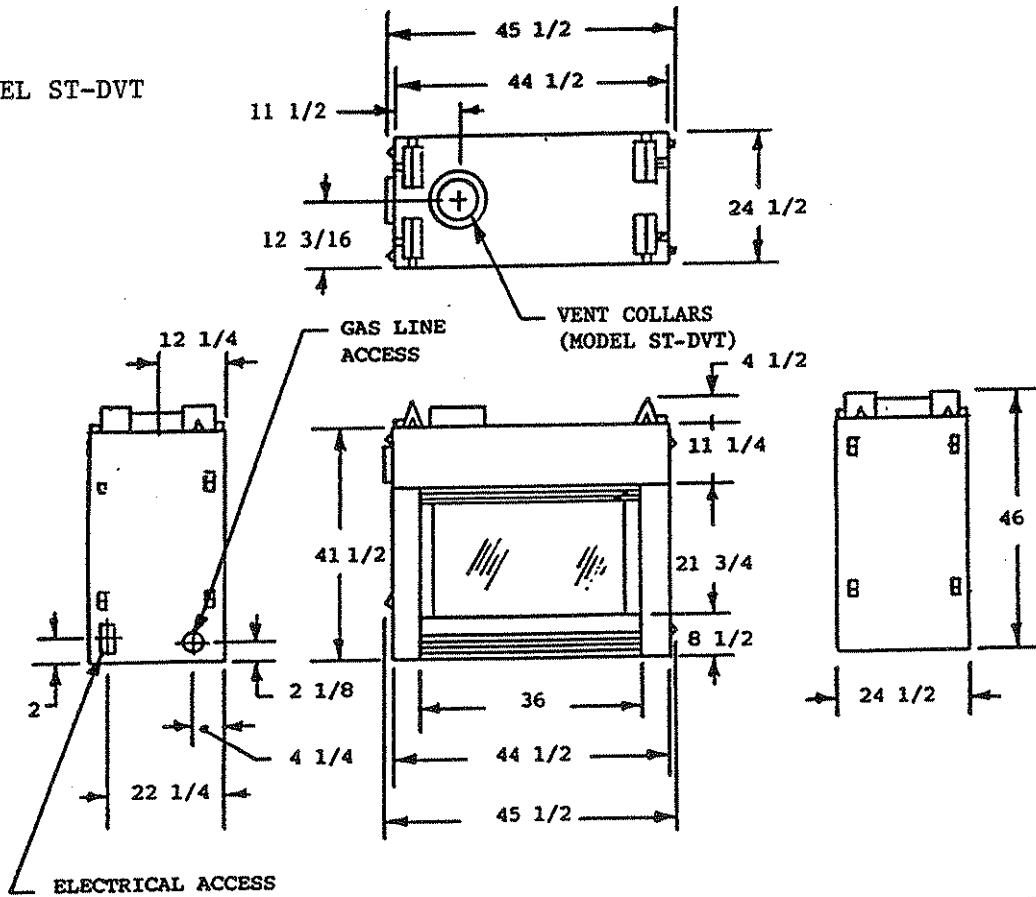

FIGURE 4



MODEL	VENT TERMINATION KIT APPROVALS				
ST-DVT, PIER-GDV, PIER-DVT	DVK-01D DVK-01TRD	DVK-02D DVK-02TRD	DVK-01SD	DVK-02SD	DVK-TVCD

**TABLE 1**

The fireplace can be mounted on any of the following surface:

1. A flat combustible surface other than carpeting.
2. A raised wooden platform.
3. Four (4) corner supports.

(Example: Four (4) concrete masonry blocks). These supports must be positioned so they contact all four (4) perimeter edges on the bottom of the unit.

If the fireplace is installed directly on carpeting, tile, or other combustible material other than wood flooring, the appliance shall be installed on a metal or wood panel extending the full width and depth of the unit.

Fireplace framing can be built before or after the fireplace is set in place. Framing should be positioned to accommodate wall covering and fireplace facing material. The fireplace framing should be constructed of 2 X 4 lumber or heavier. The framing headers may rest on the fireplace standoffs. Refer to Figure 3 and Figure 4 for fireplace and framing dimensions reference dimensions. **NOTE:** Check actual dimensions and verify finished wall material thicknesses **before** framing.

### 3.1 VENT SYSTEM APPROVALS

This model is approved to use D-Series direct vent pipe components.

Tables 1 through 5 and Figures 5 through 8 show the vent termination kits and vent systems approved for use with this Model. Approved vent system components are labeled for identification. **NO OTHER VENTING SYSTEMS OR COMPONENTS MAY BE USED.** Detailed installation instructions are included with each vent termination kit and should be used in conjunction with this manual.

#### STRAIGHT OUT HORIZONTAL VENTING

Table 2 and Figure 5 show the maximum straight out horizontal vent approvals for use on Model PIER-GDV.

Figure 5 also shows the maximum straight up vertical venting approvals for Models PIER-DVT and ST-DVT.

#### ELBOWS

The vent systems installed on this gas fireplace may also include one (1), two (2), or three (3) 90-degree elbow assemblies. The following relationships of vertical rise to horizontal run in vent configurations using 90-degree elbows **MUST** be strictly adhered to.

**NOTE: 45 DEGREE ELBOWS (DV-45D) MAY BE USED IN PLACE OF 90 DEGREE ELBOWS.**

#### ONE (1) 90-DEGREE ELBOW

Figure 6 and Table 3 show examples of possible installations using one (1) 90-degree elbow. Dimension V is listed as **MINIMUM** vertical dimensions and dimension H is listed as corresponding **MAXIMUM** horizontal dimensions. Vertical dimensions are based on centerline to centerline of pipe. Horizontal dimensions are based on back of the unit to centerline of pipe.

If straight sections of vent pipe are first attached to the unit, there must be at least a 1-foot vertical rise for each 2-feet of horizontal run. The maximum vertical rise is 40-feet, and the maximum horizontal run is 8-feet.

#### TWO (2) 90-DEGREE ELBOWS

Figure 7 and Table 4 show examples of possible installations using two (2) 90-degree elbows. Dimension V is listed as **MINIMUM** vertical dimensions, dimension H is listed as **MAXIMUM** beginning horizontal dimensions, and dimension H+H1 is listed as corresponding **TOTAL MAXIMUM** horizontal dimensions. Vertical dimensions are based on centerline to centerline of pipe. Horizontal dimensions H are based on back of unit to centerline of pipe. Horizontal dimensions H1 are based on centerline of pipe to end of termination.

Elevated vent systems using two (2) 90-degree elbows, **MUST** have at least a 1-foot vertical rise for each 2-feet of horizontal run. The **MAXIMUM** vertical rise is 20-feet, the **MAXIMUM** beginning horizontal run H is 8-feet, and the **MAXIMUM TOTAL** horizontal run H+H1 is 16-feet.

### THREE (3) 90-DEGREE ELBOWS

Figure 8 and Table 5 show examples of possible installations using three (3) 90-degree elbows. Dimension V is listed as **MINIMUM** first vertical dimensions, dimension H is listed as **MAXIMUM** beginning horizontal dimensions, and dimension H+ H1 is listed as corresponding **TOTAL MAXIMUM** horizontal dimensions.

Elevated vent systems using three (3) 90-degree elbows, **MUST** have at least a 1-foot vertical rise for each 2-feet of horizontal run. The **TOTAL MAXIMUM** vertical rise V+V1 is 40-feet, the **MAXIMUM** beginning horizontal run H is 8-feet, and the **TOTAL MAXIMUM** horizontal run H+H1 is 16-feet.

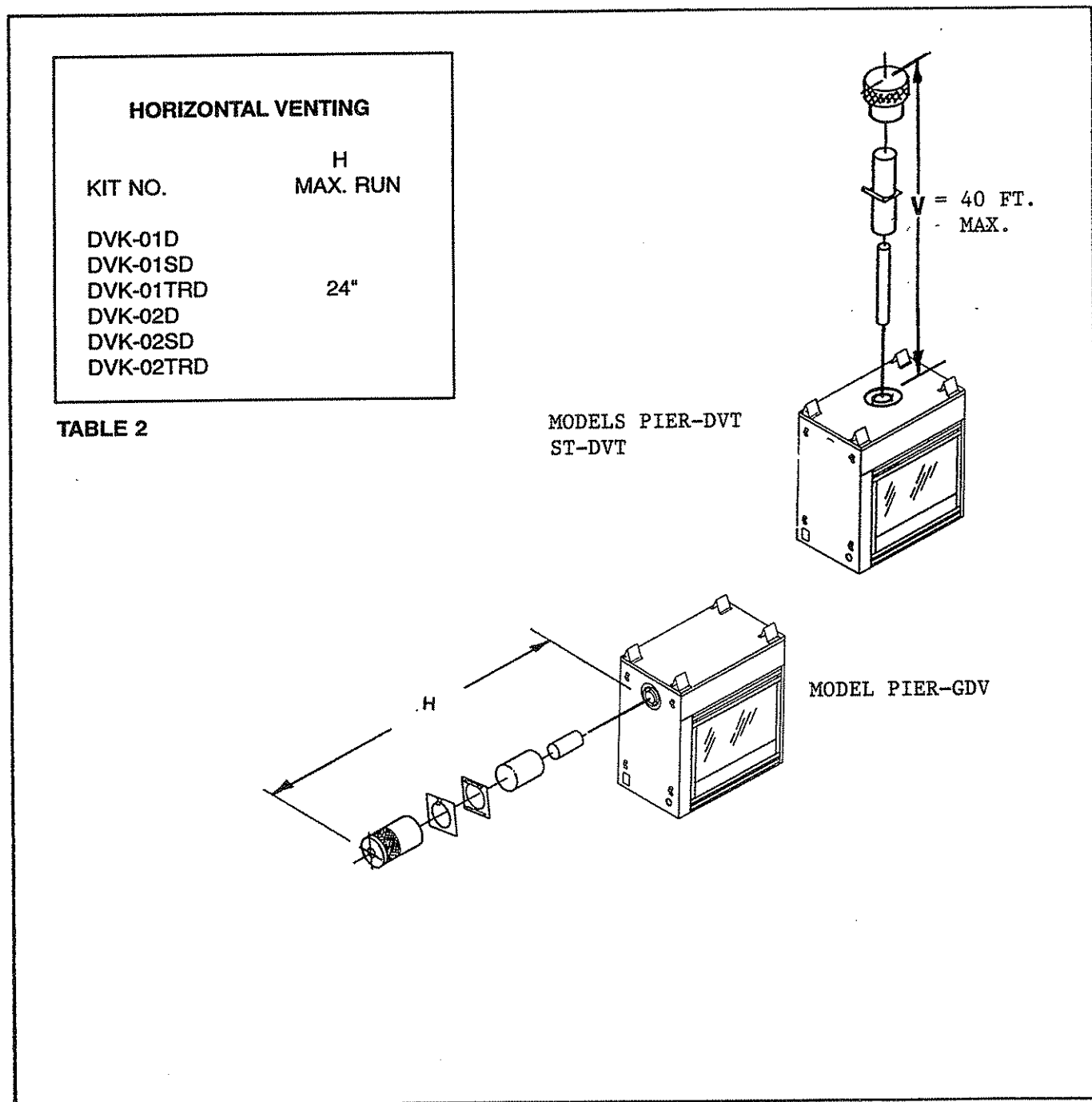

FIGURE 5

VENTING WITH ONE (1) 90° ELBOW	
V (FT.)	H (FT.)
1' MINIMUM	2' MAXIMUM
2' MINIMUM	4' MAXIMUM
3' MINIMUM	6' MAXIMUM
4' MINIMUM	8' MAXIMUM
5' MINIMUM	8' MAXIMUM
40' MAXIMUM	8' MAXIMUM

TABLE 3

MODEL PIER-GDV

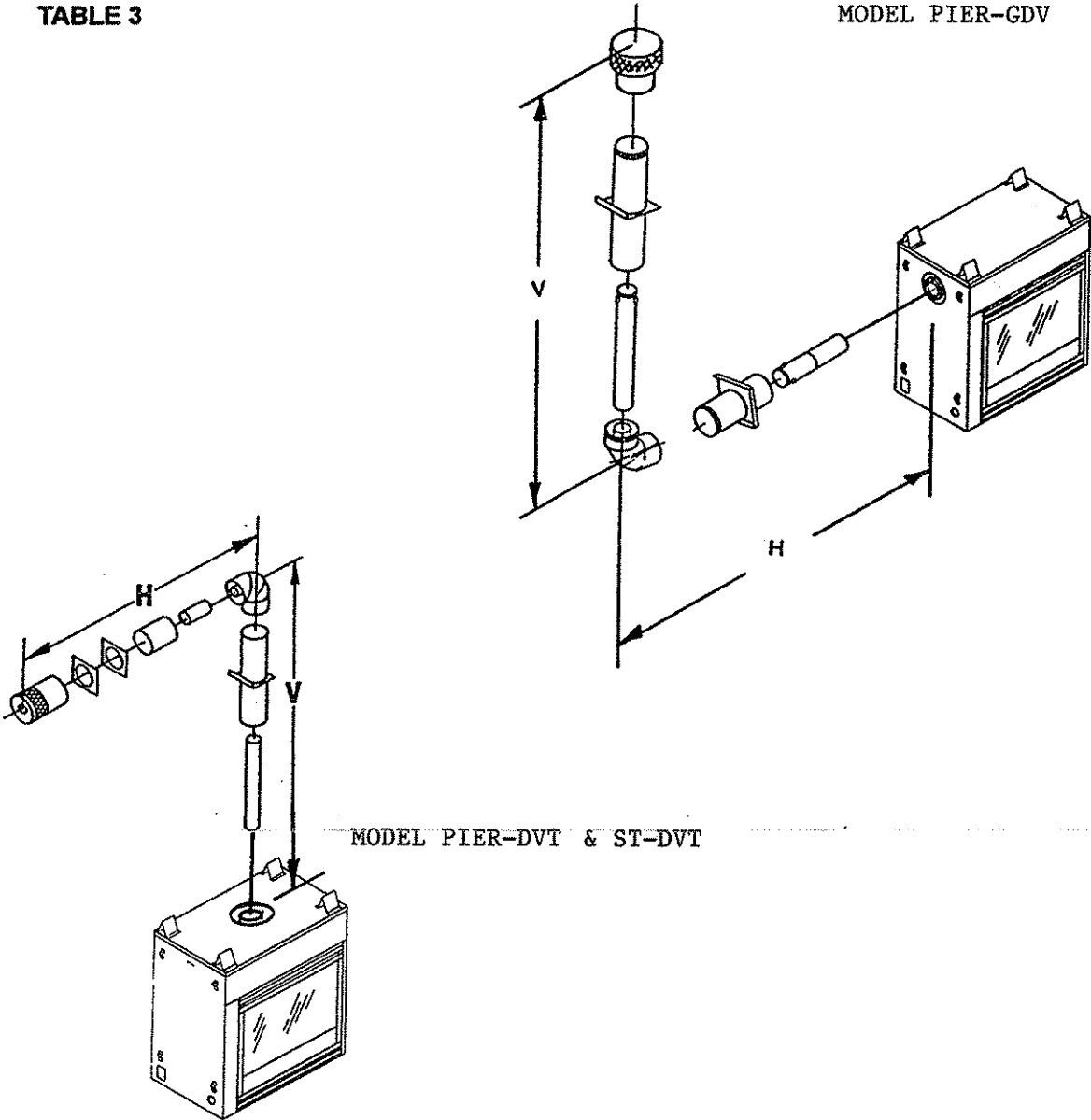

FIGURE 6

VENTING WITH TWO (2) 90° ELBOWS		
V (FT.)	H (FT.)	H + H1 (FT.)
1' MIN.	2' MAX.	2' MAX.
2' MIN.	4' MAX.	4' MAX.
3' MIN.	6' MAX.	6' MAX.
4' MIN.	8' MAX.	8' MAX.
5' MIN.	8' MAX.	10' MAX.
6' MIN.	8' MAX.	12' MAX.
7' MIN.	8' MAX.	14' MAX.
8' MIN.	8' MAX.	16' MAX.
9' MIN.	8' MAX.	16' MAX.
20' MAX.	8' MAX.	16' MAX.

TABLE 4

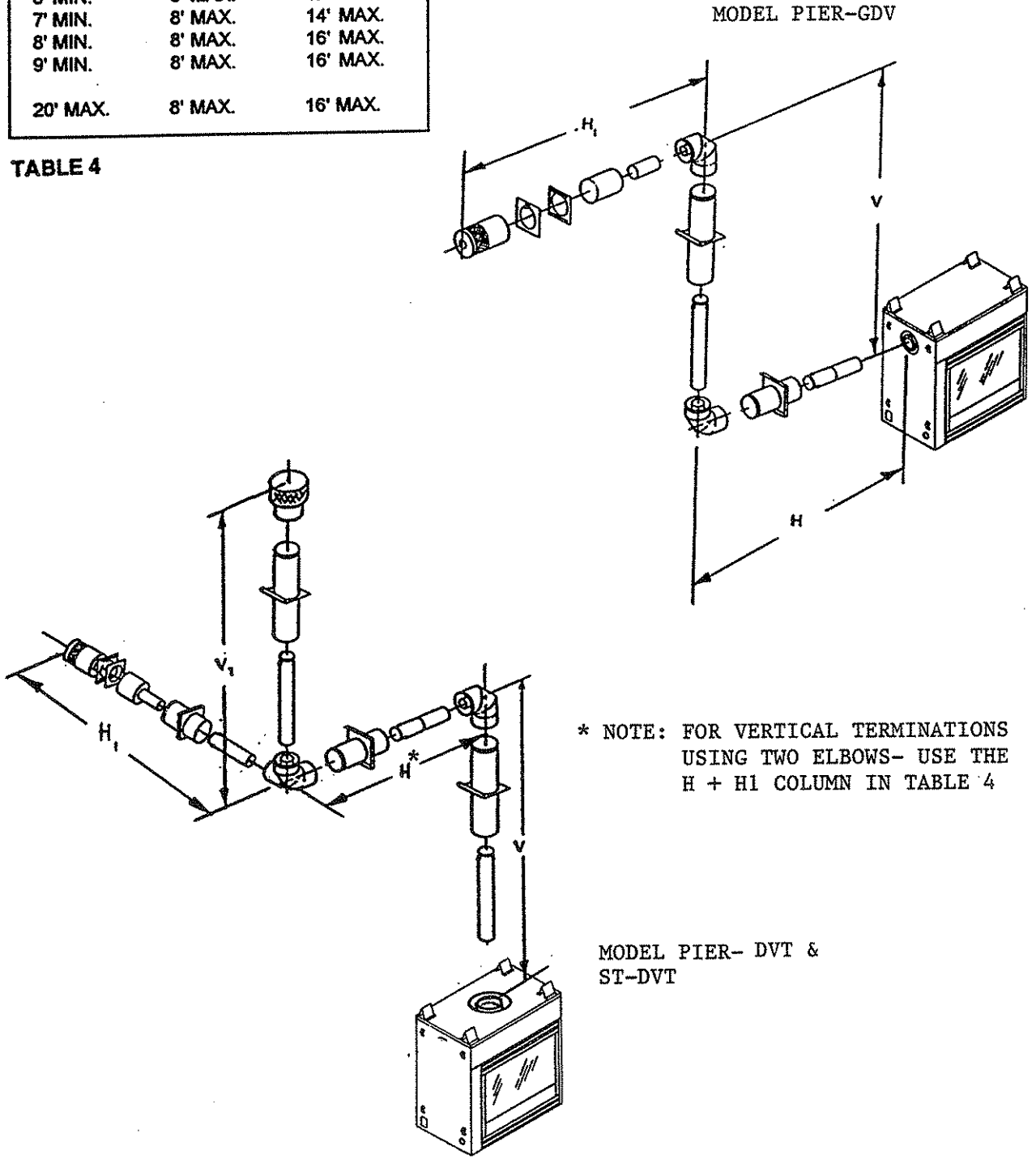

FIGURE 7

**VENTING WITH THREE (3) 90° ELBOW**

V (FT.)	H (FT.)	H + H1 (FT.)
1' MIN.	2' MAX.	2' MAX.
2' MIN.	4' MAX.	4' MAX.
3' MIN.	6' MAX.	6' MAX.
4' MIN.	8' MAX.	8' MAX.
5' MIN.	8' MAX.	10' MAX.
6' MIN.	8' MAX.	12' MAX.
7' MIN.	8' MAX.	14' MAX.
8' MIN.	8' MAX.	16' MAX.
9' MIN.	8' MAX.	16' MAX.
	8' MAX.	16' MAX.

NOTE: V + V1 MAXIMUM 40'

TABLE 5

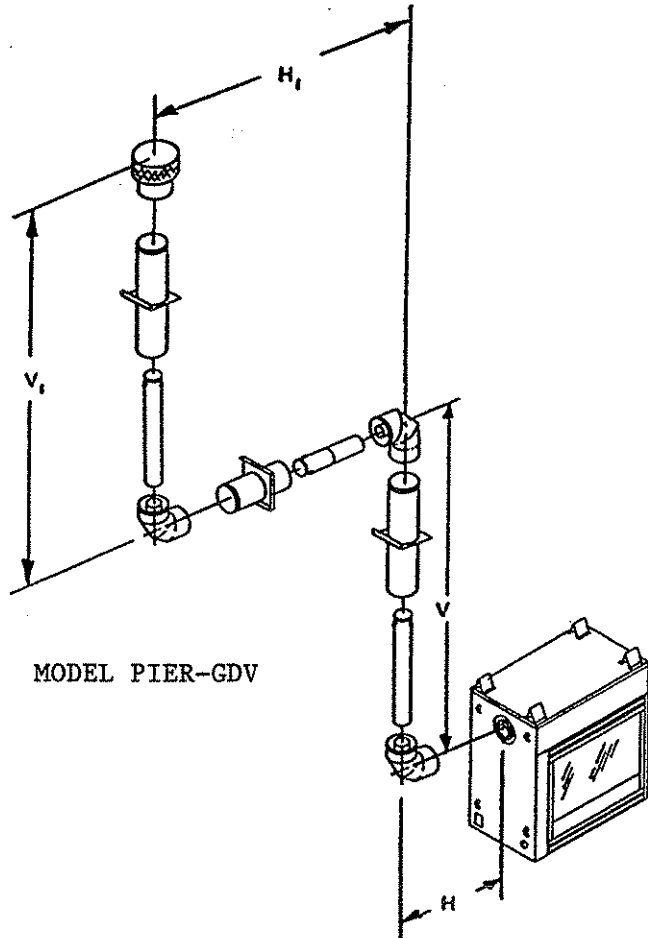

MODEL PIER-GDV

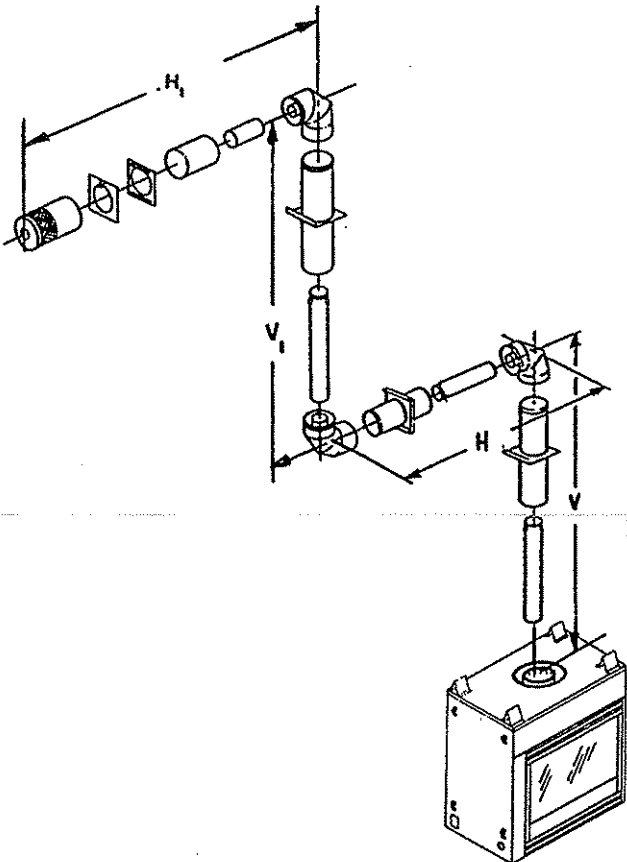

MODEL PIER-DVT & ST-DVT

### 3.2 VENT SYSTEM INSTALLATION PRECAUTIONS

Before starting installation of vent kits, the installer should read the Gas Fireplace Instructions and the D-Series Vent Kit Instructions to insure that the proper vent system has been selected for the installation.

Determine the exact position of the fireplace so the direct vent pipe is centered (if possible) between two building framing members. This will avoid any extra framing. Using a level, make sure the fireplace is properly positioned and squared. The 1/2 inch stand-offs on the sides and back of the fireplace may be positioned directly against combustible walls.

Consult your local Building Codes before beginning the installation.

**WARNING:** THIS GAS FIREPLACE AND VENT ASSEMBLY MUST BE VENTED DIRECTLY TO THE OUTSIDE AND MUST NEVER BE ATTACHED TO A CHIMNEY SERVING A SEPARATE SOLID FUEL BURNING APPLIANCE. EACH GAS APPLIANCE MUST USE A SEPARATE VENT SYSTEM-COMMON VENT SYSTEMS ARE PROHIBITED.

**CAUTION:** UNDER NO CONDITION SHOULD COMBUSTIBLE MATERIAL BE CLOSER THAN 3 INCHES (2 1/2 INCHES AT WALL FIRESTOPS) FROM THE TOP OF THE 8 5/8-INCH PIPE OR 1-INCH TO THE SIDES AND THE BOTTOM FOR HORIZONTAL SECTIONS OF THIS VENT SYSTEM. VERTICAL SECTIONS OF THIS SYSTEM REQUIRE A MINIMUM OF 1-INCH CLEARANCE TO COMBUSTIBLE MATERIALS ALL AROUND THE 8 5/8-INCH PIPE.

#### 3.2.1 INSTALLING THE VENT SYSTEM IN A CHASE

A chase is a vertical box-like structure built to enclose the gas appliance and/or its vent system. Vertical vents that run on the outside of a building may be, but are not required to be, installed inside a chase.

**CAUTION:** Treatment of firestop spacers and construction of the chase may vary with the type of building. These instructions are not substitutes for the requirements of local building codes. Therefore, your local building codes **MUST** be checked to determine the requirements for these steps.

**NOTE:** When installing this vent system in a chase, it is always good building practice to insulate the chase as you would the outside walls of your home. This is especially important for cold climate installations. Upon completion of building your chase framing, install the vent system by following the instructions in this manual. Remember to build the chase large enough so that minimum clearance of combustible materials (including insulation) to the vent system are maintained. **Be sure to maintain a 1 inch clearance (air space) between the vent pipe and all insulation materials.**

### 3.3 INSTALLING VENT SYSTEM COMPONENTS

Attach the first vent component to the starting collars of the fireplace.

**WARNING:** A 3/8-inch bead of stove cement **MUST** be placed around the 5-inch fireplace starting collar before attaching the first vent component. Failure to seal this joint, may cause the fireplace to not operate properly.

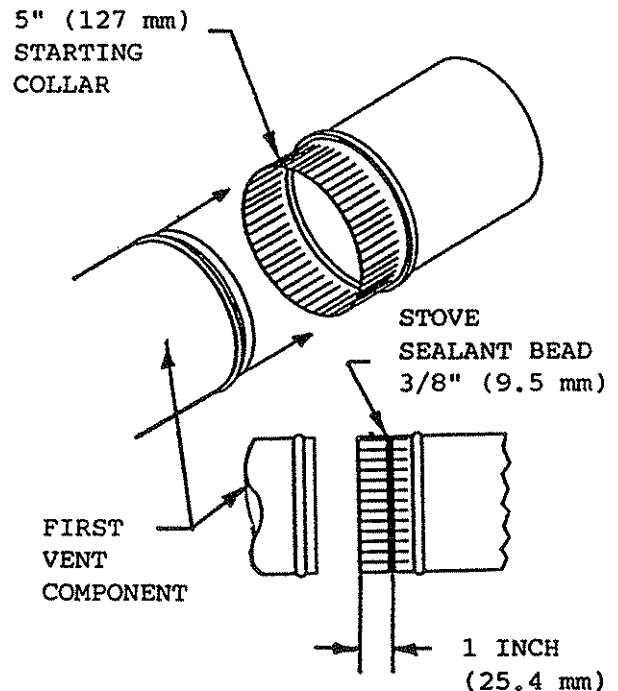

All vent system components lock into place by sliding the concentric pipe section with four (4) equally spaced interior beads into the appliance collar or previously installed component end with four (4) equally spaced indented sections. When the internal beads of each starting 8 5/8-inch outer pipe line up, rotate the pipe section clockwise approximately 3 inches. The vent pipe is now locked together.

**WARNING:** MAKE CERTAIN THAT THE FIBER-GLASS ROPE GASKET SUPPLIED WITH THE FIREPLACE, SEALS BETWEEN THE FIRST COMPONENT AND THE OUTER FIREPLACE WRAP.



90 degree elbows may be installed and rotated to any point around the preceding component's vertical axis. If an elbow does not end up in a locked position with the preceding component, attach with a minimum of two (2) sheetmetal screws.

Continue adding components per the pre-planned vent system configuration. Be certain that each succeeding vent component is securely fitted and locked into the preceding component in the vent system.

### 3.3.1 INSTALLING SUPPORT BRACKETS

A horizontal pipe support (DV-HPSD) **MUST BE** used for each 5 feet of horizontal run. The pipe supports should be placed around 8 5/8-inch diameter pipe and nailed in place to framing members. There **MUST** be a 3-inch clearance to combustibles above 8 5/8-inch diameter pipe and elbows and 1-inch clearance on both sides and bottom of 8 5/8-inch to combustibles on all horizontal pipe sections and elbows.

Vertical runs of this vent system must be supported every 4 feet above the fireplace flue outlet by wall brackets (DV-WBD) attached to the 8 5/8-inch vent pipe and secured with nails or screws to structural framing members. See Figure 9.

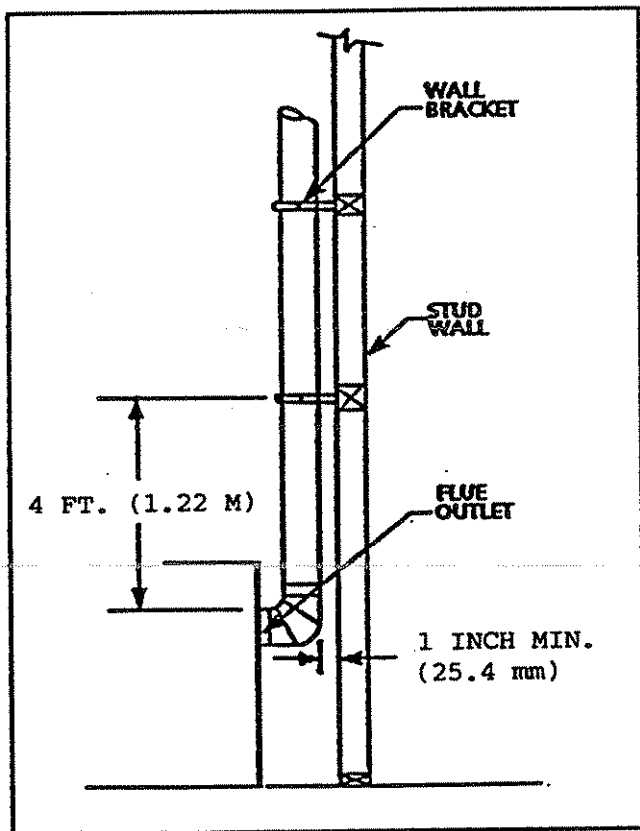

FIGURE 9

### 3.3.2 INSTALLING FIRESTOPS

Firestops are required for safety whenever the vent system passes through an interior wall, an exterior wall, or a ceiling. These firestops act as a firebreak, heat shield, and as a means to insure that minimum clearances are maintained to the vent system.

Horizontal runs in the vent system which pass through either interior or exterior walls, require the use of wall firestops (DV-FWD) on both sides of the wall through which the vent passes.

Cut a 12-inch X 12-inch hole through the wall-the center of the hole is 1-inch above the center of the horizontal vent pipe. See Figure 10.

Position the firestops on both sides of the 12-inch x 12-inch hole, previously cut. Secure with nails or screws. The heat shields of the firestops **MUST** be placed towards the top of the hole. (See Figure 11.) Continue the vent run through the firestops.

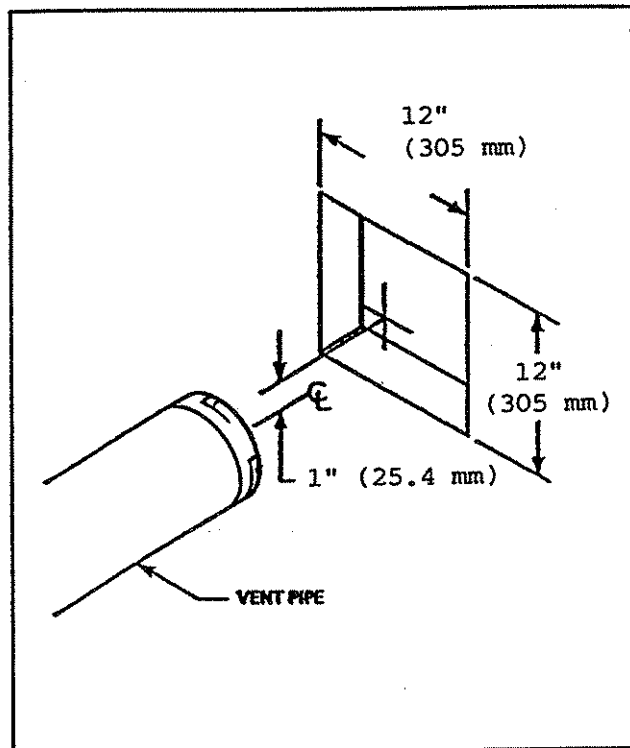

FIGURE 10

Vertical runs of this vent system which pass through ceilings require the use of one (1) ceiling firestop (DV-FCD) at the hole in each ceiling through which the vent passes.

Position a plumb bob directly over the center of the vertical vent component and mark the ceiling to establish the center point of the vent. Drill a hole or drive a nail through this center point and check the floor above for any obstructions such as wiring or plumbing runs. Reposition the fireplace and vent system, if necessary, to accommodate ceiling joists and/or obstructions.

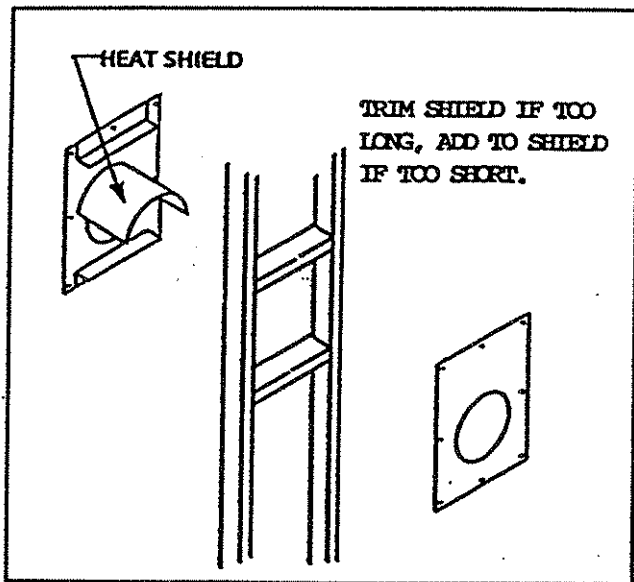

FIGURE 11

Cut an 11-inch X 11-inch hole through the ceiling, using the center point previously marked. Frame the hole with framing lumber the same size as the ceiling joists. See Figure 12.

If the area above the ceiling is NOT an attic, position and secure the ceiling firestop (DV-FCD) on the ceiling side of the previously cut and framed hole. (See Figure 13.) If the area above the ceiling IS an attic, position and secure the firestop on top of the previously framed hole. (See Figure 14.)

**NOTE:** Remove the insulation from the framed area in the attic before installing the firestop and/or vent pipes.

**WARNING:** INSULATION MUST BE AT A 1-INCH MINIMUM CLEARANCE TO THE VENT PIPE AND MUST NEVER CONTACT THE PIPE.

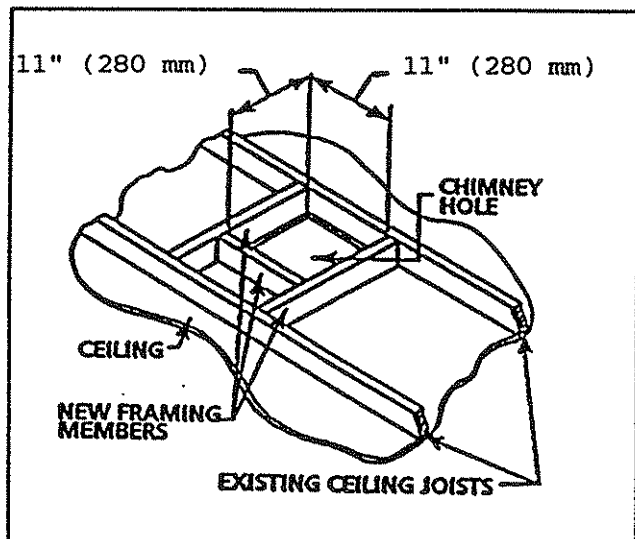

FIGURE 12

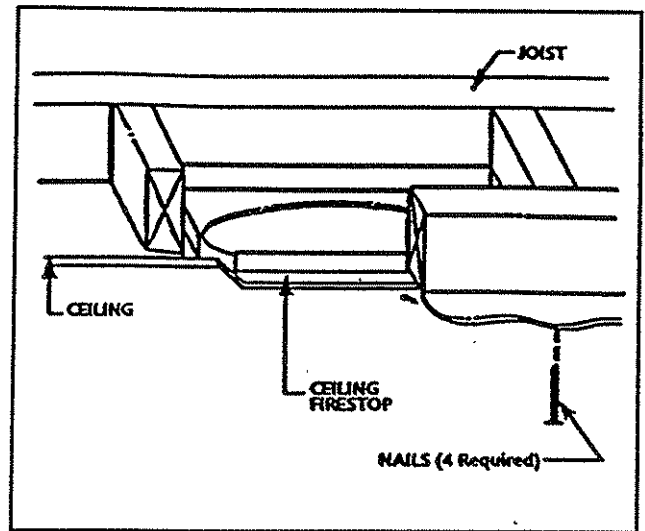

FIGURE 13

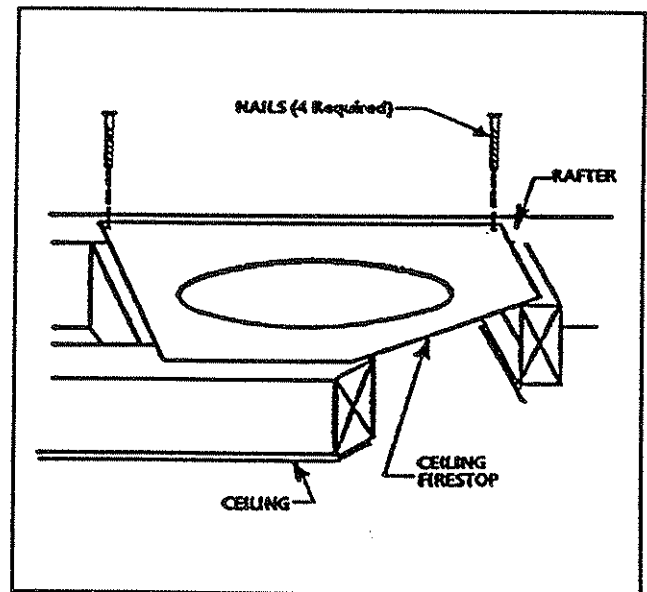

FIGURE 14

### 3.4 HORIZONTAL TERMINATIONS

DVK-01D, DVK-02D, DVK-01TRD, DVK-02TRD, DVK-01SD and DVK-02SD are telescoping vent kits which are used to terminate a vent system in a horizontal position. DVK-01D and DVK-02D have pre-assembled round termination caps. DVK-01SD and DVK-02SD have pre-assembled square termination caps. DVK-01TRD and DVK-02TRD have pre-assembled trapezoidal termination caps.

Attached and secure the termination to the last section of horizontal vent by rotating and interlocking the ends as previously described.

**NOTE:** The termination kit should pass through the wall firestops from the exterior of the building. Adjust the termination cap to its final exterior position on the building.

**NOTE:** The termination cap **MUST** be positioned so that the vent holes are on the bottom and the arrow is pointing **UP**. (See Figure 15.)

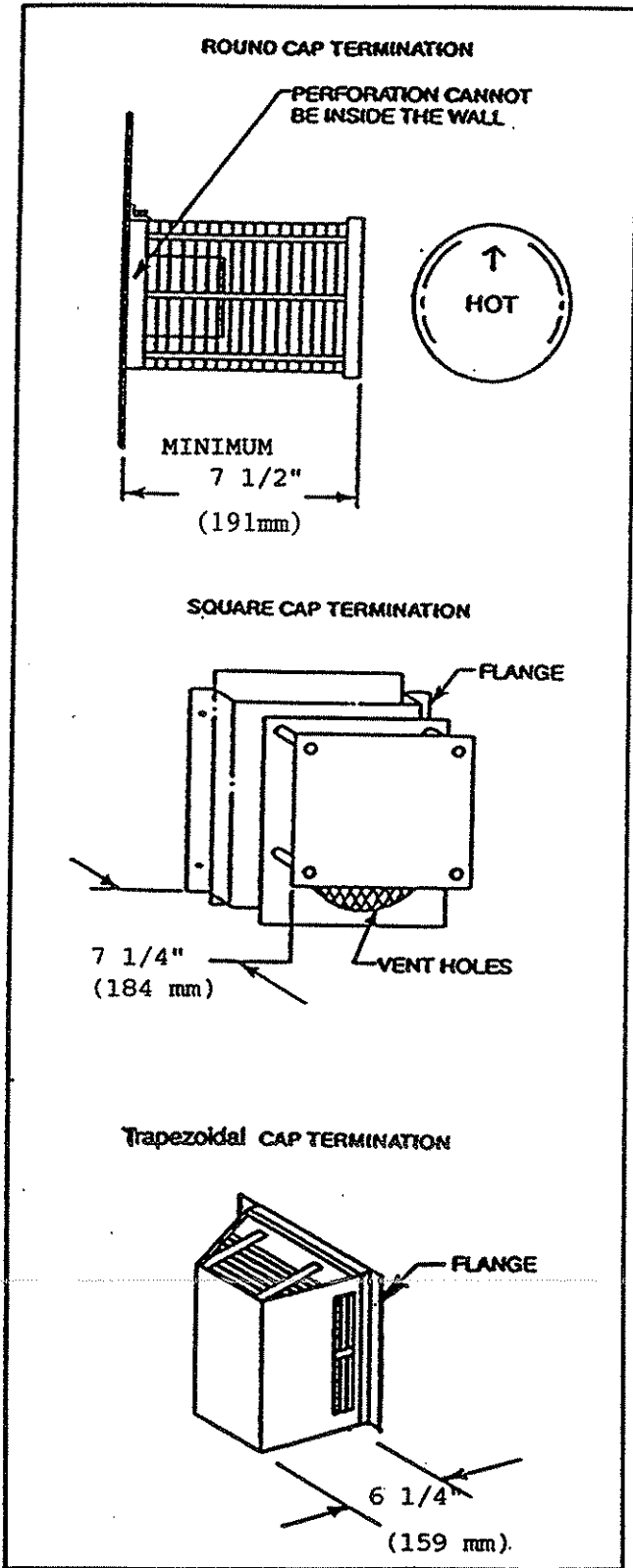

**FIGURE 15**

For round cap termination kits use the exterior pipelock hole provided on the round flange of the wall firestop (DV-FWD) to secure the 8 5/8-inch pipe in place. For square and trapezoidal cap termination kits, secure the cap with screws to the exterior wall through the flanges built into the cap. Use a high temperature fiberglass rope gasket to seal between the 8 5/8-inch pipe and exterior firestop.

**CAUTION:** Under **NO** condition should combustible material be closer than 3 inches (2 2 1/2 inches at wall firestops) from the top of the 8 5/8-inch pipe with a 1-inch clearance to the sides and bottom.

**WARNING:** The bottom of the vent termination cap must be a **MINIMUM** of 12-inches above ground level (grade), the top of the cap must be a **MINIMUM** of 24-inches below combustible material such as a deck and the side of the cap must be a **MINIMUM** of 6-inches away from a parallel outside wall. See Figure 16 for Vent Termination Clearances.

### 3.5 VERTICAL TERMINATIONS

A DVK-TVCD termination cap **MUST** be used to terminate a vent system in a vertical position.

#### 3.5.1 PENETRATING THE ROOF

Using the same procedure as described in Section 3.3.2, locate and mark the vent centerpoint on the underside of the roof and drive a nail through this centerpoint. Make the outline of the roof hole around the centerpoint nail.

**NOTE:** The size of the roof hole and hole framing dimensions depend upon the pitch of the roof. There must be a 1-inch clearance from the vent pipe to combustible materials. Mark the roof hole accordingly.

Cover the opening of the installed vent pipes and cut and frame the roof hole. Use framing lumber the same size as the roof rafters and install the frame securely. Flashing anchored to the frame must withstand heavy winds.

# VENT TERMINATION MINIMUM CLEARANCES FOR MODEL ST-DVT, PIER-GDV, AND PIER-DVT

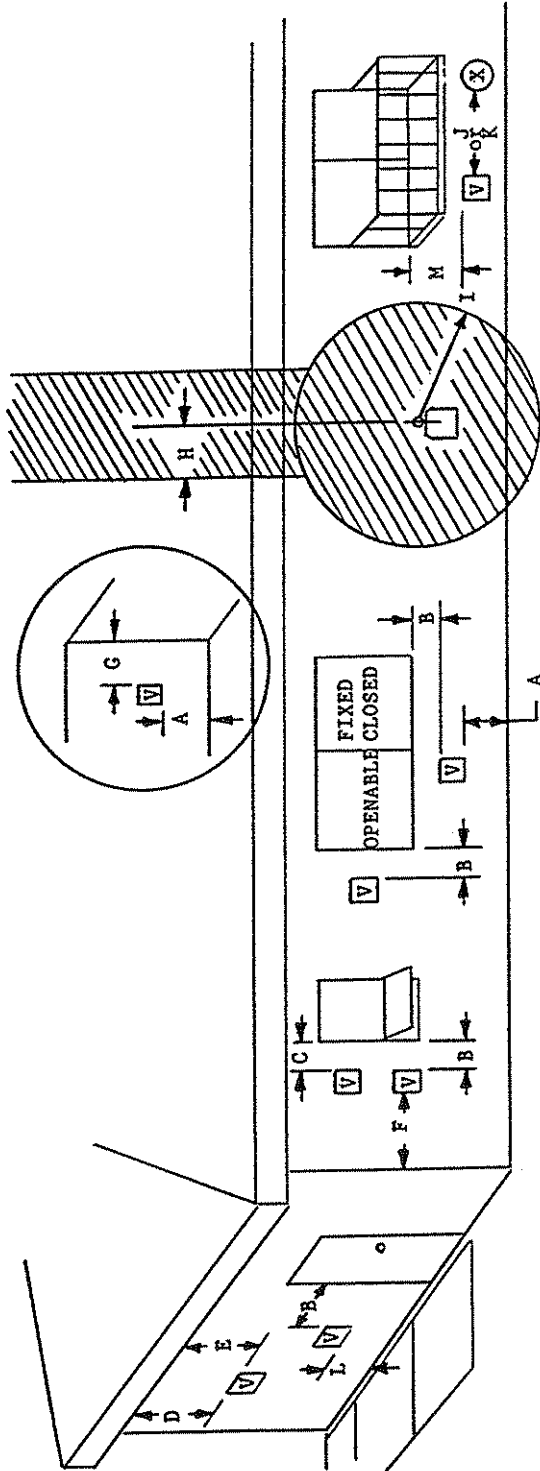

V = vent terminal    
 X = air supply inlet    
 = area where terminal is not permitted

- A = 12"
- B = 12"
- C = 9"
- D = 12"
- E = 24"
- F = 9"
- G = 6"

(U.S.A.)  
 (Canada)

clearances above grade, veranda, porch, deck or balcony  
 clearance to window or door that may be opened  
 clearance to permanently closed window

vertical clearance to ventilated soffit located above the terminal within  
 a horizontal distance of 2 feet (60 cm) from the centre-line of the terminal  
 clearance to unventilated soffit  
 clearance to outside corner  
 clearance to inside corner

- H = 3 feet
- I = 3 feet (U.S.A.)  
6 feet (Canada)
- J = 9" (U.S.A.)  
12" (Canada)
- K = 3 feet (U.S.A.)  
6 feet (Canada)
- \* L = 7 feet
- \*\* M = 24"

not to be installed above a meter/regulator assembly within 3 feet  
 (90 cm) horizontally from the centre-line of the regulator  
 clearance to service regulator vent outlet

clearance to non-mechanical air supply inlet to building or the combustion  
 air inlet to any other appliance  
 clearance to a mechanical air supply inlet

clearance above paved side-walk or a paved driveway located on public property  
 clearmace under veranda, porch, deck or balcony

\* a vent shall not terminate directly above a side-walk or paved driveway which is located between two single family dwellings and serves both dwellings.

\*\* only permitted if veranda, porch, deck or balcony is fully open on a minimum of 2 sides beneath the floor.

NOTE: local Codes or Regulations may require different clearances

FIGURE 16

### 3.5.2 MINIMUM VENT HEIGHT ABOVE THE ROOF

**WARNING:** Major U.S. building codes specify minimum chimney and/or vent height above the roof top. These minimum heights are necessary in the interest of safety. Figure 17 and Table 6 show minimum heights, provided the termination cap is at least 8-feet from a vertical wall.

**NOTE:** This also pertains to vertical vent system installed on the outside of the building.

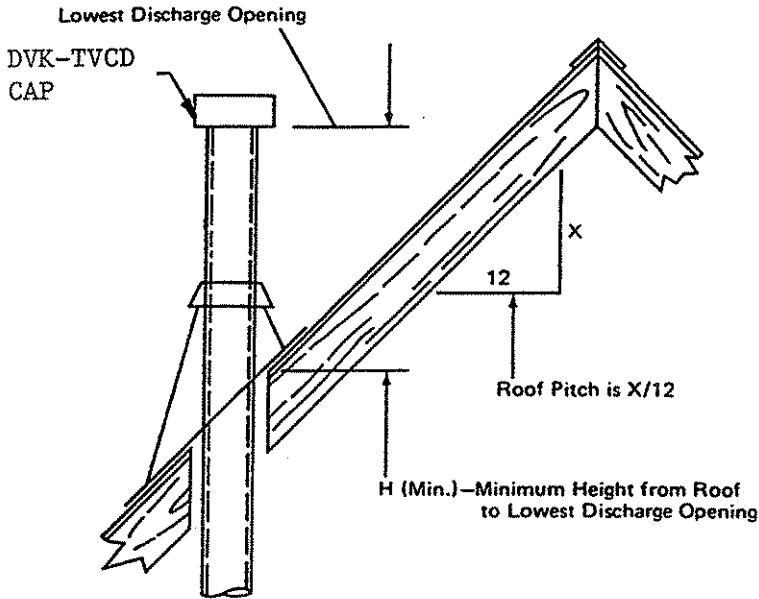

FIGURE 17

Roof Pitch	H (Min.) Ft.
Flat to 6/12	1.0
6/12 to 7/12	1.25
Over 7/12 to 8/12	1.5
Over 8/12 to 9/12	2.0
Over 9/12 to 10/12	2.5
Over 10/12 to 11/12	3.25
Over 11/12 to 12/12	4.0
Over 12/12 to 14/12	5.0
Over 14/12 to 16/12	6.0
Over 16/12 to 18/12	7.0
Over 18/12 to 20/12	7.5
Over 20/12 to 21/12	8.0

TABLE 6

Continue to install concentric 8 5/8-inch diameter vent sections up through the roof hole (inside vent installation) or up past the roof line (outside vent installation) until you reach the appropriate distance above the roof.

Install an 8 5/8-inch diameter flashing (to seal the roof hole) and an 8 5/8-inch diameter storm collar (to divert rain and snow away from the vent system). The flash-

ing should be nailed to the roof. A non-hardening mastic should be used around the edges of the flashing base where it meets the roof. The storm collar is then placed over this joint to make a water-tight seal. Non-hardening mastic is placed around the joint between the storm collar and the vertical pipe.

Slide the termination cap (Model DVK-TVCD) over the ends of the vent pipe and rotate clockwise. (See Figure 18.)

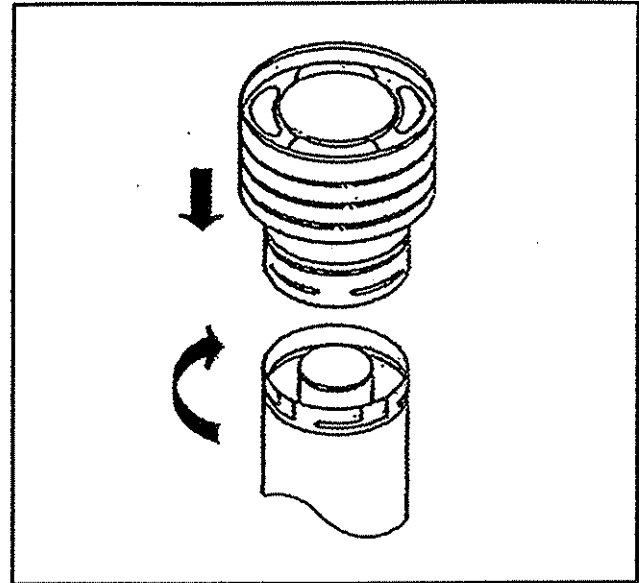

FIGURE 18

### 3.6 PERMANENTLY ANCHORING THE FIREPLACE

To prevent the unit from shifting, the fireplace must be anchored. Two methods are possible: use the nailing tabs as shown in Figure 19, or use the standoffs on the top of the fireplace. A nail may be driven through or a screw inserted through the framing headers into the top standoffs as shown in Figure 19.

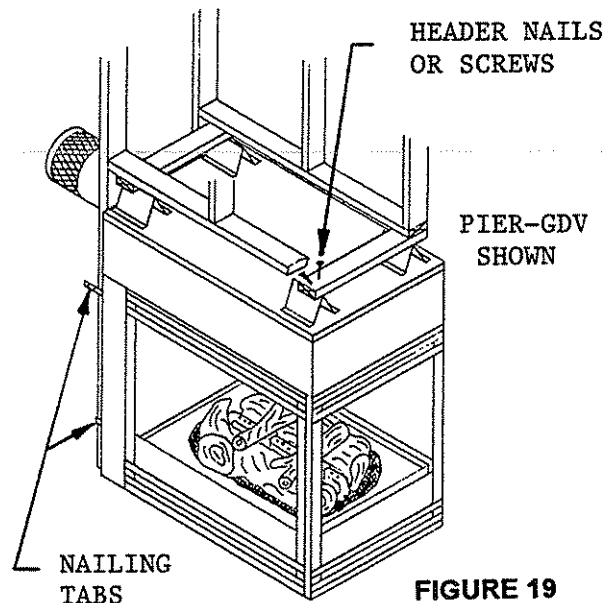

FIGURE 19

### 3.7 CONNECTING THE GAS LINE

The gas fireplace is designed to accept a 1/2-inch gas line for a listed gas appliance. Have the gas line installed by a qualified service person in accordance with all building codes. Consult local building codes to properly size the gas supply line leading to the 1/2-inch hook-up at the unit.

A listed 1/2-inch manual shut-off valve and a swivel nut fitting are connected to the 3/8-inch inlet of the control valve. A 1/8 inch N.P.T. plugged tapping, accessible for test gauge connection, should be provided for in the gas supply line leading to the unit's shut-off valve.

Locate the gas line access hole in the rear outer casing of the fireplace (Figure 20). Next, insert the gas pipe through the gas line hole from the outside of the fireplace and connect it to the gas valve. Support the control when attaching the pipe so that the pilot line is not bent or torn. After the gas pipe installation is complete, check carefully all gas connections for leaks with a soap solution. **DO NOT USE AN OPEN FLAME.** Use insulation to repack the space around the pipe. This should be inserted from the outside of the fireplace and packed tightly to totally seal between the pipe and the outer casing.

**NOTE:** THE GAS PIPE SHOULD NOT COME IN CONTACT WITH ANY WOOD STRUCTURES UNTIL IT HAS REACHED A POINT AT LEAST 1 INCH AWAY FROM THE FIREPLACE SIDE.

**NOTE:** THE GAS SUPPLY LINE SHOULD BE PURGED OF ANY TRAPPED AIR PRIOR TO THE FIRST FIRING OF THE UNIT.

### 3.8 ELECTRICAL WIRING FOR OPTIONAL KITS

These models have factory installed Electrical Junction Boxes which are used **ONLY** for wiring in optional kits.

An optional blower kit (GFK-160A) and hand held remote control kit (RCH-09A) are available. Use of these options requires that the Junction Box (factory installed) be connected to 110 VAC service before permanently enclosing the fireplace. The access hole for connecting the 110 VAC service wires is found on the lower rear exterior side of the unit. See Figure 21.

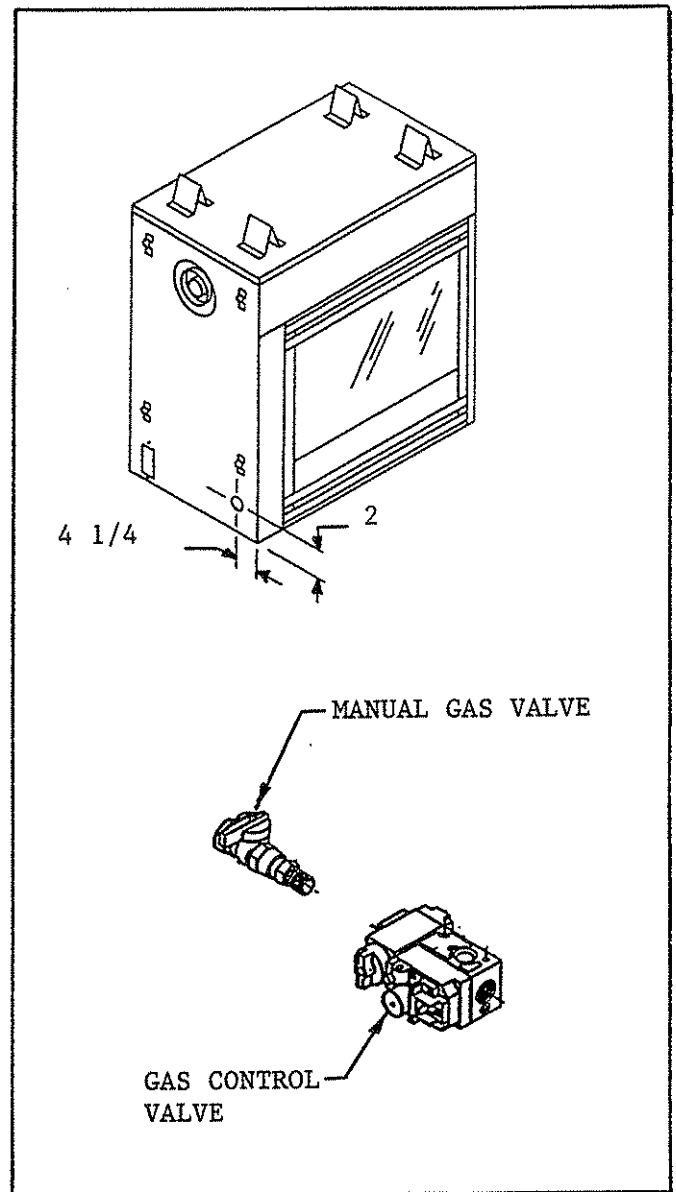

FIGURE 20



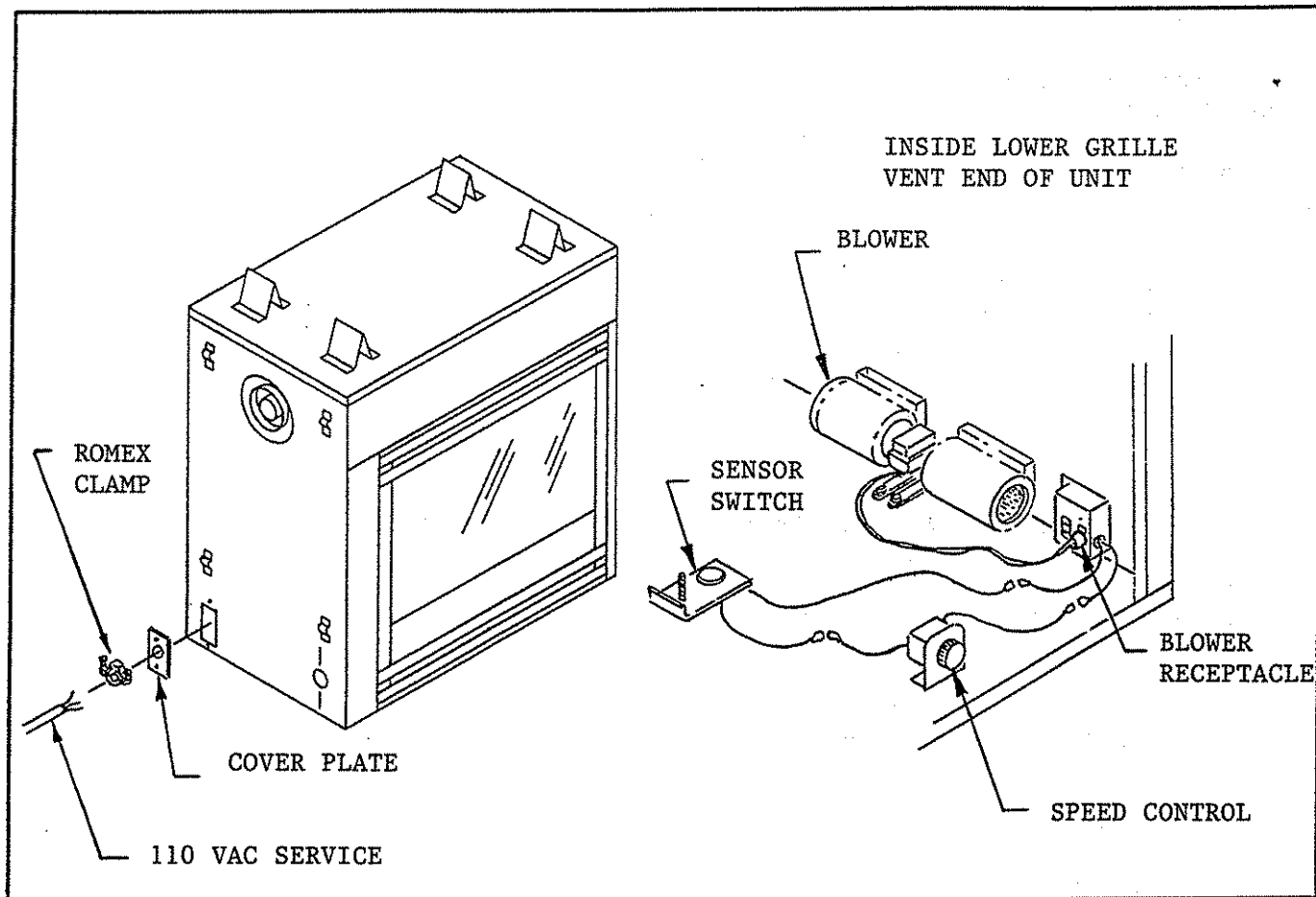

FIGURE 21

### 3.8.1 INSTALLING ELECTRICAL SERVICE TO THE JUNCTION BOX

**WARNING: TURN ELECTRICAL POWER OFF AT THE CIRCUIT BREAKER BEFORE BEGINNING INSTALLATION.**

1. Remove the electrical cover plate from the lower rear of the fireplace. Remove the knockout from the plate and attach the Romex clamp (screws to the outside).
2. Feed the electrical service wires through the Romex clamp and secure the wires to the clamp.
3. Using the wire nuts provided, connect the service wires to the Junction Box. The black wire to the black service wire, the white wire to the white service wire, and the service ground wire to the ground stud of the Junction Box.

4. Re-attach the cover plate to the outside of the fireplace.

Detailed instructions for the optional blower and the optional remote kits are included with each kit.

**WARNING: DO NOT CONNECT 110-120 VAC TO THE GAS CONTROL VALVE.**

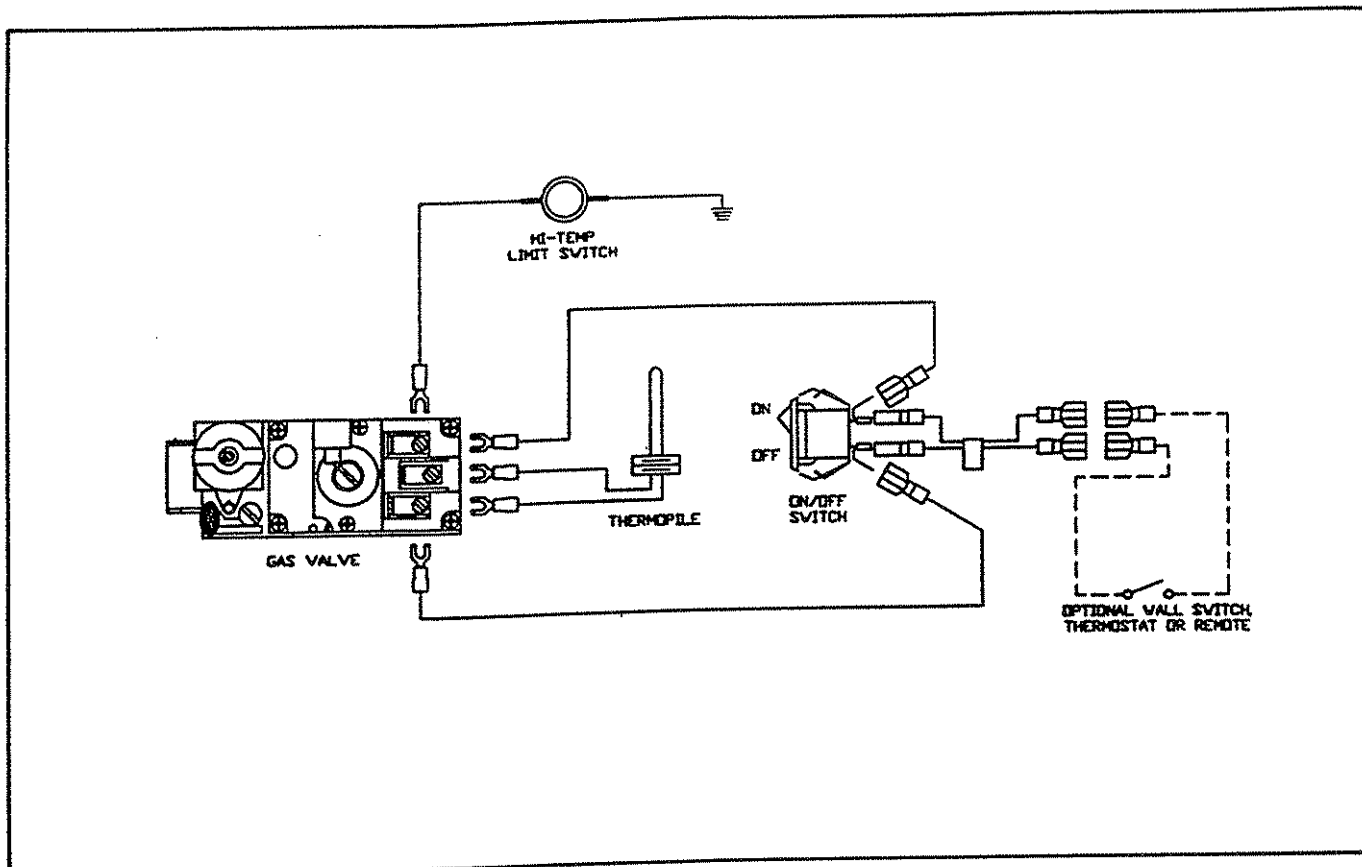

FIGURE 22

### 3.9 WALL SWITCH WIRING

A Wall Switch Kit (WSK-21) for turning the fireplace ON/OFF is included with the unit. This kit does NOT require 110 VAC. Connect the low voltage wires from the wall switch to the red and brown pigtail wires from the ON/OFF rocker switch. These wires are labeled "FOR REMOTE OR WALL SWITCH ONLY". Turn the unit's ON/OFF rocker switch to the "OFF" position to use the wall switch. See Figure 22 - Unit Wiring Diagram.

**NOTE: POSITION THE WALL SWITCH SO THAT A MAXIMUM OF 25 FEET OF WIRING FROM THE SWITCH TO THE FIREPLACE IS USED.**

**WARNING: DO NOT CONNECT 110-120 VAC TO THE GAS CONTROL VALVE OR CONTROL WIRING SYSTEM OF THIS MODEL.**

### 3.10 FINISHING

Finish the walls with the material of your choice. Figure 23 shows the minimum vertical and corresponding maximum horizontal dimensions of mantles or other combustible projections above the top front edge of the fireplace.

When finishing the fireplace NEVER OBSTRUCT OR MODIFY THE AIR INLET/OUTLET GRILLES IN ANY MANNER.

**CAUTION:** ALL JOINTS BETWEEN THE FINISHED WALL AND THE FIREPLACE SURROUND (TOP AND SIDES) CAN ONLY BE SEALED WITH NON-COMBUSTIBLE MATERIAL. ONLY NON-COMBUSTIBLE MATERIAL CAN BE APPLIED AS FACING TO THE FIREPLACE SURROUND. SEE FIGURE 24.

DO NOT put any finishing material on the Vent Cap. DO NOT extend a combustible overhang more than 1- 1/2 inches beyond the exterior wall itself, unless the overhang is at least 24 inches above the cap (See Figure 16).

### 3.11 HEARTH EXTENSION

While a hearth extension may be desirable for aesthetic reasons, it is not required for decorative gas appliances per ANSI or CAN/CGA testing standards.

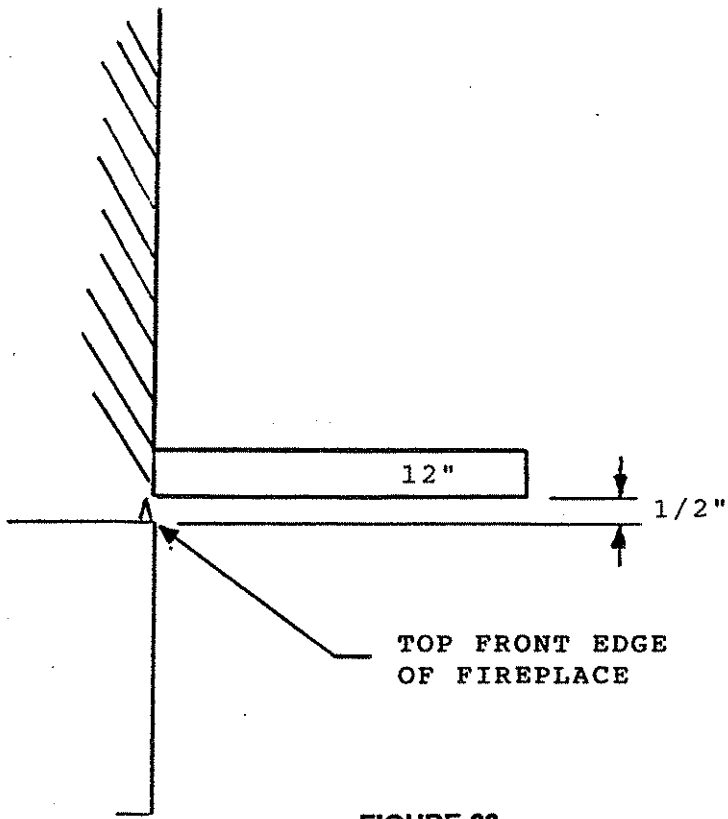

FIGURE 23

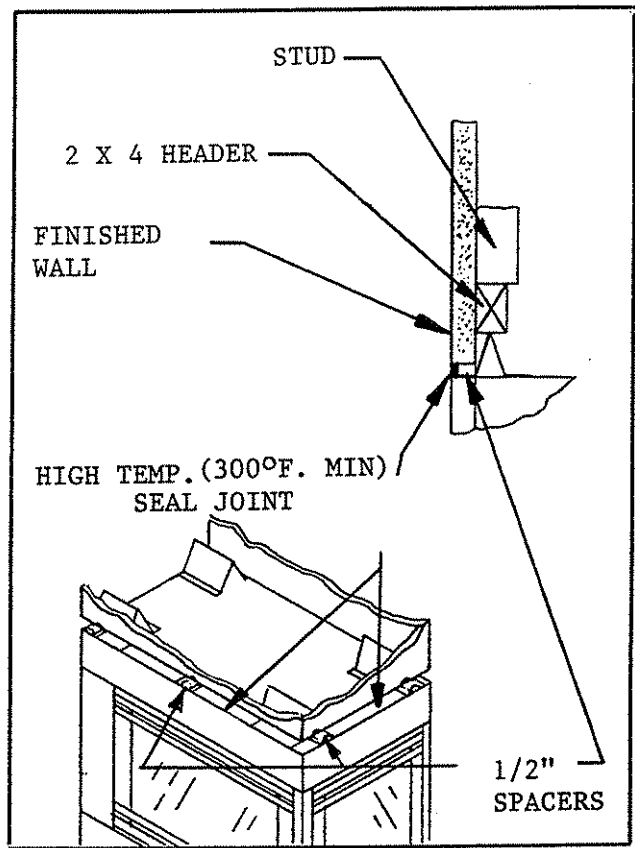

FIGURE 24

#### 4.0 ELECTRICAL SAFETY SYSTEM

**WARNING: DO NOT CONNECT 110-120 VAC TO THE GAS CONTROL VALVE OR CONTROL WIRING SYSTEM OF THIS MODEL.**

The gas control system is wired so the thermopile, when heated with the pilot light, will provide approximately 350 to 500 millivolts. This activates the gas control valve. Additionally, a high temperature limit switch is wired to ground and will shut-off the pilot and burner should a high surface temperature condition

occur. The pilot and main burner must be re-lit when the fireplace cools. See Figure 25 and Figure 22-Unit Wiring Diagram.

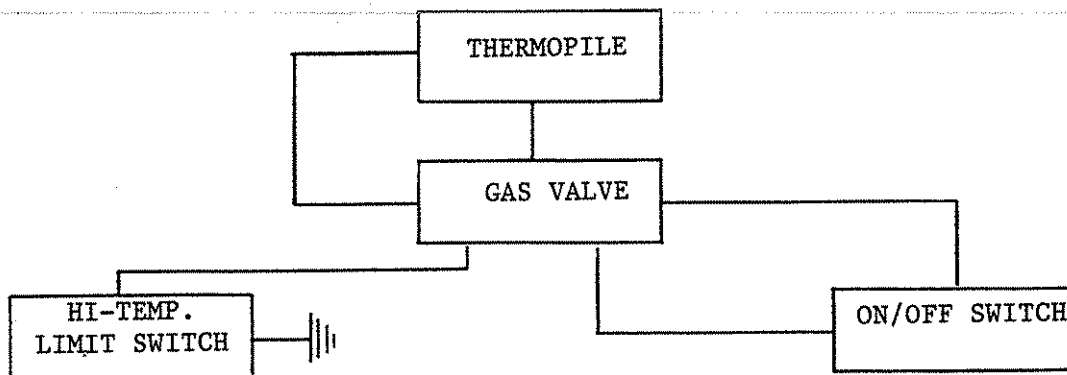

FIGURE 25

## 5.0 OPERATING GUIDELINES MAINTENANCE INSTRUCTIONS

Upon completing the gas line connection, a small amount of air will be in the lines. When first lighting the pilot light, it will take a few minutes for the lines to purge themselves of this air. Once the purging is complete, the pilot and burner will light and operate as indicated in the Instruction Manual.

Subsequent lightings of the appliance will not require such purging.

**CAUTION:** DURING THE INITIAL PURGING AND SUBSEQUENT LIGHTING'S **NEVER** ALLOW THE GAS VALVE CONTROL KNOB TO REMAIN DEPRESSED IN THE "PILOT" POSITION WITHOUT PUSHING THE RED IGNITOR BUTTON AT LEAST ONCE EVERY SECOND.

When lit for the first time, the appliance will emit a slight odor for an hour or two. This is due to paint and lubricants used in the manufacturing process. Additionally, for the first few minutes after each lighting, vapor may condense and fog the glass and the flames may be blue. After a few minutes this moisture will disappear and within 15-30 minutes the flames should become yellow.

The fireplace may produce a noise, caused from metal expansion and contraction as it heats up and cools down. This noise is similar to one that a furnace or heat duct may produce and does not affect the operation or longevity of the fireplace.

Keep the control compartment, logs, and burner area surrounding the logs clean by vacuuming or brushing at least twice a year.

**CAUTION:** THE LOGS CAN GET VERY HOT - HANDLE ONLY WHEN COOL.

Always turn off gas to the pilot before cleaning. For relighting, refer to lighting instructions located behind the lower front trim assembly.

The appliance and venting system should be inspected before initial use and at least annually by a qualified field service person.

Always keep the appliance area clear and free from combustible materials, gasoline, and other flammable vapors and liquids.

Never obstruct the flow of combustion and ventilation air. Keep the front of the appliance clear of all obstacles and materials.

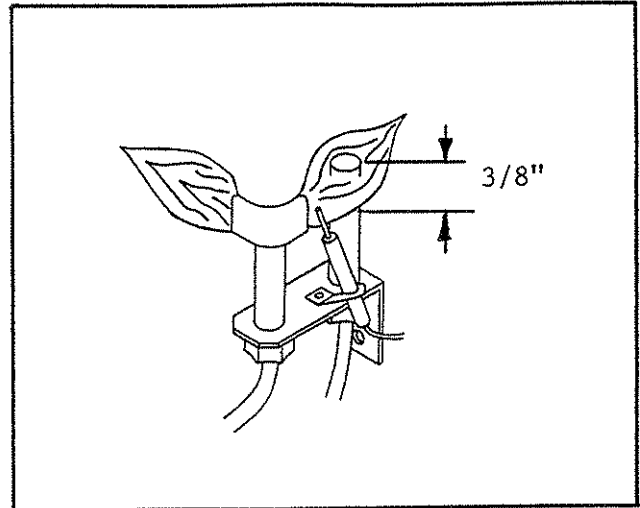

FIGURE 26

To obtain proper operation, it is imperative that the pilot and main burner flame characteristics are steady, not lifting or floating. Typically, the top 3/8-inch at the pilot thermopile should be engulfed in the pilot flame (Figure 26).

**WARNING:** CHILDREN AND ADULTS SHOULD BE ALERTED TO THE HAZARDS OF HIGH SURFACE TEMPERATURE AND SHOULD STAY AWAY TO AVOID BURNS OR CLOTHING IGNITION. YOUNG CHILDREN SHOULD BE SUPERVISED WHEN THEY ARE IN THE SAME ROOM AS THE APPLIANCE.

**IMPORTANT:** TURN OFF GAS BEFORE SERVICING APPLIANCE. IT IS RECOMMENDED THAT A COMPETENT SERVICE TECHNICIAN PERFORM THESE CHECK-UPS AT THE BEGINNING OF EACH HEATING SEASON.

**WARNING:** DO NOT USE ABRASIVE CLEANERS ON THE GLASS DOOR ASSEMBLIES. DO NOT ATTEMPT TO CLEAN THE GLASS DOORS WHEN THEY ARE HOT.

Inspect the external vent cap on a regular basis to make sure that no debris is interfering with the air flow.

### 5.1 GLASS DOOR REMOVAL

1. To remove the front or rear large glass door, you must remove the trim front doors by lifting them up off the retainer pins on the end trim door and pulling them away from the unit. Remove the top and bottom brass corner trim pieces by sliding them out of the brass trim strips on the trim doors, before attempting to remove the trim doors. You must also remove the end trim door which is held in place by four mounting tabs. Lift the end trim door up until the bottom tabs are disengaged from their slots, lower the door, and remove it from the unit.

2. Noting carefully how the brackets fit on the glass, remove wing nuts and brackets from the glass door.

3. The glass door is now ready for removal.

## 5.2 CLEANING BURNER AND PILOT

In order to properly clean the burner and pilot assembly, turn off the gas to the unit and remove the logs exposing the burner and pilot assembly.

Clean all foreign materials from top of burner. Check to make sure that burner orifice is clean.

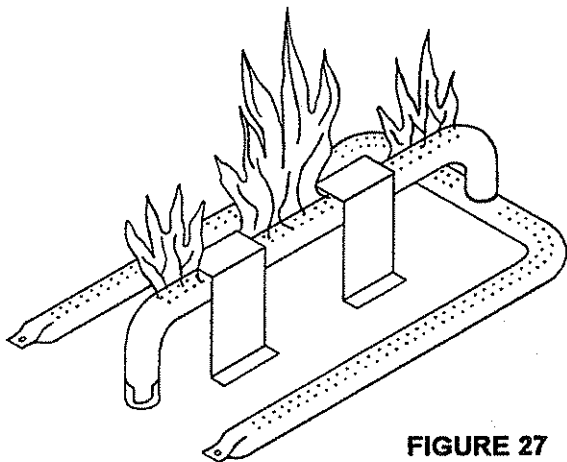

FIGURE 27

Visually inspect pilot periodically. Brush or blow away any dust or linen accumulations. If pilot orifice is plugged, disassembly may be required to remove any foreign material from orifice or tubing. When appliance is put back in service check burner flame patterns with Figure 27.

By design, the flame pattern will not be identical from unit to unit. Additionally, flame pattern may vary depending on installation type and weather conditions.

## 5.3 LOG REPLACEMENT

1. Remove the trim door and glass door assemblies (See Section 5.1).
2. The Log(s) can now be removed as required. Replace the log(s) as previously shown in Figure 2 - Gas Log Positioning. Replace glass door and trim door.

## 5.4 GLASS DOOR REPLACEMENT

1. Before replacing the glass doors make sure the vermiculite material is spread evenly over the bottom of the firebox and the logs are properly positioned.

2. Place the bottom edges of the large glass doors on the rubber spacers of the bottom mounting studs on the fireplace. Place the side edges of the doors against the rubber spacers of the mounting studs towards the venting end of the unit.

Center the small end glass door and place the bottom edge on the bottom mounting studs.

3. With glass doors in place push glass against unit and at the same time put brackets on upper portion of doors and tighten the wing nuts provided.
4. Attach the brackets at the sides and bottom of the glass and hand tighten.

**NOTE:** WING NUTS THAT SECURE THE GLASS ONLY NEED TO BE HAND TIGHTENED TO GIVE A SNUG FIT FOR PROPER GASKET SEAL. OVERTIGHTENING MAY RESULT IN DAMAGED GLASS.

5. Replace the trim door proceeding in reverse order of step 1 under Glass Door Removal.

**WARNING:** THE GLASS DOOR ASSEMBLIES MUST BE IN PLACE AND SEALED AND THE TRIM ASSEMBLIES MUST BE IN PLACE ON THE FIREPLACE BEFORE THE UNIT CAN BE PLACED INTO SAFE OPERATION.

## 6.0 SAFETY INFORMATION

### FOR YOUR SAFETY READ BEFORE LIGHTING

**WARNING: IF YOU DO NOT FOLLOW THESE INSTRUCTIONS EXACTLY, A FIRE OR EXPLOSION MAY RESULT CAUSING PROPERTY DAMAGE, PERSONAL INJURY, OR LOSS OF LIFE.**

A. This appliance has a pilot. When lighting the pilot, follow these instructions exactly.

B. BEFORE LIGHTING smell all around the appliance area for gas. Be sure to smell next to the floor because some gas is heavier than air and will settle on the floor.

#### WHAT TO DO IF YOU SMELL GAS

- Do not try to light any appliance
- Do not touch any electric switch: do not use any phone in your building.
- Immediately call your gas supplier from a neighbor's phone. Follow the gas supplier's instructions.
- If you cannot reach your gas supplier, call the fire department.



C. Use only your hand to push in or turn the gas control knob. Never use tools. If the knob will not push in or turn by hand, don't try to repair it. Call a qualified service technician. Forced or attempted repair may result in a fire or explosion.

D. Do not use this appliance if any part has been under water. Immediately call a qualified service technician to inspect the appliance and to replace any part of the gas control system which has been under water.



## 7.0 LIGHTING INSTRUCTIONS

### LIGHTING INSTRUCTIONS

1. "STOP!" Read the safety information on previous page.
2. To access controls, rotate up the bottom panel of the trim assembly.
3. Turn the valve control knob to the "OFF" position. To do this, you must turn the knob clockwise  to the "Pilot" position, and then press in and continue turning clockwise  to the "OFF" position.

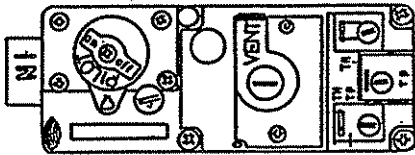

**GAS CONTROL VALVE**



**NOTE:** Knob cannot be turned from "PILOT" to "OFF" unless knob is pushed in slightly. Do not force.

4. WAIT FIVE (5) MINUTES TO CLEAR OUT ANY GAS. Then smell for gas, including near the floor. If you then smell gas, STOP! Follow "B" in the safety information above. If you don't smell gas, go to the next step.
5. The pilot should not require accessing for lighting purposes. The pilot is located inside the combustion chamber. If it is necessary to access the pilot, follow the instructions in Section 5.1 for glass door removal.

#### THERMOPILE

#### PILOT BURNER



6. To put the control in the "Pilot" position, turn the control knob counter-clockwise  to the "Pilot" position.
7. To light the pilot depress the control knob and then depress the red piezo button until it makes a clicking sound. It may be necessary to repeat this step. If the pilot does not light after 10 seconds, go back to step 3. The control knob should be held down for a MINUTE after pilot ignition.
  - If the control knob does not pop out when released, STOP-shut off the gas supply to the fireplace control valve, and IMMEDIATELY call your service technician or gas supplier.
  - If the pilot will not stay lit after two tries, turn the control knob to the "OFF" position and call your service technician or gas supplier.
8. After the pilot has been lit, the burner can be turned on by turning the knob counter-clockwise  to the "ON" position. Flip the ON/OFF switch to the "ON" position.
9. Close the bottom panel of the trim assembly by rotating it down.

### TO TURN OFF GAS APPLIANCE

1. Open the bottom panel of the mesh trim assembly.
2. Turn the On/Off switch to "OFF".
3. Turn the valve control knob clockwise  to the "Pilot" position, then depress knob and continue turning to "OFF" position.
4. Close the bottom panel of the trim assembly.

After the unit has warmed up (i.e. approx. 15 min.), flame height should be no higher than 2" below the top of the trim assembly (Figure 28). If the flame height is higher than this, adjustments must be made to prevent overheating the gasket and glass. Please contact your dealer or a qualified service person to replace the orifice or adjust the valve.

**NOTE: THE TOPS OF THE FLAMES SHOULD NEVER HIT THE TOP OF THE FIREBOX.**

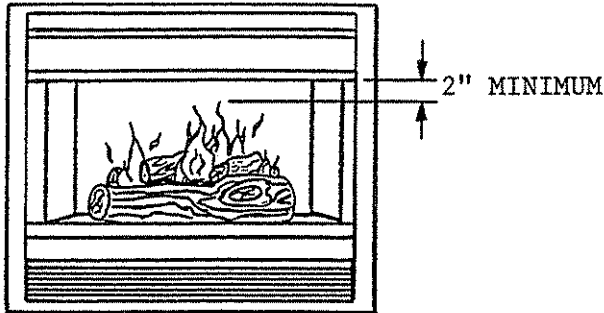

FIGURE 28

## LPG (PROPANE) WARNING

**THE FOLLOWING WARNING APPLIES TO INSTALLATIONS USING L.P. (PROPANE) GAS:**

**WARNING:** To avoid possible injury, fire and explosion, please read and follow these precautions and all instructions on this appliance before lighting the pilot. This appliance uses L.P. (Propane) gas which is heavier than air and will remain at floor level if there is a leak. Before lighting, smell at floor level and/or use other means (such as using a soap solution on all piping and connections, using a gas detector, etc.) to check for gas leaks. **NOTE:** L.P. (Propane) gas can become odorless and **CANNOT** always be detected by smell. If you smell gas, detect a gas leak, or suspect that a gas leak exists, follow these rules.

1. Get all people out of building.
2. **DO NOT** light matches. **DO NOT** turn electric lights or switches on or off in area. **DO NOT** use an electric fan to remove gas from area. **DO NOT** use a telephone inside the building.
3. Shut off gas at L.P. tank outside of building.
4. Telephone gas company and fire department from a neighbor's phone. Ask instructions.

Before hanging up, give your name, address, and phone number. **DO NOT** go back into building.

If your L.P. tank runs out of fuel, turn off gas at the appliance. After L.P. tank is refilled, appliance must be re-lit according to manufacturer's instructions. If the gas control has been exposed to WATER in any way, **DO NOT** try to use it. It must be replaced. **DO NOT** attempt repair on gas control or appliance.

Tampering is **DANGEROUS** and voids all warranties. Any component that is found to be faulty, must be replaced with an approved component.

## 8.0 HIGH ALTITUDE INSTALLATION

A.G.A. Design Certified units are tested and approved for elevations from 0-2000 feet. CGA approved units are certified for elevations from 0-4500 feet.

When installing this unit at an elevation above 2000 feet, (in United States) it may be necessary to decrease the input rating by changing the existing burner orifice to a smaller size. Input should be reduced 4 percent for each 1000 feet above sea level. Check with your local gas company for assistance in determining proper orifice size.

When installing this unit at an elevation between 2000-4500 feet (in Canada) the input rating must be reduced by 10 percent.

When installing this at an elevation above 4500 (in Canada), check with local authorities.

Consult your local gas company for assistance in determining the proper orifice for your location.

## 9.0 TROUBLE SHOOTING - PIER-GDV/PIER-DVT/ST-DVT

With proper installation and maintenance, your new Gas Fireplace should provide years of trouble-free service. If you do experience a problem, refer to the Trouble Shooting Guide below. This guide will assist a qualified service person in the diagnosis of problems and the corrective action to be taken.

SYMPTOM	POSSIBLE CAUSE	CORRECTIVE ACTION
<b>I. Spark Ignitor will not light pilot after repeated triggering of red button.</b>	A. Defective ignitor (no spark at electrode).	1. Check for spark at electrode and pilot; if no spark and electrode wire is properly connected, replace ignitor.
	B. Defective pilot or misaligned electrode (spark at electrode).	1. Using a match, light pilot. If pilot lights, turn off pilot and trigger the red button again. If pilot lights, an improper gas/air mixture caused the bad lighting and longer purge period is recommended. If pilot will not light - check gap at electrode and pilot - should be 1/8 inch to have a strong spark. If OK, replace pilot.
	C. No gas or low gas pressure.	1. Check remote shut off valves from fireplace. Usually there is a valve near the main. There can be more than one (1) valve between the fireplace and main.  2. Low pressure can be caused by a variety of situations such as a bent line, too narrow diameter of pipe or even low line pressure. Check for kinked lines. If none, consult with plumber or gas supplier.
	D. No L.P. in tank.	3. Check L.P. (propane) tank. You may be out of fuel.
<b>II. Pilot will not stay lit after carefully following lighting instructions.</b>	A. Defective thermopile.	1. Check pilot flame. Must impinge on thermopile. Clean and or adjust pilot for maximum flame impingement on thermopile.  2. Be sure wire connections from thermopile at gas valve terminals are tight and thermopile is fully inserted into pilot bracket.

SYMPTOM	POSSIBLE CAUSE	CORRECTIVE ACTION
<b>III. Pilot burning, no gas burner, valve knob "ON", "on-off" switch "ON".</b>	B. Open wire connection in pilot circuit.	1. Check wire continuity and connection in pilot circuit.
	C. Defective valve.	1. Turn green knob to pilot position, depress and light pilot light. If meter reading is less than 325 m.v. after 30 seconds, or if pilot does not stay lit, the valve is defective.
	A. "On-Off" switch or wires defective.	1. Check "on-off" switch and wires for proper connections. Place jumper wires across terminals at switch-if burner comes on, replace defective switch. If OK, place jumper wires across switch wires at gas valve-if burner comes on, wires are faulty or connections are bad.
	B. Thermopile may not be generating sufficient millivoltage. (325m.v.)	1. Recheck Symptom #2. 2. Pilot flame not physically close enough to thermopile.
	C. Defective valve.	1. Turn valve knob to "ON". Place ON/OFF switch to "ON". Check with millivolt meter at thermopile terminals. Millivolt meter should read greater than 125 m.v. If the reading is okay and the burner does not come on, replace the gas valve.
		3. Check thermopile with millivolt meter. Take reading at "TH-TP&TP" terminals of gas valve. Should read 325 millivolts minimum while holding valve knob depressed in pilot position, pilot lit, and on/off switch "OFF". Replace faulty thermopile if reading is below specified minimum.  4. Disconnect thermopile leads from the valve with pilot burner "ON", take reading at the thermopile leads - should 325 millivolts minimum. Replace thermopile if reading is below minimum.

SYMPTOM	POSSIBLE CAUSE	CORRECTIVE ACTION
IV. Frequent pilot outage problem.	D. Plugged burner orifice.	1. Check burner orifice for stoppage and remove.
	E. Wall switch or wires defective.	1. Follow corrective action in A.1 above; check switch and wiring. Replace where defective.
V. Pilot and main burner go out while being in operation.	A. Pilot flame may be too low or blowing (high), causing the pilot safety to drop out.	1. Clean and adjust pilot flame for maximum flame impingement on thermopile.
	A. High limit switch is defective or has reached its maximum temperature.	1. Allow unit to cool. Then repeat lighting instructions. If pilot and burner remain lit, after the fireplace warms up, the switch is good.  2. If 1 above does not allow for ignition, or the fireplace continues to shut-off, disconnect the limit switch wire from the gas valve and repeat lighting instructions. If the pilot and burner remain lit after the fireplace warms up, replace the limit switch. <b>Do not use the fireplace until the high limit switch is replaced and properly wired.</b>
	B. No L.P. in tank.	1. Check L.P. (Propane) tank. You may be out of fuel.
	C. Inner 5-inch pipe leaking exhaust gases back into system.	1. Check for leaks.
	D. Horizontal vent improperly pitched.	1. Horizontal vent should slope down only enough to prevent any water from entering unit. The maximum downward slope is 1/4" for any horizontal run.
	E. Glass too loose and air tight gasket leaks in corners after usage.	1. Tighten corner.
	F. Bad thermopile.	1. Replace if necessary.
	G. Improper vent cap installation.	1. Check for proper installation & freedom from debris or blockage.

SYMPTOM	POSSIBLE CAUSE	CORRECTIVE ACTION
<b>VI. Glass soots.</b>	A. Flame impingement.	1. Adjust the log set so that the flame does not impinge on it.
	B. Improper venturi setting.	1. Adjust the air shutter at the base of the burner.
	C. Vermiculite around venturi.	1. Inspect the opening in the vermiculite dam at the base of the burner. It is imperative that <u>NO</u> material be placed in this opening.
<b>VII. Flame burns blue and lifts off burner.</b>	A. Insufficient oxygen being supplied.	1. Check to make sure vent cap is installed properly and free of debris. Make sure that vent system joints are tight and have no leaks.  2. Check to make sure that the vermiculite has not been improperly placed in the vermiculite dam down at the burner base or in the area of the air holes in the center of the base pan beneath the burner.  3. Be sure glass is tightened properly on unit, particularly on top corners.



**11.0 DIRECT SPARK IGNITION  
FOR MODEL ST-DVT-DSI, PIER-GDV-DSI, AND PIER-DVT-DSI  
(PROPANE MODELS NOT FOR USE IN CANADA)**

This unit requires 110 VAC service in order to operate. Connection to house wiring should ONLY be done by a Qualified Electrician.

**FOR YOUR SAFETY READ BEFORE LIGHTING**

**WARNING: IF YOU DO NOT FOLLOW THESE INSTRUCTIONS EXACTLY, A FIRE OR EXPLOSION MAY RESULT IN PROPERTY DAMAGE, PERSONAL INJURY OR LOSS OF LIFE.**

- A. This appliance does not have a pilot. It is equipped with an ignition device which automatically lights the burner. Do not try to light the burner by hand.
- B. BEFORE LIGHTING smell all around the appliance area for gas. Be sure to smell next to the floor because some gas is heavier than air and will settle on the floor.
- C. Do not use this appliance if any part has been under water. Immediately call a qualified service technician to inspect the appliance and to replace any part of the control system and any gas control which has been under water.

**WHAT TO DO IF YOU SMELL GAS**

- Do not try to light any appliance.
- Do not touch any electric switch; do not use any phone in your building.
- Immediately call your gas supplier from a neighbor's phone. Follow the supplier's instructions.
- If you cannot reach your gas supplier, call the fire department.

**LIGHTING INSTRUCTIONS**  
**DSI CONTROLS**  
**(PROPANE MODELS NOT FOR USE IN CANADA)**

1. **STOP!** Read the safety information in the "For Your Safety Read Before Operating DSI Controls" section of this instruction.
2. Turn off all electric power to the appliance.
3. This appliance is equipped with an ignition device which automatically lights the burner. Do not try to light the burner by hand.
4. Wait five (5) minutes to clear out any gas. Then smell for gas, including near the floor. If you then smell gas, **STOP!** Follow "B" in the safety information located on the previous pages. If you don't smell gas, go to next step.
5. Turn on all electric power to the appliance.
6. Turn ON/OFF rocker switch to "ON".
7. If the appliance will not operate, follow the instructions "to Turn Off Gas to Appliance" and call service technician or gas supplier.

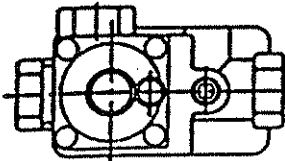

**GAS VALVE**

**TO TURN OFF GAS TO APPLIANCE**

1. Flip ON/OFF switch to "OFF".
2. Turn off all electric power to the appliance if service is to be performed.

## OPTIONAL SWITCH WIRING ST-DVT-DSI/PIER-GDV-DSI/PIER-DVT-DSI CONTROLS (PROPANE MODELS NOT FOR USE IN CANADA)

An optional Wall Switch (WSK-21) or Remote Control Switch (RCH-09A) may be wired to this appliance. The Wall Switch **DOES NOT** require a separate 110-120 VAC electrical service connection. The remote control receiver **DOES** require 110-120 VAC which is obtained at the pre-installed junction box. Connect wires from the optional switch installed to the accessory wires (labeled Optional Wall Switch or Remote). Set the unit's ON/Off rocker switch to the "OFF" position. Activate the optional switch installed to control the main burner of the unit. Detailed installation instructions for optional switches are found in each accessory kit.

**WARNING: DO NOT CONNECT A SEPARATE SOURCE OF 110-120 VAC TO AN OPTIONAL WSK-21 WALL SWITCH INSTALLED TO THIS FIREPLACE.**

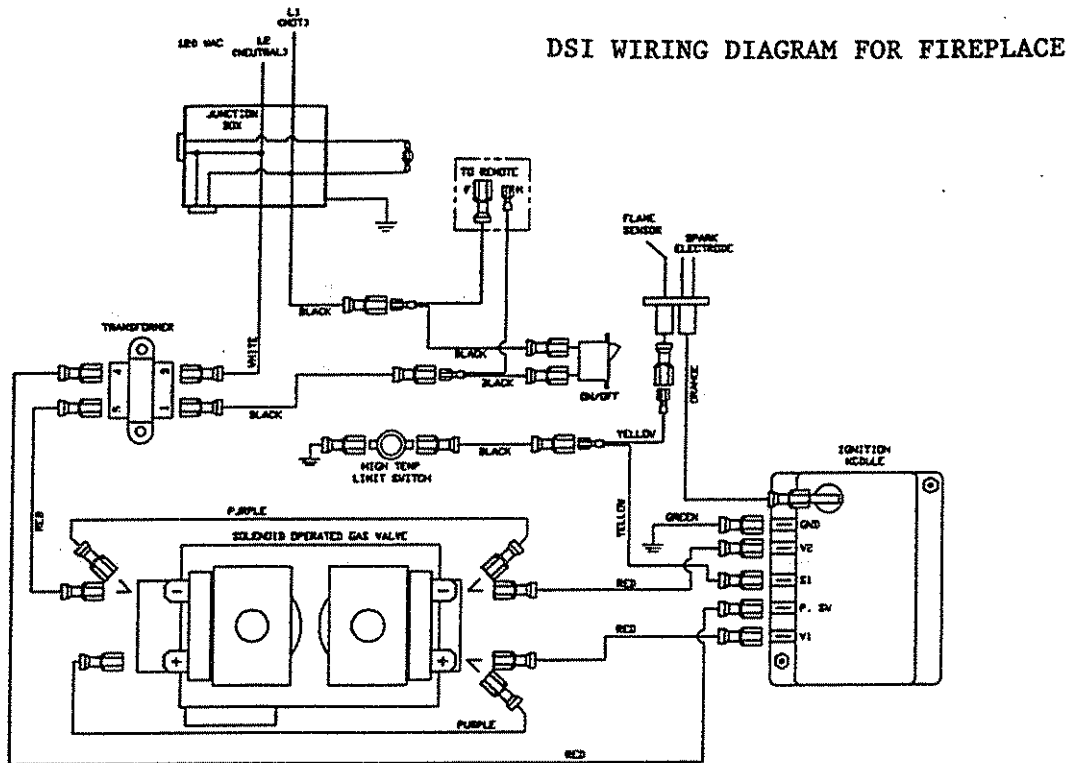

**LIMITED WARRANTY POLICY  
FOR HEAT-N-GLO FIREPLACE PRODUCTS, INC. GAS FIREPLACES**

The limited two year warranty will not become effective until the completed warranty card has been mailed to HEAT-N-GLO FIREPLACE PRODUCTS, INC., Savage, MN 55378.

This card must be mailed within 60 days of the fireplace installation.

Subject to the conditions set forth herein, HEAT-N-GLO FIREPLACE PRODUCTS, INC. extends the following warranty with respect to HEAT-N-GLO FIREPLACE PRODUCTS, INC. Decorative Gas Fireplaces.

If HEAT-N-GLO FIREPLACE PRODUCTS, INC. is satisfied that any part or portion of the fireplace covered by this limited warranty is defective in material or workmanship under normal use and service as described in the operating instructions, HEAT-N-GLO FIREPLACE PRODUCTS, INC. will take the following actions:

1. Within the first year from the date of installation, HEAT-N-GLO FIREPLACE PRODUCTS, INC. shall, at its option, replace or repair any such defect in material or workmanship, at HEAT-N-GLO FIREPLACE PRODUCTS, INC. expense. HEAT-N-GLO FIREPLACE PRODUCTS, INC. SHALL NOT BE RESPONSIBLE FOR ANY OTHER LABOR COSTS, OR EXPENSES, INCLUDING INDIRECT, INCIDENTAL, OR CONSEQUENTIAL DAMAGES.
2. During the second year after the date of installation, HEAT-N-GLO FIREPLACE PRODUCTS, INC. shall supply replacement parts at the current minimum wholesale price, but HEAT-N-GLO FIREPLACE PRODUCTS, INC. SHALL NOT BE RESPONSIBLE FOR ANY LABOR, TRANSPORTATION, OR OTHER INDIRECT, INCIDENTAL, OR CONSEQUENTIAL DAMAGES.
3. During the first six months after installation, HEAT-N-GLO FIREPLACE PRODUCTS, INC. shall, at its option, replace or repair the glass door if operation is faulty (this does not include glass panels broken during shipping, misuse, or careless handling). HEAT-N-GLO FIREPLACE PRODUCTS, INC. SHALL NOT BE RESPONSIBLE FOR ANY LABOR, TRANSPORTATION OR OTHER INDIRECT, INCIDENTAL, OR CONSEQUENTIAL DAMAGES. IF GLASS DOORS OTHER THAN FACTORY DOORS ARE USED, ALL WARRANTY AND LIABILITY ON THE FIREPLACE IS VOIDED.
4. All electrical, manual, and optional components or accessories found to be defective will be repaired or replaced without charge during the first year after installation.

HEAT-N-GLO FIREPLACE PRODUCTS, INC. may discharge its entire warranty liability by refunding the price of the product.

Products made by other manufacturers, sold with the fireplace or thereafter are not covered by this limited warranty. The use of other unauthorized components will make this warranty null and void.

This limited warranty will be void if the appliance is not installed by a qualified installer and according to the installation instructions. The limited warranty also is void if the fireplace is not operated, at all times, according to the operating instructions furnished.

EXCEPT TO THE EXTENT PROVIDED BY LAW, NO IMPLIED WARRANTIES OR MERCHANTABILITY OR FITNESS FOR A PARTICULAR PURPOSE, AND NO IMPLIED WARRANTIES SHALL APPLY TO THE FIREPLACE AFTER THE ABOVE LIMITED WARRANTY HAS EXPIRED.

In states that do not allow limitations on how long implied warranty lasts, or do not allow exclusion of indirect damages, those limitations or exclusions may not apply to you. You may also have additional rights not covered in this limited warranty.

HEAT-N-GLO FIREPLACE PRODUCTS, INC. reserves the right to make changes at anytime, without notice, in design, material, specifications, and prices and the right to discontinue styles and products.

