

NOTES:

- 1 NO COMBUSTIBLE MATERIAL WITHIN 6" OF THE TOP OF THE FIREPLACE. COMBUSTIBLE MATERIAL SHALL NOT BE PLACED DIRECTLY ON THE FACE OF THE FIREPLACE, TOP.
- 2 NO COMBUSTIBLE MATERIAL WITHIN 1" OF THE SIDES AND/OR BACK OF THE FIREPLACE. COMBUSTIBLE MATERIAL SHALL NOT BE PLACED DIRECTLY ON THE FACE OF THE FIREPLACE, BACK AND SIDES.
- 3 1" CLEARANCE TO B-VENT MUST BE MAINTAINED.
- 4 GAS PRESSURE LINE: 140,000 BTU MINIMUM AT 7.0"/11.0" W.C. REQUIRED. **NG/LP**
POWER REQUIREMENT: 120 VAC, 5 AMP MAX DRAW.
- 5 STEEL 3" SURFACE MAY BE LEFT EXPOSED OR COVERED WITH COMBUSTIBLE FINISHING MATERIAL. FASTENERS SHALL NOT PENETRATE THE 3" SURFACE.
- 6 COMBUSTIBLE MATERIAL SHALL NOT BE APPLIED TO THIS SURFACE SHOWN ABOVE THE 3" DIMENSION. NON-COMBUSTIBLE MATERIAL MAY BE APPLIED TO SURFACE SHOWN PRIOR TO FINISHING MATERIAL. IF FINISHING MATERIAL REQUIRES A STRUCTURAL BACKER.
- 7 STEEL 3" SURFACE MAY BE LEFT EXPOSED OR COVERED WITH NON-COMBUSTIBLE FINISHING MATERIAL. COMBUSTIBLE PROJECTIONS (MANTEL) SHALL BE 6" OR MORE ABOVE OPENING EDGE.
- 8 IF STRUCTURAL BACKER IS REQUIRED FOR FINISHING MATERIAL, COMBUSTIBLE MATERIAL IS ALLOWED IN THE AREA SHOWN BELOW THE 3" DIMENSION.
- 9 **DIMENSION SHOWN IS ALLOWABLE FINISHING DIMENSION. FINISHING MATERIAL SHALL NOT OVERLAP DIMENSION SHOWN.**
- 10 ACCESS PANELS WILL BE LOCATED IN APPROXIMATE AREAS SHOWN. GAS AND ELECTRICAL INLETS ARE LOCATED BEHIND THESE PANELS AND WILL BE USED FOR THE INITIAL INSTALL. THESE PANELS MAY BE USED FOR SERVICE AFTER INSTALLATION IF NOT COVERED. ACCESS PANELS ARE ALLOWED TO BE FINISHED OVER AS THERE IS ACCESS TO THE GAS AND ELECTRICAL COMPONENTS FROM INSIDE THE FIREPLACE IF SERVICE IS REQUIRED.
- 11 FIREPLACE OPTIONS:
FIREPLACE SHALL HAVE LINEAR FLAME DOWN THE LONG AXIS, RIBBON BURNER.
FIREPLACE SHALL HAVE MEDIA BED LIGHTING.
- 12 THE FIREPLACE WILL CONSUME CFM OF AIR AS NOTED IN TABLE.
FIREPLACE SHALL HAVE A SOUND REDUCTION CHAMBER.
- 13 FIREPLACE IS NOT LOAD BEARING. FINISHING MATERIAL SHALL BE SUPPORTED INDEPENDENTLY.
- 14 OPEN HEARTH:
COMBUSTIBLE FURNITURE, CURTAINS AND/OR DECORATIONS ETC. MUST BE A MINIMUM DISTANCE SHOWN FROM OPEN FACE OF FIREPLACE.
- 15 FIREPLACE WILL BE DESIGNED TO ACCEPT 2" THICK MAXIMUM FIELD INSTALLED FIREPLACE APPROVED, NON-COMBUSTIBLE MATERIAL, PROVIDED BY OTHERS.

HEIGHT OPTIONS PER MODEL							
MODEL NUMBER	DIM "A"	DIM "B"	DIM "C"	DIM "D"	DIM "F"	DIM "G"	CFM
8-ST-18-LOH	18"	36"	50"	64 7/8"	Ø 16"	30 1/16"	1440
FIREPLACE APPROVED, NON-COMBUSTIBLE MATERIAL OPTION							
INTERIOR				DIM "E"			
LINER	SHEET 2		92"				
NO LINER	SHEET 2		96"				

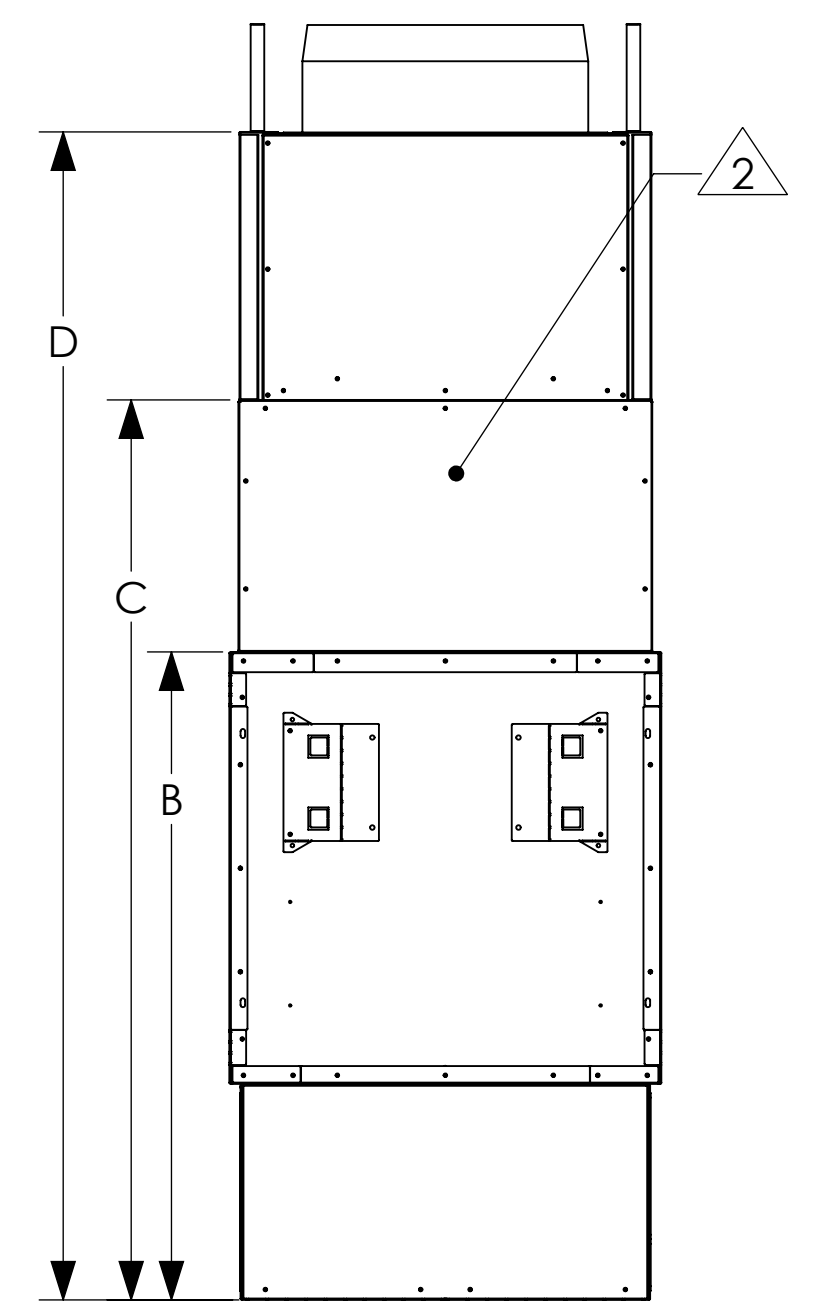
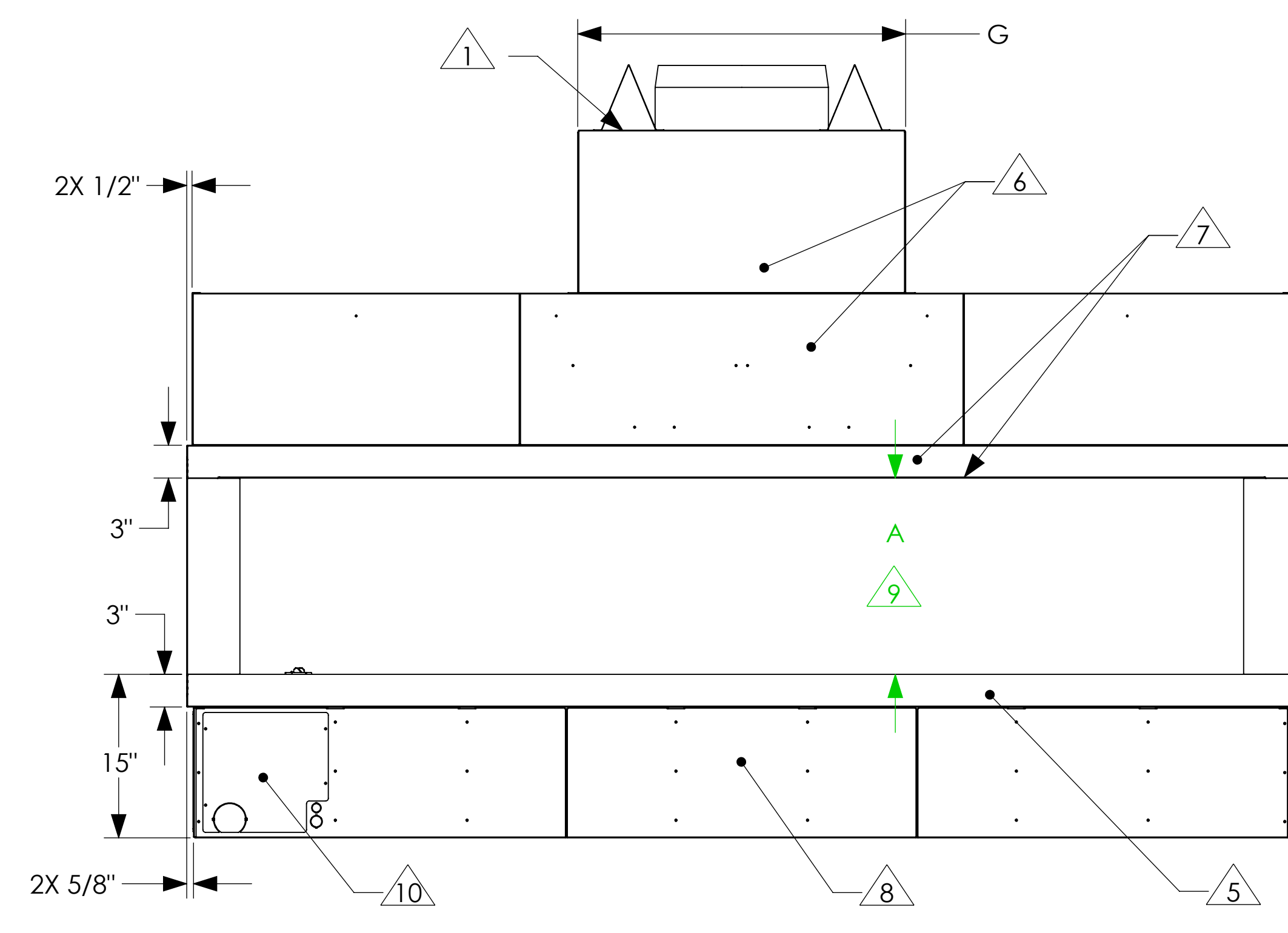
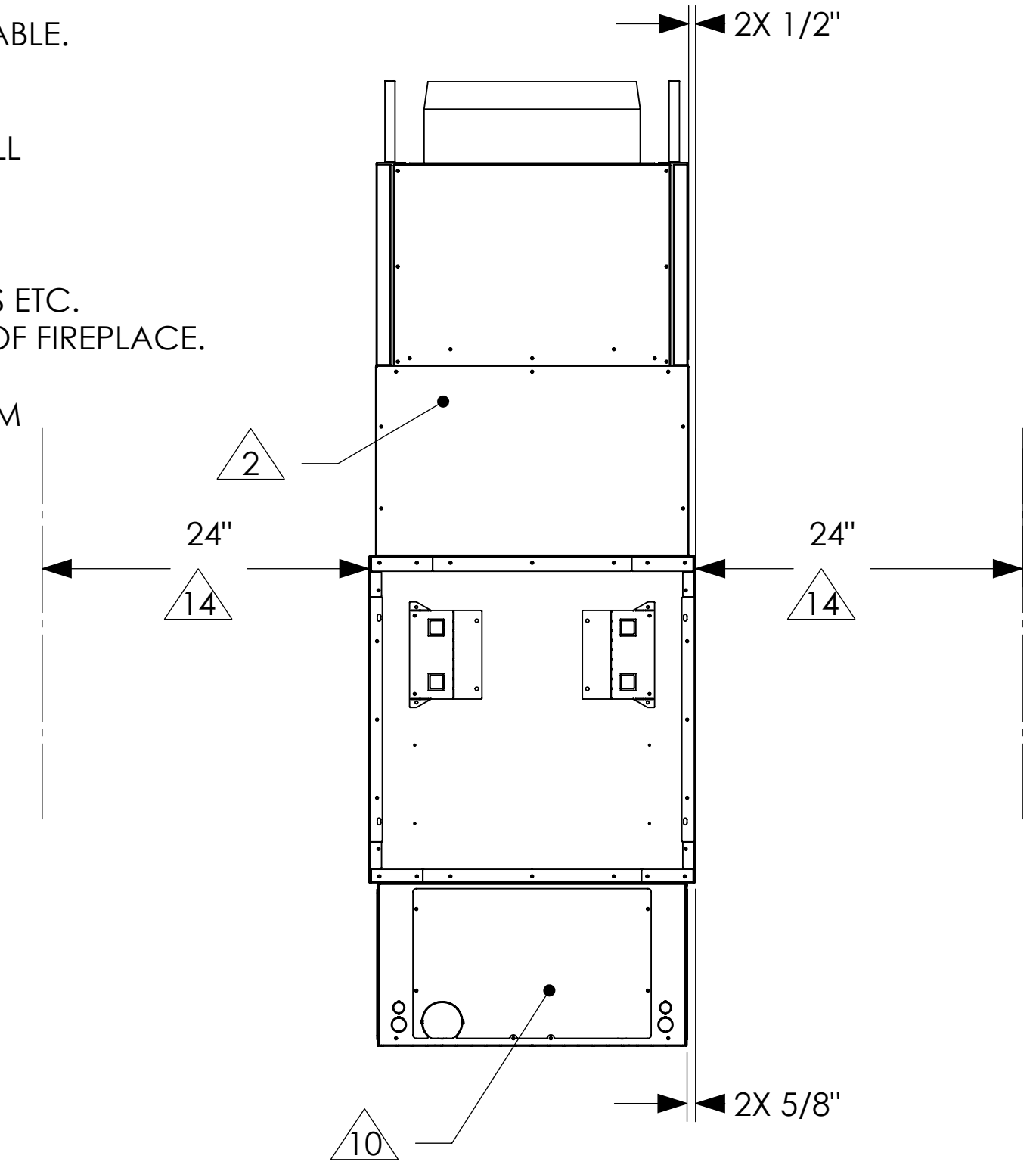
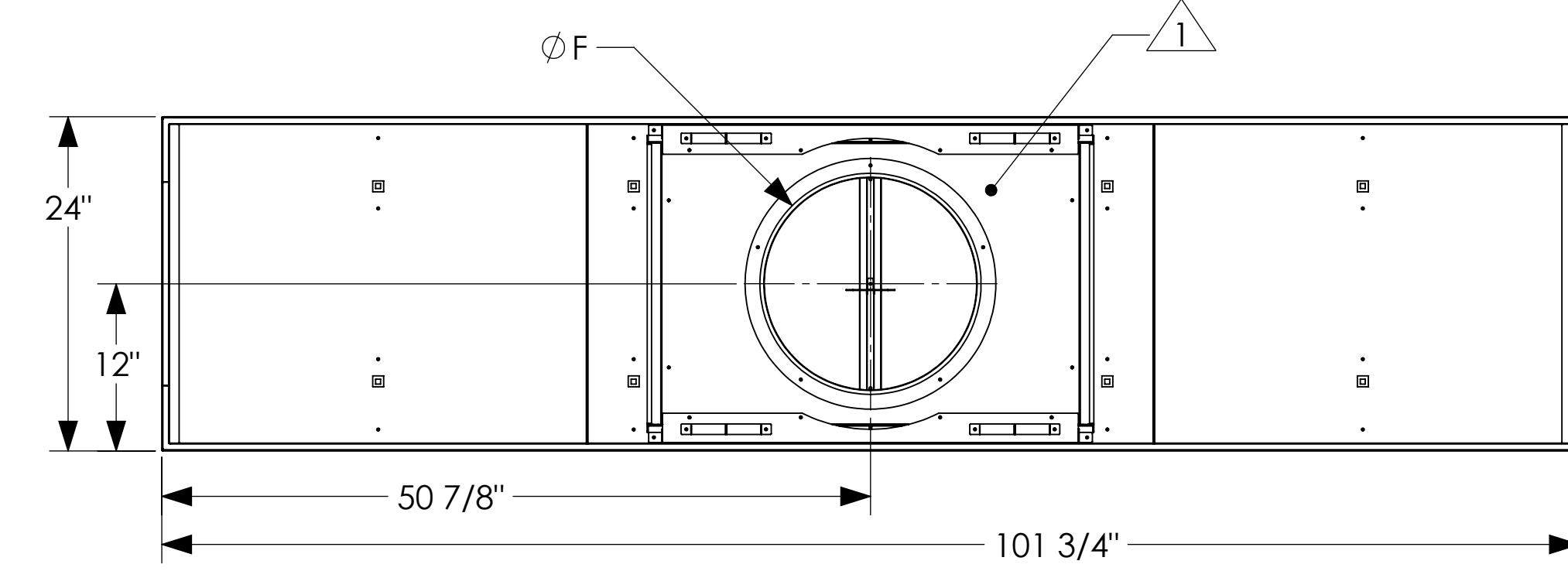
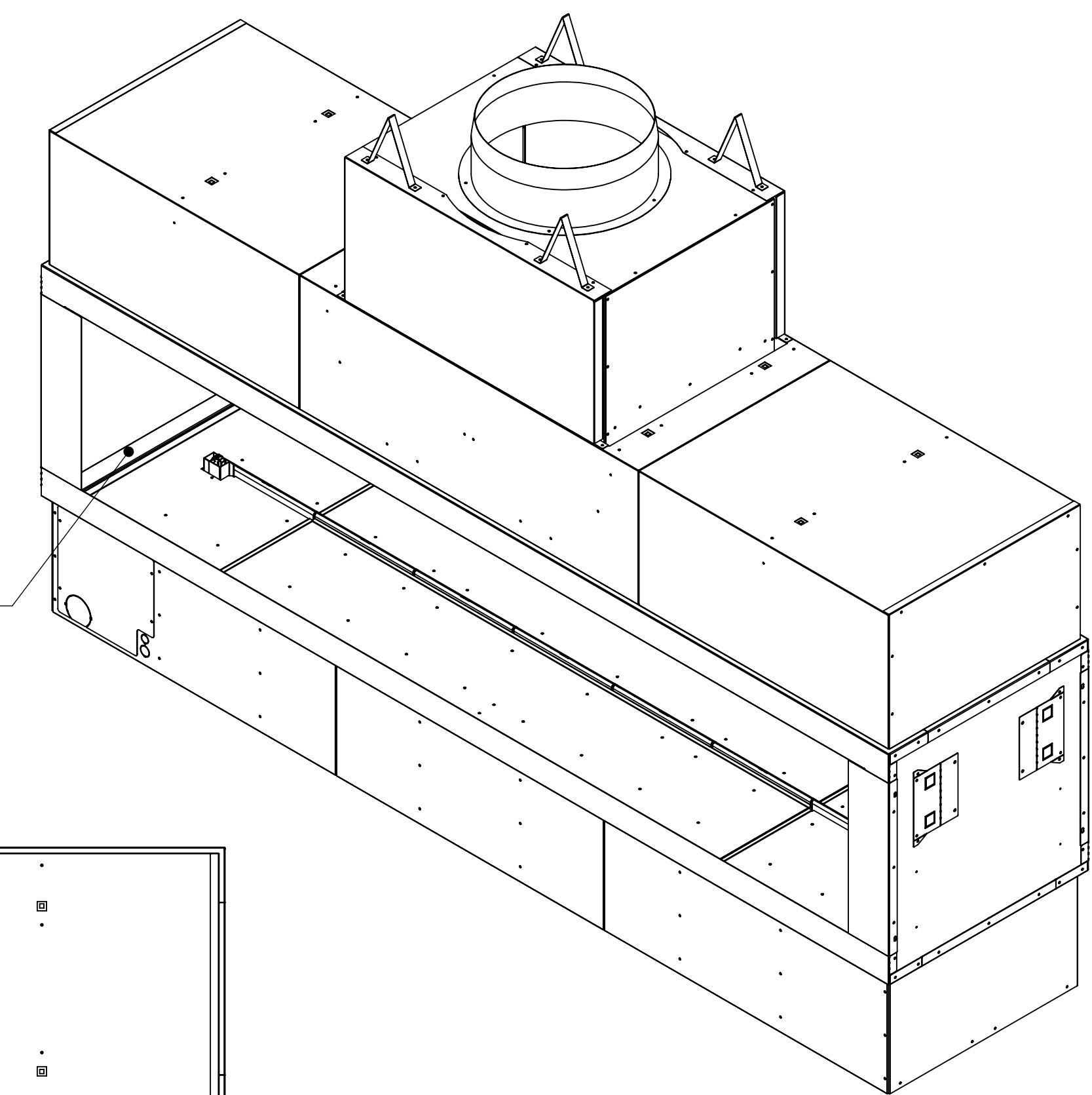

UNLESS OTHERWISE SPECIFIED DIMENSIONS ARE IN INCHES: TOLERANCE - (1) PLACE DEC: ±0.1 (2) PLACE DEC: ±0.06 (3) PLACE DEC: ±0.031 ANGLE: ±2° FRACTION ±1/16
 ◀ OUTSIDE MATERIAL. ○ EDGE OR INSIDE MATERIAL. ◄ OUTSIDE APEX. ● INSIDE APEX. - DIMS ENCLOSED BY AN OVAL ARE CRITICAL DIMENSIONS

REV	REVISIONS	DATE	DRFT	ENG
A	RELEASE TO PRODUCTION	6-26-24	DW	RB
1	PRELIMINARY RELEASE	6-13-23	DW	RB



MODEL DESCRIPTION: 8' SEE THRU		DATE: 6-13-23	SERIES NAME: OPEN HEARTH
DRAWN BY: R. BERG	ENGINEER: R. BERG	SCALE: N/A	SHEET: SHEET 1 OF 3
DRAWING NUMBER: 8-ST-LOH-SERIES		REV: A	

WITHOUT LINER

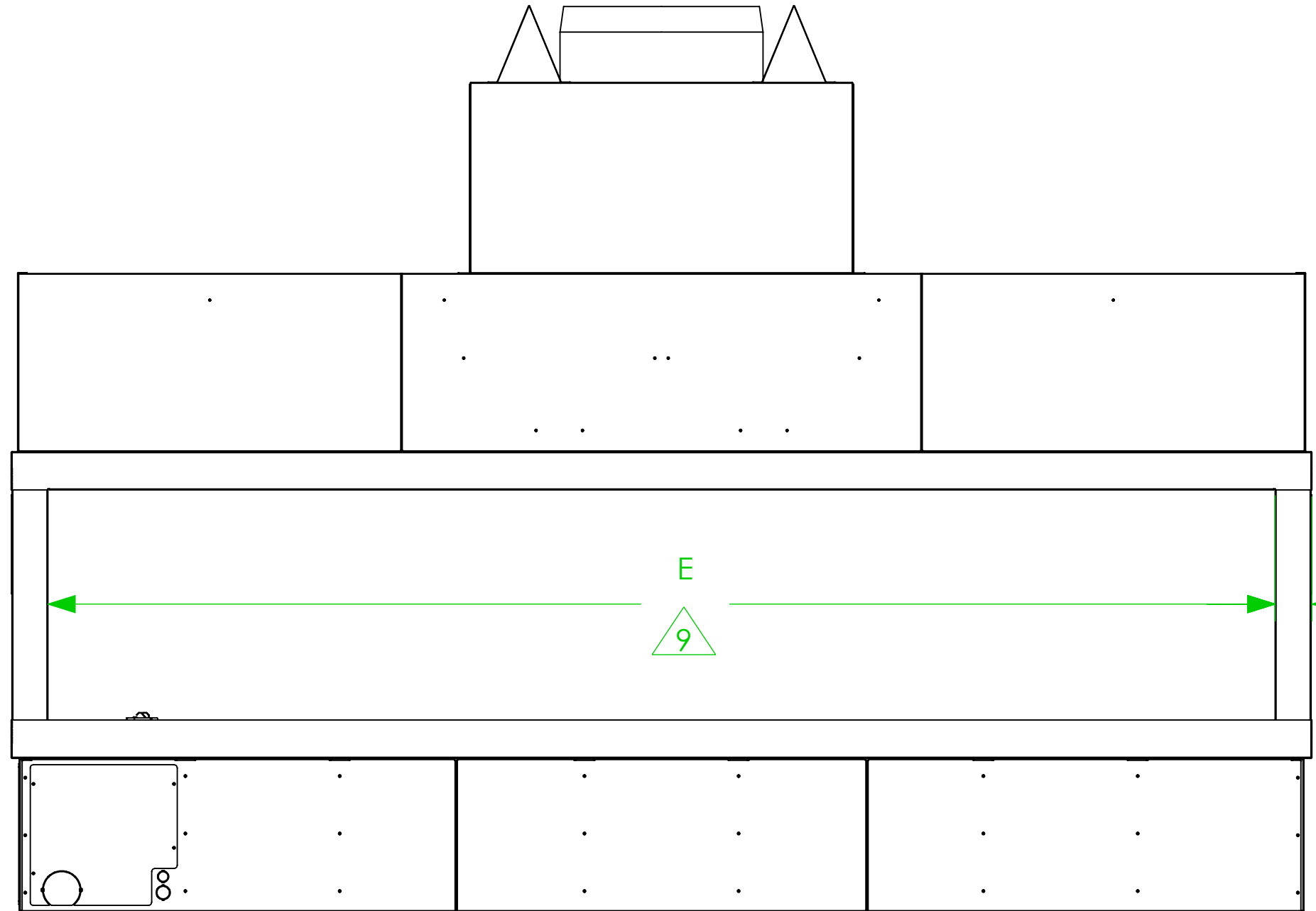
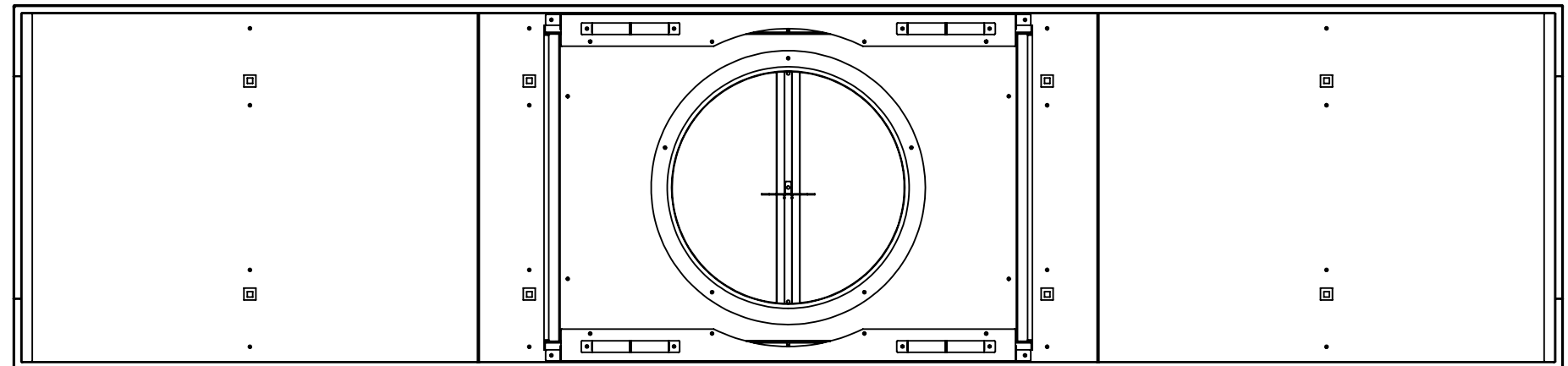

2 7/8" RECESSED

LINER

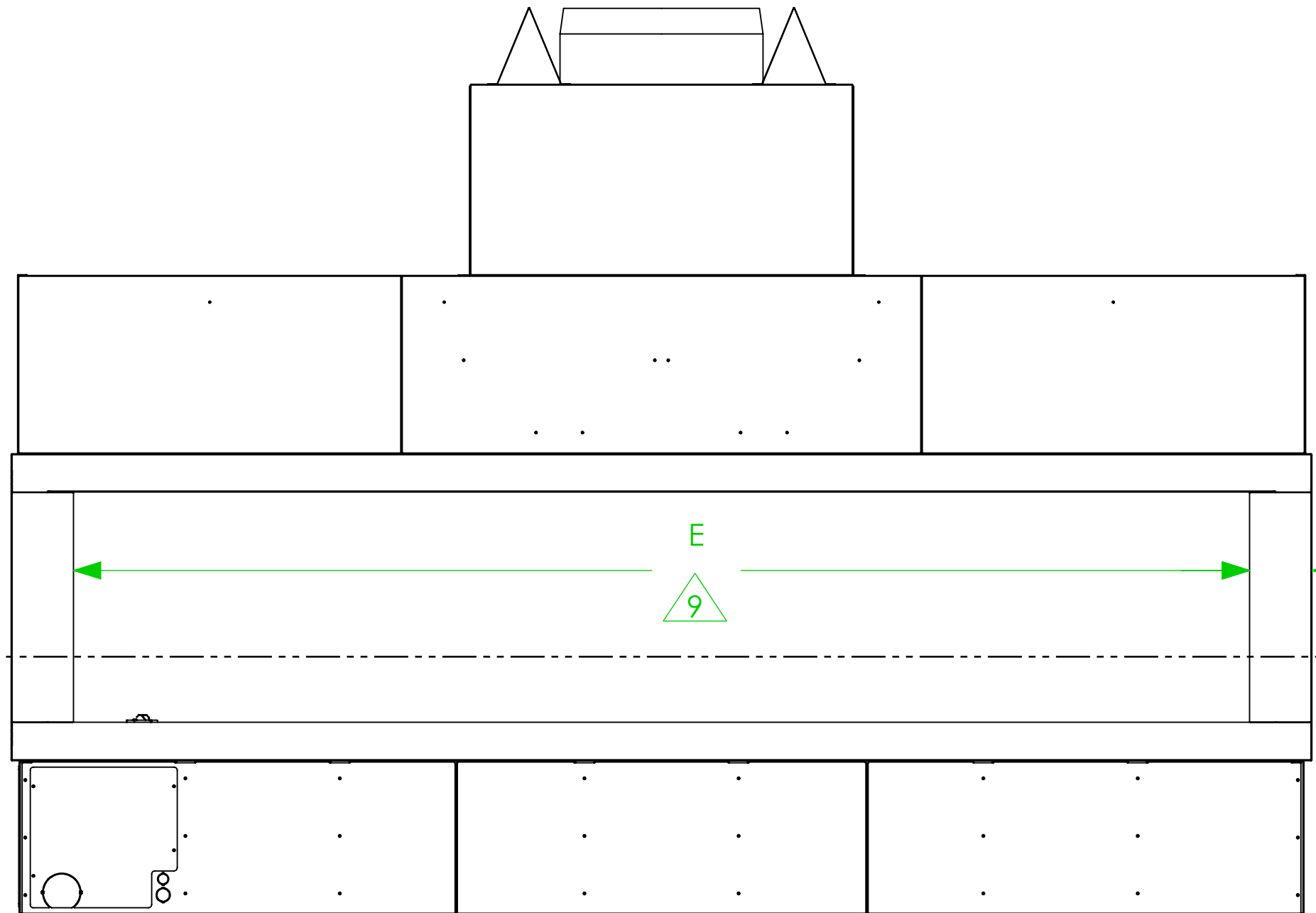
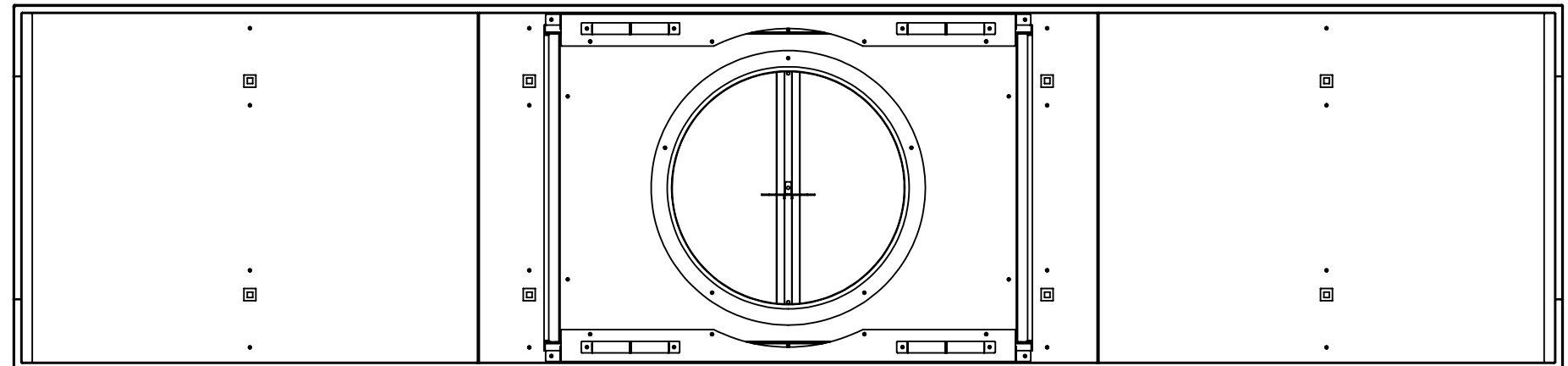

4 7/8" RECESSED

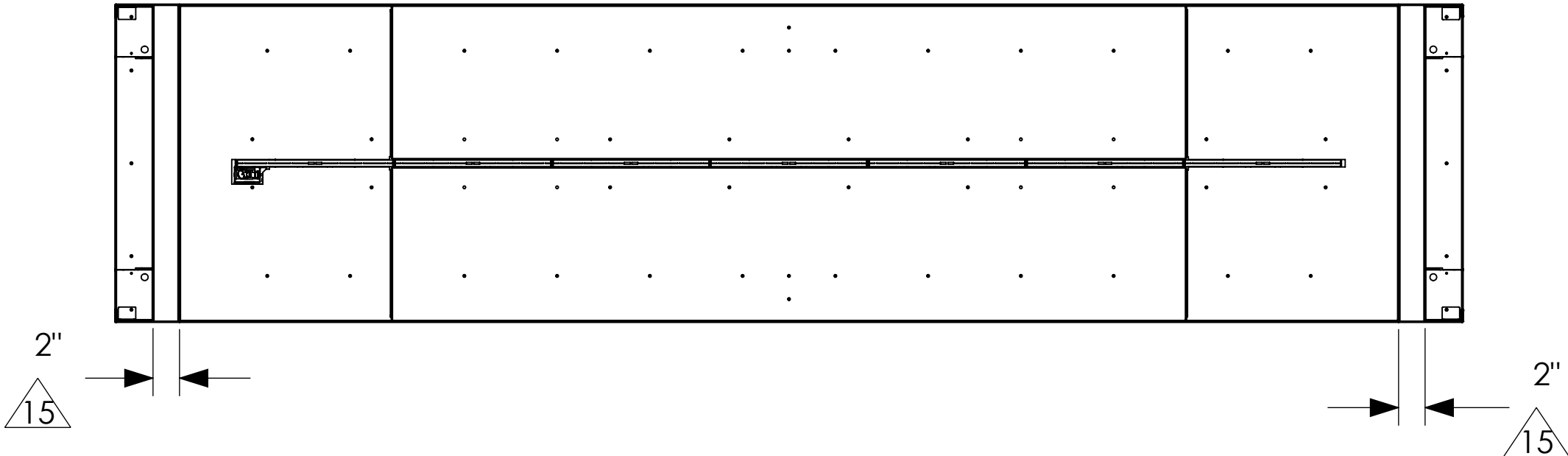

SECTION A-A

UNLESS OTHERWISE SPECIFIED DIMENSIONS ARE IN INCHES: TOLERANCE - (1) PLACE DEC: ±0.1 (2) PLACE DEC: ±0.06 (3) PLACE DEC: ±0.031 ANGLE: ±2° FRACTION ±1/16

	MODEL DESCRIPTION: 8' SEE THRU			
	DRAWN BY:	DATE: 6-13-23	SERIES NAME: OPEN HEARTH	DRAWING NUMBER: 8-ST-LOH-SERIES
ENGINEER: R. BERG	SCALE: N/A	SHEET: SHEET 2 OF 3	REV: A	

DRAWING AND DESIGN IS PROPERTY OF HEARTH & HOME TECHNOLOGIES

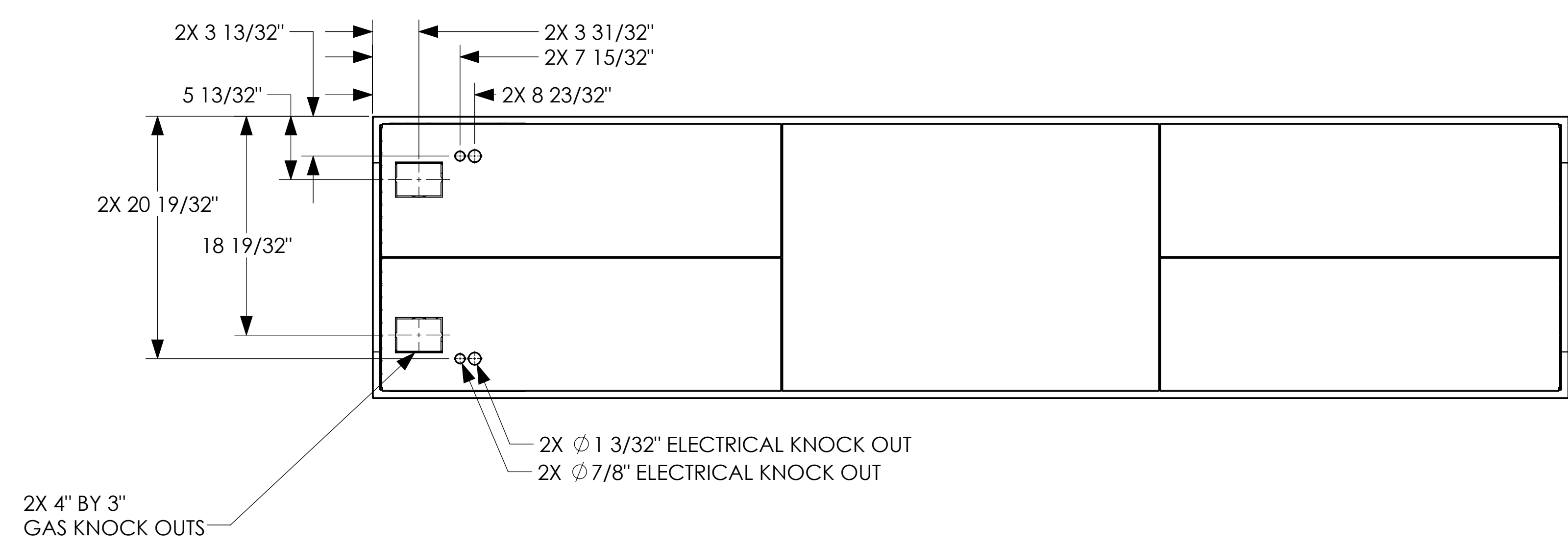
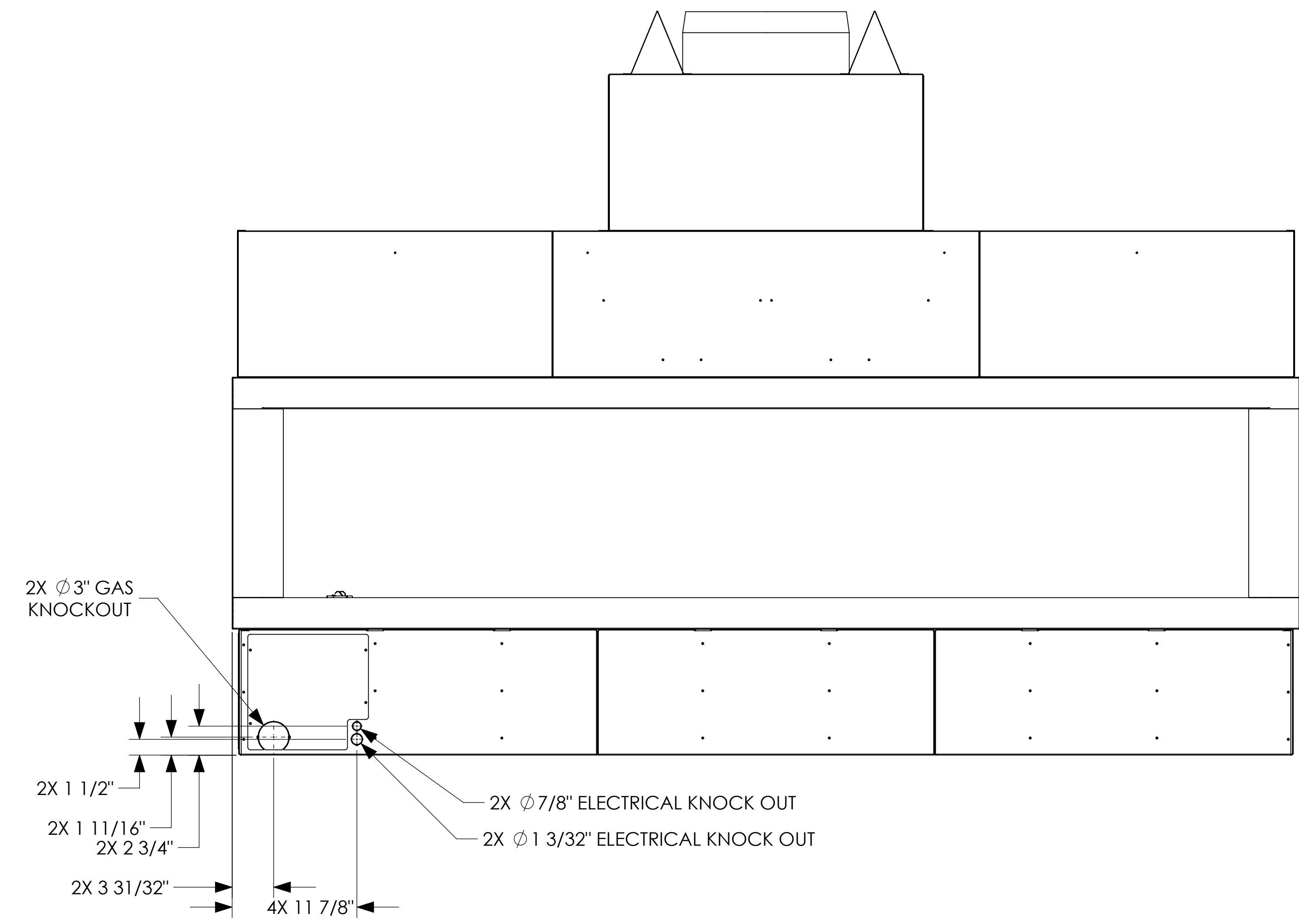
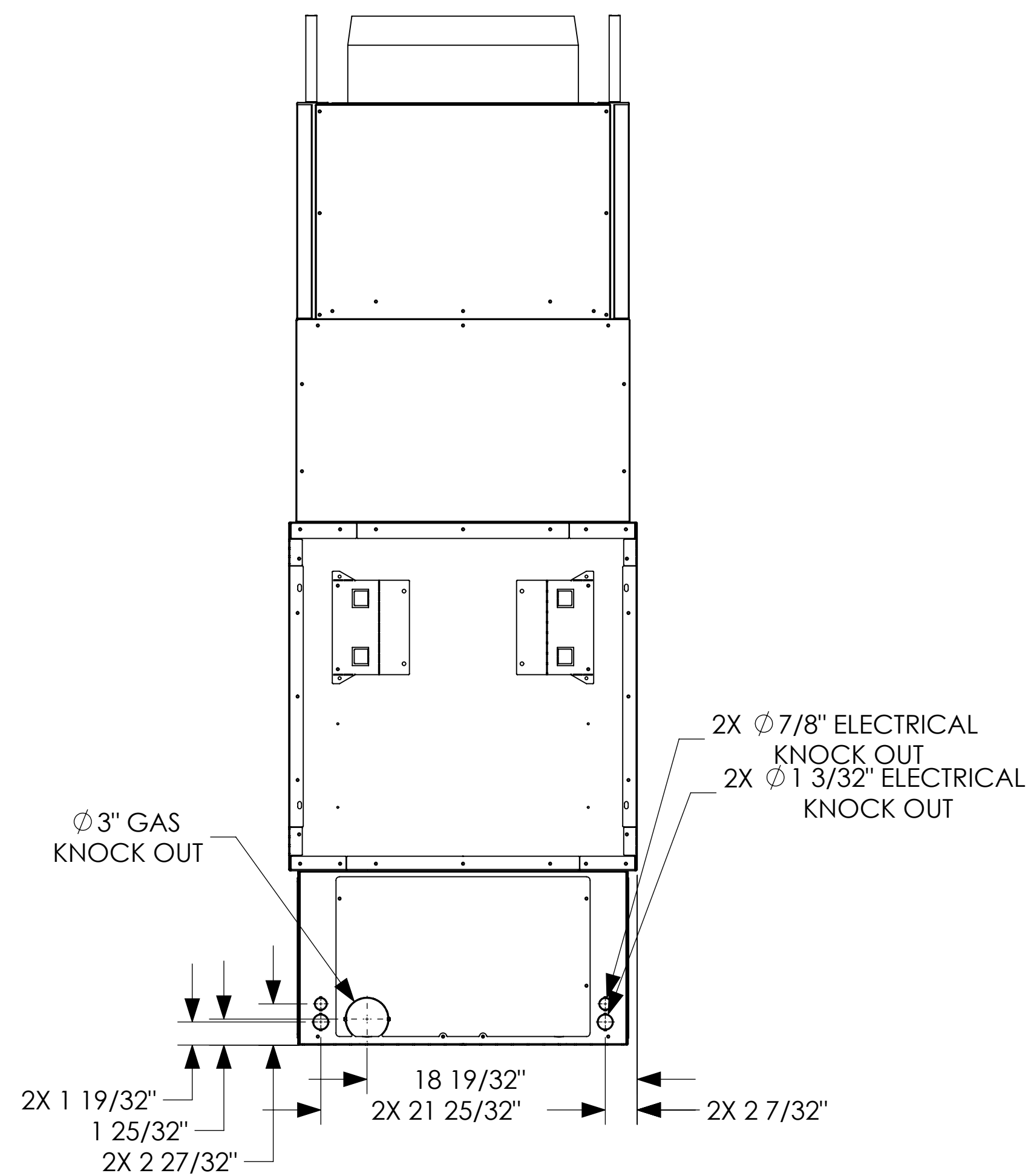

UNLESS OTHERWISE SPECIFIED DIMENSIONS ARE IN INCHES: TOLERANCE - (1) PLACE DEC: ± 0.1 (2) PLACE DEC: ± 0.06 (3) PLACE DEC: ± 0.031 ANGLE: $\pm 2^\circ$ FRACTION $\pm 1/16$
 ◀ OUTSIDE MATERIAL. ◯ EDGE OR INSIDE MATERIAL. ◯ OUTSIDE APEX. • INSIDE APEX. - DIMS ENCLOSED BY AN OVAL ARE CRITICAL DIMENSIONS



DRAWING AND DESIGN IS PROPERTY OF HEARTH & HOME TECHNOLOGIES

MODEL DESCRIPTION: 8' SEE THRU		DATE: 6-13-23	SERIES NAME: OPEN HEARTH	DRAWING NUMBER: 8-ST-LOH-SERIES	REV: A
DRAWN BY:	ENGINEER: R. BERG	SCALE: N/A	SHEET: SHEET 3 OF 3		