

NOTES: ( FLAG NOTES ARE ON SHEET 2 UNLESS OTHERWISE SPECIFIED )

- 1 NO COMBUSTIBLE MATERIAL WITHIN 6" OF THE TOP OF THE FIREPLACE.  
COMBUSTIBLE MATERIAL SHALL NOT BE PLACED DIRECTLY ON THE FACE OF THE FIREPLACE, TOP.
- 2 NO COMBUSTIBLE MATERIAL WITHIN 1" OF THE SIDES AND BACK OF THE FIREPLACE.  
COMBUSTIBLE MATERIAL SHALL NOT BE PLACED DIRECTLY ON THE FACE OF THE FIREPLACE, BACK AND SIDES.
- 3 1" CLEARANCE TO B-VENT MUST BE MAINTAINED.
- 4 GAS LINE PRESSURE: 100,000 BTU MEASURED AT 7.0"/11.0" W.C. REQUIRED. **NG/LP**  
POWER REQUIREMENT: 120 VAC, 5 AMP MAX DRAW.
- 5 STEEL 3" SURFACE CAN NOT BE COVERED WITH ANY TYPE OF MATERIAL,  
GLASS AND DECORATIVE FRAME WILL BE PLACES ON TO OF THIS SURFACE.  
FASTEMERS SHALL NOT PENETRATE THE 3" SURFACE.
- 6 COMBUSTIBLE MATERIAL SHALL NOT BE APPLIED TO THIS SURFACE SHOWN ABOVE THE 3" DIMENSION.  
NON-COMBUSTIBLE MATERIAL MAY BE APPLIED TO SURFACE SHOWN PRIOR TO FINISHING MATERIAL.  
IF FINISHING MATERIAL REQUIRES A STRUCTUAL BACKER.
- 7 THE 1/2" CLEARANCE TO COMBUSTIBLES MUST BE MAINTAINED ON THIS SURFACE.  
IF THE 1/2" STAND OFFS ARE REMOVED, ONLY NON-COMBUSTIBLE MATERIAL SHALL BE INTALLED AGAINST THIS SURFACE.  
1/2" INCH STAND OFFS ARE INCLUDED ON FACE OF FIREPLACE.
- 8 IF STRUCTURAL BACKER IS REQUIRED FOR FINISHING MATERIAL,  
COMBUSTIBLE MATERIAL IS ALLOWED IN THE AREA SHOWN BELOW THE 3" DIMENSION.
- 9 ( SHEET 1 )  
DIMENSION SHOWN IS ALLOWABLE FINISHING DIMENSION. THIS IS THE OPENING SIZE REQUIRED  
TO FIT THE DECOATIVE FRAME ONTO THE FIREPLACE. FINISHING MATERIAL SHALL NOT OVERLAP DIMENSION SHOWN.
- 10 FLAT COVERS WILL COVER THE COMPONENT ACCESS AREA.  
GAS AND ELECTRICAL INLETS ARE LOCATED BEHIND THESE PANELS.  
THESE ARE USED FOR MANUFACTURING PURPOSES AND MAY BE USED  
AFTER FIREPLACE INSTALLATION TO ACCESS COMPONENTS DURING SERVICE.  
THERE SHALL BE ACCESS FROM THE INSIDE OF THE FIREPLACE AS WELL.
- 11 GLASS SHALL NOT BE DIVIDED INTO SECTIONS. GLASS SHALL BE SAFE T TOUCH SYSTEM THAT  
COMPLIES WITH ANSI STANDARD Z 21.50, MAX TEMPERATURE 172 °F.
- 12 FIREPLACE OPTIONS:  
FIREPLACE SHALL HAVE LINEAR FLAME DOWN THE LONG AXIS, RIBBON BURNER.  
FIREPLACE SHALL HAVE MEDIA BED LIGHTING.
- 13 FIREPLACE SHALL BE MADE USING STAINLESS STEEL MATERIAL.
- 14 FLASHING SHALL BE ON THE TOP, AND SIDES.  
FLASHING IS REQUIRED UNDER AIR INTAKE AND  
SHALL BE PROVIDED BY OTHERS, FLASHING MAY  
CHANGE PER FINISHING MATERIAL
- 15 ( SHEET 1 )  
OUTSIDE AIR INTAKE LOCATION.  
AIR INTAKE SHALL RUN THE LENGTH OF THE FIREPLACE.

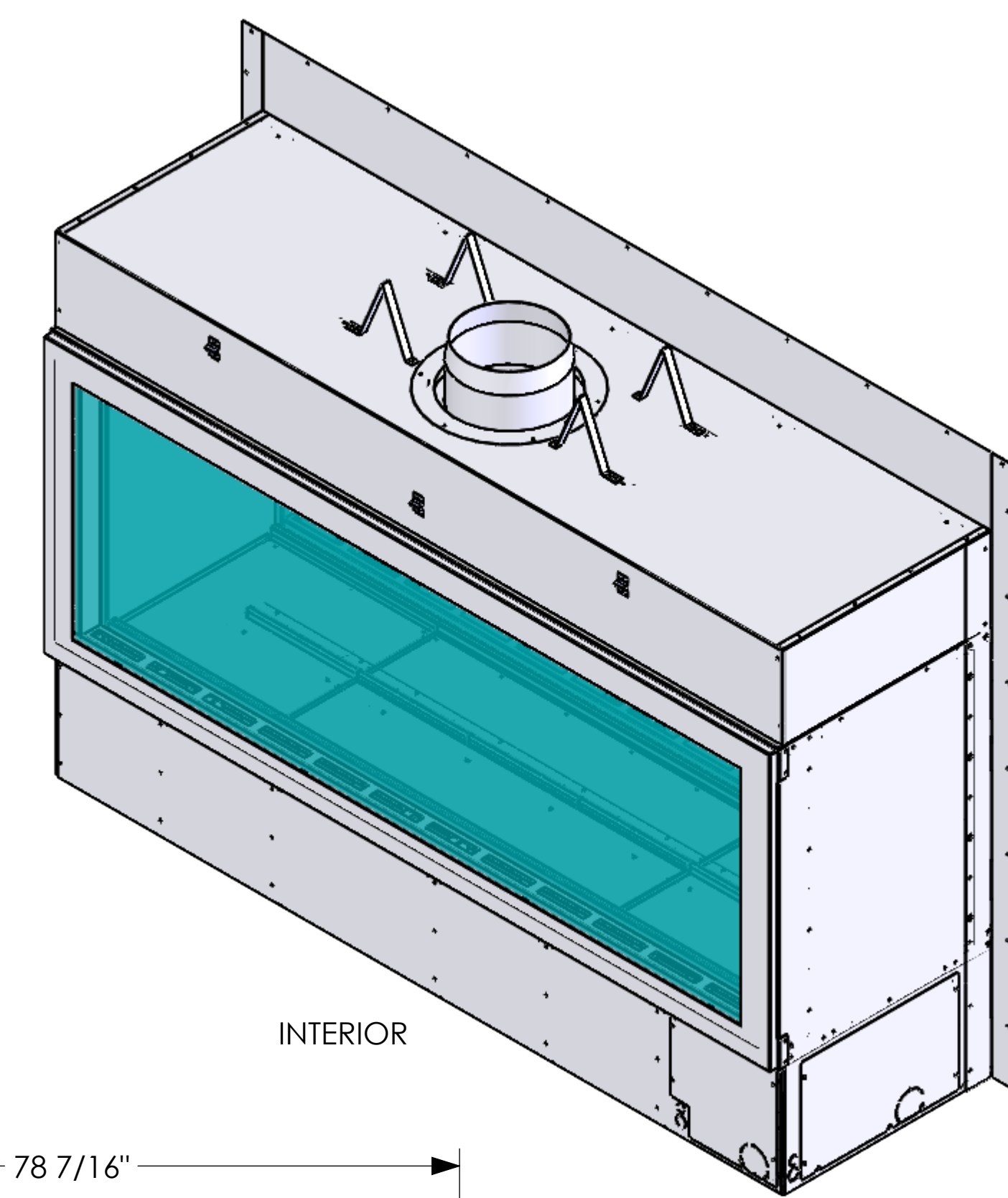

INTERIOR

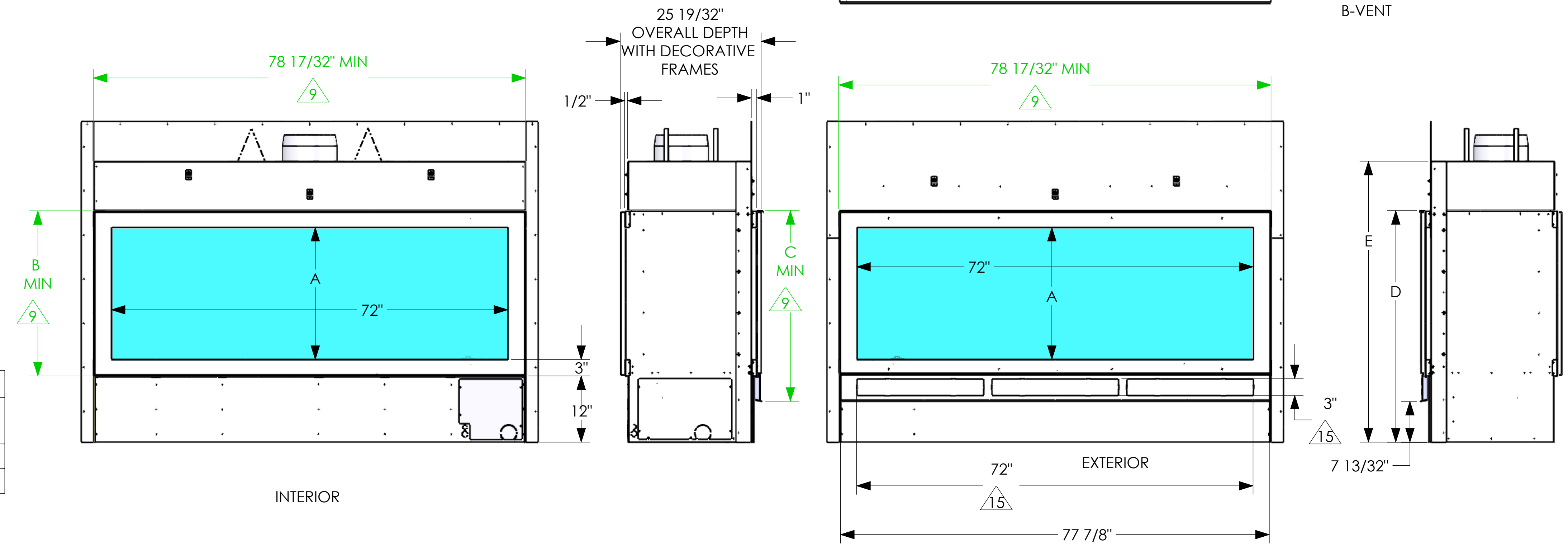
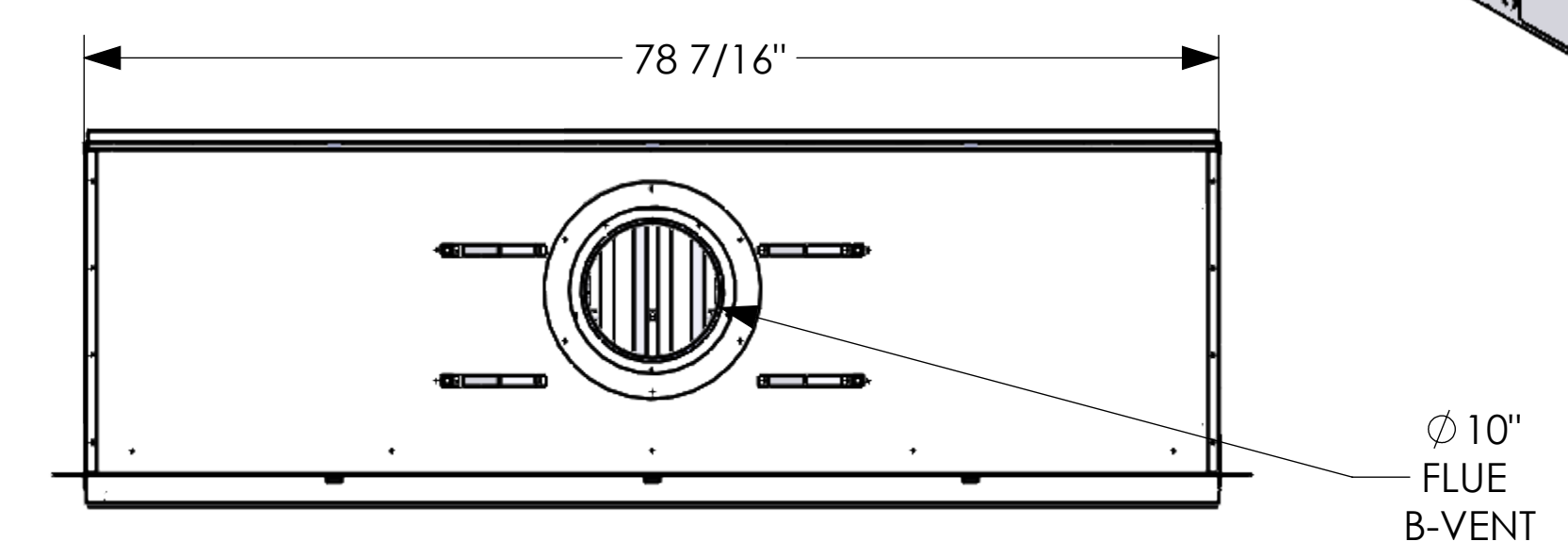

HEIGHT OPTIONS PER MODEL						
MODEL NUMBER	DIM "A"	DIM "B"	DIM "C"	DIM "D"	DIM "E"	DIM "F"
6-IDOD-24-G	24"	30"	34 5/8"	42 1/32"	51"	58 7/32"
6-IDOD-36-G	36"	42"	46 5/8"	54 1/32"	63"	70 7/32"

REV	REVISIONS	DATE	DRFT	ENG
4	CHANGED MODEL#, ADDED PAGE 3	9-14-23	SS	RB
3	CHANGED DIMENSION "C", ADDED ANGLED DIMENSION	8-24-22	ML	RB
2	CHANGED PROJECT NAME	4-12-22	ML	RB
1	PRELIMINARY RELEASE	3-29-22	ML	RB

UNLESS OTHERWISE SPECIFIED DIMENSIONS ARE IN INCHES: TOLERANCE - (1) PLACE DEC: ±0.1 (2) PLACE DEC: ±0.06 (3) PLACE DEC: ±0.031 ANGLE: ±2° FRACTION ±1/16  
 ← OUTSIDE MATERIAL. ○ EDGE OR INSIDE MATERIAL. ◐ OUTSIDE APEX. ● INSIDE APEX. - DIMS ENCLOSED BY AN OVAL ARE CRITICAL DIMENSIONS

**STELLAR**  
by Heat & Glo

MODEL DESCRIPTION: 6' INDOOR/ OUTDOOR

DRAWN BY: M.LEET	DATE: 3-29-22	SERIES NAME: TRANSCEND
ENGINEER: R.BERG	SCALE: N/A	STYLE: SHEET 1 OF 1

DRAWING AND DESIGN IS PROPERTY OF HEARTH & HOME TECHNOLOGIES

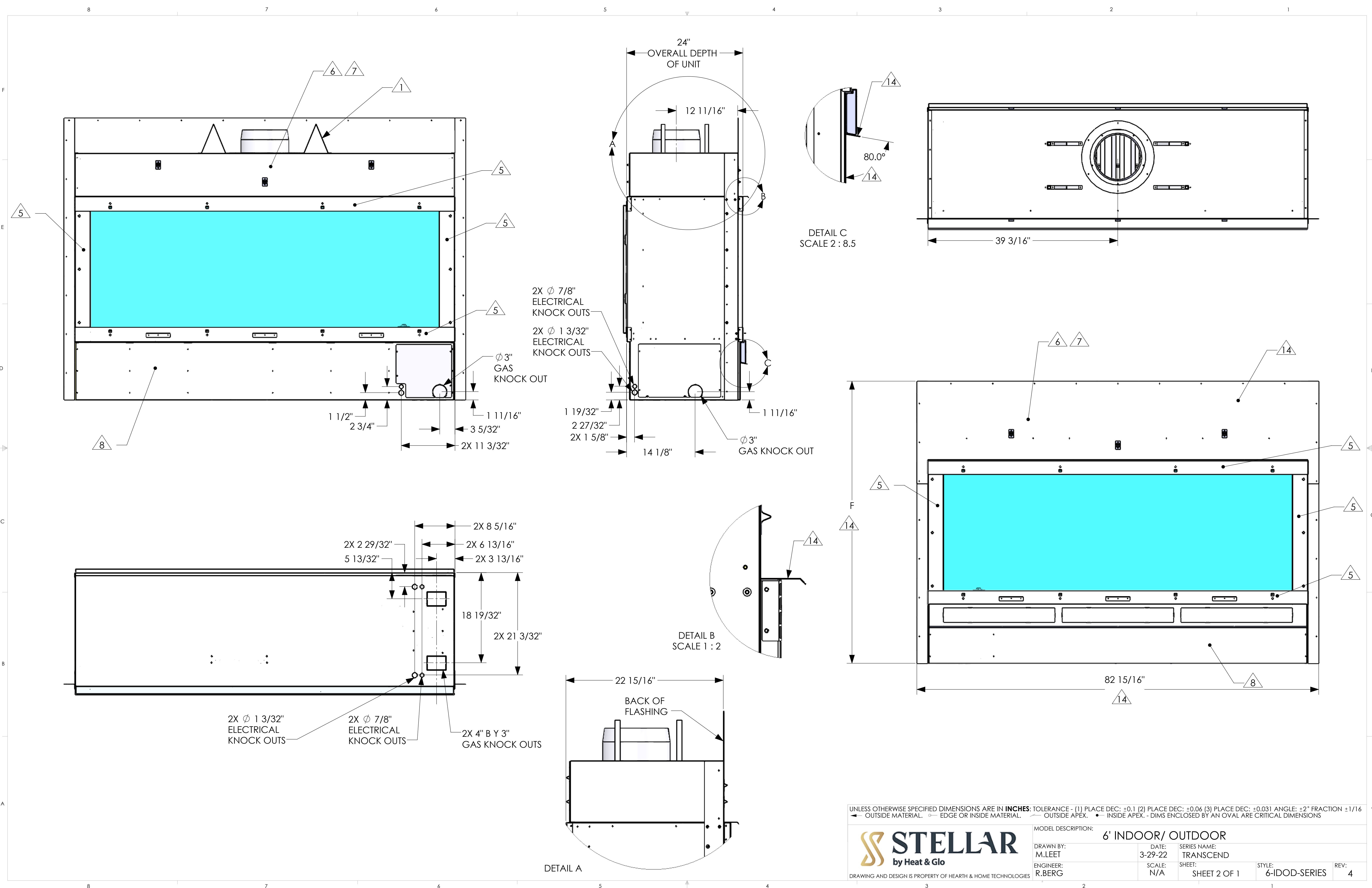

UNLESS OTHERWISE SPECIFIED DIMENSIONS ARE IN INCHES: TOLERANCE - (1) PLACE DEC:  $\pm 0.1$  (2) PLACE DEC:  $\pm 0.06$  (3) PLACE DEC:  $\pm 0.031$  ANGLE:  $\pm 2^\circ$  FRACTION  $\pm 1/16$

	MODEL DESCRIPTION: 6' INDOOR/ OUTDOOR			
	DRAWN BY: M.LEET	DATE: 3-29-22	SERIES NAME: TRANSCEND	
	ENGINEER: R.BERG	SCALE: N/A	SHEET: SHEET 2 OF 1	STYLE: 6-IDOD-SERIES
	DRAWING AND DESIGN IS PROPERTY OF HEARTH & HOME TECHNOLOGIES		REV: 4	

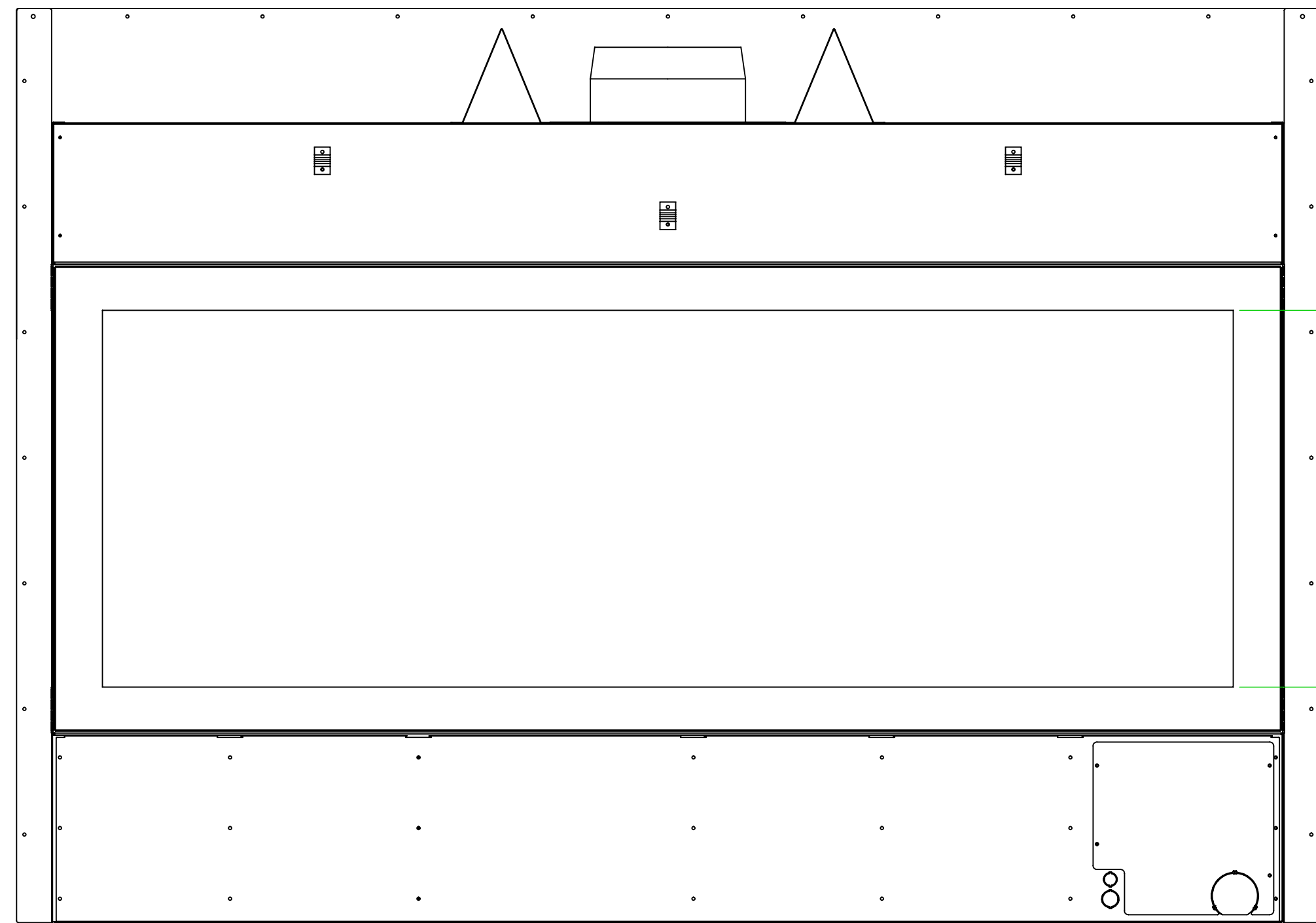

6-IDOD-24-G

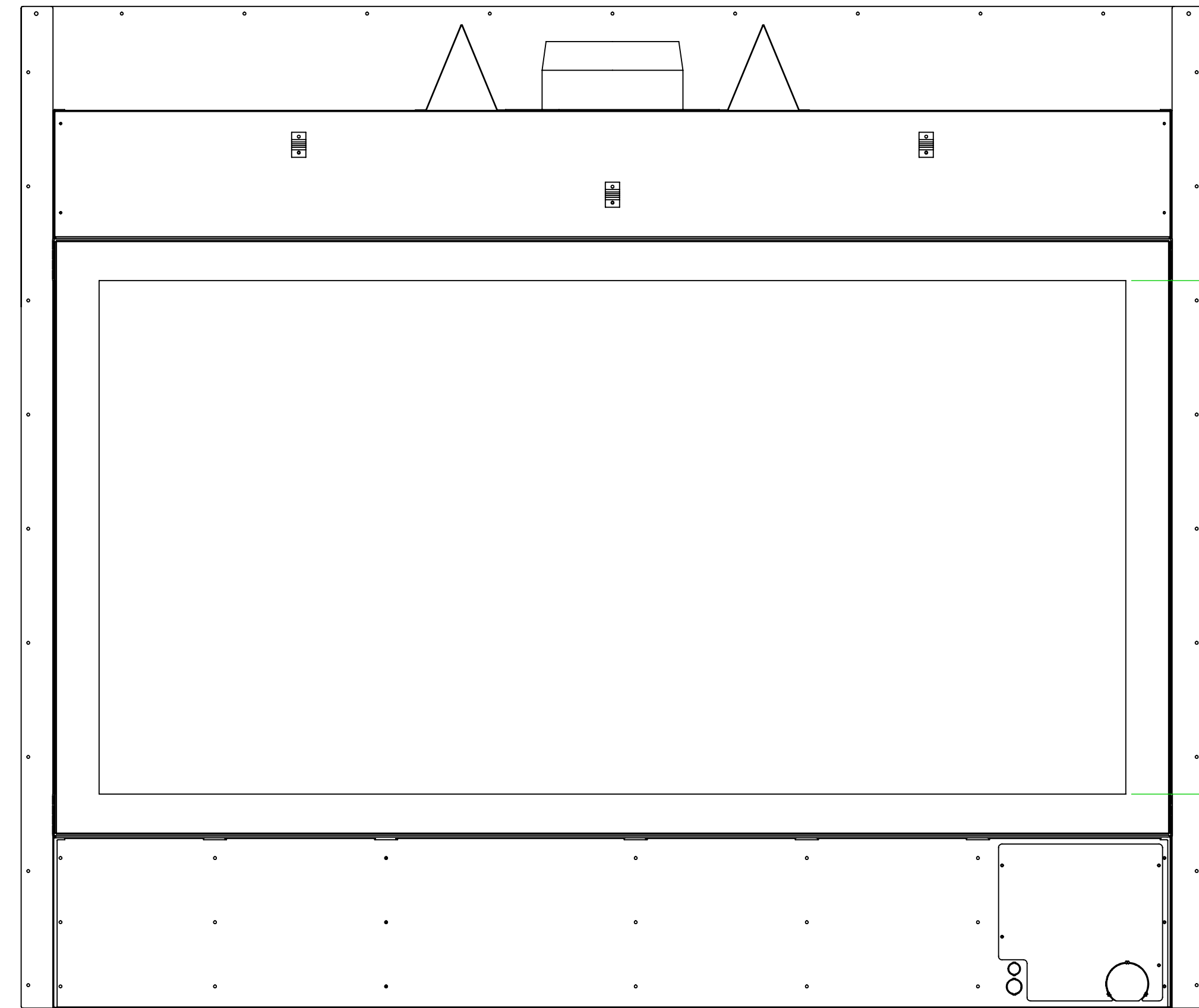

6-IDOD-36-G

UNLESS OTHERWISE SPECIFIED DIMENSIONS ARE IN **INCHES**: TOLERANCE - (1) PLACE DEC:  $\pm 0.1$  (2) PLACE DEC:  $\pm 0.06$  (3) PLACE DEC:  $\pm 0.031$  ANGLE:  $\pm 2^\circ$  FRACTION  $\pm 1/16$   
 ◄ OUTSIDE MATERIAL. ◉ EDGE OR INSIDE MATERIAL. ◄ OUTSIDE APEX. • INSIDE APEX. - DIMS ENCLOSED BY AN OVAL ARE CRITICAL DIMENSIONS



DRAWING AND DESIGN IS PROPERTY OF HEARTH & HOME TECHNOLOGIES

PART NAME: <b>72 X 24 SEE THRU</b>		DATE: 2-19-20		MATERIAL:	
DRAWN BY: M.LEET		SCALE: N/A		SHEET: SHEET 3 OF 1	
ENGINEER: R.BERG		PART NUMBER: 6-IDOD-SERIES		REV: 3	