

NOTES: ( FLAG NOTES ARE ON SHEET 2 UNLESS OTHERWISE SPECIFIED )

- 1 NO COMBUSTIBLE MATERIAL WITHIN 6" OF THE TOP OF THE FIREPLACE. COMBUSTIBLE MATERIAL SHALL NOT BE PLACED DIRECTLY ON THE FACE OF THE FIREPLACE, TOP.
- 2 NO COMBUSTIBLE MATERIAL WITHIN 1" OF THE SIDES AND BACK OF THE FIREPLACE. COMBUSTIBLE MATERIAL SHALL NOT BE PLACED DIRECTLY ON THE FACE OF THE FIREPLACE, BACK AND SIDES.
- 3 1" CLEARANCE TO B-VENT MUST BE MAINTAINED.
- 4 GAS LINE PRESSURE: 60,000 BTU MEASURED AT 7.0"/11.0" W.C. REQUIRED. **NG/LP**  
POWER REQUIREMENT: 120 VAC, 5 AMP MAX DRAW.
- 5 STEEL 3" SURFACE CAN NOT BE COVERED WITH ANY TYPE OF MATERIAL, GLASS AND DECORATIVE FRAME WILL BE PLACES ON TO OF THIS SURFACE. FASTEMERS SHALL NOT PENETRATE THE 3" SURFACE.
- 6 COMBUSTIBLE MATERIAL SHALL NOT BE APPLIED TO THIS SURFACE SHOWN ABOVE THE 3" DIMENSION. NON-COMBUSTIBLE MATERIAL MAY BE APPLIED TO SURFACE SHOWN PRIOR TO FINISHING MATERIAL. IF FINISHING MATERIAL REQUIRES A STRUCTUAL BACKER.
- 7 THE 1/2" CLEARANCE TO COMBUSTIBLES MUST BE MAINTAINED ON THIS SURFACE. IF THE 1/2" STAND OFFS ARE REMOVED, ONLY NON-COMBUSTIBLE MATERIAL SHALL BE INTALLED AGAINST THIS SURFACE. 1/2" INCH STAND OFFS ARE INCLUDED ON FACE OF FIREPLACE.
- 8 IF STRUCTURAL BACKER IS REQUIRED FOR FINISHING MATERIAL, COMBUSTIBLE MATERIAL IS ALLOWED IN THE AREA SHOWN BELOW THE 3" DIMENSION.
- 9 ( SHEET 1 )  
**DIMENSION SHOWN IS ALLOWABLE FINISHING DIMENSION. THIS IS THE OPENING SIZE REQUIRED TO FIT THE DECOATIVE FRAME ONTO THE FIREPLACE. FINISHING MATERIAL SHALL NOT OVERLAP DIMENSION SHOWN.**
- 10 FLAT COVERS WILL COVER THE COMPONENT ACCESS AREA. GAS AND ELECTRICAL INLETS ARE LOCATED BEHIND THESE PANELS. THESE ARE USED FOR MANUFACTURING PURPOSES AND MAY BE USED AFTER FIREPLACE INSTALLATION TO ACCESS COMPONENTS DURING SERVICE. THERE SHALL BE ACCESS FROM THE INSIDE OF THE FIREPLACE AS WELL.
- 11 GLASS SHALL NOT BE DIVIDED INTO SECTIONS. GLASS SHALL BE SAFE T TOUCH SYSTEM THAT COMPLIES WITH ANSI STANDARD Z 21.50, MAX TEMPERATURE 172°F.
- 12 FIREPLACE OPTIONS:  
FIREPLACE SHALL HAVE LINEAR FLAME DOWN THE LONG AXIS, RIBBON BURNER.  
FIREPLACE SHALL HAVE MEDIA BED LIGHTING.
- 13 FIREPLACE SHALL BE MADE USING STAINLESS STEEL MATERIAL.
- 14 FLASHING SHALL BE ON THE TOP, AND SIDES. FLASHING IS REQUIRED UNDER AIR INTAKE AND SHALL BE PROVIDED BY OTHERS. FLASHING MAY CHANGE PER FINISHING MATERIAL
- 15 ( SHEET 1 )  
OUTSIDE AIR INTAKE LOCATION.  
AIR INTAKE SHALL RUN THE LENGTH OF THE FIREPLACE.

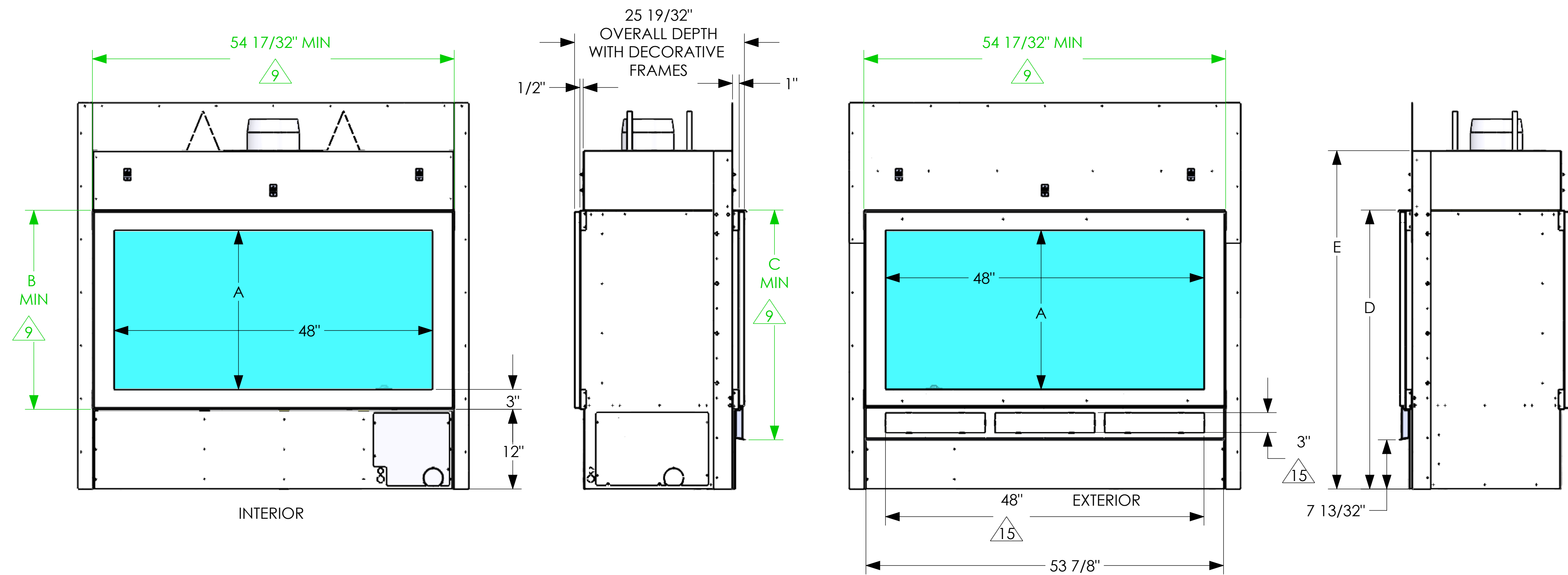
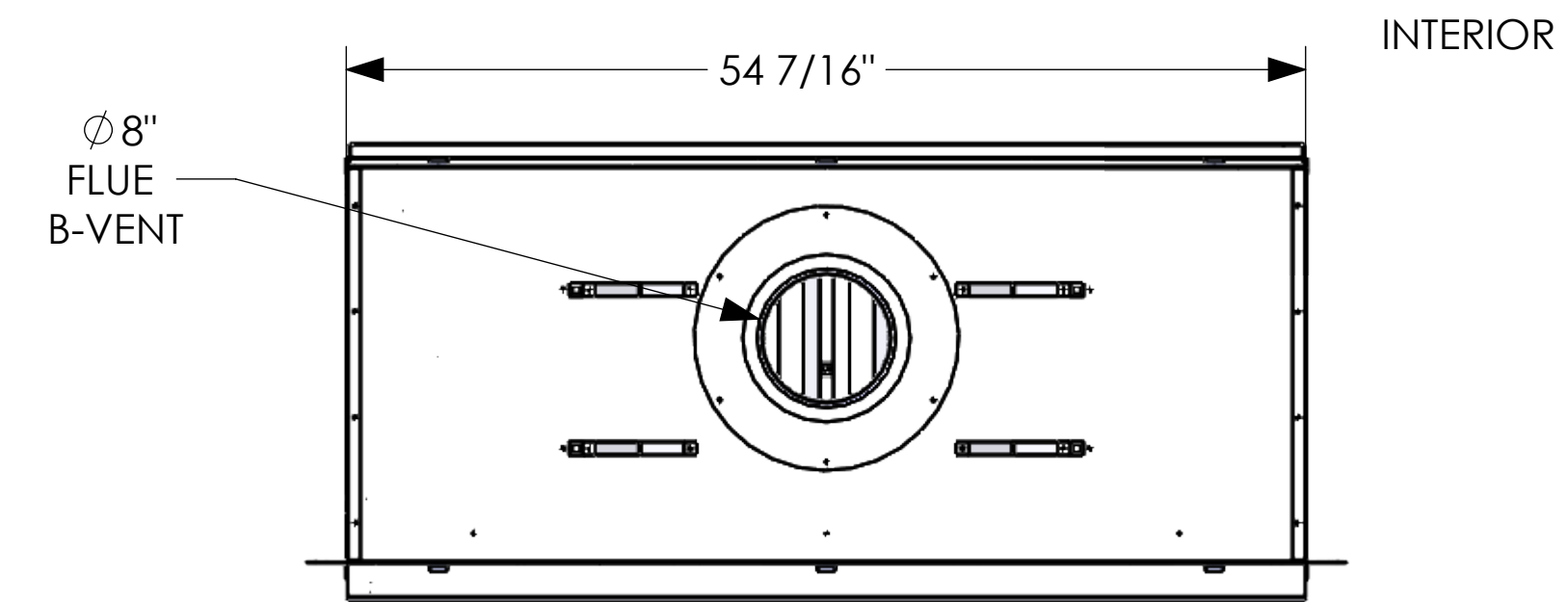
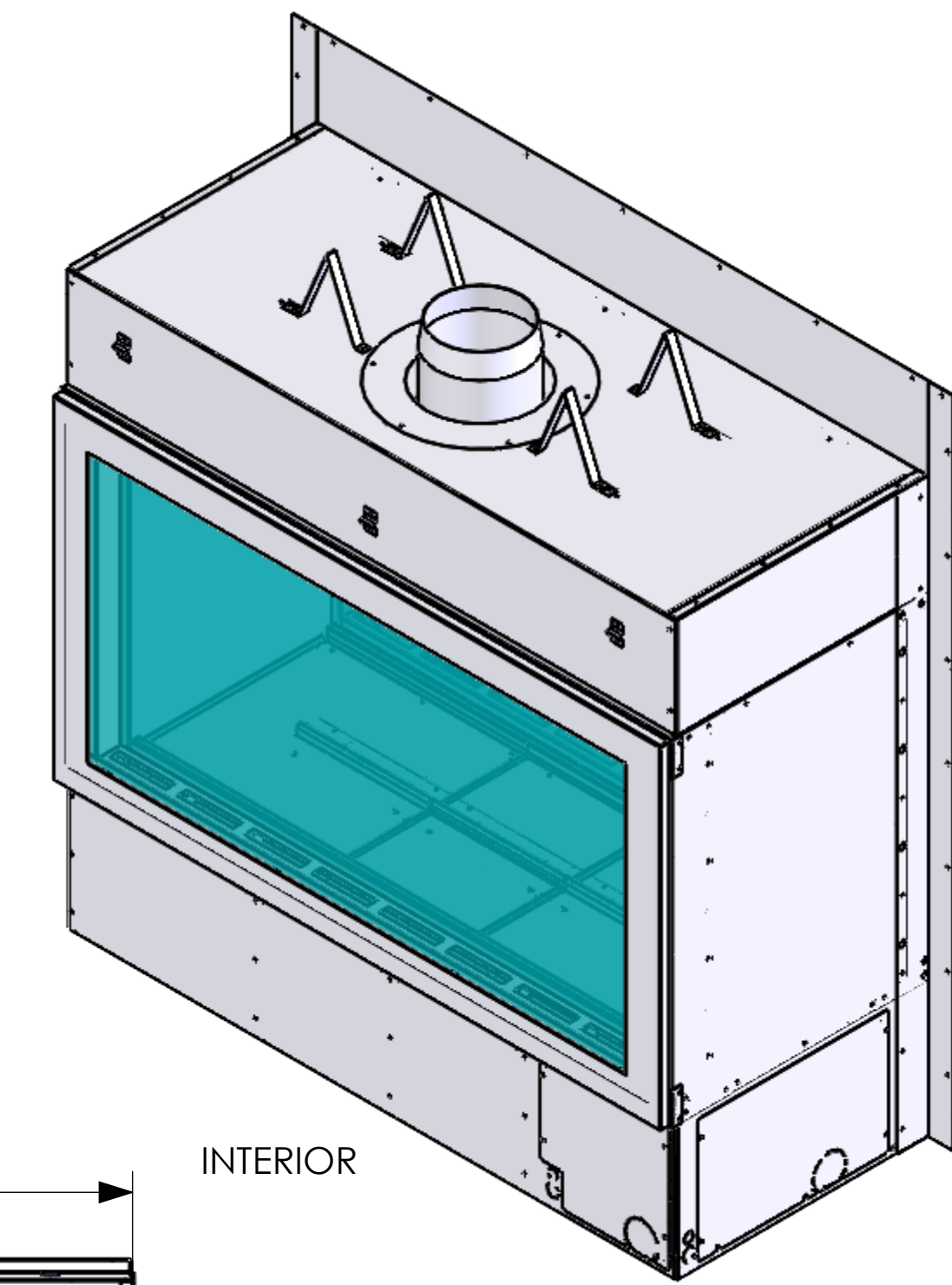

HEIGHT OPTIONS PER MODEL						
MODEL NUMBER	DIM "A"	DIM "B"	DIM "C"	DIM "D"	DIM "E"	DIM "F"
4-IDOD-24-G	24"	30"	34 5/8"	42 1/32"	51"	58 7/32"
4-IDOD-36-G	36"	42"	46 5/8"	54 1/32"	63"	70 7/32"

REV	REVISIONS	DATE	DRFT	ENG
4	CHANGE MODEL #, ADDED PAGE 3	9-14-23	SS	RB
3	INTAKE CHANGES SHOWN, ADDED ANGLE DIMENSION	8-24-22	ML	RB
2	CHANGED PROJECT NAME	4-12-22	ML	RB
1	PRELIMINARY RELEASE	3-29-22	ML	RB

UNLESS OTHERWISE SPECIFIED DIMENSIONS ARE IN INCHES: TOLERANCE - (1) PLACE DEC: ±0.1 (2) PLACE DEC: ±0.06 (3) PLACE DEC: ±0.031 ANGLE: ±2° FRACTION ±1/16  
 ← OUTSIDE MATERIAL. ○ EDGE OR INSIDE MATERIAL. ◁ OUTSIDE APEX. • INSIDE APEX. - DIMS ENCLOSED BY AN OVAL ARE CRITICAL DIMENSIONS



DRAWING AND DESIGN IS PROPERTY OF HEARTH & HOME TECHNOLOGIES

MODEL DESCRIPTION: 4' INDOOR/OUTDOOR		DATE: 3-29-22	SERIES NAME: TRANSCEND
DRAWN BY: M.LEET	ENGINEER: R.BERG	SCALE: N/A	STYLE: SHEET 1 OF 1
REV: 4		4-IDOD-SERIES	

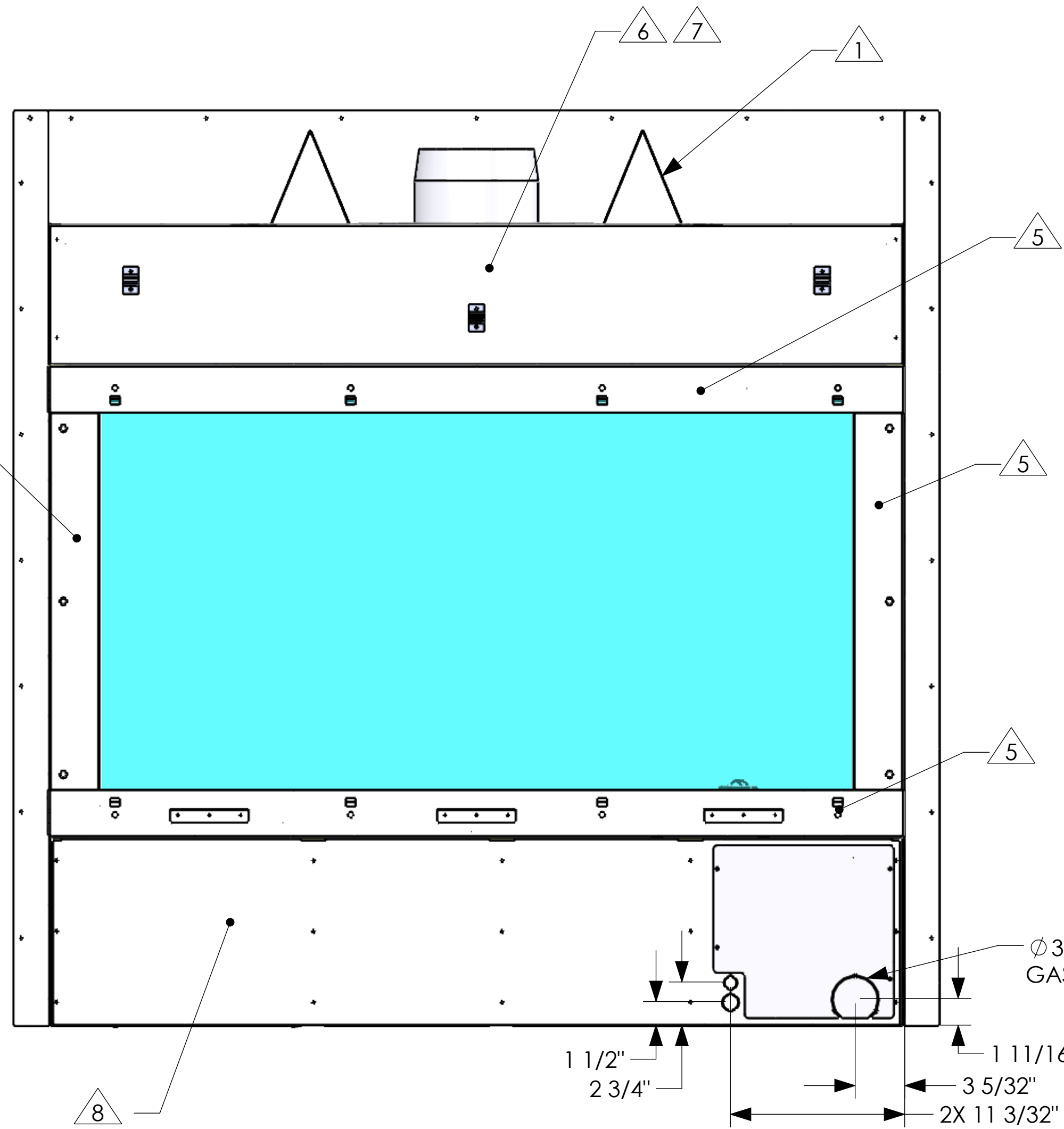

2X  $\phi$  7/8" ELECTRICAL KNOCK OUTS

2X  $\phi$  1 3/32" ELECTRICAL KNOCK OUTS

$\phi$  3" GAS KNOCK OUT

1 1/2"  
2 3/4"  
1 11/16"  
3 5/32"  
2X 11 3/32"

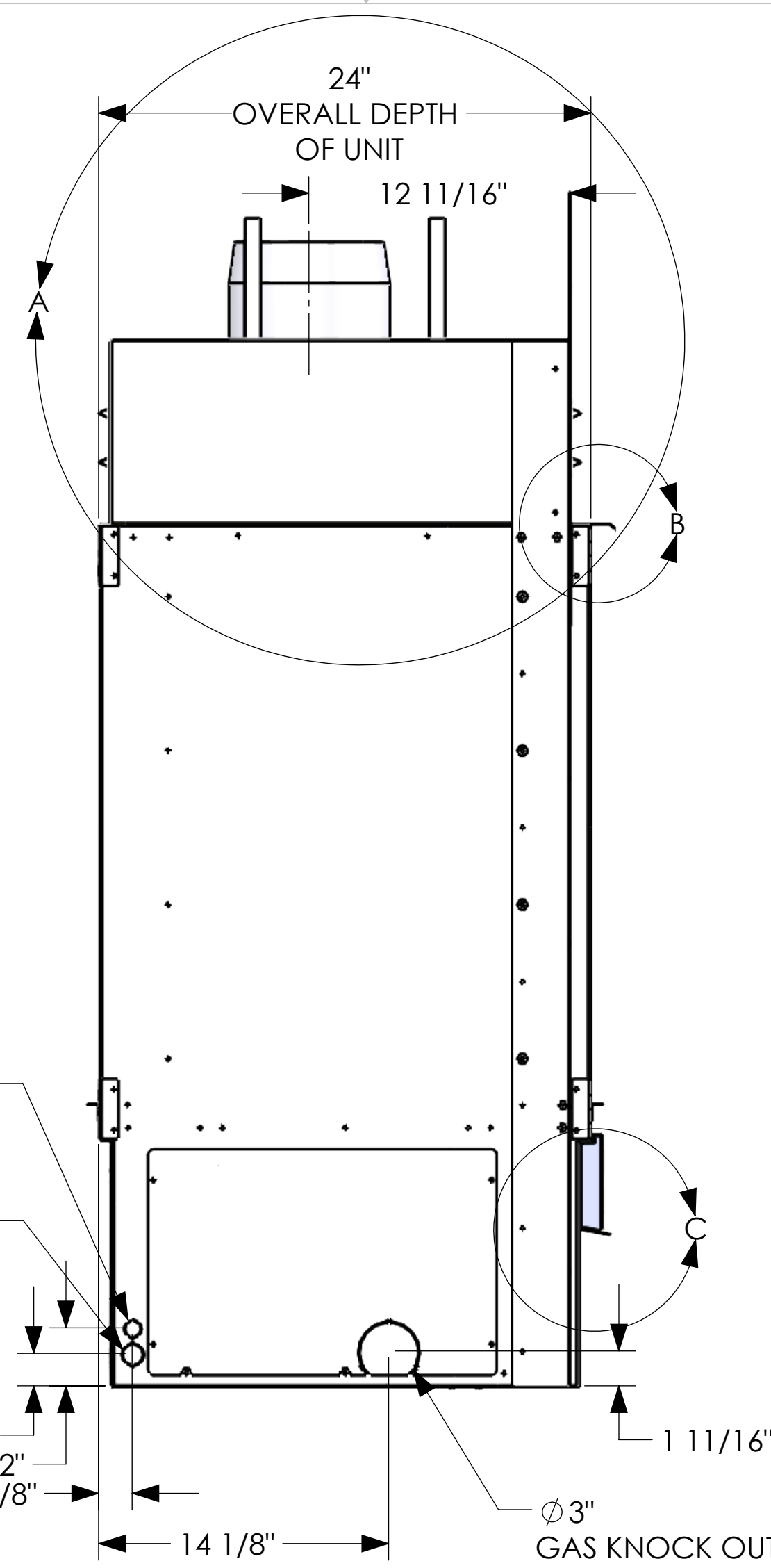

24" OVERALL DEPTH OF UNIT

12 11/16"

1 19/32"  
2 27/32"  
2X 1 5/8"  
14 1/8"  
 $\phi$  3" GAS KNOCK OUT

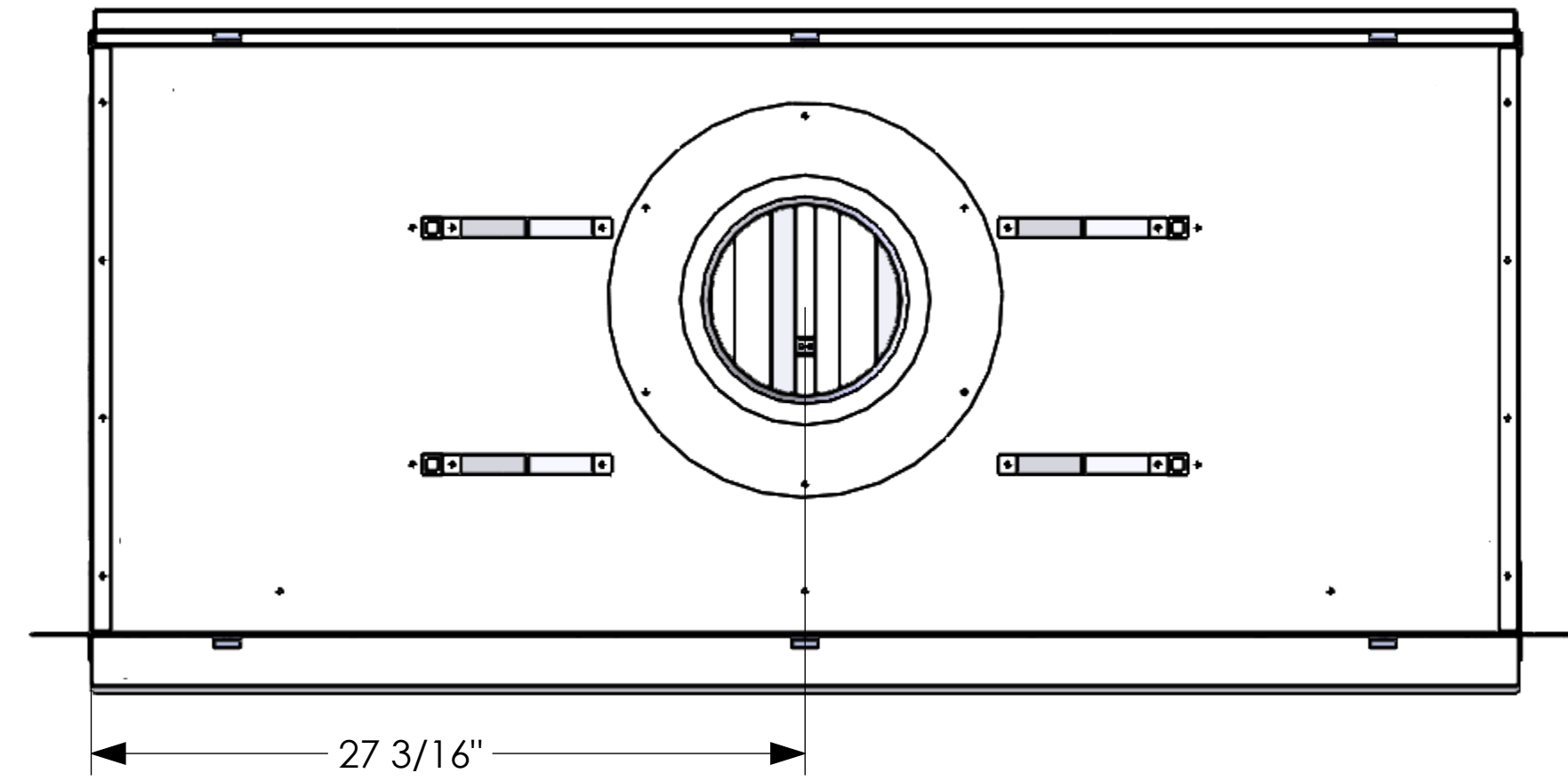

27 3/16"

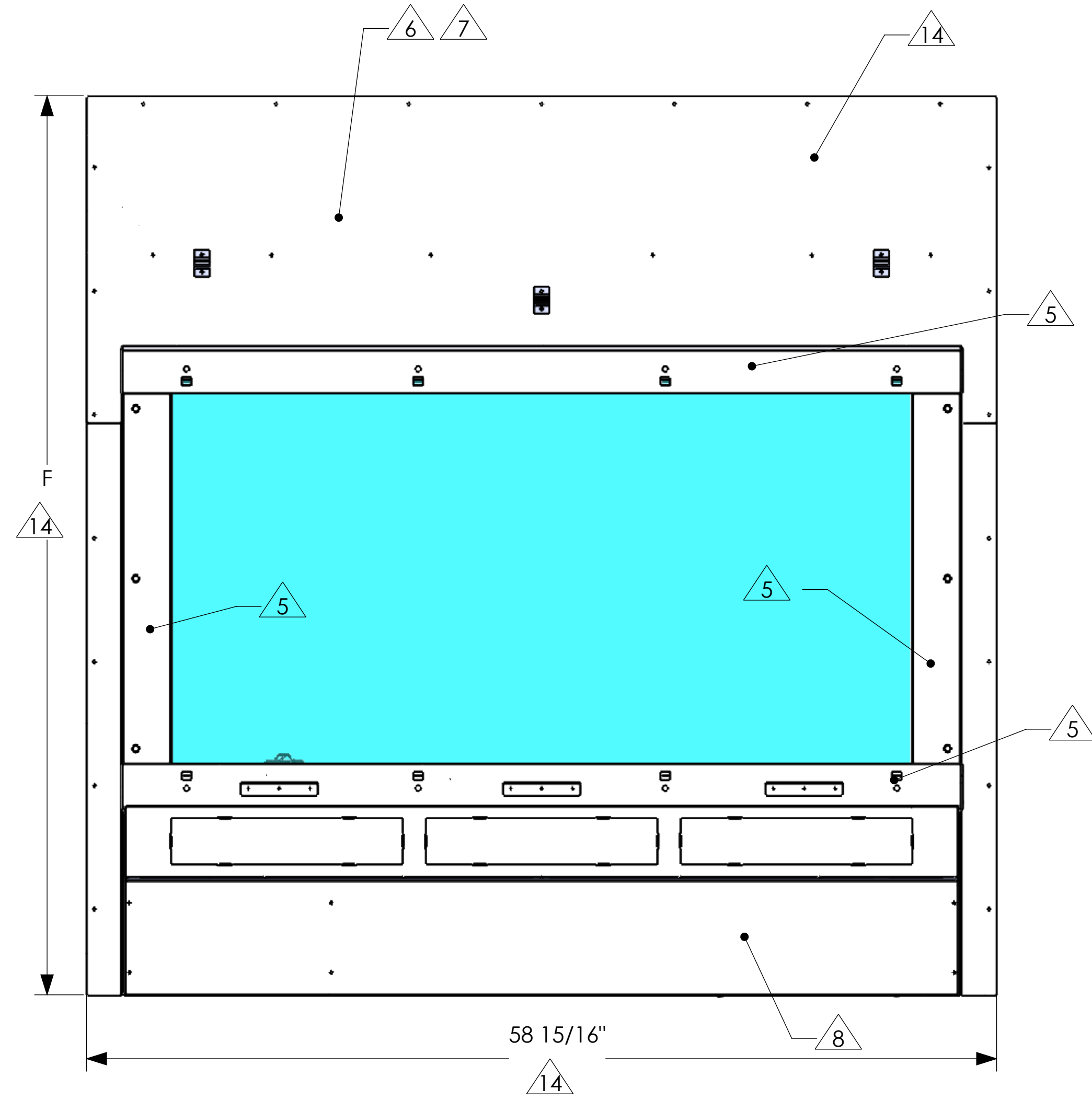

14"

14"

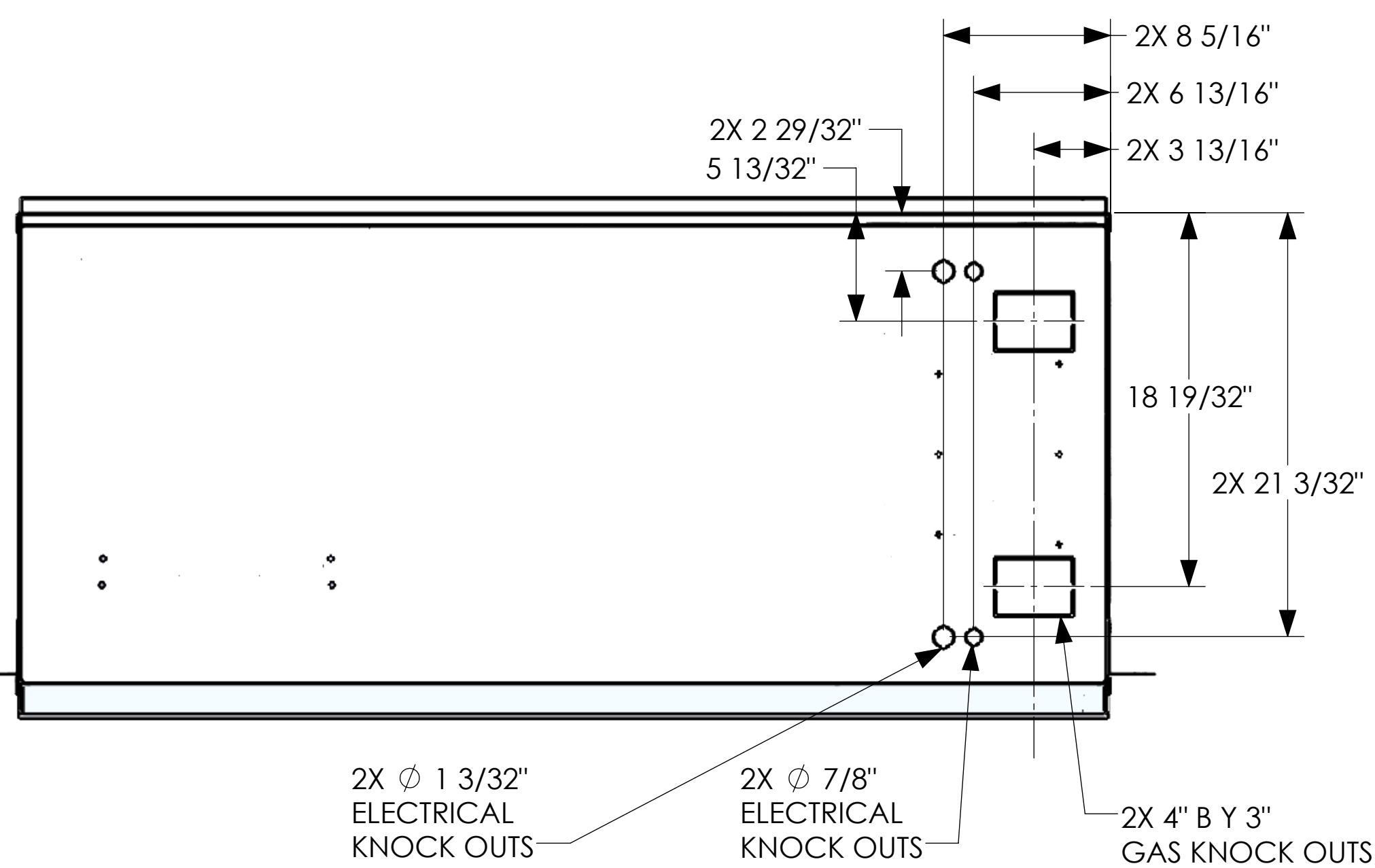

2X 2 29/32"  
5 13/32"

2X 8 5/16"  
2X 6 13/16"  
2X 3 13/16"

18 19/32"  
2X 21 3/32"

2X  $\phi$  1 3/32" ELECTRICAL KNOCK OUTS  
2X  $\phi$  7/8" ELECTRICAL KNOCK OUTS  
2X 4" B Y 3" GAS KNOCK OUTS

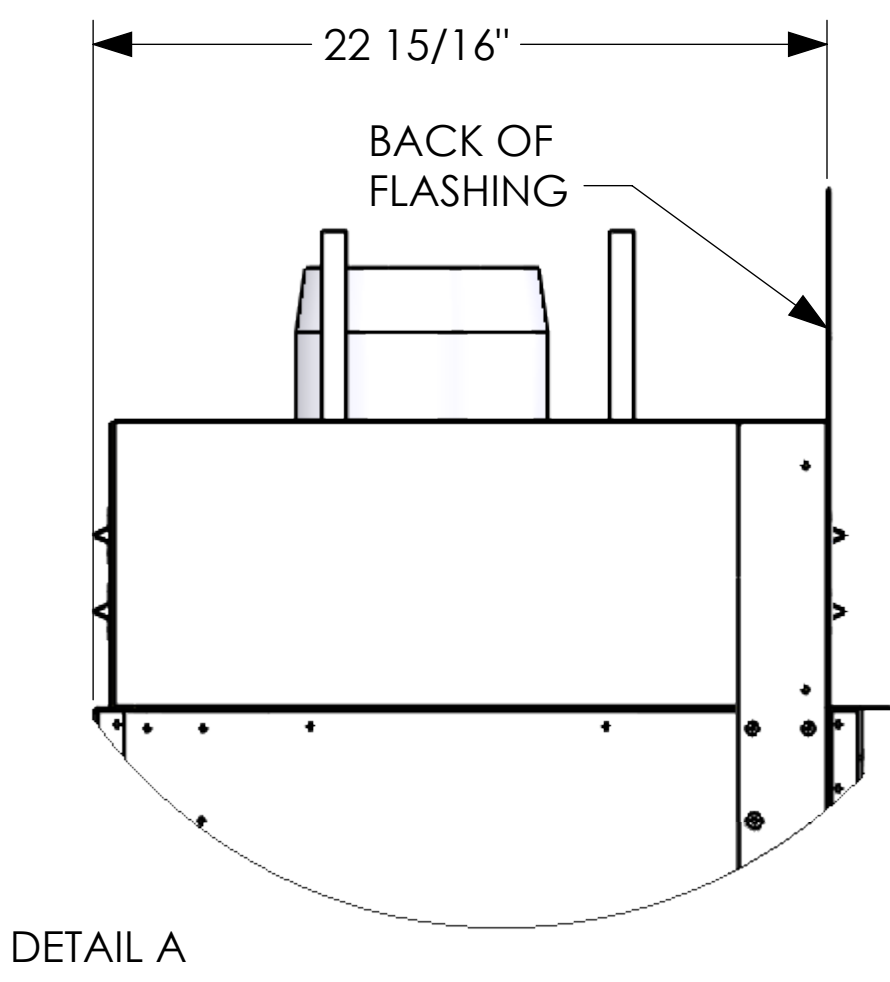

DETAIL A

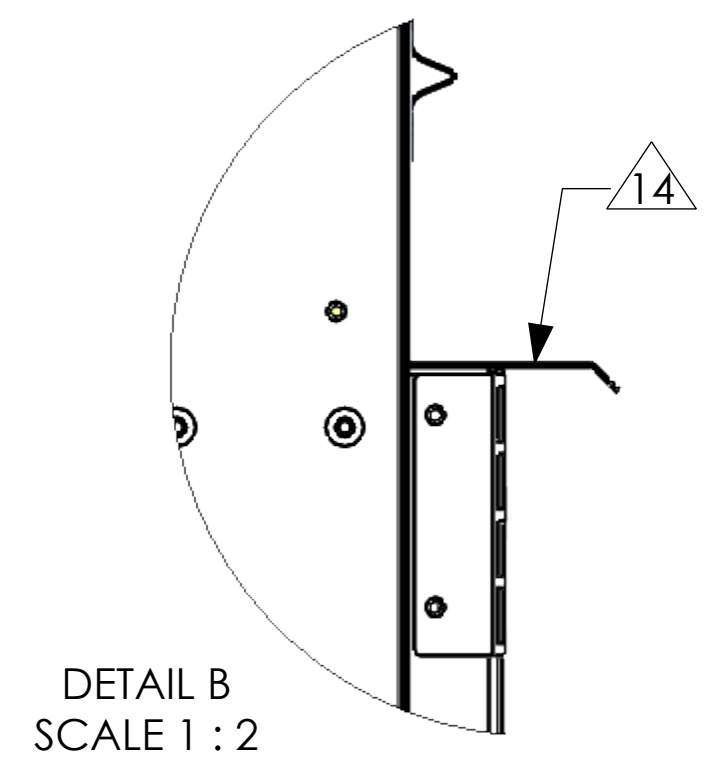

DETAIL B SCALE 1 : 2

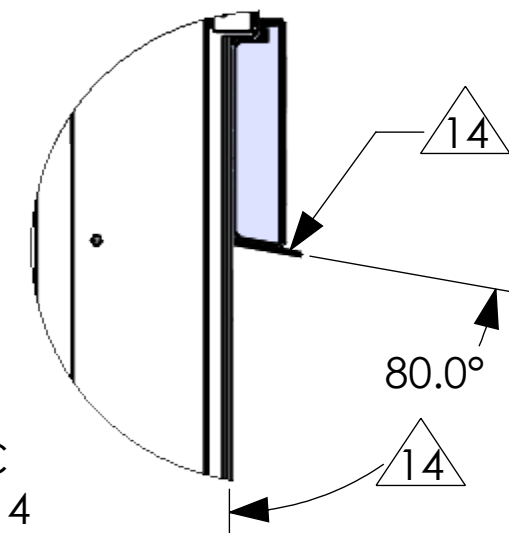

DETAIL C SCALE 1 : 4

UNLESS OTHERWISE SPECIFIED DIMENSIONS ARE IN INCHES: TOLERANCE - (1) PLACE DEC:  $\pm 0.1$  (2) PLACE DEC:  $\pm 0.06$  (3) PLACE DEC:  $\pm 0.031$  ANGLE:  $\pm 2^\circ$  FRACTION  $\pm 1/16$   
 ◀ OUTSIDE MATERIAL. ○ EDGE OR INSIDE MATERIAL. ◄ OUTSIDE APEX. ● INSIDE APEX. - DIMS ENCLOSED BY AN OVAL ARE CRITICAL DIMENSIONS

**STELLAR**  
by Heat & Glo

DRAWING AND DESIGN IS PROPERTY OF HEARTH & HOME TECHNOLOGIES

MODEL DESCRIPTION:		4' INDOOR/OUTDOOR			
DRAWN BY:	DATE:	SERIES NAME:			
M.LEET	3-29-22	TRANSCEND			
ENGINEER:	SCALE:	SHEET:	STYLE:	REV:	
R.BERG	N/A	SHEET 2 OF 1	4-IDOD-SERIES	4	

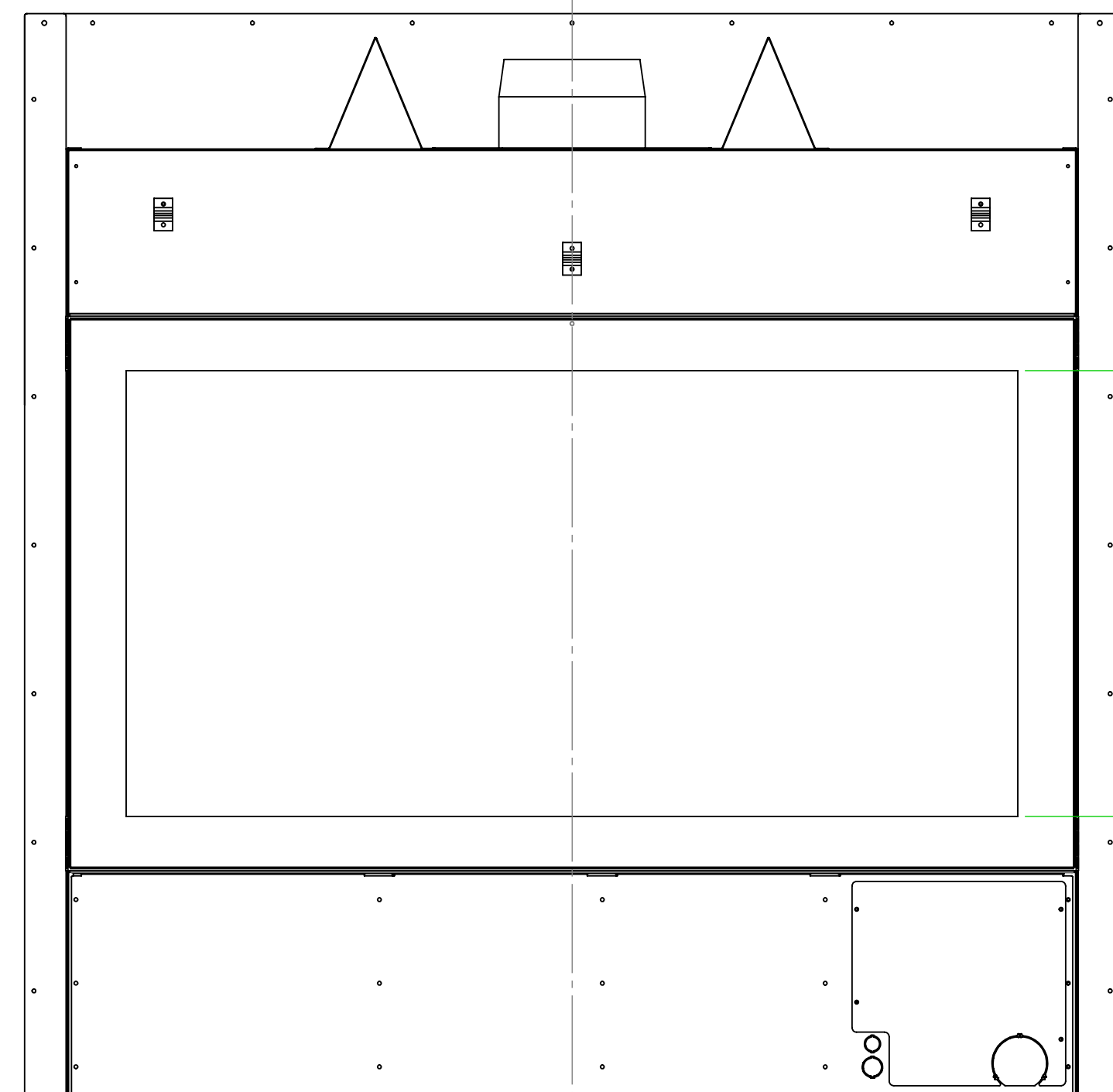

4-IDOD-24-G

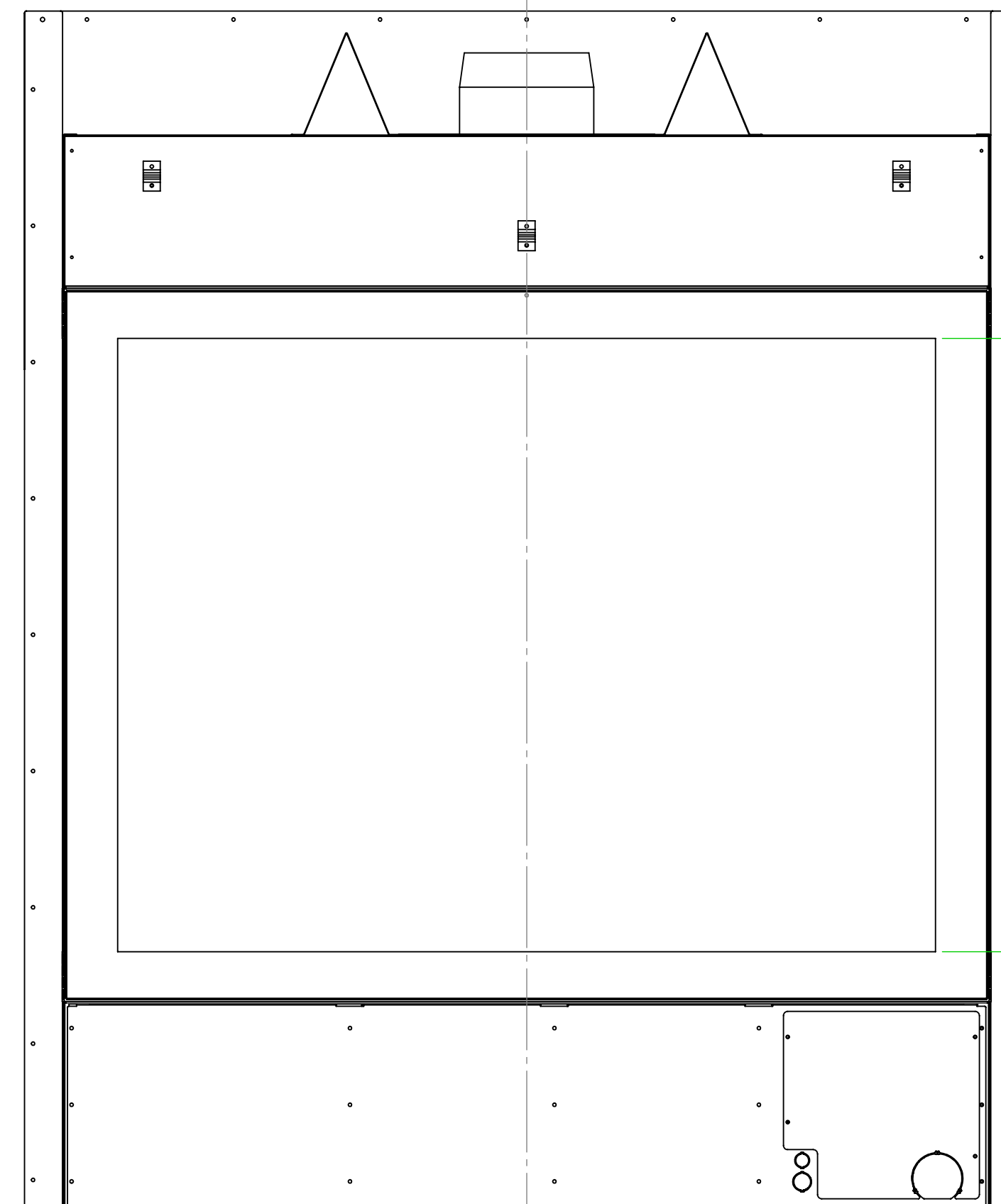

4-IDOD-36-G

UNLESS OTHERWISE SPECIFIED DIMENSIONS ARE IN INCHES: TOLERANCE - (1) PLACE DEC: ±0.1 (2) PLACE DEC: ±0.06 (3) PLACE DEC: ±0.031 ANGLE: ±2° FRACTION ±1/16  
 ◀ OUTSIDE MATERIAL. ○ EDGE OR INSIDE MATERIAL. ◁ OUTSIDE APEX. • INSIDE APEX. - DIMS ENCLOSED BY AN OVAL ARE CRITICAL DIMENSIONS



DRAWING AND DESIGN IS PROPERTY OF HEARTH & HOME TECHNOLOGIES

PART NAME: 48 X 24 SEE THRU		DATE: 2-19-20		MATERIAL:	
DRAWN BY: M.LEET		SCALE: N/A		SHEET: SHEET 3 OF 1	
ENGINEER: R.BERG		PART NUMBER: 4-IDOD-SERIES		REV: 3	