

## PRODUCT SPECIFICATIONS

# 2461 Large Convection Wood Stove

# DUTCHWEST



### ACTUAL DIMENSIONS

Unit Depth: 16" (410 mm)

Unit Height: 30" (760 mm)

Unit Width: 25 3/4" (654 mm)

### TECHNICAL INFORMATION

Log Length: up to 22" (560 mm)

Burn Time: up to 9 hours

Heating Capacity: up to 1,600 sq. ft. (150 m<sup>2</sup>)

Maximum Heat Output: 40,000 BTUs/hr.

Efficiency Rating: 76%

EPA Emissions Rating: 1.4 grams/hr.

Weight: 436 lbs. (198 kg)

Flue Collar: 6" (152.4 mm) round, reversible

Firebox Volume: 2.2 cubic feet (.06 m<sup>3</sup>)

Clearances (with optional shields)

Back: 14" (355.6 mm) measured to back of stove top

Corner: 15" (381 mm)

Side: 22" (560 mm)

### FIELD INSTALLED ACCESSORIES

- Dual speed convection fan
- Rear heat shield
- Fan thermostat
- Fan rheostat
- Short legs - 2" (50.8 mm) height
- Stove surface thermometer
- Warming shelf

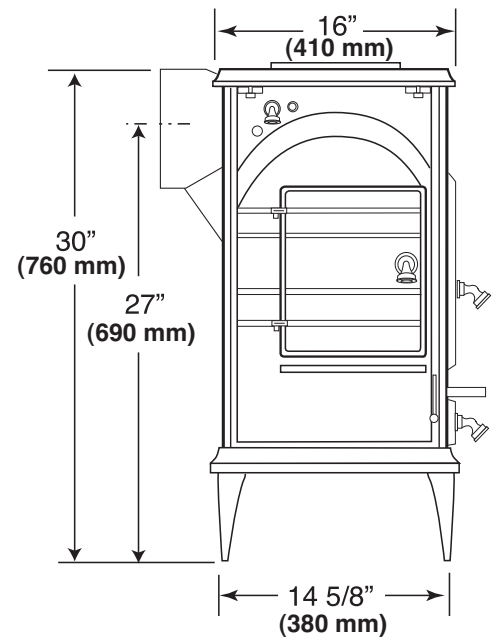
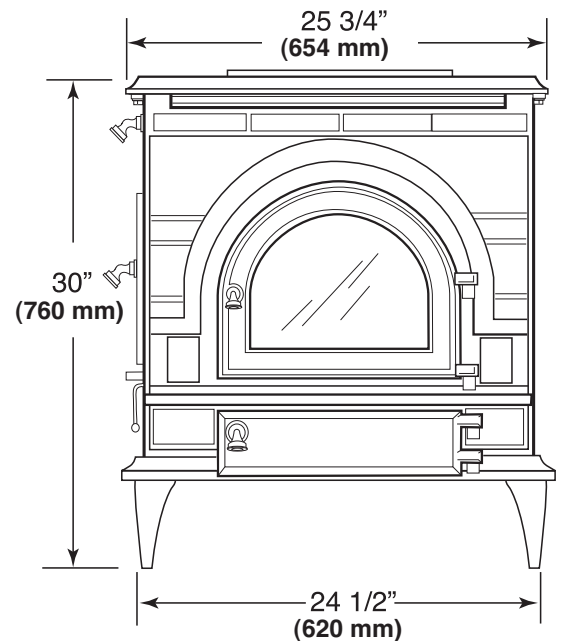

A Brand of Monessen Hearth Systems Co.  
149 Cleveland Drive, Paris, Kentucky 40361  
[www.majesticproducts.com](http://www.majesticproducts.com)

SEE BACK FOR MORE INFORMATION

## PRODUCT SPECIFICATIONS

# 2461 Large Convection Wood Stove (continued)

# DUTCHWEST

## STOVE CLEARANCES

	UNPROTECTED SURFACE <sup>3</sup>			PROTECTED SURFACE <sup>3</sup>		
	Parallel Installation		Corner Installation	Parallel Installation		Corner Installation
	Side (A)	Rear (B)	Corner (C)	Side (D)	Rear (E)	Corner (F)
No heat shields	22" (560 mm)	24" (610 mm)	18" (460 mm)	12" (300 mm)	14" (360 mm)	10" (250 mm)
Rear exit, rear heat shield only	22" (560 mm)	14" (360 mm)	N/A	12" (300 mm)	12" (300 mm)	N/A
Top exit, rear heat shield only <sup>1</sup>	22" (560 mm)	24" (610 mm)	18" (460 mm)	12" (300 mm)	14" (360 mm)	10" (250 mm)
Top exit, rear heat shield, single wall, connector shields <sup>1,2</sup>	22" (560 mm)	14" (360 mm)	15" (380 mm)	12" (300 mm)	12" (300 mm)	8" (203 mm)
Top exit, rear heat shield, double wall <sup>1</sup>	22" (560 mm)	19" (480 mm)	15" (380 mm)	12" (300 mm)	11" (280 mm)	8" (203 mm)

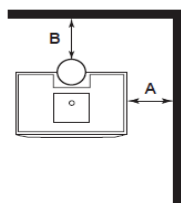

Stove installed parallel to wall

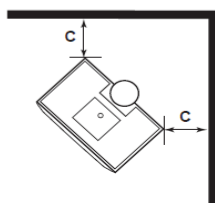

Stove installed in corner

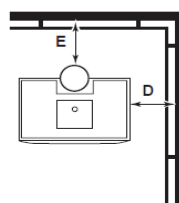

Stove installed parallel

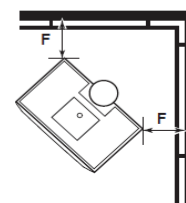

Stove installed in corner

<sup>1</sup>Shielding for a top exit stove must include a shield insert to protect the area behind the flue collar.

<sup>2</sup>Chimney connector heat shields must extend exactly 24" (610 mm) above the flue collar of the stove.

<sup>3</sup>All installations venting straight up to a factory built chimney require a 24" (610 mm) diameter or square ceiling heat shield. The ceiling heat shield should be 24 gauge sheet metal or equivalent mounted on 1" (25 mm) non-combustible spacers 1" (25 mm) below the ceiling.



To avoid personal injury or property damage, the product described by this brochure must be installed, operated and maintained in strict compliance with the instructions packaged with the product and all applicable building or fire codes. Contact local building or fire officials about restrictions and installation inspection requirements. All photographs and drawings on this brochure are for illustrative purposes only and are not intended for, nor should they be used as a substitute for the instructions packaged with the unit. Appearance and specifications of the product are subject to change without notice. © 2011 Monessen Hearth Systems Co. 0611v1