

QUADRA-FIRE®

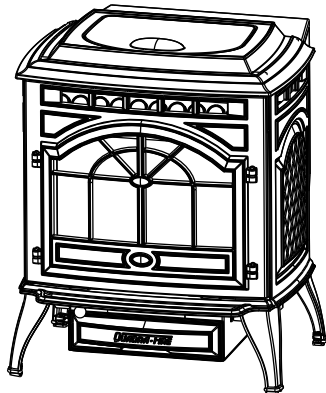

CASTILE & SANTA FE PELLET STOVE

Owner's Manual Installation and Operation



Models:
CASTILE-CE-MBK
SANTAFE-CE-MBK

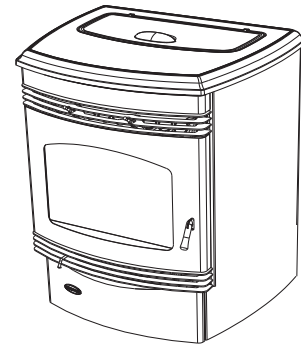

CAUTION



DO NOT DISCARD THIS MANUAL

- Important operating and maintenance instructions included.
- Read, understand and follow these instructions for safe installation and operation.
- Leave this manual with party responsible for use and operation.



⚠ WARNING



Please read this entire manual before installation and use of this pellet fuel-burning room heater. Failure to follow these instructions could result in property damage, bodily injury or even death.

- Do not store or use gasoline or other flammable vapors and liquids in the vicinity of this or any other appliance.
- Do not overfire - If any external part starts to glow, you are overfiring. Reduce feed rate. Overfiring will void your warranty.
- Comply with all minimum clearances to combustibles as specified. Failure to comply may cause house fire.

⚠ WARNING



HOT SURFACES!

Glass and other surfaces are hot during operation AND cool down.

Hot glass will cause burns.

- Do not touch glass until it is cooled
- NEVER allow children to touch glass
- Keep children away
- CAREFULLY SUPERVISE children in same room as fireplace.
- Alert children and adults to hazards of high temperatures.

High temperatures may ignite clothing or other flammable materials.

- Keep clothing, furniture, draperies and other flammable materials away.

CAUTION

Fuel Type: Wood Pellets, less than 38mm in length, 6mm to 8mm in diameter.

Burning of any other type of fuel voids your warranty.

CAUTION

Check building codes prior to installation.

- All local regulations, including those referring to national and European standards need to be complied with when installing the appliance.
- Consult local fire officials or authorities having jurisdiction about restrictions, installation inspection, and permits.

Congratulations 

and Welcome to the Quadra-Fire Family!

Hearth & Home Technologies welcomes you to our tradition of excellence! In choosing a Quadra-Fire appliance, you have our assurance of commitment to quality, durability, and performance.



This commitment begins with our research of the market, including 'Voice of the Customer' contacts, ensuring we make products that will satisfy your needs. Our Research and Development facility then employs the world's most advanced technology to achieve the optimum operation of

our stoves, inserts and fireplaces. And yet we are old-fashioned when it comes to craftsmanship. Each unit is meticulously fabricated and surfaces are hand-finished for lasting beauty and enjoyment. Our pledge to quality is completed as each model undergoes a quality control inspection.

We wish you and your family many years of enjoyment in the warmth and comfort of your hearth appliance. Thank you for choosing Quadra-Fire.

NOTE: Consult insurance carrier, local building inspector, fire officials or authorities having jurisdiction over restrictions, installation inspection and permits.



| | | |
|--|---|---|
|  |  |  <small>1445 North Highway - Colville, WA 99114 - USA</small> |
| SANTA FE CE PELLET STOVE | | |
| Nominal heat output: Puissance nominale: Nominaal vermogen: | Max: 7,9 kW Min: 3,0 kW | |
| CO emission (at 13% O2): Des émissions de CO (à 13% O2): CO-uitstoot (bij 13% O2): | Max: 0,003% Min: 0,008% | |
| Efficiency: Efficacité: Efficiëntie: | Max: 82,1% Min: 77,5% | |
| Flue gas temperature: Température des fumées: Rookgastemperatuur: | 161°C | |
| Max electrical power supply: Max approvisionnement électrique: Max elektrische voeding: | 470 W | |
| Rated Voltage: Tension nominale: Nominale spanning: | 230 V - 50 Hz | |
| Safety clearance distance (back): Distance de dégagement de sécurité (retour): Veiligheidsafstand afstand (terug): | 50 mm | |
| Safety clearance distance (side): Distance de dégagement de sécurité (côté): Veiligheidsafstand afstand (zijde): | 160 mm | |

Use only recommended fuels. Utilisez uniquement des combustibles recommandés. Gebruik alleen aanbevolen brandstoffen.



Read and follow the operating instructions! Lisez et suivez les instructions d'utilisation! Lees en volg de gebruiksaanwijzing!

SERIAL NO. / NUMÉRO DE SÉRIE / SERIENUMMER
 007030

| | | | | | | | | | | | | | | |
|--------------------------|--------------------------|--------------------------|--------------------------|--------------------------|--------------------------|--------------------------|--------------------------|--------------------------|--------------------------|--------------------------|--------------------------|--------------------------|--------------------------|--------------------------|
| 2011 | 2012 | 2013 | JAN | FEB | MAR | APR | MAY | JUN | JUL | AUG | SEP | OCT | NOV | DEC |
| <input type="checkbox"/> | <input type="checkbox"/> | <input type="checkbox"/> | <input type="checkbox"/> | <input type="checkbox"/> | <input type="checkbox"/> | <input type="checkbox"/> | <input type="checkbox"/> | <input type="checkbox"/> | <input type="checkbox"/> | <input type="checkbox"/> | <input type="checkbox"/> | <input type="checkbox"/> | <input type="checkbox"/> | <input type="checkbox"/> |

7068-111



| | | |
|--|--|---|
|  |  |  <small>1445 North Highway - Colville, WA 99114 - USA</small> |
| CASTILE CE PELLET STOVE | | |
| Nominal heat output: Puissance nominale: Nominaal vermogen: | Max: 7,9 kW Min: 3,0 kW | |
| CO emission (at 13% O2): Des émissions de CO (à 13% O2): CO-uitstoot (bij 13% O2): | Max: 0,003% Min: 0,008% | |
| Efficiency: Efficacité: Efficiëntie: | Max: 82,1% Min: 77,5% | |
| Flue gas temperature: Température des fumées: Rookgastemperatuur: | 161°C | |
| Max electrical power supply: Max approvisionnement électrique: Max elektrische voeding: | 470 W | |
| Rated Voltage: Tension nominale: Nominale spanning: | 230 V - 50 Hz | |
| Safety clearance distance (back): Distance de dégagement de sécurité (retour): Veiligheidsafstand afstand (terug): | 50 mm | |
| Safety clearance distance (side): Distance de dégagement de sécurité (côté): Veiligheidsafstand afstand (zijde): | 160 mm | |

Use only recommended fuels. Utilisez uniquement des combustibles recommandés. Gebruik alleen aanbevolen brandstoffen.

Read and follow the operating instructions! Lisez et suivez les instructions d'utilisation! Lees en volg de gebruiksaanwijzing!

SERIAL NO. / NUMÉRO DE SÉRIE / SERIENUMMER
 007028

| | | | | | | | | | | | | | | |
|--------------------------|--------------------------|--------------------------|--------------------------|--------------------------|--------------------------|--------------------------|--------------------------|--------------------------|--------------------------|--------------------------|--------------------------|--------------------------|--------------------------|--------------------------|
| 2011 | 2012 | 2013 | JAN | FEB | MAR | APR | MAY | JUN | JUL | AUG | SEP | OCT | NOV | DEC |
| <input type="checkbox"/> | <input type="checkbox"/> | <input type="checkbox"/> | <input type="checkbox"/> | <input type="checkbox"/> | <input type="checkbox"/> | <input type="checkbox"/> | <input type="checkbox"/> | <input type="checkbox"/> | <input type="checkbox"/> | <input type="checkbox"/> | <input type="checkbox"/> | <input type="checkbox"/> | <input type="checkbox"/> | <input type="checkbox"/> |

7070-100

Safety Alert Key:

- **DANGER!** Indicates a hazardous situation which, if not avoided will result in death or serious injury.
- **WARNING!** Indicates a hazardous situation which, if not avoided could result in death or serious injury.
- **CAUTION!** Indicates a hazardous situation which, if not avoided, could result in minor or moderate injury.
- **NOTICE:** Indicates practices which may cause damage to the appliance or to property.

TABLE OF CONTENTS

Congratulations2
 Sample of Safety/Serial Numer Label2
 Safety Alert Key.....3
 Limited Warranty4-5

Section 1: Listing and Code Approvals

A. Appliance Certifications.....6
 B. Glass Specifications.....6
 C. Electrical Rating6
 D. Specifications6

User’s Guide

Section 2: Operating Instructions

A. Fire Safety.....7-8
 B. Combustible/Non-Combustible Material.....8
 C. Fuel Material & Fuel Storage8
 D. General Operation Information.....9
 E. Before Your First Fire.....9
 F. Filling the Hopper with Fuel.....9
 G. Starting Your First Fire9-10
 H. Fire Characteristics10
 I. Flame Height Adjustment (Feed Rate).....10
 J. Ignition Cycles.....10
 K. Clear Space10

Section 3: Maintaining & Servicing Appliance

A. Proper Shutdown Procedures11
 B. Quick Reference Maintenance Chart.....11
 C. General Maintenance & Cleaning11-14
 D. High Ash Fuel Content Maintenance15

Section 4: Troubleshooting for Homeowner

A. Frequently Asked Questions16

Installer’s Guide

Section 5: Getting Started

A. Design, Installation & Location
 Considerations and Floor Support17
 B. Thermostat Location18
 C. Tools & Supplies Needed.....18
 D. Inspect Appliance and Components18
 E. Pre-Burn Checklist18

Section 6: Dimensions & Clearances

A. Appliance Dimensions.....19
 B. Clearance to Combustibles20
 C. Hearth Protection21

Section 7: Vent Information

A. Venting Termination Requirements.....22
 B. Avoiding Smoke and Odors22-23
 C. Negative Pressure.....23
 D. Draft23
 E. Chimney & Exhaust Connection24
 F. Pellet Venting Charts25

Section 8: Venting Systems

A. Alcove26
 B. Vertical - Interior.....27
 C. Through the Wall & Vertical - External27
 D. Vertical Into Existing Class A Chimney.....27
 E. Masonry28
 F. Alternate Masonry28
 G. Through the Wall.....29

Section 9: Appliance Set-Up

A. Outside Air Installation30
 B. Log Set Placement (Optional).....31
 C. Thermostat Installation.....31

Contact Information32

**Hearth & Home Technologies Inc.
LIMITED LIFETIME WARRANTY**

Hearth & Home Technologies Inc., on behalf of its hearth brands ("HHT"), extends the following warranty for HHT gas, wood, pellet, coal and electric hearth appliances that are purchased from an HHT authorized dealer.

WARRANTY COVERAGE:

HHT warrants to the original owner of the HHT appliance at the site of installation, and to any transferee taking ownership of the appliance at the site of installation within two years following the date of original purchase, that the HHT appliance will be free from defects in materials and workmanship at the time of manufacture. After installation, if covered components manufactured by HHT are found to be defective in materials or workmanship during the applicable warranty period, HHT will, at its option, repair or replace the covered components. HHT, at its own discretion, may fully discharge all of its obligations under such warranties by replacing the product itself or refunding the verified purchase price of the product itself. The maximum amount recoverable under this warranty is limited to the purchase price of the product. This warranty is subject to conditions, exclusions and limitations as described below.

WARRANTY PERIOD:

Warranty coverage begins on the date of installation. In the case of new home construction, warranty coverage begins on the date of first occupancy of the dwelling or six months after the sale of the product by an independent, authorized HHT dealer/ distributor, whichever occurs earlier. The warranty shall commence no later than 24 months following the date of product shipment from HHT, regardless of the installation or occupancy date. The warranty period for parts and labor for covered components is produced in the following table.

The term "Limited Lifetime" in the table below is defined as: 20 years from the beginning date of warranty coverage for gas appliances, and 10 years from the beginning date of warranty coverage for wood, pellet, and coal appliances. These time periods reflect the minimum expected useful lives of the designated components under normal operating conditions.

| Warranty Period | | HHT Manufactured Appliances and Venting | | | | | | | Components Covered |
|------------------|---------|---|------|--------|----------|------|----------|---------|--|
| Parts | Labor | Gas | Wood | Pellet | EPA Wood | Coal | Electric | Venting | |
| 1 Year | | X | X | X | X | X | X | X | All parts and material except as covered by Conditions, Exclusions, and Limitations listed |
| 2 years | | | | X | X | X | | | Igniters, electronic components, and glass |
| | | X | X | X | X | X | | | Factory-installed blowers |
| | | | X | | | | | | Molded refractory panels |
| 3 years | | | | X | | | | | Firepots and burnpots |
| 5 years | 1 year | | | X | X | | | | Castings and baffles |
| 7 years | 3 years | | X | X | X | | | | Manifold tubes, HHT chimney and termination |
| 10 years | 1 year | X | | | | | | | Burners, logs and refractory |
| Limited Lifetime | 3 years | X | X | X | X | X | | | Firebox and heat exchanger |
| 90 Days | | X | X | X | X | X | X | X | All replacement parts beyond warranty period |

See conditions, exclusions, and limitations on next page.

WARRANTY CONDITIONS:

- This warranty only covers HHT appliances that are purchased through an HHT authorized dealer or distributor. A list of HHT authorized dealers is available on the HHT branded websites.
- This warranty is only valid while the HHT appliance remains at the site of original installation.
- Contact your installing dealer for warranty service. If the installing dealer is unable to provide necessary parts, contact the nearest HHT authorized dealer or supplier. Additional service fees may apply if you are seeking warranty service from a dealer other than the dealer from whom you originally purchased the product.
- Check with your dealer in advance for any costs to you when arranging a warranty call. Travel and shipping charges for parts are not covered by this warranty.

WARRANTY EXCLUSIONS:

This warranty does not cover the following:

- Changes in surface finishes as a result of normal use. As a heating appliance, some changes in color of interior and exterior surface finishes may occur. This is not a flaw and is not covered under warranty.
- Damage to printed, plated, or enameled surfaces caused by fingerprints, accidents, misuse, scratches, melted items, or other external sources and residues left on the plated surfaces from the use of abrasive cleaners or polishes.
- Repair or replacement of parts that are subject to normal wear and tear during the warranty period. These parts include: paint, wood, pellet and coal gaskets; firebricks; grates; flame guides; and the discoloration of glass.
- Minor expansion, contraction, or movement of certain parts causing noise. These conditions are normal and complaints related to this noise are not covered by this warranty.
- Damages resulting from: (1) failure to install, operate, or maintain the appliance in accordance with the installation instructions, operating instructions, and listing agent identification label furnished with the appliance; (2) failure to install the appliance in accordance with local building codes; (3) shipping or improper handling; (4) improper operation, abuse, misuse, continued operation with damaged, corroded or failed components, accident, or improperly/incorrectly performed repairs; (5) environmental conditions, inadequate ventilation, negative pressure, or drafting caused by tightly sealed constructions, insufficient make-up air supply, or handling devices such as exhaust fans or forced air furnaces or other such causes; (6) use of fuels other than those specified in the operating instructions; (7) installation or use of components not supplied with the appliance or any other components not expressly authorized and approved by HHT; (8) modification of the appliance not expressly authorized and approved by HHT in writing; and/or (9) interruptions or fluctuations of electrical power supply to the appliance.
- Non-HHT venting components, hearth components or other accessories used in conjunction with the appliance.
- Any part of a pre-existing fireplace system in which an insert or a decorative gas appliance is installed.
- HHT's obligation under this warranty does not extend to the appliance's capability to heat the desired space. Information is provided to assist the consumer and the dealer in selecting the proper appliance for the application. Consideration must be given to appliance location and configuration, environmental conditions, insulation and air tightness of the structure.

This warranty is void if:

- The appliance has been over-fired or operated in atmospheres contaminated by chlorine, fluorine, or other damaging chemicals. Over-firing can be identified by, but not limited to, warped plates or tubes, rust colored cast iron, bubbling, cracking and discoloration of steel or enamel finishes.
- The appliance is subjected to prolonged periods of dampness or condensation.
- There is any damage to the appliance or other components due to water or weather damage which is the result of, but not limited to, improper chimney or venting installation.

LIMITATIONS OF LIABILITY:

- The owner's exclusive remedy and HHT's sole obligation under this warranty, under any other warranty, express or implied, or in contract, tort or otherwise, shall be limited to replacement, repair, or refund, as specified above. In no event will HHT be liable for any incidental or consequential damages caused by defects in the appliance. Some states do not allow exclusions or limitation of incidental or consequential damages, so these limitations may not apply to you. This warranty gives you specific rights; you may also have other rights, which vary from state to state. EXCEPT TO THE EXTENT PROVIDED BY LAW, HHT MAKES NO EXPRESS WARRANTIES OTHER THAN THE WARRANTY SPECIFIED HEREIN. THE DURATION OF ANY IMPLIED WARRANTY IS LIMITED TO DURATION OF THE EXPRESSED WARRANTY SPECIFIED ABOVE.

1 Listing and Code Approvals

A. Appliance Certification

| | |
|-----------------|---|
| Model | Santa Fe or Castile Pellet Appliance |
| Type | Residential Space heating appliance fired by wood pellets |
| Standard | EN 14785:2006 |



B. Glass Specifications

This appliance is equipped with 5mm ceramic glass. Replace glass only with 5mm ceramic glass. Please contact your dealer for replacement glass.

C. Electrical Rating

230 VAC, 50 Hz, Start 2.80 Amps, Run 0.80 Amps

NOTE: Some generator or battery back-up systems may not be compatible with the micro-processor electronics on this appliance. Please consult the power supply manufacturer for compatible systems.

NOTICE: Hearth & Home Technologies, manufacturer of this appliance, reserves the right to alter its products, their specifications and/or price without notice.

D. Specifications

| | |
|---|--|
| Distance to Adjacent Combustion Materials: | Standoff to Rear: 50mm Standoff to Side: 160mm |
| CO Concentration at 13% | Max: 0.003 Min: 0.030 |
| Flue Gas Temperature: | 161°C |
| *Thermal Output: | Max: 6.3 kW Min: 3.0 kW |
| Energy Efficiency: | Max: 75.1% Min: 75.0% |
| Heating Capacity: | 220m ² to 350m ² |
| Hopper Capacity: | 18 kg |
| Fuels: | Wood Pellets, less than 38mm in length, 6mm to 8mm in diameter |
| Shipping Weight: | 109 kg, add 18 kg when the hopper is full |

*Thermal output will vary, depending on the type of fuel you use in your appliance. Consult your Quadra-Fire dealer for best results.

WARNING! Risk of Fire! Hearth & Home Technologies disclaims any responsibility for, and the warranty and agency listing will be voided by the above actions.

DO NOT:

- Install or operate damaged appliance
- Modify appliance
- Use as an incinerator or any other different way from which it was conceived
- Install other than as instructed by Hearth & Home Technologies
- Operate the appliance without fully assembling all components
- Overfire
- Install any component not approved by Hearth & Home Technologies
- Install parts or components not Listed or approved.

Improper installation, adjustment, alteration, service or maintenance can cause injury or property damage.

For assistance or additional information, consult a qualified installer, service agency or your dealer.

Quadra-Fire is a registered trademark of Hearth & Home Technologies

User's Guide

2 Operating Instructions

WARNING



HOT SURFACES!

Glass and other surfaces are hot during operation AND cool down.

Hot glass will cause burns.

- Do not touch glass until it is cooled
- NEVER allow children to touch glass
- Keep children away
- CAREFULLY SUPERVISE children in same room as appliance.
- Alert children and adults to hazards of high temperatures.

High temperatures may ignite clothing or other flammable materials.

- Keep clothing, furniture, draperies and other flammable materials away.

WARNING! Do not operate appliance before reading and understanding the operating instructions in the Owner's Manual. Failure to operate appliance according to operating instructions could cause fire or injury.

A. Fire Safety

To provide reasonable fire safety, the following should be given serious consideration:

- Install at least one smoke detector and CO monitor on each floor of your home.
- Locate detectors away from the heating appliance and close to the sleeping areas.
- Follow the detector's manufacturer's placement and installation instructions and maintain regularly.
- Conveniently locate a fire extinguisher to contend with small fires.
- In the event of a hopper fire:
 - Evacuate the house immediately.
 - Notify fire department.

B. Combustible/Non-Combustible Materials

• **Combustible Material**

Material made of or surfaced with wood, compressed paper, plant fibers, plastics, or any material capable of igniting and burning, whether flame-proofed or not, plastered or unplastered.

• **Non-combustible Material**

Material which will not ignite and burn. Such materials are those consisting entirely of steel, iron, brick, tile, slate, glass or plasters, or any combination thereof.

• **Firestop Non-combustible Sealant Material**

Sealants which will not ignite and burn.

C. Fuel Material and Fuel Storage

Pellet fuel quality can greatly fluctuate. We recommend that you buy fuel in multi-ton lots whenever possible. However, we do recommend trying various brands before purchasing multi-ton lots to ensure your satisfaction.

Fuel Material

- Made from sawdust or wood by-products
- Depending on the source material it may have a high or low ash content.

Higher Ash Content Material

- Hardwoods with a high mineral content
- Fuel that contains bark
- Standard grade pellets and high ash pellets

Lower Ash Content Material

- Softwoods
- Fuels with low mineral content
- Premium grade pellets

CAUTION! Do not burn fuel that contains an additive; (such as soybean oil).

- May cause hopper fires
- Damage to product may result

Clinkers

Minerals and other non-combustible materials such as sand will turn into a hard, glass-like substance called a clinker when heated in the firepot.

Trees from different areas will vary in mineral content. That is why some fuels produce more clinkers than others.

Moisture

Always burn dry fuel. Burning fuel with high moisture content takes heat from the fuel and tends to cool the appliance, robbing heat from your home. Damp pellet fuel can clog the feed system.

Size

- Pellets are either 6 or 8mm in diameter
- Length should be no more than 38mm
- Pellet lengths can vary from lot to lot from the same manufacturer
- Due to length variations, the flame height (feed rate) may need adjusting occasionally. See **page 10** for instructions.

Performance

- Higher ash content requires the ash drawer to be emptied more frequently
- Hardwoods require more air to burn properly
- Premium wood pellets produce the highest heat output.
- Burning pellets longer than 38mm can cause an inconsistent fuel feed rate and/or missed ignitions.

CAUTION! Tested and approved for wood pellets. Burning of any other type of fuel voids your warranty.

Storage

- Wood pellets should be left in their original sealed bag until using to prevent moisture absorption.
- Do not store any pellet fuel within the clearance requirements or in an area that would hinder routine cleaning and maintenance.

D. General Operating Information

1. Thermostat Calls For Heat

The appliance is like most modern furnaces; when the thermostat calls for heat, your appliance will automatically light and deliver heat. When the room is up to temperature and the thermostat is satisfied, the red call light will go off and the appliance will shut down.

2. Heat Output Controls

This appliance is equipped with a heat output control switch that has three settings or burn rates; low, medium and high. The appliance will turn on and off as the thermostat demands. When the thermostat calls for heat, the appliance will start up at the burn rate for which it is set. If the appliance is set at one of the lower settings, it will run quieter but take longer to heat up an area than if it were set at a higher burn rate. Regardless of the burn rate, when the area is warm enough to satisfy the thermostat, the appliance will shut off.

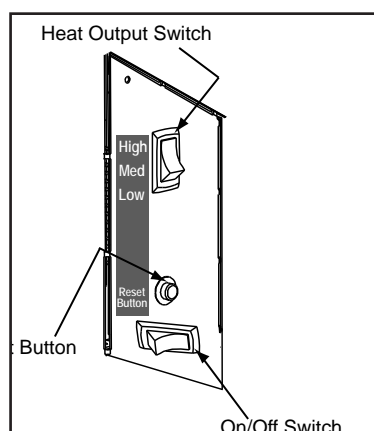

Figure 9.1

| | |
|--|--|
| | <h2>WARNING</h2> |
| | <p>Fire Hazard. Keep combustible materials, gasoline and other flammable vapors and liquids clear of appliance.</p> <ul style="list-style-type: none"> • Do NOT store flammable materials in the appliance's vicinity. • DO NOT USE GASOLINE, LANTERN FUEL, KEROSENE, CHARCOAL LIGHTER FLUID OR SIMILAR LIQUIDS TO START OR "FRESHEN UP" A FIRE IN THIS HEATER. • DO NOT BURN GARBAGE OR FLAMMABLE FLUIDS SUCH AS GASOLINE, NAPHTHA OR ENGINE OIL. • DO NOT USE CHEMICALS OF FLUIDS TO START THE FIRE. • Keep all such liquids well away from the heater while it is in use. • Combustible materials may ignite. |

E. Before Your First Fire

1. First, make sure your appliance has been properly installed and that all safety requirements have been met. Pay particular attention to the fire protection, venting and thermostat installation instructions.
2. Double check that the ash drawer and firebox are empty!
3. Close the front door.

IMPORTANT DETAIL: The tip of the thermocouple must be in contact with the inside end of the thermocouple cover or missed ignitions can occur.

F. Filling the Hopper with Fuel

1. Open the hopper lid and pull the lid towards you. The lid can now serve as a shelf to support the bag of fuel.
2. Do not over fill the hopper. The lid must be completely closed to maintain proper vacuum and for the feed motor to operate. An error message will appear on the wall control if the lid is not properly closed.
3. Remove any sawdust or fuel from the lid gasket after refilling hopper.
4. Do not leave any part of the fuel bag on the appliance after refilling hopper.
5. Store fuel away from the appliance to maintain proper safe air clearance to combustibles.

G. Starting Your First Fire

1. A thermostat is required for proper operation of this appliance. At this time, fill the hopper with pellets, set the thermostat to its lowest setting. Plug the power cord into nearby outlet.
2. The exhaust blower will stay on for approximately 18 minutes even though the thermostat is not calling for heat. This is normal.
3. Locate the heat output control switch mounted on the back of the appliance in the upper right corner. **Figure 9.1.** Turn it to the "high" setting by pushing the top of the control switch in and then adjust the thermostat to its highest setting. Remove the right side panel and the red call light located to the left of the control box will be on. **Figure 10.1.** This indicates the thermostat is calling for heat.
4. The fuel feed system and the igniter should now be on.
5. For your first fire it will be necessary to press the reset button once approximately 2 minutes after start up and again in 5 minutes. This will fill the feed system and allow the appliance to begin dropping pellets. The appliance will continue to run as long as the thermostat is calling for heat.

- Once the appliance has ignited, let it burn for approximately 15 minutes, then set the thermostat to the desired room temperature. Adjust the heat output control switch to the desired setting.

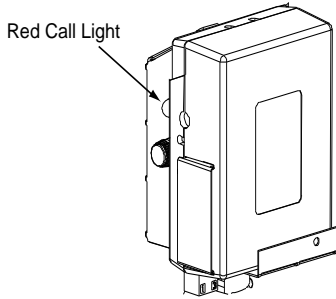

Figure 10.1

H. Fire Characteristics

A properly adjusted fire with the heat output control switch set on “high” has a short active flame pattern that extends out of the firepot approximately 102mm. If the fire has tall flames with black tails and seems somewhat lazy, the feed rate will need to be reduced. This is done by sliding the fuel adjustment control rod down, which will reduce the feed. If the fire is not 102mm tall, slide the fuel adjustment control rod up to increase the feed. A medium and low setting will give a shorter flame. The flame will rise and fall somewhat. This is normal.

I. Feed Rate Adjustment Instructions

The feed adjustment control rod is factory set, and should be adequate for most fuels. However, if the flame height is too high or too low, you will need to adjust the feed rate. Wait until the appliance has been burning for 15 minutes before making your adjustments and allow 15 minutes for feed adjustment to take effect.

- Loosen the set screw 1/4 to 1/2 turn during set-up of appliance. This will allow movement of the feed adjustment control rod. Do not re-tighten set screw.
- Loosen the wing nut.
- Adjust the feed adjustment control rod upward towards the “+” symbol to increase the feed rate and flame height or down towards the “-” symbol, to decrease the feed rate and flame height. **Figure 10.2.**
- Re-tighten the wing nut.

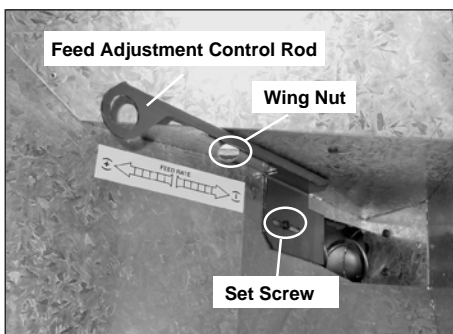



Figure 10.2

J. Ignition Cycles

- At the beginning of each ignition cycle, it is normal to see some smoke in the firebox. The smoke will stop once the fire starts.
- The convection blower will automatically turn on after your appliance has been burning for approximately 10 minutes. This blower transfers heat from your appliance into the room, and will continue to run after the thermostat has stopped calling for heat until the appliance has cooled down.
- Occasionally the appliance may run out of fuel and shut itself down. When this happens, the red call light will be on. **Figure 10.1.** To restart it, fill the hopper and press the reset button. **See Figure 9.1 on page 9.** When you press the reset button the red call light will go out. Release the button and the light will come back on. You should see a fire shortly. If not, follow the instructions on **page 9** of “Starting Your First Fire”.

| | |
|--|--|
|  WARNING | |
|  | Fire Risk |
| | Do NOT operate appliance: <ul style="list-style-type: none"> • With appliance door open. • Firepot floor open. • Cleaning slide plates open. |
| | Do NOT store fuel: <ul style="list-style-type: none"> • Closer than required clearances to combustibles to appliance • Within space required for loading or ash removal. |

K. Clear Space

WARNING! RISK OF FIRE! Do NOT place combustible objects in front of the appliance. High temperatures may ignite clothing, furniture or draperies. Maintain a minimum clearance of 914mm in front of appliance.

Mantel: Avoid placing candles and other heat-sensitive objects on mantel or hearth. Heat may damage these objects.

NOTICE: Clearances may only be reduced by means approved by the regulatory authority having jurisdiction.

WARNING! RISK OF FIRE! Keep combustible materials, gasoline and other flammable vapors and liquids clear of appliance.

- Do NOT store flammable materials in the appliance’s vicinity.
- Do NOT use gasoline, lantern fuel, kerosene, charcoal lighter fluid or similar liquids to start or “freshen up” a fire in this heater.

Keep all such liquids well away from the heater while it is in use as combustible materials may ignite.

3 Maintaining & Servicing Your Appliance

A. Proper Shutdown Procedure

CAUTION

Shock and Smoke Hazard

- Turn down thermostat, let appliance completely cool and exhaust blower must be off. Now you can unplug appliance before servicing.
- Smoke spillage into room can occur if appliance is not cool before unplugging.
- Risk of shock if appliance not unplugged before servicing appliance.

Follow the detailed instructions found in this section for each step listed as referenced in the chart below.

B. Quick Reference Maintenance Chart

| Cleaning or Inspection | Frequency | | Daily | Weekly | Monthly | Yearly |
|---------------------------------------|--|----|-------|--------|---------|--------|
| Ash Pan | Every 5 bags of fuel or more frequently depending on the fuel type or ash build-up | OR | | X | | |
| Ash Removal from Firebox | Every 5 bags or more frequently depending on the fuel type or ash build-up | OR | | X | | |
| Beneath Heat Exchanger | Every 1 ton of fuel | OR | | | X | |
| Blower, Combustion (Exhaust) | More frequently depending on the fuel type | OR | | | | X |
| Blower, Convection | 25 bags or more frequently depending on operating environment. | OR | | | X | |
| Door Latch Inspection | Prior to heating season | OR | | | X | |
| Exhaust Path | 25 bags or more frequently depending on ash build-up | OR | | | X | |
| Firebox - Prepare for Non-Burn Season | At end of heating season | OR | | | | X |
| Firepot - Burning pellets - hardwood | Every 3 bags | OR | X | | | |
| Firepot - Burning pellets - softwood | Every 5 bags | OR | X | | | |
| Glass | When clear view of firepot becomes obscure | OR | | X | | |
| Heat Exchanger & Drop Tube | Every 15 bags | OR | | X | | |
| Hopper | Every 50 bags of fuel or when changing fuel types | OR | | | X | |
| Top Vent Adapter | More frequently depending on the fuel type or ash build-up | OR | | | | X |
| Venting System | More frequently depending on the fuel type | OR | | | | X |

C. General Maintenance

1. Types of Fuel

Depending on the type of fuel you are burning will dictate how often you have to clean your firepot.

If the fuel you are burning has a high dirt or ash content it may be necessary to clean the firepot more than once a day.

Dirty fuel will cause clinkers to form in the firepot. A clinker is formed when dirt, ash or a non-burnable substance is heated to 1093°C and becomes glass-like. See **page 16** in this section for more details on fuels with high ash content.

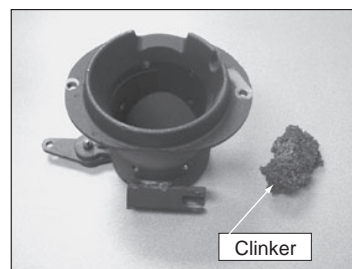



Figure `12.1 - Clinker

NOTICE: These are recommendations. Clean more frequently if you encounter heavy build-up of ash at the recommended interval or you see soot coming from the vent. **Not properly cleaning your appliance on a regular basis will void your warranty.**

2. Cleaning Firepot with Cleaning Rod & Firepot Clean-Out Tool

- **Frequency:** Daily or more often as needed
- **By:** Homeowner
 - a. The appliance must be in complete shutdown and cool and the exhaust blower off. If you are just cleaning the firepot, there is no need to unplug the appliance.
 - b. Pull firepot cleaning rod OUT a couple of times to help shake debris loose. If rod is hard to pull, it may be necessary to use your firepot clean-out tool to chip away material that has built up on the bottom plate of the firepot and to push out any clinkers. Larger clinkers may have to be removed from the top of the firepot.
 - c. The firepot floor plate must be fully closed when finished.

| | |
|---|---|
|  | WARNING |
| | Fire Risk |
| | NEVER pull firepot cleaning rod or cleaning slide plates out when appliance is operating. |
| | <ul style="list-style-type: none"> • The cleaning slide plates must be fully CLOSED when appliance is operating. • Hot pellets may fall into ashpan and start a fire or mis-starts due to lack of vacuum. |

3. Ash Removal from Firebox

- **Frequency:** Weekly or every 5 bags or more frequently depending on ash build-up.
- **By:** Homeowner
 - a. There must not be any hot ashes in the firebox during cleaning so allow the appliance to completely cool. The firebox ash should be removed every time the exhaust path is cleaned. Frequent cleaning of the ash in the firebox will help slow down the build-up of ash in the exhaust blower and vent system.
 - b. Plug in your appliance, if unplugged, and turn the thermostat on and immediately shut it off to start the exhaust blower on its cycle time. It will pull fly ash out the exhaust instead of into the room.
 - c. Open cast hinged face. Directly underneath the firebox door and to the left and right of the firepot are 2 cleaning slide plates with finger holes. Pull both slide plates out and then open the glass door. Sweep the remaining ash from the firebox into the 2 open holes. A paint brush works well for this. Close slide plates.
 - d. This ash is deposited in the same ash pan as the firepot debris. The ash pan should be emptied every time you clean the firebox. Remember to place the ash and debris into a metal or noncombustible container.
 - e. The 2 cleaning slide plates must be fully closed when cleaning is complete. **See Disposal of Ashes.**

4. Cleaning Ash Pan/Drawer

- **Frequency:** Every 5 bags or weekly or more frequently depending on ash build-up.
- **By:** Homeowner

Locate the ash pan/drawer underneath the firepot. Open the bottom ash door and slide the ash pan straight out. Empty into a non-combustible container and re-install ash pan/drawer. **See Disposal of Ashes.**

5. Disposal of Ashes

- **Frequency:** As needed
- **By:** Homeowner

Ashes should be placed in a metal container with a tight-fitting lid. The closed container of ashes should be placed on a non-combustible floor or on the ground, well away from all combustible materials, pending final disposal.

If the ashes are disposed of by burial in soil or otherwise locally dispersed, they should be retained in the closed container until all cinders have been thoroughly cooled.



| | |
|--|---|
|  | WARNING |
| | Disposal of Ashes |
| | <ul style="list-style-type: none"> • Ashes should be placed in metal container with tight fitting lid. • Ashes should be retained in closed container until all cinders have thoroughly cooled. |

6. Cleaning Beneath Heat Exchanger

- **Frequency:** Monthly or after burning 1 ton of fuel
- **By:** Homeowner
 - a. Be sure the appliance is allowed to cool, has been unplugged and the exhaust blower is off
 - b. A more thorough cleaning is needed to remove the excess ash that is left behind from the use of the cleaning rods for the heat exchanger tubes.
 - c. The ash will be resting on the back of the baffle. This will require removing the cast baffle.

7. Cleaning Heat Exchanger Chambers & Drop Tube

- **Frequency:** Weekly or every 15 bags or more frequently depending on ash build-up
- **By:** Homeowner

| | |
|---|--|
|  | WARNING |
|  | Heat exchanger cleaning rods may be warm to the touch. For safety purposes wear gloves. |
|  | Do not pull heat exchanger cleaning rods while appliance is operating. Push cleaning rods IN when done, DO NOT leave cleaning rods OUT. Injury can occur. |

The amount of ash buildup in the firepot will be a good guide to determine how often you should clean the heat exchangers.

- Allow the appliance to completely cool down before pulling the cleaning rods. Turn the thermostat on and then immediately off to start the exhaust blower on its cycle time. It will pull fly ash out the exhaust instead of into the room.
- Locate the 2 exposed rods directly underneath the heat exchanger tubes. **Figure 14.1.**
- To clean, pull the rods straight out until it stops, approximately 203mm. Slide the rods OUT and IN a couple of times.

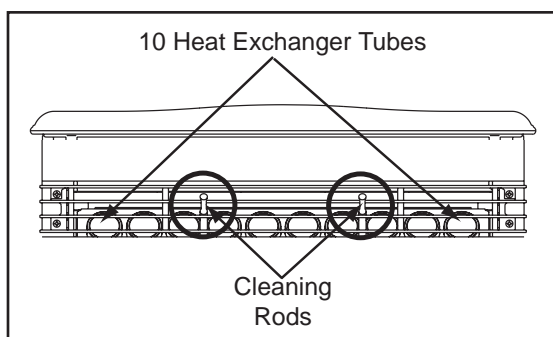

Figure 14.1

8. Door Latch Inspection

- **Frequency:** Prior to heating season or monthly during heating season
- **By:** Homeowner

The door latch is non-adjustable but the gasketing between the glass and firebox should be inspected periodically to make sure there is a good seal.

9. Cleaning the Exhaust Path

- **Frequency:** Every 25 bags or monthly or more frequently depending on ash build-up.
- **By:** Homeowner
 - Appliance must be completely cool.
 - Open cast hinge face. Remove baffle and right brick and thoroughly vacuum the area and continue throughout the rest of the firebox.
 - Replace right brick and baffle and close cast hinge face.

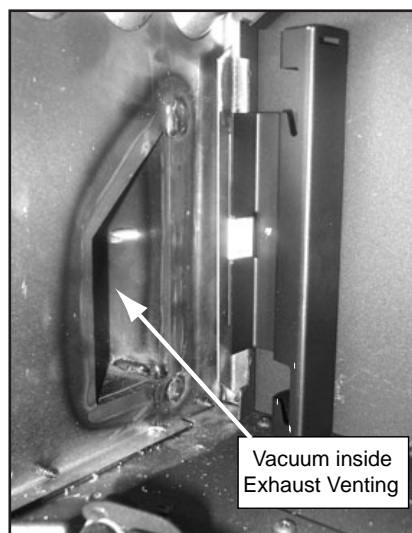

Figure 14.2

10. Cleaning the Hopper

- **Frequency:** Monthly or after burning 50 bags of fuel
- **By:** Homeowner

After burning approximately 1 ton of fuel you will need to clean the hopper to prevent sawdust build-up.

A combination of sawdust and pellets on the auger reduces the amount of fuel supply to the firepot. This can result in nuisance shutdowns and mis-starts.

- The appliance must be in complete shutdown. Allow the appliance to completely cool down.
- Empty the hopper of any remaining pellets.
- Vacuum the hopper and feed tube.

NOTE: Hearth & Home Technologies recommends to use a heavy duty vacuum cleaner specifically designed for solid fuel appliance cleaning.

11. Soot and Fly Ash: Formation & Need for Removal in Exhaust Venting System.

- **Frequency:** Yearly or more frequently depending on ash build-up.
- **By:** Qualified Service Technician/Homeowner

Be sure the appliance is allowed to cool, has been unplugged and the exhaust blower is off.

The products of combustion will contain small particles of fly ash. The fly ash will collect in the exhaust venting system and restrict the flow of the flue gases.

At start-up if there is incomplete combustion, or if there is a shutdown or incorrect operation of the appliance it will lead to some soot formation. This will collect in the exhaust venting system.

The venting (chimney) system may need to be cleaned at least once a year or more often depending upon the quality of your fuel or if there is a lot of horizontal pipe sections. Ash will build up more quickly in the horizontal sections.

12. Cleaning the Glass

- **Frequency:** When clear view of the firepot becomes obscure
- **By:** Homeowner
 - a. Appliance must be completely cool before cleaning glass.
 - b. Vacuum fly ash from glass and door rope.
 - c. Use a damp paper towel or any non-abrasive glass cleaner. Wipe off with dry towel.

13. Cleaning Exhaust Blower - Requires No Lubrication

- **Frequency:** Yearly or as needed
- **By:** Qualified Service Technician
- **Task:** Contact your local dealer

14. Cleaning Convection Blower - Requires No Lubrication

- **Frequency:** Yearly or every 25 bags or more frequently depending on operating environment
- **By:** Qualified Service Technician
- **Task:** Contact your local dealer.

15. Cleaning the Top Vent Adapter

- a. The appliance must be in complete shutdown and the exhaust blower should be off. Allow the appliance to completely cool down.
- b. Open the clean out cover. **Figure 15.1.**
- c. Sweep out any ash build-up.

NOTE: Hearth & Home Technologies recommends to use a heavy duty vacuum cleaner specifically designed for solid fuel appliance cleaning.

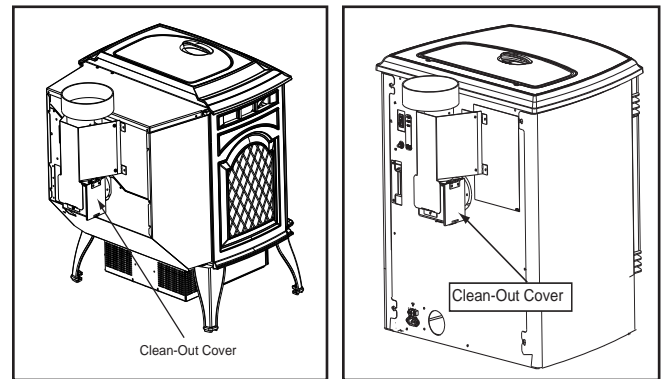
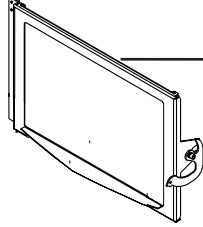

Figure 15.1

16. Preparing Firebox for Non-Burn Season

- **Frequency:** Yearly at the end of the heating season
- **By:** Homeowner
 - a. Be sure the appliance is allowed to cool, has been unplugged and the exhaust blower is off.
 - b. Remove all ash from the firebox and vacuum thoroughly.
 - c. Paint all exposed steel, including cast-iron.
 - Use the Touch-Up paint supplied with the appliance; or;
 - Purchase paint from your local dealer.
 - Must use a high-temperature paint made specifically for heating appliances.

CAUTION



Handle glass assembly with care.

When cleaning glass:

- Avoid striking, scratching or slamming glass.
- Do NOT clean glass when hot.

- Do NOT use abrasive cleaners.
- Refer to maintenance instructions.

WARNING

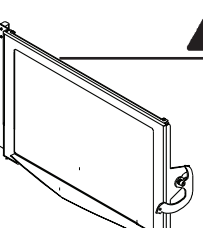

Handle glass with care.

- Inspect the gasket to ensure it is undamaged.
- Do NOT strike, slam or scratch glass.
- Do NOT operate appliance with glass assembly removed.

- Do NOT operate with glass cracked, broken or scratched.

D. High Ash Fuel Content Maintenance

- **Frequency:** As needed
- **By:** Homeowner

Poor quality pellet fuel, or lack of maintenance, can create conditions that make the firepot fill quickly with ashes and clinkers.

This condition makes the appliance susceptible to overflowing the firepot with pellets which may result in smoking, sooting and possible hopper fires. **Figure 16.1** shows an example where the firepot overfills, pellets back up into the feed tube and ash has accumulated in the firebox.

An inefficient and non-economical method of burning of fuel caused by poor quality pellet fuel is shown in **Figure 16.2**.

The correct flame size when good quality, premium pellet fuel is burned is shown in **Figure 16.3**.

If the ash buildup exceeds the half way point in the firepot **IMMEDIATE ATTENTION AND CLEANING IS REQUIRED.**

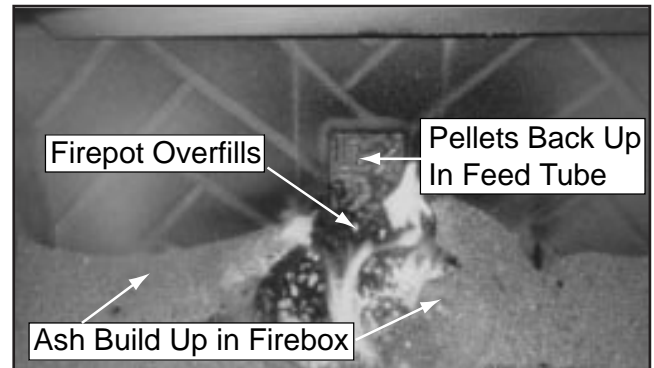

Figure 16.1

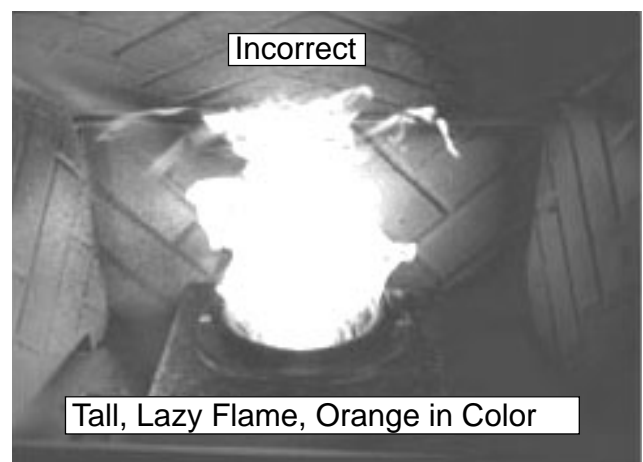



Figure 16.2

| | |
|--|--|
|  | <p>WARNING</p> |
| | <p>Fire Risk.</p> <ul style="list-style-type: none"> • High ash fuels, or lack of maintenance, can cause the firepot to overflow. Follow proper shutdown procedure if ash buildup exceeds half way point in firepot. • Failure to do so could result in smoking, sooting and possible hopper fires. |

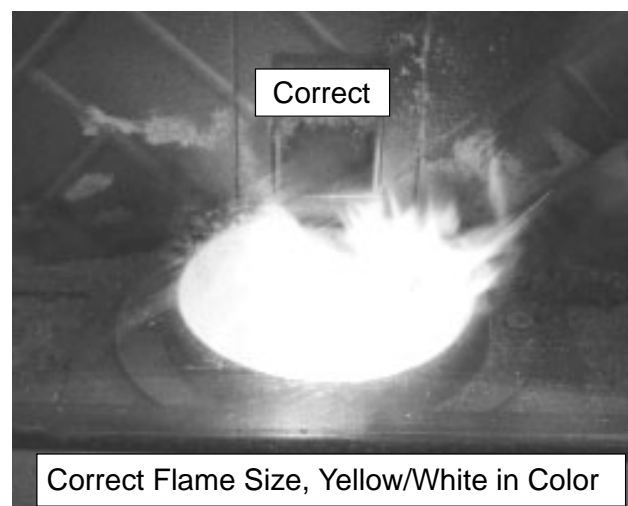

Figure 16.3

4 Troubleshooting for Homeowner

A. Frequently Asked Questions

| ISSUES | SOLUTIONS |
|--|---|
| 1. Metallic noise. | 1. Noise is caused by metal expanding and contracting as it heats up and cools down, similar to the sound produced by a furnace or heating duct. This noise does not affect the operation or longevity of your appliance. |
| 2. White ash buildup on glass. | 2. This is normal. Clean the glass using any non-abrasive glass cleaner. |
| 3. Glass has buildup of black soot | 3. Excessive build-up of ash. See solution #4. The lower burn settings will produce more ash, the higher burn settings produce less. The more it burns on low the more frequent cleaning of the glass is required. |
| 4. Glass has turned dirty. | 3. Excessive build up of ash. The lower burn settings will produce more ash, the higher burn settings produce less. The more it burns on low the more frequent cleaning of the glass is required. |
| 5. Fire has tall flames with black tails and is lazy. | 4. The feed rate needs to be reduced or the firepot needs cleaning. Heat exchanger or exhaust blower needs cleaning. |
| 6. Smokey start-up or puffs of smoke from the airwash. | 5. Either the firepot is dirty or there is too much fuel at start-up and not enough air. Close down feed rate 1/4 (6mm) inch at a time until this no longer happens. |
| 6. Large flame at start-up. | 6. This is normal. Flame will settle down once the fire is established. |

NOTICE: Odors and vapors are released during initial operation due to the curing of high temperature paint. Open windows for air circulation. Odors may be irritating to sensitive individuals.

Installer's Guide

5 Getting Started

A. Design, Installation & Location Considerations

1. Appliance Location

NOTICE: Check building codes prior to installation.

- Installation MUST comply with all local building codes and regulations including those referring to national and European standards.
- Consult insurance carrier, local building inspector, fire officials or authorities having jurisdiction over restrictions, installation inspection and permits.

It is a good idea to plan your installation on paper, using exact measurements for clearances and floor protection, before actually beginning the installation. Location of the appliance and chimney will affect performance.

Consideration must be given to:

- Safety, convenience, traffic flow
- Placement of the chimney and chimney connector and to minimize the use of chimney offsets.
- Place the appliance where there will be a clear passage for a Listed chimney through the ceiling and roof (vertical) or through exterior wall (horizontal).
- Installing the required outside air kit will affect the location of the vent termination.

Since pellet exhaust can contain ash, soot or sparks, you must consider the location of:

- Windows
- Air Intakes
- Air Conditioner
- Overhang, soffits, porch roofs, adjacent walls
- Landscaping, vegetation
- Horizontal or vertical vent termination

When locating vent and venting termination, the ideal location is to vent above roof line when possible. This minimizes the affects of wind loading.

2. Floor Support

The supporting floor under the appliance must be able to handle the weight of the appliance, fuel load and the weight of the chimney.

Ensure that your floor will support these weights prior to installation. Add sufficient additional support to meet this weight requirement prior to installation. The weight of this appliance is 109 kg and with a full hopper of fuel weighing 18 kg, the total for the appliance and fuel is 137 kg.

WARNING! Risk of Fire Damaged parts could impair safe operation. Do NOT install damaged, incomplete or substitute components.

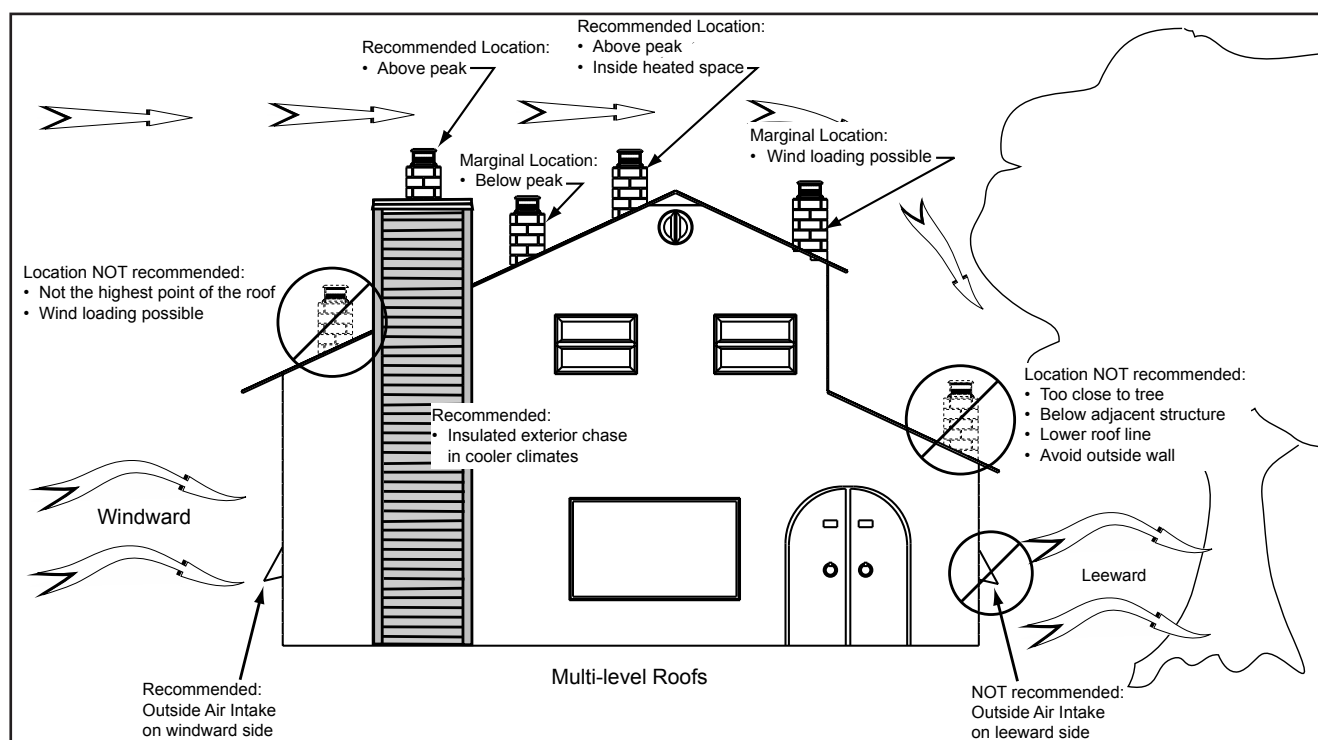

Figure 18.1

B. Thermostat Location

The thermostat’s location will have some effect on the appliance’s operation.

When the thermostat is located close to the appliance, it may require a slightly higher temperature setting to keep the rest of the house comfortable.

If the thermostat location is in an adjacent room or on a different floor level, you will notice higher temperatures near the appliance.

C. Tools And Supplies Needed

| | |
|--|--|
| Tools and building supplies normally required for installation. | |
| Reciprocating Saw | 7/16 inch Socket Wrench |
| Hammer | (or 10mm 6 pt or 11mm 6 pt socket) |
| Phillips Screwdriver | 7/16 inch Socket Wrench |
| Tape Measure | Framing Square |
| Plumb Line | Electric Drill & Bits |
| Level | Self-Tapping Screws |
| Framing Material | Outside Air Required |
| Hi-temp Caulking Material | Class L or PL Pellet Vent |
| Gloves | |
| Safety Glasses | <u>May also need:</u> Vent Support Straps |

D. Inspect Appliance and Components

WARNING! Risk of Fire! Damaged parts could impair safe operation. Do NOT install damaged, incomplete or substitute components.

- Open the appliance and remove all the parts and articles packed inside the Component Pack. Inspect all the parts and glass for shipping damage.
- Report to your dealer any parts damaged in shipment.
- All labels have been removed from the glass door.
- Plated surfaces have been wiped clean with a soft cloth, if applicable.
- **Read all the instructions before starting the installation. Follow these instructions carefully during the installation to ensure maximum safety and benefit.**
- **Follow pipe manufacturer instructions for installation and air clearance requirements.**

E. Pre-Burn Check List

| | | |
|-----|--|--|
| 1. | | Place the appliance in a location near the final installation area and follow the procedures below: |
| 2. | | Open the appliance and remove all the parts and articles packed inside the Component Pack. Inspect all the parts and glass for shipping damage. Contact your dealer if any irregularities are noticed. |
| 3. | | All safety warnings have been read and followed. |
| 4. | | This Owner’s Manual has been read. |
| 5. | | Floor protection requirements have been met. |
| 6. | | Venting is properly installed. |
| 7. | | The proper clearances from the appliance and chimney to combustible materials have been met. |
| 8. | | The masonry chimney is inspected by a professional and is clean, or the factory built metal chimney is installed according to the manufacturer’s instructions and clearances. |
| 9. | | The chimney meets the required minimum height. |
| 10. | | All labels have been removed from the glass door. |
| 11. | | Plated surfaces have been wiped clean, if applicable. |
| 12. | | Thermostat or remote has been installed. |
| 13. | | A power outlet is available nearby. |

6 Dimensions and Clearances

A. Appliance Dimensions

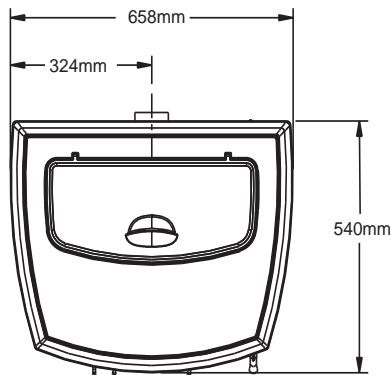

Figure 20.1 - Top View

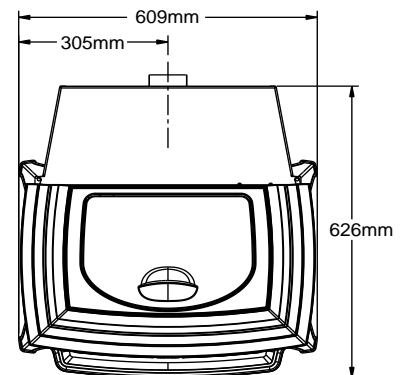

Figure 20.5 - Top View

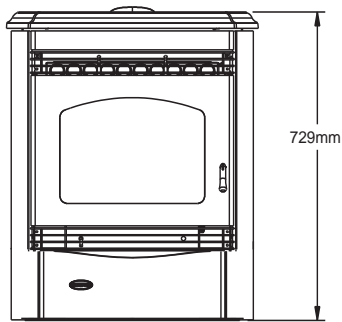

Figure 20.2- Front View

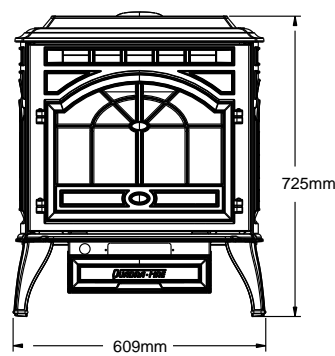

Figure 20.6- Front View

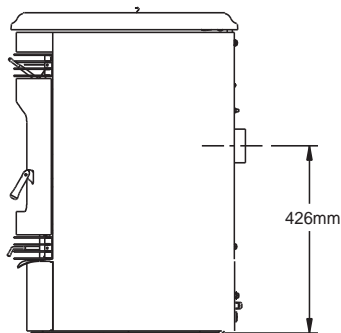

Figure 20.3 -Side View

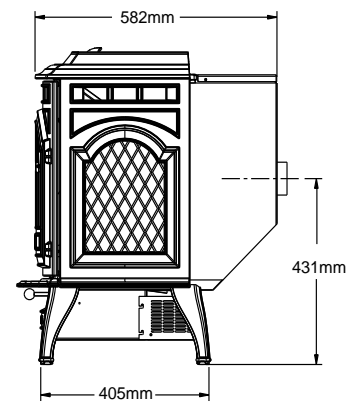

Figure 20.7 -Side View

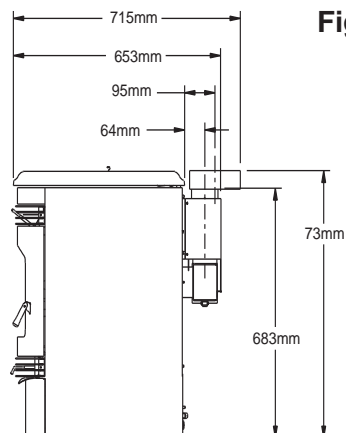

Figure 20.4 - Side View with Top Vent Adapter

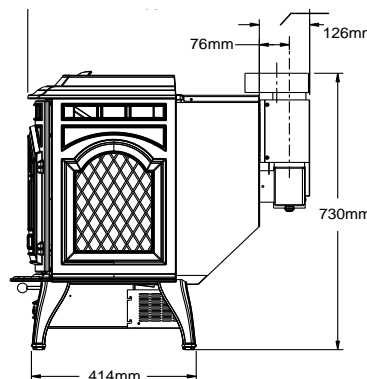
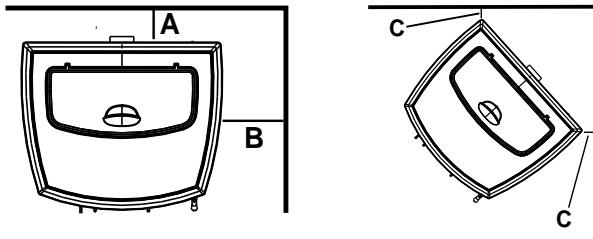

Figure 20.8 - Side View with Top Vent Adapter

B. Clearances to Combustibles



| Straight Back Against Wall | | Millimeters |
|----------------------------|------------------------|-------------|
| A | Back Wall to Appliance | 50 |
| B | Side Wall to Appliance | 160 |

| Corner Installation | | Millimeters |
|---------------------|--------------------|-------------|
| C | Walls to Appliance | 50 |

| Alcove Installation | | Millimeters |
|--------------------------|--|-------------|
| Minimum Alcove Height | | 1092 |
| Minimum Alcove Side Wall | | 152 |
| Minimum Alcove Width | | 965 |
| Maximum Alcove Depth | | 914 |

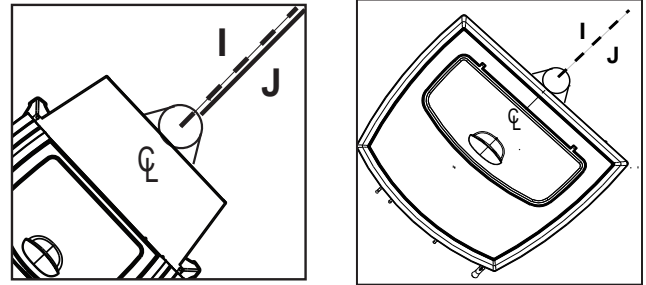

| Dimension to Corner | | Millimeters |
|---------------------|--------------------------------------|-------------|
| I | Flue Center Line (Santa Fe/ Castile) | 217 / 264 |
| J | Back of Top Vent Adapter | 232 |

**Installations with:
76mm to 76mm Top Vent Adapter and
76mm to 152mm Offset Adapter**

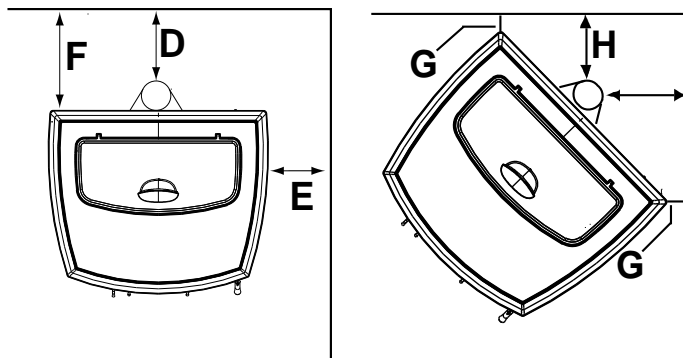

| Vertical Installation | | Millimeters |
|-----------------------|------------------------|-------------|
| D | Back Wall to Flue Pipe | 76 |
| E | Side Wall to Cast Top | 152 |
| F | Back Wall to Appliance | 178 |

| Corner Installation | | Millimeters |
|---------------------|------------------------|-------------|
| G | Walls to Appliance | 50 |
| H | Side Wall to Flue Pipe | 76 |

WARNING

Fire Risk.
Comply with all minimum clearances to combustibles as specified.

Failure to comply may cause house fire.

NOTE:

- Illustrations reflect typical installations and are FOR DESIGN PURPOSES ONLY.
- Illustrations/diagrams are not drawn to scale.
- Actual installation may vary due to individual design preference.

C. Hearth Pad Requirements

If the current flooring is made from wood, provide adequate surface protection according to the current national standards..

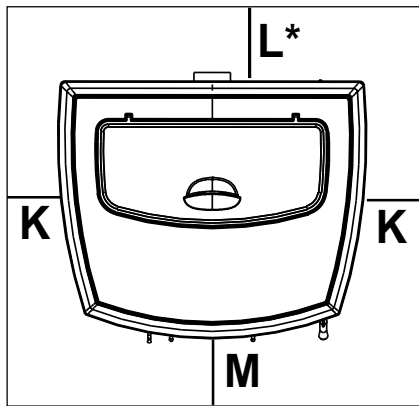

Figure 22.1

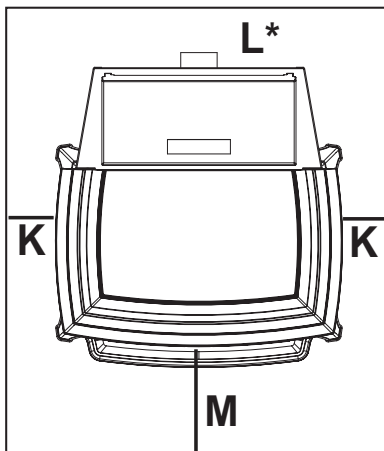
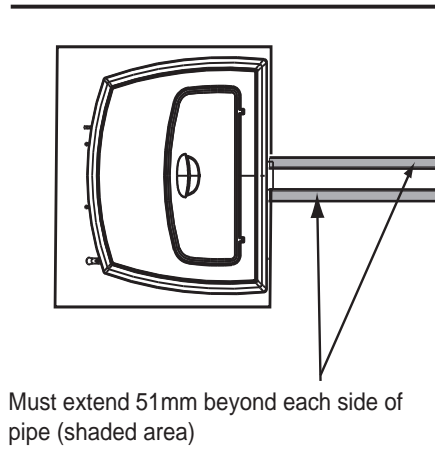
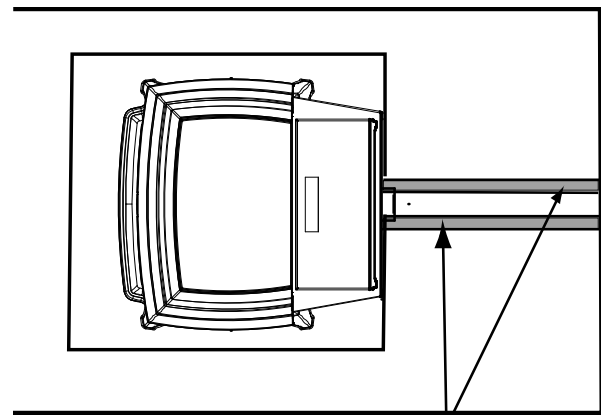

Figure 22.2



Must extend 51 mm beyond each side of pipe (shaded area)

Figure 22.3



Must extend 2 inches (51mm) beyond each side of pipe (shaded area)

Figure 22.4

Recommended Hearth Pad Requirements

| Hearth Pad Requirements | | Millimeters |
|-------------------------|-------|-------------|
| K | Sides | 50 |
| L* | Back | 50 |
| M | Front | 152 |

Exception for Horizontal Installations:

A non-combustible floor protection extending beneath the flue pipe is **required** with horizontal venting or under the top vent adapter with vertical installation. **Figure 22.3 & Figure 22.4.**

7 Vent Information

A. Venting Termination Requirements

CAUTION

Do not terminate vent in any enclosed or semi-enclosed area such as a carport, garage, attic, crawl space, under a sun deck or porch, narrow walkway or closely fenced area, or any location that can build up a concentration of fumes such as a stairwell, covered breezeway, etc.

1. Termination must exhaust above air inlet elevation. **It is strongly recommended that at least 1.5m of vertical pipe be installed when appliance is vented directly through a wall.** This will create a natural draft, which will help prevent the possibility of smoke or odor venting into the home during a power outage. It will also keep exhaust from causing a nuisance or hazard by exposing people or shrubs to high temperatures. The safest and preferred venting method is to extend the vent vertically through the roof.
2. Distance from doors and opening windows, or gravity or ventilation air inlets into building:
 - a. Not less than 1.2m below;
 - b. Not less than 1.2m horizontally from;
 - c. Not less than 305mm above.
3. Distance from permanently closed windows;
 - a. Not less than 305mm below; horizontally from or above.
4. Distance between bottom of termination and grade should be 305mm minimum. This is conditional upon plants in the area, and nature of grade surface. The grade surface must be a non-combustible material (i.e., rock, dirt). The grade surface must not be lawn. Distance between bottom of termination and public walkway should be 2.13m minimum.
5. Distance to combustible materials must be 610mm minimum. This includes adjacent buildings, fences, protruding parts of the structure, roof overhang, plants and shrubs, etc.
6. Termination Cap Location (Home Electrical Service)
 - Side-to-side clearance is to be the same as minimum clearance to vinyl inside corners.
 - Clearance of a termination cap below electrical service shall be the same as minimum clearance to vinyl soffits.
 - Clearance of a termination cap above electrical service will be 305mm minimum.
 - Location of the vent termination must not obstruct or interfere with access to the electrical service.

B. Avoiding Smoke and Odors

Negative Pressure, Shut-Down and Electrical Power Failure

To reduce the probability of back-drafting or burn-back in the pellet appliance during power failure or shut down conditions, it must be able to draft naturally without exhaust blower operation.

Negative pressure in the house will resist this natural draft if not accounted for in the pellet appliance installation.

Heat rises in the house and leaks out at upper levels. This air must be replaced with cold air from outdoors which flows into lower levels of the house.

Vents and chimneys into basements and lower levels of the house can become the conduit for air supply and reverse under these conditions.

Outside Air

An outside air kit is recommended in all installations. The Outside Air Kit must be ordered separately.

Per your local building codes, consideration must be given to combustion air supply to all combustion appliances. Failure to supply adequate combustion air for all appliance demands may lead to backdrafting of those and other appliances.

When the appliance is roof vented (strongly recommended):

The air intake is best located on the exterior wall oriented towards the prevailing wind direction during the heating season.

When the appliance is side-wall vented:

The air intake is best located on the same exterior wall as the exhaust vent outlet and located lower on the wall than the exhaust vent outlet.

The outside air supply kit can supply most of the demands of the pellet appliance, but consideration must be given to the total house demand.

House demand may consume the air needed for the appliance. It may be necessary to add additional ventilation to the space in which the pellet appliance is located.

Consult with your local heating professional to determine the ventilation demands for your house.

Vent Configurations

To reduce probability of reverse drafting during shut-down conditions Hearth & Home Technologies strongly recommends:

- Installing the pellet vent with a minimum vertical run of 1.52m. Preferably terminating above the roof line.
- Installing the outside air kit at least 1.22m below the vent termination.

To prevent soot damage to exterior walls of the house and to prevent re-entry of soot or ash into the house:

- Maintain specified clearances to windows, doors and air inlets, including air conditioners.
- Vents should not be placed below ventilated soffits. Run the vent above the roof.
- Avoid venting into alcove locations.
- Vents should not terminate under overhangs, decks or onto covered porches.
- Maintain minimum clearance of 152mm from the vent termination to the exterior wall. If you see deposits developing on the wall, you may need to extend this distance to accommodate your installation conditions.

C. Negative Pressure

WARNING! Risk of Asphyxiation! Negative pressure can cause spillage of combustion fumes and soot.

Negative pressure results from the imbalance of air available for the appliance to operate properly. It can be strongest in lower levels of the house.

Causes include:

- Exhaust fans (kitchen, bath, etc.)
- Range hoods
- Combustion air requirements for furnaces, water heaters and other combustion appliances
- Clothes dryers
- Location of return-air vents to furnace or air conditioning
- Imbalances of the heating/cooling air handling system
- Upper level air leaks such as:
 - Recessed lighting
 - Attic hatch
 - Duct leaks

To minimize the effects of negative air pressure:

- Install the outside air kit with the intake facing prevailing winds during the heating season
- Ensure adequate outdoor air for all combustion appliances and exhaust equipment
- Ensure furnace and air conditioning return vents are not located in the immediate vicinity of the appliance
- Avoid installing the appliance near doors, walkways or small isolated spaces
- Recessed lighting should be a “sealed can” design
- Attic hatches weather stripped or sealed
- Attic mounted duct work and air handler joints and seams taped or sealed

On nominal heat output the combustion blower operates at 2053 rpm developing 0.33 m³/s. This is the minimum requirement for the supply of combustion air.

D. Draft

Draft is the pressure difference needed to vent appliances successfully. When an appliance is drafting successfully, all combustion byproducts are exiting the home through the chimney.

Install through the warm airspace enclosed by the building envelope. This helps to produce more draft, especially during lighting and die-down of the fire.

Considerations for successful draft include:

- Preventing negative pressure
- Location of appliance and chimney

To measure the draft or negative pressure on your appliance use a manahelic or a digital pressure gauge capable of reading 0 - .13mm of water column (W.C.).

The appliance should be running on high for at least 15 minutes for the test.

With the stove running on high you should have a negative pressure equal to or greater than the number given in the chart below. If you have a lower reading than you find on the chart, your appliance does not have adequate draft to burn the fuel properly.

| | |
|-------------------------------------|-------------|
| Minimum Vacuum Requirements: | .095 |
|-------------------------------------|-------------|

NOTICE: Hearth & Home Technologies assumes no responsibility for the improper performance of the chimney system caused by:

- Inadequate draft due to environmental conditions
- Downdrafts
- Tight sealing construction of the structure
- Mechanical exhausting devices

E. Chimney and Exhaust Connection

1. **Chimney & Connector:** Use 76mm to 102mm diameter type "L" or "PL" venting system. It can be vented vertically or horizontally.
2. **Residential:** The 76mm vertical Top Vent Adapter Kit and the 76mm to 152mm Top Vent Offset Adapter are tested to use 24 gauge single wall flue connector or Listed double wall flue connector to Class A Listed metal chimneys, or masonry chimneys meeting International Conference of Building Officials (ICBO) standards for solid fuel appliances.
3. **INSTALL VENT AT CLEARANCES SPECIFIED BY THE VENT MANUFACTURER.**
4. **Exhaust Venting System:** Secure to the appliance with at least 2 screws 180 degrees apart. Also secure all connector pipe joints with at least 3 screws through each joint.
5. **DO NOT INSTALL A FLUE DAMPER IN THE EXHAUST VENTING SYSTEM OF THIS UNIT.**
6. **DO NOT CONNECT THIS UNIT TO A CHIMNEY FLUE SERVING ANOTHER APPLIANCE.**

NOTE: All pipe must be welded seam pipe whenever possible. Seal pipe joints with high temperature silicone (260°C) minimum rated only. Do not put silicone inside of pipe.

**CAUTION**

- DO NOT CONNECT THIS UNIT TO A CHIMNEY FLUE SERVING ANOTHER APPLIANCE.
- DO NOT CONNECT TO ANY AIR DISTRIBUTION DUCT OR SYSTEM.

May allow flue gases to enter the house

**WARNING**

vent surfaces get HOT, can cause burns if touched. Non-combustible shielding or guards may be required.

**WARNING****Fire Risk.**

Follow Chimney Connector Manufacturer's Instructions for Proper Installation.

ONLY use connector:

- Within the room, between appliance and ceiling or wall.

Connector shall NOT pass through:

- Attic or roof space
- Closet or similar concealed space
- Floor or ceiling

Maintain minimum clearances to combustibles

C. Pellet Venting Charts

The maximum horizontal venting allowed with no vertical venting attached is 219mm including one 90° elbow or two 45° elbows. This is our recommended horizontal venting installation. Addition of any horizontal venting beyond 1219mm Hearth & Home Technologies strong recommends a minimum of 1524mm of additional vertical vent. Horizontal sections of vent pipe should have a 6.35mm rise per foot.

Hearth & Home Technologies recommends any installation requiring more than two 90° elbows, or more than 4.5m of venting to use 102mm vent.



WARNING

Fire Risk.

- Only LISTED venting components may be used.
- NO OTHER vent components may be used. Substitute or damaged vent components may impair safe operation.

45° elbow is equivalent to 30.48cm of straight pipe
 90° elbow is equivalent to 91.44cm of straight pipe

| ONE 90° ELBOW | | |
|------------------|------------------|---------------|
| Total Horizontal | Minimum Vertical | Vent Diameter |
| 4 | 0 | 3 |
| 5 | 5 | 3 |
| 6 | 6 | 3 |
| 7 | 7 | 3 |
| 8 | 8 | 4 |
| 9 | 9 | 4 |
| 10 | 10 | 4 |
| 11 | 11 | 4 |
| 12 | 12 | 4 |
| 13 | 13 | 4 |
| 14 | 14 | 4 |
| 15 | 15 | 4 |
| 16 | 16 | 4 |
| 17 | 17 | 4 |
| 18 | 18 | 4 |
| 19 | 19 | 4 |

| TWO 90° ELBOWS | | |
|------------------|------------------|---------------|
| Total Horizontal | Minimum Vertical | Vent Diameter |
| 2 | 5 | 3 |
| 3 | 6 | 3 |
| 4 | 7 | 3 |
| 5 | 8 | 3 |
| 6 | 9 | 3 |
| 7 | 10 | 4 |
| 8 | 11 | 4 |
| 9 | 12 | 4 |
| 10 | 13 | 4 |
| 11 | 14 | 4 |
| 12 | 15 | 4 |
| 13 | 16 | 4 |
| 14 | 17 | 4 |
| 15 | 18 | 4 |

| THREE 90° ELBOWS | | |
|------------------|------------------|---------------|
| Total Horizontal | Minimum Vertical | Vent Diameter |
| 2 | 11 | 4 |
| 3 | 12 | 4 |
| 4 | 13 | 4 |
| 5 | 14 | 4 |
| 6 | 15 | 4 |
| 7 | 16 | 4 |
| 8 | 17 | 4 |
| 9 | 18 | 4 |
| 10 | 19 | 4 |
| 11 | 20 | 4 |

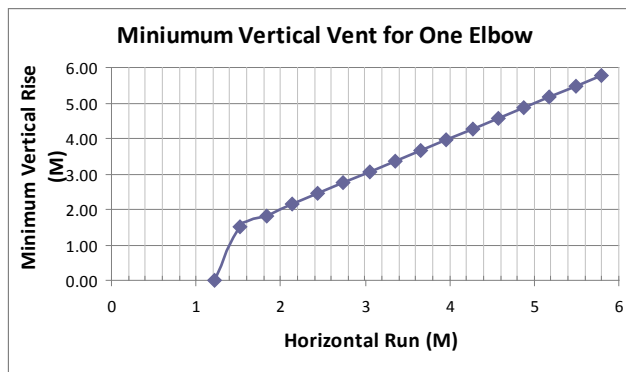

Figure 26.1

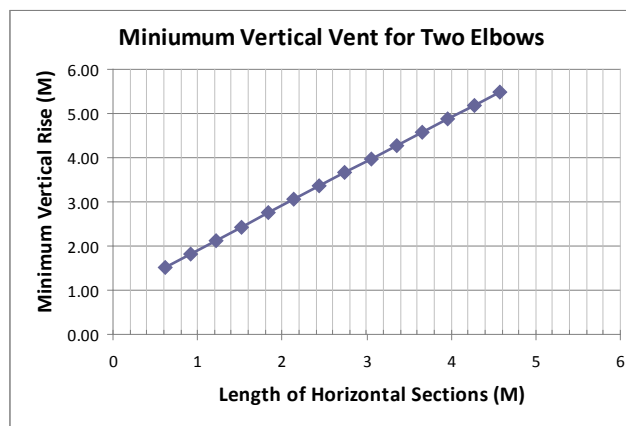

Figure 26.2

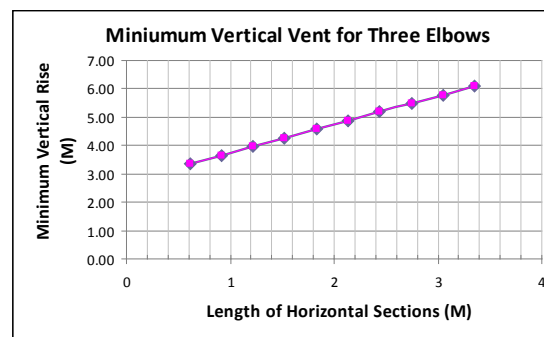

Figure 26.3

NOTICE: These are guidelines for successful venting of your pellet appliance. The more vertical rise you can obtain in your system, the better it will perform. Horizontal vent runs can accumulate ash and will need to be cleaned more often. Try to keep them as short as possible.

8 Venting Systems

A. Alcove

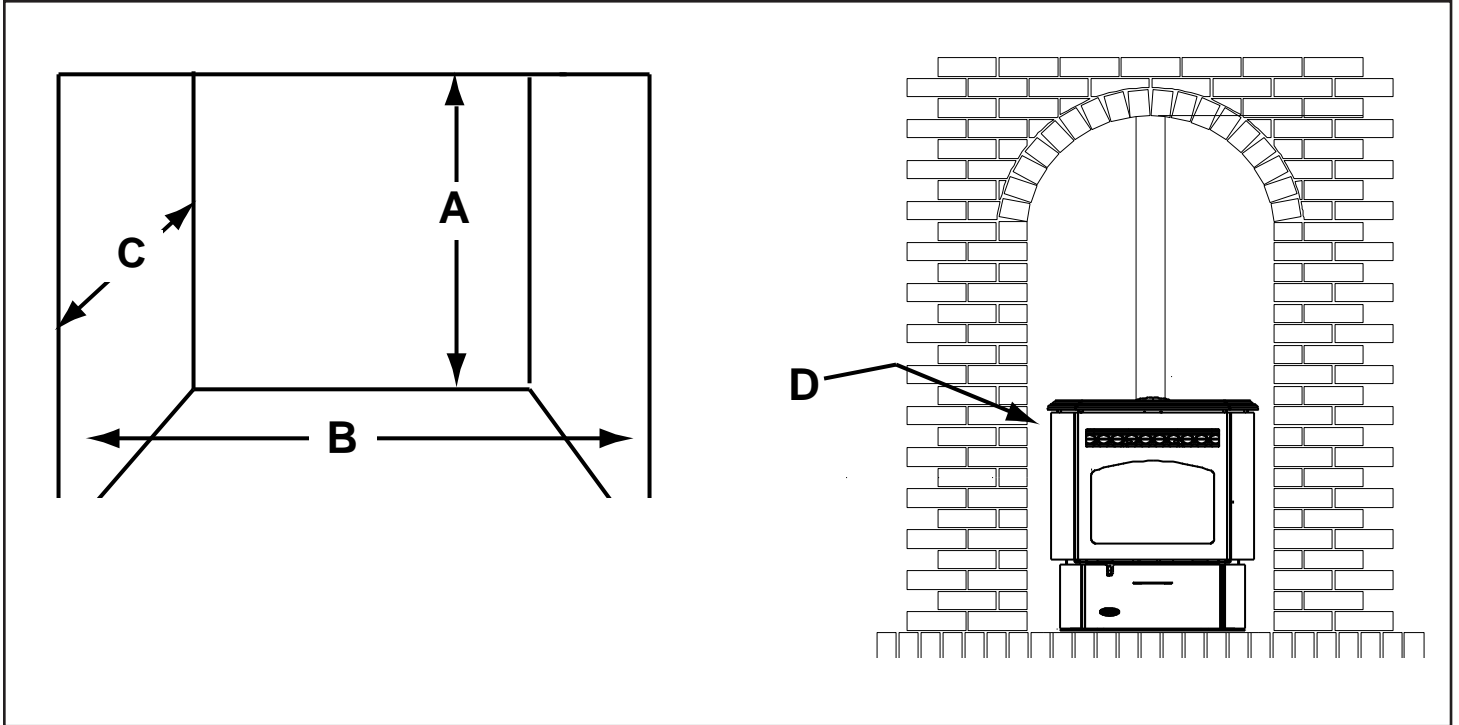

Figure 27.1

| | | Minimum | Maximum |
|----------|--------------|-------------|-------------|
| | | Millimeters | Millimeters |
| A | Height | 1092 | n/a |
| B | Width | 965 | n/a |
| C | Depth | n/a | 914 |
| D | To Side Wall | 152 | n/a |

All minimums listed are to a combustible surface.

NOTE:

- Illustrations reflect typical installations and are FOR DESIGN PURPOSES ONLY.
- Illustrations/diagrams are not drawn to scale.
- Actual installation may vary due to individual design preference.

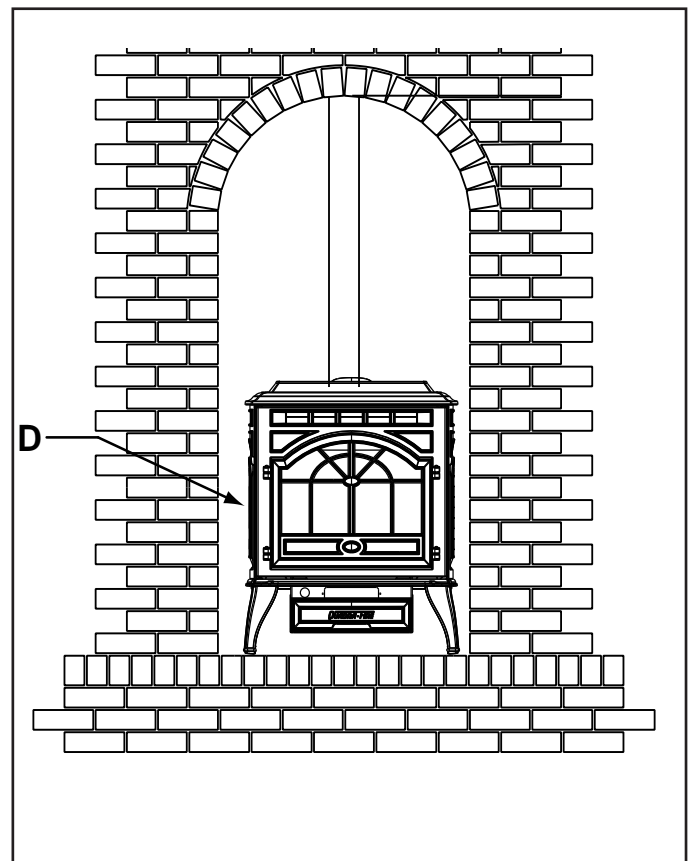

**B. Vertical - Interior - Typical Installation
(SHOWN ON A SANTA FE)**

PREFERRED METHOD #1

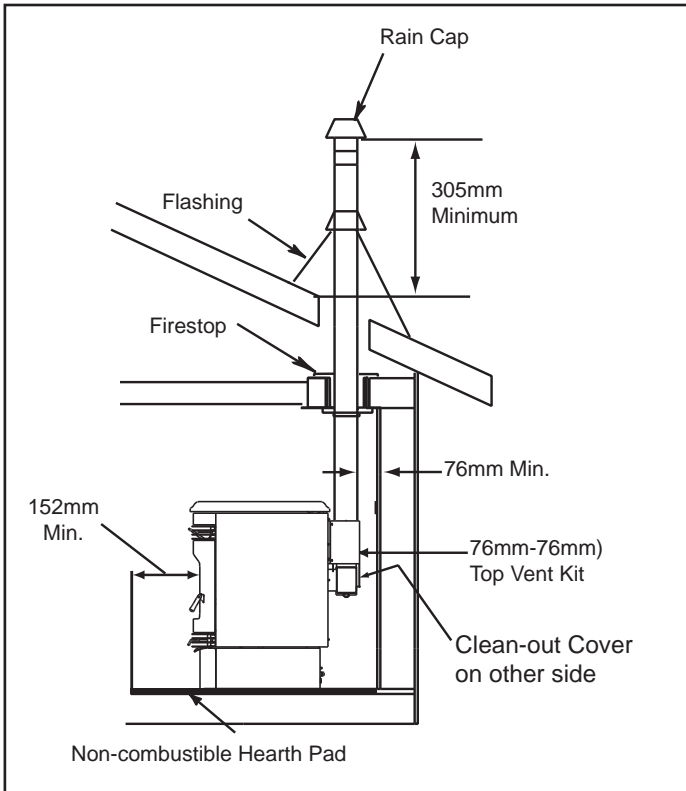

Figure 28.1

**C. Through The Wall & Vertical - External
(SHOWN ON A SANTA FE)**

PREFERRED METHOD #2

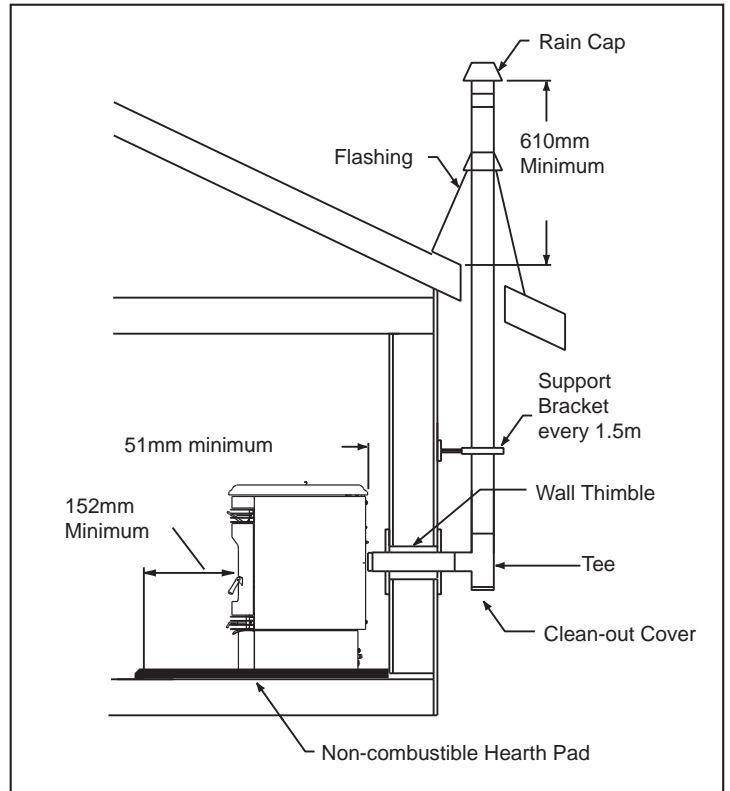

Figure 28.2

**D. Vertical into Existing Chimney
(SHOWN ON A SANTA FE)**

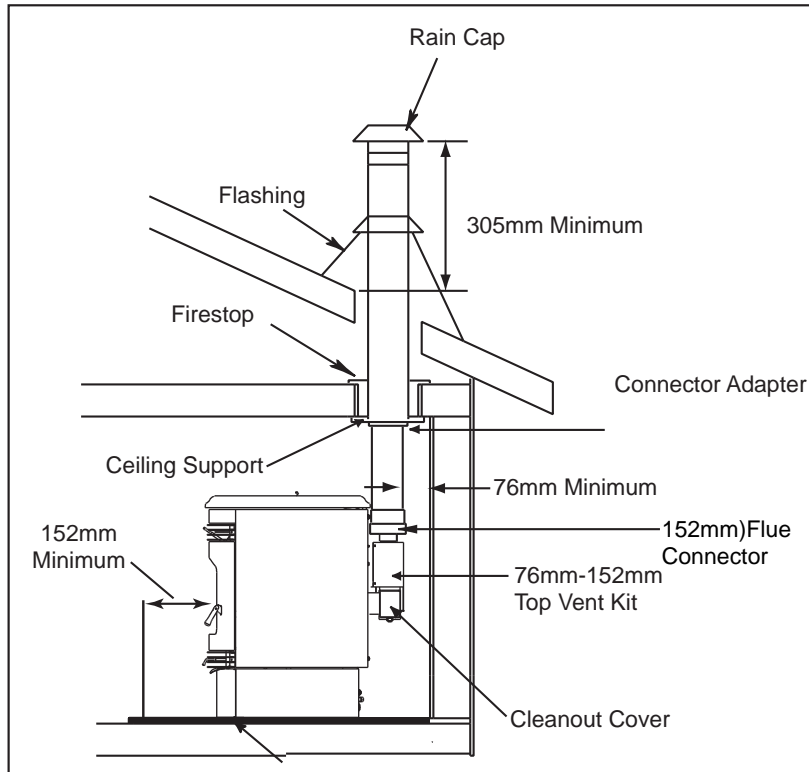

Figure 28.3

We strongly recommend a minimum of 1.5m vertical, however above the eave is preferred.

Both installations are approved for mobile home installations. Must use 76mm to 102mm "L" or "PL" Listed pellet venting or Listed double wall pipe and Quadra-Fire Outside Air Kit in mobile homes. Single wall pipe is approved for residential installations only.

Air Clearance to Pipe:

This appliance was tested with standard 76mm Listed pellet clearance pipe to combustibles.

Pellet pipe manufactures Listed reduce clearance pipe may be use for reduce clearance from 76mm air clearance to no less than 25mm air clearance to combustibles for approved Listed pellet pipe.

Follow stove pipe manufactures listed air clearances to combustibles and installation instructions for all reduced air clearances installations.

The stove must be connected to a flue pipe conforming to current standards UNI 7129-7131 9615.

 **WARNING**

 **Fire Risk**
Inspection of Chimney:
• Masonry chimney must be in good condition.

**E. Masonry
(SHOWN ON A
SANTA FE)**

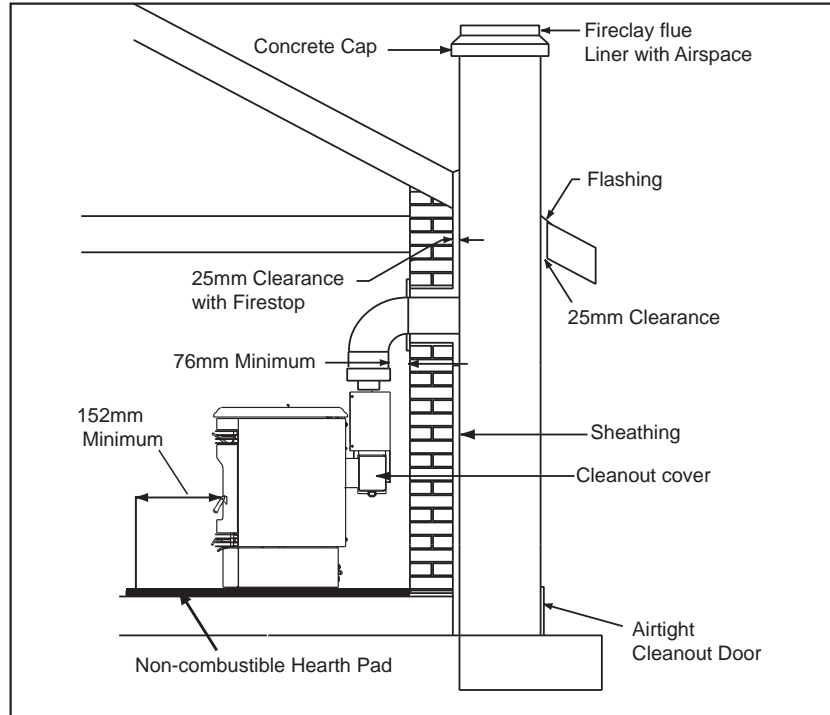

Figure 29.1

**F. Alternate Masonry
(SHOWN ON A
SANTA FE)**

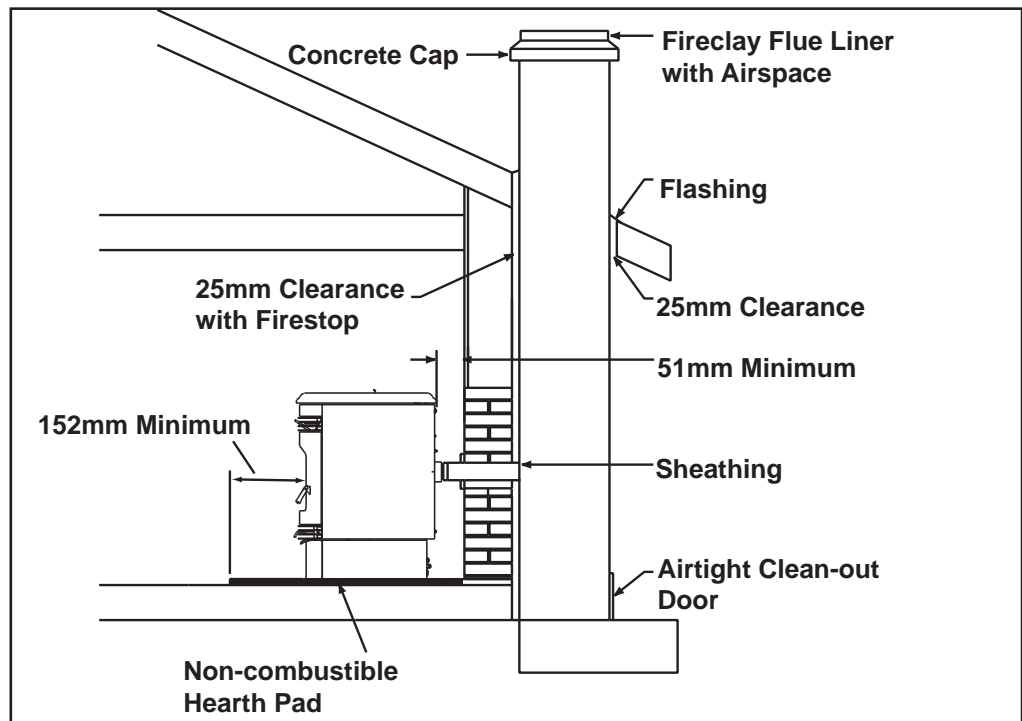

Figure 29.2

G. Through The Wall

Horizontal termination cap must be a minimum of 152mm from the wall. Approved for mobile home installations. Must use 76mm to 102mm "L" or "PL" listed pellet venting or listed double wall pipe and a Quadra-Fire Outside Air Kit in mobile homes.

NOTICE:

Please note that while the minimum clearance for the termination cap is 152mm there is the possibility of soot build-up around the termination area. If this occurs we suggest to move the termination further away from the house to prevent it.

CAUTION

We strongly recommend that you **DO NOT** DOWNWARD VENT.

The following may occur:

- The appliance will not vent properly
- Smoke spillage in the house
- Excessive sooting

Straight Out

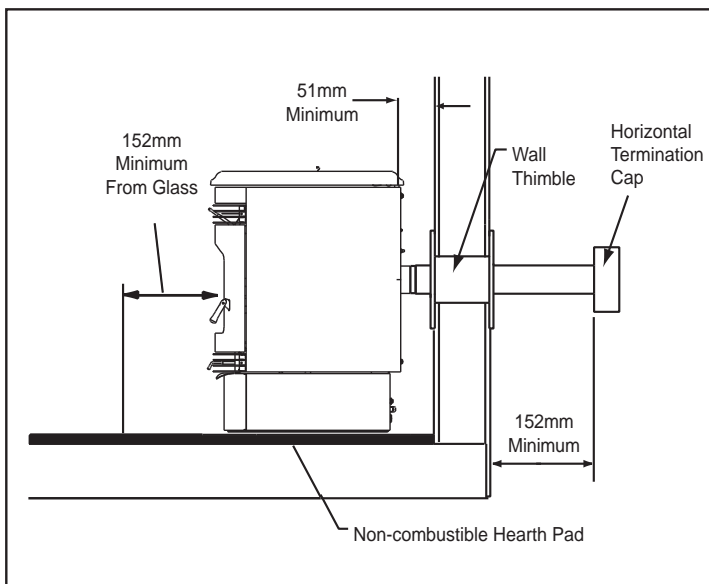

Figure 30.1

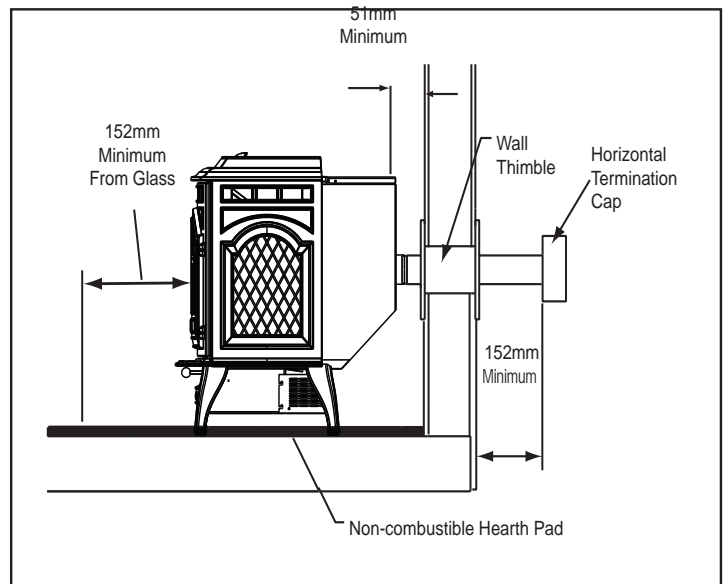

Figure 30.2

45 Degree

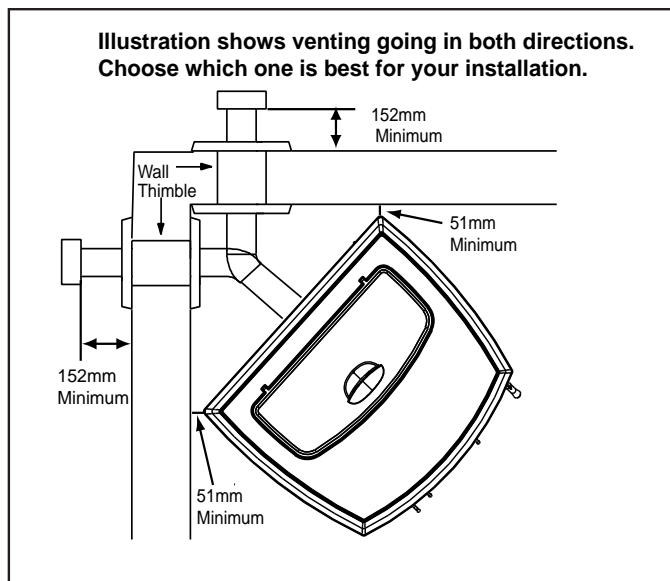

Figure 30.3

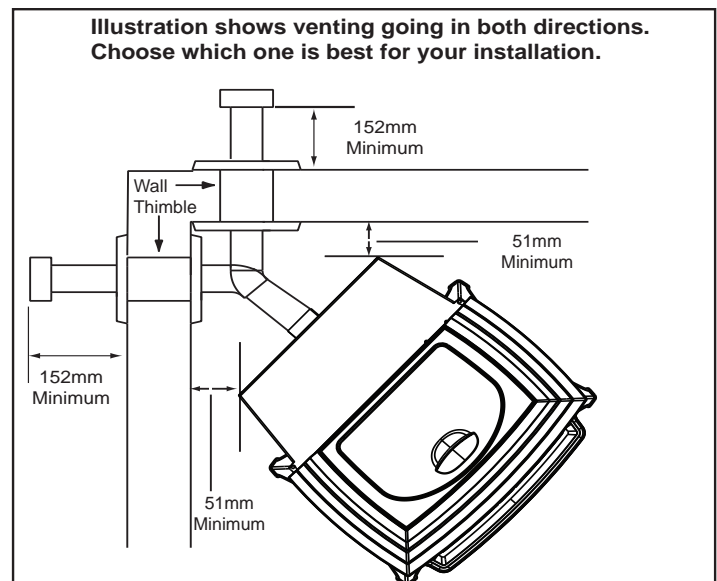

Figure 30.4

9 Appliance Set-Up

A. Outside Air Kit Instructions (Shown on SANTA FE)

Parts Included in Kit: 1 piece of 51mm x 914.4mm flex hose, 2 hose clamps, 1 air intake channel collar assembly, 1 termination cap assembly, 1 trim ring, 12 screws. (Discard air channel if it is not need for this appliance).

Tools Needed: Phillips head screwdriver; wire cutters; hole saw or jig saw.

1. Measure distance from floor to air vent opening in stove and mark location on wall.
Use saw to cut opening in wall. Cut a 64 to 76mm opening on inside wall and a 76 to 89mm opening on outside of house.
2. Remove cover plate and then install the collar assembly.
3. Use hose clamp to secure flex pipe to collar assembly.
4. Slide trim ring over flex pipe and run pipe through wall.
5. Attach hose to outside termination cap with second hose clamp.
6. Secure termination cap to outside surface.
7. Secure trim ring to interior wall.

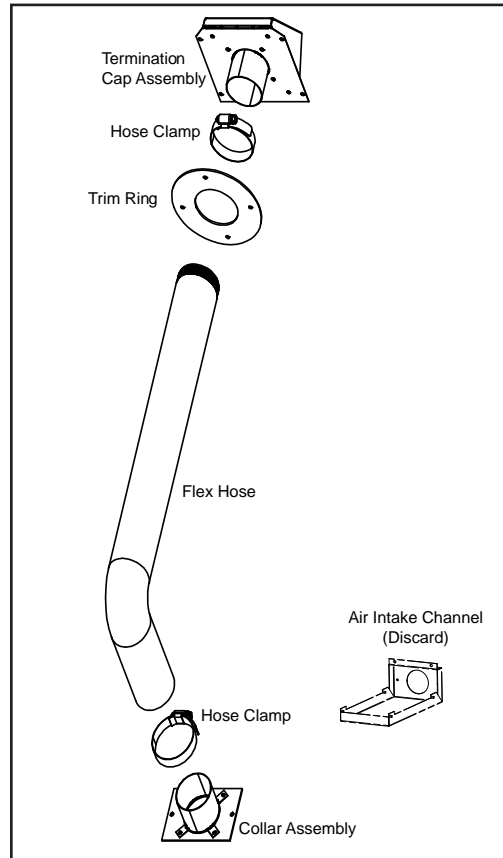

Figure 32.2

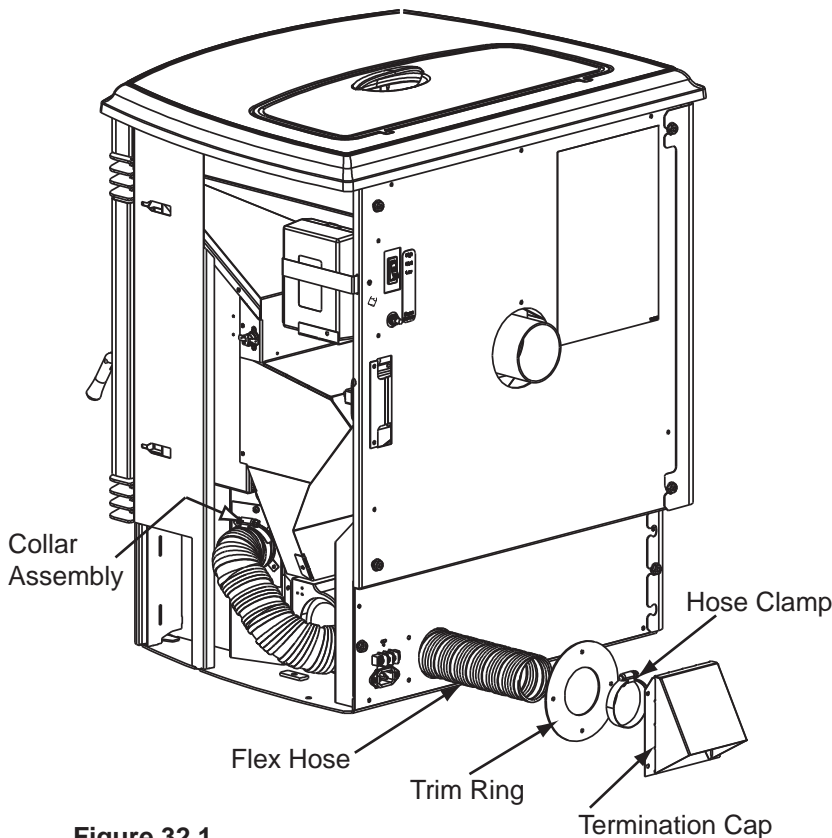

Figure 32.1

| |
|---|
| CAUTION |
| <p>Never draw outside combustion air from:</p> <ul style="list-style-type: none"> • Wall, floor or ceiling cavity • Enclosed space such as an attic or garage |

B. Optional Log Set Placement Instructions

CAUTION

Logs are FRAGILE. Use extreme care when handling or cleaning logs.

NOTE:

Due to the abrasive nature of a pellet appliance fire, the logs are not covered under warranty. Any placement variation other than shown here can cause excessive heat and shall void the appliance warranty.

Two Piece Log Set Installation

1. Open door to expose the firebox.
2. Install the left log first and then the right log. **Figure 33.1**
3. Lean the logs against the cast iron brick in the back of the firebox.
4. Push the logs to the far left and far right against the sides of the firebox. **Figure 33.2.**
5. To clean the logs, use a vacuum and a soft brush attachment or a paint brush.



Figure 33.1

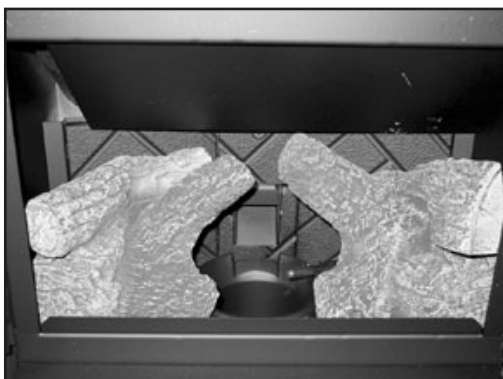

Figure 33.2

C. Thermostat Installation

1. A 12 volt AC thermostat is required to operate this pellet appliance. You may use the included wall mount thermostat or purchase an optional programmable thermostat or remote control. It is equipped with an adjustable heat anticipator. The current rating is .05 amps. The anticipator needs to be adjusted to the lowest setting available.

2. When mounting a thermostat on a wall, be sure to follow your thermostat installation instructions carefully.

NOTE: Thermostat must be mounted level for accurate readings. The thermostat should be mounted on an inside wall and not in direct line with the appliance convection air.

NOTE: If the thermostat is located too close to the appliance, you may need to set the temperature setting slightly higher to maintain the desired temperature in your home.

3. There is a 4 screw terminal block located on the back lower left corner of the stove directly above the power cord inlet. The center 2 screws are for the thermostat wires.

CAUTION

Shock hazard.

- Do NOT remove grounding prong from plug.
- Plug directly into properly grounded 3 prong receptacle.
- Route cord away from appliance.
- Do NOT route cord under or in front of appliance.

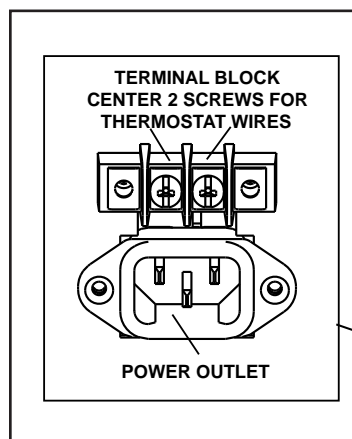

Figure 33.3

QUADRA-FIRE®

CONTACT INFORMATION:

Hearth & Home Technologies
1445 North Highway
Colville, WA 99114
Division of HNI Corporation

Please contact your Quadra-Fire dealer with any questions or concerns.
For the number of your nearest Quadra-Fire dealer
logo onto www.quadrafire.com

CAUTION



DO NOT DISCARD THIS MANUAL

- Important operating and maintenance instructions included.
- Read, understand and follow these instructions for safe installation and operation.
- Leave this manual with party responsible for use and operation.



We recommend that you record the following pertinent information for your **CASTILE** or **SANTA FE CE PELLET STOVE**

Date purchased/installed: _____

Serial Number: _____ Location on appliance: _____

Dealership purchased from: _____ Dealer phone: _____

Notes: _____

This product may be covered by one or more of the following patents: (United States) 6830000 and 5582117 or other U.S. and foreign patents pending.

