

Owner's Manual

Operation & Care

INSTALLER: Leave this manual with party responsible for use and operation.
OWNER: Retain this manual for future reference.

Contact your dealer with question on installation, operation, or service.

NOTICE: DO NOT DISCARD THIS MANUAL

QUADRA-FIRE®

EXPLORER I WOOD APPLIANCE

MODEL(S):
EXPLR-I-MBK
EXPLR-I-PBK
EXPLR-I-PDB
EXPLR-I-PFT
EXPLR-I-PMH

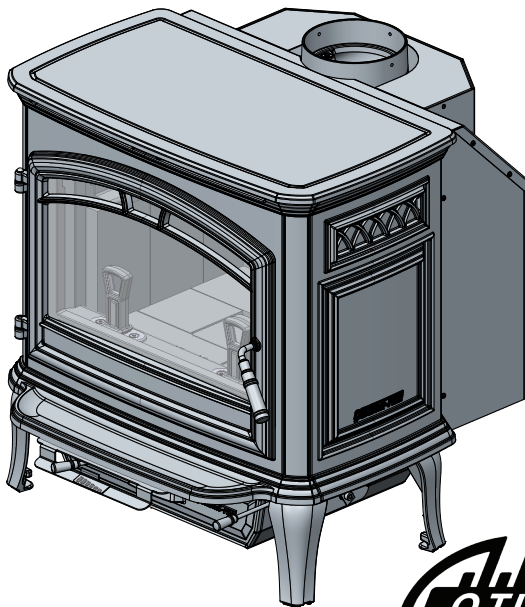

WARNING



If the information in these instructions is not followed exactly, a fire could result causing property damage, personal injury, or death.

- Do not store or use gasoline or other flammable vapors and liquids in the vicinity of this or any other appliance.
- Do not over-fire - If appliance or chimney connector glows, you are over-firing. Over-firing will void your warranty.
- Comply with all minimum clearances to combustibles as specified. Failure to comply may cause house fire.

WARNING



HOT SURFACES!

Glass and other surfaces are hot during operation AND cool down.

Hot glass and appliance will cause burns.

- Do not touch glass until it is cooled
- Use leather gloves when reloading fuel
- NEVER allow children to touch glass
- Keep children away
- CAREFULLY SUPERVISE children in same room as appliance.
- Alert children and adults to hazards of high temperatures
- **High temperatures may ignite clothing or other flammable materials.**
- Keep clothing, furniture, draperies and other flammable materials away.

WARNING



Fire Risk.

For use with solid wood fuel only.
Other fuels may over-fire and generate poisonous gases (i.e. carbon monoxide).

NOTE

To obtain a French translation of this manual, please contact your dealer or visit www.quadrafire.com

Pour obtenir une traduction française de ce manuel, s'il vous plaît contacter votre revendeur ou visitez www.quadrafire.com

Installation and service of this appliance should be performed by qualified personnel. Hearth & Home Technologies recommends HHT Factory Trained or NFI certified professionals.

hearthED
FACTORY TRAINING
Fuel Your Fire

NFI NATIONAL
FIREPLACE
INSTITUTE®
A CERTIFICATION AGENCY



and Welcome to the Quadra-Fire Family!

NOTE: Clearances may only be reduced by means approved by the regulatory authority having jurisdiction

A. Sample of Serial Number / Safety Label

LOCATION: Back of appliance

CAUTION: HOT WHILE IN OPERATION DO NOT TOUCH, KEEP CHILDREN AND CLOTHING AWAY. CONTACT MAY CAUSE SKIN BURNS
ATTENTION: KEEP FURNISHINGS AND OTHER COMBUSTIBLE MATERIAL FAR AWAY FROM THE APPLIANCE. SEE NAMEPLATE AND INSTRUCTIONS

CHAUDS LORS DE L'OPERATION. NE PAS TOUCHER. GARDEZ LES ENFANTS ET LES VÊTEMENTS LOIN DE L'ESPACE DÉSIGNÉ DE L'INSTALLATION. LE CONTACT PEUT CAUSER DES BRÛLURES À LA PEAU. GARDEZ LES MEUBLES ET LES MATÉRIAUX COMBUSTIBLES LOIN DE L'ESPACE DÉSIGNÉ DE L'APPAREIL. VOIR L'ÉTIQUETTE ET LES INSTRUCTIONS.

LISTED ROOM HEATER, SOLID FUEL TYPE. ALSO FOR USE IN MOBILE HOMES ONLY. (UM) 84 HUD. *For Use with Solid Wood Fuel Only!

PREVENT HOUSE FIRES
 Install and use only in accordance with manufacturer's installation and operating instructions. Contact local building or fire officials about restrictions and installation inspections in your area. Do not obstruct the space beneath heater.

WARNING - For Mobile Homes: Do not install in a sleeping room. An outside combustion air inlet must be provided and unrestricted white unit to in use. The structural integrity of the mobile home floor, ceiling and walls must be maintained. The stove needs to be properly grounded to the frame of the mobile home. Components required for mobile home installation: Outside Air Kit, Part Number QAK-AAC. Refer to manufacturer's instructions and local codes for precautions required for passing chimney through a combustible wall or ceiling and maximum offsets. Inspect and clean chimney frequently - Under Certain Conditions of Use, Crestose Buildup May Occur Rapidly. Do not connect this unit to a chimney serving another appliance. Optional Component: Optional Blower, Part BK-ACC. Electrical Rating: 115 VAC, 1.2 Amps, 60 Hz. Route power cord away from unit. Do not route cord under or in front of appliance. **DANGER: Risk of electrical shock.** Disconnect power supply before servicing. Replace glass only with 5/8" ceramic available from your dealer. Do not use grate or elevate fire. Build wood fire directly on hearth. Do not overfire - if heater or chimney connector glows, you are overfiring. Operate only with the fuel loading door closed. Open only to add fuel to the fire.

FLOOR PROTECTION:
 It is necessary to install a Type II floor protector not less than 3/8 inch (9.5mm) thick with a minimum R value of 1.06, a minimum of 16 inches (406mm) in front of glass, and 8 inches (203mm) to both sides of the fuel loading door. Open the door and measure 8 inches (203mm) from the side edge of the opening in the face of the appliance.

APPAREIL DE CHAUFFAGE DE PIÈCE, DE TYPE DE COMBUSTIBLE SOLIDE, PAS APPROUVÉ POUR MOBILE HOME INSTALLATIONS AU CANADA
 Usage Avec Bois Solide Sécurisé!

PRÉVENTION DES FEUX DE MAISON
 Installez et utilisez en accord avec les instructions d'installation et d'opération du fabricant. Contactez le bureau de la construction ou le bureau des incendies au sujet des restrictions et des inspections d'installation dans votre voisinage. Ne pas obstruer l'espace en dessous de l'appareil.

AVERTISSEMENT - Pour Mobile Homes: Ne pas installer dans une chambre à coucher. Une prise d'air extérieure de combustion doit être fournie et sans restriction à l'intérieur du mobile home. L'intégrité structurelle du plancher, du plafond et des murs doit être maintenue. Le poêle doit être correctement relié à la structure du mobile home. Les composants requis pour l'installation dans un mobile home: Kit d'Air Extérieur, Numéro de Pièce QAK-AAC. Consultez les instructions et les codes locaux pour les précautions requises pour faire passer une cheminée à travers un mur ou un plafond combustible, et les dérogations maximales. Inspectez et nettoyez la cheminée fréquemment. Sous certaines conditions, il se peut que la croûte s'accumule rapidement. Ne pas connecter cet appareil à une cheminée servant un autre appareil. Composants Optionnels: Ventilateur Optionnel, Pièce BK-ACC. Puissance Électrique: 115 VAC, 1,2 Amps, 60 Hz. Enlevez le fil électrique de l'appareil. Ne pas faire passer le fil électrique au dessus ou en dessous de l'appareil. DANGER: il y a risque de décharge électrique. Déconnectez le fil électrique de la prise de contact avant le service. Remplacez la vitre seulement avec une vitre céramique de 5/8 pouce (12,7 mm) épaisseur. Ne construisez pas de feu dans le poêle. Ne construisez pas de feu dans le poêle. Remplacez la vitre seulement avec une vitre céramique de 5/8 pouce (12,7 mm) épaisseur. Ne construisez pas de feu dans le poêle. Remplacez la vitre seulement avec une vitre céramique de 5/8 pouce (12,7 mm) épaisseur. Ne construisez pas de feu dans le poêle.

VENT SPECIFICATIONS:
SINGLE WALL: Six inch (6 inches) (152mm) diameter, minimum 24 MSG black or blue steel connector pipe, with a listed factory-built UL103HT* Class "A" chimney, suitable for use with solid fuels, or a masonry chimney, and the referenced clearances.
DOUBLE WALL: Six inch (6 inches) (152mm) diameter, listed double wall insulated connector pipe with listed factory-built UL103HT* Class "A" chimney, or masonry chimney and the referenced clearances.
***In Canada must comply with Standard CANULC-S629-M87 for the 600 Factory-built chimneys.**
MOBILE HOME, USA ONLY: Use double wall pipe by Dura-Vent DVL, Safety Merchants DS. Security DL double wall connector pipe. Must be equipped with spark arrestor. Allow specified clearances below with venting unit.

MINIMUM CLEARANCES TO COMBUSTIBLES IN INCHES (Millimeters)
 NOTE: All "A", "B" and "P" Dimensions are to the outside of the flue collar.

	A	B	C	D	E	G	H	I	J	
SINGLE WALL PIPE	17 (432)	24 (607)	11 (279)		18 (457)	53.5 (1359)		NA	NA	CONDUIT OU MUR SIMPLE
DOUBLE WALL PIPE	9 (229)	10 (254)	10 (254)		13.5 (343)	53.5 (1359)		NA	NA	CONDUIT OU MUR DOUBLE
DOUBLE WALL PIPE WITH 3" OFFSET	12.5 (318)	11 (279)			NA	53.5 (1359)	18 (457)	NA	NA	CONDUIT OU MUR SIMPLE
DOUBLE WALL PIPE WITH 6" OFFSET	8 (203)	11 (279)			NA	53.5 (1359)	18 (457)	NA	NA	CONDUIT OU MUR DOUBLE
SINGLE WALL PIPE WITH 3" OFFSET	NA	8 (203)	24 (607)	11 (279)	NA	53.5 (1359)		8 (203)	53.5 (1359)	CONDUIT OU MUR SIMPLE

INSTALLATION: FULL VENT THROUGH ALCOVE - Vertical complète en alcove

INSTALLATION: THROUGH BACKWALL / STOVE THROUGH BACKWALL / DESSUS DE HAUT DU POÊLE À TRAVERS LE MUR ARRIÈRE

INSTALLATION: CORNER / CORNER INSTALLATION

INSTALLATION: THROUGH CEILING / CLEARANCE OVER CEILING / ESPACE LIBRE DE L'APPAREIL AU PLAFOND AVEC 90° DE COURBURE

INSTALLATION: THROUGH WALL / HORIZONTAL THRU WALL

MAINTENANCE: 12" MAX

Serial No.

Mfg. Date

Model Name

Test Lab & Report No.

Manufactured by:
 HEARTH-TO-HOME
 382 Mountain House Road,
 Halifax, PA 17032
 www.quadrafire.com

Serial No. / N° de série

2018	2019	2020
<input type="checkbox"/>	<input type="checkbox"/>	<input type="checkbox"/>
JAN	FEB	MAR
<input type="checkbox"/>	<input type="checkbox"/>	<input type="checkbox"/>
JUN	JUL	AUG
<input type="checkbox"/>	<input type="checkbox"/>	<input type="checkbox"/>
SEP	OCT	NOV
<input type="checkbox"/>	<input type="checkbox"/>	<input type="checkbox"/>
DEC		

DO NOT REMOVE THIS LABEL / NE PAS ENLEVER L'ÉTIQUETTE

U.S. ENVIRONMENTAL PROTECTION AGENCY
 Certified to comply with 2015 particulate emission standards at 2.2 g/hr EPA method 989, ASTM E6215. Not approved for sale after May 15, 2020.

This wood heater needs periodic inspection and repair for proper operation. Consult the owner's manual for instructions on how to inspect against federal regulations to operate this wood heater in a manner inconsistent with the operating instructions in the owner's manual.

Owner's Manual

Installation Manual

Made in U.S.A. of US and imported parts.
 Fabriqué aux États-Unis d'Amérique par des pièces d'origine américaine et pièces importées.
 7062-196D

Safety Alert Key:



- **DANGER!** Indicates a hazardous situation which, if not avoided will result in death or serious injury.
- **WARNING!** Indicates a hazardous situation which, if not avoided could result in death or serious injury.
- **CAUTION!** Indicates a hazardous situation which, if not avoided, could result in minor or moderate injury.
- **NOTICE:** Indicates practices which may cause damage to the appliance or to property.

TABLE OF CONTENTS

<p>A. Sample of Serial Number / Safety Label 2</p> <p>B. Warranty Policy 4</p> <p>C. Quick Start Guide 7</p> <p>1 Listing and Code Approvals 8</p> <p> A. Appliance Certification 8</p> <p> B. BTU & Efficiency Specifications 8</p> <p> C. Glass Specifications 9</p> <p> D. Mobile Home Approved (USA only). 9</p> <p> E. Sleeping Room 9</p> <p> F. California - Prop65. 9</p> <p>2 Operating Instructions 10</p> <p> A. Over-Firing Your Appliance 10</p> <p> B. Wood Selection & Storage 10</p> <p> C. Burning Process 10</p> <p> D. Automatic Combustion Control (ACC). 11</p> <p> E. Air Controls 11</p> <p> F. Burn Rates and Operating Efficiency. 12</p> <p> G. Building A Fire 13</p> <p> H. Correct Baffle & Blanket Placement 14</p> <p> I. Blower Operating Instructions 15</p> <p> J. Opacity (Smoke) 15</p> <p> K. Clear Space. 16</p> <p> L. Negative Pressure 16</p> <p> M. Frequently Asked Questions. 17</p>	<p>3 Maintenance and Service 18</p> <p> A. Quick Reference Maintenance Guide 18</p> <p> B. General Maintenance 19</p> <p>4 Troubleshooting Guide 21</p> <p>5 Service Part Replacement 22</p> <p> A. Glass Replacement - Door Assembly 22</p> <p> B. Firebrick Replacement 22</p> <p> C. Snap Disc Replacement 22</p> <p> E. Baffle Removal 23</p> <p> F. Tube Channel Assembly Replacement 24</p> <p>6 Reference Materials 25</p> <p> A. Service & Maintenance Log 25</p> <p> B. Expanded View 27</p> <p> C. Service Parts and Accessory List 28</p>
---	--

Quadra-Fire is a registered trademark of Hearth & Home Technologies.

B. Warranty Policy

**Hearth & Home Technologies
LIMITED LIFETIME WARRANTY**

Hearth & Home Technologies, on behalf of its hearth brands (“HHT”), extends the following warranty for HHT gas, wood, pellet and electric hearth appliances that are purchased from an HHT authorized dealer.

WARRANTY COVERAGE:

HHT warrants to the original owner of the HHT appliance at the site of installation, and to any transferee taking ownership of the appliance at the site of installation within two years following the date of original purchase, that the HHT appliance will be free from defects in materials and workmanship at the time of manufacture. After installation, if covered components manufactured by HHT are found to be defective in materials or workmanship during the applicable warranty period, HHT will, at its option, repair or replace the covered components. HHT, at its own discretion, may fully discharge all of its obligations under such warranties by replacing the product itself or refunding the verified purchase price of the product itself. The maximum amount recoverable under this warranty is limited to the purchase price of the product. This warranty is subject to conditions, exclusions and limitations as described below.

WARRANTY PERIOD:

Warranty coverage for consumers begins at the date of installation. In the case of new home construction, warranty coverage begins on the date of first occupancy of the dwelling or six months after the sale of the product by an independent, authorized HHT dealer/distributor, whichever occurs earlier. However, the warranty shall commence no later than 24 months following the date of product shipment from HHT, regardless of the installation or occupancy date. The warranty period for parts and labor for covered components is produced in the following table.

The term “Limited Lifetime” in the table below is defined as: 20 years from the beginning date of warranty coverage for gas appliances, and 10 years from the beginning date of warranty coverage for wood and pellet appliances. These time periods reflect the minimum expected useful lives of the designated components under normal operating conditions.

Warranty Period		HHT Manufactured Appliances and Venting					
Parts	Labor	Gas	Pellet	Wood	Electric	Venting	Components Covered
1 Year		X	X	X	X	x	All parts and material except as covered by Conditions, Exclusions, and Limitations listed
2 years			X	X			Igniters, auger motors, electronic components, and glass
		X	X	X			Factory-installed blowers
				X			Molded refractory panels
		X					Ignition Modules
3 years			X				Firepots, burnpots, mechanical feeders/auger assemblies
5 years	1 year	X					Vent Free burners, Vent Free ceramic fiber logs, Aluminized Burners
			X	X			Castings and Baffles
6 years	3 years			X			Catalyst - limitations listed
7 years	3 years		X	X			Manifold tubes, HHT chimney and termination
10 years	1 year	X					Burners, logs and refractory
Limited Lifetime	3 years	X	X	X			Firebox and heat exchanger, Grate and Stainless Steel Burners, FlexBurn® System (engine, inner cover, access cover and fireback)
90 Days		X	X	X	X	X	All replacement parts beyond warranty period

WARRANTY CONDITIONS:

- This warranty only covers HHT appliances that are purchased through an HHT authorized dealer or distributor. A list of HHT authorized dealers is available on the HHT branded websites.
- This warranty is only valid while the HHT appliance remains at the site of original installation.
- This warranty is only valid in the country in which the HHT authorized dealer or distributor that sold the appliance resides.
- Contact your installing dealer for warranty service. If the installing dealer or distributor is unable to provide necessary parts, contact the nearest HHT authorized dealer or supplier. Additional service fees may apply if you are seeking warranty service from a dealer other than the dealer from whom you originally purchased the product.
- Check with your dealer in advance for any costs to you when arranging a warranty call. Travel and shipping charges for parts are not covered by this warranty.
- Limited Catalyst Warranty
 - o For wood burning products containing a catalyst, the catalyst will be warranted for a six-year period as follows: if the original catalyst or a replacement catalyst proves defective or ceases to maintain 70% of its particulate emission reduction activity (as measured by an approved testing procedure) within 36 months from the purchase date, the catalyst will be replaced for free.
 - o From 37 to 72 months a pro-rated credit will be allowed against a replacement catalyst and labor credit necessary to install the replacement catalyst. The proration rate is as follows:

Amount of Time Since Purchase	Credit Towards Replacement Cost
0 - 36 Months	100%
37 - 48 Months	30%
49 - 60 Months	20%
61 - 72 Months	10%

- o Any replacement catalyst will be warranted under the terms of the catalyst warranty for the remaining term of the original warranty. The purchaser must provide the name, address, and telephone number of the location where the product is installed, proof of original purchase date, date of failure, and any relevant information regarding the failure of the catalyst.

WARRANTY EXCLUSIONS:

This warranty does not cover the following:

- Changes in surface finishes as a result of normal use. As a heating appliance, some changes in color of interior and exterior surface finishes may occur. This is not a flaw and is not covered under warranty.
- Damage to printed, plated, or enameled surfaces caused by fingerprints, accidents, misuse, scratches, melted items, or other external sources and residues left on the plated surfaces from the use of abrasive cleaners or polishes.
- Repair or replacement of parts that are subject to normal wear and tear during the warranty period are not covered. These parts include: paint, wood and pellet gaskets, firebricks, grates, flame guides, batteries and the discoloration of glass.
- Minor expansion, contraction, or movement of certain parts causing noise. These conditions are normal and complaints related to this noise are not covered by this warranty.
- Damages resulting from: (1) failure to install, operate, or maintain the appliance in accordance with the installation instructions, operating instructions, and listing agent identification label furnished with the appliance; (2) failure to install the appliance in accordance with local building codes; (3) shipping or improper handling; (4) improper operation, abuse, misuse, continued operation with damaged, corroded or failed components, accident, or improperly/incorrectly performed repairs (5) environmental conditions, inadequate ventilation, negative pressure, or drafting caused by tightly sealed constructions, insufficient make-up air supply, or handling devices such as exhaust fans or forced air furnaces or other such causes; (6) use of fuels other than those specified in the operation instructions; (7) installation or use of components not supplied with the appliance or any other components not expressly authorized and approved by HHT; (8) modification of the appliance not expressly authorized and approved by HHT in writing; and/or (9) interruptions or fluctuations of electrical power supply to the appliance.
- Non-HHT venting components, hearth connections or other accessories used in conjunction with the appliance.
- Any part of a pre-existing fireplace system in which an insert or a decorative gas appliance is installed.
- HHT’s obligation under this warranty does not extend to the appliance’s capability to heat the desired space. Information is provided to assist the consumer and the dealer in selecting the proper appliance for the application. Consideration must be given to the appliance location and configuration, environmental conditions, insulation and air tightness of the structure.

This warranty is void if:

- The appliance has been over-fired, operated in atmospheres contaminated by chlorine, fluorine, or other damaging chemicals. Over-firing can be identified by, but not limited to, warped plates or tubes, deformation/warping of interior cast iron structure or components, rust colored cast iron, bubbling, cracking and discoloration of steel or enamel finishes.
- The appliance is subjected to prolonged periods of dampness or condensation.
- There is any damage to the appliance or other components due to water or weather damage which is the result of, but not limited to, improper chimney or venting installation.

LIMITATIONS OF LIABILITY

- The owner's exclusive remedy and HHT's sole obligation under this warranty, under any other warranty, express or implied, or in contract, tort or otherwise, shall be limited to replacement, repair, or refund, as specified above. In no event will HHT be liable for any incidental or consequential damages caused by defects in the appliance. Some states do not allow exclusions or limitation of incidental or consequential damages, so these limitations may not apply to you. This warranty gives you specific rights; you may also have other rights, which vary from state to state. EXCEPT TO THE EXTENT PROVIDED BY LAW, HHT MAKES NO EXPRESS WARRANTIES OTHER THAN THE WARRANTY SPECIFIED HEREIN. THE DURATION OF ANY IMPLIED WARRANTY IS LIMITED TO DURATION OF THE EXPRESSED WARRANTY SPECIFIED ABOVE.

C. Quick Start Guide

Note: These are generic drawings and may not represent your specific model.

ITEMS NEEDED FOR FIRST FIRE: 10 Pieces of Newspaper, 10-20 Pieces of Dry Kindling and a Few Pieces of Dry Split Wood.

OPEN AIR CONTROLS

HIGH Burn Rate Control

ACC Control

HIGH

1

LOAD WOOD

2

ADD NEWSPAPER

3

ADD KINDLING

LIGHT THE PAPER

4

WARNING! Risk of Fire

Close and securely latch the door after the fire has started, and after refueling, to prevent:

- Spillage of smoke, flame and carbon monoxide
- Spillage of sparks, coals, and logs
- Over firing

DO NOT leave the appliance unattended with the door open. Starting a fire may not require an open door for draft. The air control should supply adequate draft.

5

ADD MORE WOOD

6

REDUCE AIR CONTROLS

Set to desired heat output.

LOW Burn Rate Control

ACC Control

LOW

7

The appliance is ready for normal operation.

1 Listing and Code Approvals

A. Appliance Certification

Model:	Explorer I Wood Appliance
Laboratory:	OMNI Test Laboratories Inc.
Report No:	0061WS091S
Type:	Safety
Standard:	UL 1482-11 & 737-11; ULC S627-00

B. BTU & Efficiency Specifications

EPA Certified Emissions:	2.2 grams per hour
*LHV Tested Efficiency:	80.1%
**HHV Tested Efficiency:	74.1%
***EPA BTU Output:	12,100 to 32,000 / hr.
****Peak BTU/Hour Output:	52,400
Vent Size:	6 inches
Firebox Size:	1.68 cubic feet
Recommended Log Length	16 inches
Fuel Orientation:	Side to Side
Fuel	Seasoned Cord Wood

*Weighted average LHV (Low Heating Value) efficiency using Douglas Fir dimensional lumber and data collected during EPA emission test. LHV assumes the moisture is already in a vapor state so there is no loss in energy to vaporize.

**Weighted average HHV (High Heating Value) efficiency using Douglas Fir dimensional lumber and data collected during EPA emission test. HHV includes the energy required to vaporize the water in the fuel.

***A range of BTU outputs based on EPA Default Efficiency and the burn rates from the low and high EPA tests, using Douglas Fir dimensional lumber.

****The peak BTU out of the appliance is calculated using the maximum first hour burn rate from the High EPA Test and the BTU content of cord wood (8600) times the efficiency.

NOTE: This installation must conform with local codes. In the absence of local codes you must comply with the UL1482-11, UL 737-11, (UM) 84-HUD and NPFA211 in the U.S.A. and the ULC S627-00 and CAN/CSA-B365 Installation Codes in Canada. **NOT APPROVED FOR MOBILE HOME INSTALLATIONS IN CANADA!**

The Quadra-Fire Explorer I Wood Appliance (ACC) meets the U.S. Environmental Protection Agency's crib wood emission limits for wood appliances sold after May 15, 2015.

This wood appliance needs periodic inspection and repair for proper operation. It is against federal regulations to operate this wood appliance in a manner inconsistent with operating instructions in this manual.

C. Glass Specifications

This appliance is equipped with 5mm ceramic glass. Replace glass only with 5mm ceramic glass. Please contact your dealer for replacement glass.

D. Mobile Home Approved (USA only)

- This appliance is approved for mobile home installations when not installed in a sleeping room and when an outside combustion air inlet is provided.
- The structural integrity of the mobile home floor, ceiling, and walls must be maintained.
- The appliance must be properly grounded to the frame of the mobile home with #8 copper ground wire, and chimney must be listed to UL103 HT or a listed UL-1777 full length six inch (152mm) diameter liner must be used.
- Outside Air Kit, part OAK-ACC must be installed in a mobile home installation.

E. Sleeping Room

When installed in a sleeping room it is recommended that a smoke and/or CO alarm be installed in the bedroom. The size of the room must be at least 50ft³ per 1,000 Btu/hr stove input, if the stove exceeds the room size, out air must be installed.

F. California - Prop65

 WARNING
<p>This product and the fuels used to operate this product (wood), and the products of combustion of such fuels, can expose you to chemicals including carbon black, which is known to the State of California to cause cancer, and carbon monoxide, which is known to the State of California to cause birth defects or other reproductive harm. For more information go to: WWW.P65Warnings.ca.gov</p>

 WARNING
<p>Fire Risk. Hearth & Home Technologies disclaims any responsibility for, and the warranty will be voided by, the following actions:</p> <ul style="list-style-type: none"> • Installation and use of any damaged appliance. • Modification of the appliance. • Installation other than as instructed by Hearth & Home Technologies. • Installation and/or use of any component part not approved by Hearth & Home Technologies. • Operating appliance without fully assembling all components. • Operating appliance without legs attached (if supplied with appliance). • Do NOT Over fire - If appliance or chimney connector glows, you are over firing. <p>Any such action that may cause a fire hazard.</p>

Improper installation, adjustment, alteration, service or maintenance can cause injury or property damage. For assistance or additional information, consult a qualified installer, service agency or your dealer.

<p>NOTE: Hearth & Home Technologies, manufacturer of this appliance, reserves the right to alter its products, their specifications and/or price without notice.</p>

User Guide

2 Operating Instructions

A. Over-Firing Your Appliance



WARNING



Fire Risk.

Do not over-fire.

Over-firing may ignite creosote or will damage the appliance and chimney.

To prevent over-firing your appliance, DO NOT:

- Use flammable liquids
- Overload with wood
- Burn trash or large amounts of scrap lumber
- Permit too much air to the fire

Visit www.quadrafire.com/shopping-tools/videos to view product and use & care videos.

1. Symptoms of Over-Firing

Symptoms of over-firing may include one or more of the following:

- Chimney connector or appliance glowing
- Roaring, rumbling noises
- Loud cracking or banging sounds
- Metal warping
- Chimney fire

2. What To Do if Your Appliance is Over-Firing

- Immediately close the door and air controls to reduce air supply to the fire.
- If you suspect a chimney fire, call the fire department and evacuate your house.
- Contact your local chimney professional and have your appliance and appliance pipe inspected for any damage.
- Do not use your appliance until the chimney professional informs you it is safe to do so.

Hearth & Home Technologies WILL NOT warranty appliances that exhibit evidence of over-firing. Evidence of over-firing includes, but is not limited to:

- Warped air tube
- Deteriorated refractory brick retainers
- Deteriorated baffle and other interior components

B. Wood Selection & Storage

Burn only dry seasoned wood. Store wood under cover, out of the rain and snow. Dry and well-seasoned wood will not only minimize the chance of creosote formation, but will give you the most efficient fire. Even dry wood contains at least 15% moisture by weight, and should be burned hot enough to keep the chimney hot for as long as it takes to dry the wood out - about one hour. It is a waste of energy to burn unseasoned wood of any kind.

Dead wood lying on the forest floor should be considered wet, and requires full seasoning time. Standing dead wood can be considered to be about 2/3 seasoned. To tell if wood is dry enough to burn, check the ends of the logs. If there are cracks radiating in all directions from the center, it is dry. If your wood sizzles in the fire, even though the surface is dry, it may not be fully cured.

Splitting wood before it is stored reduces drying time. Wood should be stacked so that both ends of each piece are exposed to air, since more drying occurs through the cut ends than the sides. This is true even with wood that has been split. Store wood under cover, such as in a shed, or covered with a tarp, plastic, tar paper, sheets of scrap plywood, etc., as uncovered wood can absorb water from rain or snow, delaying the seasoning process.

C. Burning Process

In recent years there has been an increasing concern about air quality. Much of the blame for poor air quality has been placed on the burning of wood for home heating. In order to improve the situation, we at Quadra-Fire have developed cleaner-burning wood appliances that surpass the requirements for emissions established by our governing agencies. These wood appliances, like any other appliances, must be properly operated in order to insure that they perform the way they are designed to perform. Improper operation can turn most any wood appliance into a smoldering environmental hazard.

1. Kindling or First Stage

It helps to know a little about the actual process of burning in order to understand what goes on inside a appliance. The first stage of burning is called the kindling stage. In this stage, the wood is heated to a temperature high enough to evaporate the moisture which is present in all wood. The wood will reach the boiling point of water (212°F) and will not get any hotter until the water is evaporated. This process takes heat from the coals and tends to cool the appliance.

Fire requires three things to burn - fuel, air and heat. So, if heat is robbed from the appliance during the drying stage, the new load of wood has reduced the chances for a good clean burn. For this reason, it is always best to burn dry, seasoned firewood. When the wood isn't dry, you must open the air controls and burn at a high burn setting for a longer time to start it burning. The heat generated from the fire should be warming your home and establishing the flue draft, not evaporating the moisture out of wet, unseasoned wood, resulting in wasted heat.

2. Second Stage

The next stage of burning, the secondary stage, is the period when the wood gives off flammable gases which burn above the fuel with bright flames. During this stage of burning it is very important that the flames be maintained and not allowed to go out. This will ensure the cleanest possible fire. If the flames tend to go out, it is set too low for your burning conditions. The air control located at the upper right hand corner is used to adjust for burn rates. This is called the Burn Rate Air Control (Figure 11.1).

3. Final Stage

The final stage of burning is the charcoal stage. This occurs when the flammable gases have been mostly burned and only charcoal remains. This is a naturally clean portion of the burn. The coals burn with hot blue flames.

It is very important to reload your appliance while enough lively hot coals remain in order to provide the amount of heat needed to dry and rekindle the next load of wood. It is best to open the Burn Rate Air and Start-Up Air Controls before reloading. This livens up the coal bed and reduces excessive emissions (opacity/smoke). Open door slowly so that ash or smoke does not exit appliance through opening. You should also break up any large chunks and distribute the coals so that the new wood is laid on hot coals.

Air quality is important to all of us, and if we choose to use wood to heat our homes we should do so responsibly. To do this we need to learn to burn our appliances in the cleanest way possible. Doing this will allow us to continue using our wood appliances for many years to come.

D. Automatic Combustion Control (ACC)

Typically, when you build a fire, you open the air controls fully and monitor the fire to prevent it from going into an over fire situation and/or burning your wood up too quickly before you shut down the air controls to the desired burn rate. With the Automatic Combustion Control (ACC) system, you do not have to continually monitor the fire. Once you set the ACC system it will control the fire for you. Follow the instructions below to learn how to operate your appliance with ease.

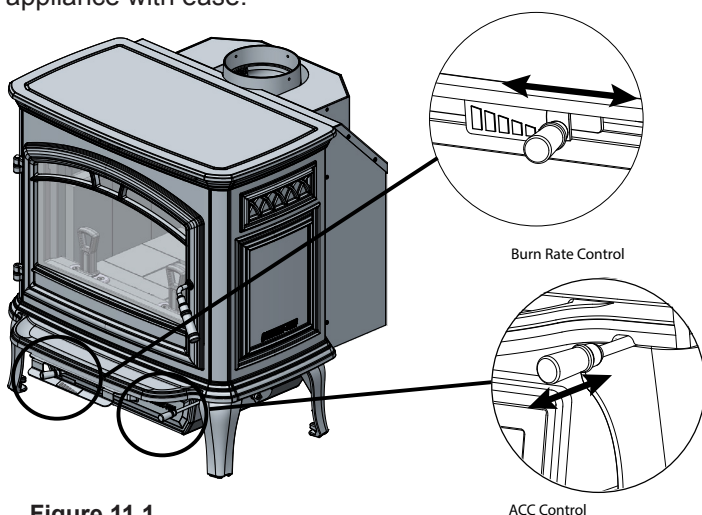

Figure 11.1

E. Air Controls

1. Burn Rate Air Control

This air supply enters at the upper front of the firebox, near the top of the glass door. This preheated air supplies the necessary fresh oxygen to mix with the unburned gases, helping to create second, third and fourth combustions. This air is regulated by the Burn Rate Air Control. When the control is moved all the way to the left it is on the High setting and when moved all the way to the right it is on the Low setting (Figure 11.1).

2. Start-Up Air Control

The Start-Up Air Control function is to activate the Automatic Combustion Control system (ACC). This function is performed by pushing the control all the way back until it stops and then pulling forward to the front of the appliance until it stops. This activates the ACC system and opens the front air channel and allows air to enter the front of the appliance for approximately 25 minutes. The front air channel gradually shuts down until it is completely closed at the end of the 25 minutes. The fire is now controlled by the air supplied by the Burn Rate Air Control. This function should be performed each time you reload the appliance. Start up air can be locked open for High burn setting if desired; see page 10 for instructions (Figure 11.1).

3. Manual Timer Over-Ride

If you need to shut the ACC system off before it shuts itself off after 25 minutes (i.e. over fire situation), reach down to the bottom right and pull the lever toward you (Figure 11.2).

CAUTION

Injury Risk.

- Gloves recommended

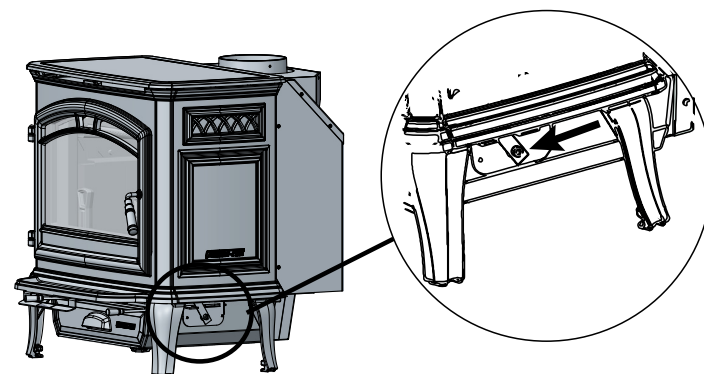

Figure 11.2

F. Burn Rates and Operating Efficiency

This wood appliance has a manufacturer-set minimum low burn rate that must not be altered. It is against federal regulations to alter this setting or otherwise operate this wood appliance in a manner inconsistent with operating instructions in this manual.

For maximum operating efficiency

1. This appliance has a timer system (ACC) that operates the appliance at its maximum efficiency removing any guess work for the homeowner. Follow the instructions below for each burn rate for the Start-Up Air Control and Burn Rate Air Control (**Figure 12.1**).
2. Burn dry, well-seasoned wood.

Burn Rate examples

Primary control is open when moved to the left.

1. Low burn setting: Move burn rate control to far right. Activate the startup air by pushing in and pulling out.
2. Medium low burn setting: Move burn rate control left from low setting 1/8"-1/2". Activate startup air by pushing in and pulling out.
3. Medium high burn setting: Move burn rate control to far left. Activate the startup air by pushing in and pulling out.
4. High burn setting: Move burn rate control to far left. Activate the startup air by pushing in without pulling back. This locks ACC open for maximum combustion air.

NOTE: 1-3 burn settings the fan shall be off for the first 30 minutes and then be operated in the high position. High burn setting, fan shall be may continue to be on full after the loading of the fuel.

NOTE: Due to altitude and other circumstances this operation information is a guideline, appliances may run settings not in accordance with these guidelines to achieve same desired burn rates.

NOTE: Operate appliance on High Burn 45 minutes a day to help keep flue/chimney clean.

WARNING

Risk of Fire.



When set on High Burn Rate and over-riding the Automatic Combustion Control system an over fire situation can occur and may result in a chimney fire.

Over firing will void the appliance warranty.

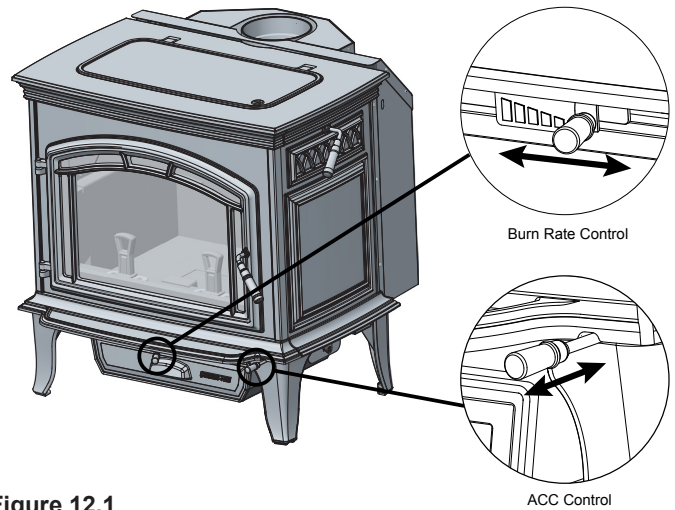

Figure 12.1

G. Building A Fire

Before lighting your first fire in the appliance:

NOTE: The special high temperature paint that your appliance is finished with will cure as your appliance heats. You will notice an odor and perhaps see some vapor rise from the appliance surface; this is normal. We recommend that you open a window until the odor dissipates and paint is cured.

1. Confirm the baffle is correctly positioned. It should be even with the front tube and resting on all tubes (**Figure 13.1 and 13.2**).
2. Remove all labels from glass and inside of appliance.

There are many ways to build a fire. The basic principle is to light easily-ignitable tinder or paper, which ignites the fast burning kindling, which in turn ignites the slow-burning firewood. Here is one method that works well:

1. Open the Burn Rate Air and ACC Controls fully (Refer to page 6 Start-Up Guide).
2. Place several wads of crushed paper on the firebox floor. Heating the flue with slightly crumpled newspaper before adding kindling keeps smoke to a minimum.
3. Lay small dry sticks of kindling on top of the paper.
4. Make sure that no matches or other combustibles are in the immediate area of the appliance. Be sure the room is adequately ventilated and the flue unobstructed.
5. Light the paper in the appliance. NEVER light or rekindle fire with kerosene, gasoline, or charcoal lighter fluid; the results can be fatal.
6. Once the kindling is burning quickly, add several full-length logs 3 inches (76mm) or 4 inches (102mm) in diameter. Be careful not to smother the fire. Stack the pieces of wood carefully; near enough to keep each other hot, but far enough away from each other to allow adequate air flow between them.
7. Set the Burn Rate Air Control and activate the ACC timer system.
8. When ready to reload, It is best to fully open both the Burn Rate Air and Start-up Air Controls **before reloading**. This livens up the coal bed and reduces excessive emissions (opacity/smoke). Open door slowly so that ash or smoke does not exit appliance through opening. Large logs burn slowly, holding a fire longer. Small logs burn fast and hot, giving quick heat.
9. As long as there are hot coals, repeating steps 6 through 8 will maintain a continuous fire.

NOTE:

- Build fire on brick firebox floor.
- Do NOT use grates, andirons or other methods to support fuel. It will adversely affect emissions.

! WARNING



Fire Risk.

Do NOT store wood:

- Closer than required clearances to combustibles to appliance
- Within space required for loading or ash removal.

Do NOT operate appliance:

- With appliance door open.
- With ash removal system door open.

Baffle Board even with front tube & resting on all tubes

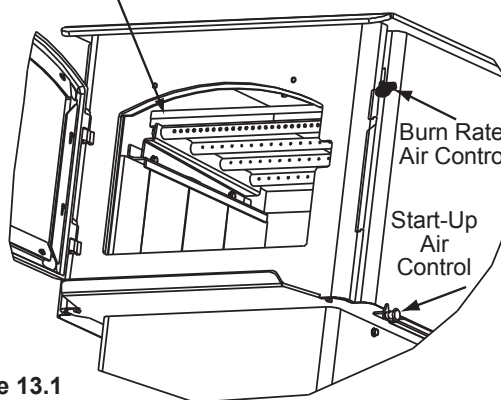

Figure 13.1

Ceramic Blanket on Top

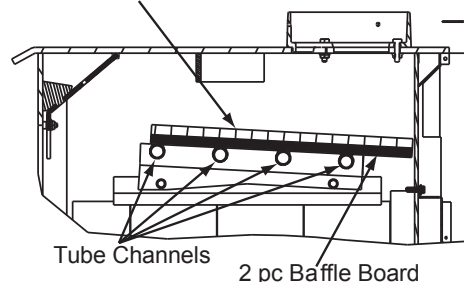

Figure 13.2

! WARNING



Fire Risk.

- Do NOT burn wet or green wood.
 - Store wood in dry location.
 - Stack wood so both ends are exposed to air.
- Wet, unseasoned wood can cause accumulation of creosote.

H. Correct Baffle & Blanket Placement



WARNING

Fire Risk.

Firebox damage due to improper baffle placement is not covered by warranty. Operate the wood burning appliance with the baffle in the correct position only.



Not doing so could result in:

- Reduced efficiency
- Overheating the chimney
- Overheating the rear of the firebox
- Poor performance

Ensure correct baffle placement and replace baffle components if damaged or missing.

CAUTION

The baffle boards are FRAGILE. Use extreme caution when loading firewood to prevent:

- Cracking, breaking or damaging the baffle boards
- DO NOT operate the appliance without baffle boards

CORRECT POSITION

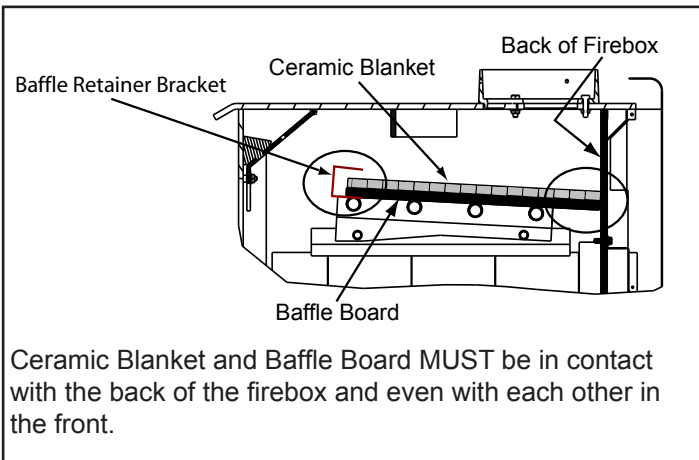
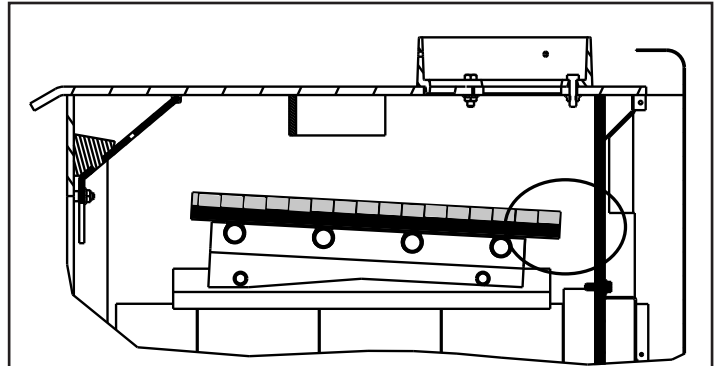
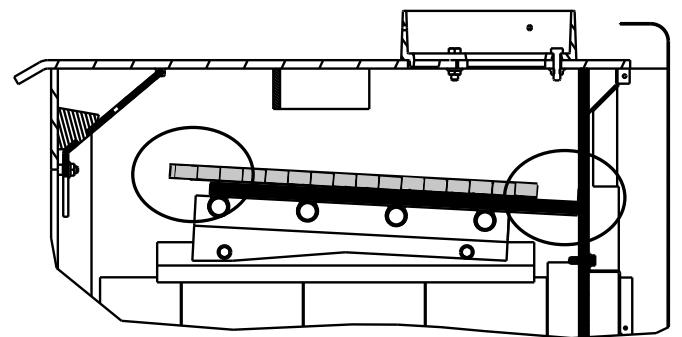

Figure 14.1

INCORRECT POSITIONS



Ceramic Blanket and Baffle Board are **NOT** in contact with the back of the firebox.



Ceramic Blanket is **NOT** in contact with the back of the firebox and **NOT** even with the Baffle Board in the front.

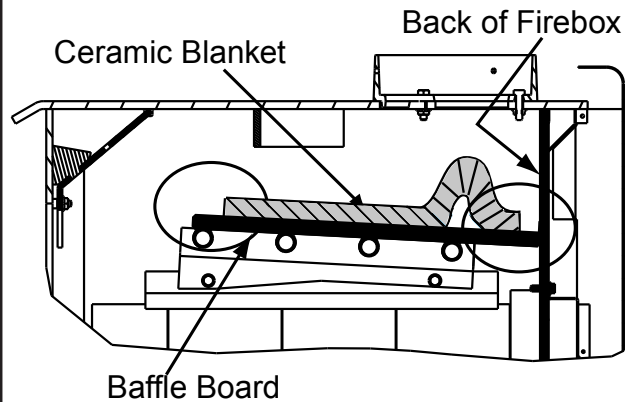

Ceramic Blanket is bunched up at the back of the firebox and **NOT** even with the Baffle Board in the front.

Figure 14.2

I. Blower Operating Instructions

NOTE: If your Quadra-Fire wood appliance is equipped with an optional blower, you should follow these guidelines:

1. Initial (cold) start-up and all Burn Settings

The blower can be plugged in and turned on right away. The blower fan is turned on and off by a snap disc. When your appliance has reached a certain temperature the blower will turn on and when your appliance has cooled down to a certain temperature it will turn off. Switch on blower control must be set to auto for this feature to work.

2. The blower is equipped with a speed control. Adjust the fan speed by turning the speed control clockwise to "Low" or counterclockwise to "High" (**Figure 15.2**).

3. Snap Disc Location

If you find the blower coming on and off at undesirable temperatures, relocate the snap disc to another location in the designated zone on the back of the appliance (**Figure 15.1**). There is a manual over-ride switch to deactivate the snap disc, if necessary.

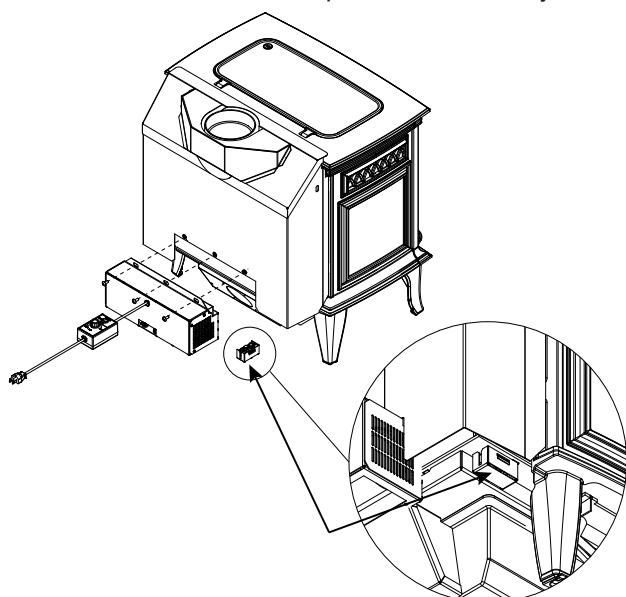

Figure 15.1

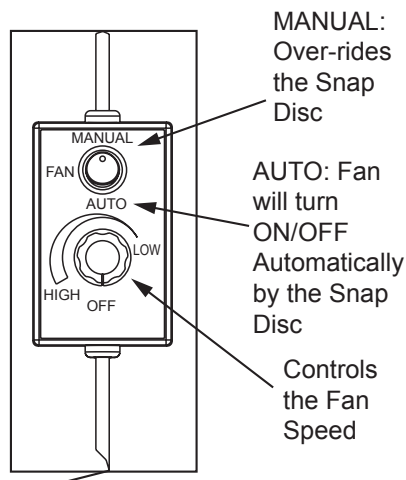

Figure 15.2

J. Opacity (Smoke)

This is the measure of how cleanly your appliance is burning. Opacity is measured in percent; 100% opacity is when an object is totally obscured by the smoke column from a chimney, and 0% opacity means that no smoke column can be seen. As you become familiar with your appliance, you should periodically check the opacity. This will allow you to know how to burn as nearly smoke-free as possible (goal of 0% opacity).

! WARNING

Fire Risk.



- DO NOT BURN GARBAGE OR FLAMMABLE FLUIDS SUCH AS GASOLINE, NAPHTHA OR ENGINE OIL.
- Do NOT burn treated wood or wood with salt (driftwood).
- May generate carbon monoxide if burn material other than wood.

May result in illness or possible death.

! WARNING

Fire Risk.



Keep combustible materials, gasoline and other flammable vapors and liquids clear of appliance.

- Do NOT store flammable materials in the appliance's vicinity.
- DO NOT USE GASOLINE, LANTERN FUEL, KEROSENE, CHARCOAL LIGHTER FLUID OR SIMILAR LIQUIDS TO START OR "FRESHEN UP" A FIRE IN THIS Appliance.
- Keep all such liquids well away from the appliance while it is in use.
- Combustible materials may ignite.

! CAUTION

When burning your first fire, you will experience smoke and odor from the appliance resulting from the curing of paint and burning off of any oils remaining from manufacturing.

OPEN WINDOWS DURING INITIAL BURN TO DISSIPATE SMOKE AND ODORS!

- Odors may be irritating to sensitive individuals.
- Smoke detectors may activate.

K. Clear Space

- Do NOT place combustible objects within 4 ft (1.2 m) of the front of appliance (**Figure 16.1**).
- Mantel - avoid placing candles and other heat-sensitive objects on mantel or hearth. Heat may damage these objects.

 WARNING
Do NOT place combustible objects in front of the appliance. High temperatures may ignite clothing, furniture or draperies.

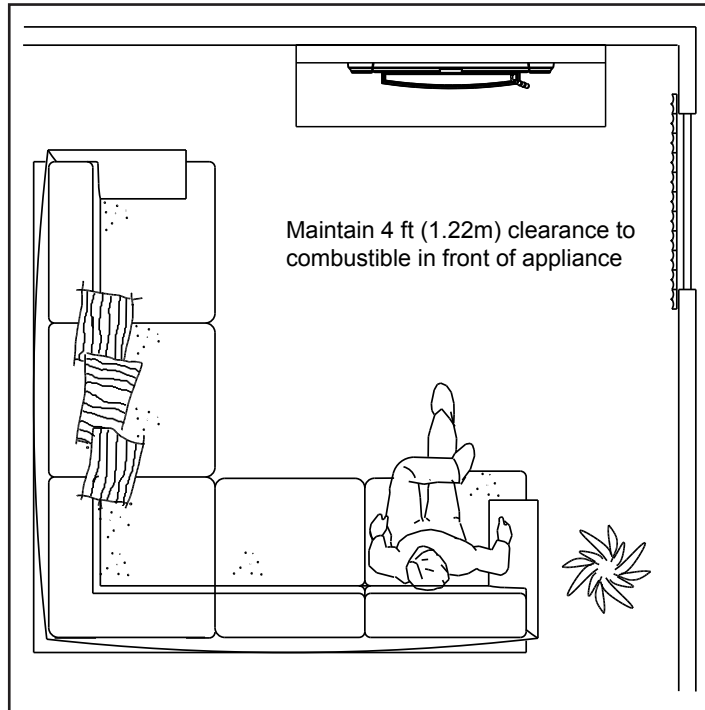



Figure 16.1

L. Negative Pressure

 WARNING
Asphyxiation Risk. <ul style="list-style-type: none"> • Negative pressure can cause spillage of combustion fumes, soot and carbon monoxide. • Appliance needs to draft properly for safety.

Negative pressure results from the imbalance of air available for the appliance to operate properly. It can be strongest in lower levels of the house.

Causes include:

- Exhaust fans (kitchen, bath, etc.)
- Range hoods
- Combustion air requirements for furnaces, water appliances and other combustion appliances
- Clothes dryers
- Location of return-air vents to furnace or air conditioning
- Imbalances of the HVAC air handling system
- Upper level air leaks such as:
 - Recessed lighting
 - Attic hatch
 - Duct leaks



To minimize the effects of negative air pressure:



- Install the outside air kit with the intake facing prevailing winds during the heating season
- Ensure adequate outdoor air for all combustion appliances and exhaust equipment
- Ensure furnace and air conditioning return vents are not located in the immediate vicinity of the appliance
- Avoid installing the appliance near doors, walkways or small isolated spaces
- Recessed lighting should be a “sealed can” design
- Attic hatches weather stripped or sealed
- Attic mounted duct work and air handler joints and seams taped or sealed

M. Frequently Asked Questions

ISSUES	SOLUTIONS
Odor from appliance	When first operated, this appliance may release an odor for the first several hours. This is caused by the curing of the paint and the burning off of any oils remaining from manufacturing.
Metallic noise	Noise is caused by metal expanding and contracting as it heats up and cools down, similar to the sound produced by a furnace or heating duct. This noise does not affect the operation or longevity of the appliance.
Whirring sound	If the optional blower has been installed, the blower produces a whirring sound which increases in volume as the speed is increased.

CONTACT YOUR DEALER for additional information regarding operation and troubleshooting.
 Visit www.quadrafire.com to find a dealer.

 WARNING	
	<p>Fire Risk.</p> <ul style="list-style-type: none"> • DO NOT BURN GARBAGE OR FLAMMABLE FLUIDS SUCH AS GASOLINE, NAPHTHA OR ENGINE OIL. • Do NOT burn treated wood or wood with salt (driftwood). • May generate carbon monoxide if burn material other than wood. <p>May result in illness or possible death.</p>

 WARNING	
	<p>Fire Risk.</p> <p>Keep combustible materials, gasoline and other flammable vapors and liquids clear of appliance.</p> <ul style="list-style-type: none"> • Do NOT store flammable materials in the appliance's vicinity. • DO NOT USE GASOLINE, LANTERN FUEL, KEROSENE, CHARCOAL LIGHTER FLUID OR SIMILAR LIQUIDS TO START OR "FRESHEN UP" A FIRE IN THIS APPLIANCE. • Keep all such liquids well away from the appliance while it is in use. • Combustible materials may ignite.

3 Maintenance and Service

A. Quick Reference Maintenance Guide

When properly maintained, your fireplace will give you many years of trouble-free service. Contact your dealer to answer questions regarding proper operation, troubleshooting and service for your appliance. Visit www.quadrafire.com/owner-resources to view basic troubleshooting, FAQs, use & care videos.

CAUTION! Allow the appliance to completely cool down before performing any cleaning or maintenance. Start the first inspection after the first 2 months of use, or if performance changes, and adjust your schedule accordingly. Maintenance is required for safe operation and must be performed to maintain your warranty.

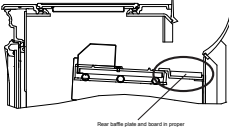
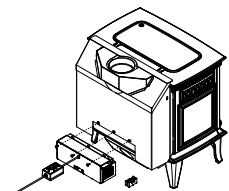
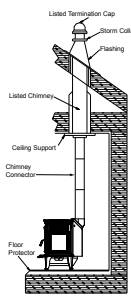
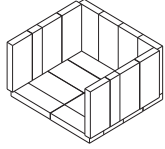
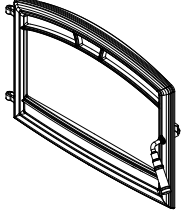
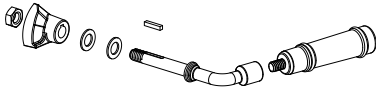
	Frequency	Task
<p>Baffle & Blanket</p> 	<p>MONTHLY or after every cord of wood</p>	<p>Baffle and blanket placement is critical to heat output, efficiency and overall life of the appliance. Make sure the baffle is pushed all of the way to the back of the firebox and the blanket is laying flat. Inspect baffle for cracks.</p>
<p>Optional Blower</p> 	<p>YEARLY or After Every 4 Cords of Wood</p>	<p>Vacuum the blower impellers.</p>
<p>Chimney System</p> 	<p>EVERY 2 MONTHS or After Every 4 Cords of Wood</p>	<p>The chimney and chimney cap must be inspected for soot and creosote every two months during the burn season or more frequency if chimney exceeds or is under 14-16 ft (4.3m-4.8m) measured from bottom of appliance.</p> <p>This will prevent pipe blockage, poor draft, and chimney fires.</p> <p>Always burn dry wood to help prevent cap blockage and creosote build-up.</p>
<p>Firebrick & Ash Removal</p> 	<p>WEEKLY or After Every 25 Loads of Wood</p>	<p>Ashes must be cool before you can dispose of the ashes in a non-combustible container.</p> <p>Firebrick is designed to protect your firebox. After ashes are removed, inspect the firebrick and replace firebricks that are crumbling, cracked or broken.</p>
<p>Door & Glass Assemblies</p> 	<p>WEEKLY or After Every 25 Loads of Wood</p>	<p>Keep door and glass gasket in good shape to maintain good burn times on a low burn setting. To test: place a dollar bill between the appliance and door and then shut the door. If you can pull the dollar out, remove one washer from door handle behind latch cam and try again. If you can still pull it out, replace the door gasket. Check the glass frame for loose screws to prevent air leakage. Check glass for cracks.</p>
<p>Door Handle</p> 	<p>WEEKLY or After Every 25 Loads of Wood</p>	<p>Check the door latch for proper adjustment. This is very important especially after the door rope has formed to the appliance face.</p> <p>Check door handle for smooth cam operation.</p>

These are generic drawings and may not represent your model.

B. General Maintenance

1. Creosote (Chimney) Cleaning

- **Frequency:** Every 2 months during heating season or as recommended by a certified chimney sweep; more frequently if chimney exceeds or is under 14-16 ft. (measured from bottom of appliance)
- **By:** Certified Chimney Sweep

Remove all ash from the firebox and extinguish all hot embers before disposal. Allow the appliance to cool completely. Disconnect flue pipe or remove baffle and ceramic blanket from appliance before cleaning chimney. Otherwise residue can pile up on top of the baffle and ceramic blanket and the appliance will not work properly. (See Baffle Removal on **page 23**). Close the door tightly. The creosote or soot should be removed with a brush specifically designed for the type of chimney in use. Clean out fallen ashes from the firebox.

It is also recommended that before each heating season the entire system be professionally inspected, cleaned and repaired if necessary.

Inspection: Inspect the system at the appliance connection and at the chimney top. Cooler surfaces tend to build creosote deposits quicker, so it is important to check the chimney from the top as well as from the bottom.

Formation and Need For Removal: When wood is burned slowly, it produces tar and other organic vapors which combine with expelled moisture to form creosote.

The creosote vapors condense in the relatively cool chimney flue of a newly-started or a slow-burning fire. As a result, creosote residue accumulates on the flue lining. When ignited, this creosote creates an extremely hot fire which may damage the chimney or even destroy the house.

The chimney connector and chimney should be inspected once every 2 months during the heating season to determine if a creosote or soot buildup has occurred. If creosote or soot has accumulated, it should be removed to reduce the risk of a chimney fire.

2. Ash Removal System (ARS) Operating and Cleaning

- **Frequency:** As necessary
 - **By:** Homeowner
1. The appliance and ashes must be completely cooled down before using the Ash Removal System. Reach down and locate the ash removal door handle under the left side of the appliance in the center. Grasp the handle with your fingers and place your thumb on the latch release (**Figure 19.1**). Press the latch release inward. Keep the latch release pressed in and lower the handle gently. Take your thumb off the release once the handle is clear of the latch and guide the handle back until it stops.
 2. Remove cast iron cap from inside the firebox using tools supplied. Clean ash down through the ash removal system channel into the drawer below.

Inspect the top of the ARS door to ensure all ash has been removed. You can rapidly move the ARS latch handle up and down to help remove any ash from the door. Use a small brush to clean off the top of the door if any ash remains.

Be sure to replace the cap before operating the appliance. It is recommended to leave 1/4 to 1/2 inch (6-13mm) of ash on the firebox floor to allow air to flow freely underneath wood.

3. Close the door handle, you will hear a “click” when it closes. **Wear gloves to remove the drawer.** Dispose of the ashes following the directions on **the next page.**

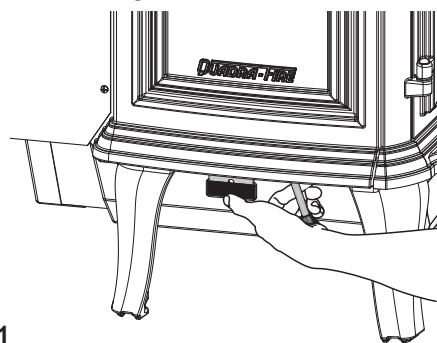

Figure 19.1

	WARNING
	<p>Fire Risk. Prevent creosote buildup.</p> <ul style="list-style-type: none"> • Inspect chimney connector and chimney once every two months during heating season. • Remove creosote to reduce risk of chimney fire. • Ignited creosote is extremely HOT.

	CAUTION
	<p>Injury Risk.</p> <ul style="list-style-type: none"> • Gloves recommended • May have sharp edges



	WARNING
	<p>Fire Risk.</p> <ul style="list-style-type: none"> • Do not use chimney cleaners or flame colorants in your appliance. Will corrode chimney pipe.

	WARNING
	<p>Fire Risk. Injury Risk. Make sure Ash Removal System door is sealed tight against the gasket.</p> <p>Air leakage may cause:</p> <ul style="list-style-type: none"> • Over-fire condition. • Flame and/or smoke spillage. • Wood to burn too fast.

3. Disposal of Ashes

- **Frequency:** When ash is within 1-3/4 in. (44mm) of firebox lip
- **By:** Homeowner

Ashes should be placed in a metal container with a tight fitting lid. The closed container of ashes should be placed on a non-combustible floor or on the ground, well away from all combustible materials, pending final disposal. If the ashes are disposed of by burial in soil or otherwise locally dispersed, they should be retained in the closed container until all cinders have thoroughly cooled.

 WARNING	
	<p>Fire Risk. Disposal of Ashes</p> <ul style="list-style-type: none">• Ashes should be placed in metal container with tight fitting lid.• Do not place metal container on combustible surface.• Ashes should be retained in closed container until all cinders have thoroughly cooled.

4. Glass Cleaning

- **Frequency:** As desired
- **By:** Homeowner

Clean glass with a non-abrasive glass cleaner. Abrasive cleaners may scratch and cause glass to crack. If the deposits on the glass are not very heavy, normal glass cleaners work well. Heavier deposits may be removed by using a damp cloth dipped in wood ashes or by using a commercially available oven cleaner.

After using an oven cleaner, it is advisable to remove any residue with a glass cleaner or soap and water. Oven cleaner left on during the next firing can permanently stain the glass and damage the finish on metal surfaces.

A portion of the combustion air entering the firebox is deflected down over the inside of the door glass. This air flow “washes” the glass, helping to keep smoke from adhering to its surface.

When operated at a low burn rate, less air will be flowing over the glass and the smokey, relatively cool condition of a low fire will cause the glass to become coated.

Operating the appliance with the Burn Rate Air Control and Start-Up Air Control all the way open for 30-45 minutes should remove the built up coating.

CAUTION	
<ul style="list-style-type: none">• Do not use polishes with abrasives. It will scratch surfaces.	

4 Troubleshooting Guide

With proper installation, operation, and maintenance your wood appliance will provide years of trouble-free service. If you do experience a problem, this troubleshooting guide will assist you or a qualified service person in the diagnosis of a problem and the corrective action to be taken.

Start Fire Problems	Possible Cause	Solution
Can not get fire started Excessive smoke or spillage Burns too slowly Not enough heat output	Not enough kindling/paper or no kindling/paper	Use dry kindling, more paper. Arrange kindling & wood for air movement.
	Not enough air for fire to ignite	Check for restricted termination cap
		Check for blockage of outside air kit (if installed).
		Check for flue blockage.
		Pre-warm flue before starting fire (refer to Building a Fire Section).
		Check for adequate vent height (refer to Chimney Height Section).
	Open window below the appliance towards the wind.	
	Wood condition is too wet, too large	Use dry, seasoned wood (refer to Seasoned Wood Section).
	Bed of coals not established before adding wood	Start with paper & kindling to establish bed of coals (refer to Building a Fire Section).
Flue blockage such as birds' nests or leaves in termination cap	Have chimney inspected for creosote and cleaned by a certified chimney sweep.	
Down draft or negative pressure Competition with exhaust devices	Do not use exhaust fans during start-up (refer to Negative Pressure Section).	
	Open window below the appliance towards the wind.	
Fire burns too fast	Extremely dry or soft wood	Mix in hardwood.
		Mix in less seasoned wood after fire is established (refer to Wood Fuel Section).
	Over drafting	Check for correct vent height; too much vertical height creates over drafting.
		Check location of vent termination (refer to Chimney Termination Requirement Section).

5 Service Part Replacement

A. Glass Replacement - Door Assembly

(Replace with 5mm ceramic glass only)

1. Ensure that the fire is out and the appliance is cool to the touch.
2. Protect a table or counter top with padding or towels. Protect your hands and wear gloves to prevent injury.
3. Remove the door with the broken glass by lifting the door up and off of the hinges.
4. Lay door face down on a table or counter making sure the handle hangs over the edge so the door lays flat, on a soft surface.
5. Remove the screws from each glass retainer and remove the glass. (If screws are difficult to remove, soak with penetrating oil first).
6. Center the glass with edges evenly overlapping the opening in the door, (i.e. same space top and bottom, left and right sides).
7. Replace the glass retainers. Be careful not to cross thread the screws.
8. Tighten each retainer just a few turns until each is secured. Check again for centering of glass in door frame. Continue to tighten each retainer alternately, a few turns at a time, until the glass is secure. **DO NOT OVER TIGHTEN** - can cause glass to break.
9. Replace the door on the appliance.

Quadra-Fire appliances are equipped with ceramic super heat-resistant glass, which can only be broken by impact or misuse.



WARNING



Injury Risk.

- Use only glass specified in manual.
- **DO NOT REPLACE** with any other material.

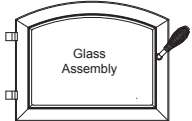
CAUTION!



Handle glass assembly with care.
When cleaning glass:

- Avoid striking, scratching or slamming glass.
- Do NOT clean glass when hot.
- Do NOT use abrasive cleaners.
- Use a hard water deposit glass cleaner on white film.
- Use commercial oven cleaner on heavier deposits.
- Remove all residue of oven cleaner or will permanently stain glass on next firing.

Refer to maintenance instructions.

B. Firebrick Replacement

Replace the firebrick if they become crumbly and/or if there is a 1/4 inch (6.35mm) gap between the bricks.

Inspect the firebrick after each ash removal.

The firebox is lined with high quality firebrick, which has exceptional insulating properties. There is no need to use a grate; simply build a fire on the firebox floor. Do not operate appliance without firebrick.

1. After the coals have completely cooled, remove all old brick and ash from appliance and vacuum firebox.
2. Remove new brick set from box and lay out to diagram shown.
3. Lay bottom bricks in appliance.
4. Install rear bricks on the top of the bottom bricks. Slide top of bricks under clip on back of firebox wall and push bottom of brick back.
5. Install side bricks. Slide top of brick under clips on side of firebox and push the bottom of the brick until it is flush with the side of the appliance.

C. Snap Disc Replacement

(Included with optional blower)

1. Locate the snap disc bracket assembly at the bottom left rear corner of the appliance.
2. A magnet holds the bracket to the appliance. Pull the bracket down away from the appliance to expose the snap disc.
3. Pull the snap disc and spade connectors up and out of bracket as shown in **Figure 22.1**
4. Using a Phillips head screw driver, remove the 2 screws from the snap disc and then remove the snap disc from the spade connectors. Replace with new snap disc and re-connect to spade connectors.
5. Push the snap disc and spade connectors back inside bracket and re-attach the bracket to the appliance.

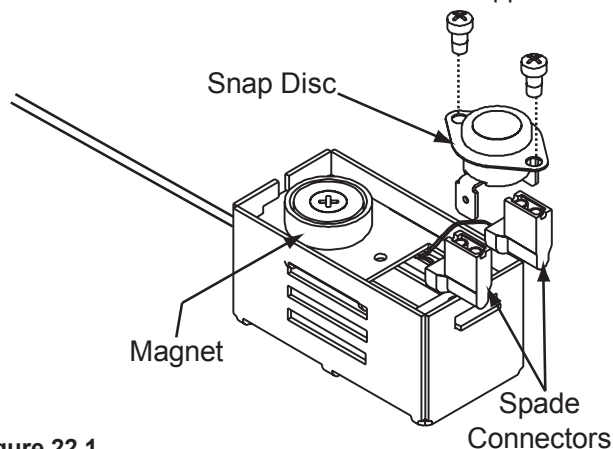

Figure 22.1

D. Door Handle Assembly

1. Slide door handle through door.
2. Install additional washer(s) as shown in **Figure 23.1**
3. Install key in groove.
4. Align groove in latch cam with key; slide latch cam over shaft
5. Install locknut but do not over tighten, the handle needs to rotate smoothly.
6. Install fiber handle (**Figure 23.1**).

! CAUTION

Do not over tighten lock nut. The door handle needs to move smoothly.

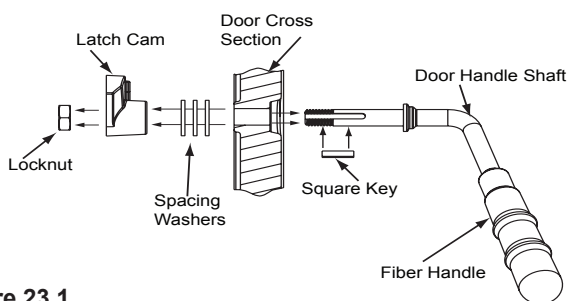

Figure 23.1

E. Baffle Removal

1. Remove all ash from the firebox and dispose appropriately.
2. Lift baffle protection channel, board, and blanket approximately 1 inch up so it is free from the front tube.
3. Pull baffle protection channel forward to remove.
4. Lift one half of the baffle board just above the other and slide over the top so it is centered in the appliance then tilt down to remove. Slide the second half of the baffle board to the center then tilt down to remove. The baffle blanket will come out with the second board.
5. Install baffle board in the reverse manner to which it was removed.
6. Install baffle blanket. It is easier to install the blanket by folding the two sides approximately 4 inches from the end then flattening them down once seated against the rear of the firebox.
7. Install baffle protection channel. This must sit correctly on the front air tube for the appliance to work as designed.

NOTE: Check to ensure the boards and blanket are situated appropriately.

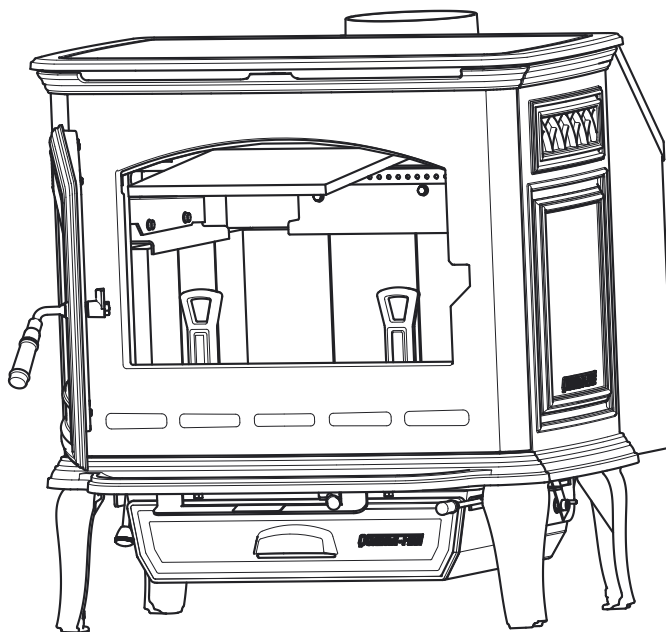

Figure 23.2

F. Tube Channel Assembly Replacement

Removing Tube Channel Assembly

1. Remove convection blower shroud (4 screws, 2 on each side).
2. Tilt shroud forward and slide up and away from appliance.
3. Remove right side casting.

CAUTION: Block up right side of appliance so the appliance is supported on the ash pan and not resting on the right side casting.

4. Remove the two flange nuts securing the side to the firebox.
5. Pull the side out and back.
6. Remove the baffle board and blanket.
7. Remove the tube channel assembly (It is recommended to soak the bolts with penetrating oil for at least 15 minutes before trying to remove them.).
8. Remove the two flange nuts.
9. Remove the two hex bolts.
10. Remove tube channel assembly.

NOTE: Service Space

In order to replace the tube channel assembly a clearance of 19 inches (483mm) is required on the right side of appliance in order to remove the tubes with the appliance in place.

If space is not available, the appliance will have to be disconnected from the chimney to proceed with the tube replacement.

Replacing Tube Channel Assembly

1. Install baffle board, blanket, and tube assembly.
2. Insert baffle blanket
3. Insert tube assembly 2/3 of the way into the firebox.
4. Place baffle boards on top of tube assembly and situate the boards and blanket so they seat correctly
5. Insert tube assembly fully into the tube channel supports on the left side of the firebox.
6. Install baffle protection channel.
7. Secure two hex bolts.
8. Secure two flange nuts.

CAUTION: Ensure baffle board, baffle protection channel, and blanket are installed correctly.

9. Install right side casting.
10. Insert guide plates into the front of the firebox.
11. Place casting over two bolts.
12. Secure with two flange nuts.
13. Remove support from under ash pan.
14. Install convection blower shroud.

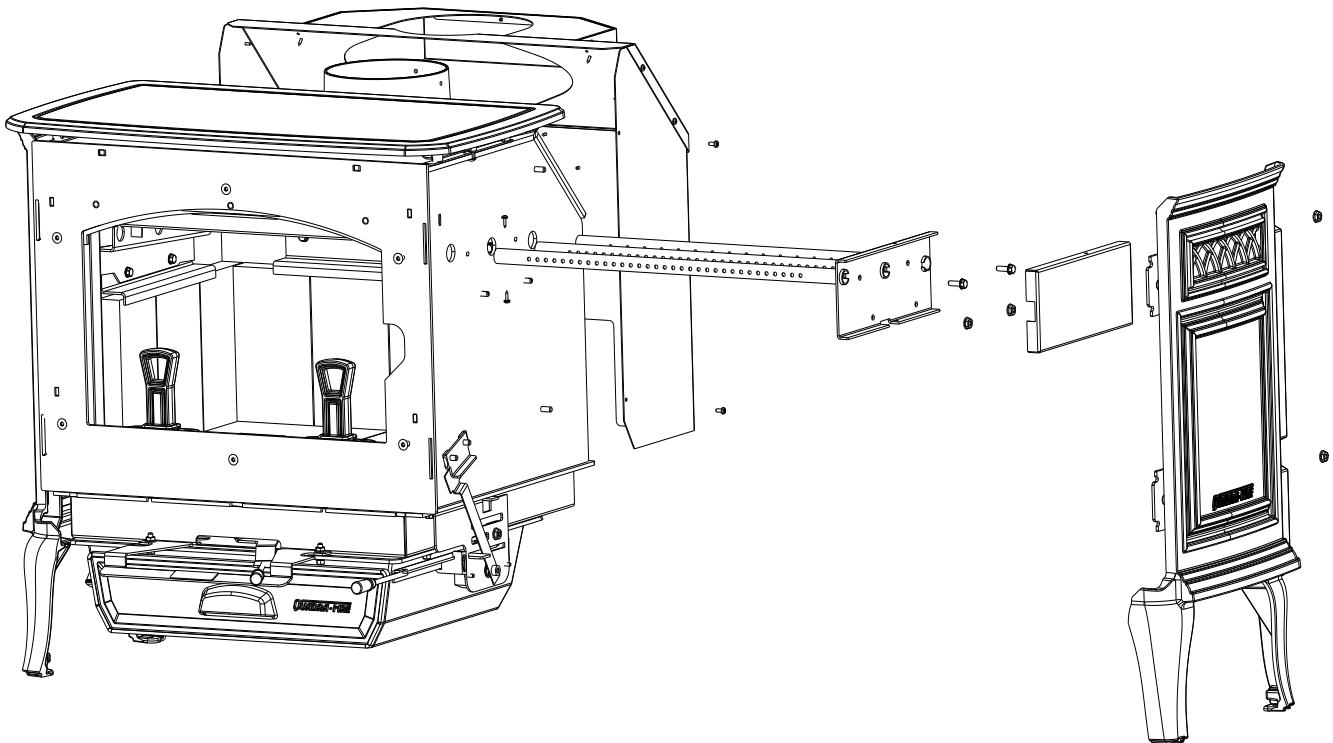

Figure 24.1

6 Reference Materials

A. Service & Maintenance Log

Date of Service	Performed By	Description of Service

Date of Service	Performed By	Description of Service

B. Expanded View

Wood Stove

Beginning Manufacturing Date: Nov 2015
Ending Manufacturing Date: Active

Color	SKU No.	Mfg. Dates
Matte Black	EXPLR-I-MBK	11/15-
Porcelain Black	EXPLR-I-PBK	11/15-
Porcelain Dark Blue	EXPLR-I-PDB	11/15-
Porcelain Frost	EXPLR-I-PFT	11/15-
Porcelain Mahogany	EXPLR-I-PMH	11/15-

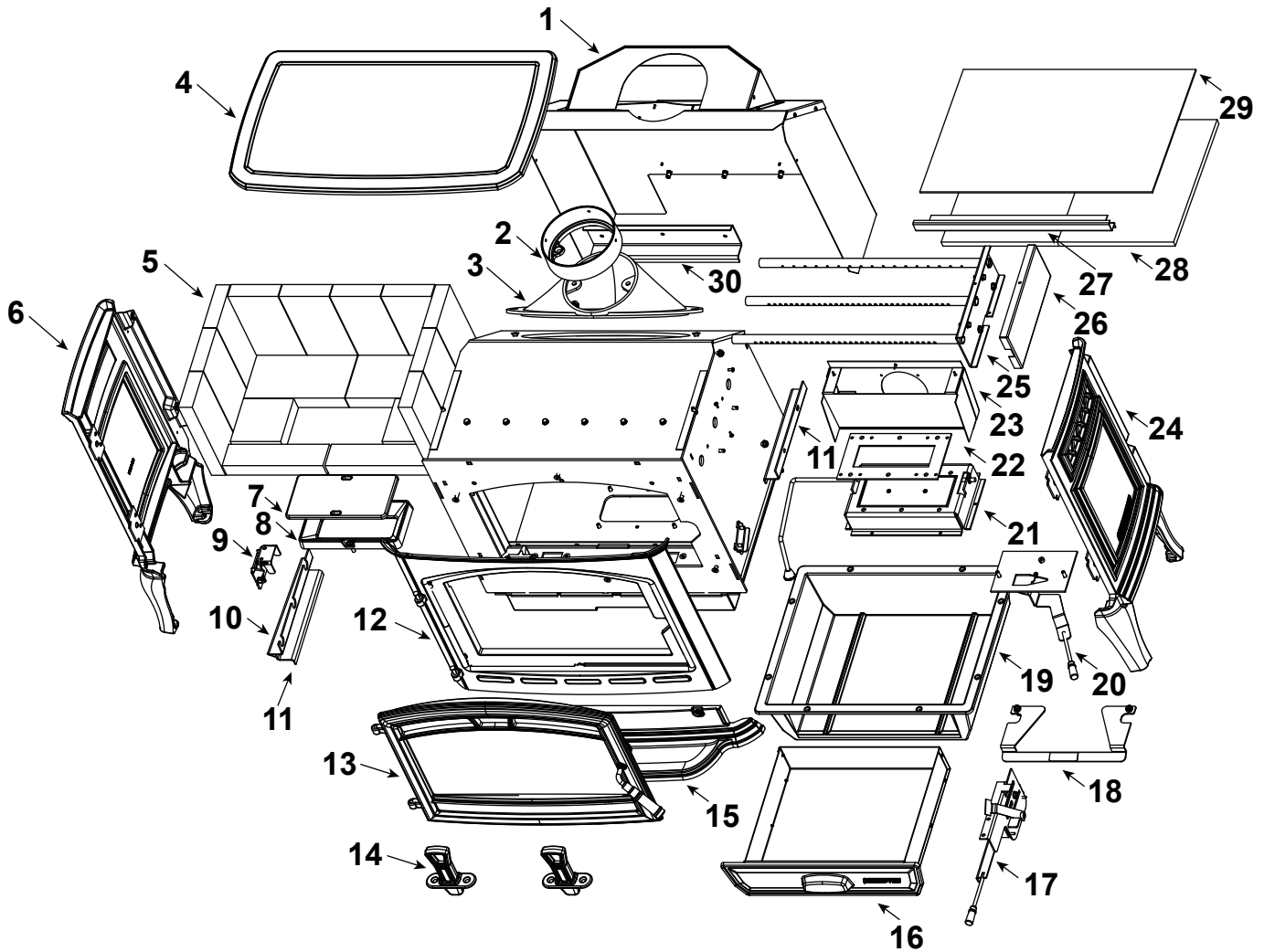

Part number list on following page.

08/18

C. Service Parts and Accessory List

Beginning Manufacturing Date: Nov 2015
Ending Manufacturing Date: Active

IMPORTANT: THIS IS DATED INFORMATION. Parts must be ordered from a dealer or distributor. **Hearth and Home Technologies does not sell directly to consumers.** Provide model number and serial number when requesting service parts from your dealer or distributor.



Stocked at Depot

ITEM	DESCRIPTION	COMMENTS	PART NUMBER
1	Rear Shroud Assembly		SRV7062-010
2	Flue Collar		SRV7061-201
3	Flue Transition Assembly		SRV29138
4	Top	Matte Black	7062-101MBK
		Porcelain Black	7062-101PBK
		Porcelain Blue	7062-101PDB
		Porcelain Frost	7062-101PFT
		Porcelain Mahogany	7062-101PMH

#5 Brick Assembly

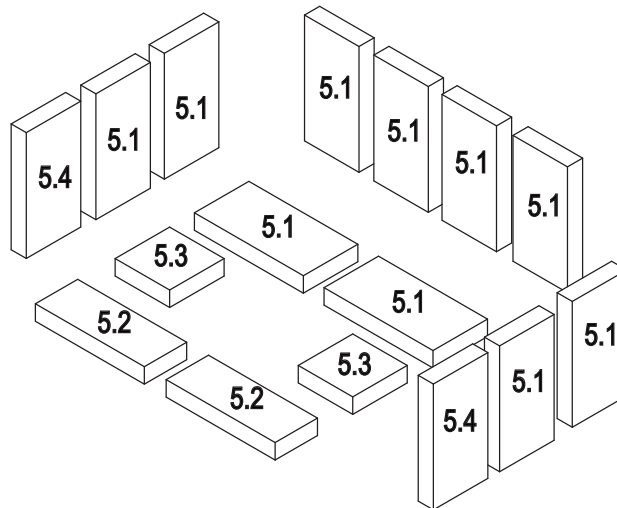

5	Brick Assembly		SRV7062-004
5.1	Brick #1, 9 X 4.5 X 1.25	Qty 10 req	
5.2	Brick #2, 9 x 2.5 x 1.25	Qty 2 req	
5.3	Brick #3, 4.5 x 4.5 x 1.25	Qty 2 req	
5.4	Brick #4, 9 X 3.75 X 1.25	Qty 2 req	
	Brick, Uncut (Must specify size when ordering)	Pkg of 1	832-0550
		Pkg of 6	832-3040
6	Side Left	Matte Black	7062-019MBK
		Porcelain Black	7062-019PBK
		Porcelain Blue	7062-019PDB
		Porcelain Frost	7062-019PFT
		Porcelain Mahogany	7062-019PMH
7	ARS Access Cover		SRV7038-196
8	ARS Channel		SRV7061-184
9	ARS Latch Assembly		SRV7062-034

Additional service part numbers appear on following page.

Beginning Manufacturing Date: Nov 2015
Ending Manufacturing Date: Active

IMPORTANT: THIS IS DATED INFORMATION. Parts must be ordered from a dealer or distributor. **Hearth and Home Technologies does not sell directly to consumers.** Provide model number and serial number when requesting service parts from your dealer or distributor.



Stocked at Depot

ITEM	DESCRIPTION	COMMENTS	PART NUMBER	
10	Tube Rack		SRV7062-139	
11	Side Brick Retainer		SRV7062-138	
12	Front	Matte Black	7062-103MBK	
		Porcelain Black	7062-103PBK	
		Porcelain Blue	7062-103PDB	
		Porcelain Frost	7062-103PFT	
		Porcelain Mahogany	7062-103PMH	
	Gasket 1/2"		7000-811	
13	Door Assembly	Matte Black	7062-003MBK	
		Porcelain Black	7062-003PBK	
		Porcelain Blue	7062-003PDB	
		Porcelain Frost	7062-003PFT	
		Porcelain Mahogany	7062-003PMH	

#13 Door Assembly

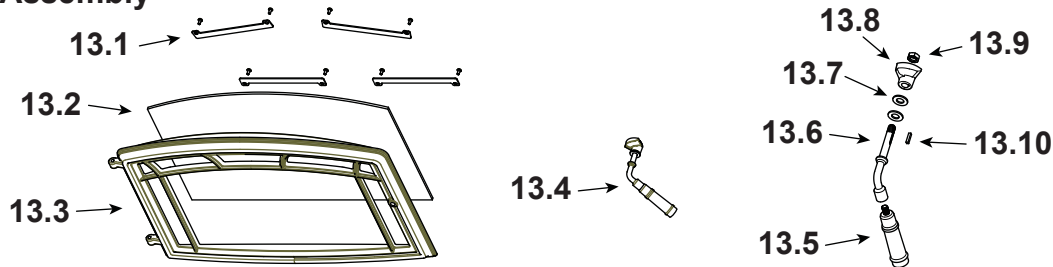

13.1	Glass Retainers		SRV7063-166	
13.2	Glass Assembly		SRV7062-013	Y
13.3	Door	Matte Black	7062-109MBK	
		Porcelain Black	7062-109PBK	
		Porcelain Blue	7062-109PDB	
		Porcelain Frost	7062-109PFT	
		Porcelain Mahogany	7062-109PMH	
13.4	Door Handle Assembly		SRV7063-014	Y
13.5	Fiber Handle		SRV7060-212	Y
13.6	Door Handle		SRV7063-137	
13.7	Washer, Sae, 3/8 (3 Ea)	Pkg of 3	832-0990	Y
13.8	Cam Latch		SRV430-1141	
13.9	Nut, 2Wy Side Lock Jam 3	Pkg of 24	226-0100/24	Y
13.10	Key, Cam Latch		SRV430-1151	
14	Andirons	2 Sets	SRV7061-020	

Additional service part numbers appear on following page.

IMPORTANT: THIS IS DATED INFORMATION. Parts must be ordered from a dealer or distributor. **Hearth and Home Technologies does not sell directly to consumers.** Provide model number and serial number when requesting service parts from your dealer or distributor.



Stocked at Depot

ITEM	DESCRIPTION	COMMENTS	PART NUMBER	
15	Ashlip	Matte Black	7062-113MBK	
		Porcelain Black	7062-113PBK	
		Porcelain Blue	7062-113PDB	
		Porcelain Frost	7062-113PFT	
		Porcelain Mahogany	7062-113PMH	
16	Ashpan		SRV7060-023	
17	Timer Assembly		SRV7062-025	
	Handle, Fiber		SRV7060-202	
	Timer (Only) Replacement Assembly		SRV480-1940	Y
18	Burn Rate Indicator		SRV7062-174	
19	ARS Box		SRV7060-005	
20	Burn Rate Control		SRV7062-023	
	Handle, Fiber		SRV7060-202	
21	ARS Assembly		SRV7062-035	
	Handle Cover, Access		SRV7038-197	
	Knob		SRV7000-343	
22	Gasket, ARS		SRV7033-296	Y
23	Outside Air Chamber		SRV7062-173	
24	Side Right	Matte Black	7062-018MBK	
		Porcelain Black	7062-018PBK	
		Porcelain Blue	7062-018PDB	
		Porcelain Frost	7062-018PFT	
		Porcelain Mahogany	7062-018PMH	
25	Tube Channel		SRV7062-017	Y
26	Tube Chanel cover		SRV7062-148	

#27 Baffle Protection Channel

Side view

Front, looking into unit →

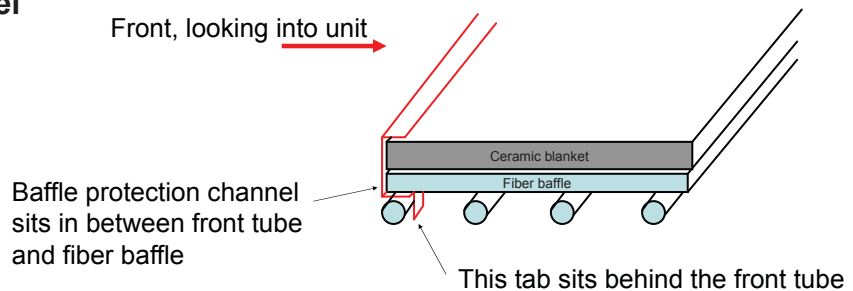

27	Baffle Protection Channel		SRV7062-149	Y
28	Baffle Board	2 pcs.	SRV7062-132	Y
29	Baffle Blanket		SRV7062-133	Y
30	Rear Brick Retainer		SRV7062-137	

Additional service part numbers appear on following page.

IMPORTANT: THIS IS DATED INFORMATION. Parts must be ordered from a dealer or distributor. **Hearth and Home Technologies does not sell directly to consumers.** Provide model number and serial number when requesting service parts from your dealer or distributor.



Stocked at Depot

ITEM	DESCRIPTION	COMMENTS	PART NUMBER	
	Component Pack (Includes Baffle Diverter and Instructions, 2 Leg Leveling Nuts & 2 Bolts, Touch-Up Paint, Owners Manual & Warranty Card)	Matte Black	SRV7062-027	
		Porcelain Black	SRV7062-028	
		Porcelain Blue	SRV7062-029	
		Porcelain Frost	SRV7062-030	
		Porcelain Mahogany	SRV7062-031	
	Leveling Assembly		7000-000	
	Paint Touch-Up	Matte Black	812-0910	
		Porcelain Black	1-00-0022	
		Porcelain Blue	1-00-0020	
		Porcelain Frost	1-00-0021	
		Porcelain Mahogany	855-1450	
ACCESSORIES				



CONTACT INFORMATION

Hearth & Home Technologies
352 Mountain House Road
Halifax, PA 17032
Division of HNI INDUSTRIES

**Please contact your Quadra-Fire dealer with any questions or concerns.
For the number of your nearest Quadra-Fire dealer
log onto www.quadrafire.com**

CAUTION



DO NOT DISCARD THIS MANUAL

Important operating and maintenance instructions included.

• Read, understand and follow these instructions for safe installation and operation.

• Leave this manual with party responsible for use and operation.



We recommend that you record the following pertinent information for your heating appliance.

Date purchased/installed: _____

Serial Number: _____ Location on appliance: _____

Dealership purchased from: _____ Dealer phone: 1(____) ____ - _____

Notes: _____

This product may be covered by one or more of the following patents: (United States) 5341794, 5263471, 6688302, 7216645, 7047962 or other U.S. and foreign patents pending.

