

CURVE Series Wood Appliances

Owner's Manual • Installation and Operation



HEAT & GLO™

No one builds a better fire
7076-108F • February 7, 2018

Congratulations

and Welcome to the Heat & Glo Family!

Hearth & Home Technologies welcomes you to our tradition of excellence! In choosing a Heat & Glo appliance, you have our assurance of commitment to quality, durability, and performance.

This commitment begins with our research of the market, including 'Voice of the Customer' contacts, ensuring we make products that will satisfy your needs. Our Research and Development facility then employs the world's most advanced technology to achieve the optimum operation of

our appliances, inserts and fireplaces. And yet we are old-fashioned when it comes to craftsmanship. Each appliance is meticulously fabricated and surfaces are hand-finished for lasting beauty and enjoyment. Our pledge to quality is completed as each model undergoes a quality control inspection.



We wish you and your family many years of enjoyment in the warmth and comfort of your hearth appliance. Thank you for choosing Heat & Glo.

Serial Rating Plate Example

Location: Back of Appliance

HEAT & GLO™

 NS-EN 13240

HEARTH & HOME
technologies
 20802 Kensington Blvd, Lakeville MN, 55044 - USA

CURVE 300S-HS WOOD STOVE

Nominal heat output: Nominell varmeeffekt:	8,7 KW
CO emission (at 13% O2): CO-utslipp (ved 13% O2):	0,18% 2262 mg/nm3
Efficiency: Effektivitet:	73,6%
Flue gas temperature: Røykgasstemperatur:	410° C
Dust CO emission (at 13% O2): Dust CO-utslipp (ved 13% O2):	14 mg/Nm3
Fuel Type: Drivstoff Type:	Wood
Safety clearance distance (back): Sikkerhetsavstand avstand (bak):	100 mm
Safety clearance distance (side): Sikkerhetsavstand avstand (side):	400 mm
Safety clearance distance (front): Sikkerhetsavstand avstand (foran):	1000 mm
Operation Type: Drift Type:	Intermittent Intermitterende
This appliance can be operated in a shared flue. Dette apparatet kan brukes i en delt røykkanal.	

Follow assembly and instructions manual. Følg montering og bruksanvisningen.
Use only recommended fuels. Bruk bare anbefalt brensel.

Country	Classification	Standard	Approved By
EUR	Intermittent	EN 13240	KVBG (2013)
Norway	Klasse 2	NS3058, NS3059	RISEFR 110-0392

SERIAL NO. / NUMÉRO DE SÉRIE / SERIENUMMER
 US041 room for .14 x .875" S/N

1.5" x .375 Barcode Label

2018 2019 2020 JAN FEB MAR APR MAY JUN JUL AUG SEP OCT NOV DEC

EU Energy Label



ENERG

Y

IJA

IE

IA

 CURVE 100S-HS,
 CURVE 300S-HS, and CURVE 300G-HS

A++

A+

A

B

C

D

E

F

G

A

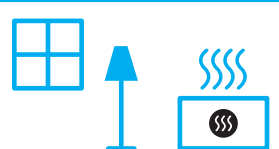

8,7

kW

ENERGIA · ЕНЕРГИЯ · ΕΝΕΡΓΕΙΑ · ENERGIJA · ENERGY · ENERGIE · ENERGI

2015/1186
7076-208B

Safety Alert Key:

- **DANGER!** Indicates a hazardous situation which, if not avoided will result in death or serious injury.
- **WARNING!** Indicates a hazardous situation which, if not avoided may result in death or serious injury.
- **CAUTION!** Indicates a hazardous situation which, if not avoided, may result in minor or moderate injury.
- **NOTICE:** Indicates practices which may cause damage to the appliance or to property.

TABLE OF CONTENTS

<p>1 Technical Data4</p> <p style="padding-left: 20px;">A. Installation.....4</p> <p style="padding-left: 20px;">B. Safety.....4</p> <p style="padding-left: 20px;">C. Type plates.....4</p> <p>2 Installation & Assembly5</p> <p style="padding-left: 20px;">A. Positioning Your Wood Burning Appliance.....5</p> <p style="padding-left: 20px;">B. Vertical Venting & Combustion Air.....5</p> <p style="padding-left: 20px;">C. Horizontal Venting5</p> <p style="padding-left: 20px;">D. Leveling the Appliance6</p> <p style="padding-left: 20px;">E. Position Near to Non-flammable Walls6</p> <p style="padding-left: 20px;">F. Distance to Furniture: 1000 mm.....6</p> <p style="padding-left: 20px;">G. Distance to Flammable Walls.....6</p> <p style="padding-left: 20px;">H. Component Pack6</p> <p style="padding-left: 20px;">I. Removal of Curve from Pallet.....6</p> <p>3 Dimensions & Clearances7</p> <p>4 Operation.....9</p> <p style="padding-left: 20px;">A. General Use.....9</p> <p style="padding-left: 20px;">B. Lighting Instructions.....9</p> <p style="padding-left: 20px;">C. Your First Fire.....9</p> <p style="padding-left: 20px;">D. Fuels.....9</p> <p style="padding-left: 20px;">E. Primary Air.....11</p> <p style="padding-left: 20px;">F. Upper Air Control11</p> <p style="padding-left: 20px;">G. Secondary Air.....11</p> <p style="padding-left: 20px;">H. Air wash System.....11</p> <p style="padding-left: 20px;">I. Side Door Handle Operation12</p> <p style="padding-left: 20px;">J. Front Door Seal.....12</p>	<p>5 Chimney Systems.....13</p> <p style="padding-left: 20px;">A. Chimney Systems.....13</p> <p style="padding-left: 20px;">B. Drafting13</p> <p>6 Maintenance.....14</p> <p style="padding-left: 20px;">A. Ash Drawer.....14</p> <p style="padding-left: 20px;">B. Refractory14</p> <p style="padding-left: 20px;">C. Baffle Material.....14</p> <p style="padding-left: 20px;">D. Proper Burn14</p> <p style="padding-left: 20px;">E. Coated Surfaces.....14</p> <p style="padding-left: 20px;">F. Cleaning the Glass.....14</p> <p>7 Troubleshooting15</p> <p>8 Warranty16</p> <p>9 Service Parts List17</p> <p>10 Homeowner Notes21</p>
--	---

1 Technical Data



No one builds a better fire

Curve Series Wood Appliances

CURVE-100S-HS

CURVE-300S-HS and CURVE-300G-HS

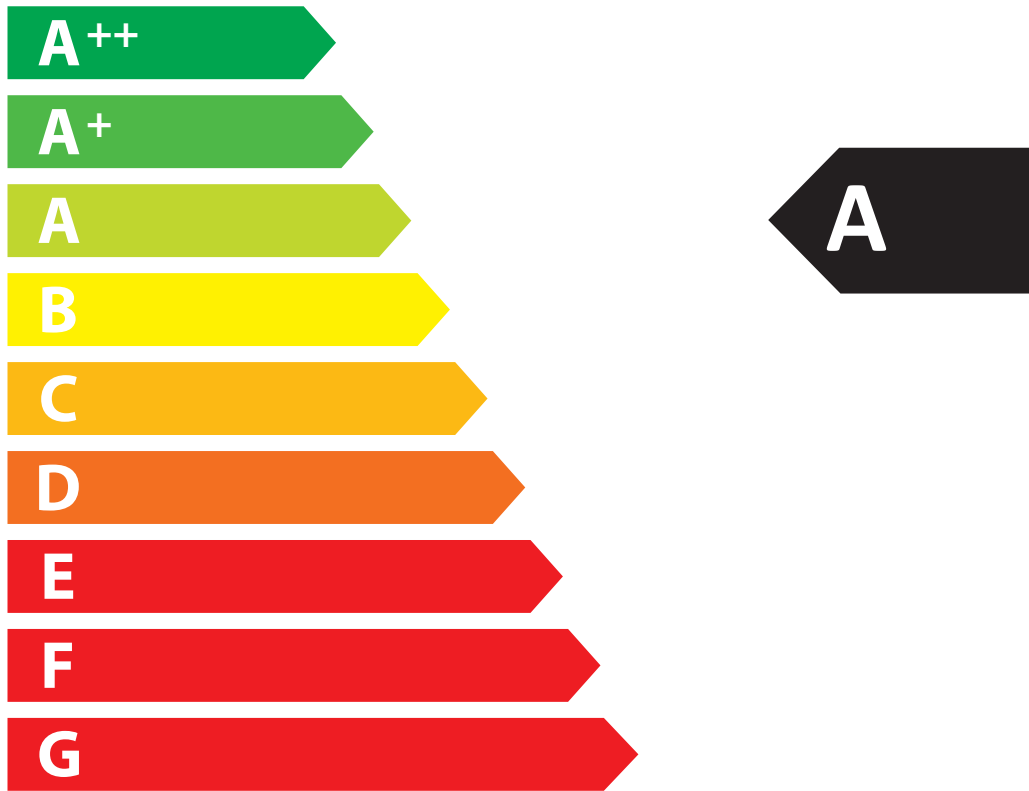

Energy Efficiency Class:	A
Direct Heat Output:	8,7 kW
Energy Efficiency Index:	96.72
Energy Efficiency at Nominal:	73,6%
Energy Efficiency at Minimum:	N.A.

A. Installation

The house owner is responsible for ensuring that all necessary national and local safety measures are observed during installation and fitting and also responsible for observing the fitting and operating instructions detailed in this manual.

When you install any kind of fireplace or appliance, you must inform the local authorities. You are also responsible for calling in a chimney sweep to inspect and authorize the installation.

To ensure best-possible functionality and safety for your installation, we advise you to call a professional fitter. Our Hearth and Home Dealer will be able to recommend a qualified fitter in your area. For information on Hearth and Home Dealers, please go to www.hearthnhome.com.

As a reminder, all local regulations, including those referring to national and European Standards need to be complied with when installing the appliance.

B. Safety

Any changes made to the product by the dealer, installer or user could result in the product and safety functions not functioning as intended. The same applies to the fitting of accessories or extra equipment not supplied by Hearth and Home. This could also be the case if parts that are necessary for the operation and safety of the appliance are dismantled or removed.

External surfaces of the appliance get hot during use and can cause burns. Use caution around the appliance even when the appliance does not appear to be in use. Different materials can hold heat for different lengths of time.

In the event of a chimney fire, keep the front door closed, close all air controls, evacuate the structure and call the local authorities from a safe location.

C. Type plates

All Heat & Glo wood-burning appliances are fitted with a serial plate, that specifies the approval standards and the distance to flammable materials.

Technical data and dimensions

Materials:	steel plate, cast iron, galvanized sheet, skamol
Maximum Wood Length	25 cm
Weight Curve 100	ca. 98 kg
Weight Curve 300	ca. 96 kg
Weight Heat-Accumulating Stones	ca. 86,5 kg
Connecting Piece Internal Diameter	135 mm
Connecting Piece External Diameter	148 mm
Approval Type	Intermittent Fuelling

Test in compliance with NS-EN 13240

Basic data for the Curve - series

CO Emission at 13% O ₂	0.18%	2262 mg/Nm ³
Dust @ 13% O ₂		14 mg/Nm ³
Nox @ 13% O ₂		70 mg/Nm ³
Nominal output		8.7 kW
Amount of smoke		5.6 g/s
Sub-pressure NS-EN 13240		11.8 Pa
Recommended sub-pressure in connecting piece		14-20 Pa
Required combustion air supply		15.5 Nm ³ /h
Fuel		Wood
Fuel consumption		2.68 kg/h
Amount of fuel		2.10 kg

Curve 100

Efficiency	74%
Chimney temperature NS-EN 13240	410°C
Temperature in connecting piece	410 °C

Curve 300

Efficiency	74%
Chimney temperature NS-EN 13240	410°C
Temperature in connecting piece	410°C

Intermittent fuelling means normal use of a wood appliance. In other words, you should let the fire die down until only the embers are left, before refuelling.

The EC declaration of conformity is available from:

www.hearthnhome.com

Note: Be aware of the use of exhaust fans when operating in the same room or space as the appliance, which could affect the draft of the appliance.

2 Installation & Assembly

A. Positioning Your Wood Burning Appliance

The wood burning appliance must be set up so the appliance, flue connection, flue pipe, and chimney system can be cleaned and serviced. Consideration should also be made when locating the appliance in the home due to the supply of combustion air requirements. Depending on the chosen installation method, supplied combustion air may be taken from the outside using the adapters provided, or through the back of the appliance by removing the cover plate on the inlet hole. (To remove the cover or install the outside air adapter, remove the back panel. The cover plate is located near the bottom and retained with four screws).

Out of the box, the appliance without the additional weight of the venting system or fuel load weighs nearly 100 kilograms. Make considerations for the weight of the system when locating the appliance in the desired location. If the load bearing characteristics of the structure are difficult to determine or there is concern that the structure will not adequately support the system, a distribution plate should be used. Contact your Radius Wood Appliance dealer with questions.

B. Vertical Venting & Combustion Air

When venting the appliance vertically, follow the venting manufacturer's instructions and requirements. Slip the cover ring down the flue and set on top of the appliance.

Vertical Venting Options (Fig. 5.1)

Standard 150 mm Venting: E, B, F

Coaxial venting: F, E, D, A

(Use the items indicated for your installation. Use the bolts provided to attach the components in the order shown.)

When installing F:

- If installing outside combustion air, turn F to cover the opening at the top of the combustion air plenum.
- If using room combustion air or coaxial venting, turn F to leave the opening at the top of the combustion air plenum open.

(The outside air connection is located on the lower back of the appliance. The 75 mm adapter is included in the component pack.)

C. Horizontal Venting

When venting the appliance horizontally, remove the back panel of the appliance. Next, remove the cast flue attachment ring in the top of the appliance by removing the four bolts used to secure it in shipping. Remove the rear cover plate that can be seen in the back of the appliance once the back panel is removed. Install the rear cover plate over the vertical outlet hole in the top of the appliance using the four bolts that were used to secure the cover plate when installed on the rear of the appliance. Install the cast flue attachment ring on the rear of appliance using four

bolts. Knock out the panel on the back panel so the flue attachment ring can slip through it. Attach the back panel back onto the appliance using the same fasteners. Install the venting per the venting manufacturer's specifications. Place the top cover plate (item "C" in Fig. 5.1) from the component pack over the hole in the top of the appliance for a finished look.

This appliance is suitable for installation in a shared flue.

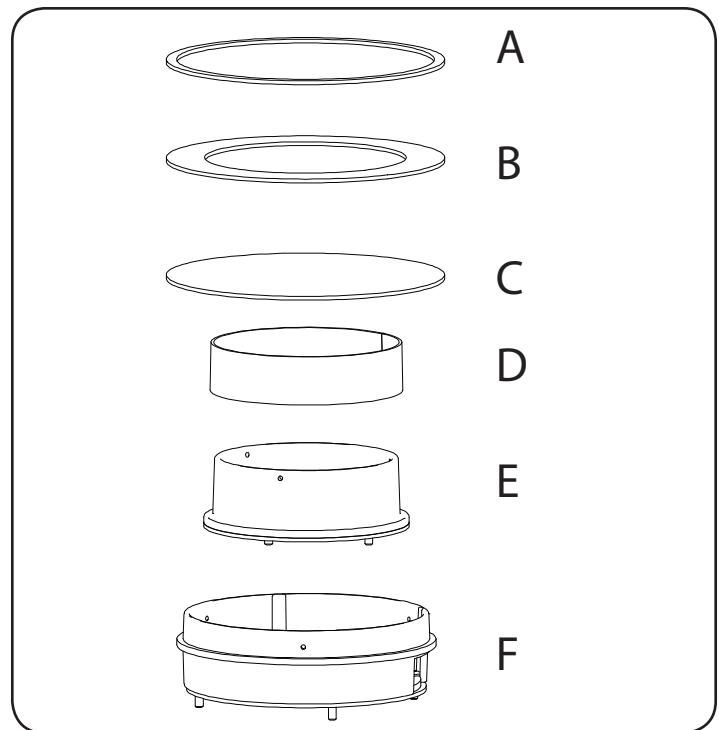

Fig. 5.1

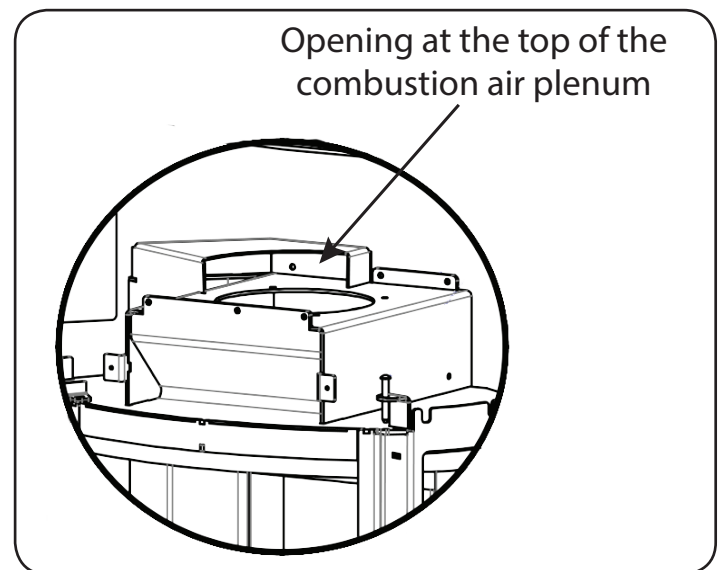

Fig. 5.2

D. Leveling the Appliance

Four leveling bolts have come installed on the appliance. Following installation, adjustments can be made to the heights of the four bolts from the top of the base pan. Use a hex head bit to adjust the height of each of the four legs. When in its final state, the appliance should be secure and not rock.

E. Position Near to Non-flammable Walls

When positioning near a non-flammable wall, we recommend you keep a minimum distance of 50 mm between the rear of the product and the wall for cleaning purposes.

F. Distance to Furniture: 1000 mm

But please check to avoid furniture or other furnishings being dried out due to being too close to the appliance.

RISEFR evaluation of safety distances						
	Combustible wall		Brick wall		Combustible wall	
	x (mm)	y (mm)	x (mm)	y (mm)	z (mm)	z (mm)
Curve 100 with internal shield installed	200	100	50	50	150	50

Fig. 6.1 Curve 100

G. Distance to Flammable Walls

RISEFR evaluation of safety distances						
	Combustible wall		Brick wall		Combustible wall	
	x (mm)	y (mm)	x (mm)	y (mm)	z (mm)	z (mm)
Curve 300 with internal shield installed	400	100	100	50	300	100

Fig. 6.2 Curve 300

H. Component Pack

The component pack contains the following:

- Manual
- Gloves
- Outside air connecting plate
- Top adapter ring
- Top flue cover plate
- Outside air screen

I. Removal of Curve from Pallet

1. Remove the two 11 mm bolts holding the brackets in the front and rear of the base on the appliance, this requires holding the bolt on the bottom side of the pallet as shown in picture below on right
2. Tilt appliance back appliance the front bracket is able to tilt forward and be removed from bottom of appliance, repeat tilting forward and removing rear bracket. (the brackets need to swing down and slightly back in order to be pulled from appliance)
3. Appliance can now be moved off pallet.

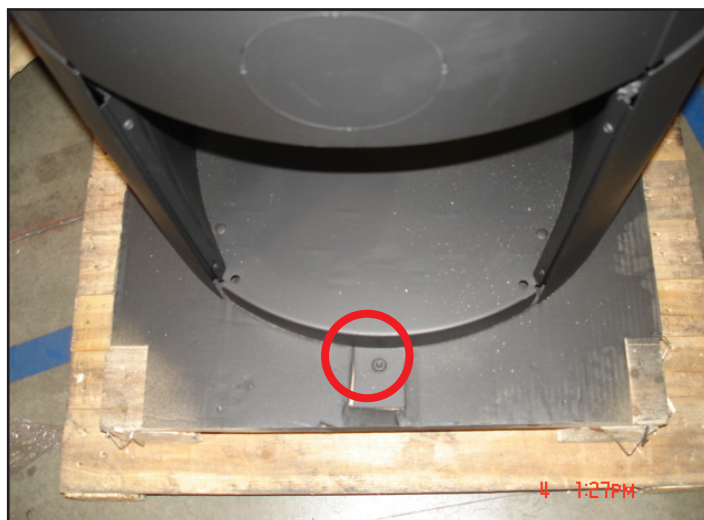

Fig. 6.2



Fig. 6.3

3 Dimensions & Clearances

Curve 100

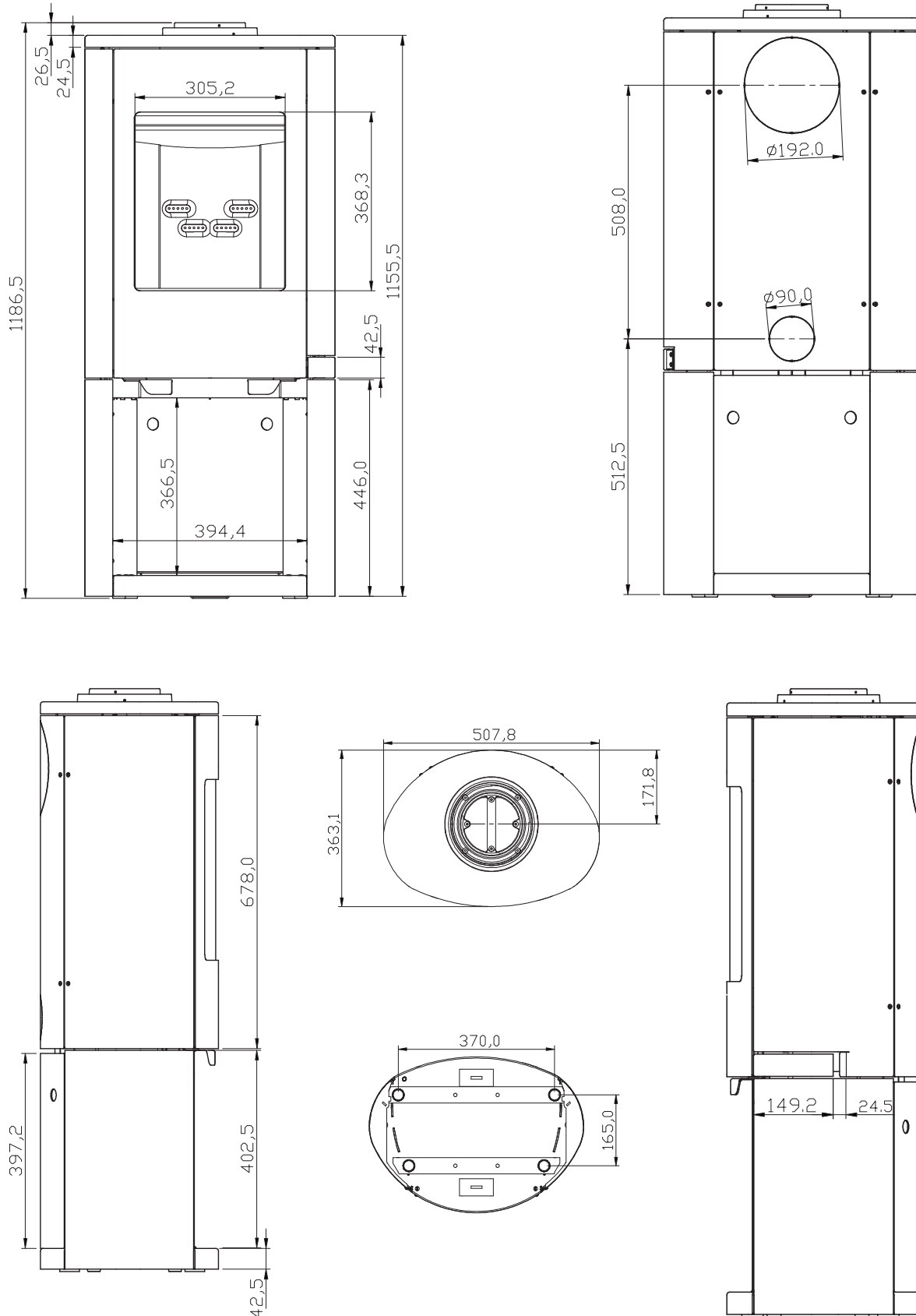

Curve 300

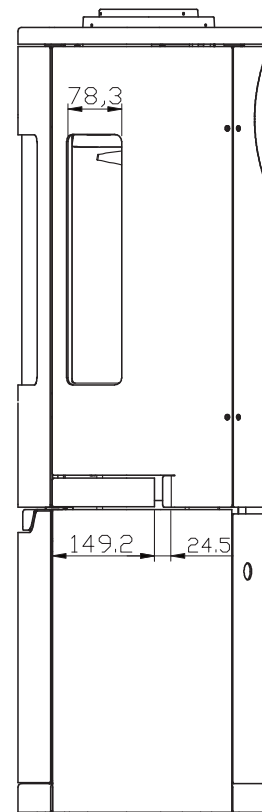
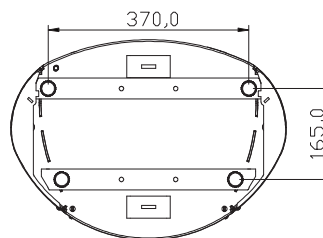
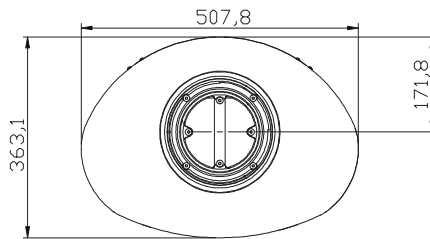
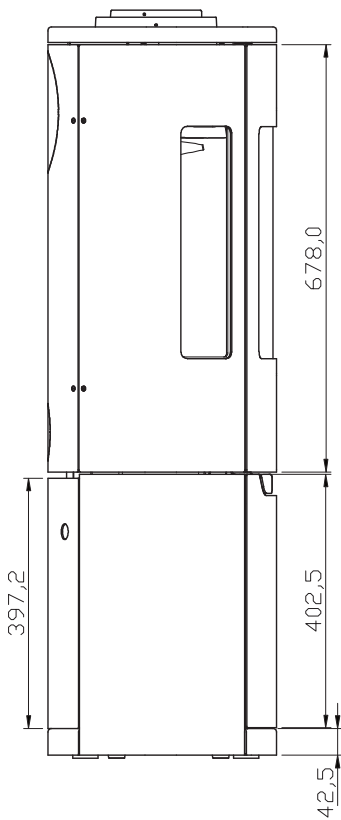
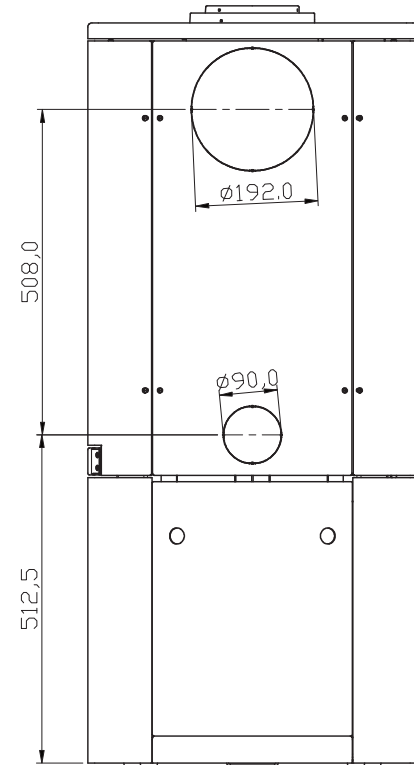
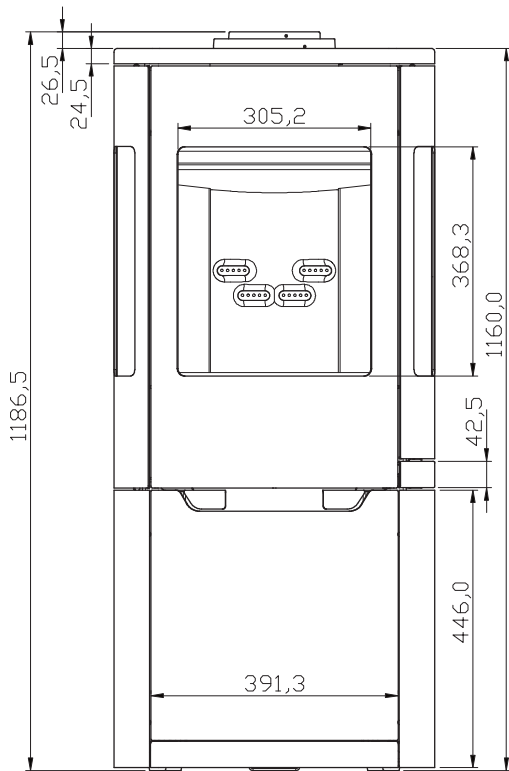

4 Operation

A. General Use

The Curve 100 Wood Appliance is designed and tested for intermittent use. This means that it is not designed for or recommended to burn continuously for 24 hours.

This is a wood burning appliance, the front, sides, and top will get hot. Please use caution when you are near the fire especially when it is burning.

Disposal of ashes and coals should always be in a non-combustible container. Never put coals or embers into a flammable container, even when they do not appear to be hot. Coals can hold heat for extended periods of time and may cause damage if improperly disposed of.

Prior to the start of the burn season or following extended periods of non-use, you should inspect the firebox, flue connections, and chimney system for debris and obstructions. Clean as necessary. Contact your chimney sweep if needed.

Modification to your Curve appliance is prohibited, will void the warranty, and may cause unsafe conditions during use. Certain accessories are approved and available from your local Curve Wood Appliance Dealer.

Use only approved replacement parts available from your Curve Wood Appliance Dealer.

B. Lighting Instructions

Use paper or lighting briquettes and small pieces of wood to light fire. Place the paper first in the bottom of the fire box and stack the lighting briquettes or small pieces of wood on top of the paper. Do not fill the firebox higher than the holes in the rear of the fire box. (Fig. 10.1).

Light the paper and leave the door open slightly. As the small pieces of wood are burning add slightly larger fuel on top of burning and fuel. Pull both air controls out and close the door. After 15-30 minutes or when good fire is established, close the lower air control (it is located on the left side) by pushing it in completely. When loading more wood during use, this control may need to be pulled out to add more air under the fire.

C. Your First Fire

During the first firing of the Curve it is to be expected to smoke and give off unpleasant fumes. This is caused by the paint curing on the coated surfaces. Make sure the room is well ventilated to reduce the inhalation of these fumes. After this first fire the smoking and unpleasant smell should greatly diminish.

As the paint cures, the rope seal on the door may stick to the face making it difficult to open the front door. To aid in the curing process, open the front door every 5 – 10 minutes for the first one to two hours. This will keep the seal from forming a bond to the face as the coating cures completely.

For the duration of this fire keep both air controls in the completely open position to ensure hot burn to cure appliance.

D. Fuels

The Curve 100 wood appliance is designed to burn a wide range of firewood species. In general hardwoods are better for heating since they burn more evenly. When operating the appliance with different types of fuels, refer to operating the wood appliance section for more information. Consult the internet for specific heating values of different species of firewood.

The optimal size of firewood for the Curve 100 wood appliance is 25 cm long and 6 cm – 12 cm in diameter when split. Some varieties of fuels may perform better when split smaller. When establishing a fire, it is helpful to have a variety of different diameters in order to heat the flue up quickly and establish the draft.

Fuels should be stored in locations protected from rain and excessive moisture. Well seasoned firewood may take 1-2 years to dry out. Well ventilated areas protected from environmental elements aid in preparing the fuel faster. If the fuel is stored outside, it is recommended that it is stored inside a few days before use to allow the fuel to warm up to room temperature.

Firewood and combustible items should **NEVER** be stored below the firebox. Make sure the proper clearance to flammable materials is maintained for all fuel storage.

The firewood used should have a moisture level less than 20%. The Curve 100 wood appliance will yield its best performance if the moisture content is between 15% and 18%. Moisture levels above 20% can have adverse environmental effects because of the inefficient burn. Moisture levels below 15% will burn faster resulting in shorter burn times. To determine whether your fuel is too wet, knock it on a hard surface. If it is too wet, the sound produced will be dull.

Burning wet wood reduces the amount of heat output into your home because it is turning the water into steam and venting it out your chimney rather than producing gases that are burned up in the secondary system. It also increases the amount of soot on the glass and in the chimney system. It is inefficient and produces pollution.

Improper use including the use of illegal fuels may cause pollution and can damage the appliance. Improper use will void the manufacturer's warranty. Never burn treated or painted wood, chipboard, glued or laminated materials, wood from salt water, plastics, trash, or chemically treated paper.



Lower intake holes

Add paper to back of firepot making sure to not block lower air inlet with paper



Add small pieces of wood on top of paper allowing for air flow between pieces



Secondary Holes

Add larger log on top of pile making sure it does not go above the upper intake holes

Fig. 10.1

E. Primary Air

(Lower Air Control) (Fig. 11.1)

The primary air is controlled by the lever on the left side of the appliance. When the control arm is pushed in, less air is allowed into the firebox below the fire. When the control arm is pulled out, maximum air is allowed in under the fire. This lever is to be used during start up and refueling. If this air control remains open (pulled out) then you will have reduced burn times or a potential to overheat the appliance.

F. Upper Air Control

(Fig. 11.1)

The upper air control is controlled by the lever on the right side of the appliance. When the control arm is pushed in, less air is allowed into the firebox through this system. When the control arm is pulled out, maximum air is allowed through the system. The function of this air control is to regulate the burn rate of the fire and provide air for the air wash system to keep the front glass (also side glass for the Curve 300 series) clean.

When the upper air control is closed and air is reduced to the air wash system, the glass will soot up. This is normal and to be expected. To help clean the glass off, add additional fuel to the fire, pull out the upper air control and pull out the lower air control lever for 15-30 minutes to establish a hot fire. A hot fire with the upper air control open will aid in cleaning the glass.

G. Secondary Air

This appliance is equipped with a secondary combustion system that cannot be regulated. The purpose of this secondary system is to provide air that will mix with the combustion gasses and burn them. This reduces the amount of debris and gasses being let out into the environment ensuring a clean burn.

H. Air wash System

An air wash system is built into the appliance and is controlled by the upper air control on the right side of the appliance. For models with three glass panes, each one has a dedicated orifice for the air wash system. Even with this air wash system, the glass panes will get dirty and have build up. This is normal and can be cleaned using a simple glass cleaner. Alternate glass cleaning products specifically designed for cleaning glass panes on wood burning appliances may be available from your dealer. Contact them directly for product availability.

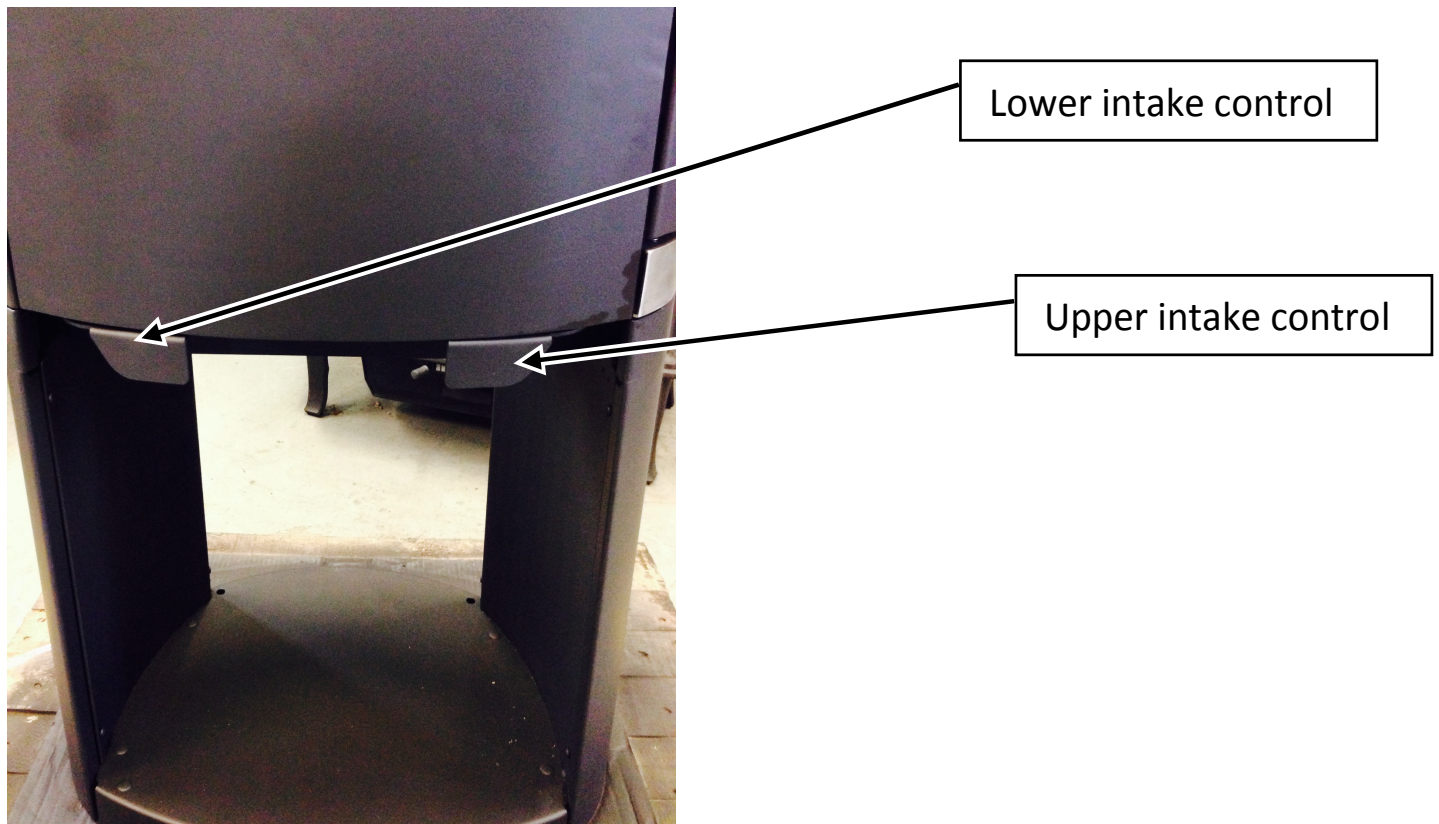

Fig. 11.1: Air Control

I. Side Door Handle Operation

(Fig. 12.1)

To open the front door, pull the lever located on the blower right side of the appliance (be sure to wear the glove provided if the appliance is hot). Carefully swing the door open from right to left. To close the door swing it shut from left to right and close by pushing the handle from front to back. When securing the front door closed, make sure both the top and bottom hooks engage the pins on the right side of the door.

J. Front Door Seal

The front door has a non-combustible rope which creates a tight seal for the firebox. The first time you open the front door and close it, the gasket may be stiff and the door difficult to close.

Following the first fire, the gasket will relax which will allow the door to be closed easily for normal use which provides a tight seal. This seal is critical for proper air regulation in the firebox for safe and efficient burn. Though

this material is a high quality material specifically designed for wood burning appliances, it is subject to normal wear and tear and should be replaced if burn times are reduced or there is concern of leakage.

The seal is subject to damage from excessive cleaning or by debris being closed in the door. If there is a concern of leakage, use a thin piece of paper, place against the gasket in the area of concern, close the door and latch shut, then gently tug on the paper. If the paper comes right out without any resistance, the seal should be replaced.



Fig. 12.1: Door Handle Operation



5 Chimney Systems

A. Chimney Systems

A chimney or flue system is required to run your wood appliance safely and efficiently. When a fire is started in the fire box hot gases are released and exit the firebox into the chimney system. These hot gases heat up the chimney system and create a vacuum in the firebox or commonly referred to as drafting. As a result, more air is pulled into the firebox through the air openings. When more air is pulled into the fire, the fire burns hotter and is a cleaner burn. This also means that the burn time is shorter but more heat is generated to heat the living space and the glass stays cleaner. When the air controls are adjusted and reduced, the fire will slow down. This lowers the draft and as a result, the burn times are longer.

When lighting the appliance, it is important to get a hot fire as quick as possible to establish the draft in the system for an efficient and clean burn. There are many different types of chimney systems, check with your local authority for more details and follow all regulations in your area.

B. Drafting

Weather and chimney location can affect the draft of your appliance resulting in different performance settings. For windy conditions, the draft may be higher which will result in changing the air control settings for the same performance. In areas where high wind is common, a damper may need to be installed in the flue pipe to best control the appliance. Performance can also be influenced by changes in humidity including fog. Adjust the air controls as needed to achieve the desired heat output of your Curve wood burning appliance.

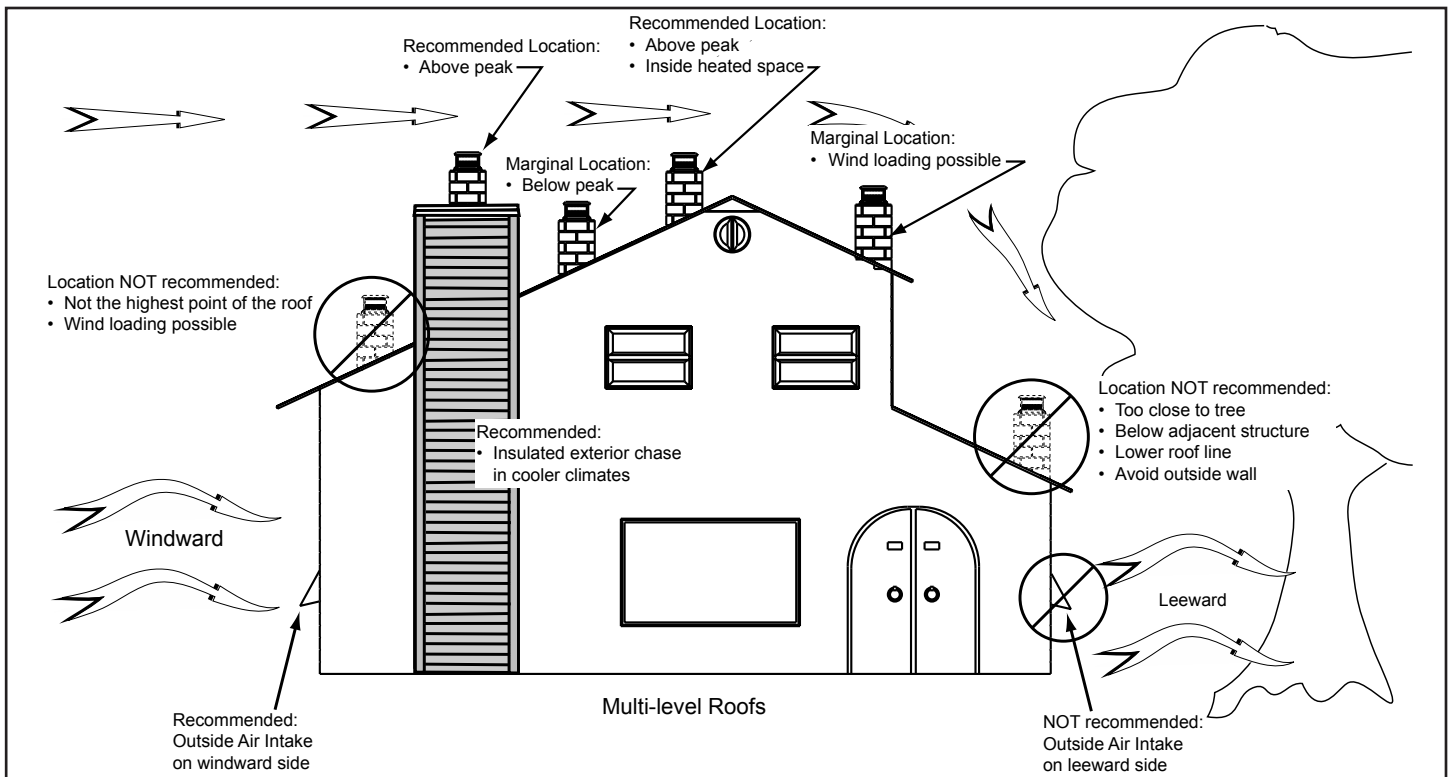

Fig. 13.1

6 Maintenance

A. Ash Drawer

(Figure 14.1)

Before attempting any maintenance on the appliance ensure that the appliance is cold and has no embers in the firebox. To access the ash drawer open the glass front. The drawer is located under the firebox. Before removing pan empty ash from firebox into the pan.

To do this open the grate at the bottom of the firepot using a fire stoking tool and sliding the top grate counter-clockwise until all holes are open. Then gently sweep ash through the grate into the ash drawer below. Then, using stoking tool again, close the grate so that only the two small holes in the back of the appliance are open.

Then remove the ash pan drawer and empty into non-combustible container. **Never** attempt to open ash pan when appliance is lit.

Figure 14.1 Ash Drawer Maintenance

Turn grate counter-clockwise to open all grates.



After all holes open push ash through grates to drawer below.



Remove drawer by pulling out and empty into qualified container.



B. Refractory

The firebox is lined with molded refractory firebrick. The refractory protects the outside of the appliance and retains the heat necessary for a clean efficient burn. The material is a porous ceramic material that can break from abuse. Occasionally, surface cracks may propagate from normal use through the heating and cooling cycle. Surface cracks are normal and should only be a concern when the crack causes the refractory to not remain in place on its own.

C. Baffle Material

There are two baffle plates in the top of the appliance. The purpose of these plates is to restrict and direct the combustion gases to allow for complete combustion of the gasses prior to exiting the firebox and entering the flue. The lower baffle plate is supported on the sides by two steel pins and in the rear by resting on the back refractory panel.

The upper baffle panel is supported by two brackets, one on each side of the top of the firebox. During annual chimney maintenance, these two baffle panels must be removed prior to sweeping. Not doing so will result in broken panels. Similar to the refractory panels lining the inside of the firebox, the baffle panels are subject to wear and tear and are subject to warranty limitations.

D. Proper Burn

- Remove ash from firebox and ash pan regularly to ensure proper air supply
- Use only 1-3 pieces of wood quartered and placed to optimize air flow
- Adjust the upper air control to ensure that enough air is being supplied to the firebox, there should always be a visible flame with minimal smoke
- Fuel should never be stacked above the upper air inlets

E. Coated Surfaces

To clean the appliance dust with a lint-free cloth or cleaning device. If the topcoat is damaged it is possible to purchase a repair spray from your local dealer. It is possible that this spray may be slightly different from the original coat. For best results, use repair spray in wide area in order to create a subtle transition from one color to the next. For safety purposes apply spray when appliance is cold, the difference in color may be very noticeable when first applied. However, after firing again it should match very close to original color.

F. Cleaning the Glass

This appliance is designed to minimized soot build-up. To attain this the appliance must be burned properly, see section **For Proper Burn**. However even when burned properly a slight buildup of soot can occur. To clean you can use dry cloth and regular glass cleaner or specialized appliance glass cleaning products.

7 Troubleshooting

Smoke escaping

- Damp wood
- Chimney not drawing properly
- Chimney is not properly dimensioned for the appliance
- Check if the smoke gas pipe/chimney are blocked
- Is the chimney the right height for its surroundings?
- At rear outlet, check that the flue pipe does not obstruct the chimney draught
- Vacuum in room
- The door is opened before the embers have burned down sufficiently

Wood burning too quickly

- The air valves are set incorrectly
- The baffle plates are incorrectly mounted or missing
- Inferior firewood (waste wood, pallets etc.)
- Chimney too large

Soot build-up on glass

- Incorrect secondary airflow setting
- Excessive primary air
- Damp wood
- Wood pieces too large on lighting

- Inferior firewood (waste wood, pallets etc.)
- Chimney not drawing sufficiently
- Vacuum in room

Excessive soot build-up in chimney

- Poor burning (more air required)
- Damp wood

The surface of the appliance is turning grey

- Overheating (see instructions for heating)

Poor heating performance of appliance

- Damp wood
- Not enough wood
- Inferior wood quality with low fuel value
- Baffle plates are not fitted correctly
- Odor coming from appliance
- The lacquer on the appliance hardens when you use the appliance for the first time; this can cause an odor. Open a window or a door for ventilation, and make sure the appliance is heated up sufficiently to avoid odors later.
- When heating up and cooling down, the appliance may make some clicking noises. These are due to the huge temperature differences to which the material is exposed and do not indicate any product defects.

Start Fire Problems	Possible Cause	Solution
Can't get fire started Excessive smoke or spillage Burns too slowly Smolders, sizzles	Not enough kindling/paper or no kindling/paper	Use dry kindling, more paper. Arrange kindling & wood for air movement.
	Not enough air for fire to ignite	Check for restricted cap/shroud
		Open outside air kit (if installed).
		Check for flue blockage.
	Check for adequate vent height (refer to chimney assembly section).	
	Wood condition is too wet, too large	Use dry, seasoned wood (refer to wood fuel section).
	Bed of coals not established before adding wood	Start with paper & kindling to establish bed of coals (refer to starting fire section).
Flue blockage such as birds' nests or leaves in termination cap	Have chimney inspected for creosote and cleaned by a certified chimney sweep.	
Down draft or negative pressure Competition with exhaust devices	Do not use exhaust fans during start-up (refer to negative pressure section).	
	Open window below the appliance towards the wind.	
Fire burns too fast	Extremely dry or soft wood	Mix in hardwood.
		Mix in less seasoned wood after fire is established (refer to wood fuel section).
	Over drafting	Check for correct vent height; too much vertical height creates over drafting.
		Check location of vent termination (refer to chimney requirements section).
	ARS door may not be closed completely	Handle set screw rotated on ash door rod - Follow installation instructions
Ash left on ARS door	No seal is created. Clean off top of ARS door for complete seal.	

8 Warranty

Hearth & Home Technologies Inc. (“HHT”) extends the following warranty for Heat & Glo Curve Series wood appliances

WARRANTY COVERAGE AND PERIOD:

HHT warrants that your Heat & Glo Curve Series wood appliance will be free from defects in materials and workmanship at the time of manufacture. This warranty is subject to Conditions, Exclusions and Limitations described below.

Warranty coverage begins on the date of installation. The warranty for parts and labor as follows:

- Five (5) years material, three (3) years labor on the firebox; and
- Two (2) years on all other parts except “consumable parts” which are addressed in the exclusion section below.
- 90 days for all replacement parts provided under this warranty

Documentation of material or production defect must be submitted in order to be eligible for warranty coverage. All claims must be submitted with a date of purchase invoice or a valid warranty card. The warranty periods commence at the earlier of the date of purchase or 24 months following the date of manufacture, regardless of the purchase or installation date. The date of manufacture can be found on the serial label.

Only the original purchaser of the appliance may make a claim under this warranty and it applies only with respect to appliance in the original site of its installation. This warranty applies only for appliances purchased from an authorized HHT distributor / dealer.

WARRANTY EXCLUSIONS:

This warranty does not cover the following:

- Damage to painted surfaces caused by fingerprints, accidents, misuse, scratches, melted items, or other external sources and residues left on the plated surfaces from the use of abrasive cleaners or polishes.
- Consumable parts including paint, gaskets, glass, ash pan assembly, refractory, grates (except to the extent such parts are found to be defective or damaged at the time of installation).
- Damages resulting from
- Failure to install, operate, or maintain the appliance in accordance with the installation instructions, operating instructions, and listing agent identification label furnished with the appliance
- Over firing the appliance which can generally be identified by bubbling, cracking and discoloration of the steel
- The appliance being subjected to prolonged periods of dampness or condensation.
- Water or weather damage including, damage as a the result of improper chimney or venting installation
- Failure to install the appliance in accordance with local building codes
- Improper operation, abuse, misuse, continued operation with damaged, corroded or failed components, accident, or improperly/incorrectly performed repairs
- Environmental conditions, inadequate ventilation, negative pressure, or drafting caused by tightly sealed constructions, insufficient make-up air supply, or handling devices such as exhaust fans or forced air furnaces or other such causes
- Use of fuels other than those specified in the operating instructions
- Installation or use of components not supplied with the appliance or any other components not expressly authorized and approved by HHT;

HHT’s obligation under this warranty does not extend to the appliances’ capability to heat the desired space. Information is provided to assist the consumer and the dealer in selecting the proper appliance for the application. Consideration must be given to appliance location and configuration, environmental conditions, insulation and air tightness of the structure.

9 Service Parts List

HEAT & GLO™

No one builds a better fire

Service Parts

Wood Stove

CURVE-100S-HS

Beginning Manufacturing Date: June 2013

Ending Manufacturing Date: Active

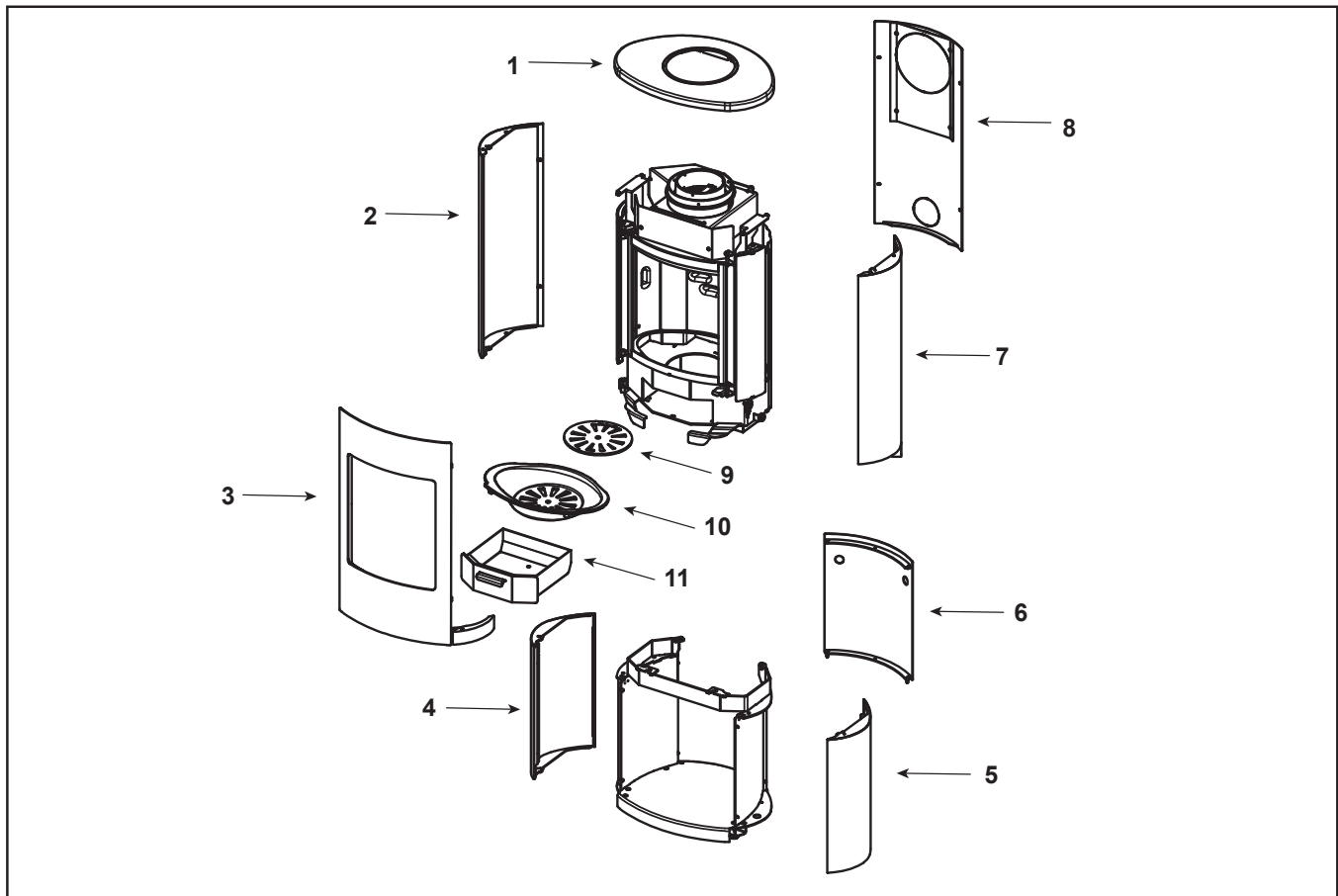

IMPORTANT: THIS IS DATED INFORMATION. Parts must be ordered from a dealer or distributor. **Hearth and Home Technologies does not sell directly to consumers.** Provide model number and serial number when requesting service parts from your dealer or distributor.

ITEM	DESCRIPTION	COMMENTS	PART NUMBER
1	Top		MG10-091
2	Side Panel, Left		MG06-021
3	Door Assembly		MG10-131
4	Side Panel Pedestal, Left		MG10-051
5	Side Panel Pedestal, Right		MG10-061
6	Rear Pedestal Plate		MG10-211
7	Side Panel, Right		MG10-031
8	Back Panel		MG06-111
9	Firepot Plate		MG06-331
10	Cast Firepot		7G06-201
11	Ashpan		MG06-121
	Baffle Pin		SRV7G06-2M1
	Black Handle Cover		7G10-912B
	Brick Set		MG10-381
	Glass		IG06-071

HEAT & GLO

No one builds a better fire

Service Parts

Wood Stove

CURVE-300G-HS

Beginning Manufacturing Date: June 2013

Ending Manufacturing Date: Active

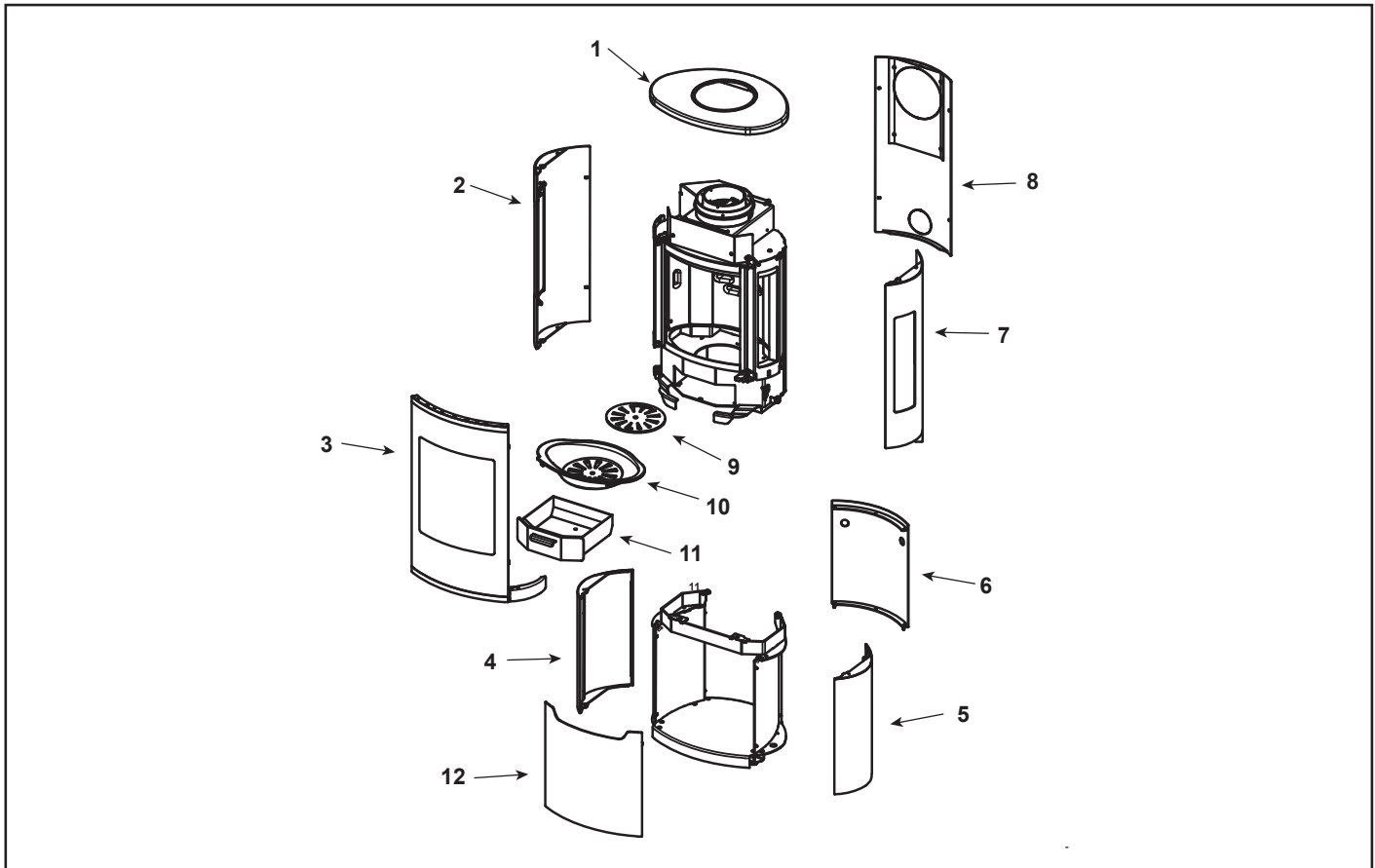

IMPORTANT: THIS IS DATED INFORMATION. Parts must be ordered from a dealer or distributor. **Hearth and Home Technologies does not sell directly to consumers.** Provide model number and serial number when requesting service parts from your dealer or distributor.

ITEM	DESCRIPTION	COMMENTS	PART NUMBER
1	Top		MG10-091
2	Side Panel, Left		7G08-551
3	Door Assembly		MG10-161
4	Side Panel Pedestal, Left		MG10-051
5	Side Panel Pedestal, Right		MG10-061
6	Rear Pedestal Plate		MG10-211
7	Side Panel, Right		MG10-191
8	Back Panel		MG06-111
9	Firepot Plate		MG06-331
10	Cast Firepot		7G06-201
11	Ashpan		MG06-121
12	Front Door Pedestal Cover		MG10-201
	Baffle Pin		SRV7G06-2M1
	Black Handle Cover		7G10-912B
	Glass		IG06-051
	Side Glass		IG06-031

11/17

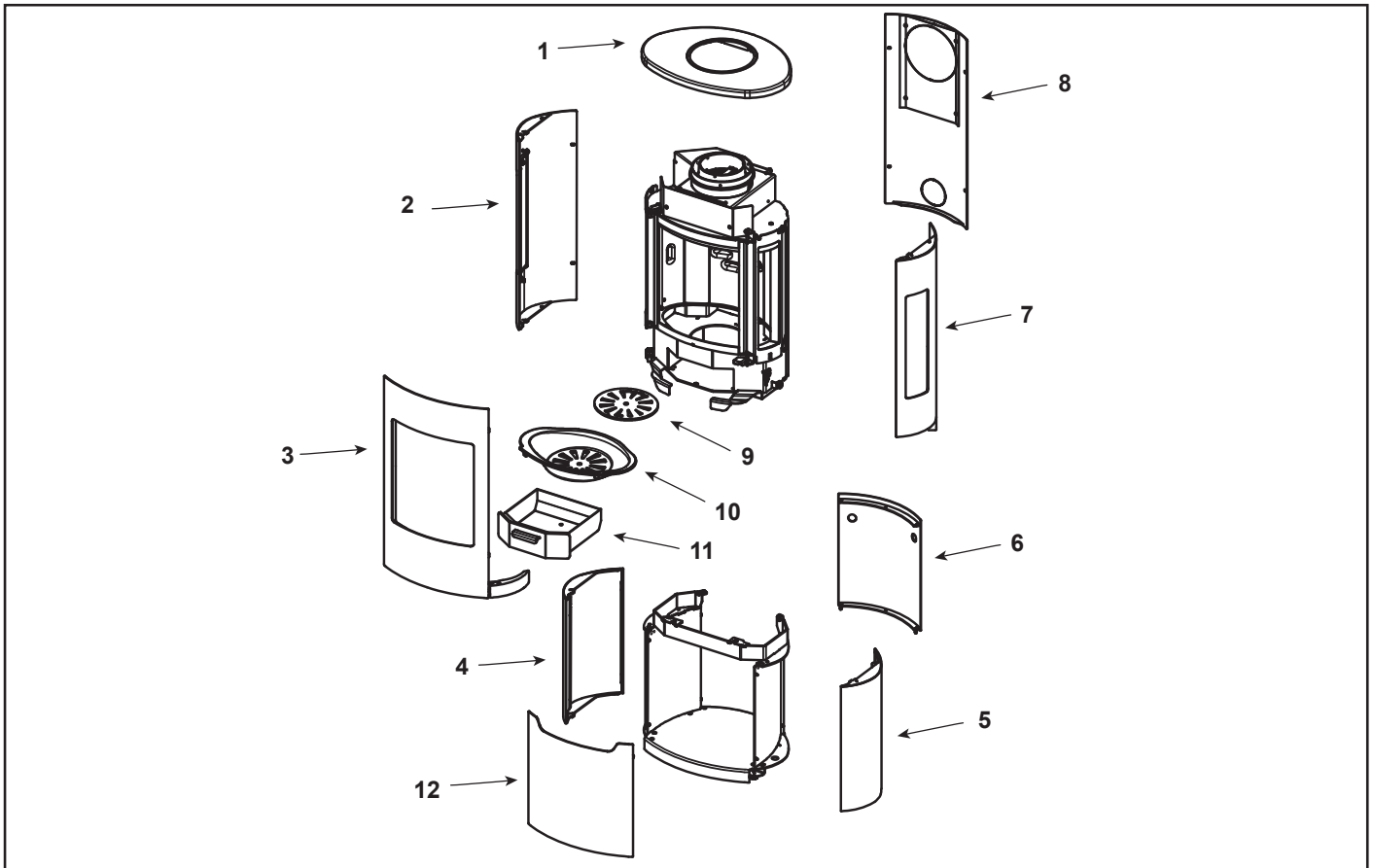

IMPORTANT: THIS IS DATED INFORMATION. Parts must be ordered from a dealer or distributor. **Hearth and Home Technologies does not sell directly to consumers.** Provide model number and serial number when requesting service parts from your dealer or distributor.

ITEM	DESCRIPTION	COMMENTS	PART NUMBER
1	Top		MG10-091
2	Side Panel, Left		MG06-181
3	Door Assembly		MG10-131
4	Side Panel Pedestal, Left		MG10-051
5	Side Panel Pedestal, Right		MG10-061
6	Rear Pedestal Plate		MG10-211
7	Side Panel, Right		MG10-191
8	Back Panel		MG06-111
9	Firepot Plate		MG06-331
10	Cast Firepot		7G06-201
11	Ashpan		MG06-121
12	Front Door Pedestal Cover		MG10-201
	Baffle Pin		SRV7G06-2M1
	Black Handle Cover		7G10-912B
	Glass		IG06-071
	Side Glass		IG06-031



No one builds a better fire

CONTACT INFORMATION:

Hearth & Home Technologies
20802 Kensington Blvd.
Lakeville, MN, 55044, USA
www.hearthnhome.com
Division of HNI INDUSTRIES

**We recommend that you record the following pertinent information
for your heating appliance**

Date purchased/installed: _____

Serial Number: _____ Location on appliance: _____

Dealership purchased from: _____ Dealer phone: _____

Notes: _____

This product may be covered by one or more of the following patents: (United States) 5341794, 5263471, 6688302, 7216645, 7047962 or other U.S. and foreign patents pending.

