

Owner's Manual

Installation & Operation

INSTALLER: Leave this manual with party responsible for use and operation.

OWNER: Retain this manual for future reference.

NOTICE: SAVE THESE INSTRUCTIONS



PP130 Pellet Stove

Model(s):

PP130



Tested and
Listed by
UL
C US
Portland
Oregon USA
OMNI-Test Laboratories, Inc.
Report #: 061-S-88-2



WARNING



If the information in these instructions is not followed exactly, a fire may result causing property damage, personal injury, or death.

- Do not store or use gasoline or other flammable vapors and liquids in the vicinity of this or any other appliance.
- Do not overfire - If heater or chimney connector glows, you are overfiring. Overfiring will void your warranty.
- Comply with all minimum clearances to combustibles as specified. Failure to comply may cause house fire.

WARNING



HOT SURFACES!

Glass and other surfaces are hot during operation AND cool down.

Hot glass will cause burns.

- Do not touch glass until it is cooled
- NEVER allow children to touch glass
- Keep children away
- CAREFULLY SUPERVISE children in same room as fireplace.
- Alert children and adults to hazards of high temperatures
- **High temperatures may ignite clothing or other flammable materials.**
- Keep clothing, furniture, draperies and other flammable materials away.

NOTE

To obtain a French translation of this manual, please contact your dealer or visit www.pelprostoves.com

Pour obtenir une traduction française de ce manuel, s'il vous plaît contacter votre revendeur ou visitez www.pelprostoves.com

SAFETY NOTICE: PLEASE READ THIS ENTIRE MANUAL BEFORE INSTALLATION AND USE OF THIS PELLET FUEL-BURNING ROOM HEATER. FAILURE TO FOLLOW THESE INSTRUCTIONS COULD RESULT IN PROPERTY DAMAGE, BODILY INJURY OR EVEN DEATH. CONTACT LOCAL BUILDING OFFICIALS ABOUT RESTRICTIONS AND INSTALLATION INSPECTION REQUIREMENTS IN YOUR AREA.

Questions, problems, missing parts?

Before returning to your retailer, visit
www.pelprostoves.com or call customer
service at 877-427-3316.

This heater meets the U.S. Environmental Protection Agency's emission limits for wood heaters sold after July 1, 1990.



QUICK START GUIDE

Before you plug in this appliance, follow these instructions

All material needs to be removed from the door glass and firebox before operation

1. Turn Dial Control to OFF.



2. Add pellets to hopper and close lid.

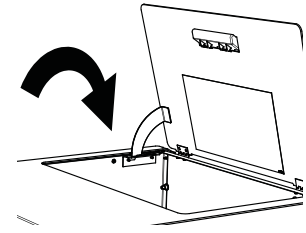

3. Verify firepot's orientation is correct.

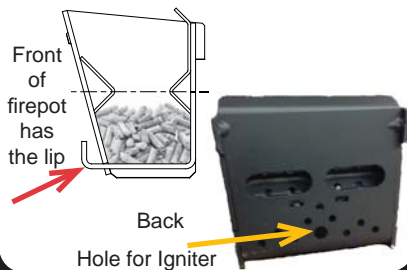

4. Check all three baffles are hooked into slots.



5. Plug power cord into wall receptacle.

Green light will start flashing one time per second

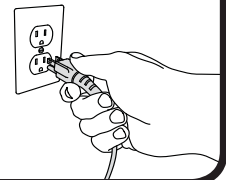

6. To prime the feed tube, QUICKLY turn the dial control from OFF to HI, back to OFF, then back to HI.

The light should stop blinking and light up solid green



NOTE: Priming is only required the first time the appliance is lit, or after the hopper has run completely out of pellets.

If ignition is missed, empty the firepot and repeat step 3.

NOTE: If the light does not change to solid green, turn the control back to off, unplug the appliance and repeat steps 5 & 6.

7. Stove will feed for two minutes. *Green light will start blinking continuously, to indicate startup sequence*

NOTE: Allow the unit five minutes for ignition to take place.

8. Once a fire has been established in the unit, leave the unit burning on HI for 30 minutes to allow the paint to cure.

NOTE: Odors and vapors released during initial operation.

- Curing of high temperature paint.
- Open windows for air circulation.

*Odors may be irritating to sensitive individuals.

9. After 30 minutes have passed, turn dial control to OFF, and allow unit to cool completely. Once unit has cooled, open door and clean firepot according to the cleaning instructions found on the inside of the hopper lid, or in the owners manual.

Unit is now ready to resume normal operation

Safety Alert Key:

- **DANGER!** Indicates a hazardous situation which, if not avoided will result in death or serious injury.
- **WARNING!** Indicates a hazardous situation which, if not avoided could result in death or serious injury.
- **CAUTION!** Indicates a hazardous situation which, if not avoided, could result in minor or moderate injury.
- **NOTICE:** Indicates practices which may cause damage to the appliance or to property.

TABLE OF CONTENTS

<p>1 Listing and Code Approvals5</p> <p>A. Appliance Certification5</p> <p>B. Mobile Home Approved5</p> <p>C. Glass Specifications5</p> <p>D. Electrical Rating (On High)5</p> <p>E. BTU & Efficiency Specifications5</p> <p>2 General Information6</p> <p>A. Fire Safety6</p> <p>B. Non-Combustible Materials6</p> <p>C. Combustible Materials6</p> <p>D. Fuel Material and Fuel Storage6</p> <p>E. Before Your First Fire6</p> <p>3 General Operating Information7</p> <p>A. User Dial Control7</p> <p>B. Filling the Hopper7</p> <p>C. Priming the Feed Tube7</p> <p>D. Firepot Purge8</p> <p>E. Shutdown8</p> <p>F. Starting Your First Fire8</p> <p>G. Fire Characteristics8</p> <p>H. Your Pellet Appliance - General Operating Parts9</p> <p>I. LED Color Coding Chart and Explanation10</p> <p>J. Ignition Cycles11</p> <p>K. Running in Minimum or Maximum11</p> <p>L. Running in the Comfort Level Mode11</p> <p>M. Clear Space11</p> <p>N. Trim Adjustment11</p> <p>4 Maintaining & Servicing the Appliance12</p> <p>A. Proper Shutdown Procedure12</p> <p>B. Quick Reference Maintenance Chart12</p> <p>C. General Maintenance12</p> <p>D. High Ash Fuel Content Maintenance16</p> <p>E. Frequently Asked Questions17</p> <p>5 Replacement Parts18</p> <p>A. Convection Blower Replacement18</p> <p>B. Exhaust Blower Replacement18</p> <p>C. Snap Disc Replacement19</p> <p>D. Igniter Replacement19</p> <p>E. Baffle Removal & Replacement19</p> <p>F. Glass Replacement20</p> <p>G. Feed Motor Replacement20</p> <p>H. Feed Spring Replacement20</p> <p>I. Control Board Replacement20</p> <p>J. Fuse Replacement20</p>	<p>6 Getting Started21</p> <p>A. Design, Installation & Location Considerations21</p> <p>B. Draft21</p> <p>C. Negative Pressure21</p> <p>D. Locating Your Appliance & Chimney22</p> <p>E. Inspect Appliance & Components22</p> <p>F. Tools And Supplies Needed22</p> <p>7 Dimensions and Clearances23</p> <p>A. Appliance Dimensions23</p> <p>B. Clearances to Combustibles (UL and ULC)23</p> <p>C. Hearth Pad Requirements (UL and ULC)24</p> <p>8 Vent Information25</p> <p>A. Chimney and Exhaust Connection25</p> <p>B. Venting Termination Requirements25</p> <p>C. Pellet Venting Charts26</p> <p>9 Venting Systems27</p> <p>A. Vertical - Interior - Typical Installation27</p> <p>B. Through The Wall & Vertical - External - Horizontal27</p> <p>C. Vertical into Existing Class A Chimney27</p> <p>D. Masonry28</p> <p>E. Alternate Masonry28</p> <p>F. Through The Wall29</p> <p>10 Mobile Home30</p> <p>A. Mobile Home Installation30</p> <p>11 Appliance Set-Up31</p> <p>A. Removal From Pallet31</p> <p>B. Outside Air Kit Instructions31</p> <p>C. Power up the Unit31</p> <p>D. Hopper Extension (Optional Accessory)31</p> <p>12 Troubleshooting32</p> <p>13 Reference Materials35</p> <p>A. Component Function35</p> <p>B. Wiring Diagram35</p> <p>C. Replacement Parts36</p> <p>D. Service & Maintenance Log38</p> <p>E. Warranty39</p>
---	---

CAUTION

After reading these instructions, if you have any doubt about your ability to complete your installation in a professional manner you should obtain the services of an installer versed in all aspects as to the correct and safe installation. Do not use temporary makeshift compromises during installation.

BEFORE INSTALLATION OF YOUR APPLIANCE

1. Check with the building inspector's office for compliance with local codes; a permit may be required.
2. Use 3" or 4" (76-102mm) diameter type "L" or "PL" venting system. It can be vented vertically or horizontally. Approved adaptors can be used to connect the "L" or "PL" to approved wood stove venting such as single wall or double wall venting previously used to vent a wood burning appliance. **INSTALL VENT AT CLEARANCES SPECIFIED BY THE VENT MANUFACTURE.**
3. Always connect this unit to an approved chimney system and **NEVER** vent to another room or inside a building.
4. **DO NOT INSTALL A FLUE DAMPER IN THE EXHAUST VENTING SYSTEM OF THIS UNIT.**
5. **DO NOT CONNECT THIS UNIT TO A CHIMNEY FLUE SERVING ANOTHER APPLIANCE.**
6. **DO NOT CONNECT TO OR USE IN CONJUNCTION WITH ANY AIR DISTRIBUTION UNLESS SPECIFICALLY APPROVED FOR SUCH INSTALLATION.**
7. The connector pipe and chimney should be inspected periodically and cleaned if necessary. Review additional information located in the maintenance section of this Owner's Manual.
8. Remember the clearance distances when you place furniture or other objects within the area. This includes heat sensitive materials such as candles, seasonal decorations or draperies. **DO NOT STORE WOOD, FLAMMABLE LIQUIDS OR OTHER COMBUSTIBLE MATERIALS TOO CLOSE TO THE UNIT.**
9. Be aware of the required clearances when locating the unit. Refer to the label on the rear of the unit for required clearances.
10. Contact your local municipal or provincial fire authority for information of how to handle a chimney fire. Have a clear understood plan to handle a chimney fire. In the event of a chimney fire, **CALL THE FIRE DEPARTMENT.**
11. Prior to burning the unit for the first time make sure the hardware kit has been removed from the firebox.

IMPORTANT

It is highly recommended that the pellet heater and chimney be installed by a qualified installer. A qualified installer is a person or entity who regularly installs solid burning fuel products and chimneys in the course of their ordinary business.



WARNING



Fire Risk

Tested and approved for wood pellets.
Burning of any over type of fuel will void your warranty.

1 Listing and Code Approvals

A. Appliance Certification

Series:	PP130
Laboratory:	OMNI Test Laboratories
Report No.	061-S-88-2
Type:	Solid Fuel Room Heater/Pellet Fuel Burning Type
Tested and Certified to:	ASTM E1509-12 and ULC S627-00, Room Heater Pellet Fuel Burning type and (UM) 84-HUD, Mobile Home Approved.

NOTE: This installation must conform with local codes. In the absence of local codes you must comply with the **ASTM E1509-12 and ULC S627-00 by OMNI Test Laboratories and (UM) 84-HUD.**

These heaters meet the US Environmental Protection Agency's Emission limits for pellet heaters. Under specific conditions the PP130 stove has shown to deliver heat at rates ranging from 11,000 to 50,000 BTU/hr.

B. Mobile Home Approved

- This appliance is approved for mobile home installations when not installed in a sleeping room and when an outside combustion air inlet is provided.
- The structural integrity of the mobile home floor, ceiling, and walls must be maintained.
- The appliance must be properly grounded to the frame of the mobile home with #8 copper ground wire, and use only listed double-wall connector pipe.
- Outside Air Kit provided with each unit must be installed in a mobile home installation.

C. Glass Specifications

This appliance is equipped with 5mm ceramic glass. Replace glass only with 5mm ceramic glass. Please contact Pelpro for replacement glass.

D. Electrical Rating (On High)

PP130 Series: 120 VAC, 60 Hz, Start 2.6 Amps, Run 2.3 Amps

E. BTU & Efficiency Specifications

*BTU input will vary, depending on the brand of fuel you use in your stove. **Heating capacity depends on climate zone, structure layout, insulation, windows, etc.

MODEL: PP130	
Particulate Emissions Rating:	1.60 grams / hr
*BTU Input:	11,000 - 50,000 / hr
Efficiency:	86.5 %
**Heating Capacity:	1,225 to 2,200 sq. ft. depending on climate zone
Hopper Capacity: (Approx)	130 lbs
Fuel:	Wood Pellets
Shipping Weight:	239 lbs

WARNING



Fire Risk

Pelpro disclaims any responsibility for, and the warranty and agency listing will be voided by the below actions.

DO NOT:

- Install or operate damaged appliance
- Modify appliance
- Install other than as instructed by the manufacturer.
- Operate the appliance without fully assembling all components
- Over fire
- Install any component not approved by the manufacturer
- Install parts or components not Listed or approved
- Disable safety switches

Improper installation, adjustment, alteration, service or maintenance can cause injury or property damage.

For assistance or additional information, consult a qualified installer, service agency or your dealer.

2 General Information

A. Fire Safety

To provide reasonable fire safety, the following should be given serious consideration:

- Install at least one smoke detector on each floor of your home.
- Install at least one carbon monoxide detector on each floor of your home.
- Locate smoke detector away from the heating appliance and close to the sleeping areas.
- Follow the smoke detector manufacturer's placement and installation instructions and maintain regularly.
- Follow the carbon monoxide manufacturer's placement and installation instructions and maintain regularly.
- Conveniently locate a Class A fire extinguisher to contend with small fires.
- In the event of a hopper, creosote, or chimney fire:
 - Evacuate the house immediately.
 - Notify fire department.

B. Non-Combustible Materials

Material which will not ignite and burn, composed of any combination of the following:

- Steel
- Brick
- Concrete
- Glass
- Plaster
- Iron
- Tile
- Slate

Materials reported as passing **ASTM E 136, Standard Test Method for Behavior of Metals, in a Vertical Tube Furnace of 750° C.**

C. Combustible Materials

Material made of/or surfaced with any of the following materials:

- Wood
- Plant Fibers
- Plywood/OSB
- Compressed Paper
- Plastic
- Sheet Rock (drywall)

Any material that can ignite and burn: flame proofed or not, plastered or un-plastered.

D. Fuel Material and Fuel Storage

Pellet fuel quality can greatly fluctuate. We recommend that you buy fuel in multi-ton lots whenever possible. However, we do recommend trying various brands before purchasing multi-ton lots to ensure your satisfaction.

Fuel Material

- Made from sawdust or wood by-products
- Depending on the source material it may have a high or low ash content.

Higher Ash Content Material

- Hardwoods with a high mineral content
- Fuel that contains bark
- Standard grade pellets or high ash pellets

Fuel Material and Fuel Storage (Cont'd)

Lower Ash Content Material

- Most softwoods
- Fuels with low mineral content
- Most premium grade pellets

Clinkers

Minerals and other non-combustible materials such as sand will turn into a hard, glass-like substance called a clinker when heated in the firepot.

Trees from different areas will vary in mineral content. That is why some fuels produce more clinkers than others.

Moisture

Always burn dry fuel. Burning fuel with high moisture content takes heat from the fuel and tends to cool the appliance, robbing heat from your home. Damp pellet fuel can clog the feed system.

Size

- Pellets are either 1/4 inch or 5/16 inch (6-8mm) in diameter
- Length should be no more than 1-1/2 inches (38mm)
- Pellet lengths can vary from lot to lot from the same manufacturer
- Due to length variations, the feed rate may need adjusting occasionally

Performance

- Higher ash content requires the firepot and the ash drawer to be emptied more frequently
- Hardwoods require more air to burn properly
- Premium wood pellets produce the highest heat output
- Burning pellets longer than 1-1/2 inches (38mm) can cause an inconsistent fuel feed rate and/or missed ignitions of feed jams.

Storage

- Wood pellets should be left in their original sealed bag until using to prevent moisture absorption
- Do not store any pellet fuel within the clearance requirements or in an area that would hinder routine cleaning and maintenance

E. Before Your First Fire

1. First, make sure your appliance has been properly installed and that all safety requirements have been met. Pay particular attention to the fire protection and venting.
2. Double check that the firebox is empty and the firepot is in place!
3. Close and latch the door.

3 General Operating Information

A. User Dial Control

The appliance has one dial control located on the side of the unit used for daily operation. There are four primary settings on this dial.

1) OFF: When the dial indicator is in the off position the unit will go into a shut down and remain off until the dial is turned to one of the other three settings. The LED will flash green once per second when in the off position.

2) LO : When the dial indicator is directed to the LO setting the unit will burn on low until the hopper runs out of pellets or the dial control is turned to a different setting. When in this setting the LED will be amber in color and continuously on. When burning in this mode, the unit should be turned off at least once daily for cleaning. If lower quality fuels are used, additional daily shut downs may be required for cleaning.

3) HI : Similar to the LO mode, the unit will run continuously at the high burn rate until the unit has run out of fuel or the dial is turned to a different setting. To operate in this mode, turn the dial clockwise until it stops. When in this setting the LED will be amber in color and continuously on. Follow the daily cleaning recommendations when operating in this mode. If lower quality fuels are used, additional daily shut downs may be required for cleaning.

4) COMFORT LEVEL : To burn in the Comfort Level mode, turn the dial control clockwise to the desired comfort level. When operating in the automatic mode, the unit changes the burn setting based on the difference between the room temperature and the desired set point. When burning in this mode the LED will be blinking green. The number of green flashes corresponds to the current setting. In other words, the unit will burn on High if the difference between the desired and room temperature is greater than 8 degrees Fahrenheit. As the room heats up and the gap closes, the unit will automatically reduce the burn rate. When the room temperature is close to the set point the light will stop flashing and stay solid green. at this time the stove will be burning on the lowest burn rate. When the desired temperature is achieved the unit will shut down. As the room cools, the unit will restart automatically.

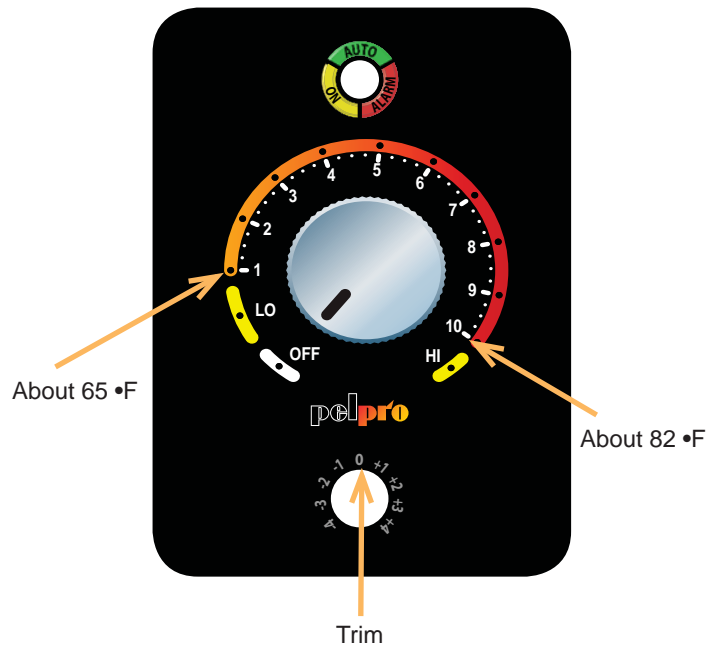

B. Filling the Hopper

Open the hopper lid by lifting the handle. The hopper lid will open past ninety degrees and stay open automatically. Fill the hopper with fuel. **FOR USE WITH ONLY WOOD PELLET FUEL.** Close the hopper lid.

NOTE: The unit will not feed with the hopper lid open. If left open, the fire will go out.

C. Priming the Feed Tube

Only if the hopper is being filled for the first time or the unit had previously run out of pellets, the feed tube may need to be primed. To do this, turn the dial control from the OFF position to the HI position two times. This will run the feed motor continuously for two minutes without turning the igniter on. When the auger is running continuously, the LED will be a continuous green color. The system will run the auger for 2 minutes. When pellets start to drop into the firepot, the feed tube is primed; turn the dial control to the desired position and the stove will begin its ignition sequence (The green LED will flash rapidly).

Priming the Feed Tube (Cont'd)

A FIREPOT THAT IS MORE THAN HALF FULL IS OVER-FILLED. DO NOT OVERFILL FIREPOT FOR IGNITION. If there are excessive pellets in the firepot the starts will be extremely smoky and cause an unstable ignition that includes but not limited to rumbling and whistling.



D. Firepot Purge

A feature of these pellet stoves is the firepot purge cycle. The frequency of the cycle is once every half hour the unit is burning. During this event, the feed is reduced to the lowest setting and the exhaust blower ramps up to the highest setting. The purpose of the purge cycle is to help remove debris from the firepot and help the unit burn as efficient as possible. The cycle lasts 99 seconds. Please be aware that the purge does not replace daily cleaning activities but makes them easier.

E. Shutdown

To shut the appliance down, turn the dial control counter clockwise to the OFF position. During the shutdown process, the LED will flash green rapidly just like the ignition sequence. The firepot burn down cycle will begin but without the feed motor running. The feed will be terminated during this shutdown process. The exhaust and convection blowers will remain on during the shutdown process until the exhaust has cooled.

If maintenance or daily cleaning is going to be conducted immediately following a shutdown, please use caution as components especially those inside the firebox may still be hot.

Please note that if the dial control is turned to the off position and back on, even if by mistake, the unit will go through the shutdown sequence.

F. Starting Your First Fire

- 1) Turn the dial control to "OFF".
- 2) Make sure the firepot is clean, in place, and free of debris.
- 3) Plug the unit into the wall and fill the hopper with wood pellets. Shut the hopper lid.
- 4) Turn the dial control to the desired burn setting.

The unit will go into the ignition sequence (The green LED will flash rapidly). The ignition sequence involves the exhaust blower turning on, the igniter turning on, and the feed motor running in two stages. The first stage involves the feed motor running continuously for about a minute to preload pellets into the firepot. Following the preload and a delay, the feed motor will begin cycling on and off. When the pellets are warming up and on the verge of igniting, it is not uncommon for the firebox to fill with smoke. Once ignition actually happens, the smoke should evacuate quickly. During this stage as well as any part during the burn process, the front door should not be opened. This cycle continues until the unit senses ignition by a rise in the exhaust temperature or the unit times out. Following the ignition cycle the unit begins to feed additional pellets gradually for a few minutes to build up the fire.

G. Fire Characteristics

The overall height of the flame will vary throughout the burn for a couple of reasons. First is that the flame will vary based on type of fuel or even batch of fuel. Secondly, the unit adjusts the burn rate according to the how far away the room temperature is from the set temperature. This should not cause alarm. The third characteristic that affects the fire relates to general maintenance and cleaning. Infrequent or poor general maintenance will result in poorer performance. Indicators of the need for additional maintenance activities include a lazy flame, black sooted glass, pellets not igniting, or pellets falling to the side of the firepot. See the maintenance section for additional information.

CAUTION

- Odors and vapors released during initial operation.
- Curing of high temperature paint.
 - Open windows for air circulation.
- Odors may be irritating to sensitive individuals.

WARNING



HOT SURFACES!

Glass and other surfaces are hot during operation AND cool down.

Hot glass will cause burns.

- **DO NOT** touch glass until it is cooled
- NEVER allow children to touch glass
- Keep children away
- CAREFULLY SUPERVISE children in same room as appliance.
- Alert children and adults to hazards of high temperatures.

High temperatures may ignite clothing or other flammable materials.

- Keep clothing, furniture, draperies and other flammable materials away.

NOTICE: If you expect that children may come into contact with this appliance, we recommend a barrier such as a decorative screen. See your retailer for suggestions.

H. Your Pellet Appliance - General Operating Parts

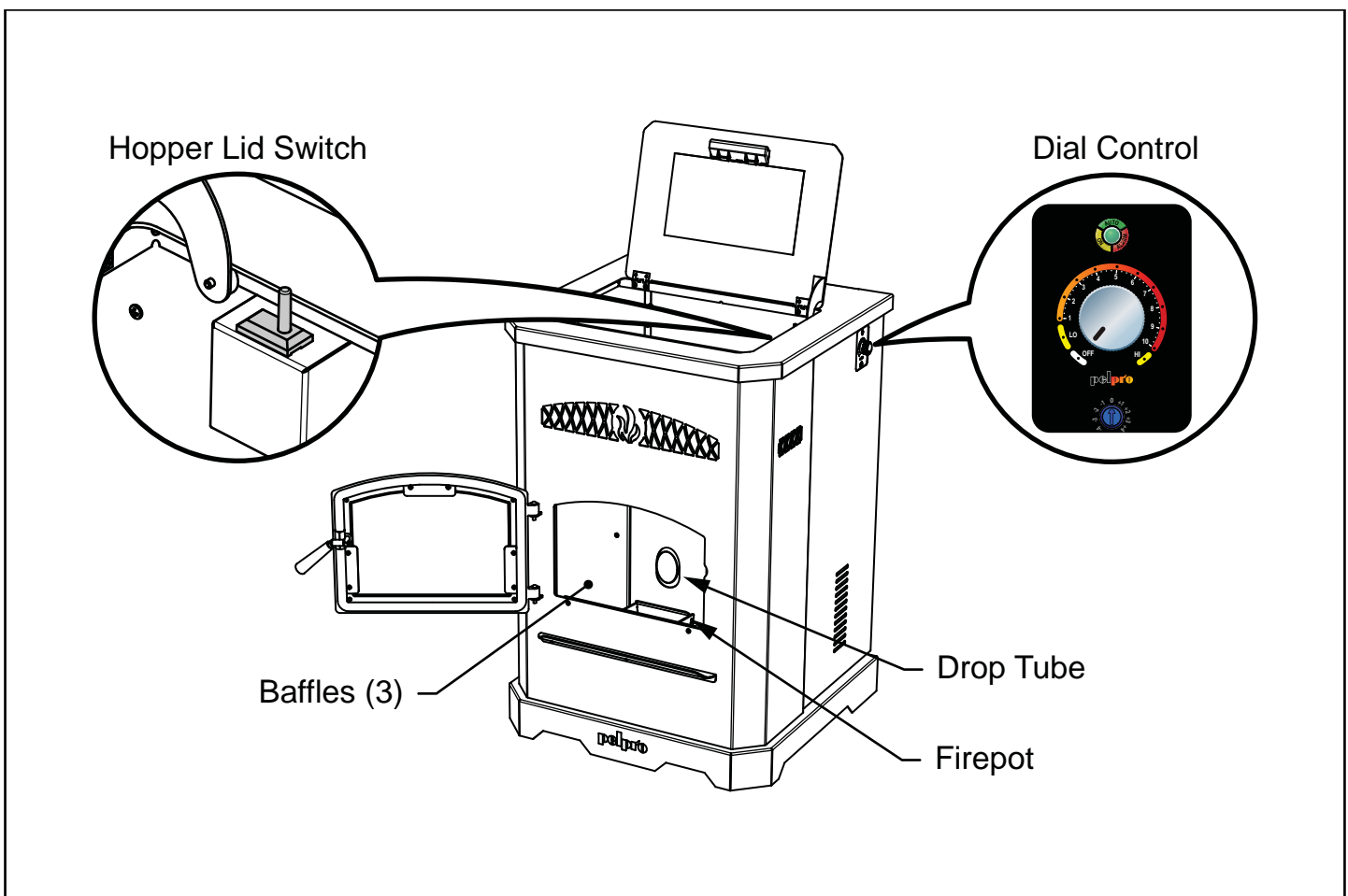

I. LED Color Coding Chart and Explanation

LED Color	Number of Flashes between pauses	Description	Notes
Green	Steady ON while priming feed tube (max time 2 minutes)	Feed Motor is running continuously. (This primes the feed tube).	When priming the feed system and filling the firepot, DO NOT OVERFILL FIREPOT FOR IGNITION. The unit will automatically go into start up following the prime function.
Green	Steady ON while burning	Room temperature is close to set point and burning on lowest burn rate.	
Green	1x while not burning	Unit is off and ready.	To start appliance, follow start up sequence.
Green	Blinks Continuously	Appliance is in the start up/ignition sequence or in shutdown.	During shut down, the blowers will shut off when the exhaust temperature has cooled.
Green	Varies	When in the automatic mode, the number of flashes between pauses indicates the burn rate (1 for low up to 5 for high).	Adjust the dial control to change the desired room temperature.
Amber	Steady ON	Appliance is set and running at either the minimum or maximum power levels.	The unit will shut off only when the hopper runs out of fuel, the user changes the dial control to a different state, or the unit senses an error.
Red	1x	Empty Hopper Alarm	This alarm is caused by the fire going out from lack of fuel. See troubleshooting section for more information.
Red	2x	Exhaust Probe Alarm	Failed component error. See troubleshooting section for more information.
Red	3x	Ambient Probe Alarm	Failed component error. See troubleshooting section for more information.
Red	4x	Missed Ignition	There are a total of 2 tries per ignition sequence. If after 2 tries there is no rise in exhaust temperature this error will occur. See the troubleshooting section for additional information and correction.
Red	8x	Exhaust Gas Over Temperature Alarm	The exhaust temperature exceed the allowable limit. See the troubleshooting section for more information and correction.



WARNING



Fire Risk

Do NOT operate appliance:

- With appliance door open.
- Firepot floor open.

Do NOT store fuel:

- Closer than required clearances to combustibles to appliance
- Within space required for loading or ash removal.

J. Ignition Cycles

1. At the beginning of each ignition cycle, it is normal to see some smoke in the firebox. The smoke will stop once the fire starts.
2. The convection blower will automatically turn on after your appliance has been burning for approximately 10 minutes.

This blower transfers heat from your appliance into the room, and will continue to run even after the unit has shutdown. It will turn off after the exhaust temperature has cooled.

3. Occasionally the appliance may run out of fuel and shut itself down. When this happens the empty hopper alarm will be triggered.

K. Running in Minimum or Maximum

When the dial control is set to run on the LO or HI setting, the appliance will continue to run without regard to the actual temperature in the room. The appliance will shut off only if the dial control is set to a different setting or there is an error such as an empty hopper.

When running on LO or HI it is important to follow the daily cleaning activities especially cleaning the firepot. Failure to do so will reduce the performance of the appliance.

L. Running in the Comfort Level Mode

When the dial control is set to run in the automatic mode the unit will adjust the actual burn rate based on the difference between the room temperature as sensed by the probe located in the rear of the unit and the desired comfort level as set on the dial control.

The comfort level range is from approximately 65 degrees Fahrenheit to 82 degrees Fahrenheit.



Once the desired comfort level is achieved the appliance will automatically shut down and turn off. When the temperature in the room drops 3 degrees below the desired comfort level, the appliance will automatically restart.





M. Clear Space

Mantel: Avoid placing candles and other heat-sensitive objects on mantel or hearth. Heat may damage these objects.

NOTICE: Clearances may only be reduced by means approved by the regulatory authority having jurisdiction.

 WARNING	
	Fire Risk HOT WHILE IN OPERATION. KEEP CHILDREN, CLOTHING, AND FURNITURE AWAY. CONTACT MAY CAUSE SKIN BURNS.

 WARNING	
	Fire Risk Keep combustible materials, gasoline and other flammable vapors and liquids clear of appliance. <ul style="list-style-type: none">• Do NOT store flammable materials in the appliance's vicinity.• Do NOT use gasoline, lantern fuel, kerosene, charcoal lighter fluid or similar liquids to start or "freshen up" a fire in this heater. Keep all such liquids well away from the heater while it is in use as combustible materials may ignite.

N. Trim Adjustment

The trim adjustment is the small dial located below the main dial control.

If the fire is too large, lazy or producing black soot, rotate the dial counterclockwise one level at a time and allow 15 minutes for stabilization before making another adjustment.

If your fire is too small and sometimes goes out when there are pellets in the hopper, rotate the dial clockwise one level at a time and allow 15 minutes for stabilization before making another adjustment.



4 Maintaining & Servicing the Appliance

A. Proper Shutdown Procedure

 **CAUTION**

 **Shock and Smoke Hazard**

- Turn dial control to OFF, let appliance completely cool and exhaust blower must be off. Now you can unplug appliance before servicing.
- Smoke spillage into room can occur if appliance is not cool before unplugging.
- Risk of shock if appliance not unplugged before servicing appliance.

Follow the detailed instructions found in this section for each step listed as referenced in the chart below.

B. Quick Reference Maintenance Chart

Cleaning or Inspection	Frequency		Daily	Weekly	Monthly	Yearly
Firepot	Every 3 bags of fuel	OR	X			
Ash Removal from Firebox	Every 5 bags of fuel or more frequently depending on ash build-up	OR		X		
Glass	When clear view of firepot becomes obscure	OR		X		
Hopper	Every 25 bags of fuel	OR			X	
Exhaust Path, Drop Tube and Behind Baffles	Every 25 bags or more frequently depending on ash build-up	OR			X	
Door Handle & Gasket Inspection	Prior to heating season	OR			X	
Blower, Convection	Every 25 bags or more frequently depending on operating environment.	OR			X	
Blower, Exhaust	More frequently depending on the fuel type	OR				X
Firebox - Prepare for Non-Burn Season	At end of heating season	OR				X
Venting System	Every 3 tons or more frequently depending on the fuel type	OR				X

C. General Maintenance

1. Types of Fuel

The type of fuel you are burning will dictate how often you have to clean your firepot.

If the fuel you are burning has a high dirt or ash content, it may be necessary to clean the firepot more than once a day.

Poor quality fuel will cause clinkers to form in the firepot. A clinker is formed when dirt, ash or a non-burnable substance is heated to 2000°F (1093°C) and becomes glass-like. See section D following for more details on fuels with high ash content.

 **WARNING**

 **Fire Risk**

- **DO NOT USE CHEMICALS OR FLUIDS TO START THE FIRE.**
- **DO NOT BURN GARBAGE OR FLAMMABLE FLUIDS SUCH AS GASOLINE, NAPHTHA, OR ENGINE OIL.**

NOTICE: These are recommendations. Clean more frequently if you encounter heavy build-up of ash at the recommended interval or you see soot coming from the vent. Not properly cleaning your appliance on a regular basis will void your warranty.

2. Cleaning Firepot with the Firepot Clean-Out Tool:

- **Frequency:** Weekly or more often as needed
 - **By:** Homeowner
- a. Turn dial to off.
 - b. The appliance must be in complete shutdown and cool, the exhaust blower off, and the dial turned to off. If you are just cleaning the firepot, there is no need to unplug the appliance.
 - c. Open the front door of the appliance and lift out the firepot. Use the firepot cleaning tool to break up deposits inside the firepot and dispose in an approved container. Depending on the quality of fuel used, the front of the firepot may need to be removed for better access for cleaning.
 - d. Use the narrow end of the firepot cleaning tool to clean the holes.
 - e. With the firepot out, clean the area below the firepot.
 - f. Reassemble the firepot and place back inside the firepot riser. Make sure the firepot is in the correct direction with the slanted lip in the rear. Failure to install the firepot correctly may result in missed ignitions.

See Disposal of Ashes.

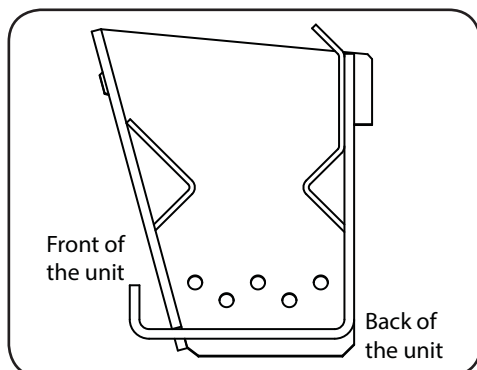
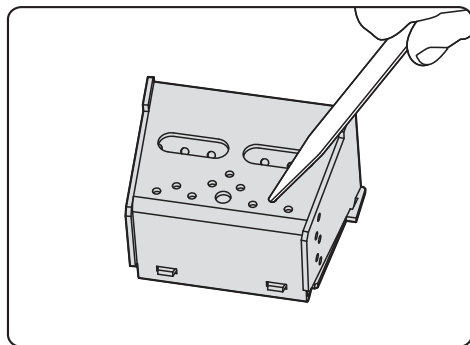
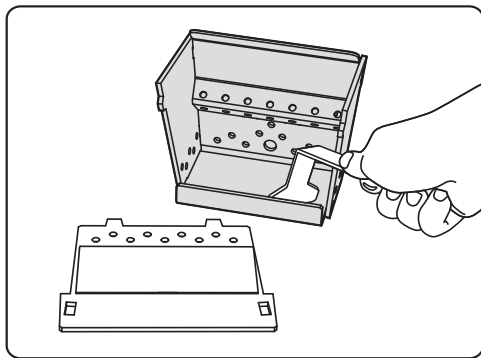

3. Ash Removal from Firebox

- **Frequency:** Weekly or more frequently depending on ash build-up.
 - **By:** Homeowner
- a. There must not be any hot ashes in the firebox during cleaning so allow the appliance to completely cool. The firebox ash should be removed every time the exhaust path is cleaned. Frequent cleaning of the ash in the firebox will help slow down the build-up of ash in the exhaust blower and vent system.
 - b. Vacuum out the firebox thoroughly on both sides of the firebox and the floor and ceiling. Remember to place the ash and debris into a metal or non-combustible container.

See Disposal of Ashes.

4. Disposal of Ashes

- **Frequency:** As needed
- **By:** Homeowner

Ashes should be placed in a metal container with a tight-fitting lid. The closed container of ashes should be placed on a non-combustible floor or on the ground, well away from all combustible materials, pending final disposal.

If the ashes are disposed of by burial in soil or otherwise locally dispersed, they should be retained in the closed container until all cinders have been thoroughly cooled.

WARNING



Disposal of Ashes

- Ashes should be placed in metal container with tight fitting lid.
- Ashes should be retained in closed container until all cinders have thoroughly cooled.

6. Cleaning the Glass

- **Frequency:** When clear view of the firepot becomes obscure
- **By:** Homeowner
 - a. Appliance must be completely cool before cleaning glass.
 - b. Vacuum fly ash from glass and door rope.
 - c. Use a damp paper towel or any non-abrasive glass cleaner. Wipe off with dry towel.

CAUTION



Handle glass assembly with care.

When cleaning glass:

- Do NOT use abrasive cleaners.
 - Do NOT clean glass when hot.
- Avoid striking, scratching or slamming glass.
 - Refer to maintenance instructions.
 - Do NOT operate with glass cracked, broken or scratched.

7. Cleaning the Hopper

- **Frequency:** Monthly or after burning 25 bags of fuel
- **By:** Homeowner

After burning approximately 25 bags of fuel you will need to clean the hopper to prevent sawdust build-up.

A combination of sawdust and pellets on the bottom end of the auger reduces the amount of fuel supply to the firepot or cause the feed system to jam. This can result in nuisance shutdowns and mis-starts.

- a. The appliance must be in complete shutdown. Allow the appliance to completely run out of pellets and cool down.
- b. Empty the hopper of any remaining pellets.
- c. Vacuum the hopper and feed tube. To access the feed tube remove the four screws from the auger cover located inside of the hopper.

NOTE: If the screws fall into the auger; manually turn the auger or use a magnet to retrieve the screws. DO NOT RUN THE UNIT IF SCREWS FALL IN THE AUGER!

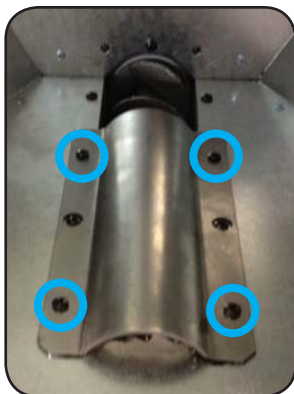

8. Cleaning the Exhaust Path, Baffles & Drop Tube

- **Frequency:** Monthly or every 25 bags or more frequently depending on ash build-up.
- **By:** Homeowner
 - a. Appliance must be completely cool.
 - b. Open the door and remove the center baffle first and then the right and left baffles. Do NOT remove the screws inside the baffles! Thoroughly vacuum the exhaust path and drop tube and continue throughout the rest of the firebox. Also vacuum the front and back of the baffles.
 - c. Using a small brush, brush the inner walls of the exhaust outlet from the access hole inside the firebox. The access hole will be visible following the removal of the left side baffle. After loosening up debris on the inner walls of the outlet, vacuum out.

This is important as the exhaust temperature probe is attached to the right side of the outlet. If this is not maintained on a regular basis, the appliance will experience nuisance shut downs and/or missed ignitions.
 - d. Replace the right and left baffles and then the center baffle and close and latch the door.

NOTE: Pelpro recommends using a heavy duty vacuum cleaner specifically designed for solid fuel appliance cleaning.

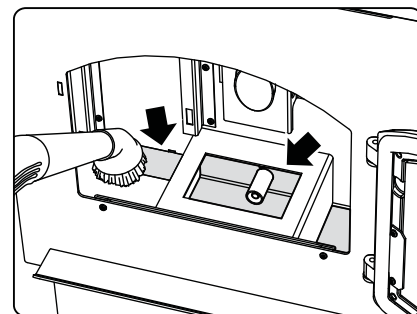
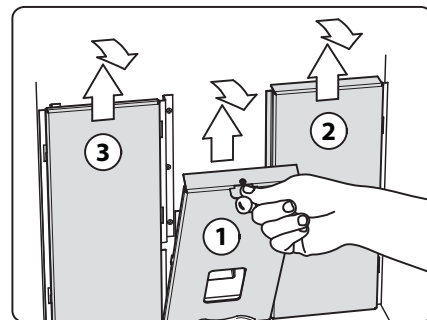

9. Door Gasket Inspection

- **Frequency:** Monthly or prior to heating season
- **By:** Homeowner

The gasketing between the glass and firebox should be inspected periodically to make sure there is a good seal.

10. Cleaning Convection Blower - Requires No Lubrication

- **Frequency:** Monthly depending on Dust/Dirt build-up
- **By:** Homeowner or Qualified Service Technician
 - a. Be sure the appliance is allowed to cool and has been unplugged.
 - b. Remove the right side panel
 - c. Remove the 2 nuts holding the blower to the convection plenum
 - d. Sweep or vacuum out any build-up on the impellers.
 - e. If required, unplug the blower wires and use a brush or compressed air to loosen dirt.
 - f. Plug the blower wires into their corresponding wire terminals.
 - g. Align the blower to the convection plenum and install 2 nuts.
 - h. Replace and secure the side panel

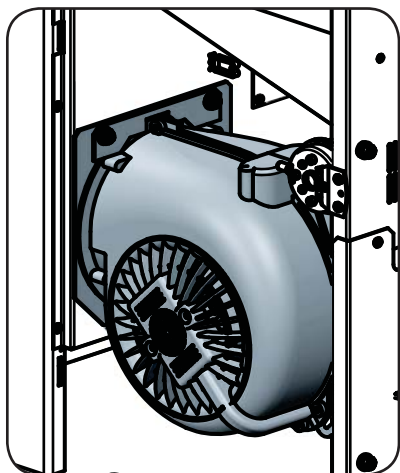

11. Cleaning Exhaust Blower - Requires No Lubrication

- **Frequency:** Yearly or more frequently depending on ash build-up
- **By:** Homeowner or Qualified Service Technician
 - a. Be sure the appliance is allowed to cool, has been unplugged and the exhaust blower is off.
 - b. Remove the left side panel. Detach the exhaust blower from the blue wires.
 - c. Loosen the six screws holding the exhaust blower motor to the housing and remove the motor. Using caution as to not damage the gasket when removing the blower. If damage occurs, install a new gasket available as a replacement part.
 - d. Vacuum the blower's impellers. Use care not to bend or damage the blower fins.
 - e. Using a brush or vacuum attachment, clean the inside of the exhaust outlet.
 - f. Reattach the motor and tighten screws. Make sure the wires are attached to the terminals on the blower.



12. Preparing Firebox for Non-Burn Season

- **Frequency:** Yearly
- **By:** Homeowner
 - a. Be sure the appliance is allowed to cool, has been unplugged and the exhaust blower is off.
 - b. Remove all ash from the firebox and vacuum thoroughly.
 - c. Paint all exposed steel, including cast-iron.
 - Purchase high temperature paint from your local retailer.
 - Must use a high-temperature paint made specifically for heating appliances.

13. Soot and Fly Ash: Formation & Need for Removal in Exhaust Venting System.

- **Frequency:** Yearly or more frequently depending on ash build-up.
- **By:** Qualified Service Technician/Homeowner

Be sure the appliance is allowed to cool, has been unplugged and the exhaust blower is off.

The products of combustion will contain small particles of fly ash. The fly ash will collect in the exhaust venting system and restrict the flow of the flue gases.

At start-up if there is incomplete combustion, or if there is a shutdown or incorrect operation of the appliance it will lead to some soot formation. This will collect in the exhaust venting system.

The venting (chimney) system may need to be cleaned at least once a year or more often depending upon the quality of your fuel or if there are any horizontal pipe sections. Ash will build up more quickly in the horizontal sections and elbows.

D. High Ash Fuel Content Maintenance

- **Frequency:** As needed
- **By:** Homeowner

Conditions that make the firepot fill quickly with ashes and clinkers and require higher maintenance for the appliance include:

- Poor quality pellet fuel.
- Lack of maintenance.
- Trim Dial is set to a less than optimum setting.

This condition makes the appliance susceptible to overfilling the firepot with pellets which may result in smoking, sooting and possible hopper fires. The figure below shows an example where the firepot overfills, pellets back up into the feed tube and ash has accumulated in the firebox.

An inefficient and non-economical method of burning of fuel caused by poor quality pellet fuel is shown below.

If the ash buildup exceeds the half way point in the firepot **IMMEDIATE ATTENTION AND CLEANING IS REQUIRED.**

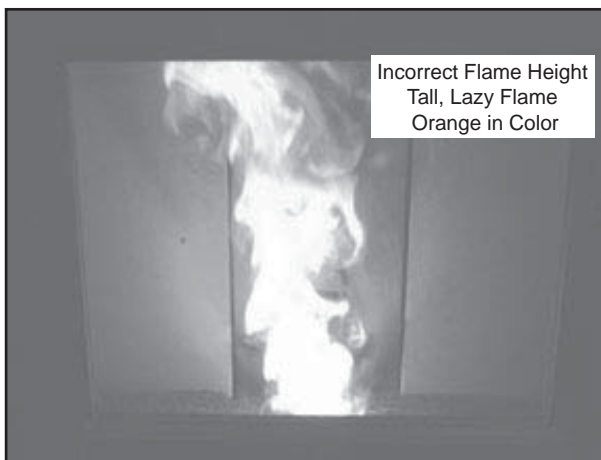
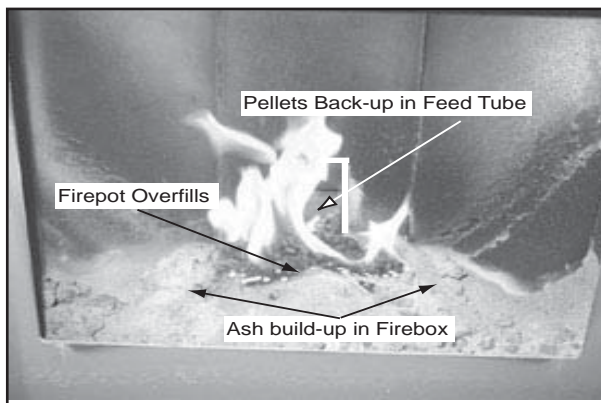

E. Frequently Asked Questions

What causes my glass to become dirty?

If the glass has white ash build up it is normal and the glass should be cleaned. If it is a black soot build up airflow thru the unit may be restricted. The most often cause is overdue maintenance and cleaning. See "Maintaining and Servicing Appliance" in the owner's manual and/or make adjustments to the trim control.

How can I get more heat out of the appliance?

The most often cause of diminished heat output is overdue maintenance and cleaning. See "Maintaining and Servicing Appliance" in the owner's manual.

What should I do if I smell smoke or there is ash/soot coming from the appliance?

While there will always be some smoke smell from wood burning appliances (including pellet) you should investigate all venting to make sure it is sealed properly. Most venting requires high-temperature silicone to seal the seams. In addition most homes are built very tight today and exhaust systems can create negative pressure in the home. See "Negative Pressure" under "Getting Started" in the owner's manual if you have checked the venting but still have smoke coming from the appliance. For ash or soot check the above and the exhaust blower housing and seals.

Why would my appliance run fine last winter but not start this fall?

It is possible that the stove was not properly prepared for the Non-burn season. See "Troubleshooting" in the owner's manual.

Why would the metal on the inside of the appliance begin to flake?

There are some pellet mills that get their raw materials from lumber mills that purchase logs that are transported in sea water. These pellets can have a higher salt content and cause the metals in the unit to corrode prematurely and deteriorate. If you are seeing any components inside the firebox deteriorate it is recommended to change pellet brands immediately.

Is there a place to lubricate the blowers to quiet them down?

The most often cause of noisy blowers is from the impellers becoming dirty over time. See "General Maintenance & Cleaning" under "Maintaining & Servicing Appliance" in the owner's manual. No form of lubrication should ever need applied to the blowers.

What is the metal object with the bend in it for that came inside the plastic bag?

It is a clean-out tool used to help clean the firepot and remove any jams in the rare event they occur in the feed tube.

Why is there a black residue building up on the outside of my home?

Wind can cause this to happen. If the appliance is operating correctly very little soot should ever exit the termination cap. Also check to be sure the venting is installed per the owner's manual and local codes.

Do I need an outside air kit?

Outside air is required for mobile home installs and in some jurisdictions. Refer to "Listing & Code Approvals", "Mobile Home Installation" and "Appliance Set-up" owner's manual. Also refer to local building codes.

I am seeing sparks coming out of my pipe (termination cap) outside is this safe?

This is normal. As long as clearances to combustibles were followed this is safe.

I have no power to anything. Does this unit have a circuit breaker or fuse or a reset button?

If the control board fuse is blown, the circuit board will need to be replaced – refer to the service section for replacement.

Can I burn corn in my unit?

NO, corn is not an approved fuel.

Where is the serial # of my unit is located?

The serial # is located on the back of the stove.

5 Replacement Parts

A. Convection Blower Replacement

1. Turn the dial control to the off position. Unplug the power to the unit.
2. Remove the right side panel by loosening the three screws attaching it to the back of the appliance.
3. Using a 7/16 wrench or socket, remove the 2 nuts holding the blower to the convection plenum
4. Lower the back of the blower and lift out.
5. With the blower removed, unplug its wires from the wire harness.
6. Remove the screws holding the retainer plate to the convection blower housing.
7. To replace, put the bottom lip of the blower into the lower slot. Attach the top of the blower to nuts. Reattach the metal plate and screw nuts into bolts.
8. Attach wires to wire harness.
9. Attach the right side panel and tighten screws.

B. Exhaust Blower Replacement

1. Turn the dial control to the off position. Unplug the power to the unit.
2. Remove the left side panel by loosening the three screws attaching it to the back of the appliance.
3. Disconnect 2 white wires from the blue wires of the exhaust blower.
4. Remove the blower motor attached to a removable plate on the exhaust blower. Depending on the model, use a 1/4 inch socket, or 1/4 inch Nut Driver or #2 Phillips Head screw driver to loosen the 6 screws in the keyhole shaped holes and rotate the plate. It is only necessary to loosen screws.
5. Remove the exhaust blower and gasket.
6. Check for degradation on the gasket and replace if necessary using the gasket included in the kit.
7. Re-install in reverse order.

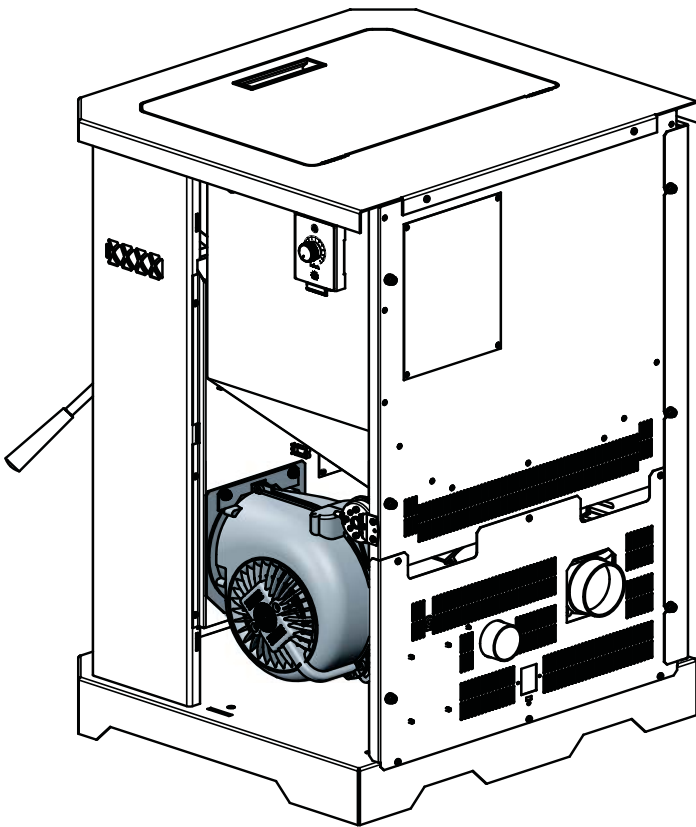

C. Snap Disc Replacement

Power - Manual Reset

1. Turn the dial control to the off position. Unplug the power to the unit.
2. Using #2 Phillips screwdriver, loosen the bolts on the rear of the unit holding on the left side panel. You do not need to remove the screws. Remove side panel by lifting up and out.
3. Locate the snap disk on the top side of the feed tube where it meets the hopper. Disconnect the wire leads from the snap disk.
4. Using a #1 Phillips screwdriver, remove two 6-32 fasteners retaining the snap disk onto the side of the feed tube.
5. Using the same fasteners, attach the new snap disk. Attach the wire leads.
6. Restore power.

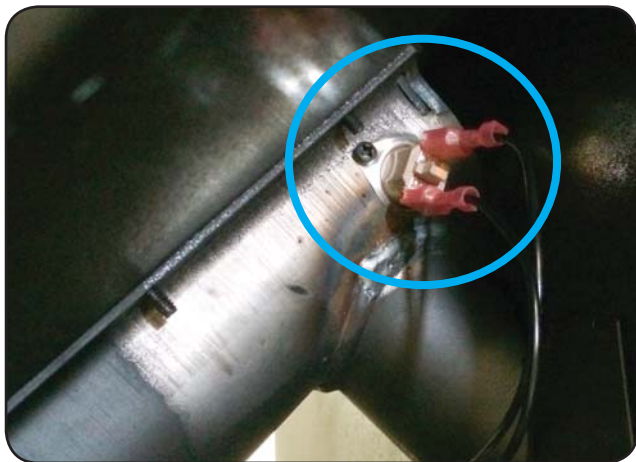

D. Igniter Replacement

1. Turn the dial control to the off position. Unplug the power to the unit.
2. Remove the right side panel & unplug the wire leads to the igniter.
3. Remove the screw in the top of the igniter chamber. Pinch the ends of the bracket together and pull the igniter straight out of the igniter chamber.
4. If there is difficulty in removing the igniter from the chamber, the chamber can be removed from the rear of the firebox by removing the 1/4-20 bolt using 3/8" socket.
5. Re-install the new igniter into the chamber using the bracket. Replug wires into terminals.
6. Inspect the igniter from the front of the unit by removing the firepot and looking into the end of the chamber. **MAKE SURE THE IGNITER IS CENTERED IN THE CHAMBER.**



E. Baffle Removal & Replacement

1. Turn the dial control to the off position. Make sure the unit is cool.
2. Remove the center baffle first by using the handle at the top of the baffle and pull up and then towards you. The hooks on the baffle will slide out of the slots in the bracket.
3. Remove the left baffle and then the right baffle by pulling up and then towards you. The left and right baffles have similar hooks and slots.

F. Glass Replacement

1. Open the door from the appliance by lifting door off of hinge pins and lay on a flat surface face down.
2. Using a Phillips Head screw driver, remove the 2 brackets and set aside.
3. Remove old glass and replace with the new glass.
4. Re-install the brackets using the same screws.



WARNING



- Glass is 5mm thick high temperature heat-resistant ceramic glass.
- DO NOT REPLACE with any other material.
- Alternate material may shatter and cause injury.

G. Feed Motor Replacement

1. Turn the dial control to the off position and unplug the unit. Remove the right side panel from the unit.
2. Unplug the connector from the feed motor.
3. Using pliers, remove the cotter pin.
4. Remove the feed motor from the feed shaft.
* NOTE: May need to pry using screw driver.
5. Reinstall the new feed motor by aligning the clearance hole in the feed motor shaft with the auger spring shaft and re-install the cotter pin.
6. Plug the feed motor leads back in and restore power.

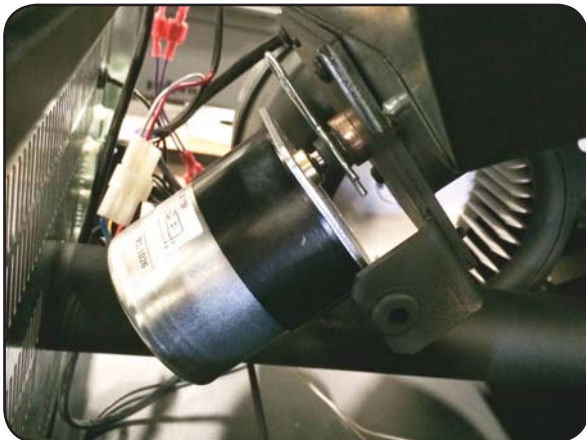

H. Feed Spring Replacement

1. Empty the hopper of all pellets. then follow the steps to remove the feed motor above.
2. Remove the four screws holding the feed motor bracket on.
3. Slide the auger assembly out from the bottom in the rear of the unit.
4. Inspect the bronze bearings, replace if needed.
5. Install new spring assembly following reverse steps including reattaching the feed motor.

I. Control Board Replacement

1. Turn the dial control to the off position. Unplug the power to the unit.
2. Unplug the wires from the control board. The connectors are locking connectors. Pinch the release tab on each connector and gently tug and rock loose.
3. Pinch the 4 plastic pins from the rear of the unit with needle nose pliers to release the control board connectors.
4. Install new board following the steps in reverse.



J. Fuse Replacement

1. Turn the dial control to the off position. Unplug the power to the unit.
2. Pull the plastic fuse holder cover off the control board.
3. Replace fuse with 5AMP 120VAC fuse only.
4. Replace the cover on the fuse holder and restart unit.

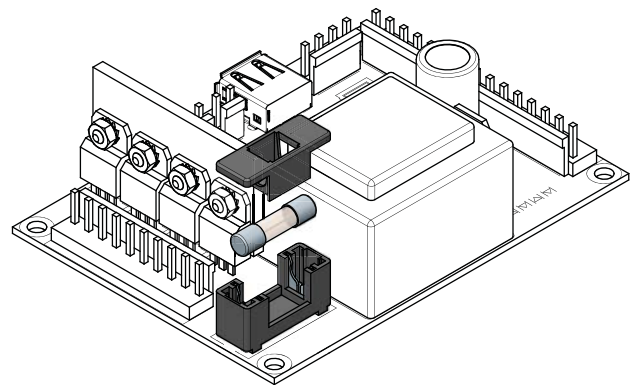

6 Getting Started

A. Design, Installation & Location Considerations

NOTICE: Check building codes prior to installation.

- Installation **MUST** comply with local, regional, state and national codes and regulations.
- Consult insurance carrier, local building inspector, fire officials or authorities having jurisdiction over restrictions, installation inspection and permits.

Since pellet exhaust can contain ash, soot or sparks, you must consider the location of:

- Windows
- Air Intakes
- Air Conditioner
- Overhang, soffits, porch roofs, adjacent walls
- Landscaping, vegetation

When locating vent and venting termination, vent above roof line when possible.

NOTICE: Locating the appliance in a location of considerable air movement can cause intermittent smoke spillage from appliance. Do not locate appliance near:

- Frequently open doors
- Central heat outlets or returns

B. Draft

Draft is the pressure difference needed to vent appliances successfully. When an appliance is drafting successfully, all combustion by products are exiting the home through the chimney.

Considerations for successful draft include:

- Preventing negative pressure
- Location of appliance and chimney

To measure the draft or negative pressure on your appliance use a manahelic or a digital pressure gauge capable of reading 0 - .25 inches of water column (W.C.). Using a 1/8" tee connector, connect the manahelic to the vacuum hose behind the right side panel.

The appliance should be running on high for at least 15 minutes for the test.

With the stove running on high you should have a negative pressure equal to or greater than the number given in the chart. If you have a lower reading than you find on the chart, your stove does not have adequate draft to burn the fuel properly.

MODEL	Minimum Vacuum Requirements
PP130	0.17 inches W.C.

Draft (Cont'd)

Correct low draft or low vacuum problems by doing one of the following:

- Thoroughly clean the exhaust path and venting. See Maintenance Section.
- Inspect for worn or broken gaskets. Repair any gaskets suspected of leaking, or adjust the trim.

NOTICE: Pelpro assumes no responsibility for the improper performance of the chimney system caused by:

- Inadequate draft due to environmental conditions
- Downdrafts
- Tight sealing construction of the structure
- Mechanical exhausting devices

C. Negative Pressure

Negative pressure results from the imbalance of air available for the appliance to operate properly. It can be strongest in lower levels of the house.

Causes include:

- Exhaust fans (kitchen, bath, etc.)
- Range hoods
- Combustion air requirements for furnaces, water heaters and other combustion appliances
- Clothes dryers
- Location of return-air vents to furnace or air conditioning
- Imbalances of the HVAC air handling system
- Upper level air leaks such as:
 - Recessed lighting
 - Attic hatch or open windows
 - Duct leaks

To minimize the effects of negative air pressure:

- Install the outside air kit with the intake facing prevailing winds during the heating season
- Ensure adequate outdoor air for all combustion appliances and exhaust equipment
- Ensure furnace and air conditioning return vents are not located in the immediate vicinity of the appliance
- Avoid installing the appliance near doors, walkways or small isolated spaces
- Recessed lighting should be a "sealed can" design
- Attic hatches weather stripped or sealed
- Attic mounted duct work and air handler joints and seams taped or sealed



WARNING

Risk of Asphyxiation!

Negative pressure can cause spillage of combustion fumes and soot.

D. Locating Your Appliance & Chimney

Location of the appliance and chimney will affect performance.

- Install through the warm airspace enclosed by the building envelope. This helps to produce more draft, especially during lighting and die-down of the fire.
- Penetrate the highest part of the roof. This minimizes the affects of wind loading.
- Locate termination cap away from trees, adjacent structures, uneven roof lines and other obstructions.
- Minimize the use of chimney offsets.
- Consider the appliance location relative to floor and ceiling and attic joists.
- Take into consideration the termination requirements.

F. Tools And Supplies Needed

Tools and building supplies normally required for installation, unless installing into an existing masonry fireplace:

- | | |
|----------------------------------|------------------------------|
| Reciprocating Saw | Gloves |
| Channel Locks | Safety Glasses |
| Hammer | Framing Square |
| Phillips Screwdriver | Electric Drill & Bits (1/4") |
| Tape Measure | 1/4" Self-Tapping Screws |
| Plumb Line | |
| Level | <u>May also need:</u> |
| Framing Material | Vent Support Straps |
| Non-combustible Sealant Material | Venting Paint |

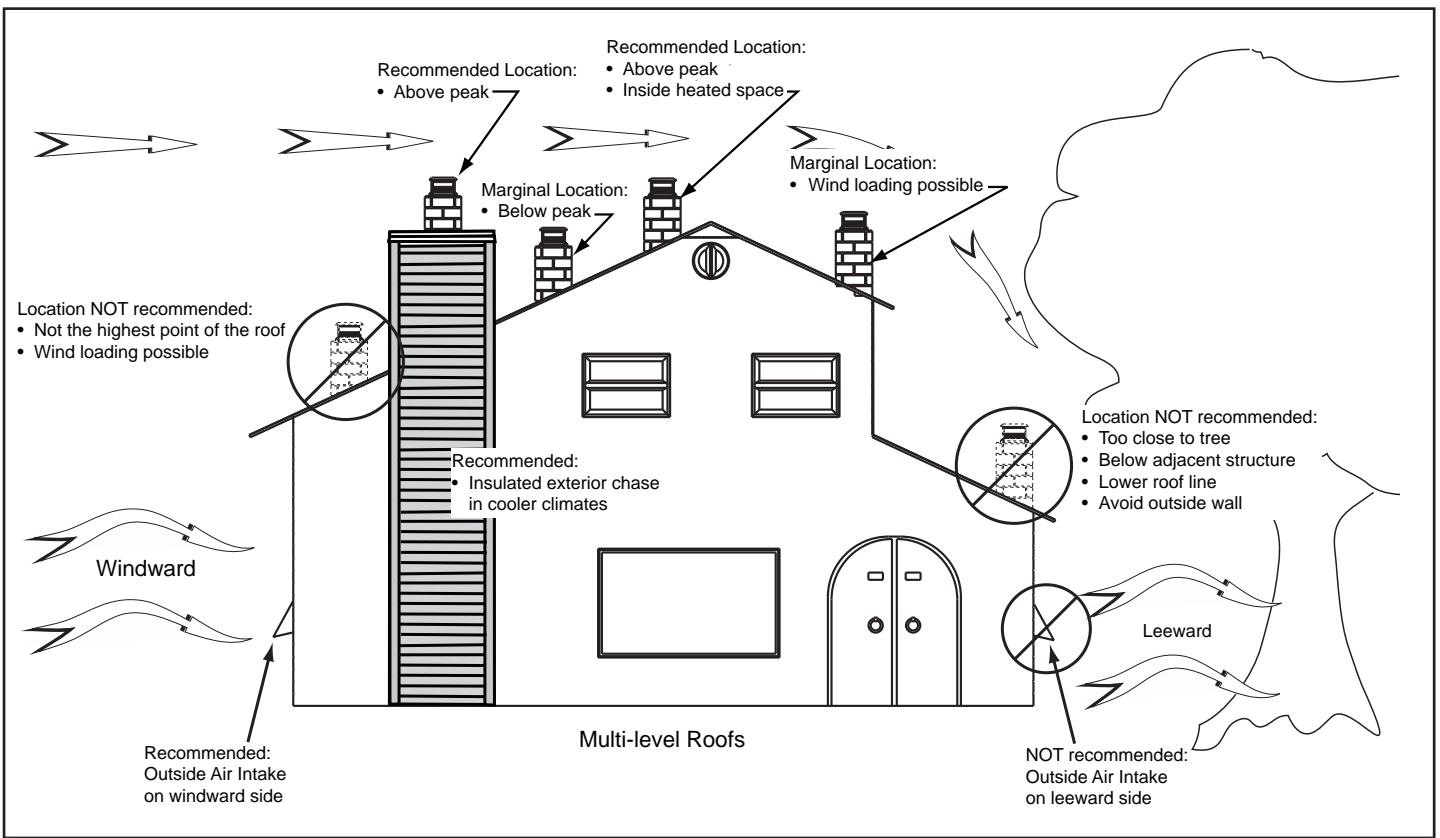

E. Inspect Appliance & Components

- Remove appliance and components from packaging and inspect for damage.
- Report to your dealer any parts damaged in shipment.
- **Read all the instructions before starting the installation. Follow these instructions carefully during the installation to ensure maximum safety and benefit.**

WARNING



Inspect appliance and components for damage. Damaged parts may impair safe operation.

- Do NOT install damaged components.
- Do NOT install incomplete components.
- Do NOT install substitute components.

Report damaged parts to dealer.

7 Dimensions and Clearances

MODEL: PP130

A. Appliance Dimensions

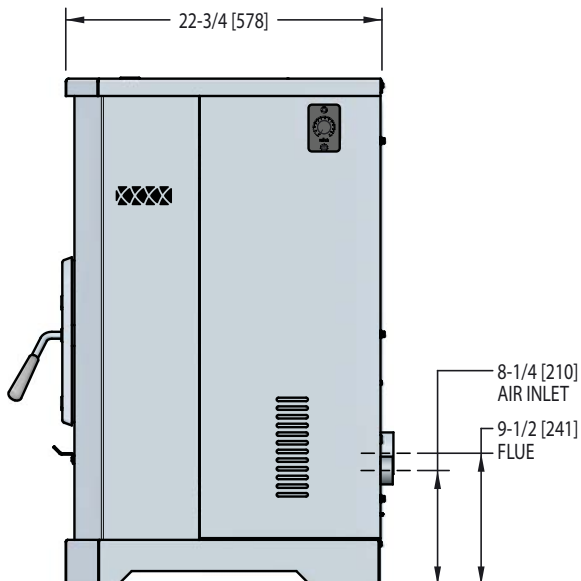
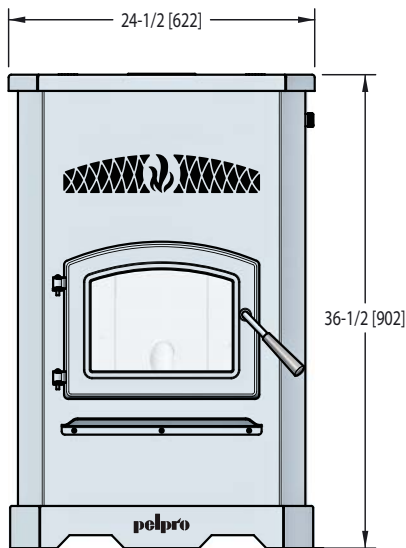
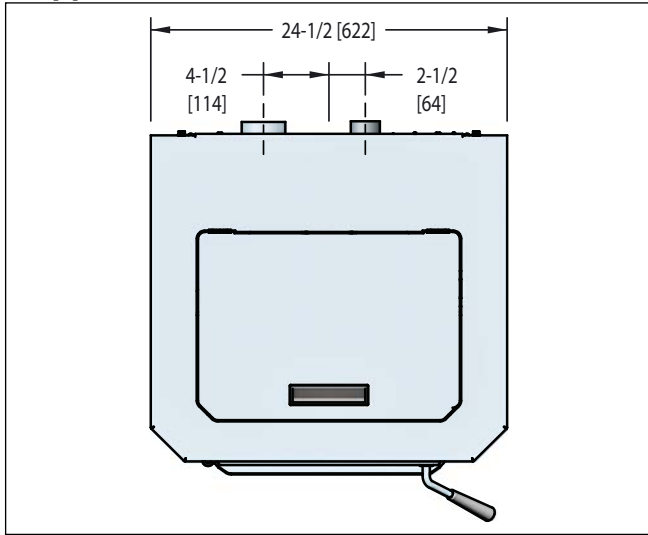

B. Clearances to Combustibles (UL and ULC)

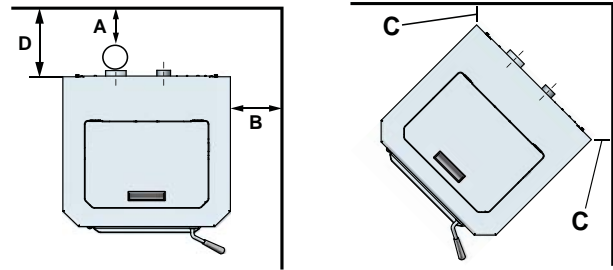

Vertical Installations (Interior Flue)			
Straight Back Against Wall		Inches	Millimeters
A	Back Wall to Flue Pipe	3	76
B	Side Wall to Appliance	13	330

Corner Installation		Inches	Millimeters
C	Walls to Appliance	3	76

Horizontal Flue Installations			
Straight Back Against Wall		Inches	Millimeters
D	Back Wall to Appliance	2	51
B	Side Wall to Appliance	13	330

CAUTION

- DO NOT CONNECT THIS UNIT TO A CHIMNEY FLUE SERVICING ANOTHER APPLIANCE.
- DO NOT CONNECT TO ANY AIR DISTRIBUTION DUCT OR SYSTEM.

WARNING



HOT SURFACES!

Glass and other surfaces are hot during operation AND cool down.

Hot glass will cause burns.

- Do not touch glass until it is cooled
- NEVER allow children to touch glass
- Keep children away
- CAREFULLY SUPERVISE children in same room as fireplace.
- Alert children and adults to hazards of high temperatures.

High temperatures may ignite clothing or other flammable materials.

- Keep clothing, furniture, draperies and other flammable materials away.

C. Hearth Pad Requirements (UL and ULC)

Use a non-combustible floor protector, extending beneath appliance and to the front, sides and rear as indicated. Measure front distance "M" from the surface of the glass door.

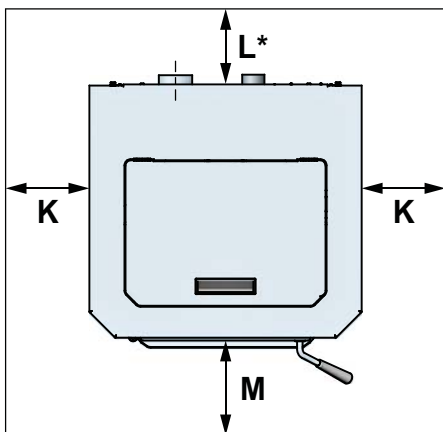

USA Hearth Pad Requirements

Hearth Pad Requirements		Inches
K	Sides	2
L*	Back	2
M	Front	6

Canada Hearth Pad Requirements

Hearth Pad Requirements		Millimeters
K	Sides	203
L*	Back	51
M	Front	152

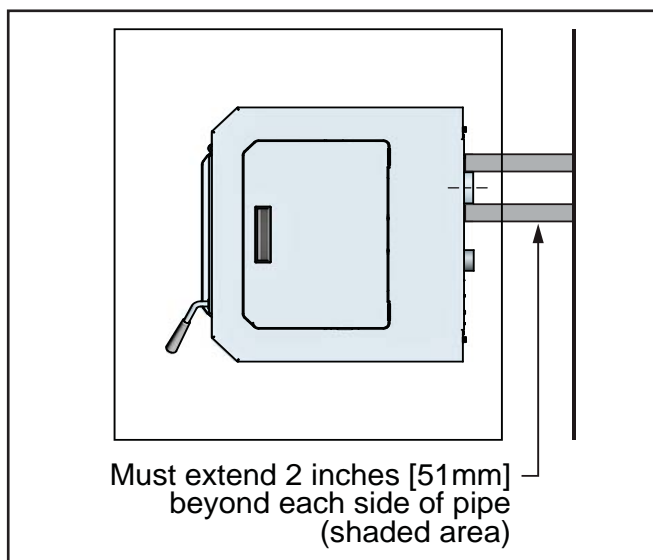



***C: Exception for Horizontal Installations:**

CANADA INSTALLATIONS: A non-combustible floor protection extending beneath the flue pipe is **required** with horizontal venting or under the top vent adapter with vertical installation.

USA INSTALLATIONS: A non-combustible floor protection extending beneath the flue pipe is recommended with horizontal venting or under the top vent adapter with vertical installation.

A non-combustible floor protector is required.

 **WARNING**

 **If the information in these instructions is not followed exactly, a fire may result causing property damage, personal injury, or death.**

- Do not store or use gasoline or other flammable vapors and liquids in the vicinity of this or any other appliance.
- Do not over fire - If heater or chimney connector glows, you are over firing. Over firing will void your warranty.
- Comply with all minimum clearances to combustibles as specified. Failure to comply may cause house fire.

8 Vent Information



A. Chimney and Exhaust Connection



1. **Chimney & Connector:** Use 3 or 4 inch (76-102mm) diameter type “L” or “PL” venting system. It can be vented vertically or horizontally.
2. **Mobile Home:** Approved for all Listed pellet vent. If using the 3 inch (76mm) vertical Top Vent Adapter Kit or the 3 to 6 inch (76-152mm) Top Vent Offset Adapter, use Listed double wall flue connector. An authorized Outside Air Kit must be used with manufactured home installations.

Canada factory built, chimney installations requires installation to conform with CAN/ULC-S629.

3. **Residential:** The 3 inch (76mm) vertical Top Vent Adapter Kit and the 3 to 6 inch (76-152mm) Top Vent Offset Adapter are tested to use 24 gauge single wall flue connector or Listed double wall flue connector to Class A Listed metal chimneys, or masonry chimneys meeting International Conference of Building Officials (ICBO) standards for solid fuel appliances.
4. **INSTALL VENT AT CLEARANCES SPECIFIED BY THE VENT MANUFACTURER.**
5. Secure exhaust venting system to the appliance with at least 3 screws or rivets per the pipe manufacturer’s instructions. Also secure all connector pipe joints with at least 3 screws through each joint. The chimney connection must be in good condition and kept clean.
6. DO NOT INSTALL A FLUE DAMPER IN THE EXHAUST VENTING SYSTEM OF THIS UNIT.
7. DO NOT CONNECT THIS UNIT TO A CHIMNEY FLUE SERVING ANOTHER APPLIANCE.

NOTE: All pipe must be welded seam pipe whenever possible. Seal pipe joints with high temperature silicone (500°F [260°C] minimum rated only). Do not put silicone inside of pipe.

 WARNING	
	Fire Risk Follow Chimney Connector Manufacturer’s Instructions for Proper Installation. ONLY use connector: <ul style="list-style-type: none">• Within the room, between appliance & ceiling or wall
	Connector shall NOT pass through: <ul style="list-style-type: none">• Attic or roof space• Closet or similar concealed space• Floor or ceiling Maintain minimum clearances to combustibles

 WARNING	
	Vent surfaces get HOT, can cause burns if touched. Non-combustible shielding or guards may be required.

B. Venting Termination Requirements

CAUTION
Do not terminate vent in any enclosed or semi-enclosed area such as a carport, garage, attic, crawl space, under a sun deck or porch, narrow walkway or closely fenced area, or any location that can build up a concentration of fumes such as a stairwell, covered breezeway, etc.

1. Termination must exhaust above air inlet elevation. **It is strongly recommended that at least 60 inches (1.5m) of vertical pipe be installed when appliance is vented directly through a wall.** This will create a natural draft, which will help prevent the possibility of smoke or odor venting into the home during a power outage. It will also keep exhaust from causing a nuisance or hazard by exposing people or shrubs to high temperatures. The safest and preferred venting method is to extend the vent vertically through the roof.
2. Distance from doors and opening windows, or gravity or ventilation air inlets into building:
 - a. Not less than 48 inches (1.2m) below;
 - b. Not less than 48 inches (1.2m) horizontally from;
 - c. Not less than 12 inches (305mm) above.
3. Distance from permanently closed windows;
 - a. Not less than 12 inches (305mm) below; horizontally from or above.
4. Distance between bottom of termination and grade should be 12 inches (305mm) minimum. This is conditional upon plants in the area, and nature of grade surface. The grade surface must be a non-combustible material (i.e., rock, dirt). The grade surface must not be lawn. Distance between bottom of termination and public walkway should be 7 feet (2.13m) minimum.
5. Distance to combustible materials must be 24 inches (610mm) minimum. This includes adjacent buildings, fences, protruding parts of the structure, roof overhang, plants and shrubs, etc.
6. Termination Cap Location (Home Electrical Service)
 - Side-to-side clearance is to be the same as minimum clearance to vinyl inside corners.
 - Clearance of a termination cap below electrical service shall be the same as minimum clearance to vinyl soffits.
 - Clearance of a termination cap above electrical service will be 12 inches (305mm) minimum.
 - Location of the vent termination must not obstruct or interfere with access to the electrical service.

C. Pellet Venting Charts

The maximum horizontal venting allowed with no vertical venting attached is 48 inches (1219mm) including one 90° elbow or two 45° elbows. This is our recommended horizontal venting installation. Addition of any horizontal venting beyond 48 inches (1219mm) requires a minimum 60 inches (1524mm) of additional vertical vent. Horizontal sections of vent pipe should have a 1/4 inch (6.35mm) rise per foot.

Pelpro recommends any installation requiring more than two 90° elbows, or more than 15 feet (4.5m) of venting to use 4 inch (102mm) vent.

45° elbow is equivalent to 1 foot of straight pipe

90° elbow is equivalent to 3 feet of straight pipe

ONE 90° ELBOW		
Total Horizontal	Minimum Vertical	Vent Diameter
4	0	3
5	5	3
6	6	3
7	7	3
8	8	4
9	9	4
10	10	4
11	11	4
12	12	4
13	13	4
14	14	4
15	15	4
16	16	4
17	17	4
18	18	4
19	19	4

TWO 90° ELBOWS		
Total Horizontal	Minimum Vertical	Vent Diameter
2	5	3
3	6	3
4	7	3
5	8	3
6	9	3
7	10	4
8	11	4
9	12	4
10	13	4
11	14	4
12	15	4
13	16	4
14	17	4
15	18	4

THREE 90° ELBOWS		
Total Horizontal	Minimum Vertical	Vent Diameter
2	11	4
3	12	4
4	13	4
5	14	4
6	15	4
7	16	4
8	17	4
9	18	4
10	19	4
11	20	4



WARNING



Fire Risk

- Only LISTED venting components may be used.
- NO OTHER vent components may be used. Substitute or damaged vent components may impair safe operation.

NOTICE: These are guidelines for successful venting of your pellet appliance. The more vertical rise you can obtain in your system, the better it will perform. Horizontal vent runs can accumulate ash and will need to be cleaned more often. Try to keep them as short as possible.

Minimum Vertical Vent for One Elbow

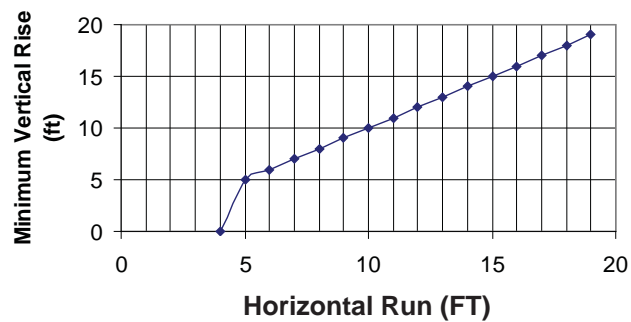

Minimum Vertical Vent for Two Elbows

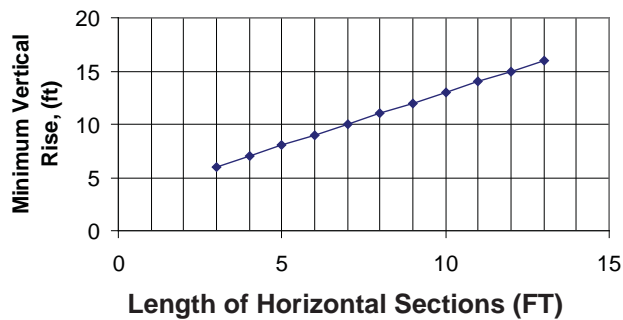

Minimum Vertical Vent for Three Elbows

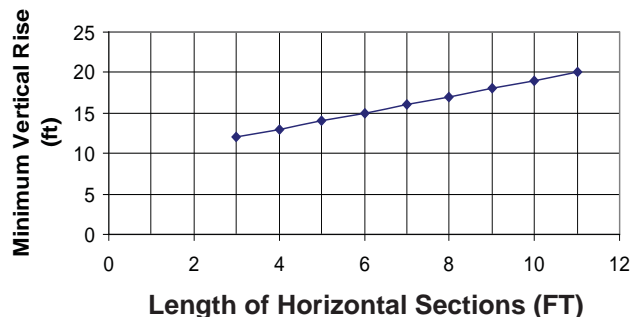

9 Venting Systems

A. Vertical - Interior - Typical Installation

PREFERRED METHOD #1

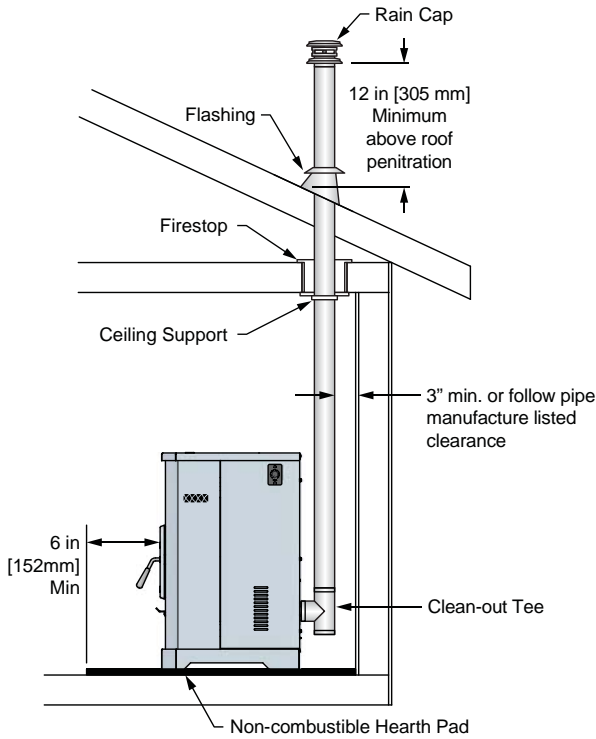

C. Vertical into Existing Class A Chimney

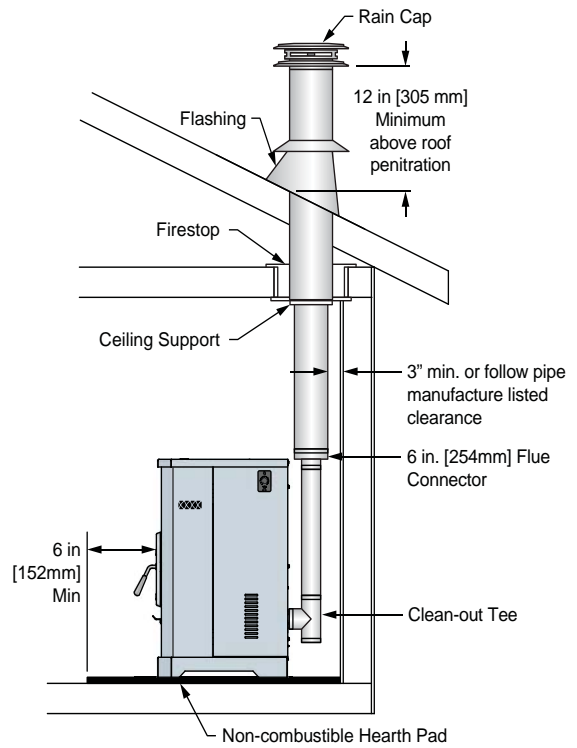

B. Through The Wall & Vertical - External - Horizontal

PREFERRED METHOD #2

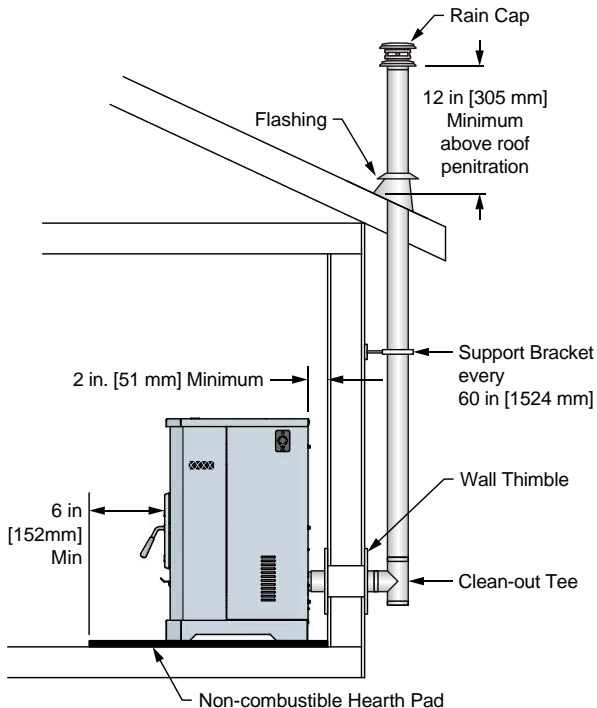

We strongly recommend a minimum of 60 inches (1.5m) vertical, however above the eave is preferred.

Both installations are approved for mobile home installations. Must use 3 or 4 inch (76 to 102mm) "L" or "PL" Listed pellet venting or Listed double wall pipe and authorized Outside Air Kit in mobile homes. Single wall pipe is approved for residential installations only.

Air Clearance to Pipe:

This appliance was tested with standard 3 inch (76mm) Listed pellet vent.

Pellet pipe manufacturers Listed reduced clearance pipe may be use for reduce clearance from 3 inch (76mm) air clearance to no less than 1 inch (25mm) air clearance to combustibles for approved Listed pellet pipe.

Follow pipe manufactures listed air clearances to combustibles and installation instructions for all reduced air clearances installations.

⚠ WARNING



Fire Risk

Inspection of Chimney:

- Masonry chimney must be in good condition.
- Meets minimum standard of NFPA 211
- Factory-built chimney must be minimum 6 inch (152mm) UL103 HT.

⚠ WARNING

Improper installation, adjustment, alteration, service or maintenance can cause injury or property damage. Refer to the owner's information manual provided with this appliance. For assistance or additional information consult a qualified installer, service agency or your dealer.

D. Masonry

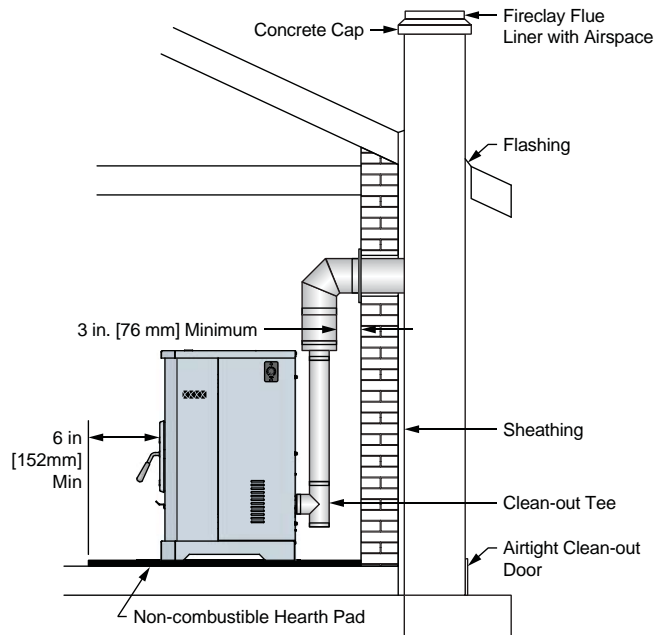

E. Alternate Masonry

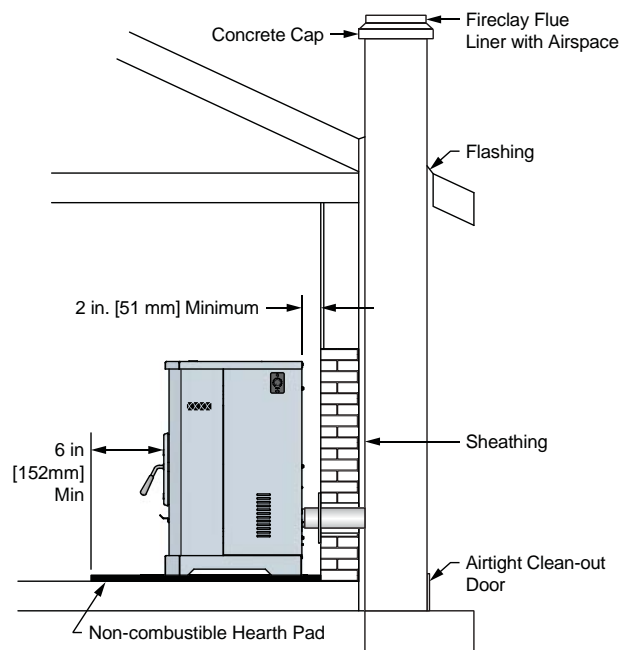

F. Through The Wall

Horizontal termination cap must be a minimum of 6 inches (152mm) from the wall. Approved for mobile home installations. Must use 3 or 4 inch (76-102mm) "L" or "PL" listed pellet venting or Listed double wall pipe and an authorized Outside Air Kit in mobile homes.

In Canada, where passage through a wall or partition of combustible construction is desired, the installation shall conform to CAN/CSA-B365

NOTICE: Please note that while the minimum clearance for the termination cap is 6 inches (152mm) there is the possibility of soot build-up around the termination area. If this occurs we suggest to move the termination further away from the house to prevent it. The suggested minimum is 12 inches.

CAUTION

DO NOT DOWNWARD VENT.

The following will occur:

- The appliance will not vent properly
- Smoke spillage in the house
- Excessive sooting

Straight Out

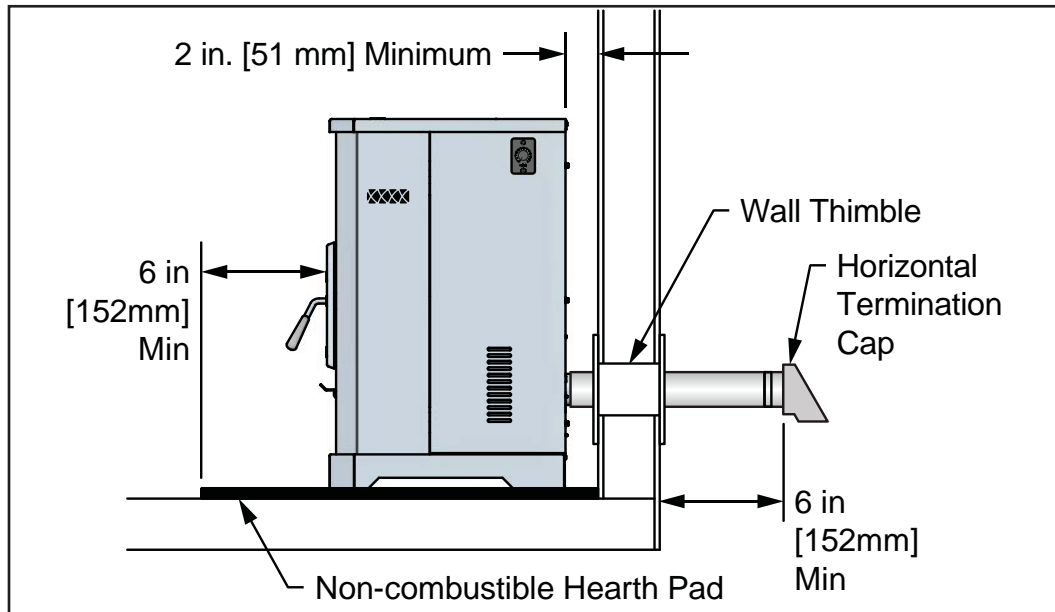

45 Degree

Illustration shows venting going in both directions. Choose which one is best for your installation.

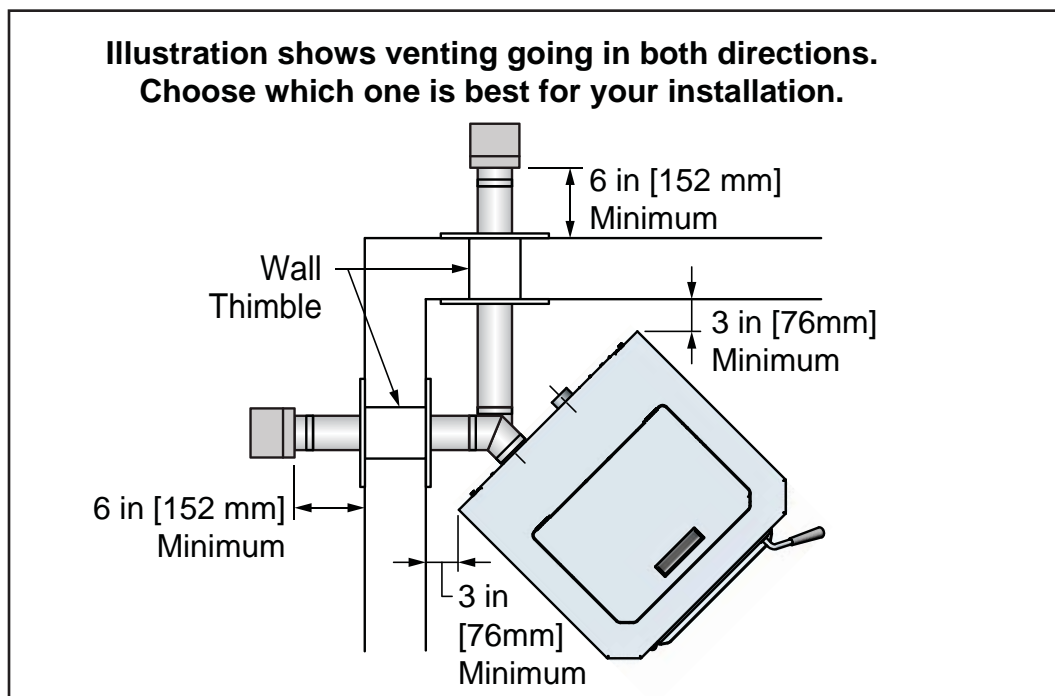

10 Mobile Home

A. Mobile Home Installation

You must use an authorized Outside Air Kit for installation in a mobile home.

1. An outside air inlet must be provided for the combustion air and must remain clear of leaves, debris, ice and/or snow. It must be unrestricted while the appliance is in use to prevent room air starvation which causes smoke spillage. Smoke spillage can also set off smoke alarms.
2. The combustion air duct system must be made of metal. It must permit zero clearance to combustible construction and prevent material from dropping into the inlet or into the area beneath the dwelling and contain a rodent screen.
3. The appliance must be secured to the mobile home structure by bolting it to the floor (using lag bolts) with two attachment points. Use the holes in the appliance base.
4. Ground wire to be connected directly to the frame of the manufactured home.
5. Refer to Clearances to Combustibles and floor protection requirements for listings to combustibles and appropriate chimney systems.
6. Use silicone to create an effective vapor barrier at the location where the chimney or other component penetrates to the exterior of the structure.
7. Follow the chimney manufacturer's instructions when installing the vent system for use in a mobile home.
8. Installation shall be in accordance with the Manufacturers Home & Safety Standard (HUD) CFR 3280, Part 24.

CAUTION

THE STRUCTURAL INTEGRITY OF THE MOBILE HOME FLOOR, WALL AND CEILING/ROOF MUST BE MAINTAINED

Do NOT cut through:

- Floor joist, wall, studs or ceiling trusses.
- Any supporting material that would affect the structural integrity.

CAUTION

Never draw outside combustion air from:

- Wall, floor or ceiling cavity
- Enclosed space such as an attic, garage or crawl space.

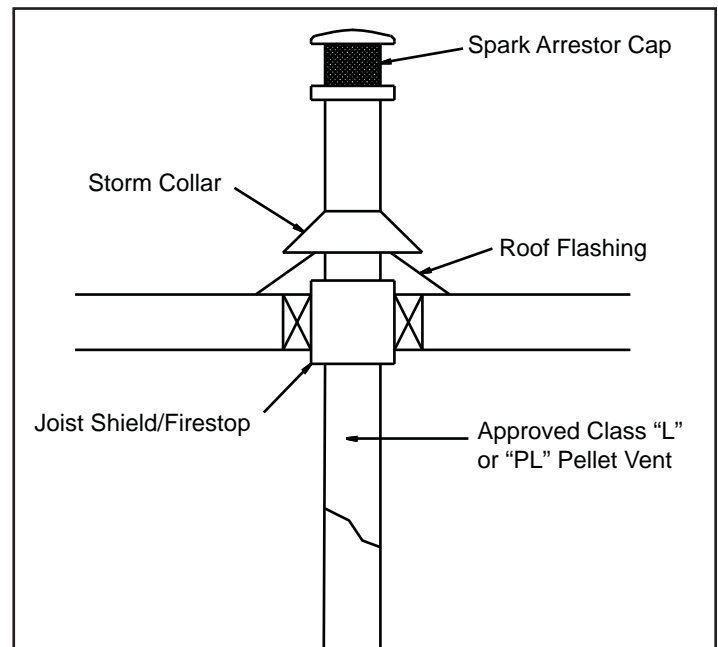

WARNING

Installation must comply with Manufactured Home and Safety Standard (HUD), CFR 3280, Part 24.

WARNING



Asphyxiation Risk

NEVER INSTALL IN A SLEEPING ROOM.
Consumes oxygen in the room.

11 Appliance Set-Up

A. Removal From Pallet

1. Remove 2 lag bolts from pallet.
2. Remove side panels.
3. Pull brackets out from base.
4. Reattached side panels.

B. Outside Air Kit Instructions

An outside air kit has been provide standard with the appliance. It is highly recommended to use the outside air kit for maximum performance and to reduce effects from negative pressure in the home.

Using the hose clamp, attach the flex pipe to the 2" outside air tube on the back of the appliance. Route the tube outside the structure, attach the cap and secure to outside wall using appropriate fasteners.

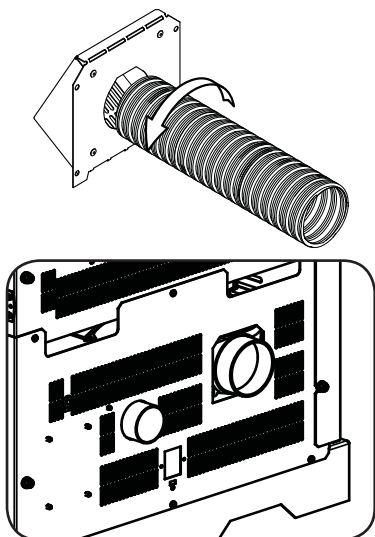

CAUTION

Never draw outside combustion air from:

- Wall, floor or ceiling cavity
- "Enclosed space such as an attic, garage or crawl space.

C. Power up the Unit

Plug the unit into 120VAC power.



CAUTION



Shock hazard

- Do NOT remove grounding prong from plug.
- Plug directly into properly grounded 3 prong receptacle.
- Route cord away from appliance.
- Do NOT route cord under or in front of appliance.



WARNING



DISCONNECT SUPPLY BEFORE SERVICING.

D. Hopper Extension (Optional Accessory)

1. Remove 2 screws from hopper lid. Remove lid (Beware of the hopper switch when removing).
2. Loosen bolts on back of unit & remove side panels.
3. Once side panels have been removed, install metal brackets on outside of unit. Figure 31.2
4. Remove side panels off hopper extension.
5. Attach hopper extension & snap into place. Figure 31.3
6. Reattach hopper extension side panels.
7. Attach hopper lid and rescrew into place.

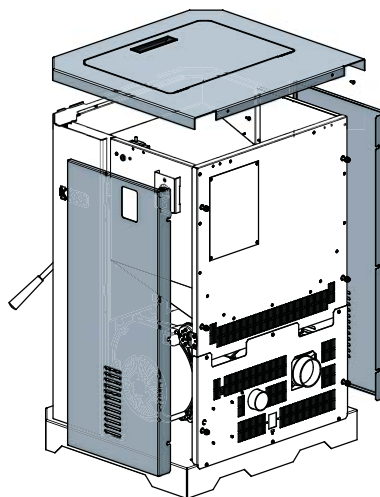

Figure 31.1

Figure 31.2

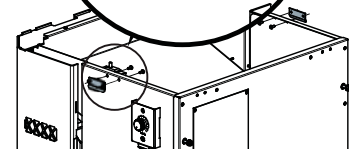
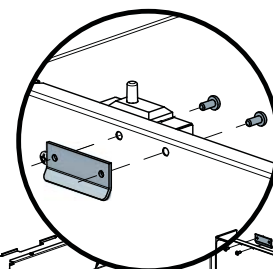
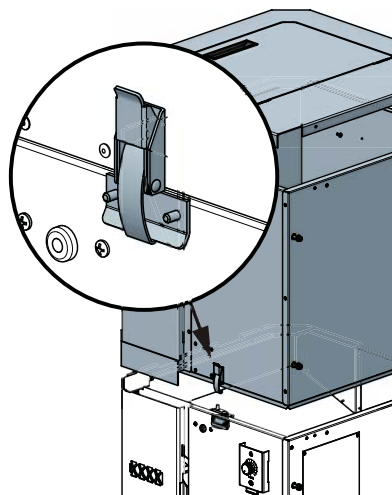

Figure 31.3



12 Troubleshooting

Symptom	Possible Cause	Corrective Action
Plug in appliance - No response.	No Power to outlet. 5 amp fuse defective or blown Snap disc tripped or defective.	Check circuit breaker at service panel. Find and repair the short circuit source, then replace the Control Board. Reset or replace snap disc.
Unit Will Not Light	No Fuel Out of fuel. Vacuum switch not closing, no vacuum. Hopper lid open. Defective hopper switch. Feed System is Jammed Feed motor not plugged in No Igniter Igniter not plugged in Igniter not centered Igniter defective Firepot Plugged Firepot dirty Firepot in backwards Too much debris in the bottom of the firepot	Check hopper. Fill with fuel. Check exhaust blower is plugged in and operating. Check vacuum switch is plugged in Check vacuum hose is in good condition clear and connected at both ends Make sure venting system is clean Make sure front door is closed Check vacuum switch fitting on side of feed tube for blockage Close Hopper Lid Check hopper switch operation Inspect and unjam the feed assembly Reconnect feed motor Plug the igniter in Center the igniter Igniter seated in chamber completely Replace igniter Clean firepot Clean below the firepot Put the firepot in the correct direction Clean firepot
Fire starts but goes out	Firepot is dirty Exhaust path and/or venting is plugged Exhaust sensor cannot read correct temperature Exhaust path is dirty Exhaust probe is not attached to outlet Exhaust probe is not plugged in to the board Exhaust probe is defective (error code may result)	Clean firepot. Check flue vent for obstruction Inspect and clean exhaust path and venting clean firebox including behind the baffles Inspect and clean the exhaust outlet especially the right side wall. Remove the right side panel and inspect to see if the exhaust probe is attached and tight against the exhaust outlet Plug the probe into the board Replace the exhaust probe
Unit starts and stops frequently when operating in the automatic mode	Area where the unit is installed heats and cools quickly depending on installation configuration. Tight spaces also may have an effect on the on/off cycling of the unit. Ambient probe Probe touching heated surface	Check the proximity to doors and windows and/or insulation factor of the structure. If heat loss is quick the unit may need to run on HI or LO. Inspect the probe and make sure it is not touching a surface that heats and cools quickly. The ambient probe has additional wire inside rear cavity which can be used to increase the distance from the unit.

Symptom	Possible Cause	Corrective Action
Slow or smoky start-up and/or lazy flame	Dirty exhaust and/or venting system. Not enough combustion air Misaligned igniter Wet fuel / poor quality fuel	Check for ash build up in unit, including behind rear panels, firebox, exhaust blower and venting. Adjust the trim Center the igniter in the chamber Replace fuel
Convection blower fails to start.	Convection Blower Jammed Not plugged in Exhaust probe Not sensing correct temperature Control box is defective.	Inspect, clean, and un-jam the blower. Plug the blower in Replace blower Clean the exhaust outlet especially the right side. Replace control box.
Exhaust blower fails to start	Exhaust Blower Jammed Not plugged in Control board is defective.	Inspect, clean, and un-jam the blower. Plug the blower in Replace blower Replace control board.
Convection Blower Does Not Turn Off	Convection blower short circuit. The fuse will be blown and upon replacement of the fuse, the blower will run continuously.	Inspect wires, blowers, and power cord to find cause of short circuit. Replace board and failed component.
Convection Blower makes noise	Screws attaching convection blower to appliance have become loose. Convection blower is dirty	Tighten screws Clean blower impellers per maintenance section
Exhaust Blower Does Not Turn Off	Exhaust blower short circuit. The fuse will be blown and upon replacement of the fuse, the blower will run continuously.	Inspect wires, blowers, and power cord to find cause of short circuit. Replace board and failed component.
Igniter does not turn off	Igniter short circuit. The fuse will be blown and upon replacement of the fuse, the igniter will remain on when unit has power.	Inspect wires, blowers, and power cord to find cause of short circuit. Replace board and failed component.
Feed motor does not shut off	Feed motor short circuit. The fuse will be blown and upon replacement of the fuse, the feed motor will remain on when unit has power.	Open hopper to stop the feed motor. Inspect wires feed motor, control board, and power cord to find source of short circuit. Replace control board and failed component.
Unit fails to shut off.	Unit running in maximum or minimum	Turn dial control to Automatic or Off position. See Also, "Feed Motor Does Not Shut Off". The unit should go into a shutdown.
Large, lazy flame, orange color. Black ash on glass.	Dirty appliance. Poor fuel quality, high ash content. Incorrect air-fuel adjustment Excessive feeding/Feed Motor locked on	Clean unit, including firepot and venting system. Clean exhaust path. Try a different brand of pellets. See trim pot adjustment section. Follow corrective action for feed motor does not turn off symptom.
Excessive fuel spilling over the firepot into the ash wells and/or excessive flame	Excessive feeding/Feed Motor locked on	Follow corrective action for feed motor does not turn off.
Black soot on the side of the house	Exhaust path is dirty. Excessive feeding/Feed Motor locked on Incorrect air-fuel ratio	Clean Exhaust path Follow corrective action for feed motor does not turn off symptom. Turn fuel adjustment trim dial to the LEFT to increase combustion air speed See "Trim Adjustment" section on Page 9.

Following correction of any Alarm, turn the dial control to the OFF position, wait 10 seconds and turn back to desired setting OR unplug the unit, wait 10 seconds then restore power.

Alarm (LED Flashing RED)	Possible Cause	Corrective Action
1 Flash: Empty Hopper	<p>No fuel is delivered to the firepot to sustain flame Hopper empty (most likely) Auger Jam (next likely) No vacuum Hopper lid open</p> <p>Flame is evident but the exhaust probe is not able to recognize the hot exhaust temperature Exhaust probe not attached to outlet Exhaust path is dirty</p>	<p>Fill the hopper, inspect the feed tube for jams, inspect the venting and firebox for obstructions and clean if necessary, inspect the exhaust blower to make sure it runs, or close the hopper lid.</p> <p>Inspect and clean the exhaust outlet, firebox, firepot, and behind the baffles. Inspect the exhaust probe to see if it is securely attached to the side of the exhaust outlet.</p>
2 Flashes: Exhaust Probe Fail <i>The exhaust probe senses a temperature of less than negative 20 degrees Celsius or above 300 degrees Celsius.</i>	<p>The exhaust temperature is above or below the acceptable range.</p> <p>Exhaust Probe Failure Not plugged in Failed component</p>	<p>Plug the probe into the board Replace the component</p>
3 Flashes: Ambient Probe Alarm <i>The ambient probe senses a temperature of less than negative 20 degrees Celsius or above 70 degrees Celsius.</i>	<p>The ambient temperature is above or below the acceptable range.</p> <p>Ambient Probe Failure Not plugged in Failed component</p>	<p>Plug the probe into the board Replace the component</p>
4 Flashes: Missed Ignition <i>During the ignition sequence the load does not ignite. The unit will automatically retry once from the first failed attempt.</i>	<p>Fuel No fuel Hopper Empty Feed Jam Feed doesn't turn Feed motor disconnected or failed</p> <p>Firepot Firepot Dirty so fuel is not near ignition hole in the firepot</p> <p>Igniter No power Debris in the end of the igniter chamber</p>	<p>Fill the hopper Inspect and clear jam in the feed tube Inspect the feed motor circuit (hopper lid must be closed, vacuum switch must be closed (ie exhaust blower on), and feed motor must be plugged in.</p> <p>Clean the firepot</p> <p>Check leads and if the igniter works.</p> <p>Clean the end of the igniter chamber from inside the firebox (removal of the firepot required for this step).</p>
8 Flashes: Exhaust Over Temperature <i>The exhaust temperature has exceeded the allowable temperature.</i>	<p>Fuel Feed Motor Locked On</p> <p>Non-approved fuel used</p> <p>Convection blower Dirty Failed</p> <p>Installation Installation configuration is tight allowing for limited air circulation around the unit.</p>	<p>Review the feed motor and feed rates. Normal feed motor operation is on between 1* and 4* seconds out of every 7 seconds. (*depending on model and burn rate setting) If the feed motor does not turn off, replace the control board. Review the fuel being used.</p> <p>Clean Replace</p> <p>Review the installation and move if necessary.</p>

13 Reference Materials

A. Component Function



When describing the location of a component, it is always AS YOU FACE THE FRONT OF THE APPLIANCE.

1. Control Board

The control board is located on the right side of the appliance behind the lower right side panel.

2. Convection Blower

The convection blower is mounted in the rear of the unit. It pushes air up the rear of the firebox, across the top and out the front. As the air moves past the firebox it is heated.

3. Exhaust Blower

The exhaust blower is mounted on the left side of the appliance. The exhaust blower is designed to pull the exhaust from the appliance and push it out through the venting system.

4. Feed System

The feed system can be accessed in two areas. To access the auger spring, remove the cover in the hopper. To remove the feed motor: Remove the right side panel and pull cotter pin that connects motor to auger shaft.

5. Firepot

The firepot is made of a combination of stainless steel and heavy duty cold rolled steel. It is removable to aid in cleaning.

6. Fuse

The fuse is located on the control board. The fuse will blow should a short occur and shut off power to the appliance.

7. Dial Control

The dial control is attached to the right side of the appliance. The large dial controls the heat output where as the small dial below the large dial is the trim feature. The LED blinks according to the state of the appliance.

8. Hopper Switch

The hopper switch is located in the upper right hand corner of the hopper. This switch is designed to shut down the feed motor whenever the hopper lid is opened.

9. Igniter

The igniter is mounted in the chamber in the rear of the firebox below the convection blower. Combustion air travels over the red hot igniter creating super heated air that ignites the pellets.

10. Power Supply

The power cord connector in the rear of the unit. Check the wall receptacle for 120 volt, 60 Hz (standard current). Make sure the outlet is grounded and has the correct polarity. A good surge protector is recommended.

11. Exhaust Probe

The exhaust probe is mounted to the side of the exhaust outlet in the rear of the unit. It senses the temperature of the exhaust and allows the control system to make decisions.

12. Ambient Probe

The ambient probe is located in the back panel. It has extra wire to increase distance from appliance if needed.

13. Snap Disc (Back Burn Protector) 200°F

Snap disc is mounted on the back of the auger tube in the center of the appliance and has a reset button. There are two grey wires connected to it. To access it remove the right side panel. If the fire tries to burn back into the feed system or push exhaust up the feed tube, this snap disc will shut the entire system off. Unplug the stove prior to resetting.

14. Vacuum Switch

The vacuum switch is located on the lower right side of the appliance behind right side panel. There are two red wires attached to it. This switch turns the feed system on when vacuum is present in the firebox. The vacuum switch is a safety device to shut off the feed motor if the exhaust or the heat exchanger system is dirty or plugged or if the firebox door is open or exhaust blower failure.

15. Outside air inlet

The outside air tube can be attached to the 2" OD inlet tube on the rear of the appliance.

B. Wiring Diagram

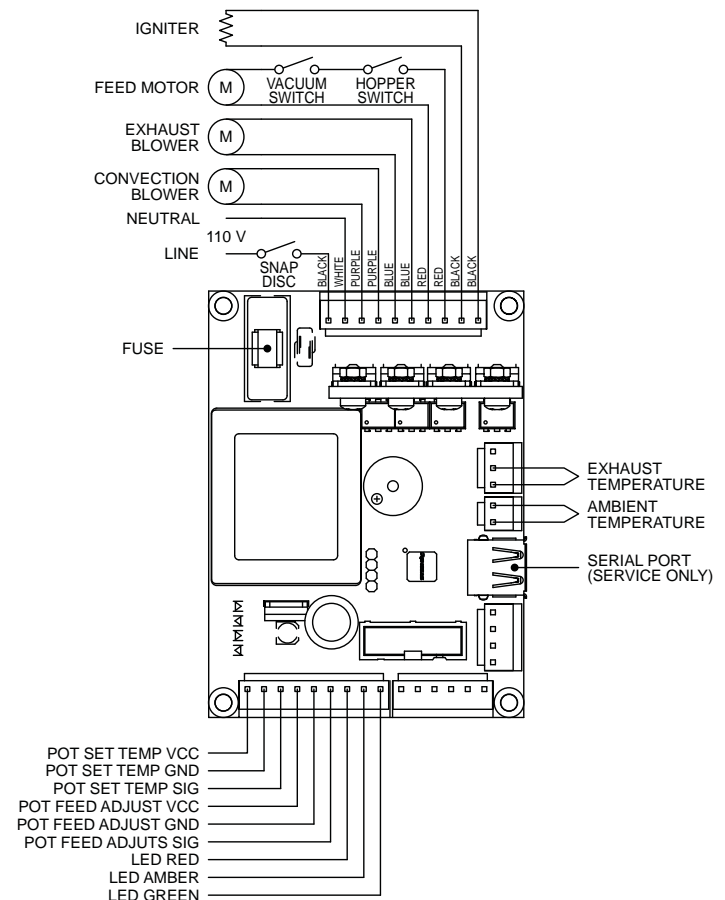

C. Replacement Parts



Service Parts

Pellet Stove

PP130

Beginning Manufacturing Date: Apr 2014
Ending Manufacturing Date: Active

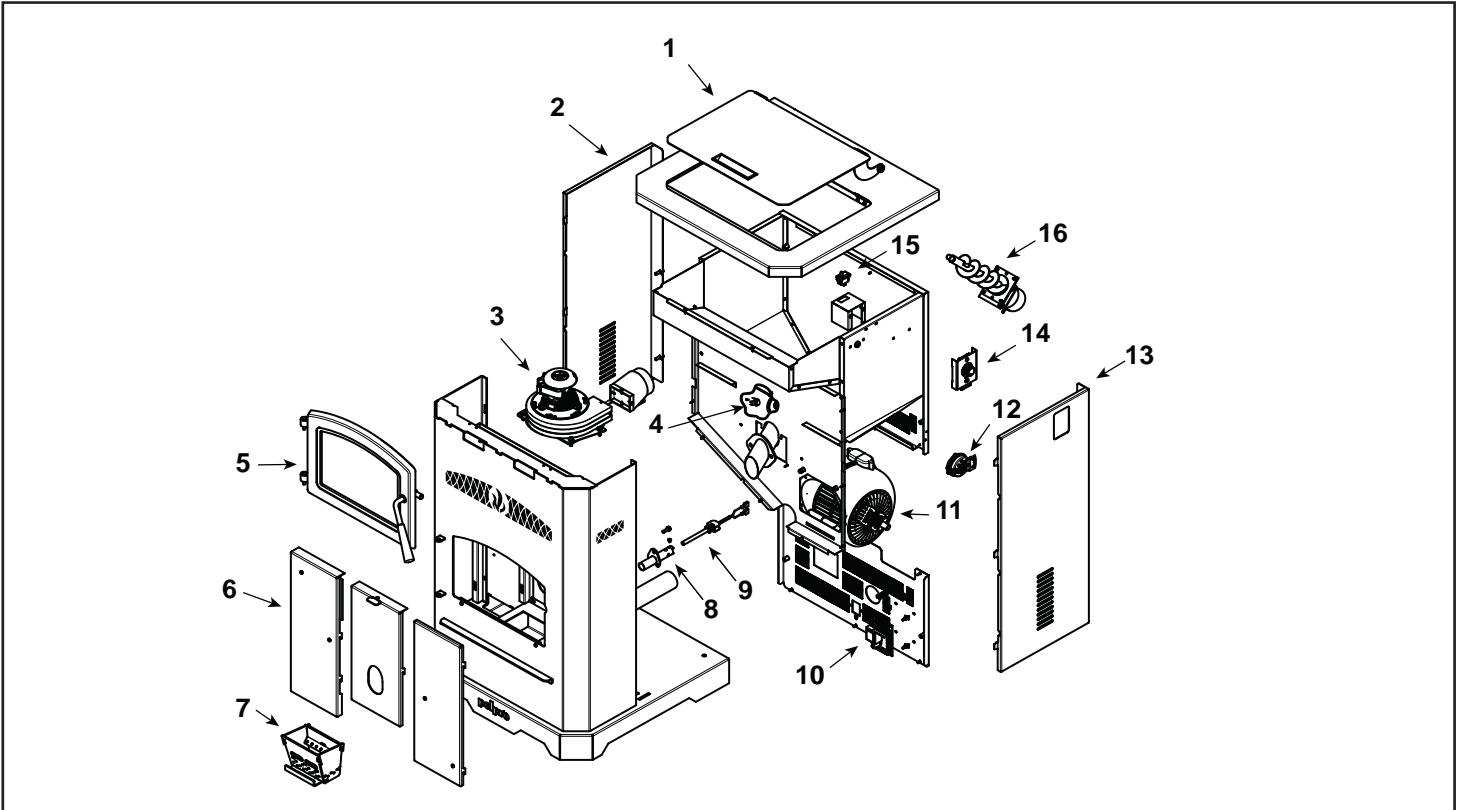

IMPORTANT: THIS IS DATED INFORMATION. When requesting service or replacement parts for your appliance please provide model number and serial number. All parts listed in this manual must be ordered from a dealer.



**Stocked
at Depot**

ITEM	DESCRIPTION	COMMENTS	PART NUMBER	
1	Hopper Lid Assembly		SRV7086-019	
2	Side Curtain, Left Hand		SRV7086-154	
3	Exhaust Combustion Blower		812-4400	Y
	Gasket, Between Blower Housing and Stove		240-0812	Y
4	Snap disc, Manual Reset		SRV230-0080	Y
5	Door Assembly		SRV7086-021	
6	Baffle Kit		SRV7079-006	
7	Firepot		SRV7077-003	Y
8	Igniter Chamber Kit		SRV7077-110	
9	Igniter Kit		SRV7000-660	Y
10	Control Board		SRV7077-050	Y
11	Convection Blower		KS-5020-1052	Y
12	Vacuum Switch		SRV7000-531	Y
	Vacuum Hose, 5/32 ID	3 Ft	SRV240-0450	Y
13	Side Curtain, Right Hand		SRV7086-153	Y
14	Dial Control Kit, w/Wire Harness		SRV7083-036	Y
15	Hopper Switch		SRV7000-612	Y

#5 Door Assembly

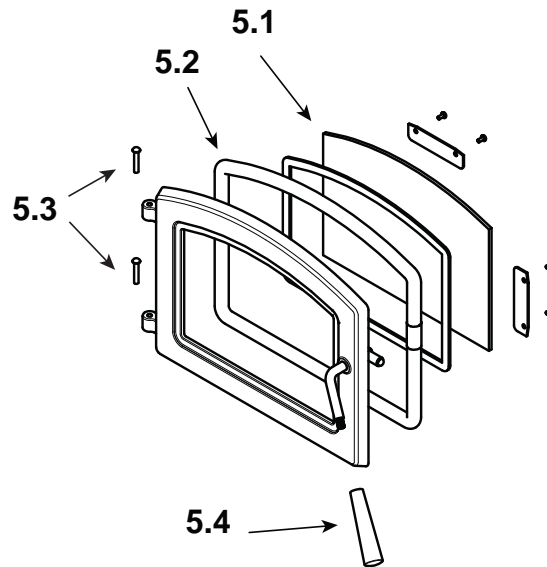

IMPORTANT: THIS IS DATED INFORMATION. When requesting service or replacement parts for your appliance please provide model number and serial number. All parts listed in this manual must be ordered from a dealer.



Stocked at Depot

ITEM	DESCRIPTION	COMMENTS	PART NUMBER
5	Door Assembly		SRV7086-021
5.1	Glass Assembly		SRV7081-173
5.2	Rope, Door, 3/4" x 84"		832-1680
5.3	Hinge Pins	Pkg of 2	433-1590/2
5.4	Handle, Black Phenolic Kit		KS-5140-1442

#16 Feed Assembly Kit

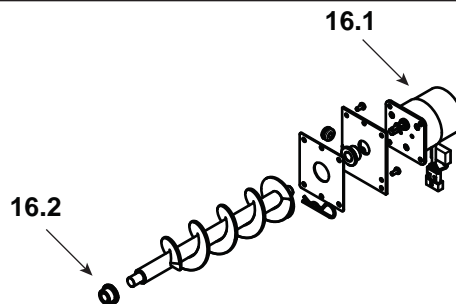

16	Feed Assembly Kit		SRV7077-014	
16.1	Feed Shaft Bushing	Pkg of 2	7000-600/2	
16.2	Feed Motor		SRV7000-670	Y
	Ambient Probe		SRV7000-668	Y
	Exhaust Probe		SRV7000-669	Y
	Wire Harness		SRV7077-184	Y
	Wire Clip	Pkg of 10	7000-400/10	Y

E. Warranty

Hearth & Home Technologies, Inc. PELPRO LIMITED WARRANTY

Hearth & Home Technologies Inc., on behalf of its hearth brands (“HHT”), extends the following warranty for PELPRO wood and pellet hearth appliances that are purchased from an HHT authorized dealer.

WARRANTY COVERAGE:

If an inspection by the dealer indicates that a limited warranty claim is justified, and all conditions of this limited warranty have been met, the manufacturer's total responsibilities and liabilities shall be to repair or replace, at the manufacturer's option, the defective part(s).

WARRANTY PERIOD:

All claims under this limited warranty must be made through the dealer where your stove was purchased. All costs of removal, shipment to and from the dealer or manufacturer, any losses during shipment and reinstallation, and any other losses due to your stove being removed, shall be covered by the owner of the stove. The warranty period for parts and labor for covered components is produced in the following table.

Warranty Period		PelPro Appliances	Components Covered
Parts	Labor	Pellet	
1 Year	No Coverage	X	Electrical
5 Years	No Coverage	X	Steel Parts (excluding burn grate)
90 Days	No Coverage	X	All replacement parts beyond warranty period

WARRANTY EXCLUSIONS:

The warranty does not cover damage or breakage due to misuse, improper handling or modifications. There specifically is no warranty on the paint, glass, burn grate, fire brick and all gaskets or against damage caused from corrosion. **There is no written or implied performance warranty on PelPro SERIES stoves as the manufacturer has no control over the installation, operations, cleaning, maintenance or the type of fuel burned.**

This Warranty is Void If:

- Stove has not been installed, operated, cleaned and maintained in strict accordance with the manufacturer's instructions.
- Burning other than quality wood pellets may void the warranty.

WARRANTY EXCLUSIONS:

Some states do not allow the exclusion or limitation of incidental or consequential damages, or limitations of implied warranties, so the limitations or exclusions set forth in this limited warranty may not apply to you. This limited warranty gives you specific legal rights and you may have other rights, which vary from state to state.

NEITHER THE MANUFACTURER, NOR THE SUPPLIERS TO THE PURCHASER, ACCEPTS RESPONSIBILITY, LEGAL OR OTHERWISE, FOR THE INCIDENTAL OR CONSEQUENTIAL DAMAGE TO THE PROPERTY OR PERSONS RESULTING FROM THE USE OF THIS PRODUCT. ANY WARRANTY IMPLIED BY LAW, INCLUDING BUT NOT LIMITED TO IMPLIED WARRANTIES OF MERCHANTABILITY OR FITNESS, SHALL BE LIMITED TO ONE (1) YEAR FROM THE DATE OF ORIGINAL PURCHASE. WHETHER A CLAIM IS MADE AGAINST THE MANUFACTURER BASED ON THE BREACH OF THIS WARRANTY OR ANY OTHER TYPE OF WARRANTY EXPRESSED OR IMPLIED BY LAW, MANUFACTURER SHALL IN NO EVENT BE LIABLE FOR ANY SPECIAL, INDIRECT, CONSEQUENTIAL OR OTHER DAMAGES OF ANY NATURE WHATSOEVER IN EXCESS OF THE ORIGINAL PURCHASE PRICE OF THIS PRODUCT. ALL WARRANTIES BY MANUFACTURER ARE SET FORTH HEREIN AND NO CLAIM SHALL BE MADE AGAINST MANUFACTURER ON ANY ORAL WARRANTY OR REPRESENTATION.

Your purchase must be registered with **HEARTH & HOME TECHNOLOGIES**. This can be done online at www.pelprostoves.com.

PARTS, SERVICE, AND RETURNS:

It is Hearth & Home Technologies policy, that NO pellet appliance be returned to any dealer without prior authorization from Hearth & Home Technologies Consumer Care Department. We strongly suggest that if you do need to order any parts or options or require service, that you first deal with your local dealer. Many dealers do stock parts and options. The majority of the parts names can be found within this manual.



CONTACT INFORMATION:

1445 North Highway
Colville, WA 99114

**Please contact the Hearth & Home Technical Group with
any questions or concerns.
www.pelprostoves.com**

**We recommend that you record the following pertinent
information for your heating appliance.**

Date purchased/installed: _____

Serial Number: _____ Location on appliance: _____

Store purchased from: _____ Store Location: _____

Notes: _____

Hearth & Home Technologies
1445 North Highway
Colville, WA 99114
Division of HNI INDUSTRIES