

This appliance has been retired.
For replacement parts, please refer to the individual
service parts list located on the brand websites.

Installation Manual

Installation and Appliance Setup

INSTALLER: Leave this manual with party responsible for use and operation.

OWNER: Retain this manual for future reference.

Contact your dealer with questions regarding installation, operation or service.

NOTICE: DO NOT discard this manual!

HEAT & GLO

No one builds a better fire

Models:

6X-AU



Ref No GMK10489
AS/NZS 5263.1.3

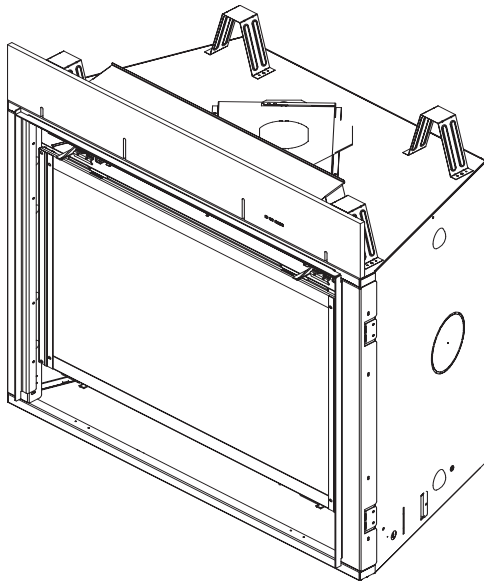

**NOTE: NOT INTENDED FOR
FIREPLACE INSERT.**

⚠ WARNING:
FIRE OR EXPLOSION HAZARD
Failure to follow safety warnings exactly
could result in serious injury, death, or
property damage.

- **DO NOT** store or use gasoline or other flammable vapors and liquids in the vicinity of this or any other appliance.
- **What to do if you smell gas**
 - **DO NOT** try to light any appliance.
 - **DO NOT** touch any electrical switch. **DO NOT** use any phone in your building.
 - Leave the building immediately.
 - Immediately call your gas supplier from a neighbor's phone. Follow the gas supplier's instructions.
 - If you cannot reach your gas supplier, call the fire department.
- Installation and service must be performed by a qualified installer, service agency, or the gas supplier.

! DANGER



**HOT GLASS WILL
CAUSE BURNS.**

**DO NOT TOUCH GLASS
UNTIL COOLED.**

**NEVER ALLOW CHILDREN
TO TOUCH GLASS.**

A barrier designed to reduce the risk of burns from the hot viewing glass is provided with this appliance and shall be installed for the protection of children and other at-risk individuals.

DO NOT PLACE ARTICLES ON OR AGAINST THIS APPLIANCE.

DO NOT USE OR STORE FLAMMABLE MATERIALS NEAR THIS APPLIANCE.

DO NOT SPRAY AEROSOLS IN THE VICINITY OF THIS APPLIANCE WHILE IT IS IN OPERATION.

DO NOT MODIFY THIS APPLIANCE.

▲ Safety Alert Key:

- **DANGER!** Indicates a hazardous situation which, if not avoided will result in death or serious injury.
- **WARNING!** Indicates a hazardous situation which, if not avoided could result in death or serious injury.
- **CAUTION!** Indicates a hazardous situation which, if not avoided, could result in minor or moderate injury.
- **NOTICE:** Used to address practices not related to personal injury.

Table of Contents

Installation Standard Work Checklist	3	7 Venting and Chimneys	
1 Product Specific and Important Safety Information		A. Assemble Vent Sections	36
A. Appliance Certification	4	B. Secure the Vent Sections	37
B. Glass Specifications	4	C. Disassemble Vent Sections	37
C. Gas Pressure Requirements	4	D. Vertical Termination Requirements	38
D. High Altitude Installations	5	E. Horizontal Termination Requirements	39
E. Non-Combustible Materials Specification	5	8 Electrical Information	
F. Combustible Materials Specification	5	A. General Information	42
G. Electrical Codes	5	B. Wiring Requirements	43
2 Getting Started		9 Gas Information	
A. Design and Installation Considerations	6	A. Fuel Conversion	44
B. Good Faith Wall Surface/TV Guidelines	6	B. Gas Pressure	44
C. Tools and Supplies Needed	6	C. Gas Service Access	44
D. Inspect Appliance and Components	7	D. Gas Connection	44
3 Framing and Clearances		E. High Altitude Installations	44
A. Appliance/Decorative Front Dimension Diagrams	8	F. Air Shutter Setting	45
B. Clearances to Combustibles	10	10 Finishing	
C. Constructing the Appliance Chase	12	A. Facing Material	46
→ D. Floor Protection	12	B. Mantel and Wall Projections	47
4 Termination Location and Vent Information		C. Decorative Fronts	48
A. Vent Termination Minimum Clearances	13	11 Appliance Setup	
B. Chimney Diagram	14	A. Remove Fixed Glass Assembly	50
C. Approved Pipe	15	B. Remove the Shipping Materials	50
D. Use of Elbows	15	C. Clean the Appliance	50
E. Measuring Standards	16	D. Burner Top Installation	50
F. Vent Diagrams	17	E. Install the Glass Refractory	51
G. Power Vent Configurations	29	F. Ember Placement	52
5 Vent Clearances and Framing		G. Install the Teco-Sil	53
A. Pipe Clearances to Combustibles	30	H. Install the Log Assembly	54
B. Wall Penetration Framing/Firestops	30	I. Install Fixed Glass Assembly	57
C. Ceiling Firestop/Floor Penetration Framing	31	J. Install Decorative Front	57
D. Install Attic Insulation Shield	31	12 Reference Materials	
6 Appliance Preparation		A. Vent Components Diagrams	58
A. Vent Collar Preparation	32	B. Accessories	63
B. Installing Optional Heat-Zone®-240V	34		
C. Securing and Leveling the Appliance	35		
D. Installing the Non-combustible Board	35		

→ = Contains updated information.

Installation Standard Work Checklist

ATTENTION INSTALLER: Follow this Standard Work Checklist

This standard work checklist is to be used by the installer in conjunction with, not instead of, the instructions contained in this installation manual.

Customer: _____
Lot/Address: _____

Date Installed: _____
Location of Fireplace: _____

Model (circle one): 6X-AU _____

Installer: _____
Dealer/Distributor Phone # _____
Serial #: _____

 **WARNING! Risk of Fire or Explosion!** Failure to install appliance according to these instructions could lead to a fire or explosion.

<u>Appliance Install</u>	YES	IF NO, WHY?
Verified that the chase is insulated and sealed. (Pg. 12)	<input type="checkbox"/>	_____
Required non-combustible board is installed. (Pg. 34)	<input type="checkbox"/>	_____
Verified clearances to combustibles. (Pg. 10-11)	<input type="checkbox"/>	_____
Fireplace is plum, level, square and secured. (Pg. 34)	<input type="checkbox"/>	_____
 <u>Venting/Chimney Section 7 (Pg 35-40)</u>		
Venting configuration complies to vent diagrams.	<input type="checkbox"/>	_____
Venting installed, locked and secured in place with proper clearance.	<input type="checkbox"/>	_____
Firestops installed.	<input type="checkbox"/>	_____
Attic insulation shield installed.	<input type="checkbox"/>	_____
Exterior wall/Roof flashing installed and sealed.	<input type="checkbox"/>	_____
Terminations installed and sealed.	<input type="checkbox"/>	_____
 <u>Electrical Section 8 (Pg 41-42)</u>		
Unswitched power (220-240 VAC) provided to the appliance.	<input type="checkbox"/>	_____
Switch wires properly installed.	<input type="checkbox"/>	_____
 <u>Gas Section 9 (Pg 43-44)</u>		
Proper appliance for fuel type.	<input type="checkbox"/>	_____
Was a conversion performed?	<input type="checkbox"/>	_____
Leak check performed and inlet pressure verified.	<input type="checkbox"/>	_____
Verified proper air shutter setting for installation type.	<input type="checkbox"/>	_____
 <u>Finishing Section 10 (Pg 45-48)</u>		
Combustible materials not installed in non-combustible areas.	<input type="checkbox"/>	_____
Verified all clearances meet installation manual requirements.	<input type="checkbox"/>	_____
Mantels and wall projections comply with installation manual requirements.	<input type="checkbox"/>	_____
 <u>Appliance Setup Section 11 (Pg 49-56)</u>		
All packaging and protective materials removed (inside & outside of appliance).	<input type="checkbox"/>	_____
Refractories, logs, media and embers installed correctly.	<input type="checkbox"/>	_____
Glass assembly installed and secured.	<input type="checkbox"/>	_____
Accessories installed properly.	<input type="checkbox"/>	_____
Mesh, doors, or decorative front properly installed.	<input type="checkbox"/>	_____
Manual bag and all of its contents are removed from inside/under the appliance and given to party responsible for use and operation.	<input type="checkbox"/>	_____
Started appliance and verified no gas leaks exist.	<input type="checkbox"/>	_____

Hearth & Home Technologies recommends the following:

- Photographing the installation and copying this checklist for your file.
- That this checklist remain visible at all times on the appliance until the installation is complete.

Comments: Further description of the issues, who is responsible (Installer/ Builder/ Other Trades, etc) and corrective action needed _____

Comments Communicated to party responsible _____ by _____ on _____
 (Builder / Gen. Contractor/) (Installer) (Date)

➔ = Contains updated information.

2508-982B 3/18

1 Product Specific and Important Safety Information

A. Appliance Certification

MODELS: 6X-AU

LABORATORY: IAPMO OCEANA

TYPE: Gas Space Heating Appliance

STANDARD: AS/NZS 5263.1.3

This product is tested and approved as a gas space heating appliance.

This appliance must be installed in accordance with the AS/NZS 5601.1 rules in force.

NOT INTENDED FOR USE AS A PRIMARY HEAT SOURCE.
This appliance is tested and approved as either supplemental room heat or as a decorative appliance. It should not be factored as primary heat in residential heating calculations.

B. Glass Specifications

This appliance is equipped with 5 mm ceramic glass with an anti-reflective coating. Replace glass only with glass with identical specifications. Please contact your dealer for replacement glass.

C. Gas Pressure Requirements

Pressure requirements for 6X-AU fireplaces are shown in table below.

Two taps are provided on the gas control for a test gauge connection to measure the inlet and outlet pressures.

The fireplace and its individual shut-off valve must be disconnected from the gas supply piping system during any pressure testing of the system at test pressures in excess of 3.4 kPa.

If the fireplace must be isolated from the gas supply piping system by closing an individual shut-off valve, it must be of the handle-less type.

NOTE: An inline fuel pressure regulator is recommended to limit NG inlet pressure to 2.49 kPa, and LP/ULPG inlet pressure to 3.25 kPa, to ensure optimum product performance. The inline fuel pressure regulator may be needed if any of the following symptoms exist: pilot jetting, a highly visible pilot flame, flame variation, etc. The inline pressure regulator should be installed in the gas line upstream of the appliance gas valve either at the appliance or in the utility room. Final main and manifold gas pressure must be tested with inline pressure regulator installed.

	Natural Gas	Propane	ULPG
Inlet Gas Pressure	1.13 - 3.40 kPa	2.75 - 3.40 kPa	2.75 - 3.40 kPa
* Outlet (Manifold) Gas Pressure	.87 kPa	2.49 kPa	2.49 kPa
Gas Rate	.405 m ³ /h	.134 m ³ /h	.111 m ³ /h
Maximum Gas Consumption	40.60 MJ/h	40.10 MJ/h	30.60 MJ/h
Burner Injector	0.124 DMS (3.150 mm)	#49 DMS (1.854 mm)	#53 DMS (1.511 mm)
Pilot Injector	Ø .023 (.584 mm)	Ø .014 (.356 mm)	Ø .010 (.254 mm)

Gas types only through field conversions.

* The allowable Outlet (Manifold) Gas Pressure ranges are: Natural Gas .80 - .95 kPa (.87 kPa nominal) and Propane, ULPG 2.37 - 2.61 kPa (2.40 kPa nominal). Certification testing setpoint values are shown.

D. High Altitude Installations

NOTICE: *If the heating value of the gas has been reduced, these rules do not apply. Check with your local gas utility or authorities having jurisdiction.*

When installing above 2000 ft. (610 m) elevation:

Reduce input rate 4% for each 1000 ft. (305 m) above 2000 ft. (610 m).

E. Non-Combustible Materials Specification

Material which will not ignite and burn. Such materials are those consisting entirely of steel, iron, brick, tile, concrete, slate, glass or plasters, or any combination thereof.

Materials that are reported as passing **ASTM E 136, Standard Test Method for Behavior of Materials in a Vertical Tube Furnace at 750 °C (1382 °F)** shall be considered non-combustible materials.

F. Combustible Materials Specification

Materials made of or surfaced with wood, compressed paper, plant fibers, plastics, or other material that can ignite and burn, whether flame proofed or not, or plastered or unplastered shall be considered combustible materials.

G. Electrical Codes

All electrical safety testing has been done following the EN 60335-2-102 standard. Local codes apply.

2 Getting Started

A. Design and Installation Considerations

Heat & Glo direct vent gas appliances are designed to operate with all combustion air siphoned from outside of the building and all exhaust gases expelled to the outside. No additional outside air source is required.

Installation **MUST** comply with local, regional, state and national codes and regulations. Consult insurance carrier, local building inspector, fire officials or authorities having jurisdiction over restrictions, installation inspection and permits.

Before installing, determine the following:

- Where the appliance is to be installed.
- The vent system configuration to be used.
- Gas supply piping requirements.
- Provisions for optional Heat-Zone®-240V(s)
- Electrical wiring requirements.
- Framing and finishing details.
- Whether optional accessories - devices such as a wall switch, or remote control - are desired.

Installation and service of this appliance should be performed by qualified personnel. Hearth & Home Technologies recommends HHT Factory Trained or certified professionals.



Improper installation, adjustment, alteration, service or maintenance can cause injury or property damage. For assistance or additional information, consult a qualified service technician, service agency or your dealer.

B. Good Faith Wall Surface/TV Guidelines

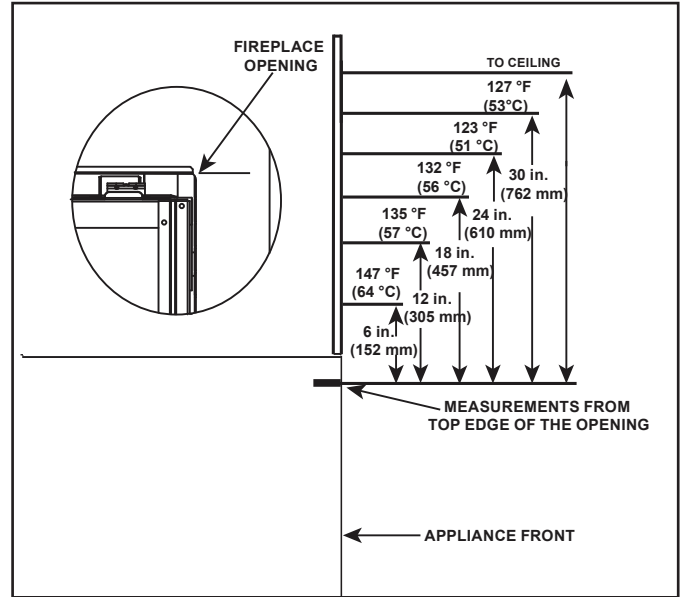

Figure 2.1 Good Faith Wall Surface Temperatures Above Appliance

NOTICE: Temperatures listed above are taken with a temperature measuring probe as prescribed by the test standard used for appliance certification. Temperatures on walls or mantels taken with an infrared thermometer may yield increased temperatures of up to 30 °F (17 °C) or more depending on the thermometer settings and material characteristics being measured.

C. Tools and Supplies Needed

Before beginning the installation be sure that the following tools and building supplies are available.

- | | |
|--|---|
| Tape measure | Framing material |
| Pliers | Hammer |
| Phillips screwdriver | Manometer |
| Gloves | Framing square |
| Voltmeter | Electric drill and bits -1/4 in. (6 mm) |
| Plumb line | Safety glasses |
| Level | Reciprocating saw |
| Flat blade screwdriver | |
| Non-corrosive leak check solution | |
| 1/2 - 3/4 in. (13 - 19 mm) length, #6 or #8 Self-drilling screws | |
| Caulking material (300 °F (149 °C) minimum continuous exposure rating) | |
| One 1/4 in. (6 mm) female connection (for optional fan) | |

D. Inspect Appliance and Components

- Carefully remove the appliance and components from the packaging.
- The vent system components and decorative doors and fronts may be shipped in separate packages.
- If packaged separately, the log set and appliance grate must be installed.
- Report to your dealer any parts damaged in shipment, particularly the condition of the glass.
- **Read all of the instructions before starting the installation. Follow these instructions carefully during the installation to ensure maximum safety and benefit.**

WARNING! Risk of Fire or Explosion! Damaged parts could impair safe operation. **DO NOT** install damaged, incomplete or substitute components. Keep appliance dry.

Hearth & Home Technologies disclaims any responsibility for, and the warranty will be voided by, the following actions:

- Installation and use of any damaged appliance or vent system component.
- Modification of the appliance or vent system.
- Installation other than as instructed by Hearth & Home Technologies.
- Improper positioning of the gas logs or the glass door.
- Installation and/or use of any component part not approved by Hearth & Home Technologies.

Any such action may cause a fire hazard.

WARNING! Risk of Fire, Explosion or Electric Shock! **DO NOT** use this appliance if any part has been under water. Call a qualified service technician to inspect the appliance and to replace any part of the control system and/or gas control which has been under water.

3 Framing and Clearances

A. Appliance/Decorative Front Dimension Diagrams

Dimensions are actual appliance dimensions. Use for reference only. For framing dimensions and clearances refer to Section 5.

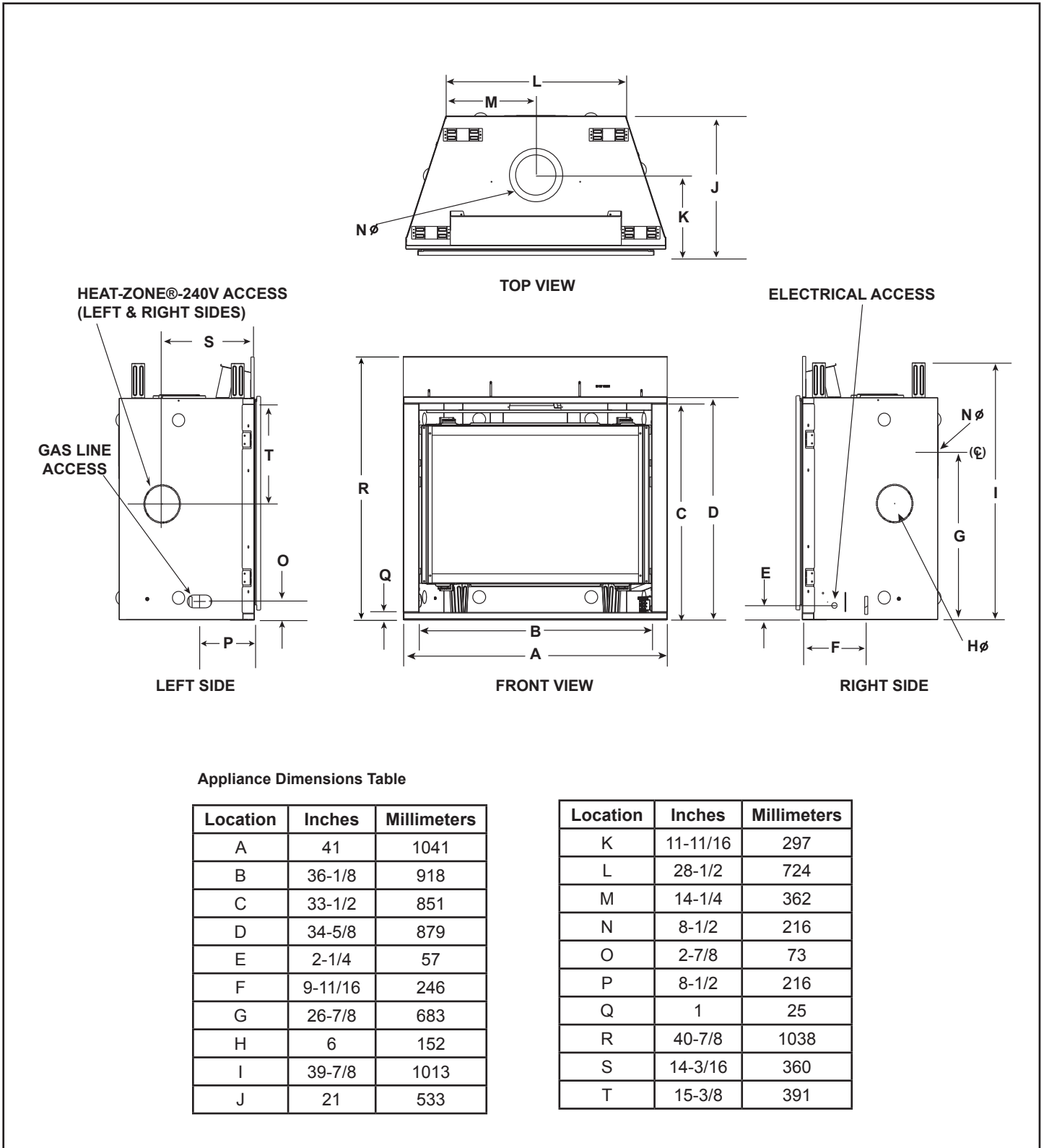
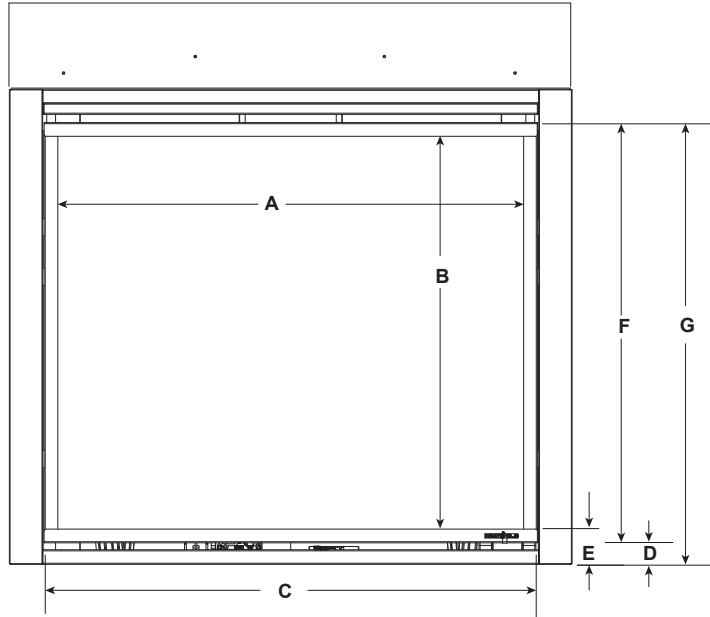

Figure 3.1 Appliance Dimensions

FIRESCREEN DECORATIVE FRONT



			A	B	C	D	E	F	G
6X-AU	FS-7	in.	34	28-3/4	35-15/16	1-5/8	2-5/8	30-5/8	32-1/4
		mm	864	730	913	41	67	778	819

CLEAN FACE DECORATIVE FRONT

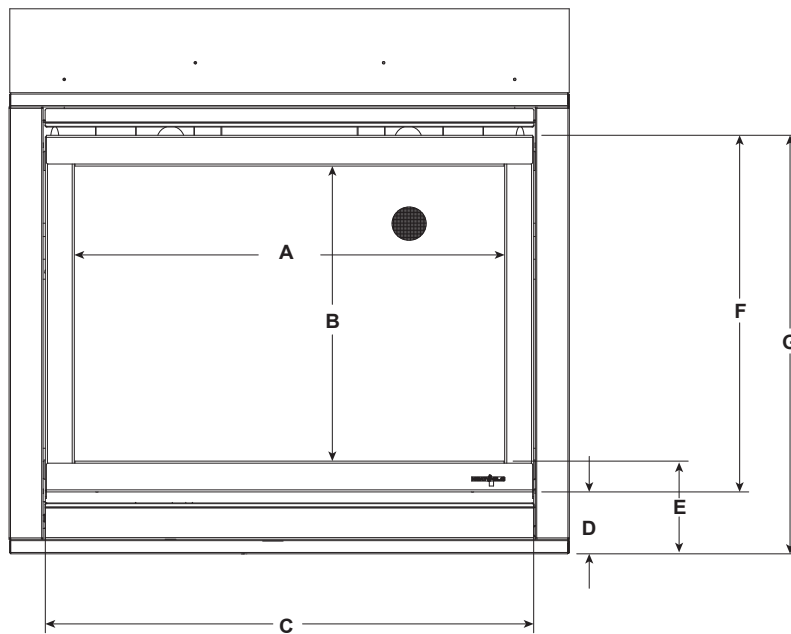

			A	B	C	D	E	F	G
6X-AU	CF-36	in.	31-9/16	22-1/8	35-13/16	4-5/8	6-15/16	26-3/4	31-7/16
		mm	802	562	910	117	176	679	799

Figure 3.2 Decorative Front Dimensions - Firescreen and Clean Face

B. Clearances to Combustibles

When selecting a location for the appliance it is important to consider the required clearances to walls (see Figure 3.3).

WARNING! Risk of Fire or Burns! Provide adequate clearance around air openings and for service access. Due to high temperatures, the appliance should be located out of traffic and away from furniture and draperies.

NOTICE: Illustrations reflect typical installations and are FOR DESIGN PURPOSES ONLY. Illustrations/diagrams are not drawn to scale. Actual installation may vary due to individual design preference.

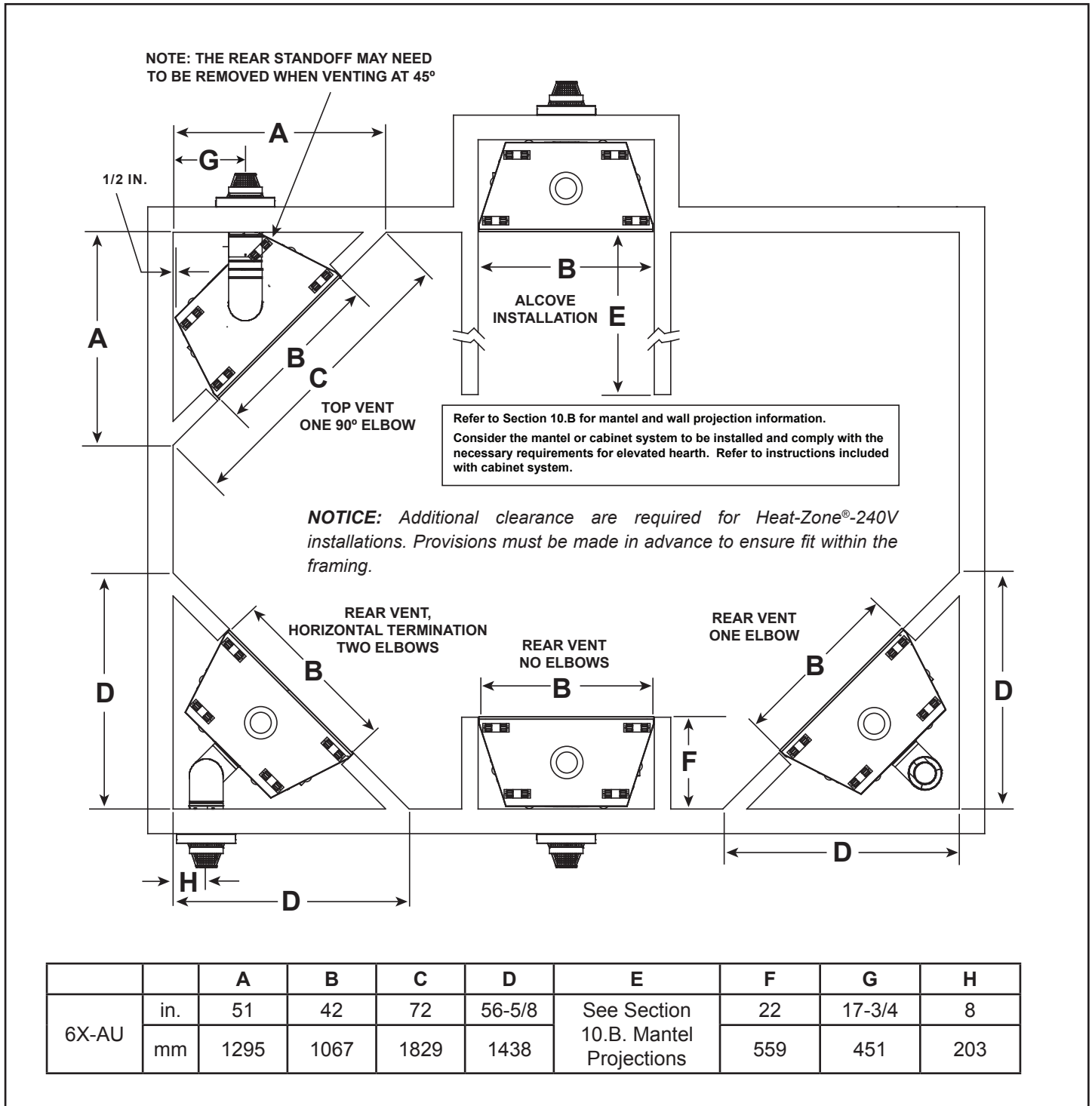
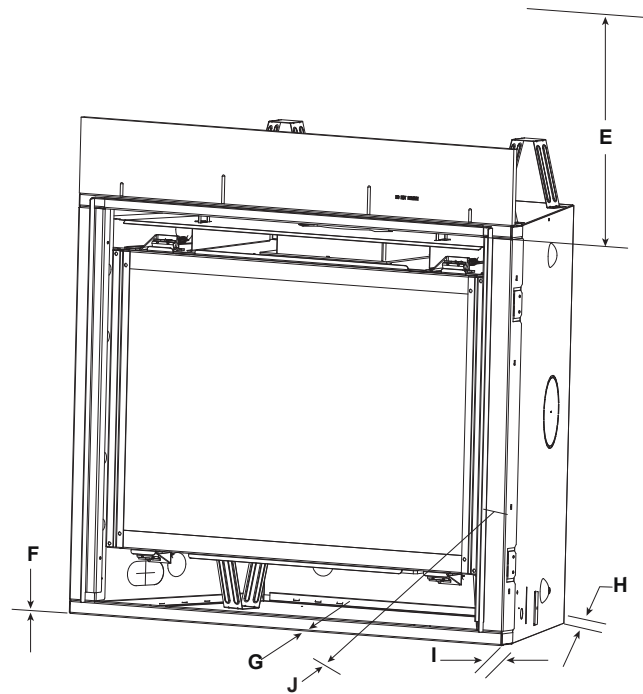
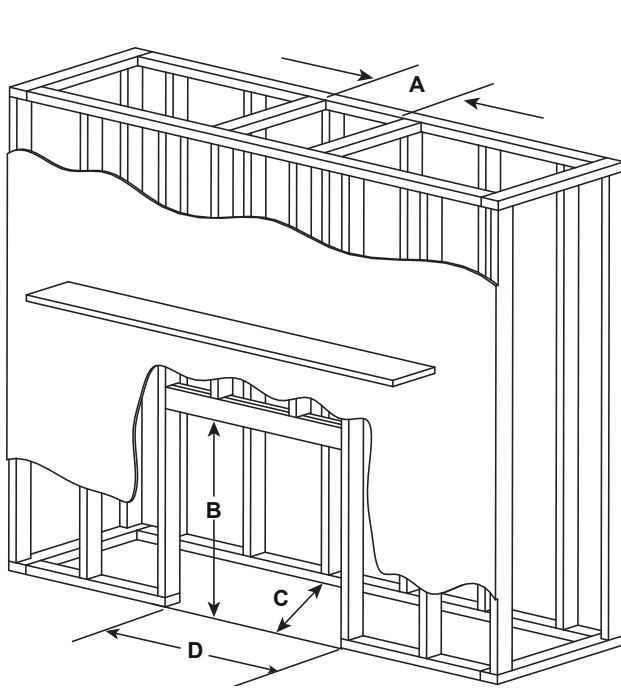
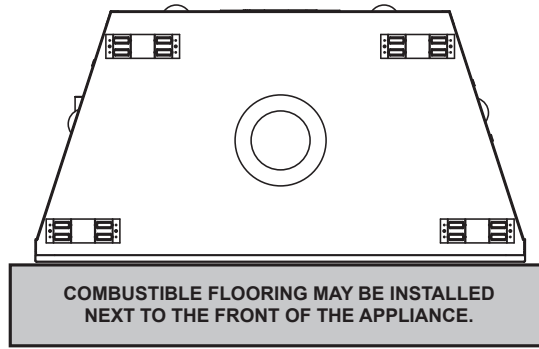

Figure 3.3 Appliance Locations



* MINIMUM FRAMING DIMENSIONS											
Models		A	B	C**	D	E	F	G***	H	I	J
		Rough Opening (Width)	Rough Opening (Height)	Rough Opening (Depth)	Rough Opening (Width)	Clearance to Ceiling (Measured from top of appliance opening)	Combustible Floor	Combustible Flooring	Behind Appliance	Sides of Appliance	Front of Appliance
6X-AU	in.	10	40-1/8	22	42	32	0	0	1/2	1/2	36
	mm	254	1019	559	1067	813	0	0	13	13	914

* Adjust framing dimensions for interior sheathing (such as sheetrock)

C** Add 12 in (305 mm) for rear venting with one 90° elbow.

*** For installations with vinyl flooring, see Section 3.D.

Figure 3.4 Minimum Framing Dimension

C. Constructing the Appliance Chase

A chase is a vertical box-like structure built to enclose the gas appliance and/or its vent system. In cooler climates the vent should be enclosed inside the chase.

NOTICE: Treatment of ceiling firestops and wall shield firestops and construction of the chase may vary with the type of building. These instructions are not substitutes for the requirements of local building codes. Therefore, you **MUST** check local building codes to determine the requirements to these steps.

Chases should be constructed and insulated in the same manner as the thermal envelope of the home based on the code requirements for that climate zone to prevent air leakage and draft problems. The chase is an extension of the building thermal envelope.

To further prevent drafts and air leakage, the wall shield and ceiling firestops should be caulked with caulk with a minimum of 300 °F (149 °C) continuous exposure rating to seal gaps. Gas line holes and other openings should be caulked with caulk with a minimum of 300 °F (149 °C) continuous exposure rating or stuffed with unfaced insulation. If the appliance is being installed on a cement surface, a layer of plywood may be placed underneath to prevent conducting cold up into the room.

NOTICE: Install appliance on hard metal or wood surfaces extending full width and depth. **DO NOT** install directly on carpeting, vinyl, tile or any combustible material other than wood.

WARNING! Risk of Fire! Maintain specified air space clearances to appliance and vent pipe:

- Insulation and other materials must be secured to prevent accidental contact.
- The chase must be properly blocked to prevent blown insulation or other combustibles from entering and making contact with fireplace or chimney.
- Failure to maintain airspace may cause overheating and a fire.

D. Floor Protection

Vinyl Flooring

Vinyl flooring is sensitive to heat. To avoid damage to the vinyl flooring, a 12 in (309 mm) minimum x 12 in (305 mm) minimum hearth is recommended when using vinyl flooring up to the wall. See Figure 3.5. If no hearth is used, it is recommended to provide a minimum of 30 in (762 mm) inches of clearance in front of the appliance to the vinyl flooring OR the bottom of the appliance should be raised a minimum of 24 in (610 mm) off of the floor to allow the vinyl flooring to be installed up to the wall.

NOTICE: Clearances that do not meet the minimum guidelines could result in damage or buckling to the vinyl flooring and is done at the installer's risk.

Hearth and Home Technologies does not recommend adhesive based vinyl flooring products due to thermal expansion during operation. Floating style flooring can be used, but will reach temperatures up to to 110 °F (43 °C) (based on ambient temperature of 70 °F (21 °C)). Consult the manufacturer's flooring specifications to ensure compatibility.

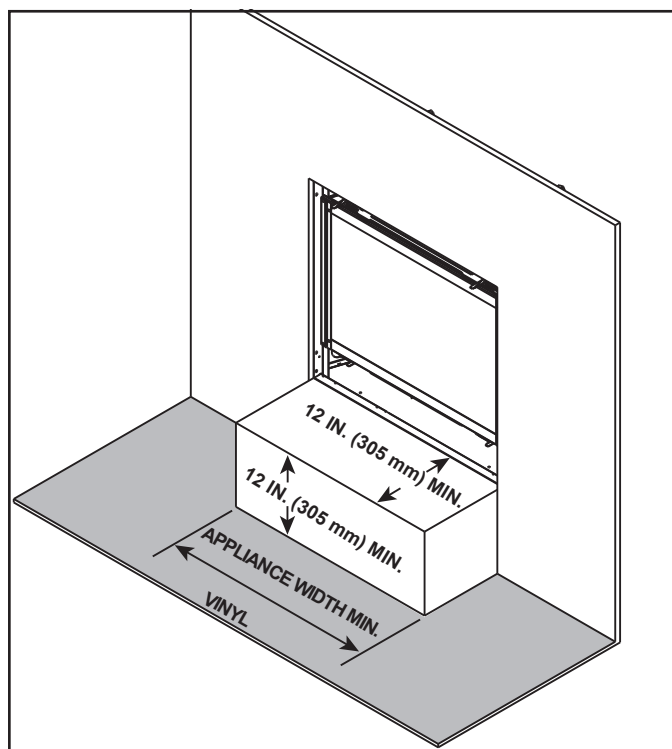

Figure 3.5 Vinyl Flooring Recommendations

4 Termination Location and Vent Information

A. Vent Termination Minimum Clearances

WARNING

Fire Risk.
Maintain vent clearance to combustibles as specified.

- **DO NOT** pack air space with insulation or other materials.

Failure to keep insulation or other materials away from vent pipe could cause overheating and fire.

Angle	H (Min.) mm
0°-26.6°	500*
26.6°-30.3°	500*
30.3°-33.7°	500*
33.7°-36.9°	610*
36.9°-39.8°	760*
39.8°-42.5°	990
42.5°-45.0°	1220
45.0°-49.4°	1520
49.4°-53.1°	1830
53.1°-56.3°	2130
56.3°-59.0°	2290
59.0°-60.3°	2440

*H minimum may vary depending on regional snowfall. Refer to local codes.

A	B
6 in. (minimum) up to 20 in. <i>152 mm/508 mm</i>	18 in. minimum <i>457 mm</i>
20 in. and over	0 in. minimum

* If using decorative cap cover(s), this distance may need to be increased. Refer to the installation instructions supplied with the decorative cap cover.

** In a staggered installation with both gas and wood or fuel oil terminations, the wood or fuel oil termination cap must be higher than the gas termination cap.

Figure 4.2 Staggered Termination Caps

Figure 4.1 Minimum Height From Roof To Lowest Discharge Opening

B. Chimney Diagram

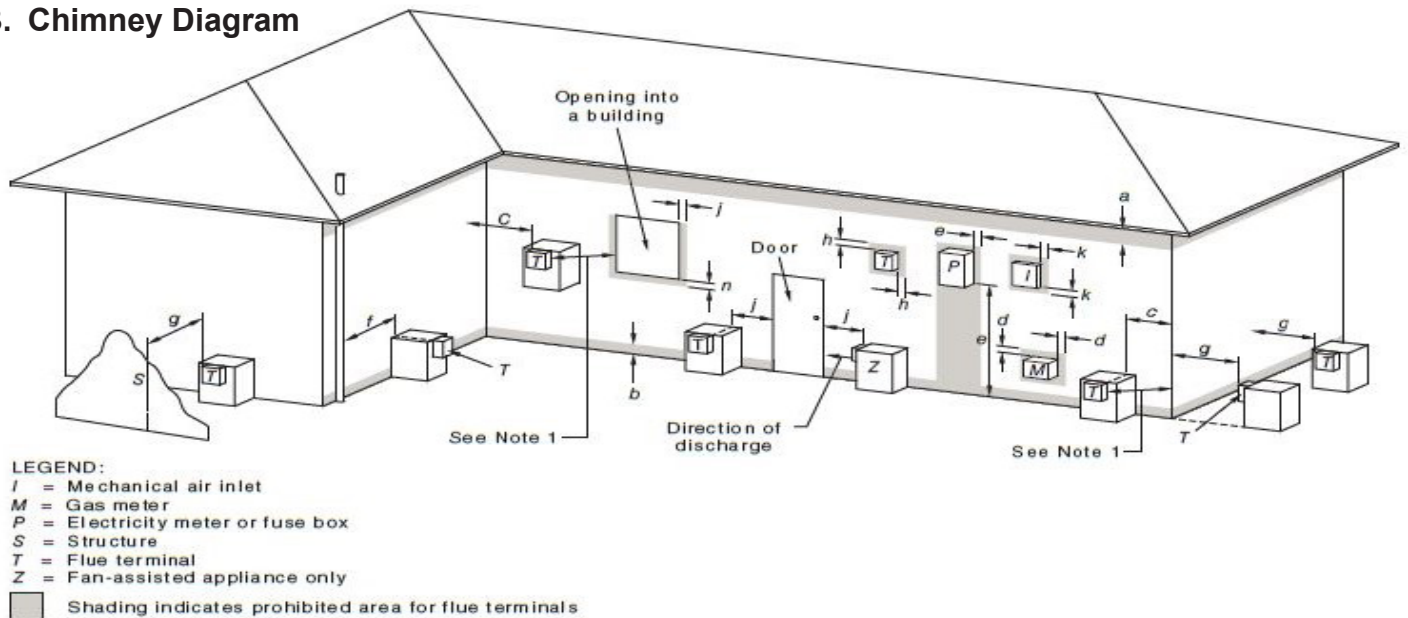

Ref.	Item	Minimum Clearance (mm)	
		Natural Draft	Fan Assisted
a	Below eaves, balconies or other projections		
	Appliances up to 50 MJ/h input	300	200
	Appliances over to 50 MJ/h input	500	300
b	From the ground or above a balcony		
	Appliances 32 MJ/h and below	300	355
	Appliances from 32 MJ/h to 53 MJ/h	300	410
	Appliances 53 MJ/h and above	300	460
c	From a return wall or external corner	500	300
d	From a gas meter (M)	1000	1000
e	From an electricity meter or fuse box (P)	500	500
f	From a drain or soil pipe	150	75
g	Horizontally from any building structure (unless appliance approved for closer installation) or obstruction facing a terminal	500	500
h	From any other flue terminal, cowl, or combustion air intake	500	300
j	Horizontally from an openable window, door, non-mechanical air inlet, or any other opening into a building, with the exception of sub-floor ventilation		
	Appliances up to 150 MJ/h input	500	300
	All fan assisted appliances in the direction of discharge	-	1500
k	From a mechanical air inlet, including a spa fan	1500	1000
n	Vertically below an openable window, non-mechanical air inlet or any other opening into a building, with the exception of See table sub-floor ventilation		
	For space heaters up to 50 MJ/h input	150	150
	For other appliances up to 50 MJ/h input	500	500
	For appliances over 50 MJ/h input and up to 150 MJ/h	1000	1000
	For appliances over 150 MJ/h input	1500	1500

- NOTES:**
- All distances are measured vertically or horizontally along the wall to a point in line with the nearest part of the terminal.
 - Prohibited area below electricity meter or fuse box extends to ground level.
 - Flue terminal under covered area:
 - The covered area or recess shall be open on at least two sides.
 - Fan assisted flue appliance shall have at least one side open and the terminal shall be within 500 mm of the opening and discharging in the direction of the opening.
 - Clearance from a flue terminal to a LP cylinder shall be a minimum of 1 meter.

MINIMUM CLEARANCES REQUIRED FOR BALANCED FLUE TERMINALS OR THE FLUE TERMINALS OF OUTDOOR APPLIANCES

Figure 4.3 Minimum Clearances for Termination

C. Approved Pipe

This appliance is approved for use with Hearth & Home Technologies DVP venting systems. Refer to Section 12.A for vent component information and dimensions.

DO NOT mix pipe, fittings or joining methods from different manufacturers.

The pipe is tested to be run inside an enclosed wall. There is no requirement for inspection openings at each joint within the wall.

WARNING! Risk of Fire or Asphyxiation. This appliance requires a separate vent. **DO NOT** vent to a pipe serving a separate solid fuel burning appliance.

D. Use of Elbows

Diagonal runs have both vertical and horizontal vent aspects when calculating the effects. Use the rise for the vertical aspect and the run for the horizontal aspect. See Figure 4.4.

Two 45° elbows may be used in place of one 90° elbow. On 45° runs, one foot of diagonal is equal to 8-1/2 in. (216 mm) horizontal run and 8-1/2 in. (216 mm) vertical run. A length of straight pipe is allowed between two 45° elbows. See Figure 4.4.

Figure 4.5 shows the vertical and horizontal offsets for DVP elbows.

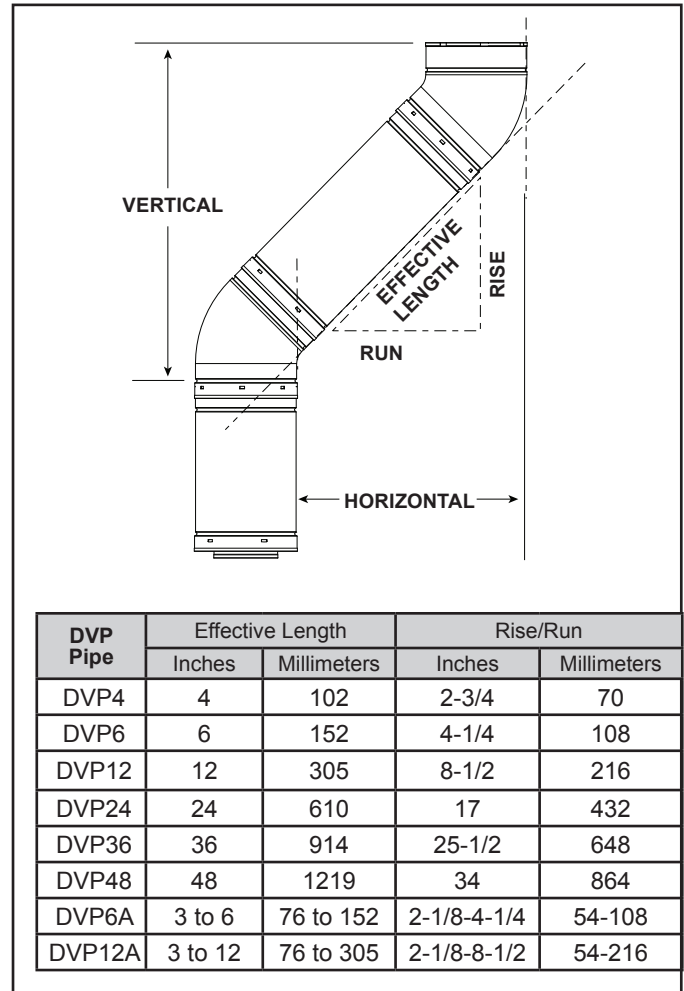

Figure 4.4

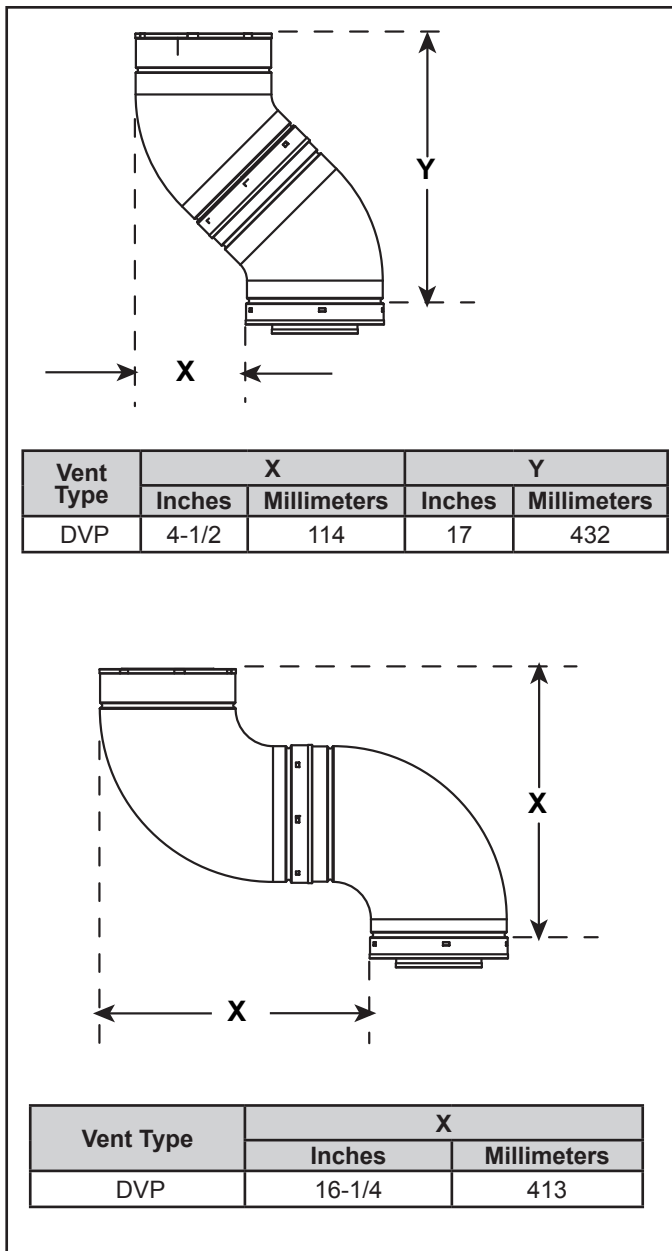

Figure 4.5 Vertical and Horizontal Offset for DVP Elbows

E. Measuring Standards

Vertical and horizontal measurements listed in the vent diagrams were made using the following standards:

- Pipe measurements are shown using the effective length of pipe. See Section 12.A for information on effective length of pipe components.
- Horizontal terminations are measured to the outside mounting surface (flange of termination cap) (see Figure 4.6).
- Vertical terminations are measured to top of last section of pipe. See Figure 4.7.
- Horizontal pipe installed level with no rise.

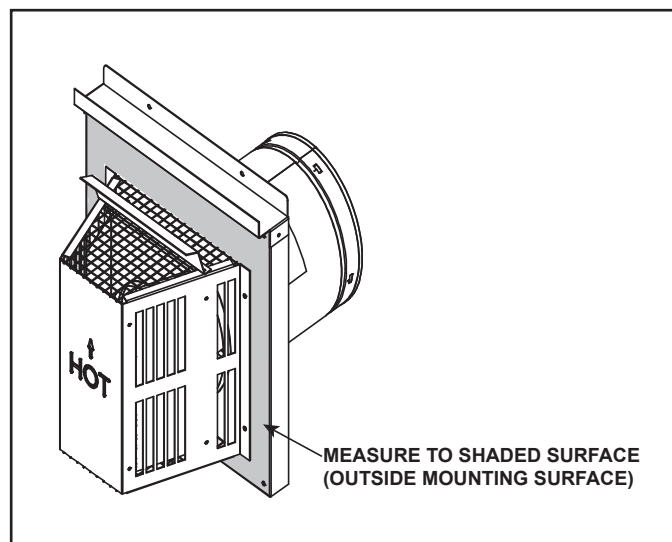

Figure 4.6 Measure to Outside Mounting Surface

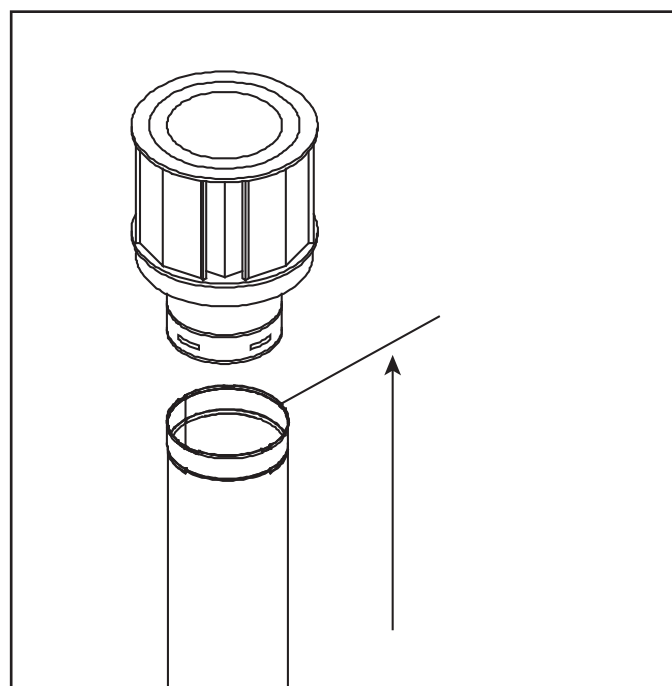

Figure 4.7. Measure to Top of Last Section of Pipe

F. Vent Diagrams

General Rules:

- SUBTRACT 3 ft. (914 mm) from the total H measurement for each 90° elbow installed horizontally.
- SUBTRACT 1-1/2 ft. (457 mm) from the total H measurement for each 45° elbow installed horizontally.
- A maximum of three 90° elbows (or six 45° elbows) may be used in any vent configuration. Some elbows may be installed horizontally. See Figure 4.18.
- Elbows may be placed back to back anywhere in the system.
- Any 90° elbow may be replaced with two back to back 45° elbows.
- When penetrating a combustible wall, a wall shield firestop must be installed.
- When penetrating a combustible ceiling, a ceiling firestop must be installed.
- Horizontal runs of vent do not require vertical rise; horizontal runs may be level.
- Horizontal termination cap should have a 1/4 in. (6 mm) downward slant to allow any moisture in cap to be released. See Figure 4.8.

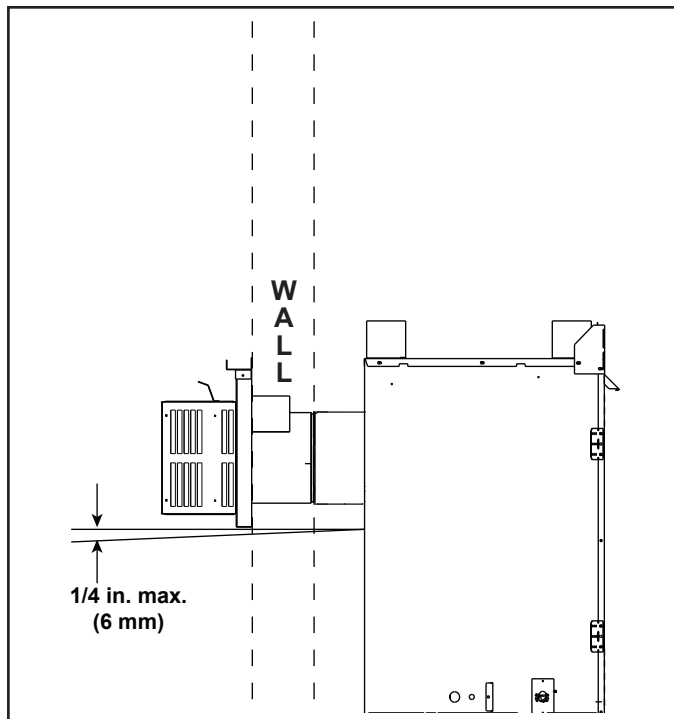

Figure 4.8 Vent Cap - Generic Fireplace Shown

⚠ WARNING



Fire Risk. Explosion Risk.

Do NOT pack insulation or other combustibles between ceiling firestops.

- ALWAYS maintain specified clearances around venting and firestop systems.



- Install wall shield and ceiling firestops as specified.

Failure to keep insulation or other material away from vent pipe may cause fire.

⚠ WARNING



Fire Risk.

- When using DVP-HRC-SS and DVP-HRC-ZC-SS termination caps on top vented fireplaces, a 6 inch minimum vertical vent section is required before installing first elbow.

Flue Components and Terminations

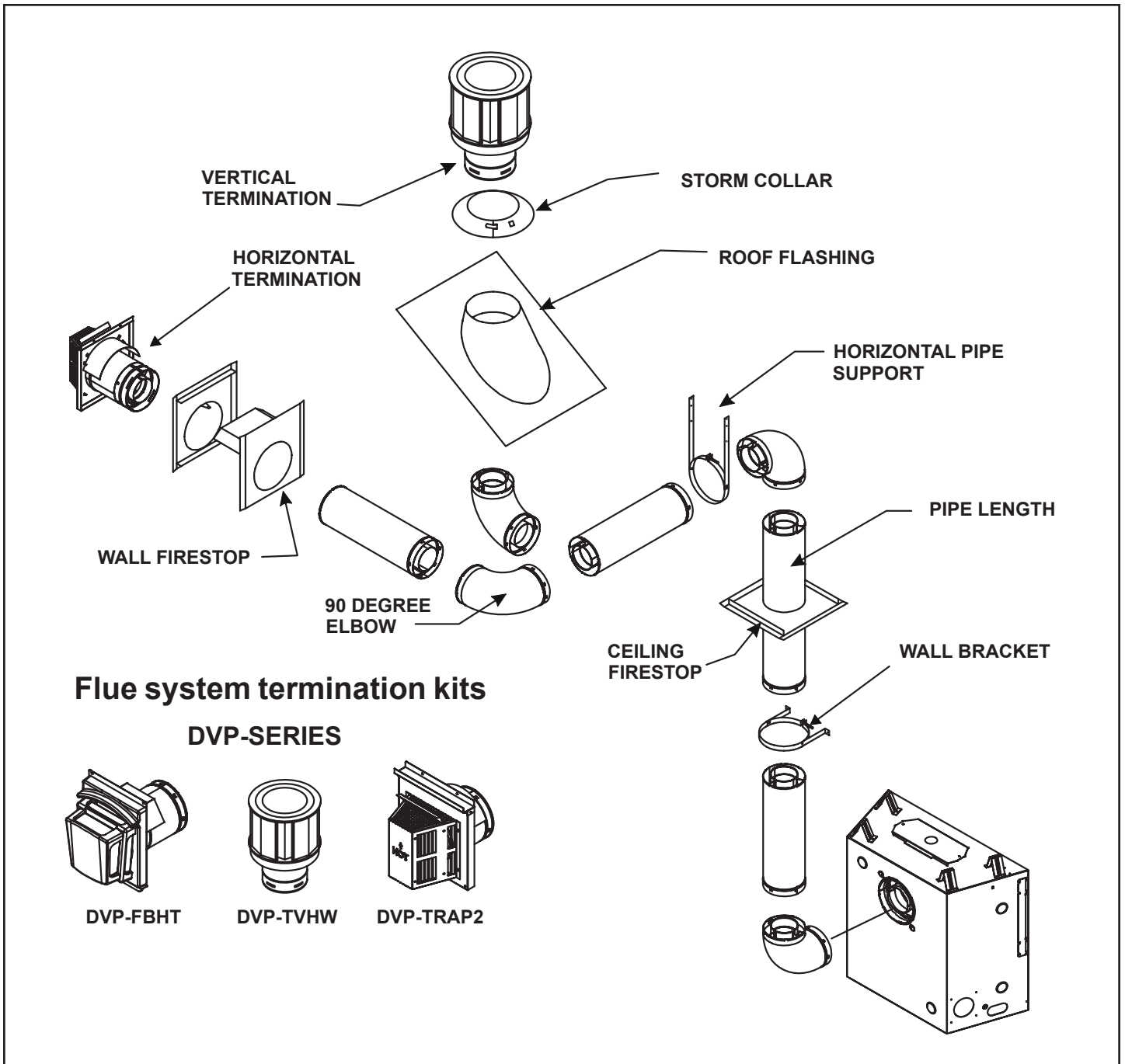

Figure 4.9 Flue Components and Terminations

Top Vent - Horizontal Termination

One Elbow

6X-AU (NG/LP)			
V ₁ Minimum		H ₁ Maximum	
6 in.	152	2 ft.	610 mm
1 ft.	305 mm	3 ft.	914 mm
2 ft.	610 mm	6 ft.	1.8 m
3 ft.	914 mm	11 ft.	3.4 m
4 ft.	1.2 m	16 ft.	4.9 m
5 ft.	1.5 m	20 ft.	6.1 m
V ₁ + H ₁ = 40 ft. (12.2 m) Maximum H ₁ = 20 ft. (6.1 m) Maximum			

6X-AU (ULPG)			
V ₁ Minimum		H ₁ Maximum	
1 ft.	305 mm	1 ft.	305 mm
2 ft.	610 mm	4 ft.	1.2 m
3 ft.	914 mm	6 ft.	1.8 m
4 ft.	1.2 m	8 ft.	2.4 m
5 ft.	1.5 m	10 ft.	3.0 m
V ₁ + H ₁ = 40 ft. (12.2 m) Maximum H ₁ = 10 ft. (3.0 m) Maximum			

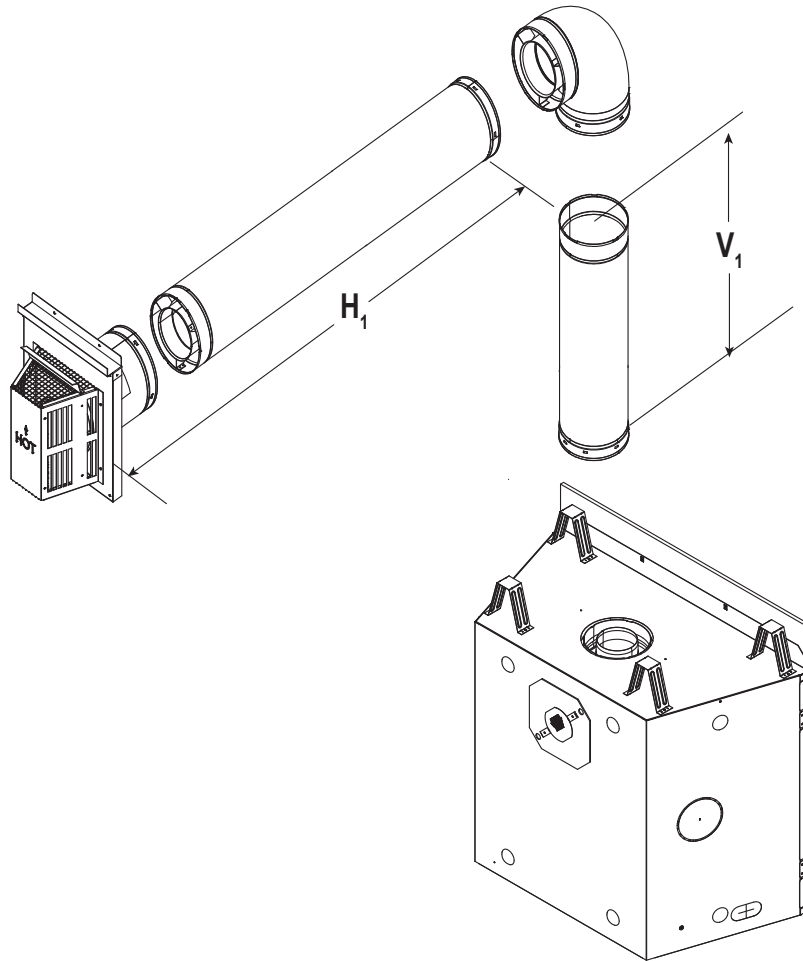

Figure 4.10

Top Vent - Horizontal Termination - (continued)

Two Elbows

6X-AU (NG/LP)			
V ₁ Minimum		H ₁ + H ₂ Maximum	
6 in.	152 mm	1 ft.	305 mm
1 ft.	305 mm	2 ft.	610 mm
2 ft.	610 mm	4 ft.	1.2 m
3 ft.	914 mm	8 ft.	2.4 m
4 ft.	1.2 m	12 ft.	3.7 m
6 ft.	1.8 m	20 ft.	6.1 m
V ₁ + H ₁ + H ₂ = 40 ft. (12.2 m) Maximum H ₁ + H ₂ = 20 ft. (6.1 m) Maximum			

6X-AU (ULPG)			
V ₁ Minimum		H ₁ + H ₂ Maximum	
1 ft.	305 mm	1 ft.	305 mm
2 ft.	610 mm	3 ft.	914 mm
3 ft.	914 mm	5 ft.	1.5m
4 ft.	1.2 m	7 ft.	2.1 m
6 ft.	1.8 m	11 ft.	3.4 m
V ₁ + H ₁ + H ₂ = 40 ft. (12.2 m) Maximum H ₁ + H ₂ = 11 ft. (3.4 m) Maximum			

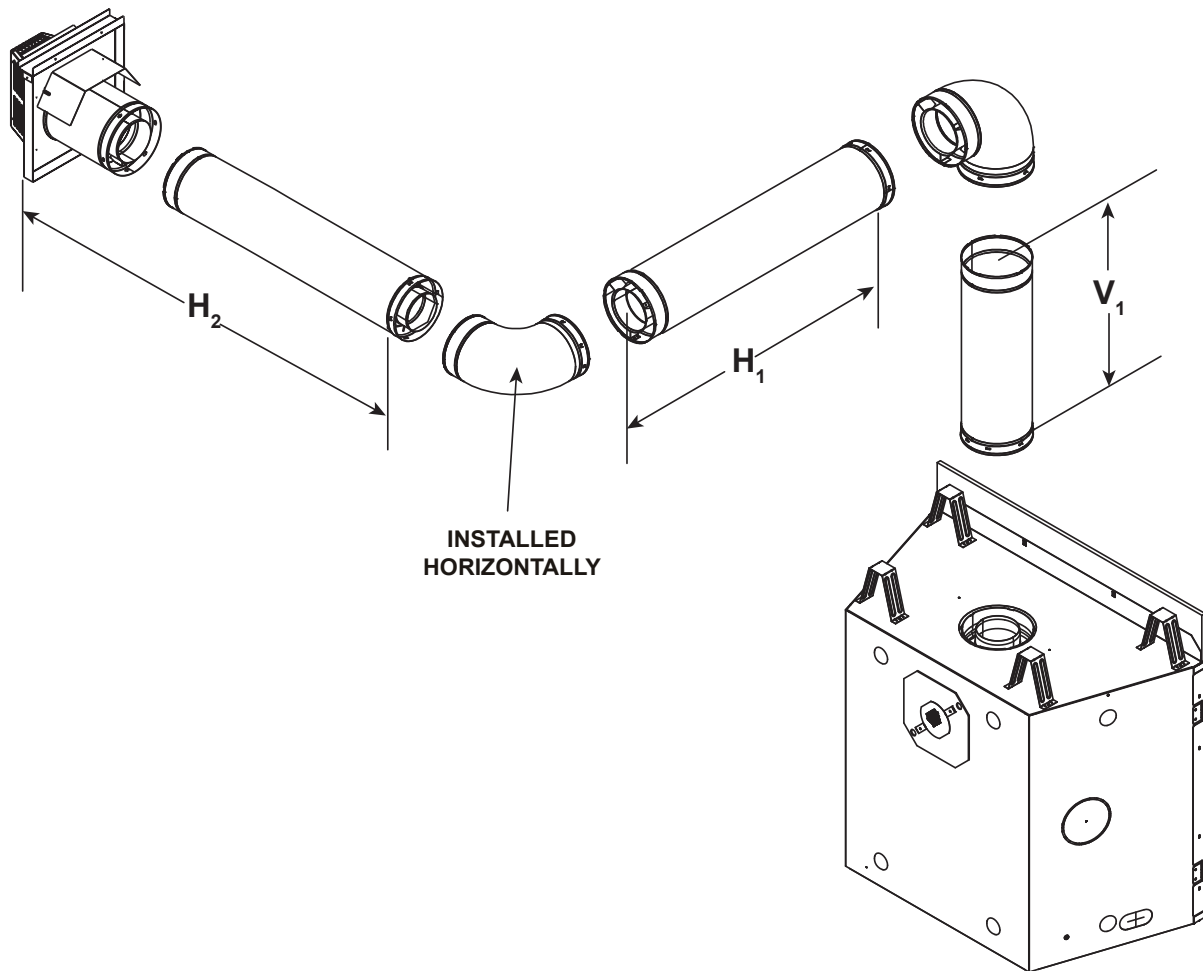

Figure 4.11

Top Vent - Horizontal Termination - (continued)

Three Elbows

6X-AU (NG/LP)							
V ₁ Min.		H ₁ Max.		V ₂ Min.		H ₂ Max.	
6 in.	152 mm	2 ft	610 mm	6 in.	152 mm	2 ft.	610 mm
1 ft.	305 mm	4 ft.	1.2 m	1 ft.	305 mm	4 ft.	1.2 m
2 ft.	610 mm	8 ft.	2.4 m	2 ft.	610 mm	8 ft.	2.4 m
3 ft.	914 mm	12 ft.*	3.7 m*	3 ft.	914 mm	12 ft.*	3.7 m*
4 ft.	1.2 m	16 ft.*	4.9 m*	4 ft.	1.2 m	16 ft.*	4.9 m*
*H ₁ + H ₂ = 20 ft. (6.1 m) Maximum				V ₁ + V ₂ + H ₁ + H ₂ = 40 ft. (12.2 m) Maximum			

6X-AU (ULPG)							
V ₁ Min.		H ₁ Max.		V ₂ Min.		H ₂ Max.	
1 ft.	305 mm	2 ft.	610 mm	1 ft.	305 mm	2 ft.	610 mm
2 ft.	610 mm	4 ft.	1.2 m	2 ft.	610 mm	4 ft.	1.2 m
3 ft.	914 mm	6 ft.	1.8 m	3 ft.	914 mm	6 ft.	1.8 m
4 ft.	1.2 m	8 ft.	2.4 m	4 ft.	1.2 m	8 ft.	2.4 m
*H ₁ + H ₂ = 16 ft. (4.9 m) Maximum				V ₁ + V ₂ + H ₁ + H ₂ = 40 ft. (12.2 m) Maximum			

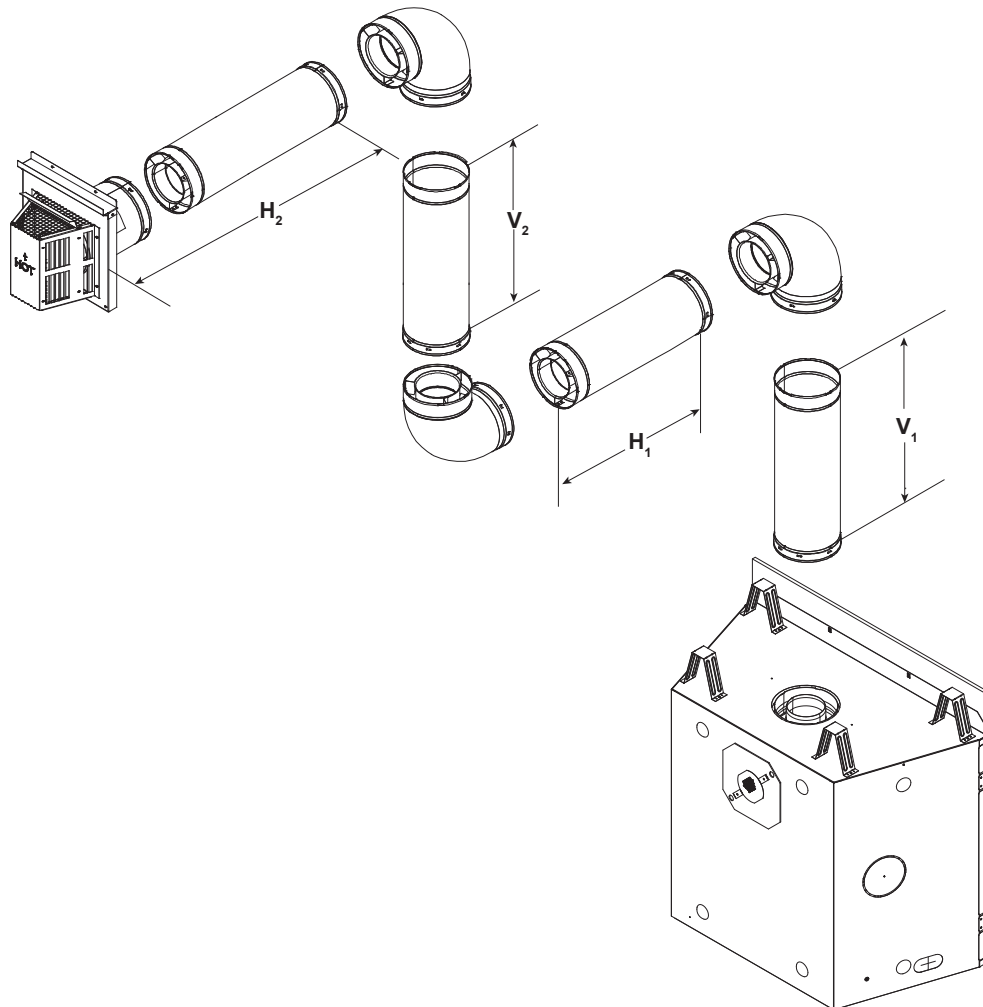

Figure 4.12

Top Vent - Vertical Termination

No Elbow

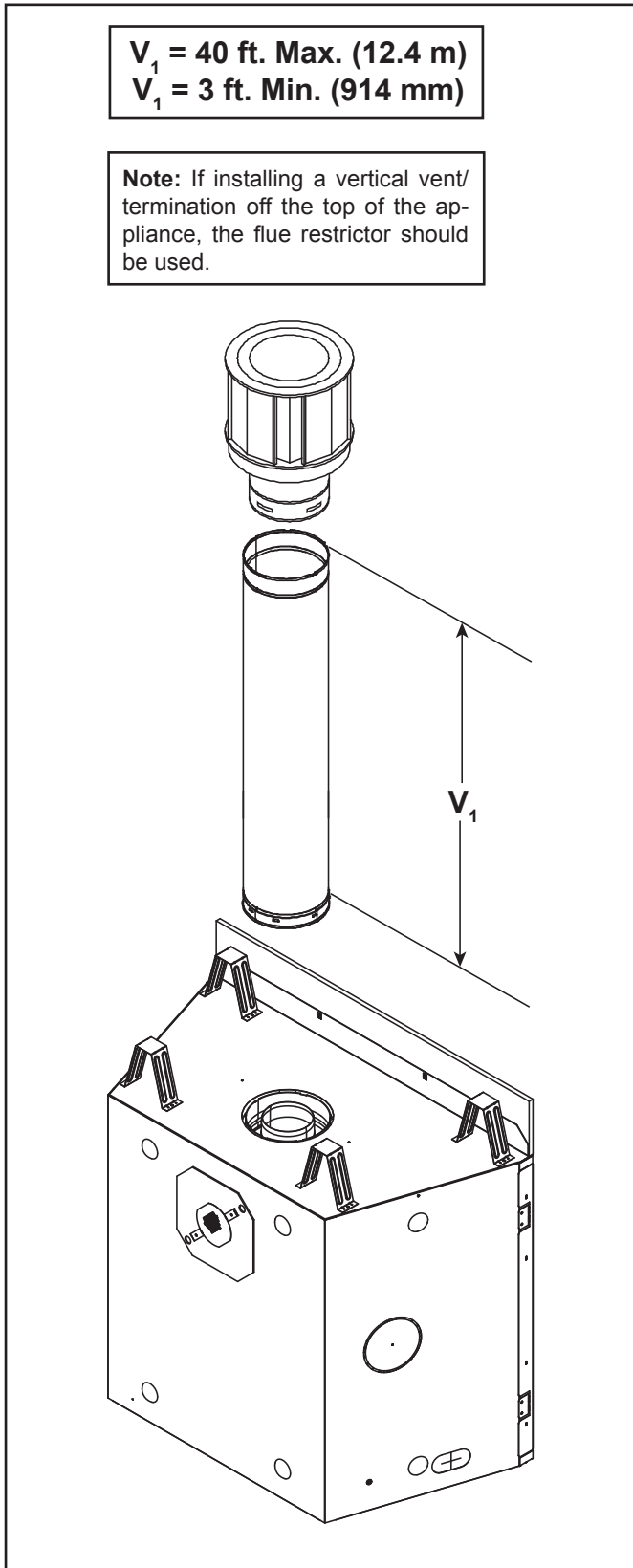

Figure 4.13

Flue Restrictor Instructions

1. Remove the top piece of refractory, if already installed. See Figure 4.14.
2. Orientate and align the two pieces of the flue restrictor as shown in Figure 4.16.

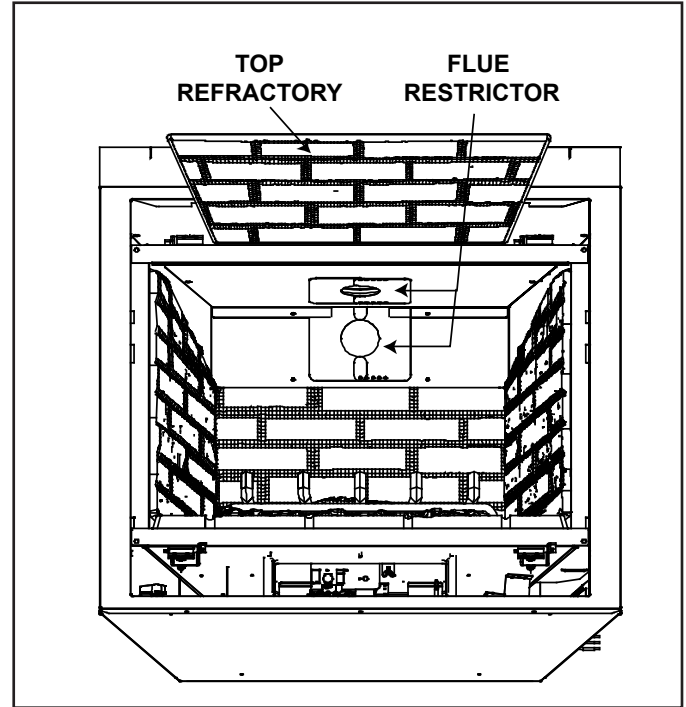

Figure 4.14

3. Match the amount of vertical you have in the system with the chart to find the appropriate position to set the flue restrictor. See Figure 4.15 and 4.16.
4. Center the two flue restrictor pieces on the vent at the setting selected in step 3 and secure in place by using two self-tapping screws. See Figure 4.14.
5. Reinstall the refractory.

Vertical	TOP VENT		REAR VENT	
	NG	LP/ULPG	NG	LP/ULPG
4 ft. (1.2 m)	1-1	No Restrictor	No Restrictor	No Restrictor
8 ft. (2.4 m)	2-2	1-2	1-1	No Restrictor
15 ft. (4.6 m)	3-2	3-2	2-2	1-2
20 ft. (6.0 m)	3-2	3-2	3-2	3-2
25 ft. (7.6 m)	3-2	3-2	3-2	3-2
30 ft. (9.1 m)	3-3	3-3	3-3	3-3
35 ft. (10.7 m)	3-4	3-4	3-4	3-3
40 ft. (12.2 M)	3-4	3-4	3-4	3-4

Figure 4.15

Top Vent - Vertical Termination (continued)

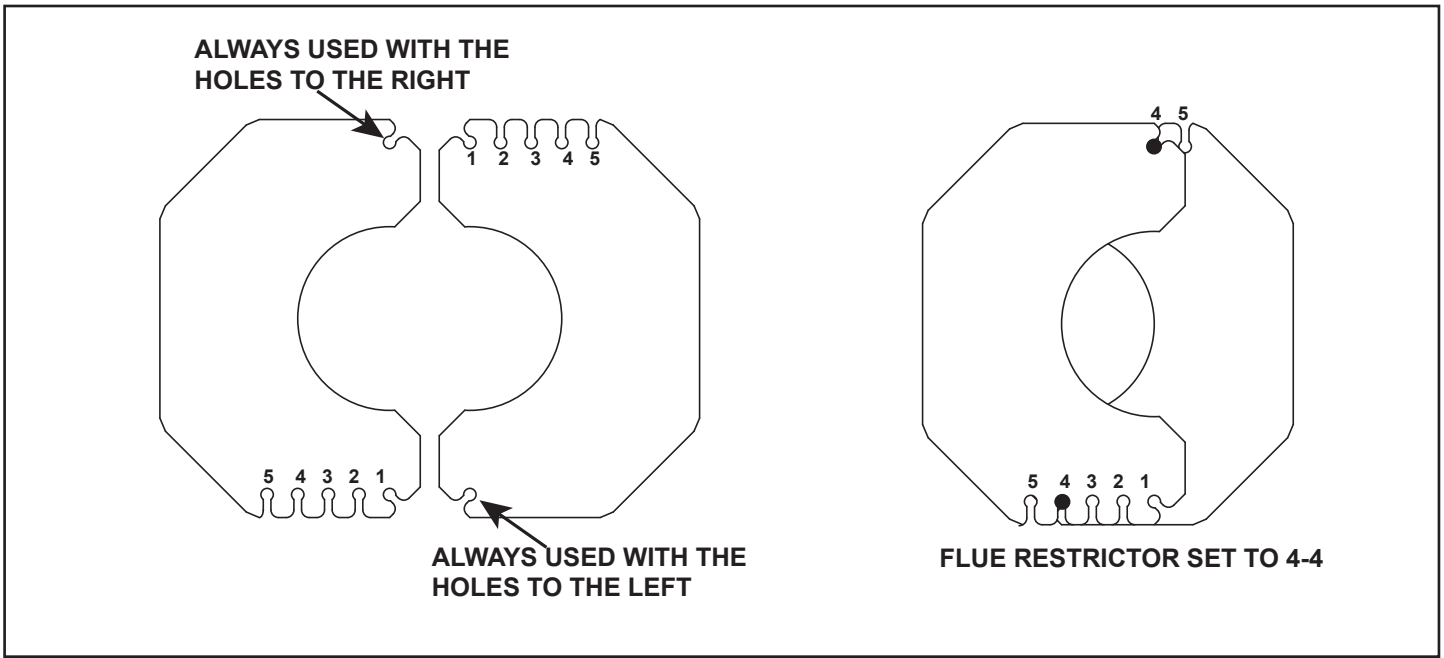
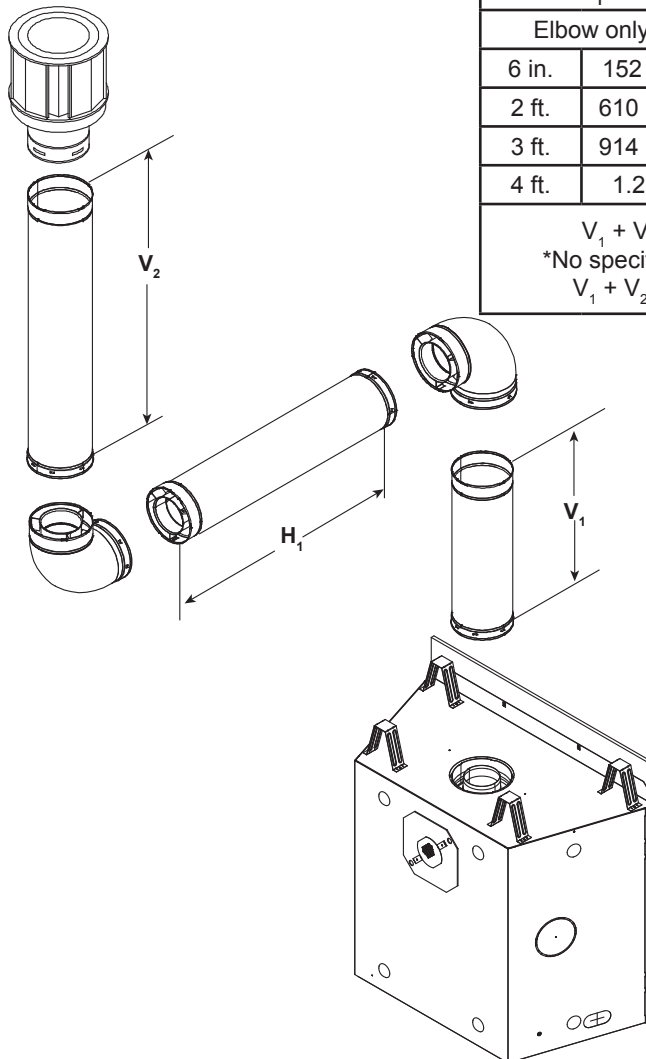

Figure 4.16. Setting the Flue Restrictor

Two Elbows



V_1		H_1 Maximum		V_2	$V_1 + V_2$ Min.	
Elbow only		2 ft.	610 mm	*	*	*
6 in.	152 mm	6 ft.	1.8 m	*	*	*
2 ft.	610 mm	11 ft.	3.4 m	*	*	*
3 ft.	914 mm	16 ft.	4.9 m	*	*	*
4 ft.	1.2 m	20 ft.	6.1 m	*	*	*
$V_1 + V_2 + H_1 = 50$ ft. (15.2 m) Maximum *No specific restrictions on this value EXCEPT $V_1 + V_2 + H_1$ cannot exceed 50 ft (15.2 m)						

Figure 4.17

Top Vent - Vertical Termination - (continued)

Three Elbows

V_1		$H_1 + H_2$		V_2	$V_1 + V_2$ Minimum		$H_1 + H_2$ Maximum	
Elbow only		1 ft.	305 mm	*	*	*	1 ft.	305 mm
6 in.	152 mm	2 ft.	610 mm	*	*	*	2 ft.	610 mm
1 ft.	305 mm	2 ft.	610 mm	*	*	*	2 ft.	610 mm
2 ft.	610 mm	4 ft.	1.2 m	*	*	*	4 ft.	1.2 m
3 ft.	914 mm	9 ft.	2.7 m	*	*	*	9 ft.	2.7 m
4 ft.	1.2 m	18 ft.	5.5 m	*	*	*	18 ft.	5.5 m
$H_1 + H_2 = 20$ ft. (6.1 m) Maximum				$V_1 + V_2 + H_1 + H_2 = 40$ ft. (12.2 m) Maximum				
* No specific restrictions on this value EXCEPT $V_1 + V_2 + H_1 + H_2$ cannot exceed 40 ft. (12.2 m).								

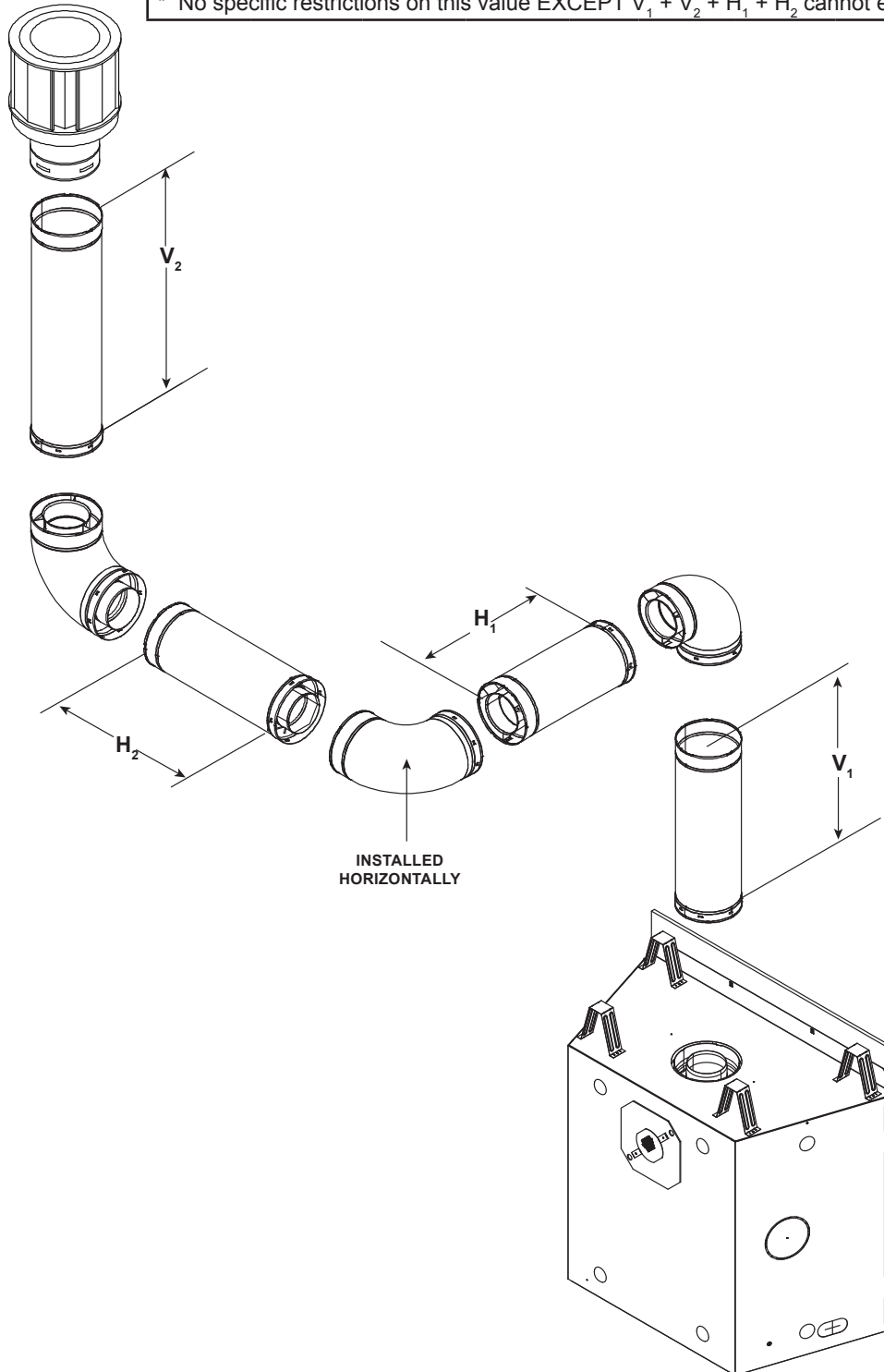

Figure 4.18

Rear Vent - Horizontal Termination

No Elbow

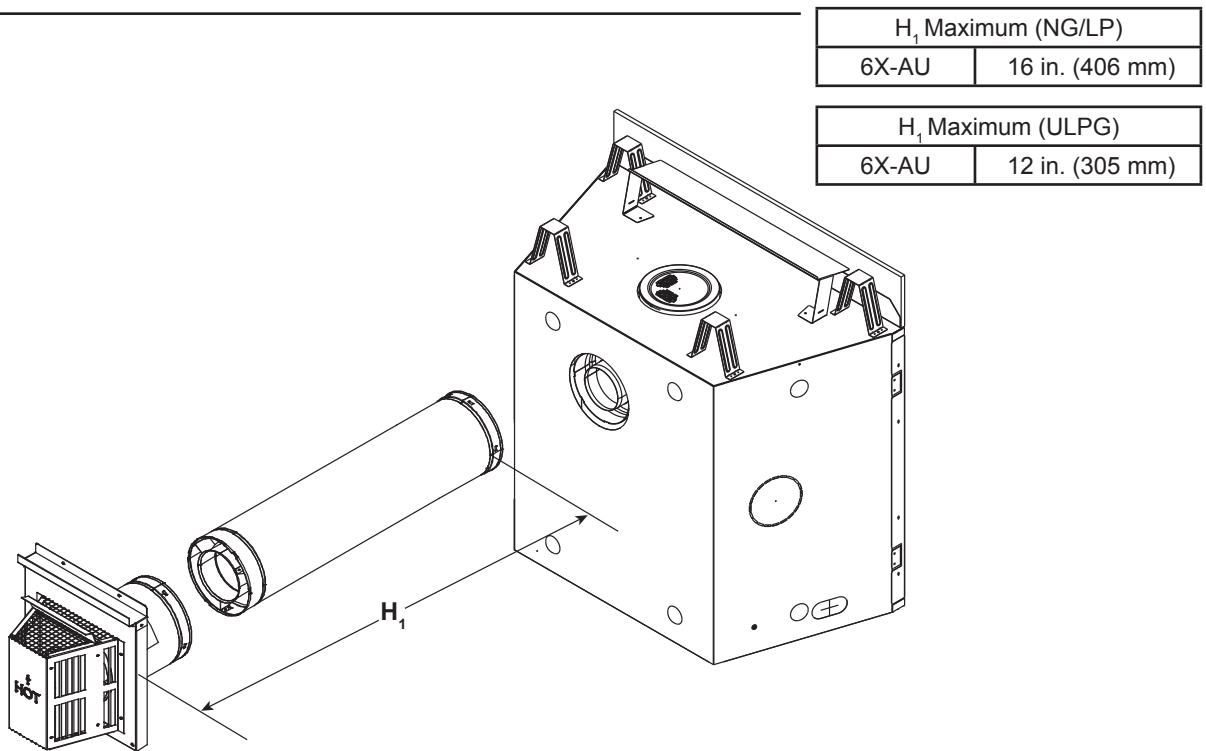

Figure 4.19

One 45° Elbow

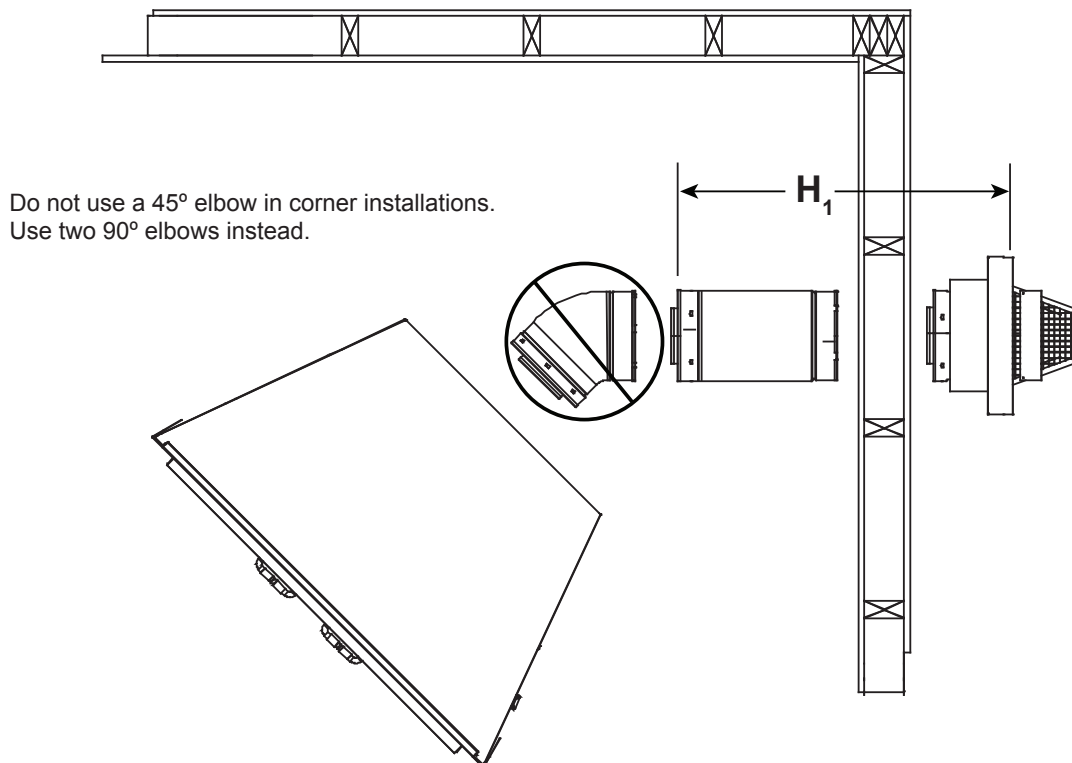

Figure 4.20

Rear Vent - Horizontal Termination - (continued)

Two Elbows

H ₁ Maximum		V ₁ Minimum		H ₂		H ₁ + H ₂ Maximum	
6 in.	152 mm	Back to Back 90° Elbows		1 ft.	305 mm	1.5 ft.	457 mm
1 ft.	305 mm	6 in.	152 mm	1.5 ft.	457 mm	2.5 ft.	762 mm
2 ft.	610 mm	1 ft.	305 mm	2 ft.	610 mm	4 ft.	1.2 m
3 ft.	914 mm	2 ft.	610 mm	3 ft.	914 mm	6 ft.	1.8 m
3 ft.	914 mm	3 ft.	914 mm	7 ft.	2.1 m	10 ft.	3.0 m
3 ft.	914 mm	4 ft.	1.2 m	12 ft.	3.7 m	15 ft.	4.6 m
3 ft.	914 mm	5 ft.	1.5 m	17 ft.	5.2 m	20 ft.*	6.1 m*
V ₁ + H ₁ + H ₂ = 40 ft. (12.2 m) Maximum H ₁ = 3 ft. (914 mm) Maximum *H ₁ + H ₂ = 20 ft (6.1 m) Maximum							

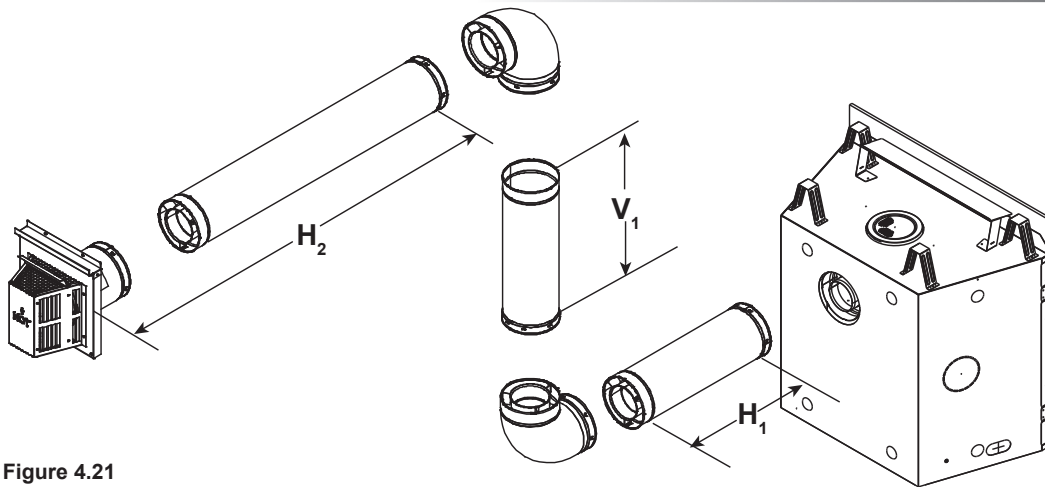

Figure 4.21

Three Elbows

H ₁ Maximum		V ₁ Minimum		H ₂ + H ₃		H ₁ + H ₂ + H ₃ Max.	
0 ft.	0 mm	Back to Back 90° Elbows		1 ft.	305 mm	1 ft.	305 mm
1 ft.	305 mm	6 in.	152 mm	1.5 ft.	457 mm	2.5 ft.	762 mm
2 ft.	610 mm	1 ft.	305 mm	2 ft.	610 mm	4 ft.	1.2 m
3 ft.	914 mm	2 ft.	610 mm	3 ft.	914 mm	6 ft.	1.8 m
3 ft.	914 mm	3 ft.	914 mm	7 ft.	2.1 m	10 ft.	3.0 m
3 ft.	914 mm	4 ft.	1.2 m	12 ft.	3.7 m	15 ft.	4.6 m
3 ft.	914 mm	5 ft.	1.5 m	17 ft.	5.2 m	20 ft.	6.1 m
V ₁ + H ₁ + H ₂ + H ₃ = 40 ft. (12.2 m) Maximum H ₁ = 3 ft. (914 mm) Maximum H ₁ + H ₂ + H ₃ = 20 ft. (6.1 m) Maximum							

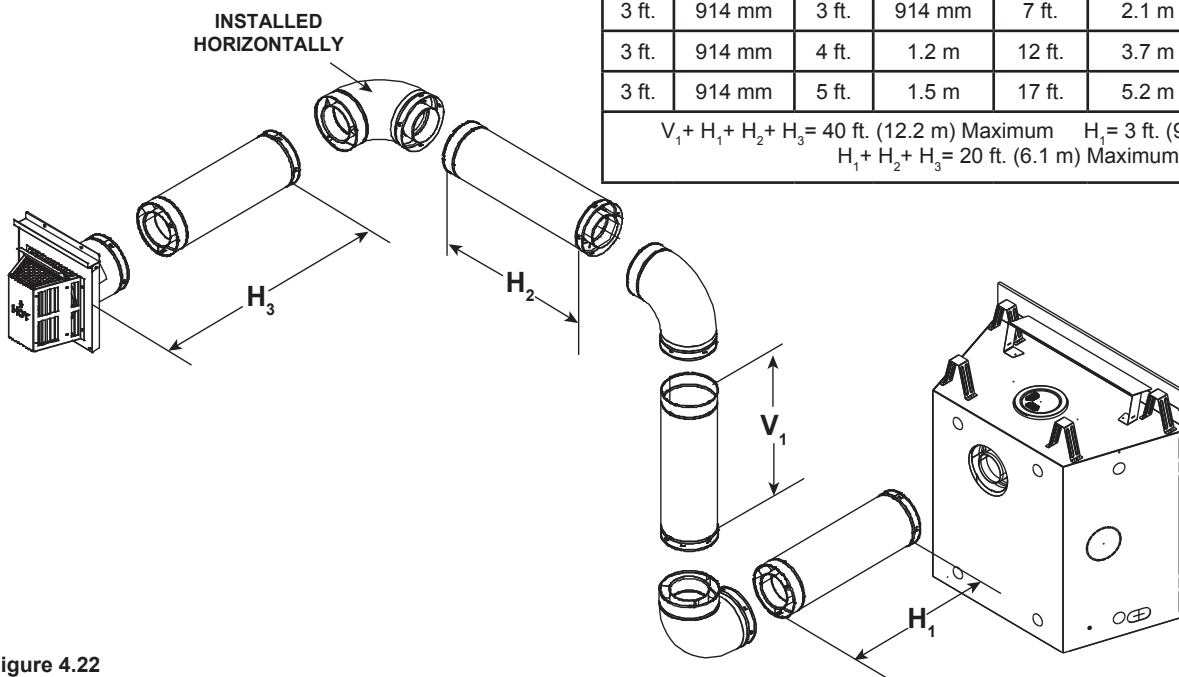
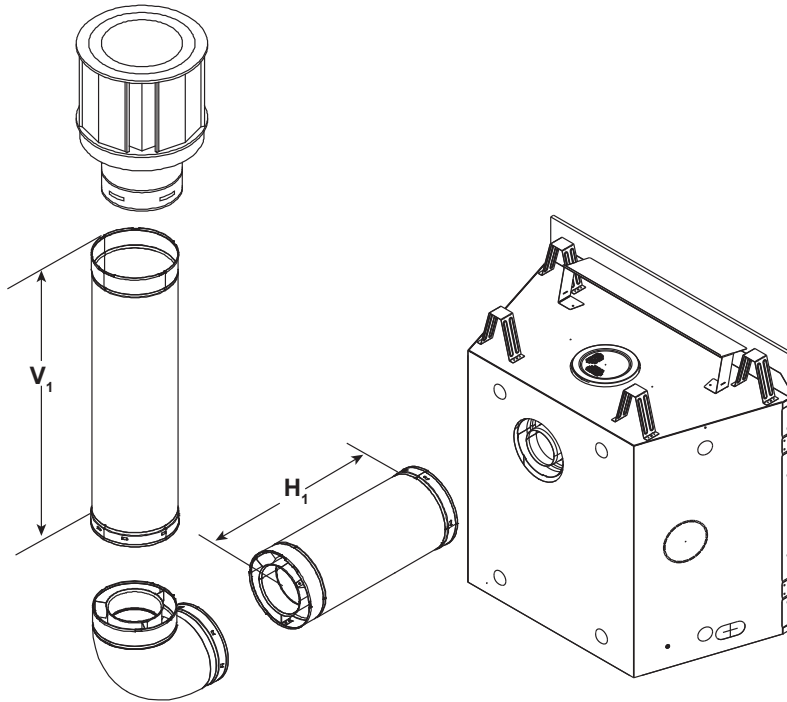

Figure 4.22

Rear Vent - Vertical Termination

One Elbow



V ₁ Minimum		H ₁ Maximum	
6 in.	152 mm	2 ft.	610 mm
1 ft.	305 mm	3 ft.	914 mm
2 ft.	610 mm	5 ft.	1.5 m
3 ft.	914 mm	7 ft.	2.1 m
4 ft.	1.2 m	8 ft.	2.4 m
5 ft.	1.5 m	8 ft.	2.4 m
V ₁ + H ₁ = 40 ft. (12.2 m) Maximum			
H ₁ = 8 ft. (2.4 m) Maximum			

Figure 4.23

Two Elbows

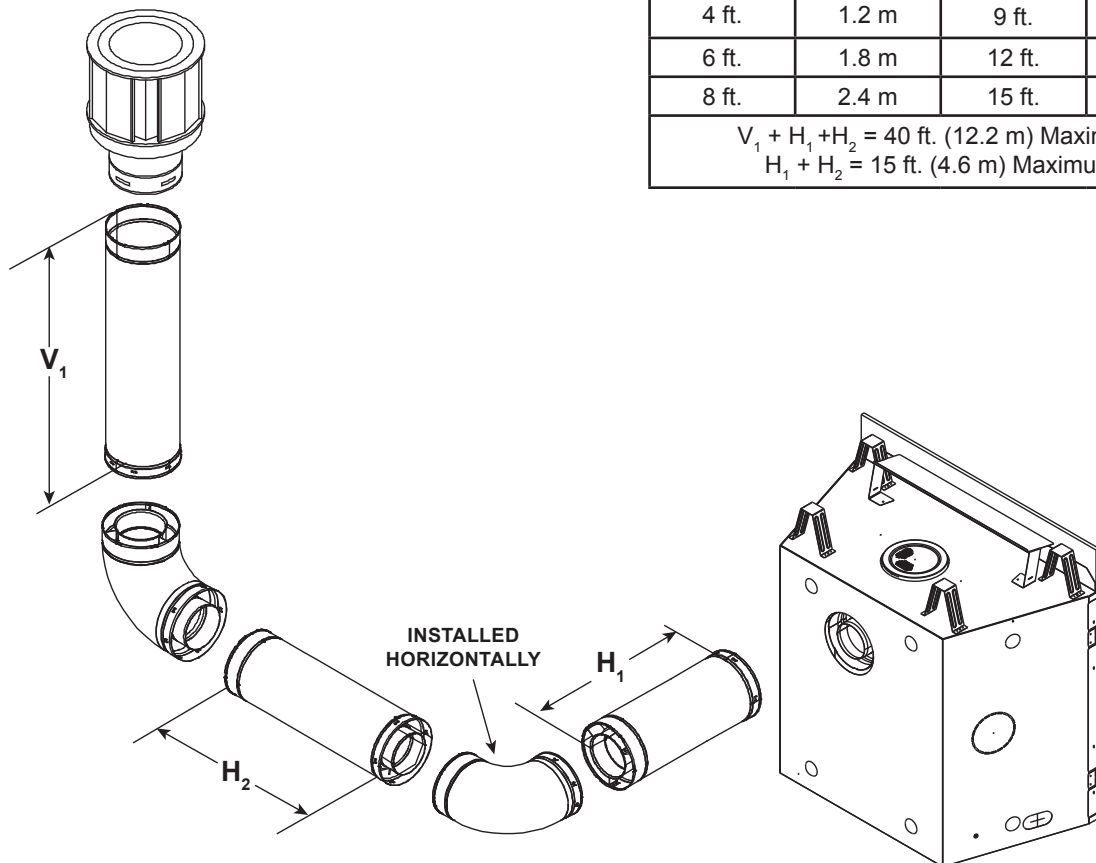

V ₁ Minimum		H ₁ + H ₂ Maximum	
Back to Back 90° Elbows		3 ft.	914 mm
2 ft.	610 mm	6 ft.	1.8 m
4 ft.	1.2 m	9 ft.	2.7 m
6 ft.	1.8 m	12 ft.	3.7 m
8 ft.	2.4 m	15 ft.	4.6 m
V ₁ + H ₁ + H ₂ = 40 ft. (12.2 m) Maximum			
H ₁ + H ₂ = 15 ft. (4.6 m) Maximum			

Figure 4.24

Rear Vent - Vertical Termination - (continued)

Three Elbows

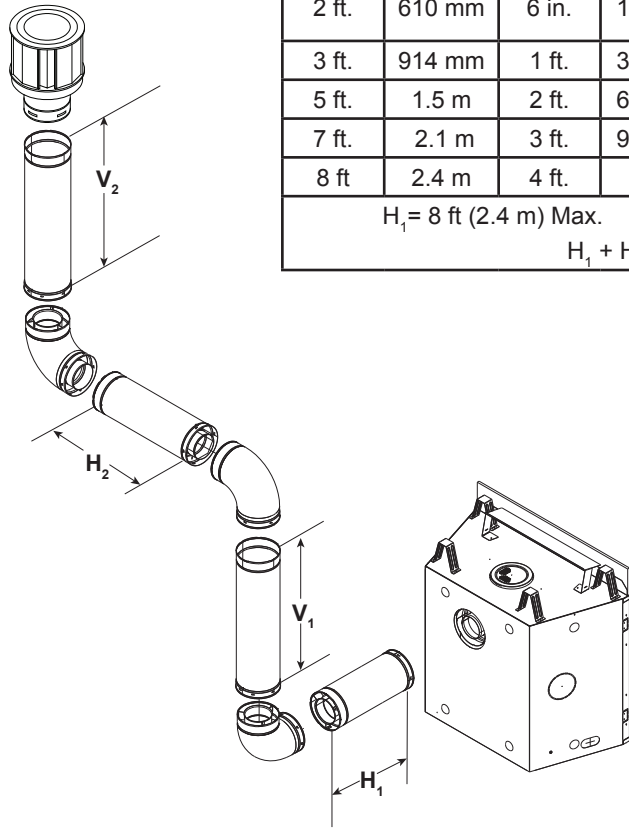

H_1 Maximum		V_1 Minimum		H_2		$H_1 + H_2$ Maximum	
2 ft.	610 mm	6 in.	152 mm	2 ft.	610 mm	4 ft.	1.2 m
3 ft.	914 mm	1 ft.	305 mm	4 ft.	1.2 m	7 ft.	2.1 m
5 ft.	1.5 m	2 ft.	610 mm	6 ft.	1.8 m	11 ft.	3.4 m
7 ft.	2.1 m	3 ft.	914 mm	8 ft.	2.4 m	15 ft.	4.6 m
8 ft.	2.4 m	4 ft.	1.2 m	10 ft.	3.1 m	18 ft.	5.5 m
$H_1 = 8 \text{ ft. (2.4 m) Max.}$ $V_1 + V_2 + H_1 + H_2 = 40 \text{ ft. (12.2 m) Max.}$ $H_1 + H_2 = 20 \text{ ft. (6.1 m) Max.}$							

Figure 4.25

Three Elbows

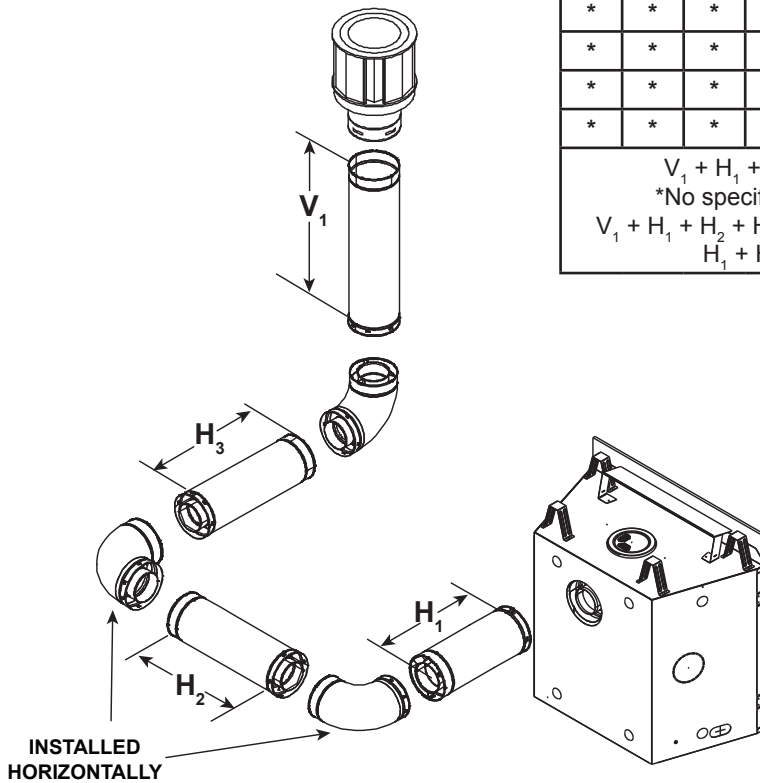

H_1	H_2	H_3	V_1 Minimum		$H_1 + H_2 + H_3$ Maximum	
*	*	*	8 ft.	2.4 m	6 ft.	1.8 m
*	*	*	9 ft.	2.7 m	7 ft.	2.1 m
*	*	*	10 ft.	3.1 m	8 ft.	2.4 m
*	*	*	10 ft.	3.1 m	8 ft.	2.4 m
$V_1 + H_1 + H_2 + H_3 = 40 \text{ ft. (12.2 m) Maximum}$ *No specific restrictions on this value EXCEPT $V_1 + H_1 + H_2 + H_3$ cannot exceed 40 ft. (12.2 m) Maximum $H_1 + H_2 + H_3 = 8 \text{ ft. (2.4 m) Maximum}$						

Figure 4.26

G. Power Vent Configurations

The PVLP-SLP-AU power vent is approved for use with this appliance.

Table 4.1 below shows the allowable vent length and elbow combinations when using PVLP-SLP-AU. Refer to the PVLP-SLP-AU instruction manual for limitations and appliance specific requirements.

Horizontal Termination									
Total Venting Length (Feet) Includes both horizontal and vertical section of pipe									
# of Elbows	10 ft. (3.05 m)	20 ft. (6.10 m)	30 ft. (9.14 m)	40 ft. (12.19 m)	50 ft. (15.24 m)	60 ft. (18.29 m)	70 ft. (21.34 m)	80 ft. (24.38 m)	90 ft. (27.43 m)
1									
2									
3									
4									
5									
6									
7									
8									
9									
10									
11									
12									

ALLOWABLE
VENT RUNS

NOT
ALLOWED

Table 4.1 Allowable Vent Runs - Horizontal Termination

5 Vent Clearances and Framing

A. Pipe Clearances to Combustibles

WARNING! Risk of Fire! Maintain air space clearance to vent. DO NOT pack insulation or other combustibles:

- Between ceiling firestops
- Between wall shield firestops
- Around vent system

Failure to keep insulation or other material away from vent pipe could cause overheating and fire.

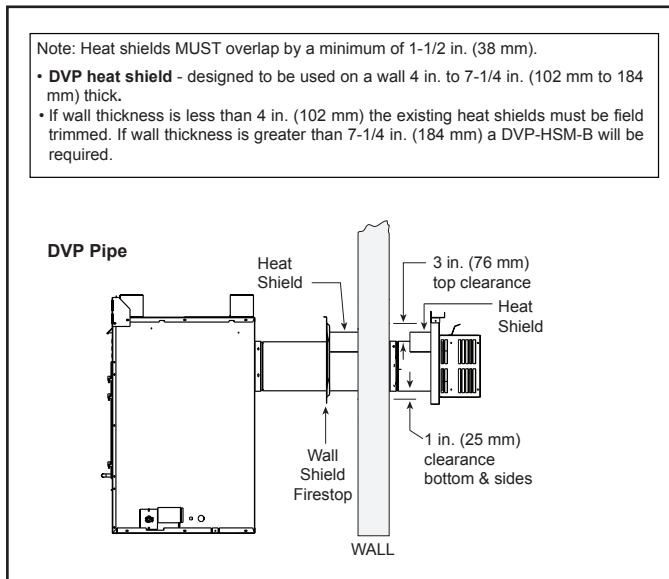

Figure 5.1 Horizontal Venting Clearances To Combustible Materials - Generic Fireplace Shown

B. Wall Penetration Framing/Firestops

Combustible Wall Penetration

Whenever a combustible wall is penetrated, you must frame a hole for the wall shield firestop(s). The wall shield firestop maintains minimum clearances and prevents cold air infiltration.

These clearances are maintained by using a DVP-WS (DVP pipe). See Figure 5.2 for framing instructions.

- For external walls: The wall shield firestop is included with the termination cap assembly.
- For internal walls: A wall shield firestop must be purchased and installed.
- The opening must be framed on all four sides using the same size framing materials as those used in the wall construction.
- DVP pipe - A wall shield firestop is required on one side only on interior walls. If your local inspector requires a wall shield firestop on both sides, then both wall shield firestops must have a heat shield (refer to Section 12.A.) attached to them.
- See Section 7.F. for information for regarding the installation of a horizontal termination cap.

Non-Combustible Wall Penetration

If the hole being penetrated is surrounded by non-combustible materials such as concrete, a hole with diameter one inch greater than the pipe is acceptable.

Whenever a non-combustible wall is penetrated, the wall shield firestop is only required on one side and no heat shield is necessary.

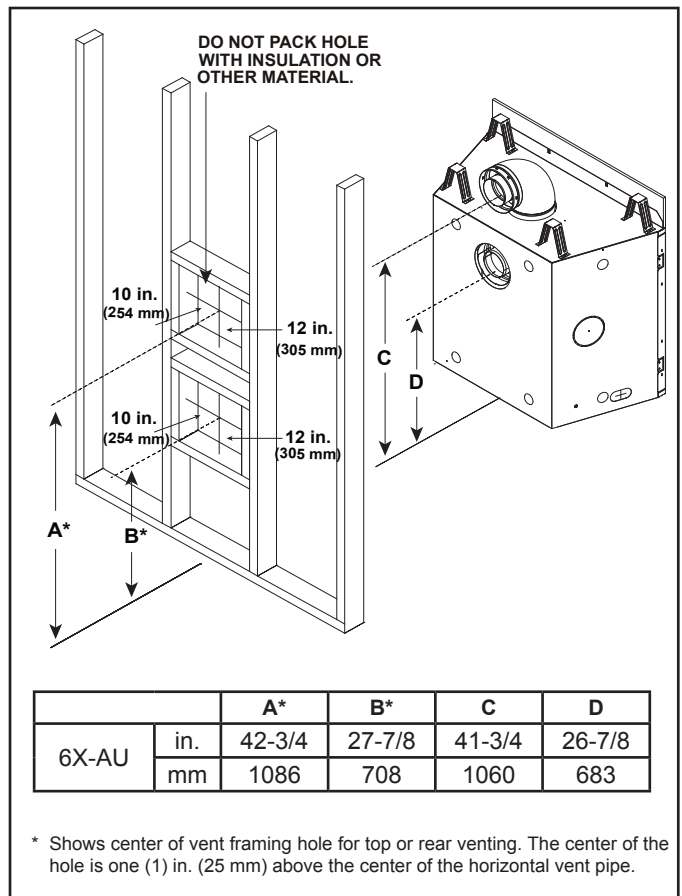

Figure 5.2 Wall Penetration

C. Ceiling Firestop/Floor Penetration Framing

A ceiling firestop **MUST** be used between floors and attics.

- **DVP pipe only** - Frame an opening 10 in. by 10 in. (254 mm by 254 mm) whenever the vent penetrates a ceiling/floor (see Figure 5.3).
- Frame the area with the same sized lumber as used in ceiling/floor joist.
- The ceiling firestop may be installed above or below the ceiling joists when installed with an attic insulation shield. It must be under joists between floors that are not insulated. See Figure 5.4.
- Secure in place with nails or screws.

WARNING! Risk of Fire! DO NOT pack insulation around the vent. Insulation must be kept back from the pipe to prevent overheating.

D. Install Attic Insulation Shield

WARNING! Fire Risk. DO NOT allow loose materials or insulation to touch vent. Hearth & Home Technologies requires the use of an attic shield.

The International Fuel Gas Code requires an attic shield constructed of 26 gauge minimum steel that extends at least 2 in. (51 mm) above insulation.

- Attic insulation shields must meet specified clearances to combustible materials and be secured in place.
- An attic insulation shield kit is available from Hearth & Home Technologies. Contact your dealer to order. Install attic insulation shield according to instructions included with kit.

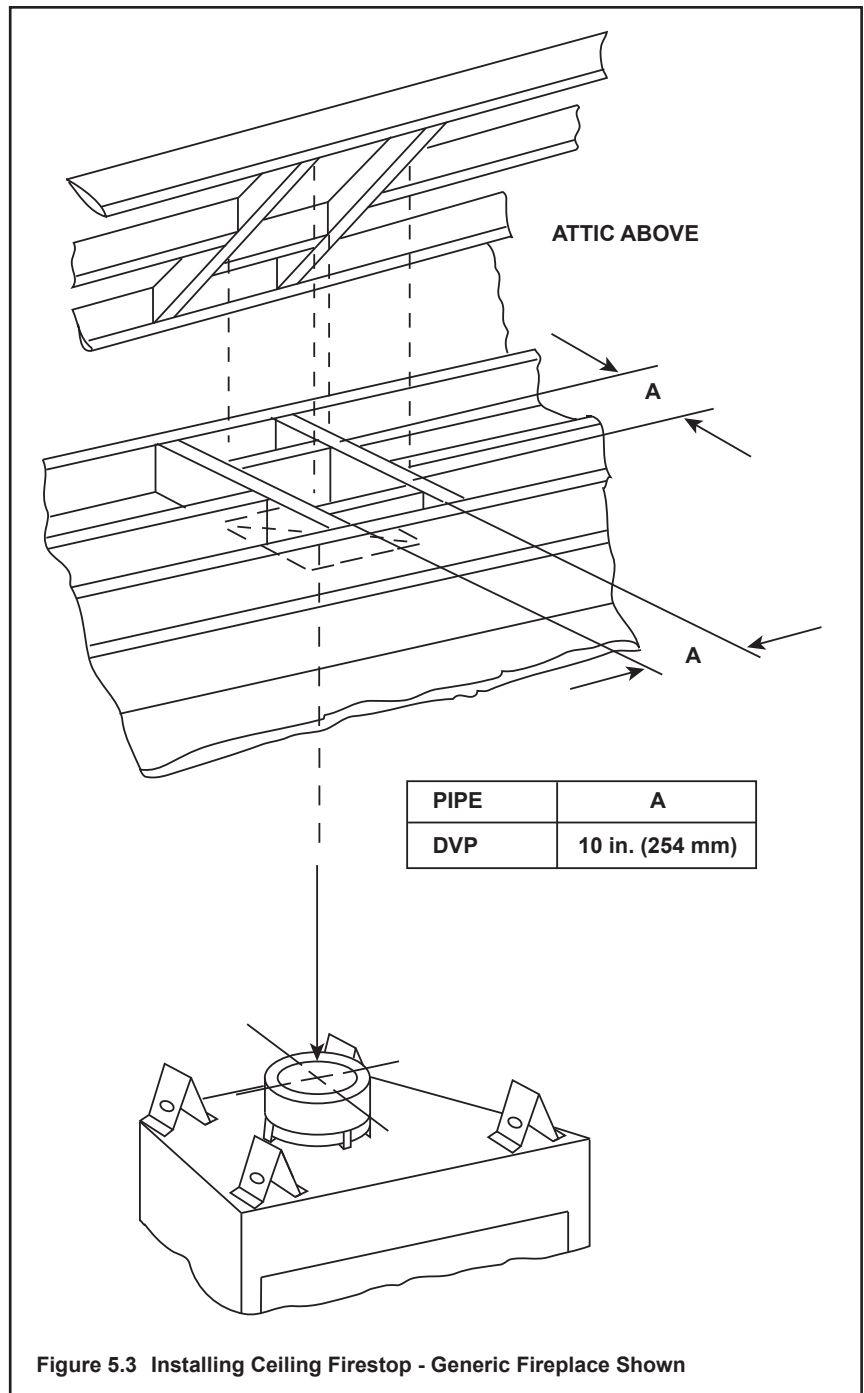

Figure 5.3 Installing Ceiling Firestop - Generic Fireplace Shown

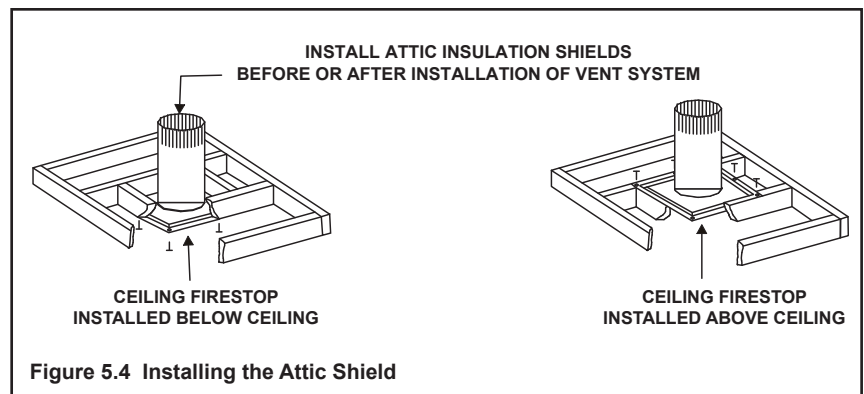

Figure 5.4 Installing the Attic Shield

6 Appliance Preparation

A. Vent Collar Preparation

CAUTION! Risk of Cuts, Abrasions or Flying Debris. Wear protective gloves and safety glasses during installation. Sheet metal edges are sharp.

NOTICE: Once appliance is set up for top or rear venting, it CANNOT be changed at a later time.

Top Vent

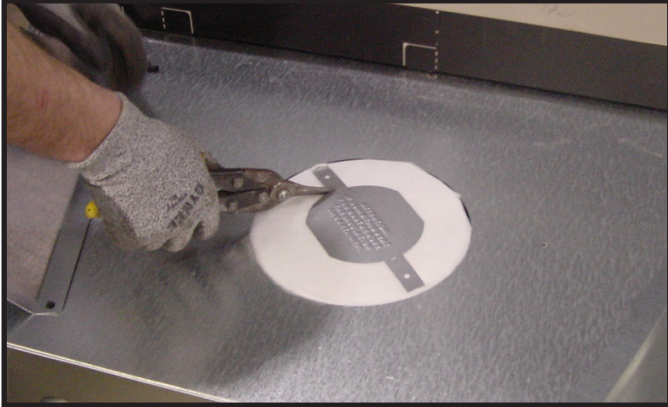

Figure 6.1 (Generic Appliance Shown) Cut the seal strap across the rectangles next to the disk. For rear vent, skip this step.



Figure 6.2 (Generic Appliance Shown) Remove the white gasket material covering the seal cap.



Figure 6.3 (Generic Appliance Shown) Remove the seal cap.

NOTICE: Once the seal cap has been removed it CANNOT be reattached.

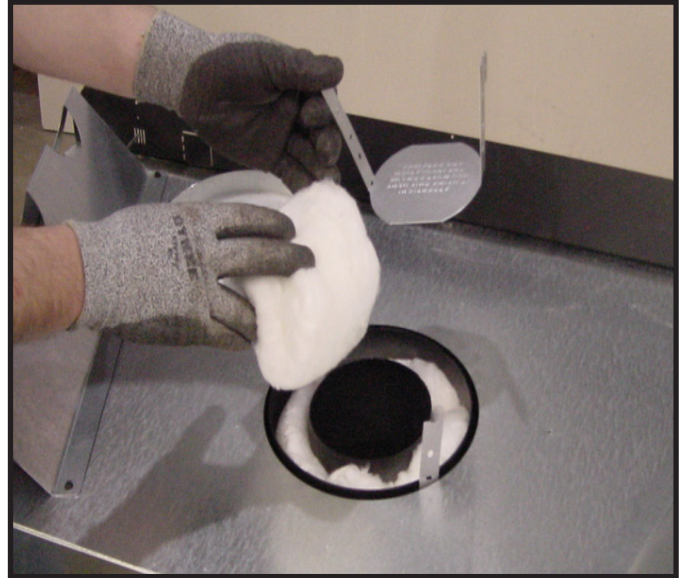

Figure 6.4 (Generic Appliance Shown) Remove the insulation basket and white insulation from the center vent pipe.

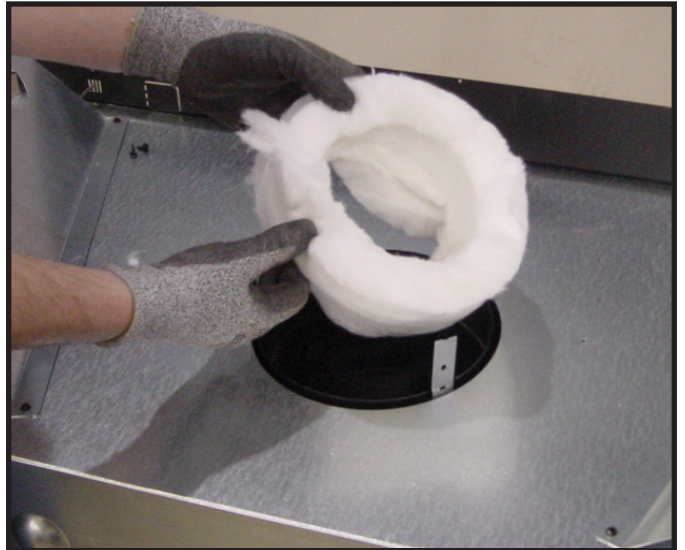

Figure 6.5 (Generic Appliance Shown) Remove the insulation from the outer vent pipe. For rear venting there is no insulation in the outer vent pipe.

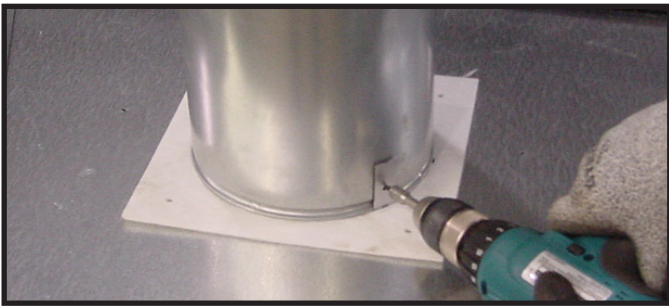

Figure 6.6 (Generic Appliance Shown) To attach the first section of vent pipe, make sure to use the fiberglass gasket in the manual bag to seal between the first vent component and the outer fireplace wrap. Caulk with a minimum of 300 °F continuous exposure rating may be used to hold the part in place.

Secure the first section of venting to the fireplace by screwing through the two straps left over from cutting the seal cap strap in step 2.

Rear Vent

NOTICE: Once appliance is set up for top or rear venting, it CANNOT be changed at a later time.



Figure 6.7 (Generic Appliance Shown) Fold the tabs toward the center of the seal cap (90°) and remove the insulation gasket.



Figure 6.8 (Generic Appliance Shown) Cut the metal retaining band and fold the sides out.



Figure 6.9 (Generic Appliance Shown) Fold the center parts of the retaining band out and use to remove the seal cap.

NOTICE: Once the seal cap has been removed it CANNOT be reattached.



Figure 6.10 (Generic Appliance Shown) Discard the vent cap, remove and discard the insulation basket.

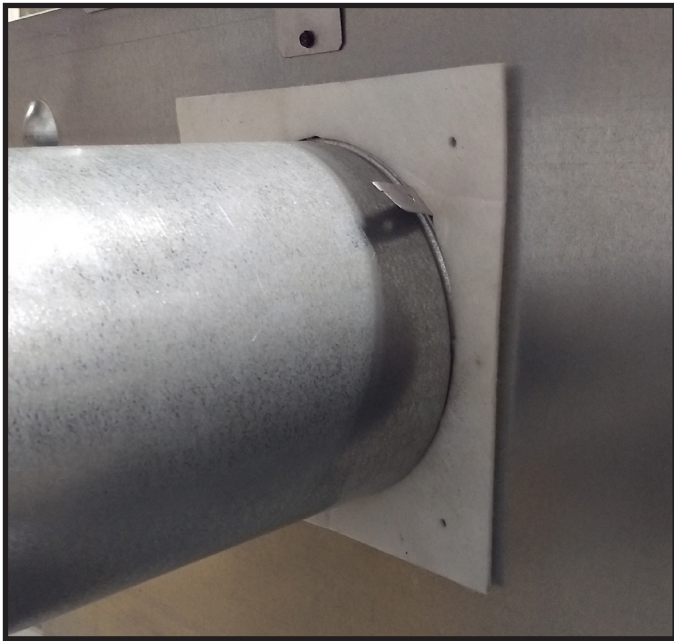

Figure 6.11 Attach the first vent section (it will snap into place). Slide the insulation gasket onto the vent section, up against the appliance and over the tabs.

B. Installing Optional Heat-Zone®-240V

- Remove the knockout from the fireplace and discard it. See Figure 6.12.
- Center the duct collar around the exposed hole and attach it to the fireplace with 3 screws. Note: Do this BEFORE final positioning of fireplace.
- Determine the location for the air register/fan housing assembly.

Reference the appropriate instructions included with the kit for the remaining installation steps.

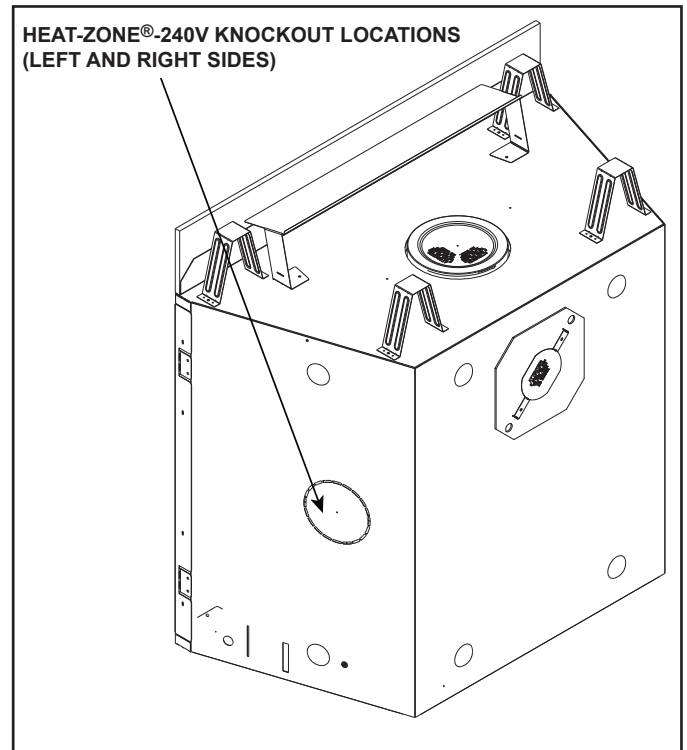

Figure 6.12 Heat-Zone®-240V Knockout Locations

C. Securing and Leveling the Appliance

WARNING! Risk of Fire! Prevent contact with:

- Sagging or loose insulation
- Insulation backing or plastic
- Framing and other combustible materials

Block openings into the chase to prevent entry of blown-in insulation. Make sure insulation and other materials are secured.

DO NOT notch the framing around the appliance standoffs.

Failure to maintain air space clearance could cause overheating and fire.

The diagram shows how to properly square and position, and secure the appliance. See Figures 6.13 and 6.14. Nailing tabs are provided to secure the appliance to the framing members.

- Bend out nailing tabs on each side.
- Place the appliance into position.
- Keep nailing tabs flush with the framing.
- Level the appliance from side to side and front to back.
- “Square” the unit by securing diagonal dimensions to within 1/4 in. (6 mm) of each other. See Figure 6.13.
- Shim the appliance as necessary. It is acceptable to use wood shims underneath the appliance.
- Secure the appliance to the framing by using nails or screws through the nailing tabs.
- Optional: Secure the appliance to the floor by inserting two screws through the pilot holes at the bottom of the appliance.

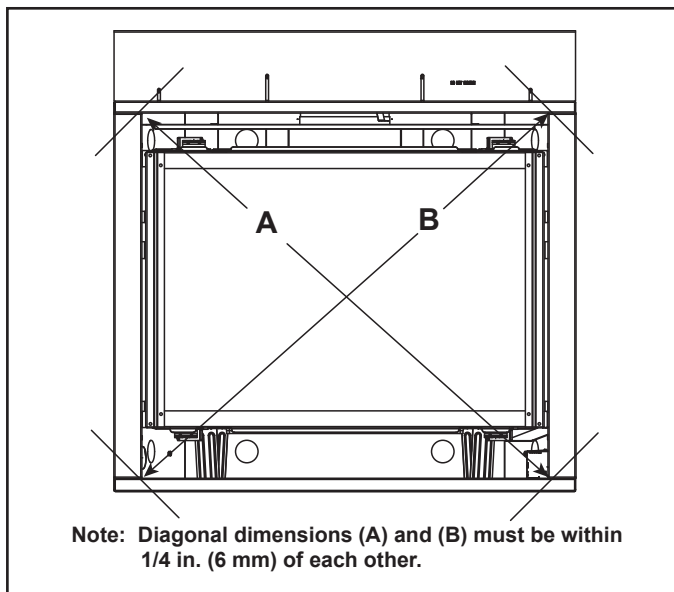

Figure 6.13 Positioning the Appliance Squarely

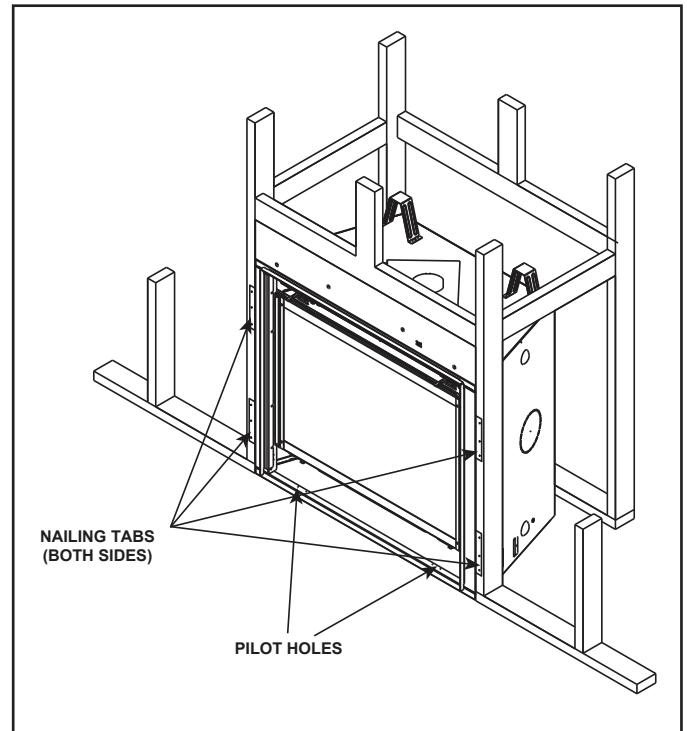

Figure 6.14 Proper Positioning and Securing of an Appliance

D. Installing the Non-combustible Board

The factory supplied non-combustible board spans the distance from the top of the fireplace to the center of the framing header. This board must be used. See Figure 6.15.

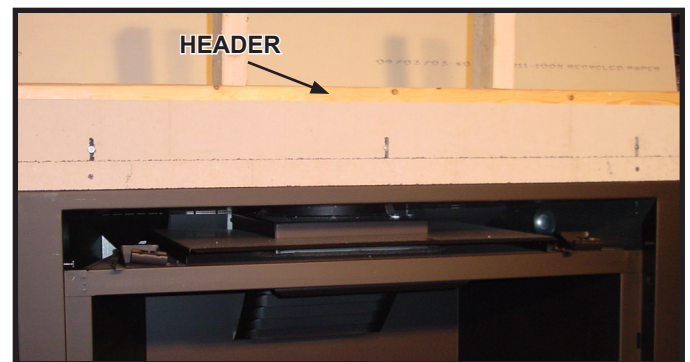

Figure 6.15 Non-combustible Board

7 Venting and Chimneys

A. Assemble Vent Sections

(DVP Pipe Only)

Attach Vent to the Firebox Assembly

Note: The end of the pipe sections with the lanced tabs will face toward the appliance.

Attach the first pipe section to the starting collar:

- Lanced pipe end of the starting collar.
- Inner pipe over inner collar.
- Push the pipe section until all lanced tabs snap in place.
- Lightly tug on pipe to confirm it has locked.

Required Commercial, Multi-family (Multi-level exceeding two stories), or High-Rise Applications

All outer pipe joints must be sealed with 100% silicone (300° F minimum continuous exposure rating), including the slip section that connects directly to the horizontal termination cap.

- Apply a bead of silicone sealant (300 °F (149 °C) minimum continuous exposure rating) inside the female outer pipe joint prior to joining sections. See Figure 7.1. **OR**

Apply a bead of silicone sealant (300 °F (149 °C) minimum continuous exposure rating) to the outside of connecting joint after joining sections **OR**

Apply aluminum foil tape (300 °F (149 °C) minimum continuous exposure rating) to the outside of connecting joint after joining sections. On horizontal pipe runs, it is recommended that the tape seam is positioned on the bottom side of the vent pipe.

- Only outer pipes need to be sealed. All unit collar, pipe, slip section, elbow and cap outer flues shall be sealed in this manner, unless otherwise stated.

WARNING! Risk of Fire or Explosion! DO NOT break silicone seals on slip sections. Use care when removing termination cap from slip pipe. If slip section seals are broken during removal of the termination cap, vent could leak.

Assemble Pipe Sections

Per Figure 7.2:

- Start the inner pipe on the lanced end of section A into the flared end of section B.
 - Start the outer pipe of section A over the outer pipe of section B.
 - Once both vents sections are started, push firmly until all lanced tabs lock into place.
 - Lightly tug on the pipe to confirm the tabs have locked.
- It is acceptable to use screws no longer than 1/2 in. (13 mm) to hold outer pipe sections together. If predrilling holes, **DO NOT** penetrate inner pipe.

For 90° and 45° elbows that are changing the vent direction from horizontal to vertical, one screw minimum should be put in the outer flue at the horizontal elbow joint to prevent the elbow from rotating. Use screws no longer than 1/2 in. (13 mm). If predrilling screw holes, **DO NOT** penetrate inner pipe.



Figure 7.1 High Temperature Silicone Sealant

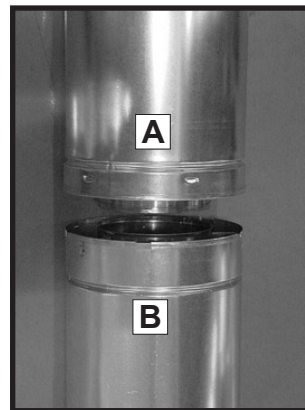

Figure 7.2

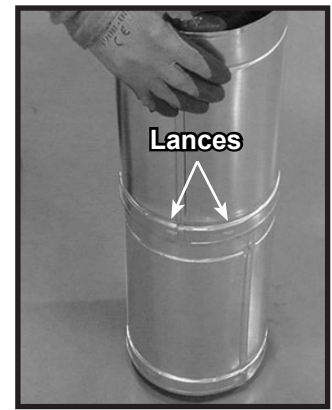

Figure 7.3

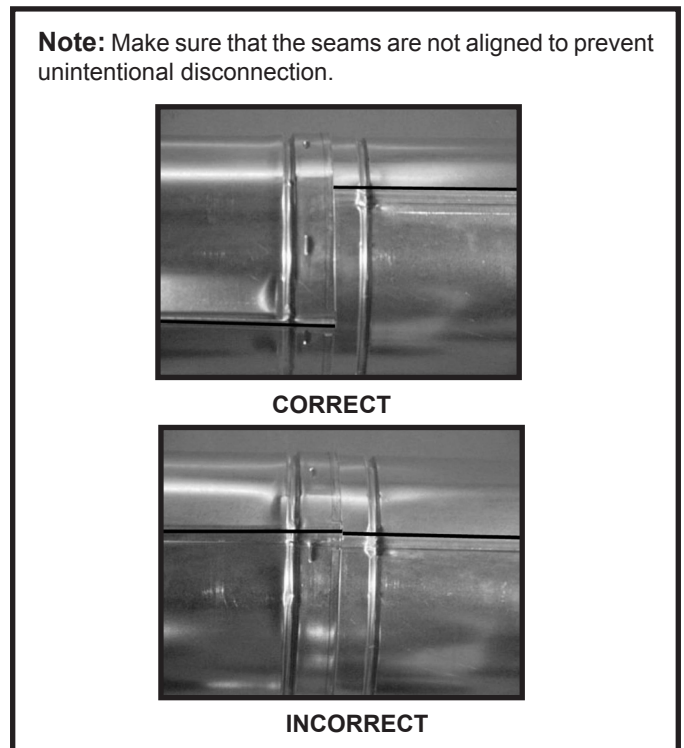

Figure 7.4 Seams

B. Secure the Vent Sections

- Vertical runs originating off the top of the appliance, with no offsets, must be supported every 8 ft. (2.44 m) after the maximum allowed 25 ft. (7.62 m) of unsupported rise.
- Vertical runs originating off the rear of the appliance, or after any elbow, must be supported every 8 ft. (2.44 m).
- Horizontal runs must be supported every 5 feet (1.52 m).
- Vent supports or plumbers strap (spaced 120° apart) may be used to support vent sections. See Figures 7.5 and 7.6.
- Wall shield firestops may be used to provide horizontal support to vent sections.

WARNING! Risk of Fire, Explosion or Asphyxiation! Improper support could allow vent to sag and separate. Use vent run supports and connect vent sections per installation instructions. **DO NOT** allow vent to sag below connection point to appliance.

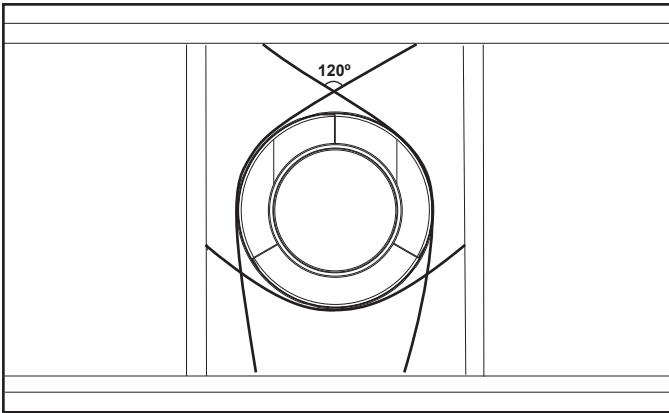

Figure 7.5 Securing Vertical Pipe Sections

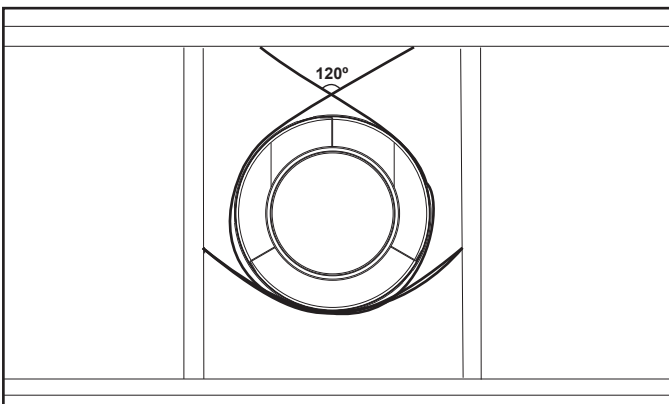

Figure 7.6 Securing Horizontal Pipe Sections

C. Disassemble Vent Sections

- Rotate either section (see Figure 7.7) so the seams on both pipe sections are aligned as shown in Figure 7.8.
- Pull carefully to separate the pieces of pipe.

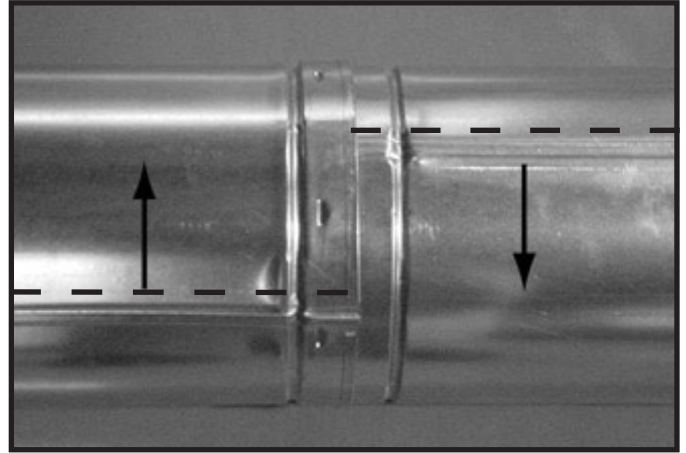

Figure 7.7 Rotate Seams for Disassembly

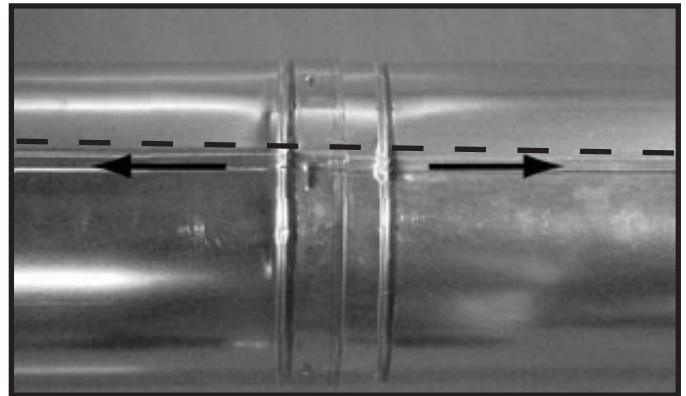

Figure 7.8 Align and Disassemble Vent Sections

D. Vertical Termination Requirements

Install Metal Roof Flashing

- See minimum vent heights for various pitched roofs (Figure 7.9) to determine the length of pipe to extend through the roof.
- Slide the roof flashing over the pipe sections extending through the roof as shown in Figure 7.10.

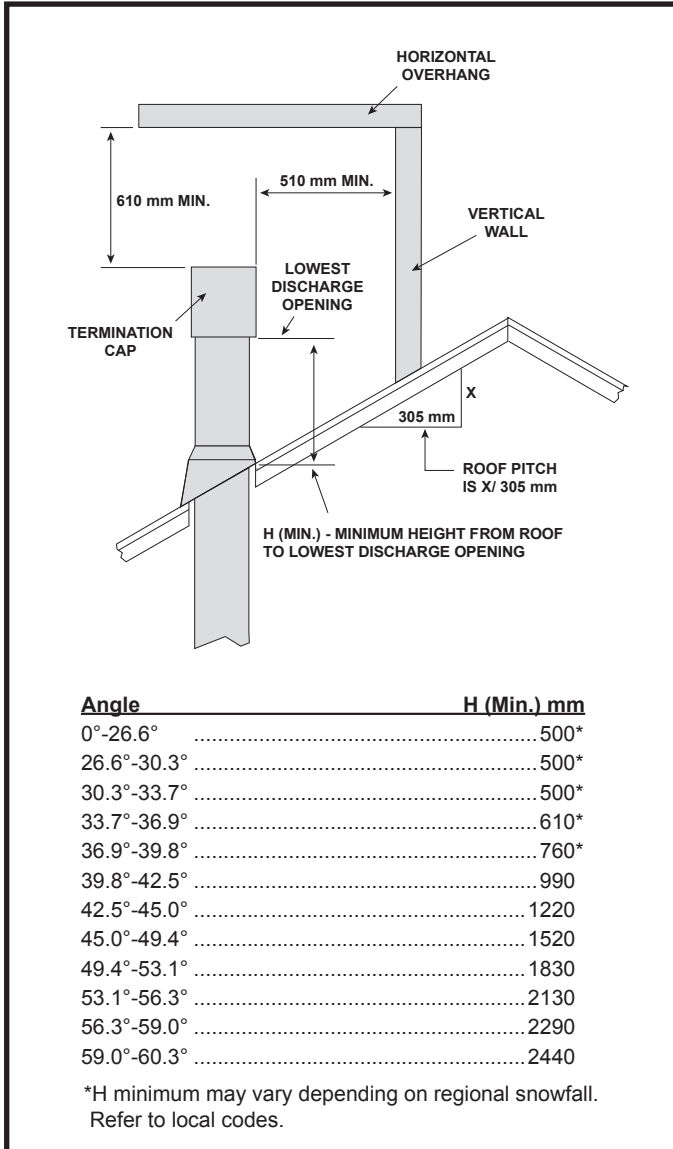

Figure 7.9 Minimum Height From Roof to Lowest Discharge Opening

NOTICE: Failure to properly caulk the roof flashing and pipe seams could permit entry of water.

- Caulk the gap between the roof flashing and the outside diameter of the pipe.
- Caulk the perimeter of the flashing where it contacts the roof surface. See Figure 7.10.
- Caulk the overlap seam of any exposed pipe sections that are located above the roof line.

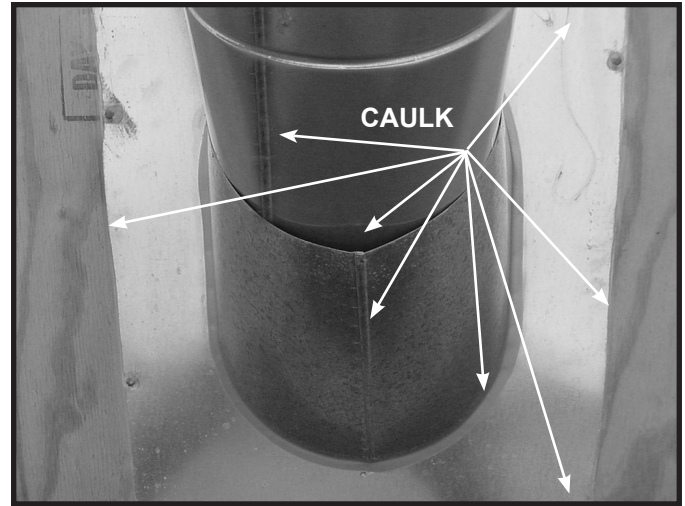

Figure 7.10

Assemble and Install Storm Collar

CAUTION! Risk of Cuts, Abrasions or Flying Debris. Wear protective gloves and safety glasses during installation. Sheet metal edges are sharp.

- Slide the storm collar onto the exposed pipe section and align brackets.
- Insert a bolt (provided) through the brackets and install nut. Do not completely tighten.



Figure 7.11 insert Bolt into Brackets

- Slide the assembled storm collar down the pipe section until it rests on the roof flashing (see Figure 7.11).
- Tighten nut and make sure the collar is tight against the pipe section.
- Caulk around the top of the storm collar. See Figure 7.12.

Install Vertical Termination Cap

- Attach the vertical termination cap by sliding the inner collar of the cap into the inner flue of the pipe section while placing the outer collar of the cap over the outer flue of the pipe section.
- Secure the cap by driving three self-tapping screws (supplied) through the pilot holes in the outer collar of the cap into the outer flue of the pipe (see Figure 7.12).

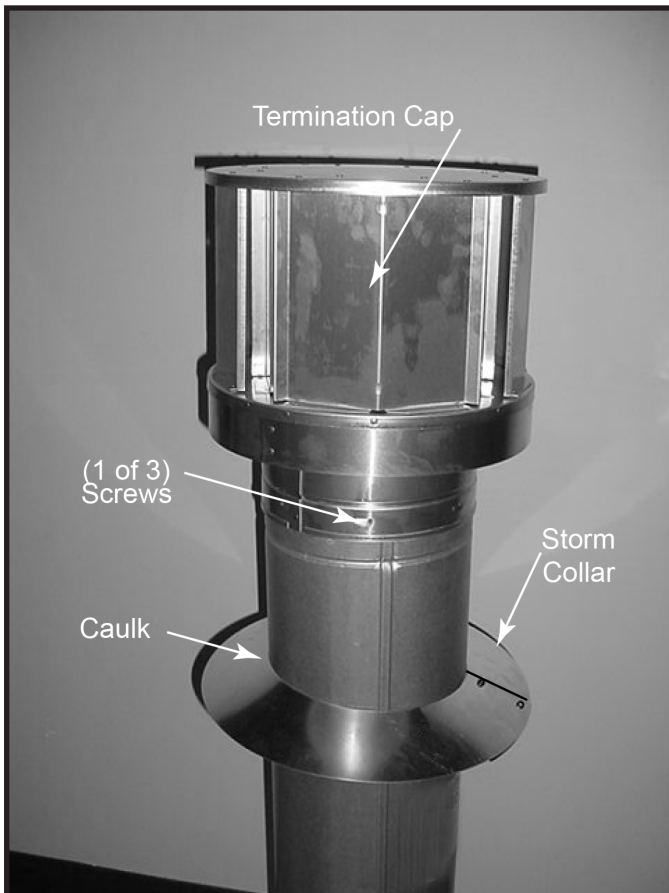

Figure 7.12

E. Horizontal Termination Requirements

Heat Shield Requirements for Horizontal Termination

WARNING! Risk of Fire! To prevent overheating and fire, heat shields must extend through the entire wall thickness.

- **DO NOT** remove the heat shields attached to the wall shield firestop and the horizontal termination cap (shown in Figure 7.13).
- Heat shields must overlap 1-1/2 in. (38 mm) minimum.

There are two sections of the heat shield. One section is factory-attached to the wall shield firestop. The other section is factory-attached to the cap. See Figure 7.16.

If the wall thickness does not allow the required 1-1/2 in. (38 mm) heat shield overlap when installed, an extended heat shield must be used.

- If the wall thickness is less than 4 in. (102 mm) (DVP), the heat shields on the cap and wall shield firestop must be trimmed. A minimum 1-1/2 in. (38 mm) overlap **MUST** be maintained.
- Use an extended heat shield if the finished wall thickness is greater than 7-1/4 in. (184 mm).
- The extended heat shield may need to be cut to length maintaining sufficient length for a 1-1/2 in. (38 mm) overlap between heat shields.
- Attach the extended heat shield to either of the existing heat shields using the screws supplied with the extended heat shield. Refer to vent components diagrams in the back of this manual.
- Rest the small leg on the extended heat shield on top of the pipe section to properly space it from the pipe section.

Important Notice: Heat shields may not be field constructed.

Install Horizontal Termination Cap

WARNING! Risk of Fire! The telescoping flue section of the termination cap **MUST** be used when connecting vent.

- 1-1/2 (38 mm) minimum overlap of flue telescoping section is required.

Failure to maintain overlap could cause overheating and fire.

- Vent termination must not be recessed in the wall. Siding may be brought to the edge of the cap base.
- Flash and seal as appropriate for siding material at outside edges of cap.

CAUTION! Risk of Burns! Local codes may require installation of a cap shield to prevent anything or anyone from touching the hot cap.

NOTICE: For certain exposures which require superior resistance to wind-driven rain penetration, a flashing kit and HRC caps are available. When penetrating a brick wall, a brick extension kit is available for framing the brick.

Note: When using termination caps with factory-supplied heat shield attached, no additional wall shield firestop is required on the exterior side of a combustible wall.

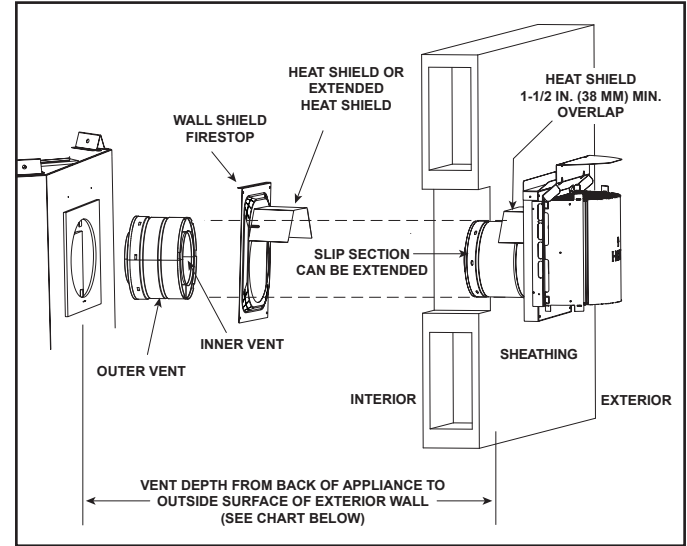

Figure 7.13 Venting Through the Wall - Generic Fireplace Shown

Termination Cap Specification Chart
(depth without using additional pipe sections)

	DVP-TRAPK1	DVP-TRAP1	DVP-TRAPK2	DVP-TRAP2
	Top Vent Depth	Rear Vent Depth	Top Vent Depth	Rear Vent Depth
6X-AU	N/A	3-1/8 in. to 5 in. (79 mm to 127 mm)	N/A	5-1/2 in. to 9-1/2 in. (140 mm to 241 mm)
	DVP-HPC1	DVP-HPC1	DVP-HPC2	DVP-HPC2
	Top Vent Depth	Rear Vent Depth	Top Vent Depth	Rear Vent Depth
	N/A	3-1/8 in. to 5-1/4 in. (79 mm to 133 mm)	N/A	5-1/4 in. to 9-3/8 in. (133 mm to 238 mm)

DVP-TRAP1 can adjust 1-1/2 in. (3-1/8 to 4-5/8)
38 mm (79 mm to 117 mm)

DVP-TRAP2 can adjust 4 in. (5-3/8 to 9-3/8)
102 mm (137 mm to 238 mm)

DVP-HPC1 can adjust 2-1/8 in. (4-1/4 to 6-3/8)
54 mm (108 mm to 162 mm)

DVP-HPC2 can adjust 4-1/8 in. (6-3/8 to 10-1/2)
105 mm (162 mm to 267 mm)

Wind Diverter Installation

If installed in a windy environment (over 50KPH), with a SLP-TRAP, SLP-TRAP2, or DVP-TRAP2, horizontal termination cap, the provided wind diverter may be bent and installed as show in Figures 7.14 and 7.15.

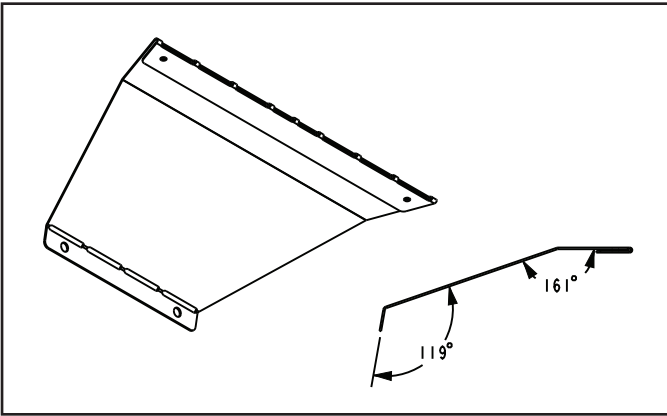

Figure 7.14 Wind Diverter



Figure 7.15 Wind Diverter Installed

8 Electrical Information

A. General Information

WARNING! Risk of Shock or Explosion! DO NOT wire 220/240 VAC to the valve or to the appliance wall switch. Incorrect wiring will damage controls.

- Wire the appliance junction cord to unswitched 220/240 VAC. This is required for proper operation of the appliance.
- A 220/240 VAC circuit for this product must be protected with ground-fault circuit-interrupter protection, in compliance with the applicable electrical codes, when it is installed in locations such as in bathrooms or near sinks.
- Low voltage and 220/240 VAC voltage cannot be shared within the same wall box.

Electrical Service and Repair

WARNING! Risk of Shock! Label all wires prior to disconnection when servicing controls. Wiring errors can cause improper and dangerous operation. Verify proper operation after servicing.

WARNING! Risk of Shock! Replace damaged wire with type 105 °C rated wire. Wire must have high temperature insulation.

Accessories Requirements

- This appliance may be used with a wall switch, wall mounted thermostat and/or a remote control.

Wiring for optional Hearth & Home Technologies approved accessories should be done now to avoid reconstruction. Follow instructions that come with those accessories.

B. Wiring Requirements

IntelliFire™ Plus Ignition System Wiring

- Wire the appliance junction cord to 220/240 VAC for proper operation of the appliance.

WARNING! Risk of Shock or Explosion! DO NOT wire IPI controlled appliance junction cord to a switched circuit. Incorrect wiring will override IPI safety lockout.

- Refer to Figure 8.3, IPI Wiring Diagram.
- This appliance is equipped with an IntelliFire™ Plus control valve which operates on a 6 volt/1.5 AMP system.
- Plug the 6 volt transformer plug into the appliance junction cord to supply power to the unit OR install 4 AA cell batteries (not included) into the battery pack before use.

NOTICE: Batteries should only be used as a power source in the event of an emergency power outage. Batteries should not be used as a primary long-term power source. Battery polarity must be correct when installing batteries. When using batteries as a power source, the 6-volt transformer must be unplugged from the receptacle.

Do not store batteries in the battery pack when the appliance is powered by the 6 volt transformer connected to permanent electrical service.

Accessories Requirements

- This appliance ships standard with a remote control.

Wiring for optional Hearth & Home Technologies approved accessories should be done now to avoid reconstruction. Follow instructions that come with those accessories.

The junction cord, control module, LED power supply and wall switch receiver can be accessed by removing the vanity panel and component heat shield. The decorative front must be removed to access these components. See Figure 8.3.

CAUTION! Risk of Overheating! Component heat shield MUST be installed before operating appliance. Electrical components will be damaged.

CAUTION! Risk of Overheating! DO NOT remove component insulation from top of component heat shield. Electrical components will be damaged.

Note: When using PVLP-SLP-AU power vent, see PVLP-SLP-AU instructions for additional wiring requirements.

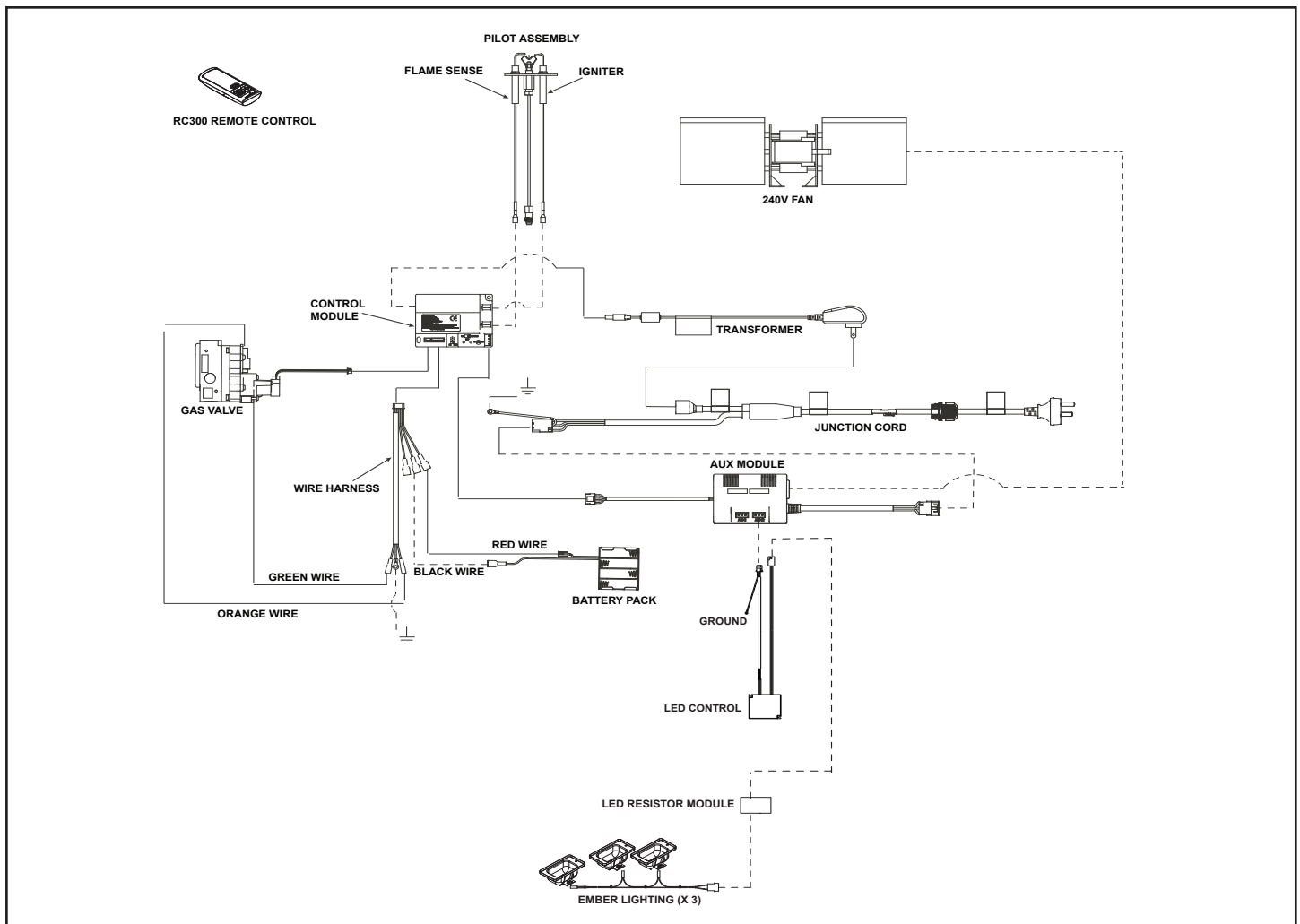

Figure 8.3 IntelliFire™ Plus Wiring Diagram with Remote

9 Gas Information

A. Fuel Conversion

- Make sure the appliance is compatible with available gas types.
- Conversions must be made by a qualified service technician using Hearth & Home Technologies specified and approved parts.

B. Gas Pressure

WARNING! Risk of Explosion! An in-line regulator **MUST** be installed if the gas pressure exceeds 3.4 kPa. Failure to install a regulator could damage valve.

Pressure requirements for 6X-AU fireplaces are shown in the table below.

Two taps are provided on the right hand side of the gas control for a test gauge connection to measure the inlet and outlet pressures.

The fireplace and its individual shut-off valve must be disconnected from the gas supply piping system during any pressure testing of the system at test pressures in excess of 6 kPa.

If the fireplace must be isolated from the gas supply piping system by closing an individual shut-off valve, it must be of the handle-less type.

- Optimum appliance performance requires proper input pressures.
- Pressure requirements are:

Gas Pressure	Natural Gas	Propane	ULPG
Minimum inlet pressure	1.13 KPa	2.75 KPa	2.75 KPa
Maximum inlet pressure	3.40 KPa	3.40 KPa	3.40 KPa
Manifold pressure	.87 KPa	2.49 KPa	2.49 KPa

WARNING! Risk of Fire or Explosion! High pressure will damage valve. Low pressure could cause explosion.

- Verify inlet pressures. Verify minimum pressures when other household gas appliances are operating.
- Install regulator upstream of valve if line pressure is greater than 3.40 KPa.

⚠ WARNING



Fire Risk.
Explosion Hazard.
High pressure will damage valve.

- Disconnect gas supply piping **BEFORE** pressure testing gas line at test pressures above 3.40 KPa (1/2 psig).
- Close the manual shutoff valve **BEFORE** pressure testing gas line at test pressures equal to or less than 3.40 KPa (1/2 psig).

C. Gas Service Access

Note: This appliance does include a manual gas shutoff valve that is located in the valve compartment. This manual gas shutoff valve is accessible for service by removing the decorative front. The valve is most accessible if it is located forward in the control cavity of the appliance.

Depending upon local code, an additional manual gas shutoff, in a readily accessible area may be required and located upstream from the appliance.

D. Gas Connection

Note: Have the gas supply line installed in accordance with local building codes by a qualified installer approved and/or licensed as required by the locality.

Note: Before the first firing of the appliance, the gas supply line should be purged of any trapped air.

Note: Consult local building regulations to properly size the gas supply line leading to the (Rp 1/2 in.) hook-up at the unit.

Incoming gas line should be piped into the valve compartment and connected to the ISO 7-Rp 1/2 (BSP Rp 1/2) threaded gas inlet connection on the manual shutoff valve.

IMPORTANT NOTICE: (Items 1, 2 and 3 applies to ALL Heat & Glo gas appliances)

1. **1/2 in. GAS LINE:** Run through cavity 70 mm above finished hearth level, **NOT RIGID, NOT CLIPPED**, with minimum 500 mm into cavity and 120 mm back from plaster face.
2. **PVC (COMPOSITE) GASLINE** must terminate minimum 500 mm short of gas heater. Copper pipe **MUST** be the final connection to the gas heater.
3. **ISOLATING SWITCH:** Location within 1 metre of fireplace, subject to mantelpiece etc. Check to ensure it remains clear of any mantelpiece installation.

Leak test all gas line points and the gas control valve prior to and after starting the gas appliance.

E. High Altitude Installations

NOTICE: If the heating value of the gas has been reduced, these rules do not apply. Check with your local gas utility or authorities having jurisdiction.

When installing above 2000 ft. (610 m) elevation:

Reduce input rate 4% for each 1000 ft. (305 m) above 2000 ft. (610 m).

F. Air Shutter Setting

Air shutter settings should be adjusted by a qualified service technician at the time of installation. The air shutter is set at the factory for minimum vertical vent run. Adjust air shutter for longer vertical runs. See Figure 9.1.

- Loosen the wing nut.
- Move the air handle to the left to open the air shutter.
- Move the air handle to the right to close the air shutter.
- Tighten the wing nut.

NOTICE: If sooting occurs, provide more air by opening the air shutter.

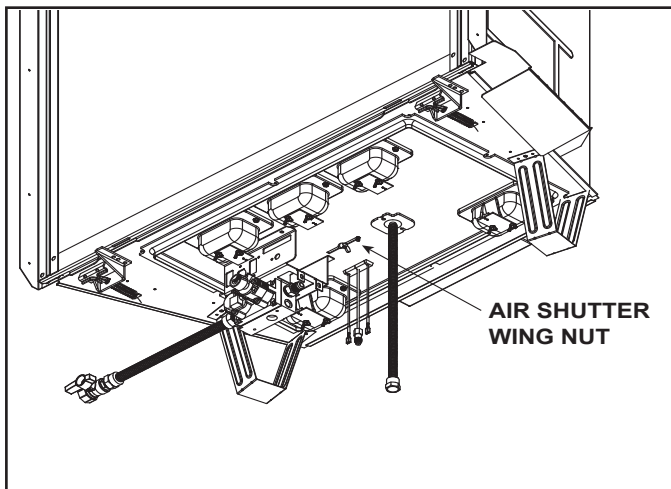

Figure 9.1 Air Shutter

Air Shutter Settings

	NG	LP	ULPG
6X-AU	5/8 in. (16 mm)	Fully Open	Fully Open

10 Finishing

A. Facing Material

- Metal front faces may be covered with non-combustible materials only.
- Facing and/or finishing materials must not interfere with air flow through louvers, operation of louvers or doors, or access for service.
- Facing and/or finishing materials must never overhang into the glass opening.
- Observe all clearances when applying combustible materials.
- Seal joints between the finished wall and appliance top and sides using a 300 °F (149 °F) minimum sealant. Refer to Figure 10.1.

WARNING! Risk of Fire! DO NOT apply combustible materials beyond the minimum clearances. Comply with all minimum clearances to combustibles as specified in this manual. Overlapping materials could ignite and will interfere with proper operation of doors and louvers.

NOTICE: Surface temperatures around the appliance will become warm while the appliance is in operation. Ensure finishing materials used for all surfaces (floor, walls, mantels, etc.) will withstand temperatures up to 190 °F (88 °C). If using vinyl flooring, refer to Section 3.D.

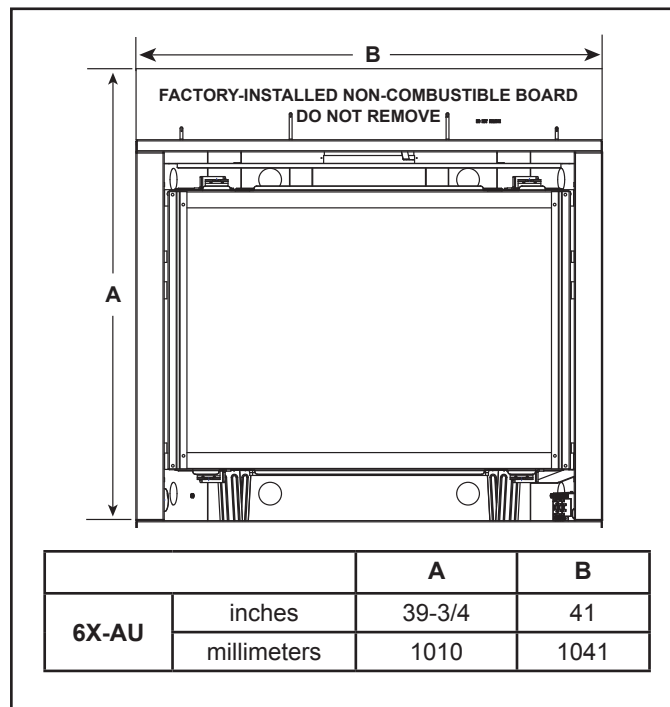

Figure 10.2 Noncombustible Facing Diagram

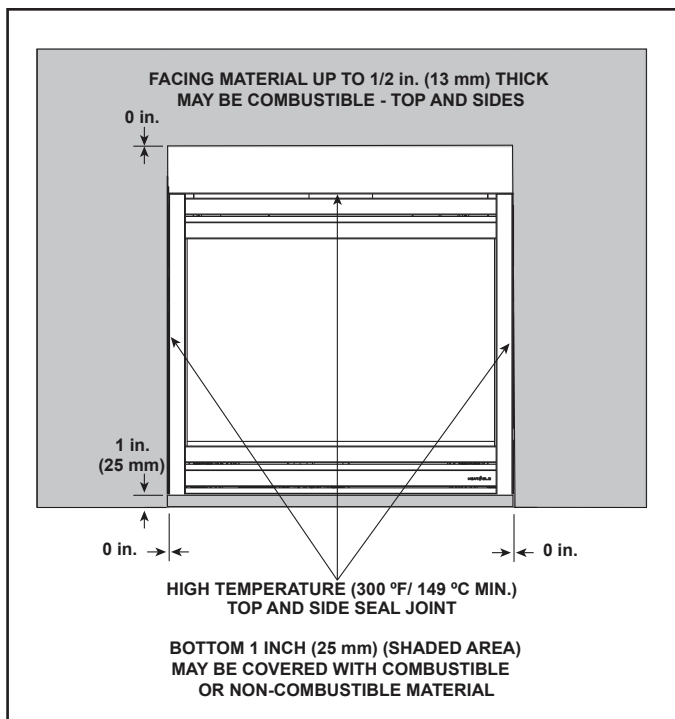

Figure 10.1 Facing Materials

B. Mantel and Wall Projections

WARNING! Risk of Fire! Comply with all minimum clearances as specified. Framing closer than the minimums listed must be constructed entirely of noncombustible materials (i.e., steel studs, concrete board, etc.)

Mantels - Combustible or Painted Surfaces

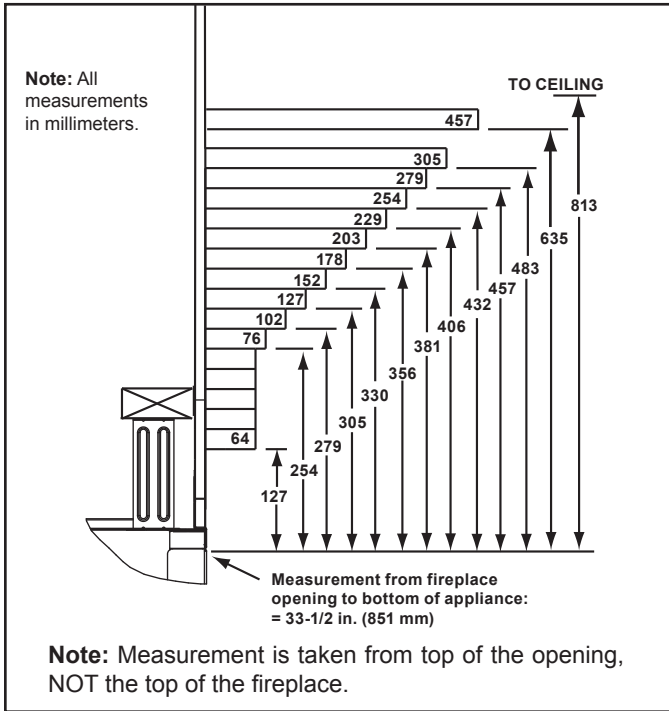

Figure 10.3 Minimum Vertical and Maximum Horizontal Dimensions - Combustible or Painted Surfaces

Mantel Legs or Wall Projections

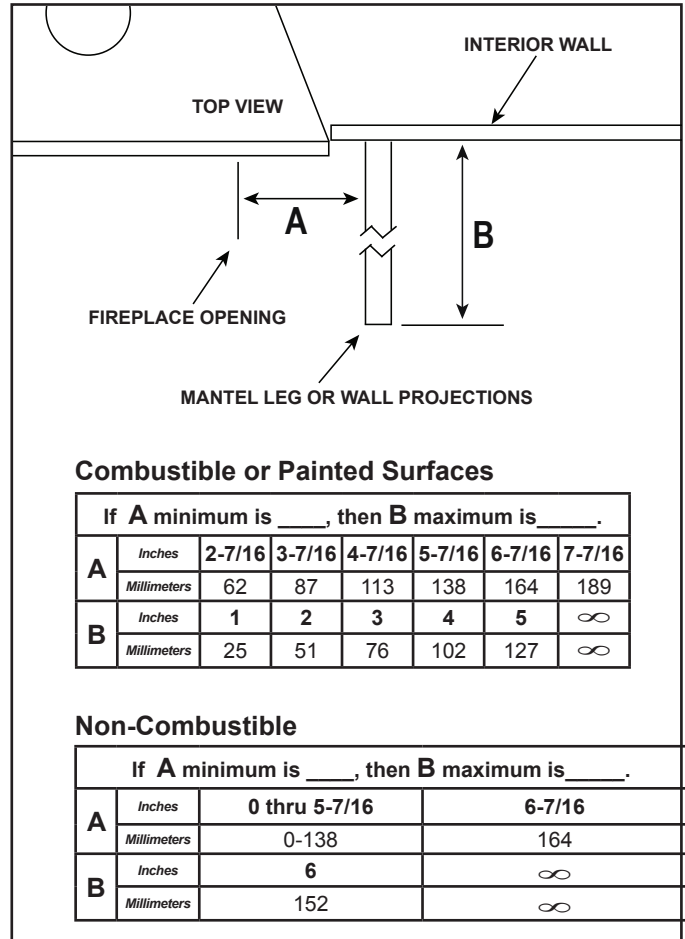

Figure 10.5 Clearances to Mantel Leg or Wall Projections (Acceptable on both sides of opening)

Mantels - Non-Combustible

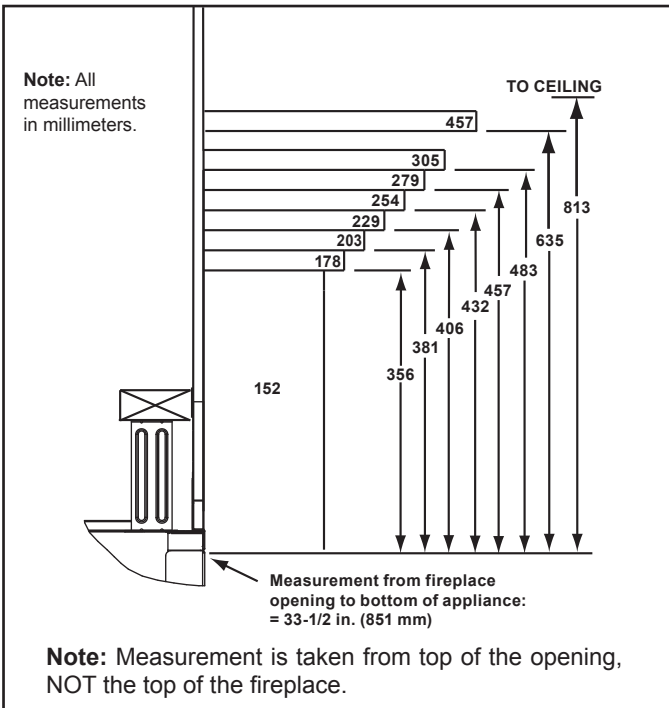

Figure 10.4 Minimum Vertical and Maximum Horizontal Dimensions - Non-Combustible

C. Decorative Fronts

Only decorative fronts certified for use with this appliance model may be used. Contact your dealer for a list of decorative fronts that may be used. Once you have determined what kind of decorative front and finishing material is going to be used on the fireplace, you may use the table below which shows the decorative front models and the finishing material thickness allowed.

THE GUARD IS FITTED TO THIS APPLIANCE TO REDUCE THE RISK OF FIRE OR INJURY FROM BURNS AND NO PART OF IT SHOULD PERMANENTLY BE REMOVED. FOR PROTECTION OF YOUNG CHILDREN OR THE INFIRM, A SECONDARY GUARD IS REQUIRED.

Note: Finishing strips may be used to aid in positioning of non-combustible facing materials for some of the facing and decorative front combinations specified in the table below. They must be removed following finishing work. These can be ordered from your local dealer.

DECORATIVE FRONT	FIT	FINISH MATERIAL THICKNESS	SEE FIGURE
CF	Inside	Any	10.8
FS	Overlap	1 in. (25 mm) or less	10.6
	Inside Fit	Greater than 1 in. (25 mm)	10.7

Finishing Material: 1 Inch (25 mm) Thick or Less

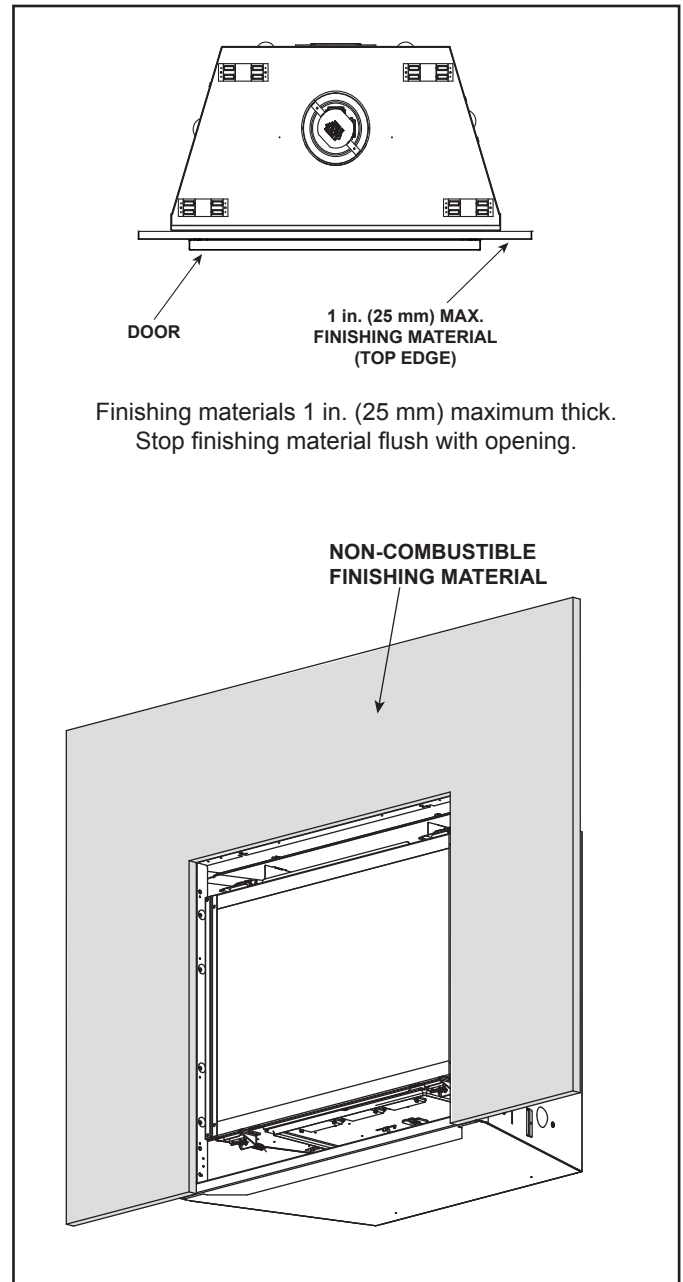

Figure 10.6 Finishing Material 1 In. (25 mm) Thick or Less

**Finishing Material Thickness:
1-6 inches (25-152 mm) maximum**

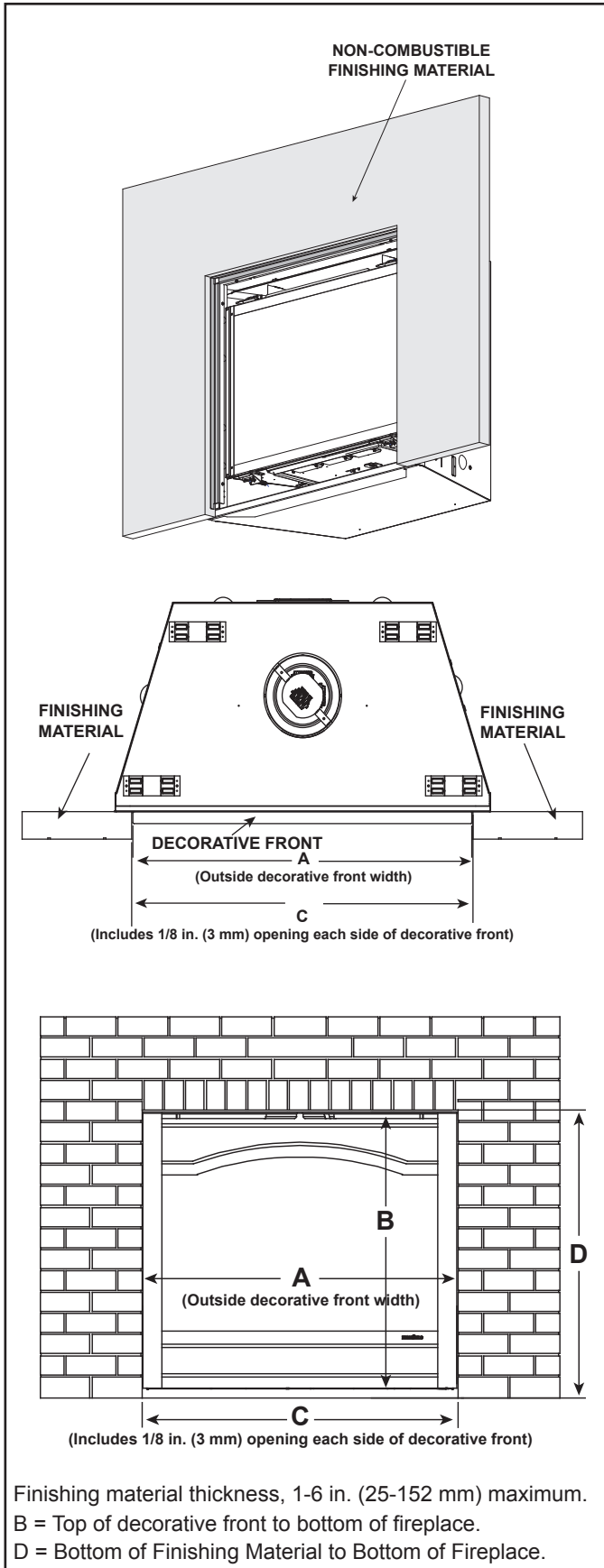

Figure 10.7 Finishing Material Thickness Greater Than 1 in. (25 mm)

**Finishing Material Thickness:
0-6 inches (0-152 mm) maximum**

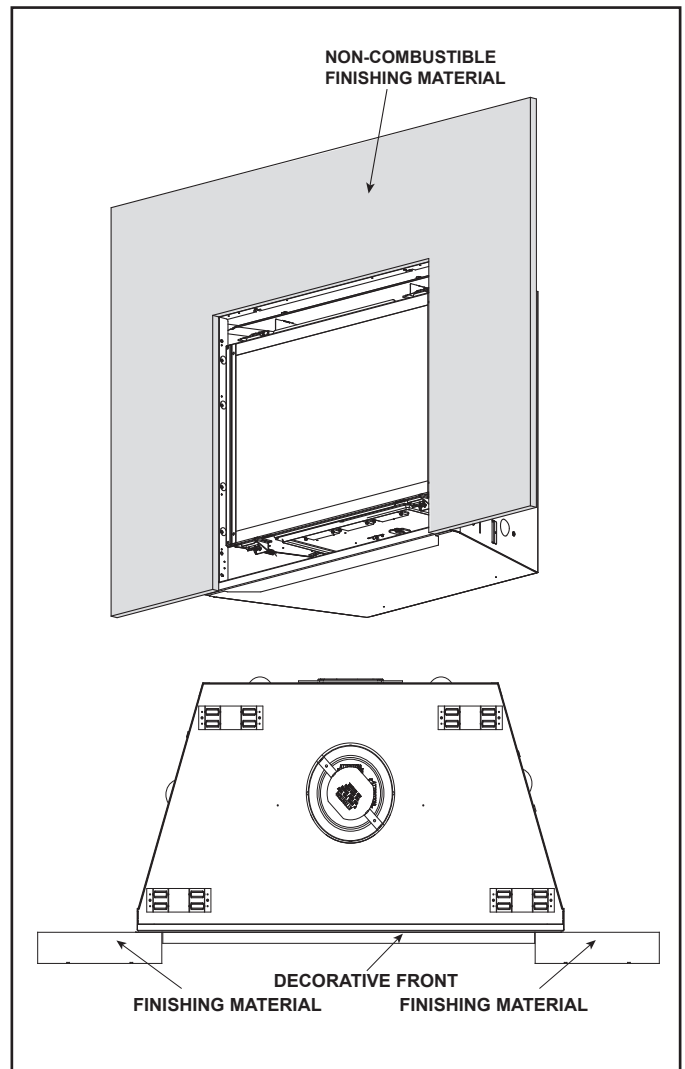

Figure 10.8 CF Inside Fit

	6X-AU	
	Inches	Millimeters
A	37-1/16	941
B	34-1/16	865
C	37-5/16	948
D	34-7/16	875

11 Appliance Setup

A. Remove Fixed Glass Assembly

WARNING! Risk of Asphyxiation! Handle fixed glass assembly with care. Inspect the gasket to ensure it is undamaged and inspect the glass for cracks, chips or scratches.

- **DO NOT** strike, slam or scratch glass.
- **DO NOT** operate fireplace with glass removed, cracked, broken or scratched.
- Replace as a complete assembly.

Removing Fixed Glass Assembly

- Pull the four glass assembly latches out of the groove on the glass frame. Remove glass door from the appliance. See Figure 11.1.

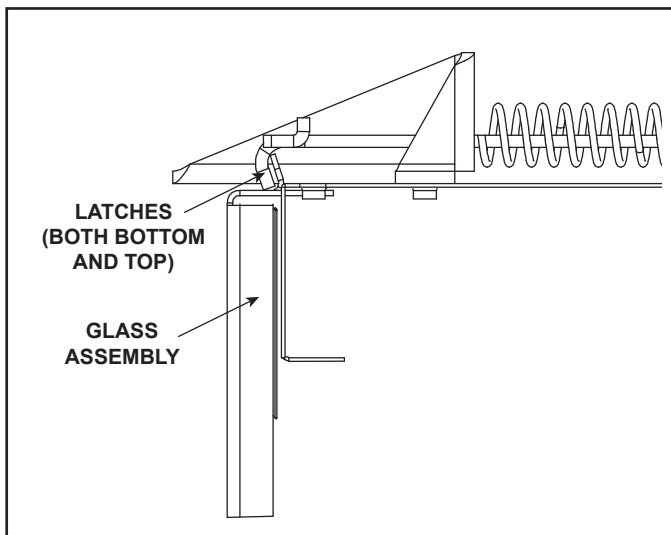

Figure 11.1 Fixed Glass Assembly

B. Remove the Shipping Materials

Remove shipping materials from inside or underneath the firebox.

- The splatter guard is a piece of corrugated material used to protect the appliance during the installation process before finishing work on the whole hearth is complete. Splatter guards may be factory installed or accompany the decorative front of the appliance, depending on the fireplace model. Splatter guards must be removed before appliance is fired.

WARNING! Risk of Fire! Close the ball valve before installing the splatter guard to prevent accidental lighting. Remove the splatter guard before lighting the appliance.

C. Clean the Appliance

Clean/vacuum any sawdust that may have accumulated inside the firebox or underneath in the control cavity.

D. Burner Top Installation

1. Bend the two tabs upward as shown in Figure 11.2
2. To install the fiber burner, mate the locating holes with the guide sleeves. Install fiber burner top so that it makes full contact with the underlying burner assembly.
3. Ensure that the ports in the steel burner are visible through the holes in the fiber burner top.

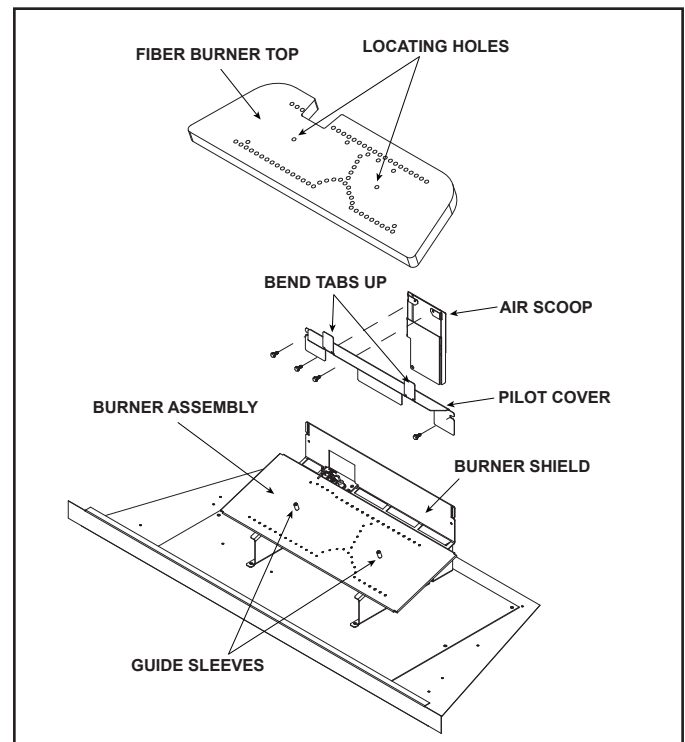

Figure 11.2

E. Install the Glass Refractory

CAUTION! Risk of Cuts, Abrasions or Flying Debris. Wear protective gloves and safety glasses during installation.

CAUTION! Glass Refractory is fragile. Handle with care.

1. Appliance is shipped with insulation board in place. Slide side pieces of insulation board towards the outside of the appliance about two inches (5 mm).
2. Install rear glass panel in front of insulation board on rear refractory bracket. Hold rear glass panel in place and slide one side insulation board into position back-towards rear glass panel as shown in Figure 11.3.



Figure 11.3 Install Rear Glass Panel

3. Install side glass panel in front of insulation board.
4. Install side refractory bracket between the insulation board and the side of the firebox. Secure with screw as shown in Figure 11.4.
5. Bend side refractory tab over glass panel. See Figure 11.4.
6. Slide other insulation board on opposite side towards rear glass panel and repeat steps 3-5 for other side.

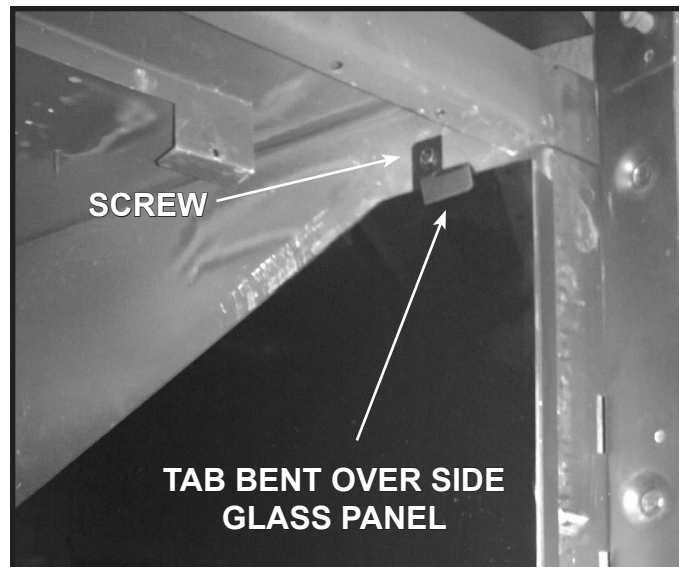

Figure 11.4 Install Side Glass Retention Bracket

7. Install top refractory panel. Rest it on top of the side glass panels and gently push to the rear. See Figure 11.5.



Figure 11.5 Install Top Refractory Panel

8. Set base refractory piece(s) in place as shown in Figure 11.6.



Figure 11.6 Install Base Refractory

F. Ember Placement

WARNING! Risk of Explosion! Follow ember placement instructions in manual. DO NOT completely block burner ports with ember material. Replace ember material annually. Improperly placed embers interfere with proper burner operation.

Ember material is shipped with this gas appliance. To place the ember material:

- Embers CANNOT completely block burner ports. Care should be taken not to block the lighting trail of ports.
- Embers may only be placed in areas as shown in Figure 11.7 and Figure 11.8 (LP & ULPG Only).
- **LP & ULPG Only:** Using dime-size pieces of Glowing Embers®, overlap the burner ports as shown in Figure 11.9. The impingement created by the embers will help blend the fire.
- Save the remaining ember materials for use during appliance servicing. The embers provided should be enough for 3 to 5 applications.

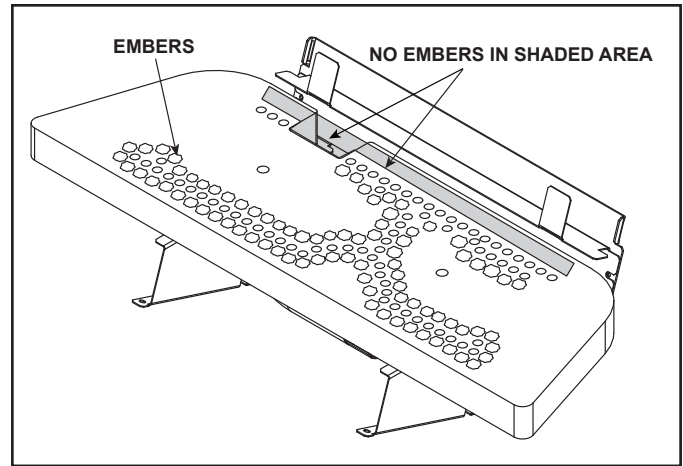

Figure 11.7 Placement of Embers (NG ONLY)

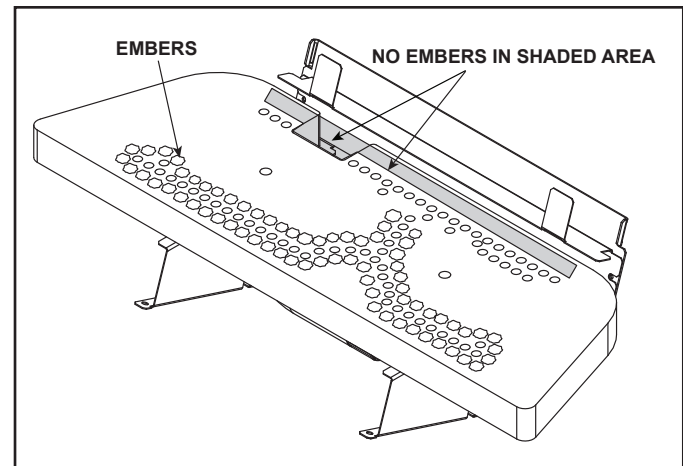

Figure 11.8 Placement of Embers (LP & ULPG Only)

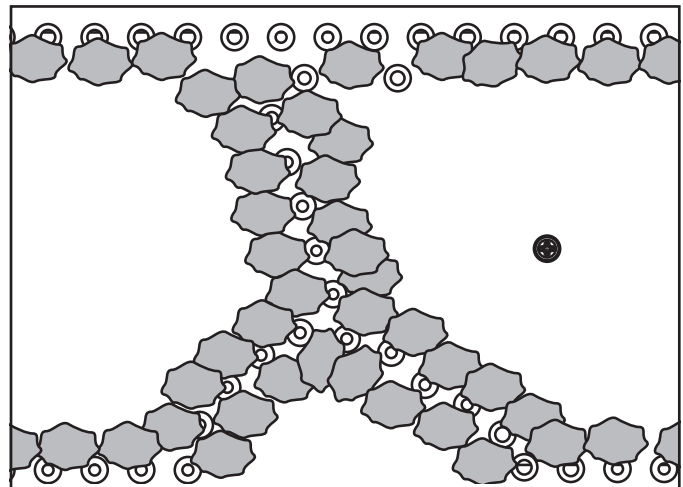

Figure 11.9 Embers Overlapping Burner Port Holes (LP & ULPG only).

G. Install the Teco-Sil

Cleaning the Teco-Sil

During shipment of the teco-sil, dust and debris can accumulate. It is recommended that the teco-sil be rinsed thoroughly with water to remove dust and small particles. An easy method to clean the teco-sil is to place the teco-sil into a pail and rinse thoroughly. Spread the teco-sil out over paper towels and allow the teco-sil to dry before installing them into the fireplace.

Teco-Sil Placement

1. Pour Teco-Sil between the left and right base refractories as shown in Figure 11.10

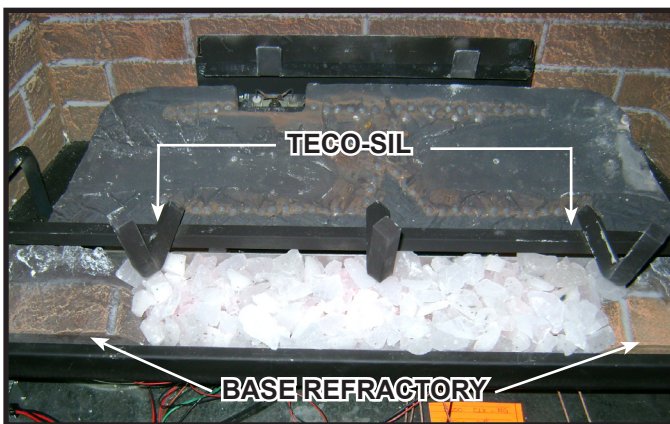

Figure 11.10 Placement of Teco-Sil

2. Fog the Teco-Sil to the desired look, using high temperature black paint (Hearth & Home Technologies part number TUP-GBK-12). See below for fogging tips. Prior to painting, take precautions to prevent any overspray from reaching the pilot assembly.

Fogging Tips

- Apply paint with the ember lights turned on. This will help you avoid over fogging or under fogging.
- Reduce the lighting in the room while applying the paint.
- Fog the Teco-Sil to create a realistic coal bed appearance.
- Allow the paint to dry/cure a minimum of 15 minutes.

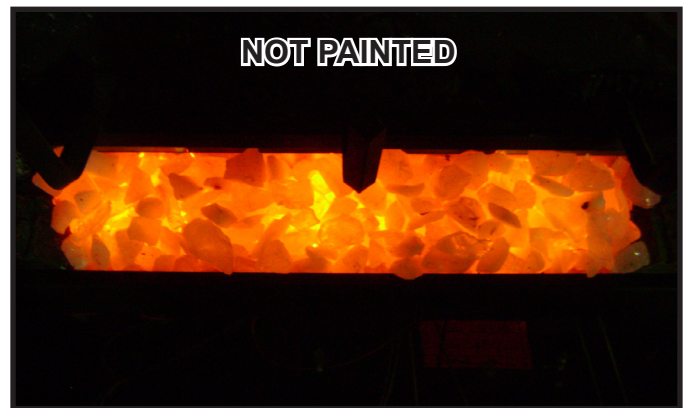

Figure 11.11 Teco-Sil Not Painted

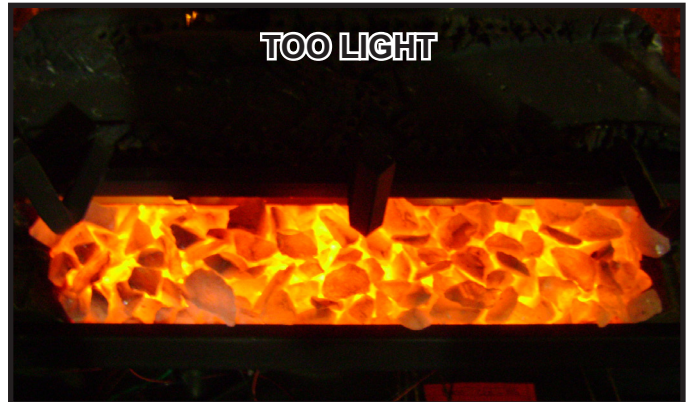

Figure 11.12 Teco-Sil Too Light

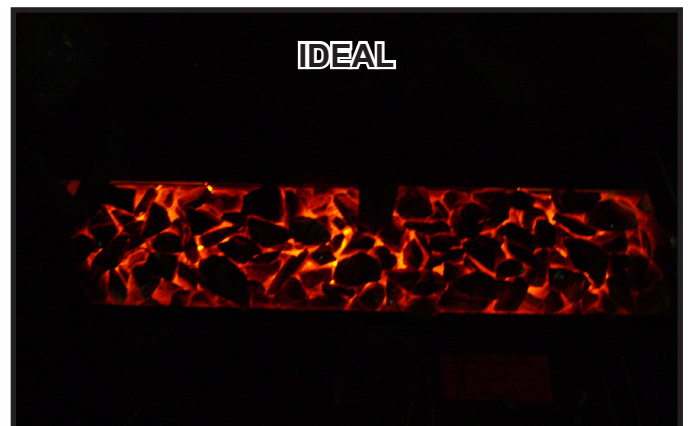

Figure 11.13 Teco-Sil Ideal

H. Install the Log Assembly

Log Assembly: LOGS-6X-AU



Figure 1

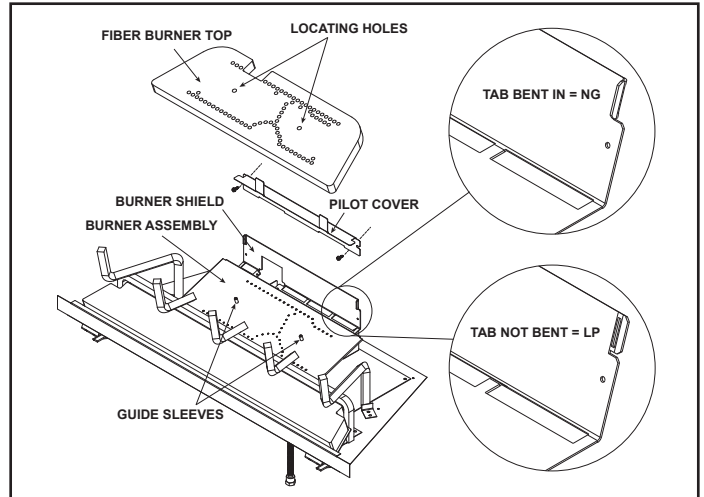

Figure 2

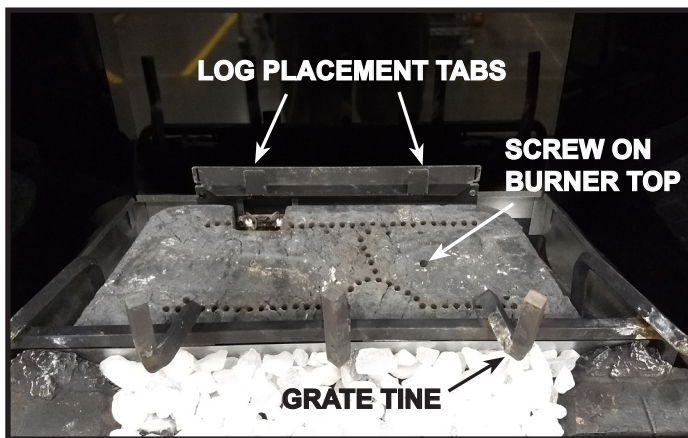

Figure 3

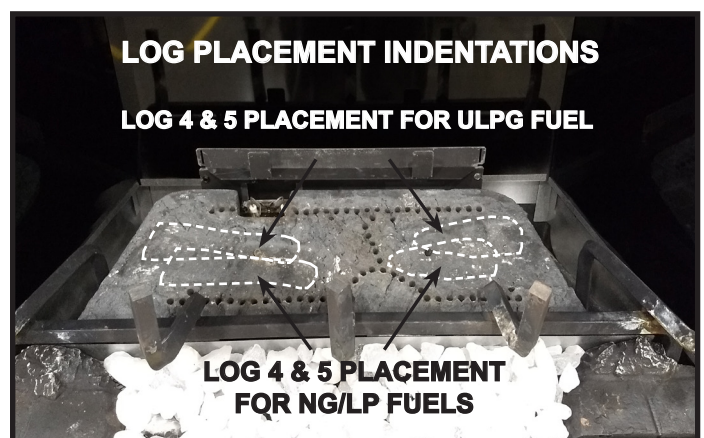

Figure 4

CAUTION: Logs are fragile, handle with care. **Log #1 (SRV2164-701):** Locate log placement tabs on the pilot cover. Bend tabs upward as shown in Figure 3. Locate the log placements slots on the bottom of Log #1 (see Figure 5). Mate the slots located on the bottom of Log #1 with the log placement tabs on the pilot cover. Log #1 is properly installed when it sits squarely and completely on pilot cover with tabs engaged (see Figure 6).

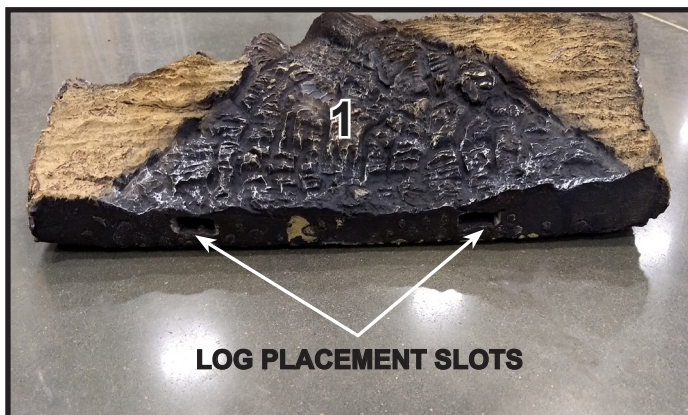

Figure 5

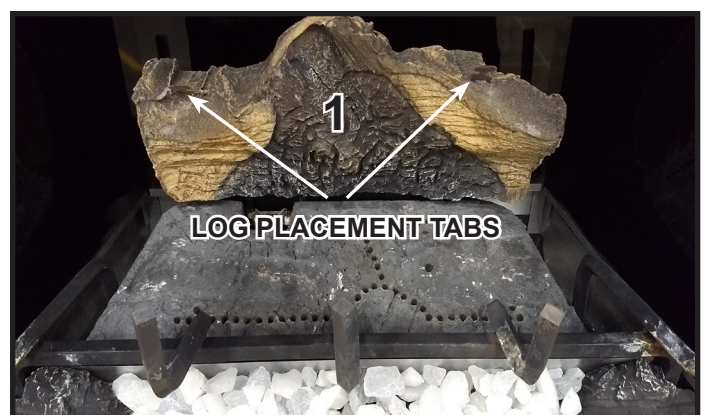

Figure 6

Figure 6 shows the log placement tabs located on the top of Log #1. The tabs will be mated with the slots located on the bottom of Log #2 and Log #3 (see Figure 7). Log #2 and Log #3 also have grooves that allow the logs to be seated properly on the grate (see Figure 7). Hold Log #1 upright while placing Log #2.

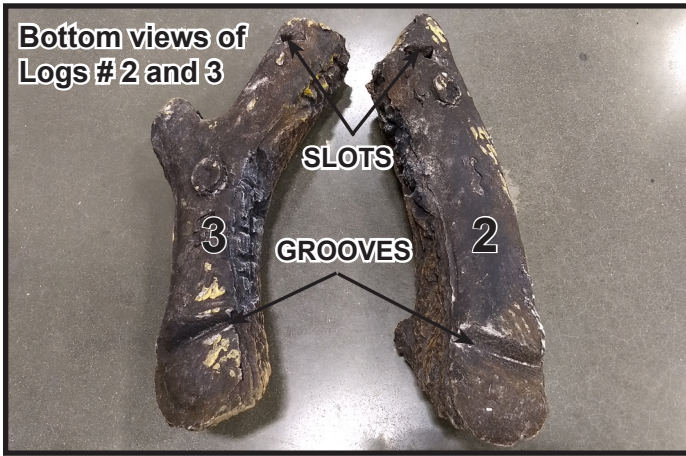

Figure 7



Figure 8

Log #2 (SRV2164-702): Mate the slot located on the bottom of Log #2 with the left log placement tab on top of Log #1. After slot and tab have been fitted together, mate the groove located on the bottom of Log #2 with the horizontal grate bar and slide Log #2 toward the left until it rests against the far left grate tine.



Figure 9

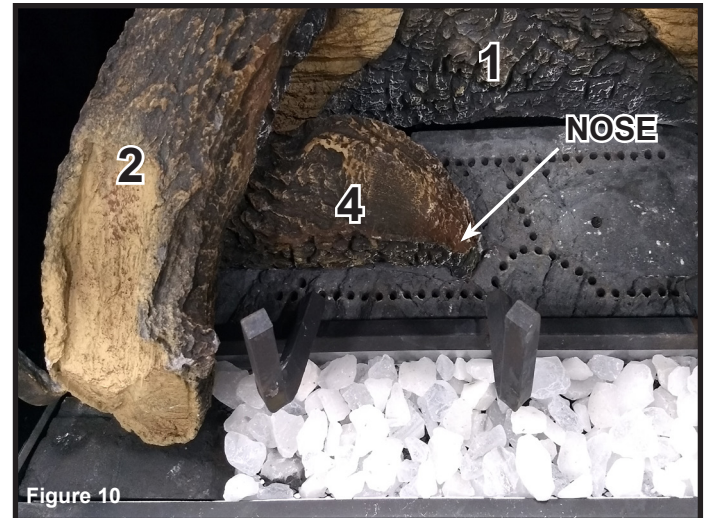

Figure 10

Log #3 (SRV2164-703): Mate the slot located on the bottom of Log #3 with the right log placement tab on top of Log #1. After slot and tab have been fitted together, mate the groove located on the bottom of Log #3 with the horizontal grate bar and slide Log #3 toward the right until it rests against the far right grate tine (see Figure 9).

Log #4 (SRV2164-704): NG/LP FUELS Place Log #4 in the left log indentation on the burner top (see Figure 4). Slide Log #4 from right to left under Log #2 to fit completely and securely into the indentation (see Figure 10). Nose of log #4 should be pulled to fit securely against right hand side of log indentation.

Log #4 (SRV2164-704): ULPG FUEL Place Log #4 in the left log indentation on the burner top (see Figure 4). Slide Log #4 to the rear and to the left under Log #2 to fit securely against the rear of the indentation and left until it stops.

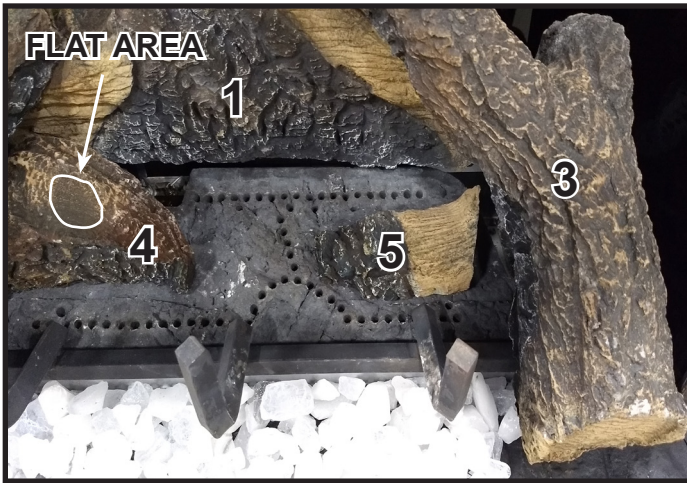

Figure 11

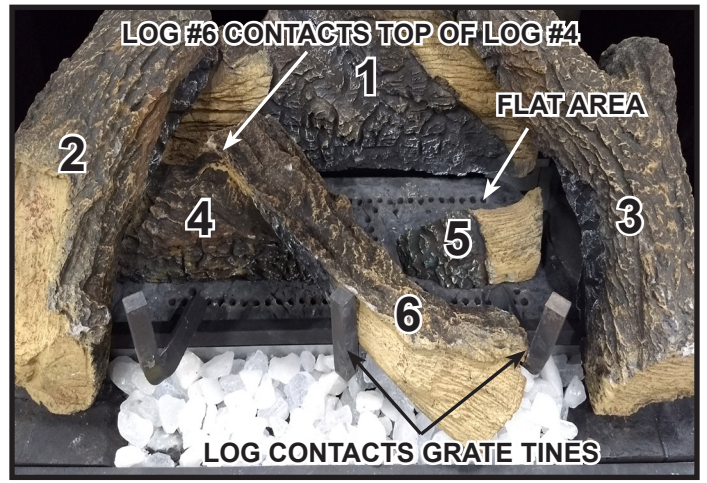

Figure 12

Log #5 (SRV2164-705): NG/LP FUELS Place Log #5 in the right log indentation on the burner top (see Figure 4). Ensure the log fits completely and securely in the recessed indentation (see Figure 11). Log #5 should be pulled to the left hand side of log indentation.

Log #5 (SRV2164-705): ULPG FUEL Place Log #5 in the right log indentation on the burner top under Log #3 (see Figure 4). Slide the log to the rear of the indentation and right until the tip of the log is just covering the mounting screw on the top of the burner (see Figure 3).

Log #6 (SRV2164-706): Mate the groove located on the lower end of Log #6 with the fourth grate tine (from left to right) as shown in Figure 12. Set the other end of Log #6 on the flat area located on top of Log #4 (see Figure 11). Log #6 will also rest against center grate tine. When properly installed, Log #6 will rest securely on all 3 contact points, not allowing movement or shifting.

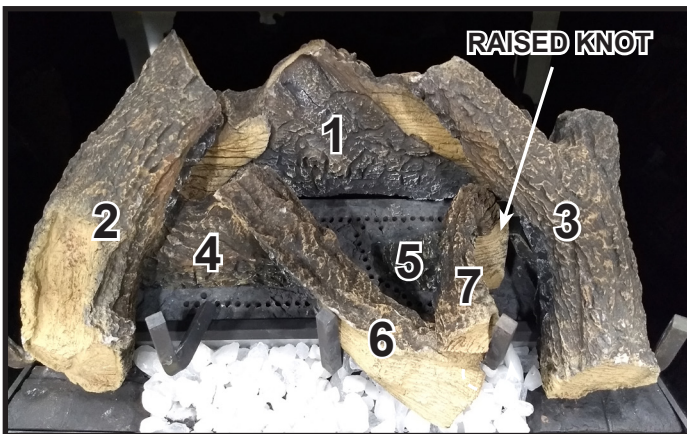

Figure 13

Log #7 (SRV2165-707): Place back (unnotched) end of Log #7 on the flat area on the top of Log #5. Log #7 must be pulled tight to the locating notch. Pivot the front (notched) end of Log #7 to the right until the notch of Log #7 contacts the grate tine located 4th from the left as shown in Figure 13.

I. Install Fixed Glass Assembly

WARNING! Risk of Asphyxiation! Handle fixed glass assembly with care. Inspect the gasket to ensure it is undamaged and inspect the glass for cracks, chips or scratches.

- **DO NOT** strike, slam or scratch glass.
- **DO NOT** operate fireplace with glass removed, cracked, broken or scratched.
- Replace as a complete assembly.

Replacing Fixed Glass Assembly

- Replace the glass door on the appliance. Pull out and latch the four glass assembly latches into the groove on the glass frame. See Figure 11.1.

J. Install Decorative Front

WARNING! Risk of Fire! Install **ONLY** doors or fronts approved by Hearth & Home Technologies. Unapproved doors or fronts could cause fireplace to overheat.

This fireplace has been supplied with an integral barrier to prevent direct contact with the fixed glass panel. DO NOT operate the fireplace with the barrier removed.

Contact your dealer or Hearth & Home Technologies if the barrier is not present or help is needed to properly install one.

For more information refer to the instructions supplied with your decorative front.

12 Reference Materials

A. Vent Components Diagrams

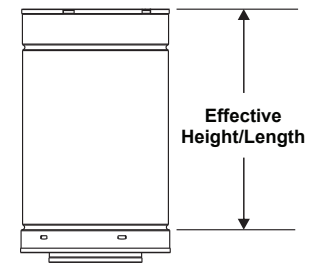

DVP Pipe (see chart)

Pipe	Effective Length	
	Inches	Millimeters
DVP4	4	102
DVP6	6	152
DVP12	12	305
DVP24	24	610
DVP36	36	914
DVP48	48	1219
DVP6A	3 to 6	76 to 152
DVP12A	3 to 12	76 to 305

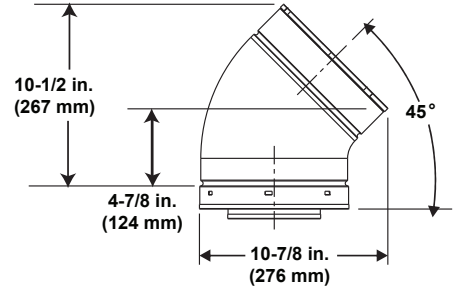

DVP45 (45° Elbow)

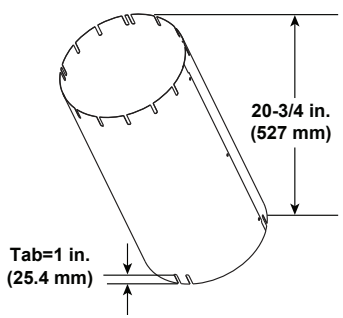

Finished Height: 19-3/4 in./502 mm
UNIV-AS2 (Attic Insulation Shield)

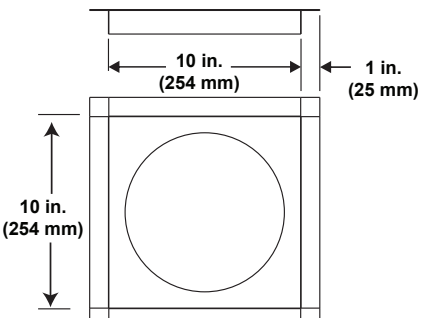

DVP-FS (Ceiling Firestop)

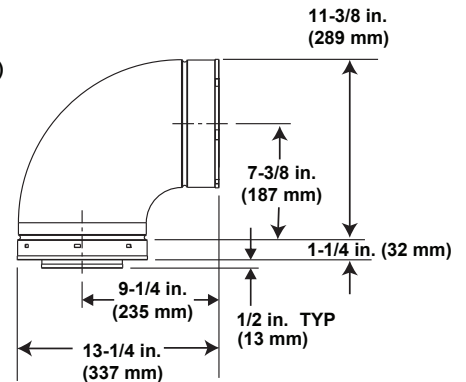

DVP90ST (90° Elbow)

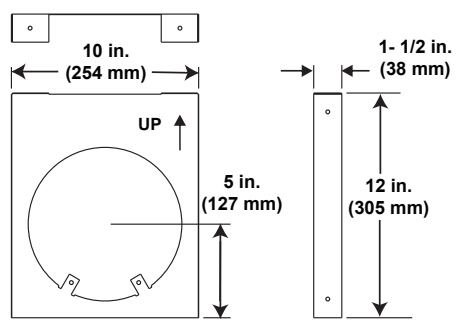

DVP-HVS (Vent Support)

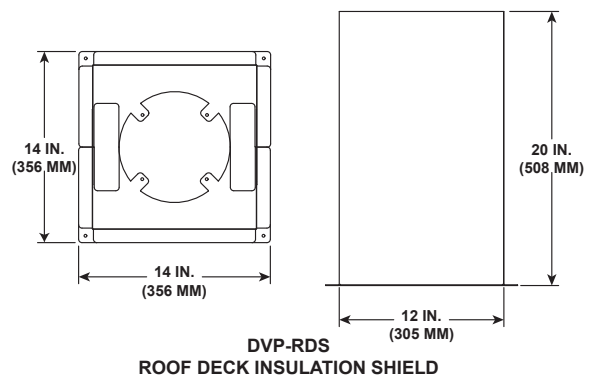

DVP-RDS
ROOF DECK INSULATION SHIELD

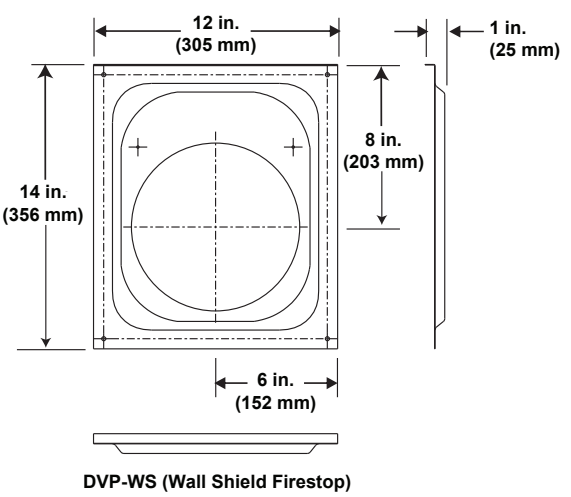

DVP-WS (Wall Shield Firestop)

Figure 12.1 DVP Vent Components

A. Vent Components Diagrams (continued)

Note: Heat shields MUST overlap by a minimum of 1-1/2 in. (38 mm). **The heat shield is designed to be used on a wall 4 in. to 7-1/4 in. (102 mm to 184 mm) thick.** If wall thickness is less than 4 in. (102 mm) the existing heat shields must be field trimmed. If wall thickness is greater than 7-1/4 in. (184 mm) a DVP-HSM-B will be required.

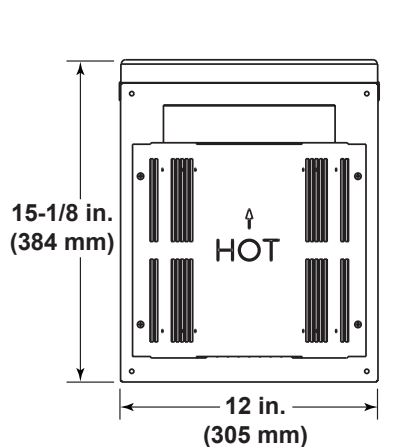

DVP-TRAP2
Horizontal Termination Cap

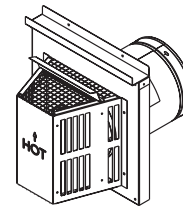
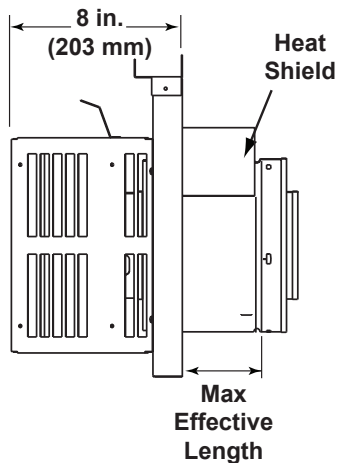

Term Cap	Minimum Effective Length	Maximum Effective Length
Trap1	3-1/8 in.	4-5/8 in.
	79 mm	117 mm
Trap2	5-3/8 in.	9-3/8 in.
	137 mm	238 mm

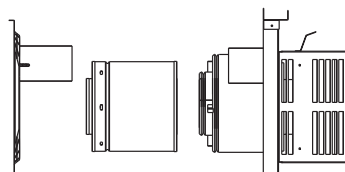

DVP-TRAP2

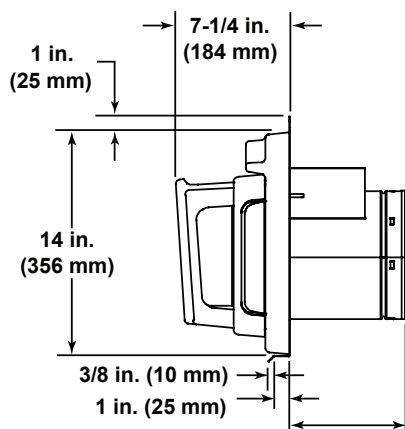

7-3/4 to 10-3/8 in.
(197 to 264 mm)

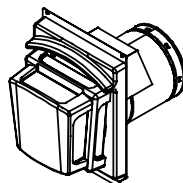

DVP-FBHT
FireBrickTermination Cap

Figure 12.2 DVP Vent Components

A. Vent Components Diagrams (continued)

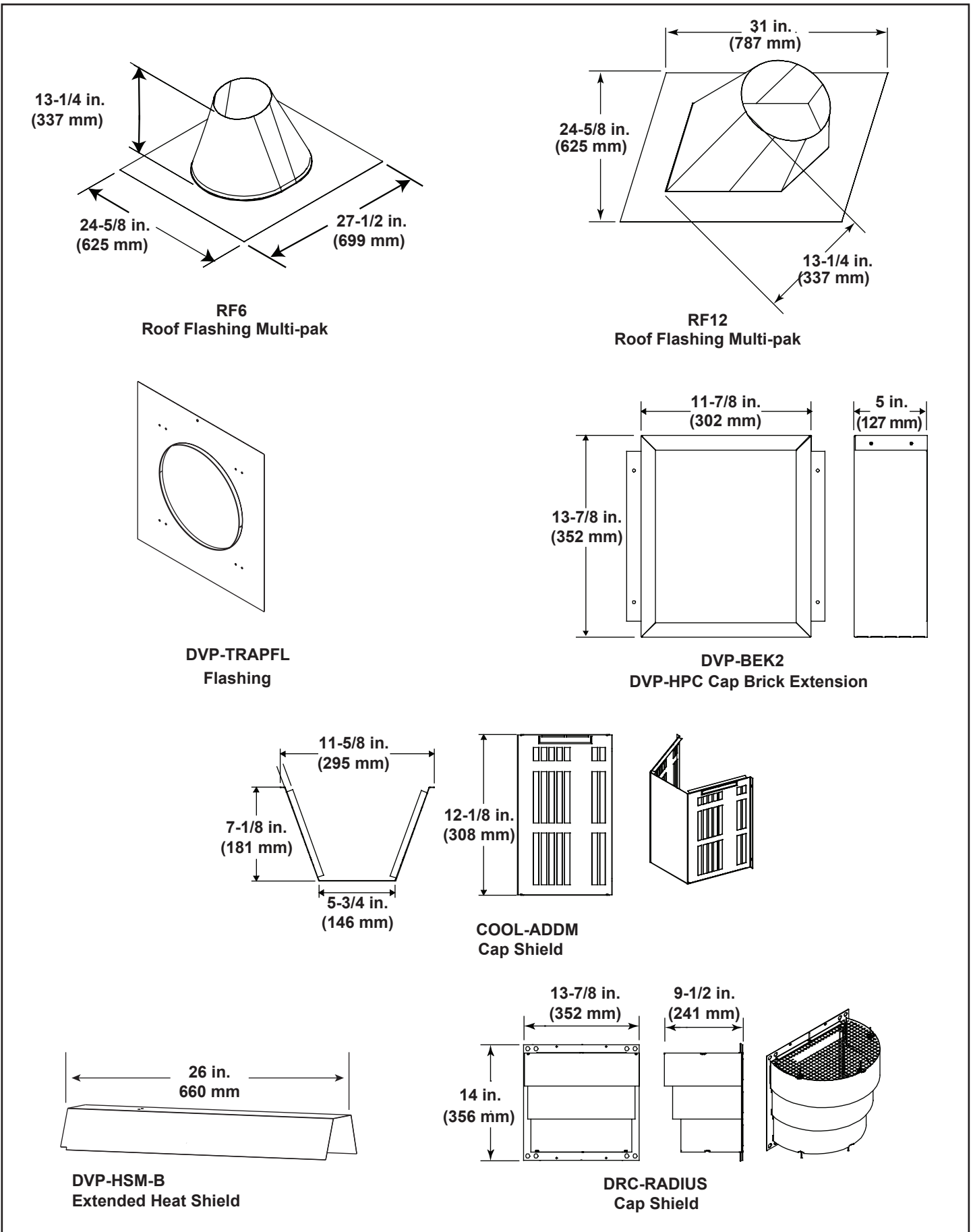

Figure 12.3 DVP Vent Components

A. Vent Components Diagrams (continued)

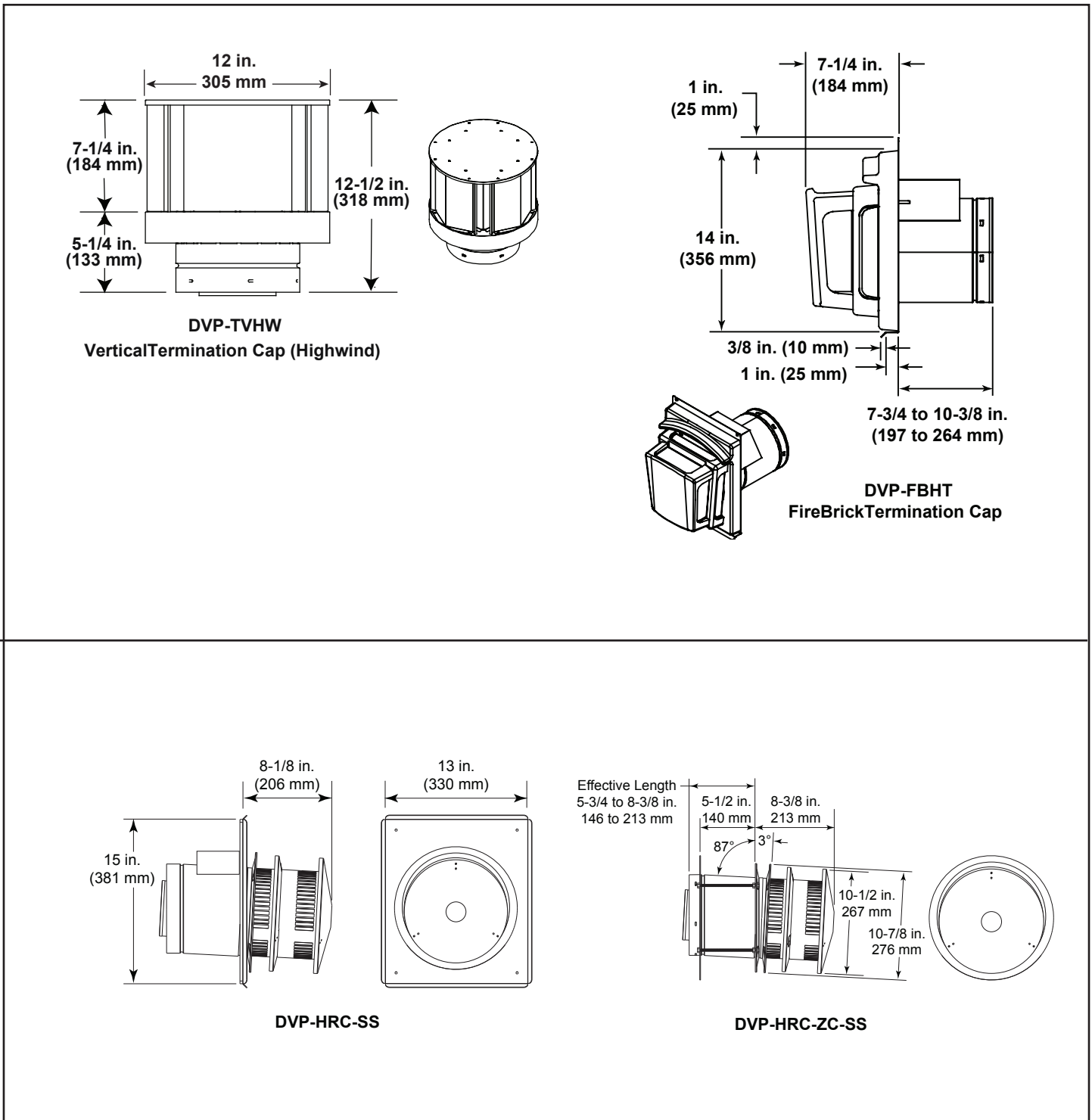

Figure 12.4 DVP Vent Components

A. Vent Components Diagrams (continued)

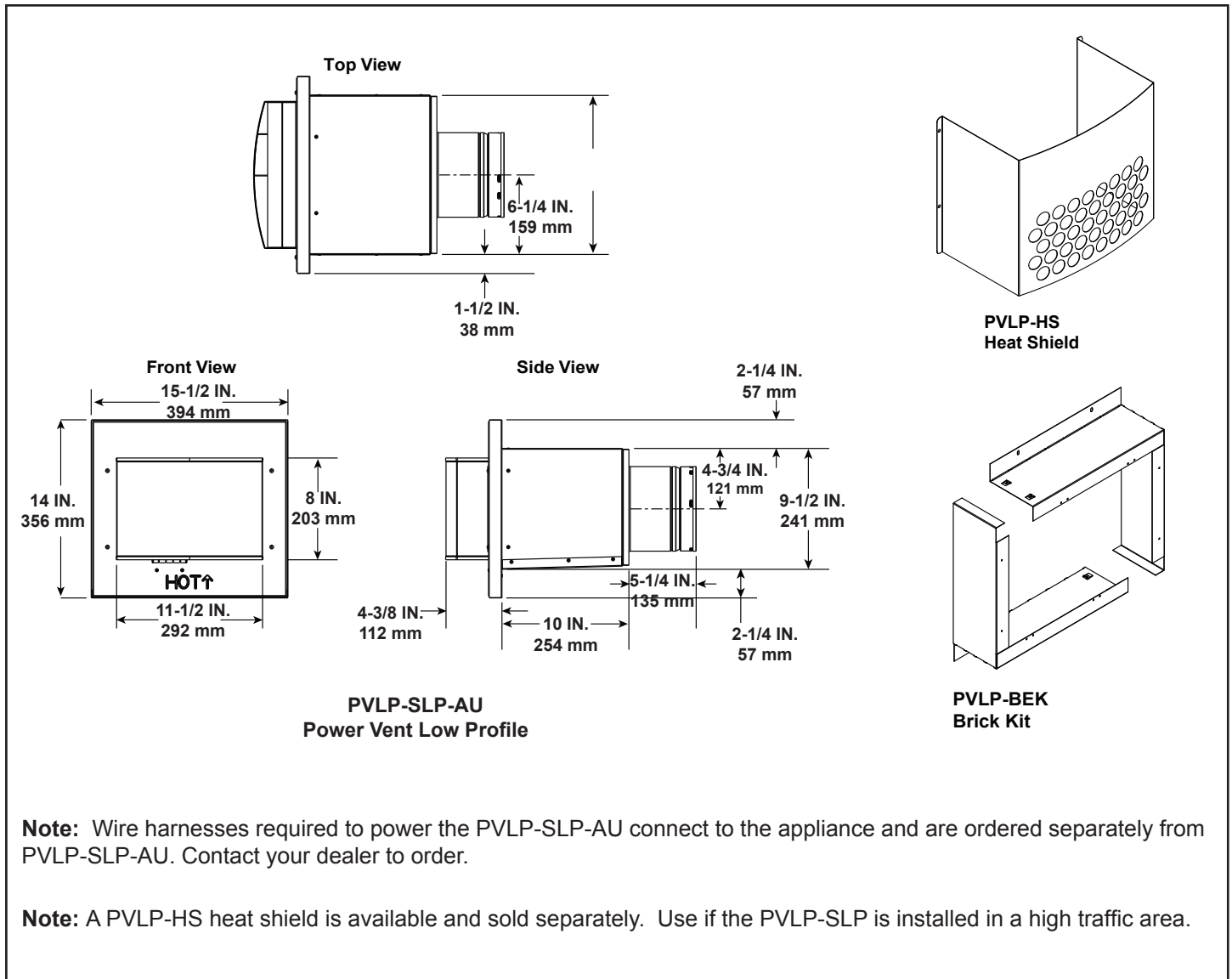

Figure 12.5 PVLP-SLP-AU Vent Components

B. Accessories

Remote Controls, Wall Controls and Wall

Switches

Follow the instructions supplied with the control installed to operate your fireplace:

For safety:

- Install a switch lock or a wall/remote control with child protection lockout feature.
- Keep remote controls out of reach of children.

See your dealer if you have questions.

Optional Heat-Zone®-240V Kit

Follow the instruction supplied with the kit for operation.

- Preparation of the appliance for installation of the kit is discussed in Section 6.B.

Contact your dealer if you have questions.

Optional Fiber Refractory Kit

Follow the instructions supplied to install the kit. Contact your dealer if you have questions.

Heat & Glo, a brand of Hearth & Home Technologies
7571 215th Street West, Lakeville, MN 55044
www.heatnglo.com

Please contact your Heat & Glo dealer with any questions or concerns.
For the location of your nearest Heat & Glo dealer,
please visit www.heatnglo.com.

Printed in U.S.A. - Copyright 2021