

# Owner's Manual

## Care and Operation

**INSTALLER:** Leave this manual with party responsible for use and operation.

**OWNER:** Retain this manual for future reference.

Contact your local dealer with questions on installation, operation or service.

**NOTICE: SAVE THESE INSTRUCTIONS**

# HARMAN®

**BUILT TO A STANDARD, NOT A PRICE**

**Model(s):**

**Allure50 Freestanding Pellet Stove**

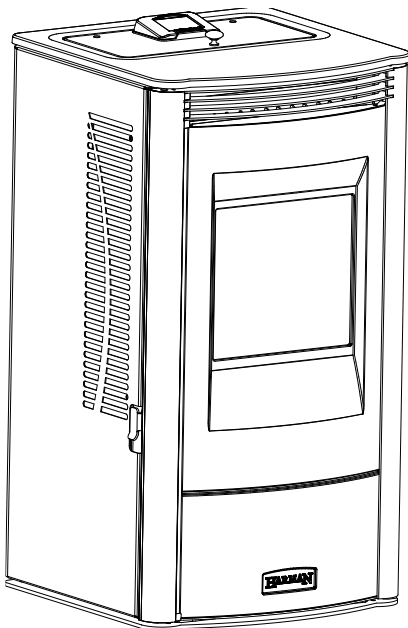

### **WARNING**



Please read this entire manual before installation and use of this pellet fuel-burning room heater.

Failure to follow these instructions could result in property damage, bodily injury or even death.

- Do not store or use gasoline or other flammable vapors and liquids in the vicinity of this or any other appliance.
- Do not overfire - If any external part starts to glow, you are overfiring. Reduce feed rate. Overfiring will void your warranty.
- Comply with all minimum clearances to combustibles as specified. Failure to comply may cause house fire.

### **WARNING**

#### **HOT SURFACES!**



Glass and other surfaces are hot during operation AND cool down.

**Hot glass will cause burns.**

- Do not touch glass until it is cooled
  - NEVER allow children to touch glass
  - Keep children away
  - CAREFULLY SUPERVISE children in same room as stove.
  - Alert children and adults to hazards of high temperatures.
- High temperatures may ignite clothing or other flammable materials.**
- Keep clothing, furniture, draperies and other flammable materials away.

### **CAUTION**

Check building codes prior to installation.

- Installation **MUST** comply with local, regional, state and national codes and regulations.
- Contact local building or fire officials about restrictions and installation inspection requirements in your area.

### **CAUTION**

Tested and approved for wood pellet fuel only. Burning of any other type of fuel voids your warranty.

### **NOTE**

To obtain a French translation of this manual, please contact your dealer or visit [www.harmanstoves.com](http://www.harmanstoves.com).

Pour obtenir une traduction française de ce manuel, s'il vous plaît contacter votre revendeur ou visitez [www.harmanstoves.com](http://www.harmanstoves.com).

**Read this manual before operating this appliance.  
Please retain this Owner's Manual for future reference.  
Read the Installation Manual before making any installation or finishing changes.**

**Congratulations,** The Harman® Allure50 pellet stove you have selected is designed to provide the utmost in safety, reliability, and efficiency.

As the owner of a new pellet stove, you'll want to read and carefully follow all of the instructions contained in this owner's manual. Pay special attention to all cautions and warnings.

This owner's manual should be retained for future reference. We suggest that you keep it with your other important documents and product manuals.

Your new Harman® Allure50 Freestanding Pellet Stove will give you years of durable use and trouble-free enjoyment. Welcome to the Harman® family!

**Note: Cast iron is an artisan crafted material, which is made the same way today as nearly 2000 years ago. Due to the intrinsic primitive nature of the casting process, part to part variation is normal and adds to the character of a hand built cast iron appliance**

**Listing Label Information/Location**

The model information regarding your specific stove can be found on the rating plate usually located in the control area of the stove.

**Model Name**      **Serial Number**

**MODEL / MODÈLE** Allure50®  
Room Heater Pellet Fuel-Burning Type  
SUITABLE FOR MOBILE-HOME INSTALLATION  
This pellet burning appliance has been tested and listed for use in Manufactured Homes in accordance with OAR 814-23-900 through 814-23-909

**Report #/Rapport #** 0135P50375, 0135P5037E  
**Test to/Tests à:** ASTM E 2779-10, ASTM E 2515-11, ASTM E 1509-12, ULC-S627-00, EPA Method 28R  
**Test date:** September 2015  
Room Heater, Pellet Fuel-Burning Type, Also For Use in Mobile Homes, (UM) 84-HUD  
**"PREVENT HOUSE FIRES"** Install and use only in accordance with manufactures installation and operation instructions.  
Contact local building or fire officials about restrictions and installation inspection in your area.  
**WARNING: FOR MANUFACTURED HOMES:** Do not install appliance in a sleeping room. An outside combustion air inlet must be provided. The structural integrity of the manufactured home floor, ceiling and walls must be maintained.  
Refer to manufacturer's instructions and local codes for precautions required for passing chimney through a combustible wall or ceiling. Inspect and clean exhaust venting system frequently in accordance with manufacturer's instructions.  
Use a 3" or 4" diameter type "L" or "PL" venting system.  
Do not connect this unit to a chimney flue servicing another appliance.  
Do not obstruct the space beneath the heater.  
**FOR USE WITH PELLETIZED WOOD FUEL ONLY.**  
EPA Certified Emissions: 1.49 g/hr  
**Input Rating Max:** 6.6 lb. fuel/hr  
**Electrical Rating:** 240 VAC, 50 Hz, Start 1.75 AMPS, Run 1.25 AMPS  
**U.S. Electrical Rating:** 115 VAC, 60 Hz, Start 3.5 AMPS, Run 2.5 AMPS  
Fuel Type: Wood Pellet ONLY  
Route power cord away from unit.  
**OPERATE ONLY WITH DOORS CLOSED**

**DANGER:** Risk of electrical shock. Disconnect power supply before replacing glass. Replace glass only with 5mm ceramic available from your dealer. For further instruction refer to owner's manual. Keep viewing and ash removal doors tightly closed during operation.

**MINIMUM CLEARANCES TO COMBUSTIBLES**  
Back Wall to Appliance 2"  
Side Wall to Appliance 6"  
**Corner Installation**  
Walls to Appliance 6.25"  
Use a non-combustible floor protector extending under and to the sides, front and back of the unit as shown in floor protection diagram. Measure front distance from the surface of the glass door.  
**Recommended: Non-combustible floor protection extended beneath the flue pipe when installed with horizontal venting.**

	USA	CANADA
Sides (A)	6"	152 mm
Back (B)	1"	25 mm
Front (C)	6"	152 mm

**Floor Protection\***  
Min. Alcove Height 42" (1067mm)  
Max. Alcove Depth 24" (610mm)

**Alcove Installation**  
Min. Alcove Height 42" (1067mm)  
Max. Alcove Depth 24" (610mm)

**NO LISTING EXAMPLE**

**Modèle: ALLURE50**  
Appareil de chauffage à granulés de bois  
CONÇU POUR MAISONS PRÉFABRIQUÉES

Test pour / tested à la norme ASTM E 2779-10, ASTM E 2515-11, ASTM E 1509-12, ULC-S627-00, EPA Method 28R  
Chaudière à granulés de bois  
les normes de la norme ASTM E 2779-10, ASTM E 2515-11, ASTM E 1509-12, ULC-S627-00, EPA Method 28R

**Serial No / N° de série:** HF

**BARCODE LABEL**

**DANGER:** Risque d'électrocution. Coupez l'alimentation électrique avant l'entretien.  
Remplacer le verre avec 5 mm miroir verre céramique de la même qualité disponible auprès de votre revendeur. En tenant la porte d'entrée et le couvercle de la trémie hermétiquement fermés pendant le fonctionnement de l'appareil.

**POUR MAISONS PRÉFABRIQUÉES:** Ne pas installer dans une chambre à coucher. Une entrée d'air de combustion à l'extérieur doit être fournie. L'intégrité structurelle de la maison étage, plafond et murs fabriqués doit être maintenue.  
Reportez-vous aux instructions du fabricant et les codes locaux pour les précautions nécessaires pour faire passer la cheminée à travers un mur ou un plafond combustible. Inspectez et nettoyez système d'évacuation souvent en conformité avec les instructions du fabricant.  
Utilisez un "ou 4" Type de diamètre «L» 3 ou le système de ventilation "PL".  
Ne pas connecter cet appareil à un conduit de cheminée desservant un autre appareil.  
**Ne pas obstruer l'espace sous le chauffe-eau.**  
**À UTILISER AVEC LA GRANULE DE BOIS SEULEMENT.**  
Emissions certifiées EPA: 1,49 g / h  
**Entrée Max Note:** E 6,6 carburant / h  
**Note électrique:** 240 VAC, 50 Hz, Lancer 1,75 AMPS, Exécuter 1,25 AMPS  
**US Note électrique:** 115 VAC, 60 Hz, 3,5 AMPS Démarrer, Exécuter 2,5 AMPS  
Type de carburant: Bois Pellet SEULEMENT  
Route cordon électrique de l'appareil.  
Fonctionner uniquement avec les portes fermées

**DISTANCES DE SÉCURITÉ PAR RAPPORT AUX MATÉRIELS COMBUSTIBLES**  
Paroi arrière à l'appareil 51 mm  
Paroi latérale de l'appareil 152 mm  
**Installation en angle**  
Entre murs et appareil 159 mm  
**Installation en alcove**  
Hauteur minimale de l'alcove 1295 mm  
Profondeur maximale de l'alcove 610 mm  
**PROTECTION DU SOL\***  
Côtés (A) 152 mm  
Arrière (B) 25 mm  
Avant (C) 152 mm  
Utiliser une protection de sol non combustible sous l'appareil qui s'étend sur les côtés, l'avant et l'arrière du poêle (voir schéma). Pour la distance à l'avant, mesurer à partir de la surface de la porte en verre.  
Il est recommandé que la protection s'étende jusque sous le conduit en cas d'installation d'un conduit horizontal ou sous le té en cas conduit vertical.  
**Do not remove this label/Ne pas enlever cette étiquette.** Made in the USA/Fabriqué aux E.-U.

**US ENVIRONMENTAL PROTECTION AGENCY (Allure50)**  
Certified to comply with 2020 particulate emission standards.  
Certifié conforme aux normes 2020 d'émission de particules.

**Date of Manufacture / Date de fabrication:**

2023	2024	2025	JAN	FEB	MAR	APR	MAY	JUN	JUL	AUG	SEP	OCT	NOV	DEC
■	■	■	■	■	■	■	■	■	■	■	■	■	■	■

Manufactured by / Fabriqué par: Hearth and Home Technologies 352 Mountain House Road, Halifax PA 17032

3-90-088\_R7

# Table of Contents

## 1 Product Specifications and Important Safety Information

A. Appliance Certification / Specifications	4
B. Mobile Home Approval	4
C. BTU & Efficiency Specifications	4
D. Appliance Safety	5
E. Clear Space	5
F. California Safety Information	5
G. Helpful Hints	6
H. Fuel Specifications	6
I. Quick Start Guide	8
J. Frequently Asked Questions	9
K. Cleaning Prompts, Messages and Errors	10

## 2 Maintenance and Service

A. Proper Shutdown Procedure	11
B. Quick Reference Maintenance Chart	12
C. Unit Maintenance	13
• Daily/Weekly Maintenance	13
• Monthly Maintenance	13
• Yearly Maintenance	14

## ▲ Safety Alert Key:

- **DANGER!** Indicates a hazardous situation which, if not avoided **will** result in death or serious injury.
- **WARNING!** Indicates a hazardous situation which, if not avoided **could** result in death or serious injury.
- **CAUTION!** Indicates a hazardous situation which, if not avoided, could result in minor or moderate injury.
- **NOTICE:** Used to address practices not related to personal injury.

## 3 Reference Materials

→ A. Service Parts	16
B. Limited Lifetime Warranty	22
C. Loss of Power	24
D. Emergency Manual Ignition	24
E. Troubleshooting	25
F. Glass Installation and Cleaning	26
G. Contact Information	28

→ = Contains updated information

# 1 Product Specifications and Important Safety Information

## A. Appliance Certification / Specifications

<b>MODEL:</b>	Allure50 Pellet Stove
<b>LABORATORY:</b>	OMNI Test Laboratories, Inc
<b>REPORT NO.</b>	0135PS037S, 0135PS037E
<b>TYPE:</b>	Pellet Fueled/Supplementary For Residential Use
<b>STANDARD(s):</b>	ASTM E 2779-10, ASTM E 2515-11, ASTM E 1509-12, ULC-S627-00, EPA Method 28R
<b>ELECTRICAL RATING:</b>	115 VAC, 60 Hz, Start 3.5 AMPS, Run 2.5 AMPS
<b>GLASS SPECIFICATION:</b>	5mm mirrored ceramic glass

The Allure50 is certified to comply with 2020 particulate emission standards.



**NOTE:** This installation must conform with local codes. In the absence of local codes you must comply with the **ASTM E 1509-12, ULC-S627-00, (UM) 84-HUD**

## B. Mobile Home Approval

This appliance is approved for mobile and manufactured home installations when not installed in a sleeping room and when an outside combustion air inlet is provided.

The structural integrity of the mobile home floor, ceiling, and walls must be maintained. The appliance must be properly grounded to the frame of the mobile home and use only listed pellet vent, Class "PL" or "L" connector pipe.

A Harman® Outside Air Kit must be installed in a mobile home installation.



### WARNING

**THE STRUCTURAL INTEGRITY OF THE MANUFACTURED HOME FLOOR, WALL, AND CEILING/ROOF MUST BE MAINTAINED.**

**DO NOT INSTALL IN SLEEPING ROOM.**

**NOTE:** Hearth & Home Technologies, manufacturer of this appliance, reserves the right to alter its products, their specifications and/or price without notice.

Harman® is a registered trademark of Hearth & Home Technologies.

## C. BTU & Efficiency Specifications

<b>EPA Certification Number:</b>	50-16
<b>EPA Certified Emissions:</b>	1.48 g/hr
<b>*LHV Tested Efficiency:</b>	79.9%
<b>**HHV Tested Efficiency:</b>	74.6%
<b>***EPA BTU Output:</b>	39,100
<b>****BTU Input</b>	52,600
<b>Vent Size:</b>	3 Inch
<b>Hopper Capacity:</b>	92 lbs
<b>Fuel</b>	Wood Pellet

\* Weighted average LHV efficiency using data collected during EPA emissions test.

\*\*Weighted average HHV efficiency using data collected during EPA emissions test.

\*\*\*A range of BTU outputs based on EPA Default Efficiency and the burn rates from the maximum EPA test.

\*\*\*\*Based on the maximum feed rate per hour multiplied by approximately 8600 BTU's which is the average BTU's from a pound of pellets.

This wood heater has a manufacturer-set minimum low burn rate that must not be altered. It is against federal regulations to alter this setting or otherwise operate this wood heater in a manner inconsistent with operating instructions in this manual.

This wood heater needs periodic inspection and repair for proper operation. It is against federal regulations to operate this wood heater in a manner inconsistent with operating instructions in this manual.

**Risk of Fire!** *Hearth & Home Technologies disclaims any responsibility for, and the warranty and agency listing will be voided by the below actions.*

### DO NOT:

- Install or operate damaged appliance.
- Modify appliance.
- Install other than as instructed by *Hearth & Home Technologies*.
- Operate the appliance without fully assembling all components.
- Overfire.
- Install any component not approved by *Hearth & Home Technologies*.
- Install parts or components not Listed or approved.
- Disable safety switches.

*Improper installation, adjustment, alteration, service or maintenance can cause injury or property damage.*

*For assistance or additional information, consult a qualified installer, service agency or your dealer.*

## D. Appliance Safety

### WARNING

If you expect that small children or vulnerable adults may come into contact with this appliance, the following precautions are recommended:

- Install a physical barrier such as:
  - A decorative fire screen.
  - Adjustable safety gate.
- Never leave children alone near a hot stove, whether operating or cooling down.
- Teach children to **NEVER** touch the stove.
- Consider not using the stove when children will be present.
- Use only specified components as replacement parts. Other components may not allow your stove to operate as it was intended.

Contact your dealer for more information, or visit: [www.hpba.org/safety-information](http://www.hpba.org/safety-information).

To prevent unintended operation when not using your stove for an extended period of time (summer months, vacations, trips, etc):

- Unplug stove from receptacle.

Due to high temperatures, this stove should be placed away from traffic, furniture and draperies.

Children and adults should be alerted to the hazards of high surface temperatures and should stay away to avoid burns to the skin and/or clothing.

Young children should be carefully supervised when they are in the same room as the stove.

Clothing and other flammable materials should not be placed on or near this stove.

Installation and repair of this stove should be done by a qualified service person. The appliance should be inspected before use and at least annually by a qualified service person. More frequent cleaning will be required. It is imperative that control compartments and circulating air passageways of this stove be kept clean.

Connect the power cord into a 120 VAC, 60 Hz grounded receptacle. (A surge protector is recommended to protect the circuit board.) Be sure the polarity of the outlet the stove is plugged into is correct.

### WARNING

**THIS WOOD HEATER HAS A MANUFACTURER-SET MINIMUM LOW BURN RATE THAT MUST NOT BE ALTERED. IT IS AGAINST FEDERAL REGULATIONS TO ALTER THIS SETTING OR OTHERWISE OPERATE THIS WOOD HEATER IN A MANNER INCONSISTENT WITH OPERATING INSTRUCTIONS IN THIS MANUAL.**

## E. Clear Space

### WARNING

**RISK OF FIRE! Do NOT place combustible objects in front or to the sides of the appliance. High temperatures may ignite clothing, furniture or draperies.**

**NOTICE:** Clearances may only be reduced by means approved by the regulatory authority having jurisdiction.

### WARNING

**RISK OF FIRE! Keep combustible materials, gasoline and other flammable vapors and liquids clear of appliance.**

- Do **NOT** store flammable materials in the appliance's vicinity.
- Do **NOT** use gasoline, lantern fuel, kerosene, charcoal lighter fluid or similar liquids to start or "freshen up" a fire in this heater.

Keep all such liquids well away from the heater while it is in use as combustible materials may ignite.

### WARNING

**MOBILE/MANUFACTURED HOME GUIDELINES: DO NOT ALLOW INSTALLATION IN A SLEEPING ROOM.**

### WARNING

**USE OF IMPROPER FUELS, FIRESTARTERS OR ALTERING THE STOVE FOR HIGHER HEAT OUTPUT MAY CAUSE DAMAGE TO THE STOVE AND COULD RESULT IN A HOUSE FIRE. USE ONLY APPROVED FUELS AND OPERATION GUIDELINES**

## F. California Safety Information

### WARNING

This product and the fuels used to operate this product (wood), and the products of combustion of such fuels, can expose you to chemicals including lead and carbon black, which is known to the State of California to cause cancer, and carbon monoxide, which is known to the State of California to cause birth defects or other reproductive harm. For more information go to: [www.P65Warnings.ca.gov](http://www.P65Warnings.ca.gov)

## G. Helpful Hints

When operating your Harman® Allure50 Pellet Stove, follow basic safety standards. Read these instructions carefully before you attempt to operate the Allure50 Pellet Stove. Failure to do so may result in damage to property or personal injury and may void the product warranty.

**Cleaning Burn Pot:** Whenever your stove is not burning, take the opportunity to scrape the burn pot to remove carbon buildup. A vacuum cleaner is handy to remove the residue. Be sure the stove is cold if you use a vacuum.

Carbon buildup can be scraped loose with the fire burning using the special tool provided with your stove. Scrape the floor and sides of the burn pot. The carbon will be pushed out by the incoming fuel. Always wear gloves when scraping the burnpot.

**Disposal of Ash:** Ashes should be placed in a steel container with a tight fitting lid. The closed container of ashes should be placed on a non-combustible floor or on the ground, well away from all combustible materials, pending final disposal. If the ashes are disposed of by burial in soil or otherwise locally dispersed, they should be retained in the closed container until all cinders have thoroughly cooled. Other waste shall not be placed in this container.

**Soot and Flyash Formation and Need for Removal:** The products of combustion will contain small particles of flyash. The flyash will collect in the exhaust venting system and restrict the flow of the flue gases. Incomplete combustion, such as occurs during startup, shutdown, or incorrect operation of the room heater will lead to some soot formation which will collect in the exhaust venting system. The exhaust venting system should be inspected at least once every year to determine if cleaning is necessary.

When burning wood pellets on low, the potential exists for creosote to form. The venting system should be inspected periodically throughout the heating season to determine if creosote buildup has occurred. If a significant layer of creosote has accumulated (1/8" or more), it should be removed to reduce the risk of a chimney fire. If a fire occurs, call the fire department, shut down the stove, and evacuate the residence. Before using the appliance, have the venting system thoroughly inspected and replace any damaged components.

With any hearth appliance, installation of smoke detectors is recommended on every level of the home.

### **Possible causes of smoke detector activation:**

Paint curing process - Open a window near the appliance for the first few hours of burning.

Exhaust being drawn back inside the dwelling - Outside air connection to the appliance is necessary.

Vent leakage - Follow venting manufacturer's recommendations for sealing pipe joints.



## H. Fuel Specifications

The Allure50 Pellet Stove is approved for burning any grade of pelletized bio-mass fuel.

It should be noted, however, that higher ash content will require more frequent cleaning.

The moisture content of pellets must not exceed 8%. Higher moisture will rob BTU's and may not burn properly.

Fuel should **not** be stored within the stove installation clearances or within the space required for cleaning and ash removal.

### **Fuel and Fuel Storage**

Pellet fuel quality can fluctuate from manufacturer to manufacturer, and even from bag to bag.

Hearth & Home Technologies recommends using only fuel that is certified by the Pellet Fuels Institute (PFI).

#### Fuel Material

- Made from sawdust and/or other wood by-products
- Source material typically determines ash content

#### Higher Ash Content Material

- Hardwoods with high mineral content
- Bark and leaves as source material
- "Standard" grade pellets and other biomass

#### Lower Ash Content Material

- Softwood; pine, fir, etc.
- Materials with lower mineral content
- "Premium" grade pellets

#### Performance

- Higher ash content requires more frequent maintenance.
- "Premium" grade pellets will produce the highest heat output.
- Burning pellets longer than 1-1/2 inches (38mm) can cause inconsistent feeding and/or ignition.

#### Clinkers

- Minerals and other non-combustible materials, like sand, will turn into a hard glass-like substance when heated.
- Trees from different areas will vary in mineral content. For this reason, some fuels will produce more clinkers than others.

#### Moisture

- Always burn dry fuel. Burning fuel with high moisture content takes energy to dry and tends to cool the appliance thus, robbing heat from your home.
- Damp pellet fuel could turn back into sawdust which does not flow properly through the feed system.

## H. Fuel Specifications (Cont.)

### Storage

- Wood pellets should be left in their original sealed bag until ready to use, to prevent moisture.
- Do not store fuel within the specified clearance areas, or in a location that will interfere with routine cleaning and maintenance procedures.

### NOTICE

Hearth & Home Technologies is not responsible for stove performance or extra maintenance required as a result of using fuel with higher ash or mineral content.

### CAUTION

***Do not burn fuel that contains an additive.***

- May cause hopper fire
- Damage to product may result

Read the list of ingredients on the packaging.

### CAUTION

Tested and approved for use with wood pellets ONLY. Burning of any other fuel will void your warranty.

### WARNING

**BURNING COLORED PAPER, CARDBOARD, SOLVENTS, TRASH AND GARBAGE OR ALTERING THE STOVE FOR HIGHER HEAT OUTPUT MAY CAUSE DAMAGE TO THE STOVE AND COULD RESULT IN A HOUSE FIRE. USE ONLY APPROVED FUELS AND FOLLOW ONLY THESE OPERATION GUIDELINES.**

### WARNING

**NEVER USE GASOLINE, GASOLINE-TYPE LANTERN FUEL, KEROSENE, CHARCOAL LIGHTER FLUID, OR SIMILAR LIQUIDS TO START OR 'FRESHEN UP' A FIRE IN THIS HEATER. KEEP ALL SUCH LIQUIDS WELL AWAY FROM THE HEATER, WHILE IN USE.**

### WARNING

*Tested and approved for use with wood pellets ONLY. Burning of any other fuel will void your warranty.*

## I. Quick Start Guide

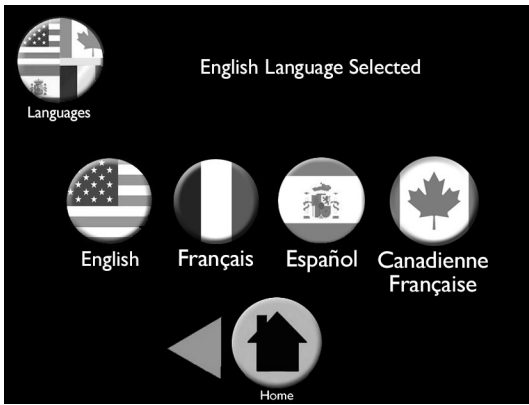

### Initial start-up Only

1. Select Language



2. Fill hopper with pellets



3. Adjust arrows to set room desired temperature.

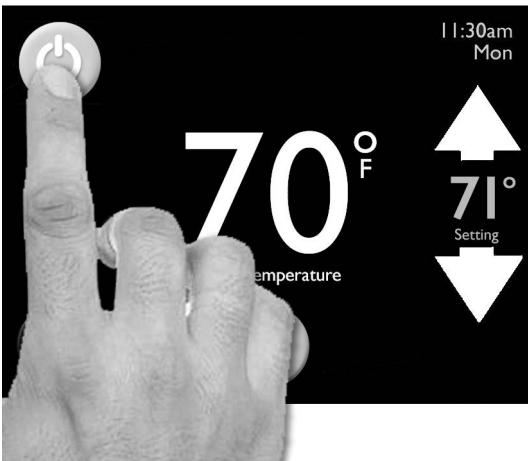

4. Touch the On/Off Power Icon.

*Refer to Touch Manual for all other operations.*

**Please Note:** The USB port on the EASY Touch Control is not a charging port for smartphones, tablets etc.



## J. Frequently Asked Questions







With proper installation, operation, and maintenance your appliance will provide years of trouble-free service. If you do experience a problem, this troubleshooting guide will assist a qualified service person in the diagnosis of a problem and the corrective action to be taken.

**Contact your dealer for additional information regarding operation and troubleshooting. Visit [www.harmanstoves.com](http://www.harmanstoves.com) to find a dealer.**

ISSUES	SOLUTIONS
Metallic noise.	Noise is caused by metal expanding and contracting as it heats up and cools down, similar to the sound produced by a furnace or heating duct. This noise does not affect the operation or longevity of your appliance.
White ash buildup on glass.	This is normal. Clean the glass using any non-abrasive glass cleaner.
Glass has buildup of black soot.	Excessive build-up of ash. The lower burn settings will produce more ash, the higher burn settings produce less. The more it burns on low the more frequent cleaning of the glass is required.
Glass has turned dirty.	Excessive build up of ash. The lower burn settings will produce more ash, the higher burn settings produce less. The more it burns on low the more frequent cleaning of the glass is required.
Fire has tall flames with black tails and is lazy.	The feed rate needs to be reduced or the burnpot needs cleaning. Heat exchanger or exhaust blower needs cleaning.
Smoky start-up or puffs of smoke from the airwash.	Burnpot may be dirty, clean the burnpot.
Large flame at start-up.	This is normal. Flame will settle down once the fire is established.
Missed Ignition.	<p>Ensure pellets in burnpot</p> <p>Ensure holes in burnpot are clear of obstructions above the igniter. See Burnpot Maintenance.</p> <p>Check to see if the ignitor is getting hot, if not replace ignitor.</p> <p>*See manual ignition instructions for emergency heating needs.</p>

## . Cleaning Prompts, Messages and Errors

Your EASY Touch Control communicates with you by showing messages on the top center of the EASY Touch Control home screen. If you have more than one message, the messages will show consecutively until you acknowledge the message by performing the task and reset. These communications include:

<b>PROMPTS</b>	Scrape Burn Pot and Reset Here 	When prompted, scrape burnpot. Press checkmark to reset.
	Empty Ash Pan and Press Here 	When prompted, inspect and empty ash pan as needed. Press checkmark to reset.
	Total Clean and Reset 	When prompted, inspect and perform total clean. Press checkmark to reset.
<b>MESSAGES</b>	Touch Here If Hopper Was Filled 	Press checkmark if you filled the hopper. If you did not fill hopper, The message will disappear in 30 seconds.
	Wireless Sensor Low Battery Warning	Replace the 2 "AA" batteries in the Wireless Remote Sensor.
	Using Backup Sensor	If Wireless Remote Sensor batteries die, the Back Up Sensor will continue to heat your home.
<b>ERRORS</b>	Warning: Door Open	Check and close the front and ash doors for the stove to continue to heat.
	Warning: Hopper Lid Open	Close the hopper lid for the stove to continue to heat.
	Error: Check Fuel and Reset 	Fill the hopper with pellets. Press checkmark to reset. If you did not fill the hopper, the message will stop after 30 seconds. This error only appears if "Show Fuel Gauges" is turned on.
	Wireless Signal Lost Replace Batteries in Wireless Sensor	Batteries in Wireless Remote Sensor have expired. Replace the 2 "AA" batteries.
	Return Air Sensor Failure	Return Air Sensor has failed. Call your Harman Dealer.
	Ignition Failure Correct and Reset 	Unit has failed to ignite. Scrape the burnpot. Call your Harman Dealer if problem persists.
	Connection Failure Control <====> Display	Touch Control has lost communication to the stove. Call your Harman Dealer.
	Exhaust Sensing Probe Failure	Exhaust Sensing Probe (ESP) as failed. Clean the ESP. If issue persists, call your Harman Dealer.
	Combustion Error Correct and Reset 	Clean your stove. Call your Harman Dealer if problem persists.

## 2 Maintenance and Service

When properly maintained, your stove will give you many years of trouble-free service. **Contact your dealer** to answer questions regarding proper operation, trouble-shooting and service for your appliance. Visit [www.harmanstoves.com](http://www.harmanstoves.com) to find a dealer. We recommend annual service by a qualified service technician.

**Note:** Do not use a household vacuum to clean the stove. We recommend that you use a shop vacuum that is equipped with a fine dust filter called a HEPA filter or a vacuum specially made for fly ash and soot. **USING A VACUUM WHICH IS NOT EQUIPPED WITH A FINE DUST FILTER WILL BLOW FLY ASH AND SOOT OUT INTO THE ROOM.**

**NOTE:** THE STOVE MUST BE COMPLETELY OUT BEFORE YOU VACUUM THE STOVE. LIVE PELLET EMBERS, IF SUCKED INTO THE VACUUM, WILL LIGHT THE VACUUM ON FIRE AND MAY ULTIMATELY CAUSE A HOUSE FIRE.

### NOTICE

The type of fuel you are burning will dictate how often you have to clean your burnpot. Clean more frequently if you encounter heavy build-up of ash at the recommended interval or you see soot coming from the vent. ***Not properly cleaning your appliance on a regular basis will void your warranty.***

### A. Proper Shutdown Procedure

#### CAUTION



#### Shock and Smoke Hazard

- Turn unit to the off position, let appliance completely cool and combustion fan must be off. Now you can unplug appliance before servicing.
- Smoke spillage into room can occur if appliance is not cool before unplugging.
- Risk of shock if appliance not unplugged before servicing appliance.

**Follow the detailed instructions found in this section for each step listed in the chart below.**

## B. Quick Reference Maintenance Chart

Frequency	Cleaning Procedure	Safety Measures	Tips
Daily	Scrape Burn pot	Wear flame resistant gloves <sup>3</sup>	Vigorous, strong scraping specifically near neck of burn pot. Scrape every time you add pellets or at least every 3 bags of fuel. <sup>2</sup>
Weekly	Empty Ash Pan	Wear protective gloves. <sup>1</sup> Put ashes into a steel non-combustible container with tight fitting lid outside.	Unit does not need to be turned off. Reduce to low burn during removal.
	Clean the Glass	Stove must be turned off and cold.	
Monthly	Scrape & Vacuum Heat Exchanger	Stove must be turned off and cold.	Use provided scraper. Scrape back and sides of firebox.
	Brush & vacuum the distribution fan	Stove must be turned off, cold and unplugged from power supply.	Use provided paint brush. This should be done approximately every 25 bags. <sup>2</sup>
	Inspect Hopper lid gasket for damage		Replace gasketing if frays, tears or other visible damage to gasket. This should be done approximately every 50 bags. <sup>2</sup>
	Clean Igniter	Stove must be turned off, cold and unplugged from power supply. Wear protective gloves. <sup>1</sup> Put ashes into a steel non-combustible container with tight fitting lid outside.	Use provided paint brush. Vacuum loose ash from around igniter and inside burn pot.
<b>Stove MUST be turned off, cold and unplugged from power supply for Yearly Cleaning.</b>			
Yearly <sup>4</sup>	Brush & vacuum the combustion fan and venting/exhaust path	Wear protective gloves. <sup>1</sup> Put ashes into a steel non-combustible container with tight fitting lid outside.	Use provided paint brush to brush fan blades. *Use flue brush to clean venting being careful not to damage the ESP. <sup>2</sup>
	Inspect door gasket		Replace gasketing if frays, tears or other visible damage to gasket.
	Brush & vacuum venting system	Wear protective gloves. <sup>1</sup> Put ashes into a steel non-combustible container with tight fitting lid outside.	

\* A flue brush of appropriate size and length may need to be purchased for proper maintenance.

1. Protective gloves will help prevent skin abrasion while working on steel surfaces.
2. Frequency of cleaning depends largely on fuel type. Lower quality pellets require most frequent cleaning.
3. Flame resistant gloves will help protect your skin from potential contact with heat or flames.
4. Yearly cleaning is also known as a Total Clean. This requires completing all the Daily, Weekly, Monthly and Yearly maintenance mentioned. This should be done before you begin burning the unit each heating season.

## C. Unit Maintenance

**Daily/Weekly Maintenance:** It is recommend that the burn pot be scraped whenever adding fuel; taking the opportunity to clean the burn pot will insure proper daily operation.

### Scraping the Burn Pot-

- Using flame resistant gloves, vigorously scrape the top holed surface and sides of the burn pot down to auger tube, be sure to concentrate in the neck of the burnpot. Figure 2.1.
- Scrape loosened material over edge of burnpot grate into the ashpan.
- If needed, empty the ash pan while adding fuel and after scraping the burn pot.

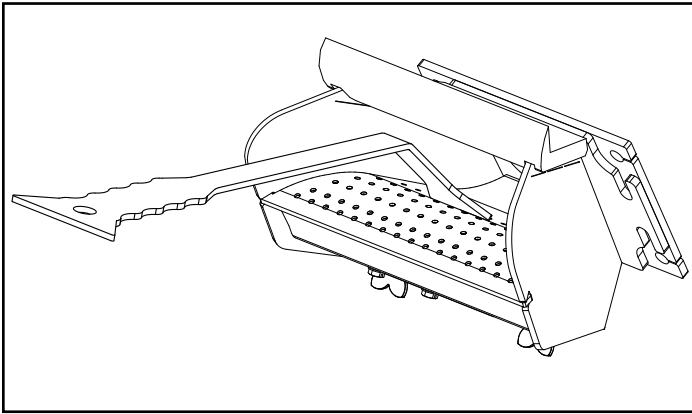

Figure 2.1

**Monthly Maintenance:** It is recommend that the unit be shut down and unplugged from any power source for a monthly cleaning. Monthly cleanings will insure proper operation of your unit throughout the heating season.

- Cleaning Glass - Once unit is cold, use a non-abrasive glass cleaner on glass and wipe clean.
- Scrape and Vacuum Heat Exchanger.

### Cleaning the Heat Exchanger-

Clean the heat exchanger with scraper as shown in Figure 2.2. Brush or scrape the inside of the stove to remove fly ash. Remove the ash pan and dispose of ashes in an approved manner, according to local codes.

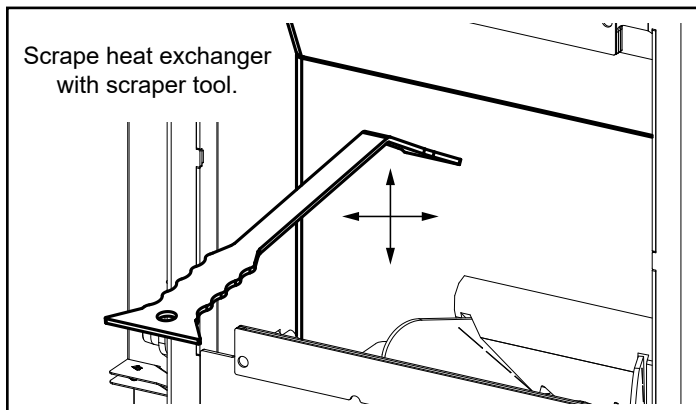

Figure 2.2

### Cleaning the Burn Pot-

- Vigorously scrape the top holed surface and sides of the burn pot down to auger tube, as suggested in the Daily/Weekly Maintenance Section.
- Use the supplied allen wrench to remove any build-up that may have accumulated in the holes of the burn pot grate. Simply push the allen wrench down through each hole ensuring it is clear of any build-up paying attention not to damage the igniter element in the process. Figure 2.3.

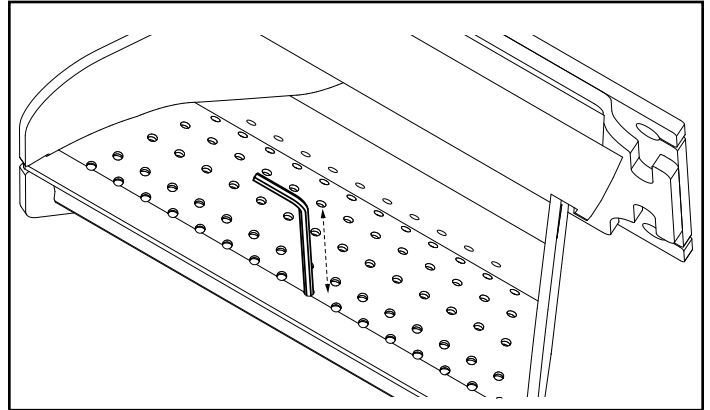

Figure 2.3



**DANGER**

**Disconnect the power to the unit before removing cover.**

- Loosen the (2) wing thumb screws on the lower front angle of the burn pot. Figure 2.4

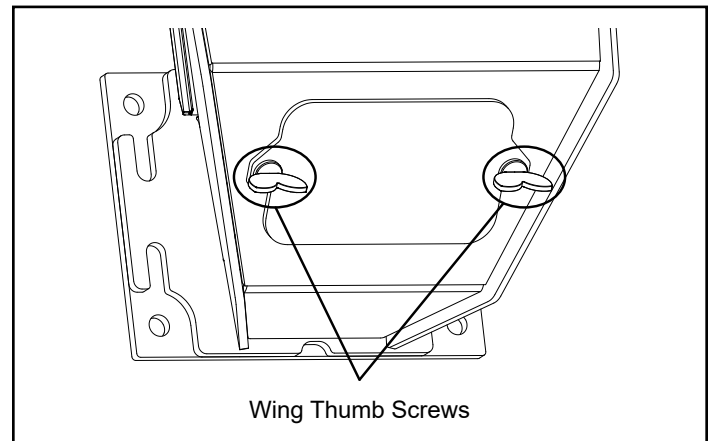

Figure 2.4

- Lift off the clean-out cover to open the bottom clean-out chamber. Figure 2.5
- Clean ash buildup from inside the chamber while cover is off. Use the scraper to tap on the top front edge of the burn pot. This will help knock pieces of ash, loosened by the scraping process, down through the holes. It also helps knock ash buildup from the igniter element and bracket.

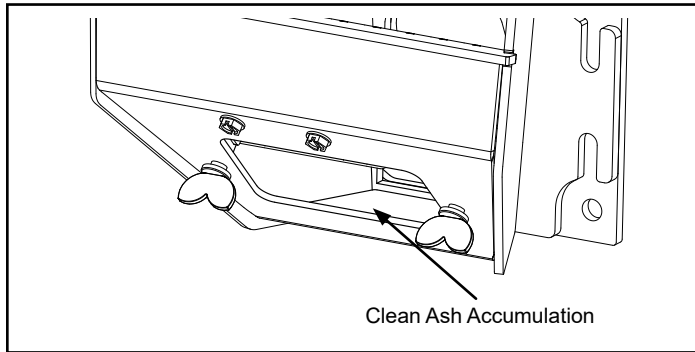

Figure 2.5

### Cleaning Igniter Bracket-

Check cleanliness of the igniter and inner burnpot. If the igniter has ash buildup it must be removed to insure proper ignition. Use the provided brush to remove ash buildup from in and around the igniter. Once ash is loose vacuum around igniter and at the base of burn pot. Figure 2.6.

**⚠ WARNING**

**Use caution when cleaning burn pot clean-out chamber. Do not damage the high temperature igniter wires.**

**Note: The hot lead/cold lead connection must always be pulled to the rear of the feeder body before operation.**

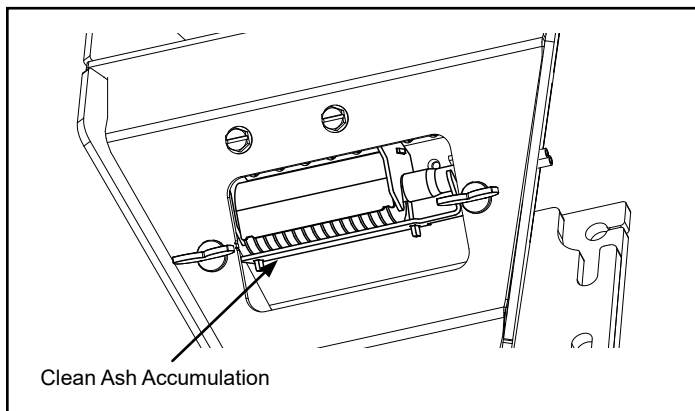

Figure 2.6

### Yearly Maintenance: Cleaning the Combustion Fan Chamber-

The combustion inlet cover is located behind the ash pan that must be removed to properly clean the combustion fan blade. Figure 2.7.

- Remove combustion inlet cover by pulling up on cover. This allows access to the combustion fan blade and exhaust path. Figure 2.7.
- Remove any flyash or debris that has collected around combustion fan blade with the provided paint brush.

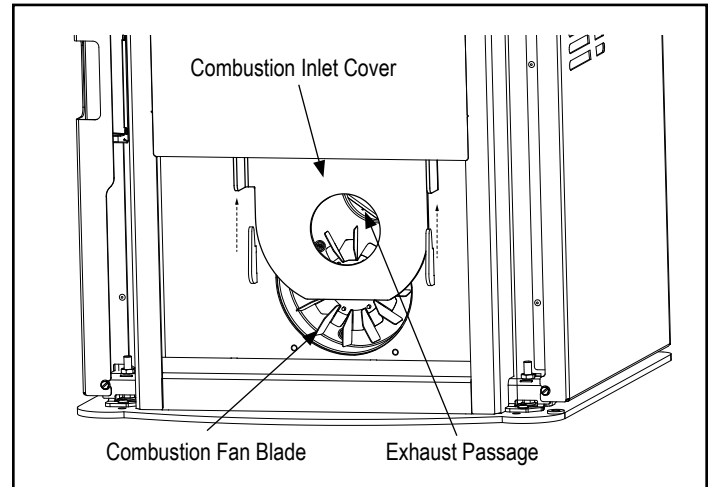

Figure 2.7

- Clean exhaust passage. Figure 2.8.

**NOTE: The ESP Sensor is located just inside the exhaust passage. Be sure not to damage the ESP Sensor while cleaning the exhaust passage.**

- Once cleaned replace combustion inlet cover and ashpan.

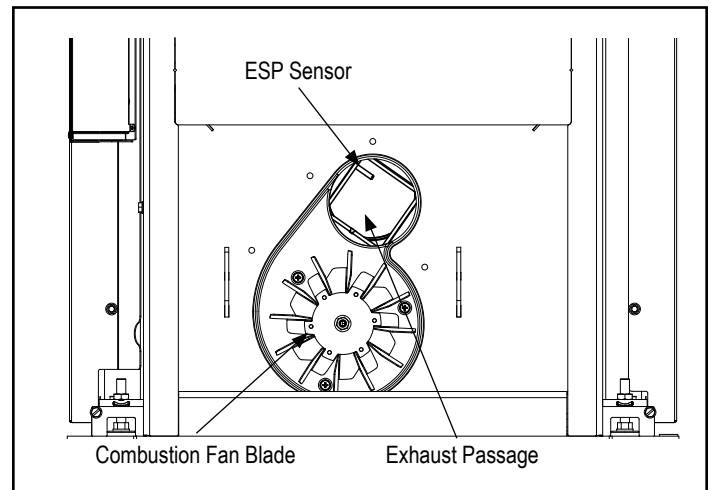

Figure 2.8

## Caring for your Glass-

The glass used in your stove is manufactured to exact standards to withstand the high heat of the fire, but like all glass, it must be treated with common sense and care. Never abuse the glass by slamming the door shut or striking the glass with a heavy object. If the glass is broken or damaged, do not operate the stove until it has been replaced.

### Glass - Replacement:

If the stove's glass is cracked or broken, you must replace it before operating your stove. Remove pieces carefully. Replace glass only with Harman® replacement glass; **do not use substitutes.**

Carefully remove damaged glass, gasket material, and glass clips (set aside). Figure 2.9.

Install the self adhesive 1/4" gasket material around the front face of the glass. Set the glass panel and gasket gently onto the door. Install the glass clips and 1/4-20 X 3/8" screws. **Note:** 1/4-20 X 3/8" screws only need to be snug fit. Do not overtighten.

### Glass - Cleaning:

Sometimes it will be necessary to clean accumulated ash from the glass surface; allowing this ash to remain on the glass for long periods can result in "etching" due to the acidity of the ash. Never clean the glass while it is hot, and **do not** use abrasive substances. Wash the surface with cool water and rinse thoroughly. You may wish to use a non-abrasive cleaner specifically designed for use on stove glass. In any case, dry thoroughly before relighting your stove.

### Inspect all Gaskets-

While the unit is cool, inspect all door gaskets to insure proper seal. The gasket should be continuous without frays or tears; having plyable gasket means having a correct seal for proper operation. Figure 2.9.

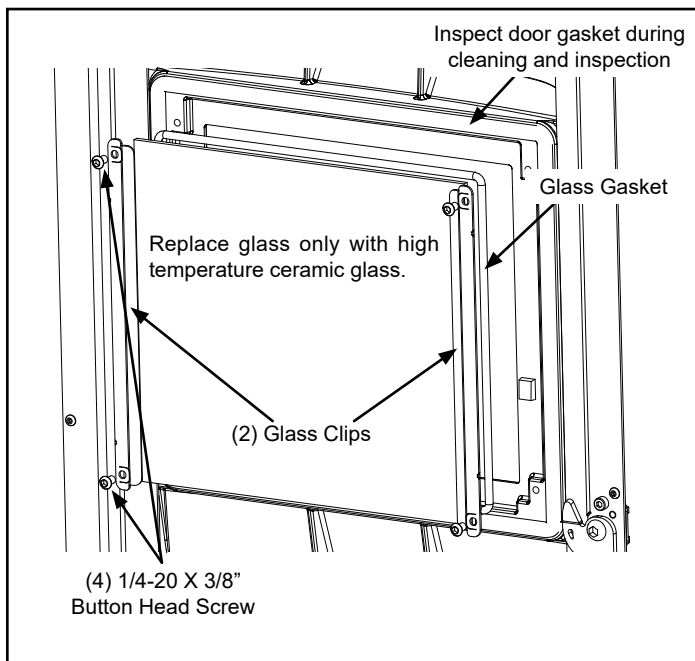

Figure 2.9

## Distribution Blower-

Checking the distribution blowers yearly is a good habit to get into. Dust, animal hair or anything else that can make its way into that area can drastically cut down on the air movement throughout the unit ultimately causing less of a heating efficiency.

Once the unit is shut down and cooled, unplug the unit from its power supply. Remove the left and right rear panels. Once removed, you will have access to the distribution blowers. Figure 2.10.

Once access is gained to the rear of the unit, thoroughly vacuum around the Distribution Blowers. Figure 2.10.

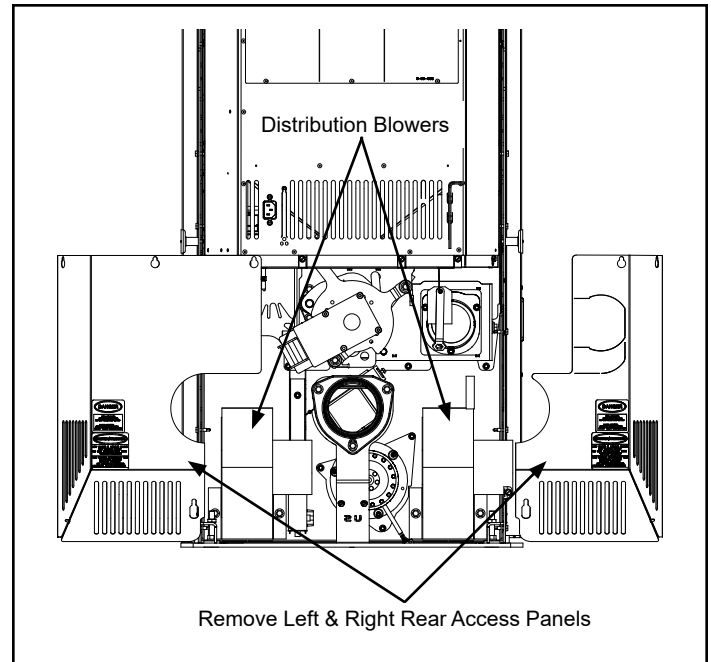

Figure 2.10

## Cleaning Venting System-

Its is recommend that a certified chimney sweep perform service and inspection to your chimney system to insure your unit is vented safely and in accordance to local code.

# 3 Reference Material

## A. Service Parts



Service Parts

Allure50

Pellet Stove

Beginning Manufacturing Date: Aug 2016

Ending Manufacturing Date: Active

1-90-888000-1(Black) (Beginning Manufacturing Date: Aug 2016)(Ending Manufacturing Date: Feb 2020)

1-90-888001-1(Black w/Wireless) (Beginning Manufacturing Date: Feb 2020)

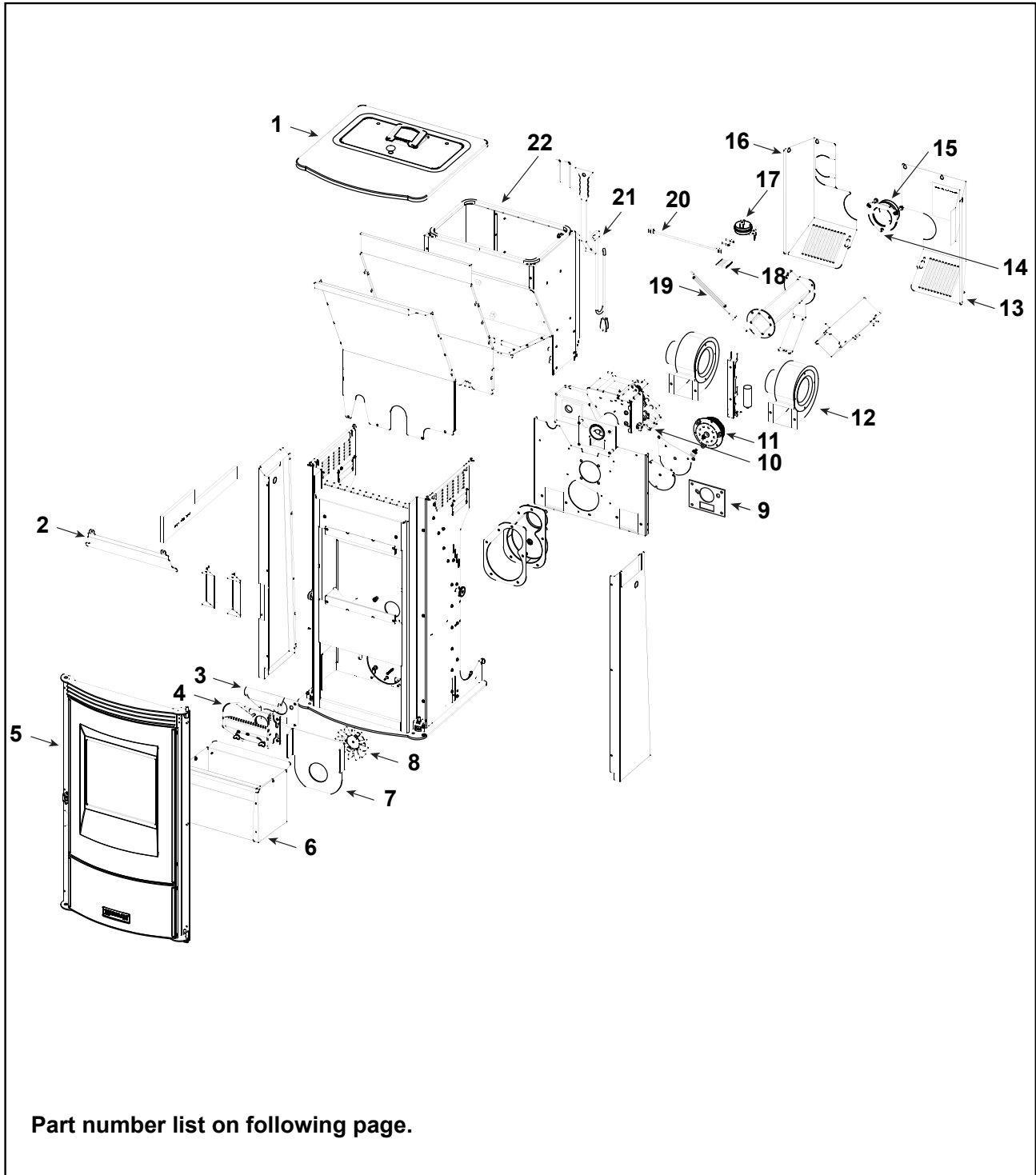



IMPORTANT: THIS IS DATED INFORMATION. Parts must be ordered from a dealer or distributor. **Hearth and Home Technologies does not sell directly to consumers.** Provide model number and serial number when requesting service parts from your dealer or distributor.



Stocked at Depot

ITEM	DESCRIPTION	COMMENTS	PART NUMBER	
1	Top Assembly		See following Page	
2	Smoke Shield		1-00-888116	
3	Flame Guide		3-00-06644	Y
4	Burn Pot Assembly		See following Page	
5	Door Assembly		See following Page	
6	Ash Pan		1-10-888168A	Y
	Ash Pan Parts		1-00-888274	
7	Inlet Cover		1-10-888158	
8	Fan Blade		1-10-574500A	Y
9	Gasket Set, Burn Pot & Tailpipe	Pkg of 5 Sets	1-00-07381	Y
10	Feeder Assembly		See following Page	
11	Combustion Blower & Capacitor		1-00-02275	Y
	Capacitor		1-00-00276	Y
	Blower Mounting Studs and Nuts	5 Sets	1-00-832150	
12	Distribution Blower	Qty 2 req	3-21-33647	Y
13	Rear Cover, Right	Pre HF1572862	1-10-888124A	Y
		Post HF1572862	SRV8888-010	Y
14	Gasket Set, Burn Pot & Tailpipe	Pkg of 5 Sets	1-00-07381	Y
15	Tailpipe, Cast		3-00-247237	Y
16	Rear Cover, Left	Pre HF1572862	1-10-888123A	Y
		Post HF1572862	SRV8600-001	Y
17	Differential Switch		SRV8320-003	Y
	Tubing, 1/8" Silicone	5 Feet	1-00-5113574	Y
18	Wiring Harness		3-20-08888	Y
19	ESP Probe		3-20-00844	Y
20	Communication Cable		3-20-72662	Y
21	Power Cord		3-20-51578	Y
	Line Filter		3-20-803744	Y
22	Hopper Assembly w/Rear Covers	No longer available	SRV8787-008	
		No longer available	SRV1-10-888223	
	Gasket, Hopper Throat		3-44-677185	Y
	Gasket 3/8 x 1/2	20 Feet	1-00-375501	Y
	Wireless Room Sensor		3-20-777556	Y

Additional service parts on following page.

IMPORTANT: THIS IS DATED INFORMATION. Parts must be ordered from a dealer or distributor. **Hearth and Home Technologies does not sell directly to consumers.** Provide model number and serial number when requesting service parts from your dealer or distributor.



Stocked at Depot

ITEM	DESCRIPTION	COMMENTS	PART NUMBER	
<p><b>#1 Top Assembly</b></p>				
1.1	Touch Control		1-00-777552	Y
	Cable Cover Gasket	Post HF1571168	3-44-777549	
1.2	Black Knob w/Screw		1-00-02000-1	
1.3	Complete Latch	2 Sets	1-00-0669697	Y
1.4	Gasket, 3/8 x 1/2	20 Feet	1-00-375501	
1.5	Ball Plunger 5/16 x 1/2	Pkg of 3	3-31-5500-3	
1.6	Push Retainer 5/16	Pkg of 100	3-31-94807-100	
1.7	Hinge w/Hardware		1-00-777771	Y
1.8	Hinge Pin Plates w/Hardware	1 Set	1-00-777560	
1.9	Cast Top		4-00-888106S	
1.10	Hopper Lid Glass 16 x 8		3-40-777770	Y
1.11	Screwposts/Washers	Pkg of 20 Sets	1-00-129004	Y
<p><b>#4 Burn Pot Assembly</b></p>				
4.1	Igniter Cradle Kit		1-00-777907	Y
4.2	Wingscrews 1/4-20 x 5/8	Pkg of 10	3-31-782108-10	Y
4.3	Cleanout w/Hardware	Set of 2	1-00-06623	Y
4.4	Igniter		3-20-677200	Y
		Pkg of 10	1-00-677200	Y
4.5	Burn Pot Weldment		1-10-888194W	Y

Additional service parts on following page.

IMPORTANT: THIS IS DATED INFORMATION. Parts must be ordered from a dealer or distributor. **Hearth and Home Technologies does not sell directly to consumers.** Provide model number and serial number when requesting service parts from your dealer or distributor.



**Stocked at Depot**

ITEM	DESCRIPTION	COMMENTS	PART NUMBER
------	-------------	----------	-------------

### #5 Door Assembly

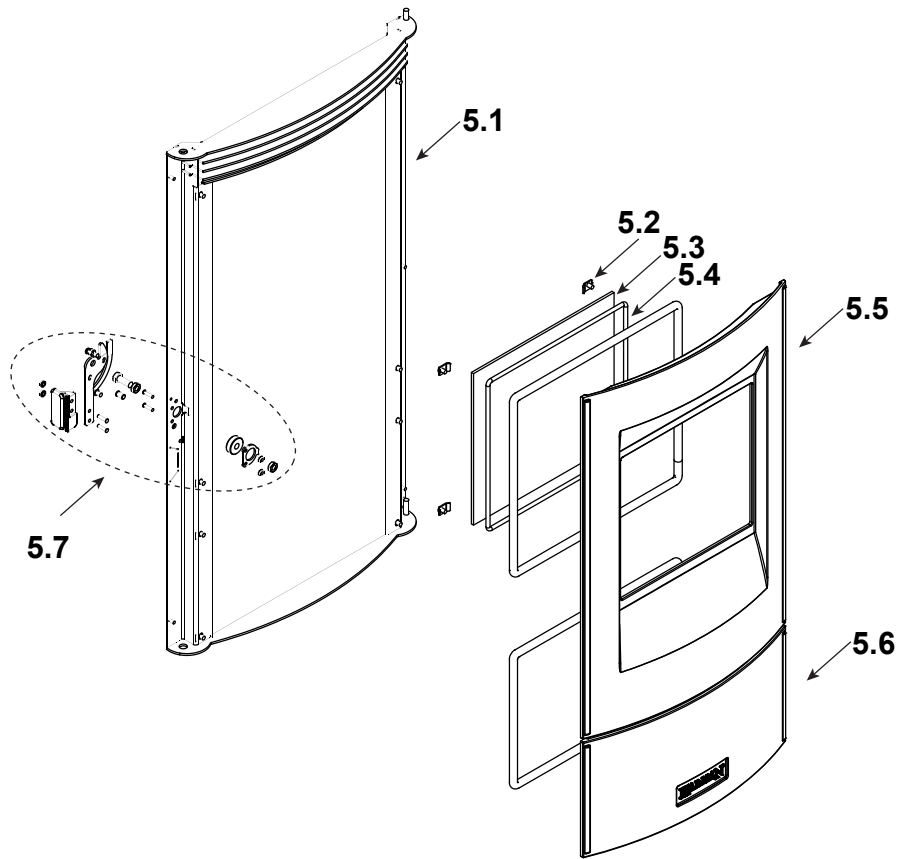

5.1	Front Weldment		1-10-888515W	
5.2	Glass Clips	Pkg of 4	SRV8000-031	Y
5.3	Glass w/Gasket		1-00-888150	Y
5.4	Gasket, 1/4" RD PSA	15 Feet	1-00-2312	Y
5.5	Load Door, Roped		4-00-888108S	Y
	Gasket, 1/2" Round Graphite	20 Feet	1-00-1086415	Y
5.6	Ash Door, Roped		4-00-888109S	Y
	Gasket, 1/2" Round Graphite	20 Feet	1-00-1086415	Y
5.7	Latch Kit		1-00-888136	Y
	Latch Roller w/Hardware		1-00-888210	
	Wave Washer	Pkg of 10	SRV3-31-453013	

Additional service parts on following page.

IMPORTANT: THIS IS DATED INFORMATION. Parts must be ordered from a dealer or distributor. **Hearth and Home Technologies does not sell directly to consumers.** Provide model number and serial number when requesting service parts from your dealer or distributor.



Stocked at Depot

ITEM	DESCRIPTION	COMMENTS	PART NUMBER	
<p><b>#10 Feeder Assembly</b></p>				
10.1	Feeder Body		1-10-777513A	Y
10.2	Slide Plate		1-10-777690A	Y
10.3	Feed Cover & Gasket	2 Sets	1-00-677122	Y
10.4	Pusher Arm		1-10-888539W	Y
	Pillow Block	Pkg of 4	3-31-3614087-4	Y
10.5	Auger		3-50-00565	Y
	Gasket, Auger	Pkg of 5	1-00-888196	
10.6	Bearing Retainer w/Hardware		1-00-04035	Y
	Cam Bearing		3-31-3014	Y
10.7	Cam Block Assembly		1-10-777950A	Y
10.8	Gear Motor		3-20-00677	Y
10.9	Motor Mount w/Hardware		1-00-777598	Y
10.10	Feeder Crossover Tube Kit		1-00-67900	Y
10.11	Gasket, Snout	Pkg of 10	3-44-677160-10	Y
10.12	Air Intake		1-10-06810A	
10.13	Gasket, Air Intake	Pkg of 6	3-44-72224-6	Y
<p><b>#23 Control Board</b></p>				
23	Control Board		1-00-05372	Y
	5A Ceramic Fuse	Pkg of 5	1-00-05237	Y

Additional service parts on following page.

IMPORTANT: THIS IS DATED INFORMATION. Parts must be ordered from a dealer or distributor. **Hearth and Home Technologies does not sell directly to consumers.** Provide model number and serial number when requesting service parts from your dealer or distributor.



Stocked at Depot

ITEM	DESCRIPTION	COMMENTS	PART NUMBER	
	Burn Pot Scraper	Pkg of 10	2-00-777692-10	
	Side Panel, Left	Brushed Stainless	1-00-88857-6	
		Gloss Black	1-00-88857-26	
		Gloss White	1-00-88857-28	
		Gloss Red	1-00-88857-29	
		Satin Black	1-00-88857-1	
	Side Panel, Right	Brushed Stainless	1-00-88877-6	
		Gloss Black	1-00-88877-26	
		Gloss White	1-00-88877-28	
		Gloss Red	1-00-88877-29	
		Satin Black	1-00-88877-1	
	Column, Left, Narrow	Brushed Stainless	1-00-88856-6	
		Gloss Black	1-00-88856-26	
		Gloss White	1-00-88856-28	
		Gloss Red	1-00-88856-29	
	Column, Right, Narrow	Brushed Stainless	1-00-88876-6	
		Gloss Black	1-00-88876-26	
		Gloss White	1-00-88876-28	
		Gloss Red	1-00-88876-29	
	Column, Left, Wide	Satin Black	1-00-88859-1	
	Column, Right, Wide	Satin Black	1-00-88879-1	
	Curved Glass		1-00-888151	
	Draft Meter Assembly		1-00-00637	
	Draft Meter Bolt & Tube		1-00-04004	
	Leg Leveling Kit	1 Set	1-00-12302	
	Return Air Sensor		3-20-08780	
	Tinnerman 10-24	Pkg of 25	SRV3-31-00177	
	Touch-up Paint	Gloss Black	1-00-0026	
		Gloss White	1-00-0028	
		Gloss Red	1-00-0029	
		Satin Black	1-00-0001	

## B. Limited Lifetime Warranty

### Hearth & Home Technologies LLC

#### LIMITED WARRANTY

Hearth & Home Technologies LLC (“HHT”) extends the following warranty for HHT gas, wood, pellet and electric hearth appliances (each a “Product” and collectively, the “Product(s)”) and certain component parts set forth in the table below (“Component Part(s)”) that are purchased from a HHT authorized dealer or distributor.

#### **WARRANTY COVERAGE:**

HHT warrants that the Products and their Component Parts will be free from defects in materials and workmanship for the applicable period of Warranty coverage set forth in the table below (“Warranty Period”). If a Product or Component Parts are found to be defective in materials or workmanship during the applicable Warranty Period, HHT will, at our discretion, repair the applicable Component Part(s), replace the applicable Component Part(s), or refund the purchase price of the applicable Product(s). The maximum amount recoverable under this Warranty is limited to the purchase price of the Product. This Warranty is transferable from the original purchaser to subsequent owners, but the Warranty Period will not be extended in duration or expanded in coverage for any such transfer. This Warranty is subject to conditions, exclusions, and limitations as described below.

#### **WARRANTY PERIOD:**

Warranty coverage begins at the date of installation. In the case of new home constructions, Warranty coverage begins six months after invoice of the final sale of the Product(s) by an independent, authorized HHT dealer or distributor. However, the Warranty coverage shall commence no later than 24 months following the date of Product shipment from HHT, regardless of the installation or purchase date.

Warranty Period		HHT Manufactured Appliances and Venting					
Component Parts	Labor	Gas	Pellet	Wood	Electric	Component Parts Covered by this Warranty	
1 Year		X	X	X		All parts including handles, external enameled components and other material except as covered by Warranty Conditions, Warranty Exclusions, and Warranty Limitations listed	
2 Years					X	All parts except as covered by Warranty Conditions, Warranty Exclusions, and Warranty Limitations listed	
			X	X		Glass, Electrical components limited to heating element/igniters, Top feed auger assembly, Blowers, Junction Box, Remotes/Wall switches, linear actuator, power cord, vacuum switch, snap disc, wire harnesses and thermocouple	
		X				Electrical components limited to modules, remotes/wall switches, valves, pilots, blowers, junction boxes, wire harnesses, transformers and lights (excluding light bulbs)	
		X		X		Cement Refractory Panels, Glass Liner Panels	
3 years			X			Firepots, bumpots, Harman mechanical feeders	
5 years		X		X		Catalysts, Vented and Vent Free burners and logs	
10 years	1 year	X				Burners, logs and metal/fiber refractory components of HHT manufactured fireplaces or stoves, venting due to poor workmanship	
10 years	3 years		X	X		Castings, Medallions & Baffles, FlexBurn® System (engine, inner cover, access cover and fireback), Firebox and heat exchanger, HHT Chimney & Terminations, Manifolds	
20 years	3 years	X				Firebox and heat exchanger	
<b>All purchased replacement parts and optional accessories</b>							
1 Year	None	X	X	X	X	All purchased replacement parts and optional accessories	

## **WARRANTY CONDITIONS:**

- Because HHT cannot control the quality of any Products sold by unauthorized sellers, this Warranty only covers Products that are purchased through an HHT authorized dealer or distributor unless otherwise prohibited by law; a list of HHT authorized dealers is available on the HHT branded websites.
- This Warranty is only valid while the applicable Product remains at the site of original installation.
- This Warranty is only valid in the country in which the HHT authorized dealer or distributor that sold the applicable Product is authorized to sell applicable Product.
- Contact your installing distributor or dealer for Warranty service. If the installing dealer or distributor is unable to provide necessary parts, contact the nearest HHT authorized dealer or supplier. Additional service fees may apply if you are seeking Warranty service from a dealer other than the dealer from whom you originally purchased the applicable Product.
- No HHT consumer should bear cost of warranty service or costs incurred while servicing warranty claims (i.e., travel, gas, or mileage) when the service is performed within the terms of this Warranty. Check with your dealer or distributor in advance for any costs to you when arranging a warranty call. Travel and shipping charges for parts are not covered by this Warranty.

## **WARRANTY EXCLUSIONS:**

This Warranty does not cover the following:

- Changes in surface finishes as a result of normal use. As a heating appliance, some changes in color of interior and exterior surface finishes may occur. This is not a flaw and is not covered under the Warranty.
- Damage to printed, plated, or enameled surfaces caused by fingerprints, accidents, misuse, scratches, melted items or other external sources and residues left on the plated surfaces from the use of abrasive cleaners or polishes.
- Repair or replacement of parts that are subject to normal wear and tear during the Warranty Period are not covered. These parts include: paint, wood and pellet gaskets, firebricks, wood grates, flame guides, batteries and the discoloration of glass.
- Minor expansion, contraction, or movement of certain parts causing noise. These conditions are normal and complaints related to this noise are not covered by this Warranty.
- Damages resulting from: (1) failure to install, operate, or maintain the applicable Product in accordance with the installation instructions, operating instructions, and listing agent identification label furnished with the applicable Product; (2) failure to install the applicable Product in accordance with local building codes; (3) shipping or improper handling; (4) improper operation, abuse, misuse, continued operation with damaged, corroded or failed components, accident, or improperly/incorrectly performed repairs; (5) environmental conditions, inadequate ventilation, negative pressure, or drafting caused by tightly sealed constructions, insufficient make-up air supply, or handling devices such as exhaust fans or forced air furnaces or other such causes; (6) use of fuels other than those specified in the operation instructions; (7) installation or use of components not supplied with the applicable Product or any other components not expressly authorized and approved by HHT; (8) modification of the appliance not expressly authorized and approved by HHT in writing; and/or (9) interruptions or fluctuations of electrical power supply to the applicable Product.
- Non-HHT venting components, hearth connections or other accessories used in conjunction with the applicable Product.
- Any part of a pre-existing fireplace system in which an insert or a decorative gas applicable Product is installed.
- HHT's obligation under this Warranty does not extend to the Product's capability to heat the desired space. Information is provided to assist the consumer and the dealer in selecting the proper Product for the application. Consideration must be given to the Product location and configuration, environmental conditions, insulation and air tightness of the structure.

**This warranty is void if:**

- The applicable Product has been over-fired, operated in atmospheres contaminated by chlorine, fluorine, or other damaging chemicals. Over-firing can be identified by, but not limited to, warped plates or tubes, deformation/warping of interior cast iron structure or components, rust colored cast iron, bubbling, cracking and discoloration of steel or enamel finishes.
- The applicable Product is subjected to prolonged periods of dampness or condensation.
- There is any damage to the applicable Product due to water or weather damage which is the result of, but not limited to, improper chimney or venting installation.

## **LIMITATIONS OF REMEDIES AND LIABILITY:**

- **EXCEPT TO THE EXTENT PROVIDED BY LAW, HHT MAKES NO EXPRESS WARRANTIES OTHER THAN THE WARRANTY SPECIFIED HEREIN. The owner's exclusive remedy and HHT's sole obligation under this Warranty or in contract, tort or otherwise, shall be limited to, at HHT's sole option, replacement of the Component Part(s), repair of the Component Part(s), or refund of the original purchase price of the applicable Product(s). In no event will HHT be liable for any incidental or consequential damages caused by defects in the applicable Product. Some States do not allow the exclusion or limitation of incidental or consequential damages, so the above limitation or exclusion may not apply to you. This Warranty gives you specific legal rights and you may also have other rights which vary from State to State. THE DURATION OF ANY IMPLIED WARRANTY IS LIMITED TO DURATION OF THE EXPRESSED WARRANTY SPECIFIED ABOVE FOR THE APPLICABLE PRODUCT. Some States do not allow limitations on how long an implied warranty lasts, so the above limitation may not apply to you.**

## B. Loss of Power

Harman pellet burning appliances rely on a combustion blower to remove exhaust from the firebox. A power failure will cause the combustion blower to stop running, which may lead to exhaust see page into the room. Vertical rise in the venting system can help create natural draft, which may reduce the likelihood of exhaust leakage into the home.

Installation of a low-cost uninterruptible power supply (UPS) or battery backup system can help ensure the units shuts down without any minor smoke leakage into the home. Harman recommends the installation of one of these two systems for areas prone to power outages.

**There is one Harman® approved UPS option for your appliance:**

**Uninterruptible Power Supply UPS** battery back-ups are available online or at computer and office equipment stores. Your Harman® appliance with Rev E or later software available beginning in November 2010 may be plugged directly into a Harman® approved UPS:

- **TrippLite model INTERNET750U** is tested and approved. Other brands or models may not be compatible.

When power is lost, a fully charged UPS will power a safe, combustion blower only shut-down. Your appliance will pulse the blower every few seconds to clear exhaust until the fire is out. **NOTE: The UPS provides safe shut-down only. It is not intended for continued operation.**

- A Inverter/Charger connects to a 12 volt deep cycle battery that will run your appliance for up to eight (8) hours. It includes a trickle charge feature that keeps your battery charged when power is available. **NOTE:** If the power is out for longer than battery life, smoke leakage may still occur unless your stove has been safely shut down.

**For an approved Inverter/Charger refer to [www.harmanstoves.com](http://www.harmanstoves.com).**

Your appliance will recognize when power is restored. What happens depends on ESP temperature and whether it is equipped with automatic ignition:

- In **“Automatic” Mode**, units equipped with automatic ignition will respond to the set point and ESP temperature and resume normal operation.
- In **“Idle” Mode**, or for units without automatic ignition:
  - If the ESP is cool, the appliance will remain shut down.
  - If the fire is out and the ESP is still warm, the feeder may restart. Since the fire is out, the ESP temperature will not rise. The unit will then shut-down, and may flash a six-blink status error. (See ESP error codes)
  - If the fire is still burning, it will resume normal operation.

Contact your dealer if you have questions about UPS compatibility with your appliance.

**IMPORTANT!** : UPS or Battery Backup cannot prevent smoke leakage from an improperly maintained unit. Keep the venting system clean and free from obstructions and maintain all gaskets to keep an airtight seal.

### WARNING

**Use only Harman® approved battery back-up devices. Other products may not operate properly, can create unsafe conditions or damage your appliance.**

### CAUTION

**Always keep appliance doors and hopper lid closed and latched during operation and during power failures to minimize risk of smoke or burn-back.**

## D. Emergency Manual Ignition

Harman® pellet stoves and inserts should be lit using the automatic ignition system. This is the safest and most reliable way for igniting the unit. In the event the automatic igniter is not functioning, the steps below may be followed to manually light the stove or insert in the “Constant Burn” mode. Manual lighting is for emergency purposes only, and the igniter should be repaired or replaced as soon as practical.

### WARNING

Only use firestarter commercially marketed for pellet stoves and inserts, including wax coated wood chips, pellet starter gel and pellet igniter blocks. Use of any other type of firestarter is prohibited.

To avoid serious injury or death read and follow manufacturer’s warning and instructions for use of firestarter. Use of firestarter is only permitted when performing a cold start.

Never attempt to manually light a stove or insert that has been operated recently and is not at room temperature. If automatic ignition was attempted, be sure to give the stove or insert at least 30 minutes or longer to cool to room temperature.

Be sure that the stove or insert is in the “Igniter - Disabled” mode of operation.

Once all the precautions have been taken, follow these steps:

1. On the touch control, select the Burn Mode icon then select “Constant Burn”.
2. Arrow back and select the Igniter icon then select “Manual” for the ignition method. Select the Home Icon to go back to the Main Menu.
3. Fill burn pot with pellets, only half way. (Do Not Over Fill).
4. Add firestarter to pellets following manufacturer’s instructions.
5. Light firestarter with a match, and close the door, touch the On/Off icon on the home screen. Operation will begin when the fire reaches the proper temperature.



## E. Troubleshooting

ISSUES	SOLUTIONS
Stove does not feed	<ul style="list-style-type: none"> <li>• No fuel in hopper.</li> <li>• Firebox draft may be too low for sensing switch in feeder circuit to operate. <b>Check for closed doors</b>, loose or missing gasket on doors or hopper lid.</li> <li>• Feed motor will not run until the ESP control senses a certain temperature. Maybe you did not put enough fuel or firestarter in the burn pot before manually lighting the fire (In Constant Burn, Manual Light Only.)</li> <li>• Restriction in the hopper or feeder. Remove all fuel and examine. Clear the obstruction.</li> <li>• Feed motor has failed.</li> </ul>
Partially burned pellets	<ul style="list-style-type: none"> <li>• Feed rate too high.</li> <li>• Poor air to fuel mixture. (Check burn pot clean-out cover and air intake).</li> <li>• Burn pot may need to be cleaned.</li> <li>• Combination of all the above.</li> </ul>
Smoke smell	Seal the vent pipe joints and connection to stove with silicone. The exhaust vent is the only part of the system that is under positive pressure.
Fire has gone out	<ul style="list-style-type: none"> <li>• No fuel in hopper.</li> <li>• Draft is too low, blocked flue.</li> <li>• Something is restricting fuel flow.</li> <li>• Hopper lid not closed properly.</li> <li>• Feed motor or combustion fan has failed.</li> </ul>
Smoke is visible coming out of vent	<ul style="list-style-type: none"> <li>• Air-fuel ratio is too rich.               <ul style="list-style-type: none"> <li>- Feed rate too high.</li> <li>- Draft too low caused by a gasket leak.</li> </ul> </li> </ul>
Low heat output	<ul style="list-style-type: none"> <li>• Feed rate too low.</li> <li>• Draft too low because of gasket leak.</li> <li>• Poor quality or damp pellets.</li> <li>• Combination of 1 and 2.</li> </ul>

## F. Glass Installation and Cleaning

**Step 1 - Installing Side Panels:** Locate the cut-outs in the top of the panel that marry to the hooks located underneath the cast top. Once in place simply place the bottom of the panel flush against unit. Figure 1.

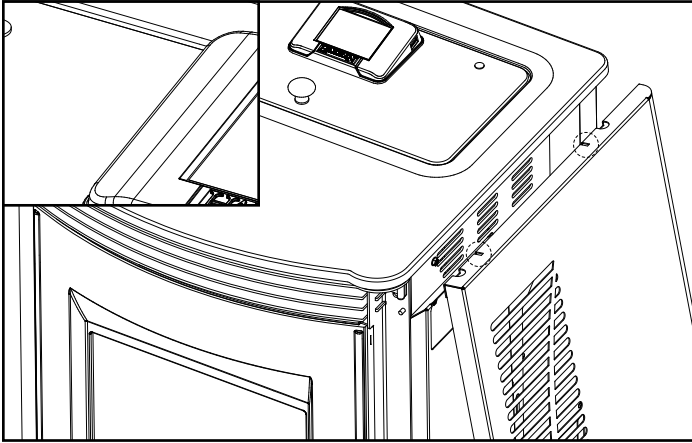

Figure 1

**Step 2:** Tighten the (4) 10-24 x 1/2" Thread cutting screw using a 5/16" nut driver, (2) Thread cutting screws per panel. Figure 2. **(Note: The door does not need to be removed to access screws.)**

**Helpful Hint;** When tightening the right panel front screw, open the door slowly until it contacts the side panel. This will push the side panel fully into the slot for tightening from the front.

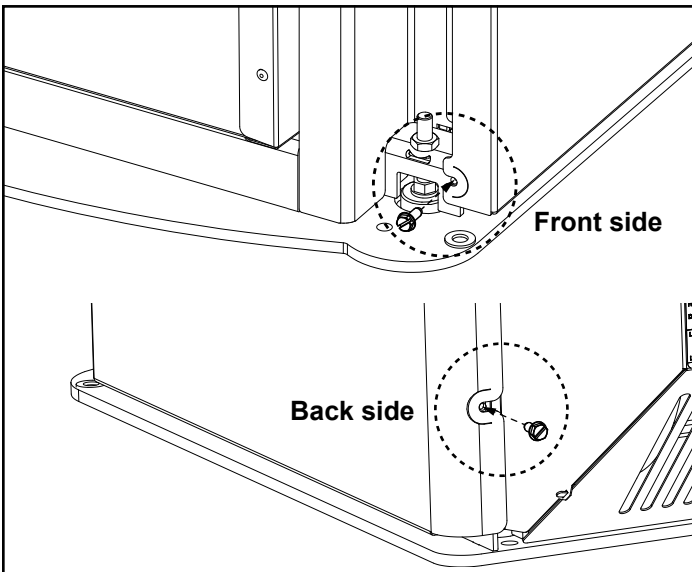

Figure 2

**Step 3 - Installing glass:** *If glass is not being installed move onto step 4.* Install right side column, do not tighten screws. Prior to installing glass make sure the end marked "Top" is up. Slide glass behind right hand column and push glass flush with door and center glass. Figure 3. Install the left column and tighten (3) 10-24 x 3/8" Button Head Screws at the top, center and bottom of the door, tighten right side column. Figure 4. **Note: Use 1/8" Allen Wrench supplied with stove.**

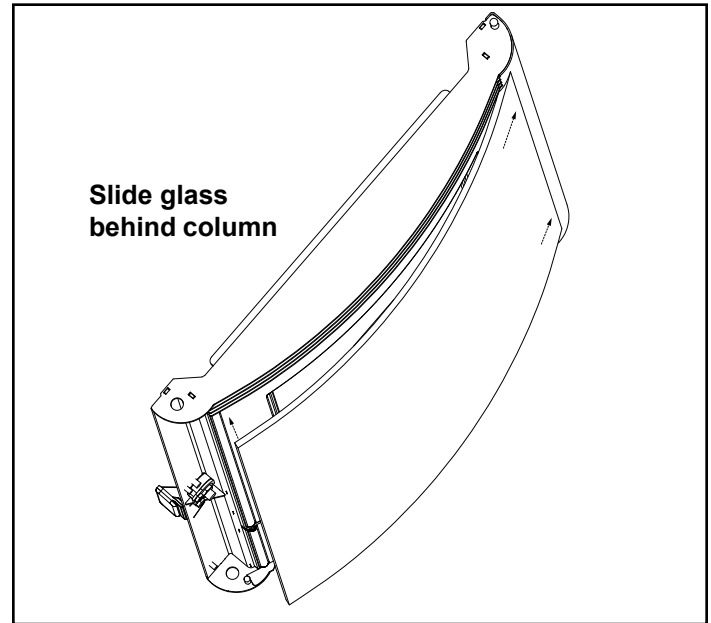

Figure 3

**Step 4 - Installing columns with no glass:** Door must be slightly open. Insert right column from the side. While holding column to the door swing door open and install (3) 10-24 x 3/8" Button Head Screws at the top, center and bottom of the door. Figure 4. Repeat step for other side. **Note: Use 1/8" Allen Wrench supplied with stove.**

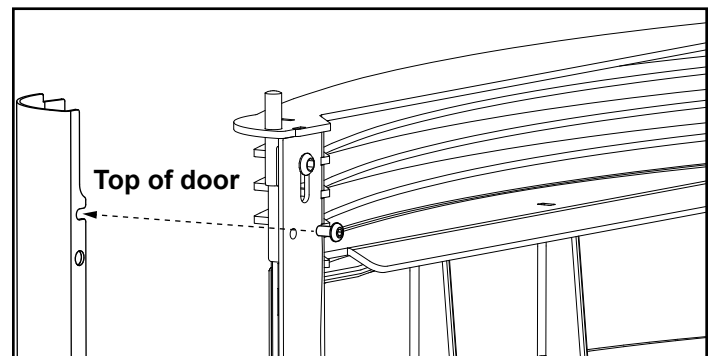

Figure 4



