

Owner's Manual

Operation & Care

INSTALLER: Leave this manual with party responsible for use and operation.

OWNER: Retain this manual for future reference.

Contact your dealer with questions regarding installation, operation or service.

NOTICE: DO NOT DISCARD THIS MANUAL

QUADRA-FIRE®

MT. VERNON E2 PELLET STOVE

Model(s):

MTV-E2-CSB MTV-E2-MBK
MTV-E2-PFT MTV-E2-PDB
MTV-E2-PBK MTV-E2-PMH



 Pellet Fuels Institute

Tested and Listed by  Portland Oregon USA
C US
 OMNI-Test Laboratories, Inc.
 061-S-83-2

WARNING



Please read this entire manual before use of this pellet fuel-burning room heater. Failure to follow these instructions could result in property damage, bodily injury, or death.

- Do not store or use gasoline or other flammable vapors and liquids in the vicinity of this or any other appliance.
- Do NOT burn garbage or flammable fluids such as gasoline, naphtha, or engine oil in room heater.
- Do not over fire - If heater or chimney connector glows, you are over firing. Over firing will void your warranty.
- Comply with all minimum clearances to combustibles as specified. Failure to comply may cause house fire.

WARNING



HOT SURFACES!
 Glass and other surfaces are hot during operation AND cool down.

Hot glass will cause burns.

- Do not touch glass until it is cooled
- NEVER allow children to touch glass
- Keep children away
- CAREFULLY SUPERVISE children in same room as fireplace.
- Alert children and adults to hazards of high temperatures
- **High temperatures may ignite clothing or other flammable materials.**
- Keep clothing, furniture, draperies and other flammable materials away.

CAUTION

Tested and approved for wood pellets and shelled corn only. Burning of any other type of fuel voids your warranty.

NOTE

A 2:1 mix of pellets to corn is approved, but may require the fire pot to be cleaned more frequently.

NOTE

To obtain a French translation of this manual, please contact your dealer or visit www.quadrafire.com
 Pour obtenir une traduction française de ce manuel, s'il vous plaît contacter votre revendeur ou visitez www.quadrafire.com

Installation and service of this appliance should be performed by qualified personnel. Hearth & Home Technologies recommends HHT Factory Trained or NFI certified professionals.

 **hearthED**
 FACTORY TRAINING
 Fuel Your Fire

 **NFI NATIONAL FIREPLACE INSTITUTE®**
 A CERTIFICATION AGENCY

CAUTION

Check building codes prior to installation.

- Installation MUST comply with local, regional, state and national codes and regulations.
- Consult local building, fire officials or authorities having jurisdiction about restrictions, installation inspection, and permits.



and Welcome to the Quadra-Fire Family!

NOTE: Clearances may only be reduced by means approved by the regulatory authority having jurisdiction

B. Sample of Serial Number / Safety Label

LOCATION: Back of Stove

Test Lab & Report No.

Model Name

Serial No.



CAUTION: HOT WHILE IN OPERATION DO NOT TOUCH, KEEP CHILDREN, CLOTHING AND FURNITURE AWAY. CONTACT MAY CAUSE SKIN BURNS. SEE NAMEPLATE AND INSTRUCTIONS.

ATTENTION: CHAUD LORS DE L'OPERATION. NE PAS TOUCHER. GARDEZ LES ENFANTS ET LES VÊTEMENTS LOIN DE L'ESPACÉ DÉSIGNÉ DE L'INSTALLATION. LE CONTACT PEUT CAUSER DES BRÛLURES À LA PEAU. VOIR L'ÉTIQUETTE ET LES INSTRUCTIONS.

Report:
061-S-83-2

QUADRA-FIRE

Mt Vernon E2 Pellet Stove

SERIAL NO. / NUMÉRO DU

007058

Listed Solid Fuel Room Heater/Pellet Type. Also suitable for Mobile Home Installation. This appliance has been tested and listed for use in Manufactured Homes in accordance with CAR 814-23-9000 through 814-23-909.

Appareil de chauffage de combustible solide type de bouillettes. Accepté dans l'installation dans les maisons mobiles. Cet appareil a été testé et enregistré pour l'usage dans les Maisons Mobiles en accord avec CAR 814-23-9000 jusqu'à 814-23-909.

PREVENT HOUSE FIRES / PRÉVENTION DES FEUX DE MAISON
Install and use only in accordance with manufacturer's installation and operating instructions. Contact local building or fire officials about restrictions and inspection in your area.

WARNING - FOR MOBILE HOMES: Do not install appliance in a sleeping room. An outside combustion air inlet must be provided. The structural integrity of the mobile home floor, ceiling and walls must be maintained. Refer to manufacturer's instructions and local codes for precautions required for passing chimney through a combustible wall or ceiling. Inspect and clean vent system frequently in accordance with manufacturer's instructions. **DO NOT CONNECT THIS UNIT TO A CHIMNEY SERVING ANOTHER APPLIANCE.** Use a 3" or 4" diameter type "L" or "PL" venting system.

Installez et utilisez en accord avec les instructions d'installation et d'utilisation du fabricant. Contactez le bureau de la construction ou les services incendie pour des restrictions et des inspections d'installation dans votre zone. Ne pas installer l'appareil dans une chambre à coucher.

AVIS - Pour Les Maisons Mobiles: Ne pas installer dans une chambre à coucher. Un tuyau extérieur de combustion d'air doit être installé et maintenu. La structure intégrale du mobile home doit être maintenue. Consultez les instructions du fabricant et les codes locaux pour les précautions requises pour passer une cheminée à travers une paroi ou un plafond combustibles. **N'ENRANGENEZ PAS LA CHEMINÉE À TRAVERS UN AUTRE APPAREIL.** Utilisez système de ventilation "L" ou "PL" diamètre 76mm.

Conforms to ASTM Std E1509-12, Certified to UL C 9827-00, Room Heating Pellet Burning type. (UM) 84-HUD FOR USE ONLY WITH PELLETTIZED WOOD FUEL. Do not use any other type of fuel.

Conforme à la norme ASTM E1509-12 Std C 9827-00, la norme ULC S627-00, Room Heating Pellet Burning type. (UM) 84-HUD POUR USAGE AVEC LES BOULETTES DE BOIS PELLETTISÉES. NE PAS UTILISER D'AUTRE TYPE DE COMBUSTIBLE.

Input Rating: 55,000 Btu/hr; Electrical Rating: 115 VAC, 60 Hz, Start 2.9 Amps, Run 2.45 Amps. Route power cord away from unit. Do not route cord under or in front of appliance. Do not obstruct the space beneath the heater.

DANGER: Risk of electrical shock. Disconnect power supply before servicing. Replace glass only with 5mm ceramic. To start, turn dial control to desired setting, set thermostat above room temperature, the stove will light automatically, shutdown, turn dial control to OFF or set thermostat below room temperature. Further instruction refer to owner's manual. Keep viewing doors tightly closed during operation. Keep viewing and ash removal doors tightly closed during operation.

DANGER: Il y a un risque de décharge électrique. Déconnectez le fil électrique de la prise de contact avant de faire le service. Remplacez la vitre seulement avec une vitre en céramique de 5mm disponible chez votre fournisseur. Pour commencer, tournez la molette de réglage à la température désirée et réglez le thermostat au-dessus de la température ambiante, le poêle s'allumera automatiquement. Pour éteindre, tournez la molette de réglage sur OFF ou réglez le thermostat dessous de la température ambiante. Pour des instructions supplémentaires, référez vous au manuel du propriétaire. Gardez la porte d'ouverture et la porte des cendres fermées hermétiquement durant l'opération.

MINIMUM CLEARANCES TO COMBUSTIBLE MATERIALS / ESPACES LIBRES MINIMUM DES MATÉRIAUX

A	Back Wall / Mur Arrière	2 in (51 mm)
B	Side Wall / Mur De Côté	6 in (152 mm)
C	"L" or "PL" Pipe to Back Wall / "L" ou "PL" Un Tuyau Mur Arrière	1 in (25 mm)
D	Side Wall / Mur De Côté	2 in (51 mm)

FLOOR PROTECTION / PROTECTION DU SOL

Floor protector must be non-combustible material, extending beneath heater and to the front/sides/rear as indicated. Measure front distance (I) from the surface of the glass door.

*Non-combustible floor protection must extend 2 inches (51mm) beneath the flue pipe when installed with horizontal venting or under the Top Vent Adapter with vertical installation. RECOMMENDED IN USA; REQUIRED IN CANADA.

*Un protecteur incombustible de plancher doit s'étendre 2 inches (51mm) sous le conduit de cheminée pour une installation de ventilation horizontale ou sous un adaptateur de ventilation de dessus pour une installation verticale. RECOMMANDÉ AUX ÉTATS-UNIS; NECESSAIRE AU CANADA.

Owners Manual



Manufactured by/Fabrique par

HEARTH-HOME
1445 North Highway, Coville, WA 98114
www.quadrafire.com

U.S. ENVIRONMENTAL PROTECTION AGENCY
Certified to comply with 2015 particulate emission standards at 0.5 g/hr EPA Methods 28 and 50. Not approved for sale after May 15, 2020.

Install Manual



DO NOT REMOVE THIS LABEL / NE PAS ENLEVER L'ÉTIQUETTE

2015	2016	2017	JAN	FEB	MAR	APR	MAY	JUN	JUL	AUG	SEP	OCT	NOV	DEC
<input type="checkbox"/>	<input type="checkbox"/>	<input type="checkbox"/>	<input type="checkbox"/>	<input type="checkbox"/>	<input type="checkbox"/>	<input type="checkbox"/>	<input type="checkbox"/>	<input type="checkbox"/>	<input type="checkbox"/>	<input type="checkbox"/>	<input type="checkbox"/>	<input type="checkbox"/>	<input type="checkbox"/>	<input type="checkbox"/>

Made in U.S.A. of US and imported parts.
Fabriqué aux États-Unis-d'Amérique par des pièces d'origine américaine et pièces importées.





Safety Alert Key:

- **DANGER!** Indicates a hazardous situation which, if not avoided will result in death or serious injury.
- **WARNING!** Indicates a hazardous situation which, if not avoided could result in death or serious injury.
- **CAUTION!** Indicates a hazardous situation which, if not avoided, could result in minor or moderate injury.
- **NOTICE:** Indicates practices which may cause damage to the appliance or to property.

TABLE OF CONTENTS

<p>A. Sample of Serial Number / Safety Label2 B. Warranty Policy4 C. Quick Start Guide.....7</p> <p>1 Listing and Code Approvals8</p> <p>A. Appliance Certification.....8 B. BTU & Efficiency Specifications8 C. Glass Specifications.....8 D. Electrical Rating8 E. Mobile Home Approved.....8</p> <p>2 Operating Instructions9</p> <p>A. Fire Safety.....9 B. Non-Combustible Materials.....9 C. Combustible Materials9 D. Fuel Material and Fuel Storage.....9 E. Before Your First Fire.....10 F. Filling the Hopper.....10 G. User Dial Control10 H. Normal Startup Sequence.....10 I. Fire pot Purge10 J. Shutdown.....10 K. Fire Characteristics11 L. Your Pellet Appliance’s General Operating Parts11 M. LED Color Coding Chart and Explanation12 N. Restarting the Appliance13 O. Clear Space13 P. Trim Adjustment13 Q. Programming Thermostat14 R. Frequently Asked Questions15</p>	<p>3 Maintenance and Service16</p> <p>A. Proper Shutdown Procedure.....16 B. Quick Reference Maintenance Chart.....16 C. General Maintenance and Cleaning17 D. Soot or Creosote Fire Awareness20 E. High Ash Fuel Content Maintenance.....21 F. Baffle Removal21 G. Glass Replacement21 H. Convection Blower Replacement22 I. Combustion/Exhaust Blower Replacement23</p> <p>4 Troubleshooting Guide.....24</p> <p>5 Reference Materials28</p> <p>A. Component Functions28 B. Service and Maintenance.....29 C. Exploded Drawings.....30 D. Parts List.....31</p>
--	---

C. Warranty Policy

**Hearth & Home Technologies
LIMITED LIFETIME WARRANTY**

Hearth & Home Technologies, on behalf of its hearth brands (“HHT”), extends the following warranty for HHT gas, wood, pellet and electric hearth appliances that are purchased from an HHT authorized dealer.

WARRANTY COVERAGE:

HHT warrants to the original owner of the HHT appliance at the site of installation, and to any transferee taking ownership of the appliance at the site of installation within two years following the date of original purchase, that the HHT appliance will be free from defects in materials and workmanship at the time of manufacture. After installation, if covered components manufactured by HHT are found to be defective in materials or workmanship during the applicable warranty period, HHT will, at its option, repair or replace the covered components. HHT, at its own discretion, may fully discharge all of its obligations under such warranties by replacing the product itself or refunding the verified purchase price of the product itself. The maximum amount recoverable under this warranty is limited to the purchase price of the product. This warranty is subject to conditions, exclusions and limitations as described below.

WARRANTY PERIOD:

Warranty coverage for consumers begins at the date of installation. In the case of new home construction, warranty coverage begins on the date of first occupancy of the dwelling or six months after the sale of the product by an independent, authorized HHT dealer/distributor, whichever occurs earlier. However, the warranty shall commence no later than 24 months following the date of product shipment from HHT, regardless of the installation or occupancy date. The warranty period for parts and labor for covered components is produced in the following table.

The term “Limited Lifetime” in the table below is defined as: 20 years from the beginning date of warranty coverage for gas appliances, and 10 years from the beginning date of warranty coverage for wood and pellet appliances. These time periods reflect the minimum expected useful lives of the designated components under normal operating conditions.

Warranty Period		HHT Manufactured Appliances and Venting						Components Covered
Parts	Labor	Gas (Indoor)	Gas/Wood (Outdoor Protected) *	Pellet	Wood	Electric	Venting	
1 Year		X	X	X	X	X	X	All parts and material except as covered by Conditions, Exclusions, and Limitations listed
2 Years				X	X			Igniters, auger motors, electronic components, and glass
		X		X	X			Factory-installed blowers
					X			Molded refractory panels
		X						Ignition Modules
3 Years				X				Firepots, burn pots, mechanical feeders/auger assemblies
5 Years	1 Year	X						Vent Free burners, Vent Free ceramic fiber logs, Aluminized Burners
				X	X			Castings and Baffles
6 Years	3 Years				X			Catalyst - limitations listed
7 Years	3 Years			X	X			Manifold tubes, HHT chimney and termination
10 Years	1 Year	X						Burners, logs and refractory
Limited Lifetime	3 Years	X		X	X			Firebox and heat exchanger, Grate and Stainless Steel Burners, FlexBurn® System (engine, inner cover, access cover, and fire back)
90 Days		X	X	X	X	X	X	All replacement parts beyond warranty period

WARRANTY CONDITIONS:

- This warranty only covers HHT appliances that are purchased through an HHT authorized dealer or distributor. A list of HHT authorized dealers is available on the HHT branded websites.
- This warranty is only valid while the HHT appliance remains at the site of original installation.
- This warranty is only valid in the country in which the HHT authorized dealer or distributor that sold the appliance resides.
- Contact your installing dealer for warranty service. If the installing dealer or distributor is unable to provide necessary parts, contact the nearest HHT authorized dealer or supplier. Additional service fees may apply if you are seeking warranty service from a dealer other than the dealer from whom you originally purchased the product.
- Check with your dealer in advance for any costs to you when arranging a warranty call. Travel and shipping charges for parts are not covered by this warranty.
- Limited Catalyst Warranty
 - For wood burning products containing a catalyst, the catalyst will be warranted for a six-year period as follows: if the original catalyst or a replacement catalyst proves defective or ceases to maintain 70% of its particulate emission reduction activity (as measured by an approved testing procedure) within 36 months from the purchase date, the catalyst will be replaced for free.
 - From 37 to 72 months a pro-rated credit will be allowed against a replacement catalyst and labor credit necessary to install the replacement catalyst. The proration rate is as follows:

Amount of Time Since Purchase	Credit Towards Replacement Cost
0 – 36 Months	100%
37 – 48 Months	30%
49 – 60 Months	20%
61 – 72 Months	10%

- Any replacement catalyst will be warranted under the terms of the catalyst warranty for the remaining term of the original warranty. The purchaser must provide the name, address, and telephone number of the location where the product is installed, proof of original purchase date, date of failure, and any relevant information regarding the failure of the catalyst.

WARRANTY EXCLUSIONS:

This warranty does not cover the following:

- Changes in surface finishes as a result of normal use. As a heating appliance, some changes in color of interior and exterior surface finishes may occur. This is not a flaw and is not covered under warranty.
- Damage to printed, plated, or enameled surfaces caused by fingerprints, accidents, misuse, scratches, melted items, or other external sources and residues left on the plated surfaces from the use of abrasive cleaners or polishes.
- Repair or replacement of parts that are subject to normal wear and tear during the warranty period are not covered. These parts include: paint, wood and pellet gaskets, firebricks, grates, flame guides, batteries and the discoloration of glass.
- Minor expansion, contraction, or movement of certain parts causing noise. These conditions are normal and complaints related to this noise are not covered by this warranty.

Damages resulting from: (1) failure to install, operate, or maintain the appliance in accordance with the installation instructions, operating instructions, and listing agent identification label furnished with the appliance; (2) failure to install the appliance in accordance with local building codes; (3) shipping or improper handling; (4) improper operation, abuse, misuse, continued operation with damaged, corroded or failed components, accident, or improperly/incorrectly performed repairs (5) environmental conditions, inadequate ventilation, negative pressure, or drafting caused by tightly sealed constructions, insufficient make-up air supply, or handling devices such as exhaust fans or forced air furnaces or other such causes; (6) use of fuels other than those specified in the operation instructions; (7) installation or use of components not supplied with the appliance or any other components not expressly authorized and approved by HHT; (8) modification of the appliance not expressly authorized and approved by HHT in writing; and/or (9) interruptions or fluctuations of electrical power supply to the appliance.

- Non-HHT venting components, hearth connections or other accessories used in conjunction with the appliance. Any part of a pre-existing fireplace system in which an insert or a decorative gas appliance is installed.
- HHT's obligation under this warranty does not extend to the appliance's capability to heat the desired space. Information is provided to assist the consumer and the dealer in selecting the proper appliance for the application. Consideration must be given to the appliance location and configuration, environmental conditions, insulation and air tightness of the structure.

This warranty is void if:

- The appliance has been over-fired, operated in atmospheres contaminated by chlorine, fluorine, or other damaging chemicals. Over-firing can be identified by, but not limited to, warped plates or tubes, deformation/warping of interior cast iron structure or components, rust colored cast iron, bubbling, cracking and discoloration of steel or enamel finishes.
- The appliance is subjected to prolonged periods of dampness or condensation.
- There is any damage to the appliance or other components due to water or weather damage which is the result of, but not limited to, improper chimney or venting installation.

LIMITATIONS OF LIABILITY:

- The owner's exclusive remedy and HHT's sole obligation under this warranty, under any other warranty, express or implied, or in contract, tort or otherwise, shall be limited to replacement, repair, or refund, as specified above. In no event will HHT be liable for any incidental or consequential damages caused by defects in the appliance. Some states do not allow exclusions or limitation of incidental or consequential damages, so these limitations may not apply to you. This warranty gives you specific rights; you may also have other rights, which vary from state to state.

EXCEPT TO THE EXTENT PROVIDED BY LAW, HHT MAKES NO EXPRESS WARRANTIES OTHER THAN THE WARRANTY SPECIFIED HEREIN. THE DURATION OF ANY IMPLIED WARRANTY IS LIMITED TO DURATION OF THE EXPRESSED WARRANTY SPECIFIED ABOVE.

D. Quick Start Guide

QUICK START GUIDE

Before you plug in this appliance, follow these instructions

Set Up

1. Empty Fire box
2. Add pellets and close lid
3. Turn DIAL to OFF
4. Plug in the appliance
 - Exhaust blower will run for about 45 Seconds (**wait for it to stop before priming**)
 - Green light will start flashing
5. Ensure thermostat is connected properly per included instructions.

Prime

1. After the exhaust blower has stopped; quickly turn the dial from OFF to HI two times



- The LIGHT will turn solid green and pellets will feed. Wait for 2 minutes
- If the LIGHT did not turn solid green:
 - Turn dial back to OFF
 - Unplug appliance, plug it back in and repeat

Priming is only needed for first fire or starting fire on empty hopper.

Note: The prime function is only required during initial set up of the unit, or after the unit has alarmed out due to an empty hopper. Priming while under normal operating conditions will cause the fire pot to overfill.

Run

1. Press up arrow on thermostat to desired temperature.

*appliance will not turn on unless target temperature is minimum of one degree above room temperature.



2. Choose Setting: LO – HI*
Green LIGHT will begin flashing and stove will start

It may take as long as 10 minutes to achieve a fire in the fire pot. Turning the knob or thermostat to off during this time will interrupt the startup process.

*For first fire, HHT recommends running on HI for first 30 minutes

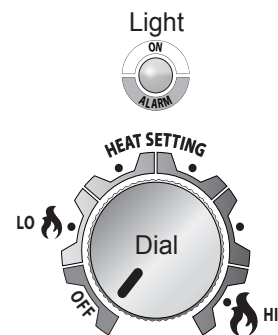

QUADRA-FIRE



Control Panel

1 Listing and Code Approvals

A. Appliance Certification

Model	Mt. Vernon Pellet Stove E2
Laboratory	OMNI Test Laboratories, Inc.
Report No.	061-S-83-2
Type	Solid Fuel Room Heater, Pellet and Shelled Corn Fuel Burning Type
Standard	ASTM E1509-12, ULC S627-00 and (UM) 84-HUD, Mobile Home Approved.
FCC	Complies with Part 15 of FCC Rules. Operation is subject to the following two conditions: (1) this device may not cause harmful interference, and (2) this device must accept any interference received, including interference that may cause undesired operation.

NOTICE: This installation must conform with local codes. In the absence of local codes you must comply with the **ASTM E1059-12, ULC S627-00, (UM) 84-HUD and ULC/ORD-C-1482.**

The Quadra-Fire Mt. Vernon E2 Pellet Heater meets the U.S. Environmental Protection Agency’s emission limits for pellet heaters sold after May 15, 2015.

This pellet heater needs periodic inspection and repair for proper operation. It is against federal regulations to operate this pellet heater in a manner inconsistent with operating instructions in this manual.

B. BTU & Efficiency Specifications

EPA Certification #:	984-15
EPA Certified Emissions:	0.5 grams per hour
*LHV Tested Efficiency:	81.6 %
**HHV Tested Efficiency:	75.5 %
***EPA BTU Output:	13,900 to 42,200 / hr.
****BTU Input:	18,100 to 55,000 / hr.
Vent Size:	3 or 4 inches, “L” or “PL”
Hopper Capacity:	80 lbs.
Fuel	Wood Pellets
* Weighted average LHV efficiency using data collected during EPA emissions test.	
**Weighted average HHV efficiency using data collected during EPA emissions test.	
***A range of BTU outputs based on EPA Default Efficiency and the burn rates from the low and high EPA tests.	
****Based on the maximum feed rate per hour multiplied by approximately 8600 BTU’s which is the average BTU’s from a pound of pellets.	

C. Glass Specifications

This stove is equipped with 5mm ceramic glass. Replace glass only with 5mm ceramic glass. Please contact your dealer for replacement glass.

D. Electrical Rating

115 VAC, 60 Hz, Start 2.9 Amps, Run 2.45 Amps

E. Mobile Home Approved

- This appliance is approved for mobile home installations when not installed in a sleeping room and when an outside combustion air inlet is provided.
- The structural integrity of the mobile home floor, ceiling, and walls must be maintained.
- The appliance must be properly grounded to the frame of the mobile home and use only Listed pellet vent Class “L” or “PL” connector pipe.
- Outside Air Kit (OAK-3) must be installed in a mobile home installation.

WARNING



Fire Risk.

Hearth & Home Technologies disclaims any responsibility for, and the warranty will be voided by, the following actions:

- Installation and use of any damaged appliance.
 - Modification of the appliance.
 - Installation other than as instructed by Hearth & Home Technologies.
 - Installation and/or use of any component part not approved by Hearth & Home Technologies.
 - Operating appliance without fully assembling all components.
 - Operating appliance without legs attached (if supplied with unit).
 - Do NOT Over fire - If appliance or chimney connector glows, you are over firing.
- Any such action that may cause a fire hazard.



Improper installation, adjustment, alteration, service or maintenance can cause injury or property damage. For assistance or additional information, consult a qualified installer, service agency or your dealer.

NOTE: Hearth & Home Technologies, manufacturer of this appliance, reserves the right to alter its products, their specifications and/or price without notice.

Quadra-Fire is a registered trademark of Hearth & Home Technologies.

User Guide

2 Operating Instructions

	WARNING
	<p>Fire Risk.</p> <ul style="list-style-type: none"> Do not operate appliance before reading and understanding operating instructions.
	<ul style="list-style-type: none"> Failure to operate appliance properly may cause a house fire.

A. Fire Safety

To provide reasonable fire safety, the following should be given serious consideration:

- Install at least one smoke detector on each floor of your home.
- Install at least one carbon monoxide detector on each floor of your home.
- Locate smoke detector away from the heating appliance and close to the sleeping areas.
- Follow the smoke detector manufacturer's placement and installation instructions and maintain regularly.
- Follow the carbon monoxide manufacturer's placement and installation instructions and maintain regularly.
- Conveniently locate a Class A fire extinguisher to contend with small fires.
- In the event of a hopper fire:
 - Evacuate the house immediately.
 - Notify fire department.

B. Non-Combustible Materials

Material which will not ignite and burn, composed of any combination of the following:

- | | | | |
|---------|-----------|---------|------------|
| - Steel | - Plaster | - Glass | - Tile |
| - Brick | - Iron | - Slate | - Concrete |

Materials reported as passing **ASTM E 136, Standard Test Method for Behavior of Metals, in a Vertical Tube Furnace of 750° C.**

C. Combustible Materials

Material made of/or surfaced with any of the following materials:

- | | | |
|------------------------|-----------|----------------|
| - Compressed Paper | - Wood | - Plywood/OSB |
| - Sheet Rock (drywall) | - Plastic | - Plant Fibers |

Any material that can ignite and burn: flame proofed or not, plastered or non-plastered.

D. Fuel Material and Fuel Storage

Pellet fuel quality can greatly fluctuate. We recommend that you buy fuel in multi-ton lots whenever possible. However, we do recommend trying various brands before purchasing multi-ton lots to ensure your satisfaction.

Fuel Material

- Made from sawdust or wood by-products
- Depending on the source material it may have a high or low ash content.

Higher Ash Content Material

- Hardwoods with a high mineral content
- Fuel that contains bark
- Standard grade pellets or high ash pellets

Lower Ash Content Material

- Most softwoods
- Fuels with low mineral content
- Most premium grade pellets

Corn

- A 2:1 mix of pellets to corn is approved, but may require the fire pot to be cleaned more frequently.
- When using a pellet/corn fuel mixture, it is recommended that the trim adjustment is set to -4 (see pg. 12).
- Corn must be free of debris. Never burn corn straight from the field. It will clog the auger mechanism.
- Corn with excessive grain dust must be screened by sifting with 3/16 (4.76mm) inch mesh screening
- Do not use corn that contains additives such as oils or means or has been chemically treated with pesticides. It will void your warranty and destroy the exhaust system.

Clinkers

Minerals and other non-combustible materials such as sand will turn into a hard, glass-like substance called a clinker when heated in the fire pot.

Trees from different areas will vary in mineral content. That is why some fuels produce more clinkers than others.

Moisture

Always burn dry fuel. Burning fuel with high moisture content takes heat from the fuel and tends to cool the appliance, robbing heat from your home. Damp pellet fuel can clog the feed system.

Size

- Pellets are either 1/4 inch or 5/16 inch (6-8mm) in diameter
- Length should be no more than 1-1/2 inches (38mm)
- Pellet lengths can vary from lot to lot from the same manufacturer
- Due to length variations, the feed rate may need adjusting occasionally

Performance

- Higher ash content requires the fire pot and the ash drawer to be emptied more frequently
- Hardwoods require more air to burn properly
- Premium wood pellets produce the highest heat output

MT. VERNON E2

- Burning pellets longer than 1-1/2 inches (38mm) can cause an inconsistent fuel feed rate and/or missed ignitions or feed jams.

Storage

- Wood pellets should be left in their original sealed bag until using to prevent moisture absorption
- Do not store any pellet fuel within the clearance requirements or in an area that would hinder routine cleaning and maintenance

E. Before Your First Fire

1. First, make sure your appliance has been properly installed and that all safety requirements have been met. Pay particular attention to the fire protection and venting.
2. Double check that the firebox is empty and the fire pot floor is fully closed.
3. Close and latch the door.

F. Filling the Hopper

Open the hopper lid by lifting the handle. Fill the hopper with fuel. Close the hopper lid. The unit will not feed with the hopper lid open and the fire will go out.

NOTE: UNIT CAN USE 2:1 PELLET/CORN MIXTURE.
We recommend the use of a 2:1 pellet/corn mixture. The only change in operation is that the feed rate may require a slight adjustment.

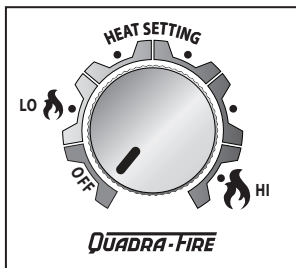

Figure 10.1

G. User Dial Control

The appliance has one dial control located on the side of the unit (behind a drop door) used for changing the heat setting and restarting the appliance. There are five heat settings on this dial ranging to include: LOW, MED-LOW, MED, MED-HIGH, and HIGH. **Figure 10.1**

Turn the dial control to the desired heat setting and turn the appliance ON and OFF using the thermostat.

H. Normal Startup Sequence

The unit will go into the ignition sequence followed by a start up sequence (the green LED will flash rapidly).

The ignition sequence involves the exhaust blower and igniter turning on, and the feed motor running in two stages. The first stage involves the feed motor running continuously

for about a minute to start loading pellets into the fire pot. In the second stage, the feed motor will begin cycling on and off.

When the pellets are warming - on the verge of igniting - it is not uncommon for the firebox to fill with smoke.

Once ignition happens, the smoke should quickly disappear. During this stage, as well as any part during the burn process, the front door should not be opened.

This startup cycle continues until the unit senses ignition by a rise in the exhaust temperature or the unit times out. Following the ignition cycle the unit continues to feed pellets to build up the fire.

After warming up, the convection blower will begin to blow warm air into the room. As the appliance increases heat the blower will increase its output.

I. Fire pot Purge

Purpose: To help remove debris from the fire pot and help the unit burn as efficient as possible.

The frequency of the purge cycle is once every 30 minutes while the unit is burning. During the fire pot purge, the feed is reduced to the lowest setting and the exhaust blower ramps up to a very high setting. The purge cycle lasts 99 seconds.

The purge cycle does not replace daily cleaning.

J. Shutdown

To shut the appliance down, turn the dial control to OFF or turn the thermostat to OFF. During the shutdown process, the light will flash amber or green rapidly.

Unlike the fire pot purge, during shutdown existing fuel in the fire pot will continue to burn without the feed motor running; but, the exhaust and convection blowers will remain on until the exhaust has cooled.

NOTE: If maintenance or daily cleaning is going to be conducted immediately following a shutdown, please use caution as components especially those inside the firebox may still be hot.

Due to safety precautions:

- If the dial control is turned to OFF and back on (even if by mistake) the unit will go through the shutdown sequence before restarting.
- Additionally, if the thermostat is turned to "OFF" during operation the appliance will go through a shutdown sequence before restarting.

CAUTION

HOT WHILE IN OPERATION. KEEP CHILDREN, CLOTHING AND FURNITURE AWAY. CONTACT MAY CAUSE SKIN BURNS.

K. Fire Characteristics

The overall height of the flame will vary throughout the burn for a couple of reasons:

- 1) The flame will vary based on type of fuel or batch of fuel.
- 2) The unit adjusts the burn rate according to the dial setting – the further the dial is rotated clockwise the higher the flame and consequently, heat output.
- 3) General maintenance and cleaning. Infrequent or poor general maintenance will result in poorer performance. Indicators for additional maintenance activities include:
 - lazy flame
 - black-sooted glass
 - pellets not igniting
 - excess pellets falling to the side of the fire pot.
- 4) See trim adjustment section for additional information.

WARNING

HOT SURFACES!



Glass and other surfaces are hot during operation AND cool down.

Hot glass will cause burns.

• **DO NOT** touch glass until it is cooled.

- NEVER allow children to touch glass.
- Keep children away.
- CAREFULLY SUPERVISE children in same room as appliance.
- Alert children and adults to hazards of high temperatures.

High temperatures may ignite clothing or other flammable materials.

- Keep clothing, furniture, draperies and other flammable materials away.

CAUTION

Odors and vapors released during initial operation.

- Curing of high temperature paint.
- Open windows for air circulation.

Odors may be irritating to sensitive individuals.

NOTICE: If you expect children to come into contact with this appliance, we recommend a barrier such as a decorative screen. See your retailer for suggestions.

L. Your Pellet Appliance's General Operating Parts

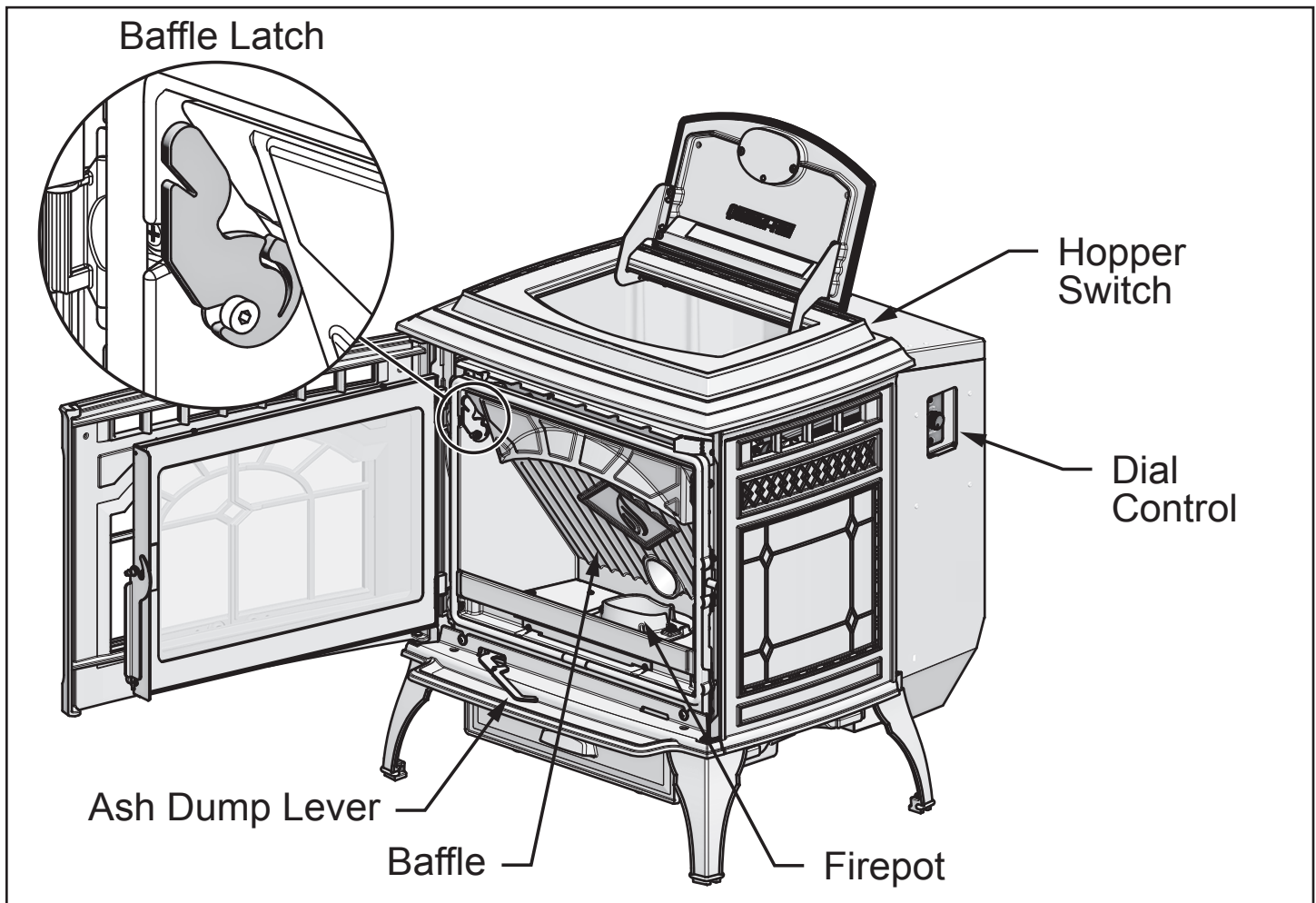

M. LED Color Coding Chart and Explanation

The number of flashes between pauses is per one second unless otherwise indicated.

LED Color	No. of Flashes between pauses	Description	Notes
Green	Steady ON while priming feed tube (max time 2 minutes)	Feed Motor is running continuously. (priming the feed tube)	When priming the feed system and filling the fire pot, DO NOT OVERFILL Fire pot FOR IGNITION. The unit will automatically go into start up following the prime function.
Green	1x every 2 seconds	Unit is on standby	To start appliance, follow start up sequence.
Green	Blinks Continuously	Appliance is in the start up/ignition sequence or in shutdown.	During shut down, the blowers will shut off when the exhaust temperature has cooled.
Green	1X	Stage 1: Low heat	BTU Range: 14,620 - 19,694 Average: 19,054
Green	2X	Stage 2: Med-Low heat	BTU Range: 22,102 - 23,506 Average: 22,735
Green	3X	Stage 3: Med heat	BTU Range: 30,778 - 32,680 Average: 31,603
Green	4X	Stage 4: Med-Hi heat	BTU Range: 38,576 - 42,914 Average: 40,665
Green	5X	Stage 5: Hi heat	BTU Range: 49,830 - 52,460 Average: 51,528
Amber	Blinks Continuously	Appliance is in the shut-down sequence.	During shut down, the blowers will shut off when the exhaust temperature has cooled.
Red	1X	Empty Hopper Alarm	This alarm is caused by the fire going out from lack of fuel. Reset by turning to "OFF" then turn dial to desired setting.
Red	2X	Exhaust Probe Alarm	Failed component error. See troubleshooting section for more information.
Red	4X	Missed Ignition	There are a total of 2 tries per ignition sequence. If after 2 tries there is no rise in exhaust temperature this error will occur. See the troubleshooting section for additional information.
Red	6X	Encoder Alarm	Failed Component Error: Exhaust Speed Sensor. See troubleshooting guide for more information
Red	8X	Exhaust Over Temperature Alarm	See troubleshooting guide for more information.

 **WARNING**



Fire Risk
Do NOT operate appliance:

- With appliance door open.
- Fire pot floor open.

Do NOT store fuel:

- Closer than required clearances to combustibles to appliance
- Within space required for loading or ash removal.

N. Restarting the Appliance

Restart Process

1. When the unit has run out of fuel and the “empty hopper” error code illuminates, add pellet fuel to the hopper.
2. Dump the ashes and clinkers built up in the fire pot by pulling the ash dump removal handle out several times. Make sure clinkers have dropped into the ash pan then return the handle to fully closed position.
3. Turn the dial control to OFF and then up to high 2X to prime.
4. After seeing pellets drop then turn to desired setting to reset the appliance control system. The appliance will then begin its startup sequence.

Restarting After a Power Failure

1. For an electrical disruption the appliance will start on its own without need for priming - providing the control system is asking for heat.
2. The appliance will always go through a normal shut-down sequence before restarting.

O. Clear Space

NOTICE: Clearances may only be reduced by means approved by the regulatory authority having jurisdiction.

Mantel: Avoid placing candles and other heat-sensitive objects on mantel or hearth. Heat may damage these objects.

P. Trim Adjustment (Factory default setting is -2)

The small dial located below the main dial control is used to adjust the amount of fuel and combustion air used for efficient clean burning. Adjusting the trim along with proper cleaning of the fire pot and heat exchanger will help achieve maximum performance of your Mt Vernon E2 Appliance.

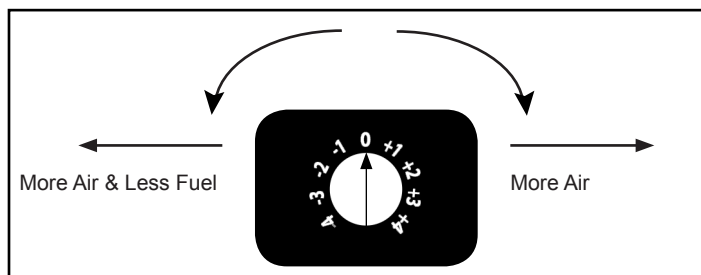

Figure 13.1

ance.

Your appliance may need to be adjusted based on any or all of the following:

- Elevation (3000 feet above Sea Level or Higher)
- Venting/Installation Configurations (installations with greater than 4' horizontal or more than two 90 degree elbows)
- Fuel Quality (lower BTU fuels or fuels with high ash content)
- Fuel Type (hardwood, softwood, lower BTU fuels)
- Appliances not properly adjusted will:
- Require more frequent cleanings
- Result in nuisance shut downs and/or missed ignitions

- Waste fuel

Consult your QuadraFire Dealer with specific questions regarding proper adjustments for maximum performance.

Where to Start:

If Burning Hardwood Pellet Fuel

QuadraFire recommends setting the appliance at a -4 trim setting as a start. From our testing, hardwood fuels burn well between -4 and -2 settings.

If Burning Lower BTU Pellet Fuel, Utility Pellet Fuel, or High Ash Pellet Fuel

QuadraFire recommends setting the appliance and leaving at a -4 trim setting. From our testing, lower BTU fuels result in large clinkers in the bottom of the fire pot during normal operation. Using this type of fuel will increase the recommended fire pot cleaning interval.

If Burning Softwood Pellet Fuel

QuadraFire recommends starting at a -2 trim setting and adjusting based on installation configurations. From our testing, softwood fuels burn well at a variety of settings.

If Elevation is 3000 feet above Sea Level or Higher

When burning at higher elevations you will need more air for the fire to burn properly. QuadraFire recommends starting with a Trim Setting of -3. From our testing, appliances at higher elevations burn best at settings -4, -3, +3, and +4. Review fuel types and installation configurations for choosing the right setting.

If appliance has long horizontal venting sections or more than two 90 degree Elbows

QuadraFire recommends starting at a -4 trim setting and making adjustments based on fuel type and elevation. From our testing, we have found that -4, -3, +3, or +4 have worked well depending on fuels.

Indicators that Trim Adjustment is needed:

1. The flame appears lazy
2. Smoke can be seen in the firebox after start up during normal burn
3. Excessive build up of clinkers taller than a 1/2" in the bottom of the fire pot

The fire goes out when in normal operating mode

Q. Programming Thermostat

The thermostat maintains a desired room temperature. The 5-2 day programmable function allows one program for week days and a separate program for Saturday/Sunday. (Up to 4 periods per day).

Thermostat Controls

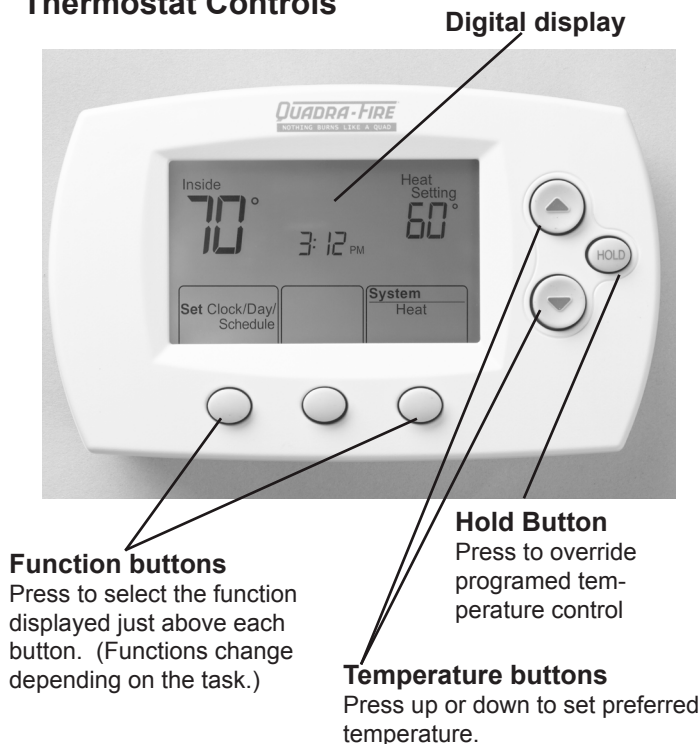

Function buttons
Press to select the function displayed just above each button. (Functions change depending on the task.)

Temperature buttons
Press up or down to set preferred temperature.

Hold Button
Press to override programmed temperature control

Program Schedule

Pre-set settings are shown below.

You can program 4 time periods each day, with different settings for weekdays and weekends.

Wake- Set to time and temperature you want in the morning until you leave for the day.

Leave- Set the time and temperature you want the heat output reduced to during the day.

Return- Set the time and temperature to what you want the heat output increased to in the evening.

Sleep – Set the time and temperature to what you want for overnight.

	Heat
Wake (6:00 am)	70° F
Leave (8:00 am)	62° F
Return (6:00 pm)	70° F
Sleep (10:00 pm)	62° F

To Adjust Program Schedules

1. Press **SET CLOCK/DAY/SCHEDULE**, then **SET SCHEDULE**.
2. Press **▲ / ▼** to set your weekday wake time (Mon-Fri), then press **NEXT**.
3. Press **▲ / ▼** to set the temperature for this time period, then press **NEXT**.
4. Set time and temperature for the next time period (Leave). Repeat steps 2 and 3 for each weekday time period.
5. Press **NEXT** to set weekend time periods (Sat-Sun), then press **DONE** to save & exit.

NOTE: You can press **CANCEL PERIOD** to eliminate unwanted time periods (except Wake).

Program Schedule Override (temporary)

Press **▲** or **▼** to immediately adjust the temperature. This will temporarily override the temperature setting for the current time period.

The new temperature will be maintained only until the next programmed time period begins. For example, if you want to turn up the heat early in the morning, it will automatically be lowered later, when you leave for the day.

To cancel the temporary setting at any time, press **RUN SCHEDULE**.

Program Schedule Override (permanent)

Press **HOLD** to permanently adjust the temperature. This will override the temperature settings for all time periods.

The "Hold" feature turns off the program schedule and allows you to adjust the thermostat manually, as needed.

Whatever temperature you set will be maintained 24 hours a day, until you manually change it, or press **RUN SCHEDULE** to cancel "Hold" and resume the programmed schedule.

Saturday and Sunday can be programmed individually by changing the format from 5-2 to 5-1-1. To change the format :

1. Press and hold the up button and the center button until the display changes.
2. Press up or down to change system function number to 16.
3. Press **NEXT** to advance to next function.
4. Press up or down to change status number to 1.
5. Press **DONE** to exit and save settings.

R. Frequently Asked Questions

What causes my glass to become dirty?

If the glass has white ash build up it is normal and the glass should be cleaned. If it is a black soot build up airflow through the unit may be restricted. The most often cause is overdue maintenance and cleaning. See “Maintaining and Servicing Appliance” and/or make adjustments to the trim control.

How can I get more heat out of the appliance?

The most often cause of diminished heat output is overdue maintenance and cleaning. See “Maintaining and Servicing Appliance”.

What should I do if I smell smoke or there is ash/soot coming from the appliance?

While there will always be some smoke smell from wood burning appliances (including pellet) you should investigate all venting to make sure it is sealed properly. Most venting requires silicone to seal the seams.

In addition most homes are built very tight today and with exhaust systems can create negative pressure in the home. See “Negative Pressure” under “Getting Started” in the owner’s manual if you have checked the venting but still have smoke coming from the appliance. For ash or soot check the above and the exhaust blower housing and seals.

Why would my appliance run fine last winter but not start this fall?

It is possible that the stove was not properly prepared for the Non-burn season (see troubleshooting section).

Is there a place to lubricate the blowers to quiet them down?

No. The most often cause of noisy blowers is from the impellers becoming dirty over time. See maintenance and service section for maintaining and servicing.

What is the metal object with the bend in it that came inside the plastic bag?

It is a clean-out tool used to help clean the fire pot and remove any jams in the rare event they occur in the feed tube.

Why is there a black residue building up on the outside of my home?

Wind can cause this to happen. If the appliance is operating correctly very little soot should ever exit the termination cap. Check to be sure the venting is installed per the owner’s manual and local codes.

Do I need an outside air kit?

Outside air is required for mobile home installs and in some jurisdictions. Refer to “Listing & Code Approvals”, “Mobile Home Installation” and “Appliance Set-up”. Also refer to local building codes.

I am seeing sparks coming out of my pipe (termination cap) outside is this safe?

This is normal. As long as clearances to combustibles were followed this is safe.

I have no power to anything. Does this unit have a circuit breaker or fuse or a reset button?

This unit has one fuse on the control board and a resettable snap disc mounted to the feed tube. If the appliance overheats then the snap disc can be reset; if the fuse is blown the control board must be replaced.

Can I burn corn in my unit?

Yes, a 2:1 mix of pellets to corn is approved, but may require the fire pot to be cleaned more frequently. When using a pellet/corn fuel mixture, it is recommended that the trim adjustment is set to -4 (see pg. 13).

Where is the serial # located on my unit?

Freestanding - the serial number is located on the back of the stove.

No pellets are dropping in my fire pot.

See troubleshooting guide.

Contact your dealer for additional information regarding operation and troubleshooting.

Visit www.quadrafire.com to locate a dealer.

3 Maintenance and Service

When properly maintained, your appliance will give you many years of trouble-free service. **Contact your dealer** to answer questions regarding proper operation, troubleshooting and service for your appliance. Visit www.quadrafire.com to locate a dealer. We recommend annual service by a qualified dealer.

A. Proper Shutdown Procedure

Turn dial control to OFF, let appliance completely cool and exhaust blower must be off. After cooling unplug appliance before servicing.

This pellet heater has a manufacturer-set minimum low burn rate that must not be altered. It is against federal regulations to alter this setting or otherwise operate this pellet heater in a manner inconsistent with operating instructions in this manual.

B. Quick Reference Maintenance Chart

Cleaning or Inspection	Frequency		Daily	Weekly	Monthly	Yearly
Fire pot	As needed	OR	X			
Ash Removal from Firebox	About 5 bags of fuel depending on ash build-up	OR		X		
Glass	When clear view of fire pot becomes obscure	OR		X		
Hopper	Every ton of fuel (50 bags)	OR			X	
Exhaust Path, Drop Tube and Behind Baffles	Every ton of fuel (50 bags) or more frequently	OR			X	
Door Handle & Gasket Inspection	Prior to heating season	OR			X	
Blower, Convection	Every ton of fuel or more frequently depending on performance	OR			X	
Blower, Exhaust	Every ton of fuel or more frequently depending on performance	OR				X
Firebox - Prepare for Non-Burn Season	At end of heating season	OR				X
Venting System	Every 3 tons of fuel or more frequently depending on performance	OR				X

NOTICE: These are recommendations. When burning high ash content pellet fuel or a corn/pellet mix you may need to clean the fire pot several times a day. Clean the stove and fire pot more frequently if you encounter heavy build-up of ash at the recommended interval or you see soot coming from the vent. Not properly cleaning your appliance on a regular basis will void your warranty.

⚠ CAUTION



Shock and Smoke Hazard

- Smoke spillage into room can occur if appliance is not cool before unplugging.
- Risk of shock if appliance not unplugged before servicing appliance.

Follow the detailed instructions found in this section for each step listed as referenced in the chart below.

C. General Maintenance and Cleaning

1. Cleaning Fire pot using Lever

- **Frequency:** Daily or as needed*
- **By:** Homeowner

*When burning high ash content pellet fuel or a pellet/corn mix you may need to clean the fire pot several times a day.

- Be sure the appliance is allowed to cool.
- Open cast face of appliance
- Pull fire pot floor cleaning lever two times until the ash falls into the ash pan below. **Figure 17.2**
- It may be necessary to use your fire pot clean-out tool to chip away material that has built up on the sides of the fire pot and to push out any clinkers. **Figure 17.1**
- Larger clinkers may have to be removed from the top of the fire pot.
- If the clinker adheres to the sides of the fire pot, you will need to manually clean the fire pot. The fire pot floor plate must be fully closed when finished.

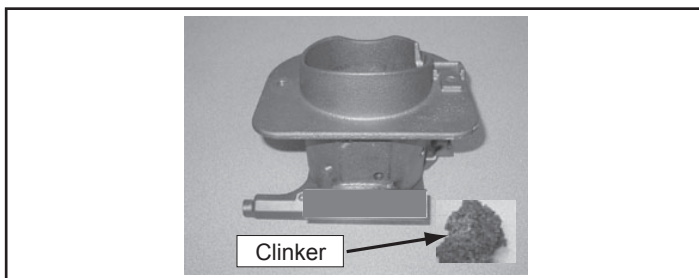

Figure 17.1 - Fire pot with large clinker

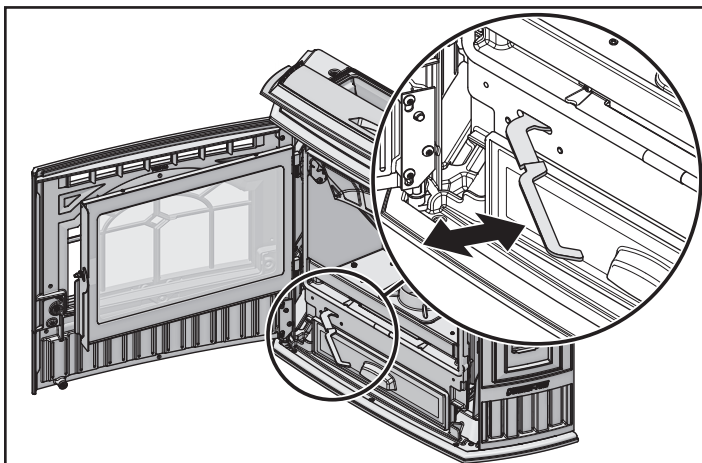

Figure 17.2

2. Cleaning Ash Pan

- **Frequency:** Weekly or every 3-5 bags
- **By:** Homeowner
 - Locate the ash pan underneath the fire pot.
 - Slide the ash pan straight out.
 - Empty into a non-combustible container and re-install ash pan.
 - When replacing ash pan push it back until it catches on the 2 side latches.

Clinkers filling the ash pan will have to be cleaned out more often than ash.

Ash Disposal:

Ashes should be placed in a steel container with a tight-fitting lid. The container of ashes should be moved outdoors immediately and placed on a non-combustible floor or on the ground, well away from combustible materials, pending final disposal.

If the ashes are disposed of by burial in soil or otherwise locally dispersed, they should be retained in the closed container until all cinders have thoroughly cooled. Other waste shall not be placed in this container.

3. Ash Removal from Firebox

- **Frequency:** Weekly or more frequently depending on ash build-up
- **By:** Homeowner
 - Be sure the appliance is allowed to cool.
 - There must not be any hot ashes in the firebox during cleaning.
 - Frequent cleaning of the ash in the firebox with a vacuum cleaner will help slow down the build-up of ash in the exhaust blower and vent system.

WARNING



RISK OF FIRE

Keep combustible materials, gasoline and other flammable vapors and liquids clear of appliance.

- Do NOT store flammable materials in the appliance's vicinity.

- Do NOT use gasoline, lantern fuel, kerosene, charcoal lighter fluid or similar liquids to start or "freshen up" a fire in this heater.

Keep all such liquids well away from the heater while it is in use as combustible materials may ignite.

4. Cleaning Heat Exchanger & Drop Tube

- **Frequency:** Monthly or every ton of fuel (50 bags).
- **By:** Homeowner

NOTE: Heavy duty vacuum cleaners may be obtained, specifically designed for solid fuel appliance cleaning.

MT. VERNON E2

Cleaning Heat Exchanger & Drop Tube (cont.)

Tools Needed: A Shop Vacuum and generic micro cleaning kit; flat head screwdriver; bottle brush, 1/2" ID hose.

- It is necessary to remove the baffle to gain access to the heat exchanger (figure 17.2). Follow instructions for baffle removal on **page 21, figure 21.2**.
- Vacuum the ash from the heat exchanger with an upholstery brush to remove the majority of the ash. Be sure to vacuum the back of the baffle also. Inspect the drop tube and remove any residue build-up in the drop tube. **Figure 18.3**
- Assemble the crevice tool from the micro cleaning kit to attach to a Shop Vac. **Figure 18.4**
- Use the crevice tool to finish cleaning the heat exchanger fins. It is critical that the 2 exhaust exits at the back of the firebox floor (left and right) be thoroughly cleaned. **Figure 17.2** There are several ways this can be done:
 - Use the crevice tool.
 - Attach a hose 1/2 inch (12.7mm) inside diameter and approximately 2 feet (607mm) in length to your vacuum hose.
 - Use a bottle brush and push the ash down to the bottom. Remove the combustion (exhaust) blower and then vacuum out the ash.

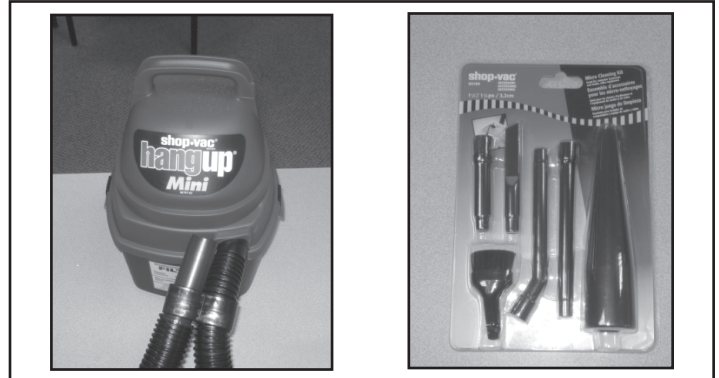

Shop Vacuum and Micro Cleaning Kit examples - items that can be purchased at local hardware stores.

** Can be purchased at your local hardware store.*

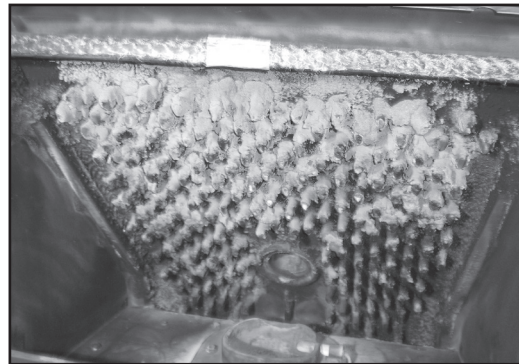

Figure 18.2 - Example of a dirty heat exchanger

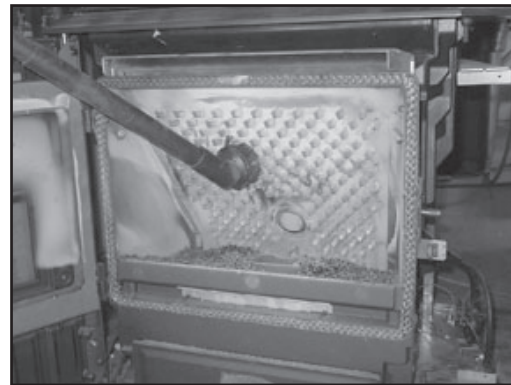

Figure 18.3

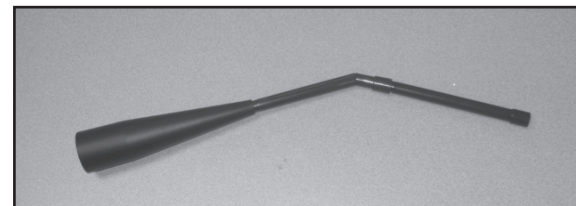

Figure 18.4

WARNING



Hopper Fire Risk!

For trouble free use of your pellet appliance you must perform cleaning as called for in these instructions. Not doing so will result in:

- Poor operating performance
- Smoke spillage into the home
- Overheating of components

Not properly cleaning your appliance on a regular basis will void your warranty.

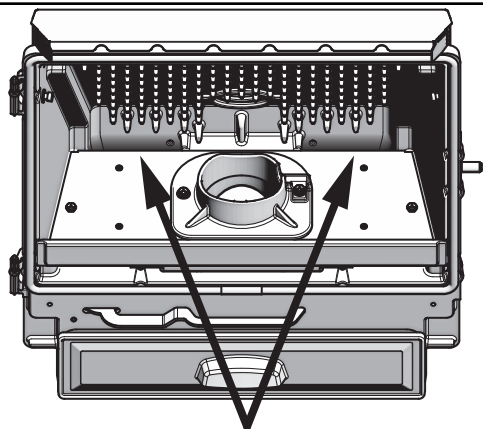

Exhaust exits must be thoroughly cleaned. Each exit is approximately 4 inches wide, 1 inch across, and 3 inches deep

Figure 18.1

5. Ash Removal System Inspection & Cleaning

- **Frequency:** Monthly or after burning 50 bags
 - **By:** Homeowner
- a. Be sure the appliance is allowed to cool.
 - b. Open the front cast door and cycle the ash removal handle - these should be inspected for functionality
 - c. Inspect for any degradation or deformation.
 - As the springs heat up and cool down they can lose tension
 - If there is a gap showing above the fire pot bottom, approximately 1/16 inch (1.59mm) or more, it means the springs have lost their tension
 - Lost tension cannot keep the floor in the proper position causing ignition problems and fuel falling into the ash pan. If noted, call your dealer to replace the springs.

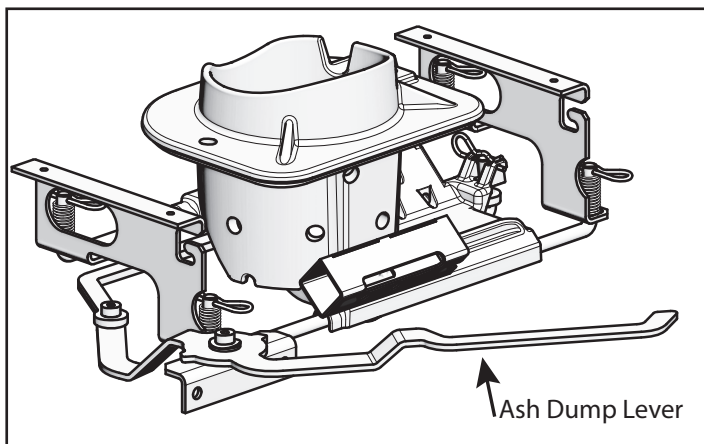

Figure 19.1

⚠ WARNING
<p>Risk of fire!</p> <p>Do NOT store fuel:</p> <ul style="list-style-type: none"> • Closer than required clearances to combustibles to appliance. • Within space required for loading or ash removal

6. Cleaning the Hopper

- **Frequency:** See chart on page 16
 - **By:** Homeowner
- a. Be sure the appliance is allowed to cool.
 - b. After burning approximately 1 ton of fuel you will need to clean the hopper to prevent sawdust and/or fines build-up.
 - c. A combination of sawdust/fines and pellets on the auger reduces the amount of fuel supply to the fire pot.
 - d. This can result in nuisance shut downs and mis-starts
 - Empty the hopper of any remaining pellets.
 - Vacuum the hopper and feed tube.

7. Cleaning the Glass

- **Frequency:** See chart on page 16
 - **By:** Homeowner
- a. Be sure the appliance is allowed to cool.
 - b. Clean glass with a non-abrasive commercially available cleaner. Wipe down with dry towel.

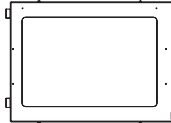
CAUTION	
	<p>Handle glass assembly with care.</p> <p>When cleaning glass door:</p> <ul style="list-style-type: none"> • Avoid striking, scratching or slamming glass. • Do NOT clean glass when hot. • Do NOT use abrasive cleaners. • Use a hard water deposit glass cleaner on white film. <p>Refer to maintenance instructions.</p>

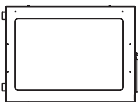
⚠ WARNING	
	<p>Handle glass doors with care.</p> <ul style="list-style-type: none"> • Inspect the gasket to ensure it is undamaged. • Do NOT strike, slam or scratch glass. • Do NOT operate appliance with glass door removed, cracked, broken or scratched.

8. Door Latch & Gasket Inspection

- **Frequency:** See chart on page 16
- **By:** Homeowner

The door latch is non-adjustable but the gasket between the glass and firebox should be inspected periodically to make sure there is a good seal. If the gasket is frayed or damaged, replace with a new one.

9. Cleaning Exhaust System (Requires No Lubrication)

- **Frequency:** See chart on page 16
 - **By:** Homeowner
- a. Be sure the appliance is allowed to cool.
 - b. Remove blower per replacement section instructions.
 - c. Use a soft brush and vacuum to clean the impeller.
 - d. Vacuum out exhaust path and housing. Figure 20.1
 - e. Replace fan (make sure elect connections are fully assembled)

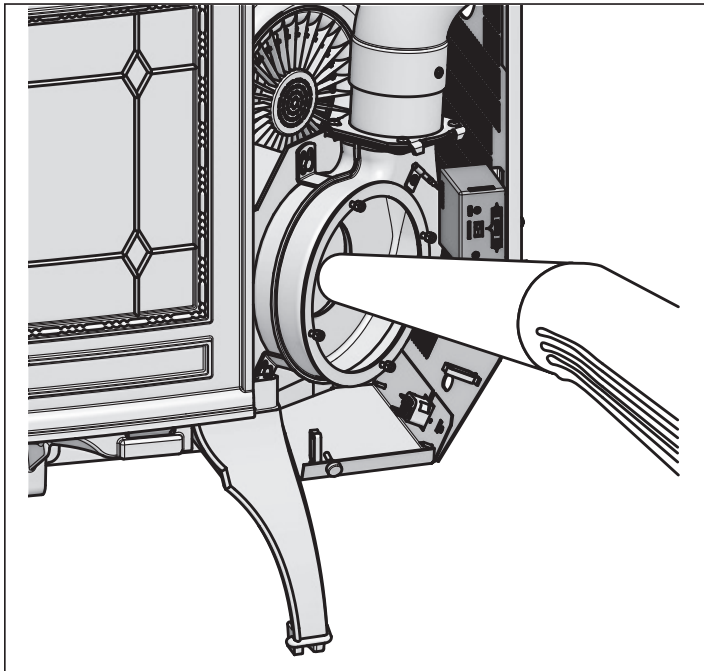

Figure 20.1

10. Cleaning Convection Blower Requires No Lubrication

- **Frequency:** See chart on page 16
 - **By:** Homeowner
- a. Be sure the appliance is allowed to cool.
 - b. Remove blower per replacement section instructions.
 - c. Use a soft brush and vacuum to clean the blower wheel.

11. Cleaning the Top Vent Adapter (if installed)

- **Frequency:** As needed
 - **By:** Homeowner
- a. Be sure the appliance is allowed to cool.
 - b. Open the clean out cover.
 - c. Sweep out any ash build-up.

12. Soot and Fly-ash: Formation & Need for Removal in Exhaust Venting System.

- **Frequency:** See chart on page 16
 - **By:** Qualified Service Technician and/or Homeowner
- a. The products of combustion will contain small particles of fly-ash. The fly-ash will collect in the exhaust venting system and restrict the flow of the flue gases. Incomplete combustion, such as occurs during startup, shut-down, or incorrect operation of the room heater will lead to some soot formation which will collect in the exhaust venting system.

Note: Ash will build up more quickly in the horizontal venting sections.

13. Preparing Firebox for Non-Burn Season

- **Frequency:** See chart on page 16
 - **By:** Homeowner
- a. The appliance must be in complete shutdown and allow the appliance to completely cool down.
 - b. Remove all ash from firebox and vacuum thoroughly.
 - c. To minimize corrosion, paint all exposed steel, including cast-iron. Use the Touch-Up paint supplied with the appliance or purchase paint from your local dealer. You must use a high-temperature paint made specifically for heating appliances.
 - d. Cleaning the flue at the end of the burn season will prevent corrosives to build-up and damage the flue.

D. Soot or Creosote Fire Awareness

The chimney should be inspected periodically during the heating season to determine if a creosote build-up has occurred. If a significant layer of creosote has accumulated (1/8 inch [3mm] or more) it should be removed to reduce the risk of chimney fire.

Check daily for creosote build-up until experience shows how often you need to clean to be safe. Be aware that the hotter the fire the less creosote is deposited, and weekly cleaning may be necessary in the mild weather even though monthly cleaning may be enough in the coldest months. Contact your local municipal or provincial fire authority for information on how to handle a chimney fire.

In the event of a soot or creosote fire, close the firebox door, exit the building immediately and contact the proper fire authorities.

DO NOT under any circumstances re-enter the building.

NOTE

- **This unit is required to be cleaned frequently because soot creosote and ash may accumulate.**

E. High Ash Fuel Content Maintenance

- **Frequency:** Daily
- **By:** Homeowner

If the ash build-up exceeds the half way point in the fire pot or if clinkers are adhering to the sides of the fire pot, the fire pot floor is not being cycled enough.

 **WARNING**

 **Risk of Fire and Smoke!**

- High ash fuels or lack of maintenance can cause fire pot to overflow. Follow proper shutdown procedure if ash buildup exceeds half way point in fire pot.
- Failure to do so could result in smoking, sooting and possible hopper fires.

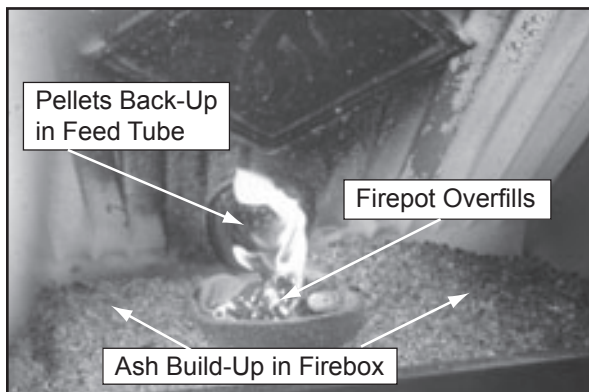



Figure 21.1

F. Baffle Removal

1. The appliance must be in complete shutdown, completely cool and the exhaust blower off.
 2. Open door.
 3. The baffle is located at the top inside of firebox.
 4. Remove baffle by placing a flat head screw driver into the slot of the latches located in the upper corners and rotate down. The bottom of the latch will fall forward off of the post. Lift the baffle up and then out toward you.
- Figure 20.2**
5. To replace the baffle, place the 2 locating ears behind the bottom edge and tilt the baffle up and into place.
 6. The baffle must be centered in the firebox before latching it in place. If it is not centered the latch will slip between the baffle and side of the firebox instead of latching properly.
 7. The bottom of the latches will fit over the posts. Using a screwdriver, rotate the top of the latch up to lock latch into place.

 **WARNING**

 **Cast iron is a very heavy material.** The baffle is made of cast iron and therefore is heavy and awkward at times to maneuver. Clear and prepare your work area before you begin.

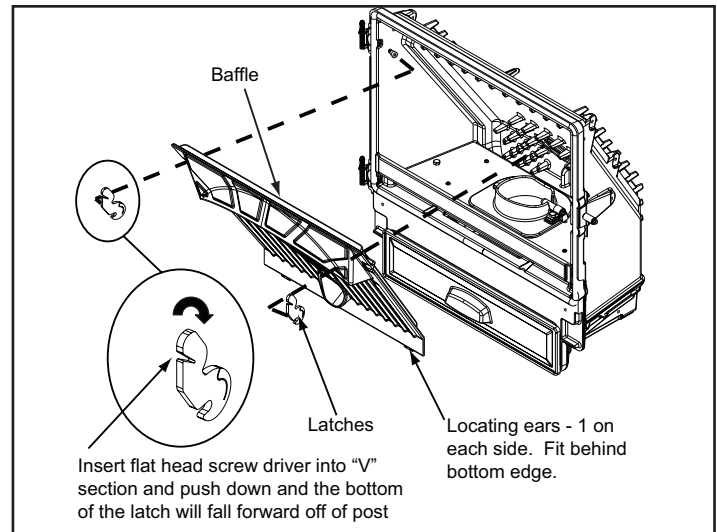

Figure 21.2

G. Glass Replacement

1. Swing open the face and remove the door from the appliance by lifting the door off of the hinge pins and lay on a flat surface face down.
2. Using a Phillips head screw driver, remove 4 screws, 2 on the top and 2 on the bottom. Remove metal bracket and then remove the glass. **Figure 20.3**
3. Replace with new glass with gasket.
4. Re-attach metal bracket with 4 screws.
5. Re-install door over hinge pins and close face.

 **WARNING**



- Glass is 5mm thick high temperature heat-resistant ceramic glass.
- **DO NOT REPLACE** with any other material.
- Alternate material may shatter and cause injury.

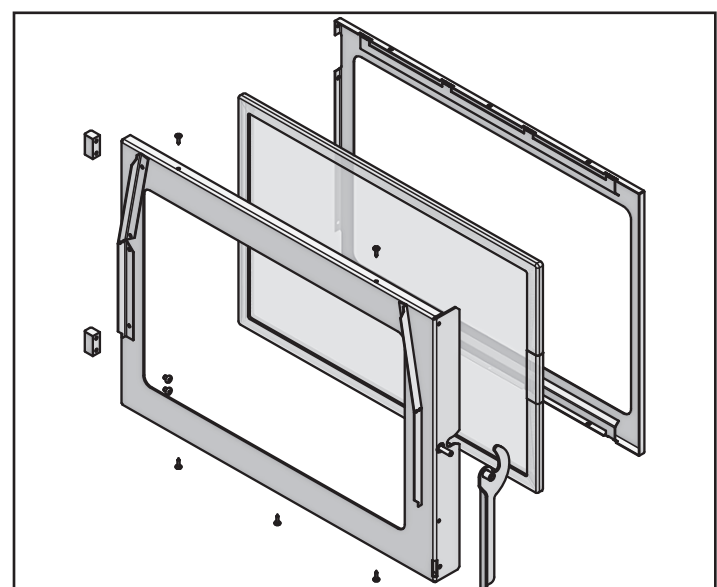

Figure 21.3

H. Convection Blower Replacement

1. Follow the proper shut down procedures.
2. Remove the left side panel by loosening the 2 screws using a Phillips head screw driver or wrench. **Figure 22.1**
3. Remove two lower sheet metal screws from the back panel to allow more clearance.
4. Disconnect the wire terminals.
5. Reach behind the blower and release the latch by pushing the top of the latch towards the blower. **Figure 22.1**
6. Rock the top of the blower slightly and lift up. The blower will pass out the left side of the appliance.

Note: You may need to loosen the surround to move it out of the way.

7. Install replacement blower by placing the bottom flange into the opening first then rotate blower up into position.
8. When the blower is properly positioned the latch will engage the notch to hold the blower in place. **Figure 22.1**
9. Re-connect wire terminals to the new blower.
10. Reposition and Re-secure the back panel.

Note: Make sure wires are connected prior to restarting the appliance. Failure to do so will result in the (side-mounted) safety thermal snap disc tripping resulting in cutting power to the appliance feed system.

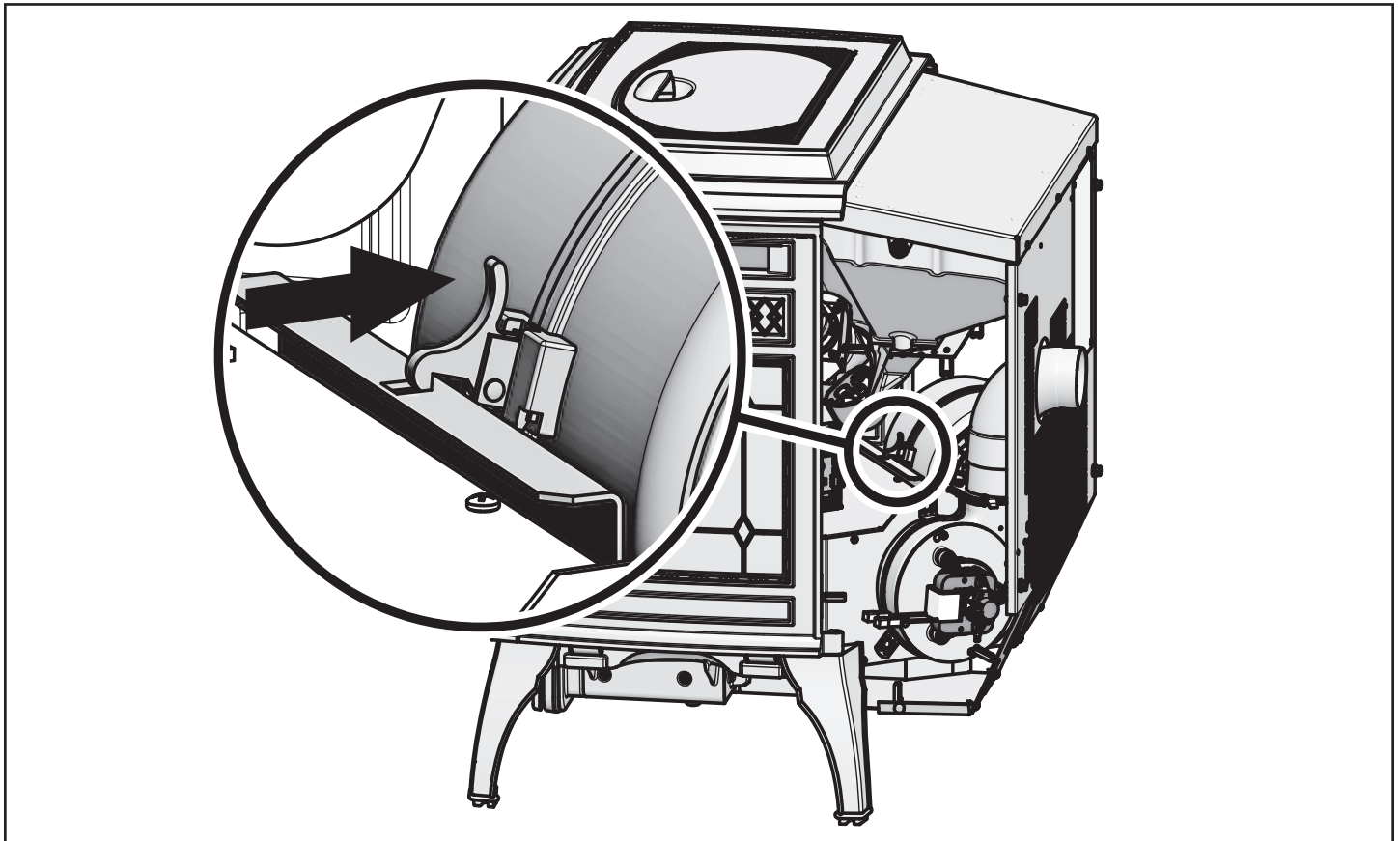

Figure 22.1

I. Combustion/Exhaust Blower Replacement

1. Follow the proper shut down procedures.
2. Remove the right side panel by loosening the 2 screws using a Phillips head screw driver or wrench. **Figure 23.1.**
3. It is not necessary or recommended to remove the housing to replace or service the combustion blower. You only need to remove the motor and impeller.
4. Disconnect the wire from the control board connection and hall effect switch/housing.
5. Using a 7mm socket wrench or nut driver, loosen the nuts securing the motor and impeller to the housing.
6. Holding the motor, rotate the mounting plate counter-clockwise and remove motor and impeller.
7. If the gasket between housing and motor is damaged it will have to be replaced. A gasket is included with the replacement blower.
8. Re-install in reverse order.

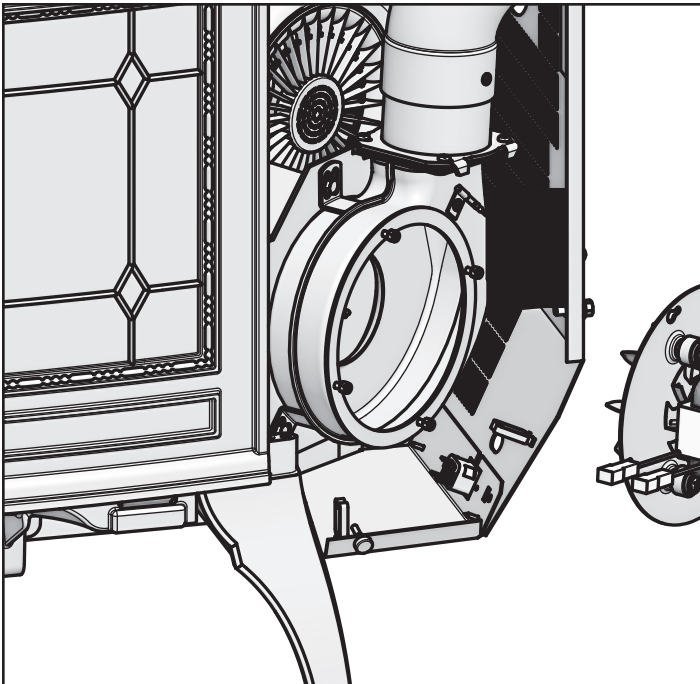

Figure 23.1

4 Troubleshooting Guide

With proper installation, operation, and maintenance your appliance will provide years of trouble-free service. If you do experience a problem, this troubleshooting guide will assist a qualified service person in the diagnosis of a problem and the corrective action to be taken. This troubleshooting guide can only be used by a qualified service technician.

Symptom	Possible Cause	Corrective Action
Plug in appliance - No response.	No Power to outlet.	Check circuit breaker at service panel.
	5 amp fuse blown	Replace control board - don't replace fuse
	Snap disc tripped or defective.	Reset or replace snap disc.
Unit will not light	No Fuel	Check hopper; load with wood pellets
	Vacuum switch not closing; no vacuum	Check vacuum switch wires are installed Check vacuum hose is connected to switch and feed tube port and is in good condition Make sure venting system is clean Make sure front door is closed Check vacuum tube for blockage or restrictions/kink
	Hopper lid open	Close hopper lid
	Defective hopper switch.	Check hopper switch operation Check hopper switch wires for integrity
	Safety snap disc is tripped	Check to make sure convection blower wires are connected and reset snap disc (located on RH side of appliance) Clean & inspect convection blower and convection air path.
	Feed System is jammed	Inspect and un-jam the feed assembly
	Feed motor not plugged in	Reconnect feed motor
	Igniter not plugged in	Connect the igniter wires
	Defective igniter	Replace igniter
	Fire pot plugged-up / dirty	Clean fire pot and movable floor Remove ash from the ash pan
Fire starts but goes out	Dial control is set to "OFF"	Turn dial control (on the appliance) to a setting other than OFF
	Dirty fire pot, exhaust path, and/or venting plugged	Clean fire pot and movable floor Inspect and clean exhaust path and venting Clean firebox, exhaust path, and venting (including behind baffle)
	Exhaust sensor cannot read temperature or is loose	Secure the exhaust probe to exhaust blower housing – keeping its wire away from hot surfaces
	Exhaust plenum is dirty	Clean exhaust path to plenum
	Exhaust probe is defective (error code may result)	Check for probe wire integrity and/or replace defective exhaust probe securing the exhaust probe to exhaust blower housing – keeping its wire away from hot surfaces

Symptom	Possible Cause	Corrective Action
Appliance starts and stops frequently when operating in the mode	Area where the thermostat is placed affects temperature.	Check thermostat proximity to doors and windows
	Thermostat located in tight spaces effecting the on/off cycling of the appliance.	Inspect thermostat location and make sure it is not close to a surface that heats and cools quickly.
Slow or smoky start-up and/or lazy flame	Dirty fire pot, exhaust path, and/or venting system.	Clean entire appliance including: fire pot, ash build up in firebox, fire pot area, behind baffle, firebox, exhaust blower, venting, and ash pan.
	Not enough combustion air	Adjust the trim (see trim adjustment section)
	Misaligned igniter	Center the igniter in the chamber
	Wet fuel or poor quality fuel	Replace wood pellet fuel
Convection blower fails to start	Convection Blower is jammed	Clean and un-jam the blower
	Not electrically connected	Connect the blower wires to its respective power wires
	Blower is defective	Replace blower
	Exhaust probe not sensing correct temperature	Secure the exhaust probe to exhaust blower housing – keeping its wire away from hot surfaces
	Control board is defective.	Replace control board
Convection Blower fails to shut off	Wire short between blower and ground - Control board is defective	Repair wire and replace control board
Exhaust blower fails to start and/or red flashes 6X – indicating a exhaust encoder alarm.	Exhaust blower is jammed	Clean, and un-jam the blower
	Not electrically connected	Connect the blower wires to its respective power wires
	Blower is defective	Replace blower
	Control board or dial control is defective.	Unplug dial control, if exhaust blower runs, dial control is defective. If exhaust blower <i>does not</i> run with dial control unplugged, replace control board.
Exhaust Blower fails to shut off	Wire short between blower and ground - Control board is defective	Repair wire and replace control board
Feed Motor fails to shut off	Wire short between ground and: feed motor, vacuum switch, hopper switch, or safety snap disc	Repair wire(s) and replace control board
	Control board is defective	Replace control board
Convection Blower makes noise	Convection blower is dirty causing an out-of-balance condition	Clean blower impellers
Igniter does not turn off	Wire short between igniter and ground – Control board is defective	Repair wire and replace control board

Symptom	Possible Cause	Corrective Action
Large, lazy flame (orange color) with black ash / soot buildup on glass	Dirty appliance or venting	Clean unit including the fire pot, exhaust path, and venting system
	Poor fuel quality, high ash content.	Purge old fuel and use higher quality / or brand of fuel
	Incorrect air-fuel adjustment	Adjust the trim (see trim adjustment section)
	Excessive feeding	Adjust trim per trim dial instructions
	Feed Motor locked on	Follow corrective action for feed motor not turning off
Excessive fuel spilling over the fire pot and/or excessive flame	Dirty Appliance	Clean unit including the fire pot, exhaust path, and venting system
	Feed Motor locked on	Follow corrective action for feed motor not turning off
Black soot on the side of the house	Dirty Appliance	Clean unit including the fire pot, exhaust path, and venting system
	Exhaust termination cap too close to the structure	Extend the termination further from the structure
	Excessive feeding (incorrect air-fuel ratio)	Adjust the trim (see trim adjustment section)
Unit rumbles consistently during burns	Too much fuel	Turn trim dial counterclockwise one notch at a time
	Too much air	Turn trim dial towards the zero setting one notch at a time
	Note: Refer to trim setting section for more information, page 12.	

Following correction of any Alarm, turn the dial control to the OFF position, wait 10 seconds and turn back to desired setting OR unplug the unit, wait 10 seconds then restore power.

Alarm (LED Flashing RED)	Possible Cause	Corrective Action
1 Red Flash: Empty Hopper Alarm	Hopper empty	Fill the hopper
	Auger jam	Inspect the feed tube for jams
	Vacuum switch not closing	Make sure firebox door is shut, vacuum hose is connected to switch and drop tube, wire connectors are connected to vacuum switch, control board, hopper switch, and safety snap disc.
	Hopper lid open	Close the hopper lid
	Exhaust probe does not sense temperature	Secure the exhaust probe keeping its wire away from hot surfaces and clean the exhaust plenum
	Snap disc tripped	Reset snap disc
	Exhaust probe not attached to exhaust blower properly	Secure exhaust probe to exhaust blower housing – keeping its wire away from hot surfaces
	Exhaust path is dirty	Clean unit including the fire pot, exhaust path, and venting system
2 Red Flashes: Exhaust Probe Fail	Not connected to the control board	Connect terminal end to control board
	Failed component	Replace exhaust probe – securing it to exhaust blower housing – keeping wire away from hot surfaces
4 Red Flashes: Missed Ignition	Hopper empty	Fill the hopper
	Feed motor doesn't turn	Inspect feed motor circuit (hopper lid must be closed, vacuum switch must be closed, snap disc closed, and feed motor must be plugged in) Clear jam in feed tube
	Dirty appliance	Clean unit including the fire pot, exhaust path, and venting system
	Igniter has no power or is defective	Check igniter lead connections or replace igniter
	Exhaust probe not properly installed	Secure exhaust probe to exhaust blower housing – keeping its wire away from hot surfaces
	Igniter chamber plugged with debris	Clean igniter chamber
6 Red Flashes: Exhaust Blower Alarm	Wire from exhaust blower or encoder is disconnected or shorted	Make sure wire is not damaged / melted and ends are fully connected to the encoder and control board.
	Defective exhaust blower	Replace exhaust blower
	Defective encoder (on end of exhaust blower)	Replace exhaust blower
8 Red Flashes: Exhaust Over-Temp	Feed Motor Locked On	Repair wire(s) and replace control board
	Non-approved fuel used	Only use wood pellet fuel. Do not enhance its performance with any other combustible substance.
	Convection blower dirty	Clean impellers

5 Reference Materials

A. Component Functions



When describing the location of a component, it is always AS YOU FACE THE FRONT OF THE APPLIANCE.

1. Exhaust Blower

The combustion (exhaust) blower is mounted in the bottom right rear of appliance. The blower is designed to pull the exhaust from the appliance and push it out through the venting system.

2. Control Board

The control board is located on the right side of appliance. It controls the functioning of the appliance and communicates with the dial control. The control board can only be replaced by an authorized dealer.

3. Convection Blower

The convection blower is mounted at the bottom left of the appliance. The convection blower pushes heated air through the heat exchange system into the room.

4. Feed System

The feed system is located on the right side of the appliance and can be removed as an entire assembly. The hollow feed spring (auger) pulls pellets up the feed tube from the hopper area and drops them down the feed chute into the fire pot. Reference the parts list for individual parts in feed assembly .

5. Fire pot

The fire pot is made of high quality ductile iron. The floor of the fire pot opens for cleaning and is manually operated by the homeowner. The floor needs to return to a completely closed position or the appliance will not operate properly.

6. Fuse

The control board fuse will blow should a short occur. The control board will need to be replaced. DO NOT REPLACE THE FUSE. If the control board fuse blows its TRIAC, that portion of the circuit, will remain closed causing the motor on that leg to run continuously at high speed.

7. Heat Exchanger

The heat exchanger is located behind the baffle and transfers heat from the exhaust system into the convection air chamber. Remove the cast iron baffle to access the heat exchanger.

8. Hopper Lid Switch

The hopper lid switch is located on the right side, inside the hopper. It switches the feed motor off if the hopper lid is open.

9. Igniter (Heating Element)

The igniter is mounted on the base of the fire pot. Combustion air travels over the red hot igniter creating super heated air that ignites the pellets.

10. Power Receptacle

The power receptacle is located below the control box on right side. Install the power cord (supplied in the appliance component pack) to the appliance receptacle. Prior to installing, check the wall receptacle for 120 volt, 60 Hz (standard current). Make sure the outlet is grounded and has the correct polarity. A good quality surge protector is highly recommended to protect the appliance electronics.

11. Overheat Snap Discs

There are two overheat snap discs located within the electro-mechanical cavity of the appliance. One is mounted on the back of the drop tube in the center of the appliance; the other is mounted in the RH side between the firebox and cast side panel. Both snap discs have a reset button. If the fire tries to

burn back into the feed system, the drop tube snap disc will shut the appliance down. If there is not enough circulation from the convection blower the second snap disc will shut the feed system off. Either sensor must be manually re-set if tripped. Disconnect power before resetting.

12. Exhaust Probe - Exhaust Blower

The exhaust probe is a temperature-sensing device attached to the exhaust blower housing via screw and clamp. It provides sympathetic exhaust temperature feedback to the control board. In turn, the control board uses this information to adjust its heat-output systems for best performance.

13. Vacuum Switch

The vacuum switch is located on the right side of the appliance under the feed motor, behind right side panel. Its vacuum hose connects to the drop tube. This switch turns the feed system on when vacuum is present in the firebox. The vacuum switch is a safety device to shut off the feed motor if the exhaust or the heat exchanger system is dirty, plugged, or if the firebox door is open.

14. Wiring Schematic for Control Board (below)

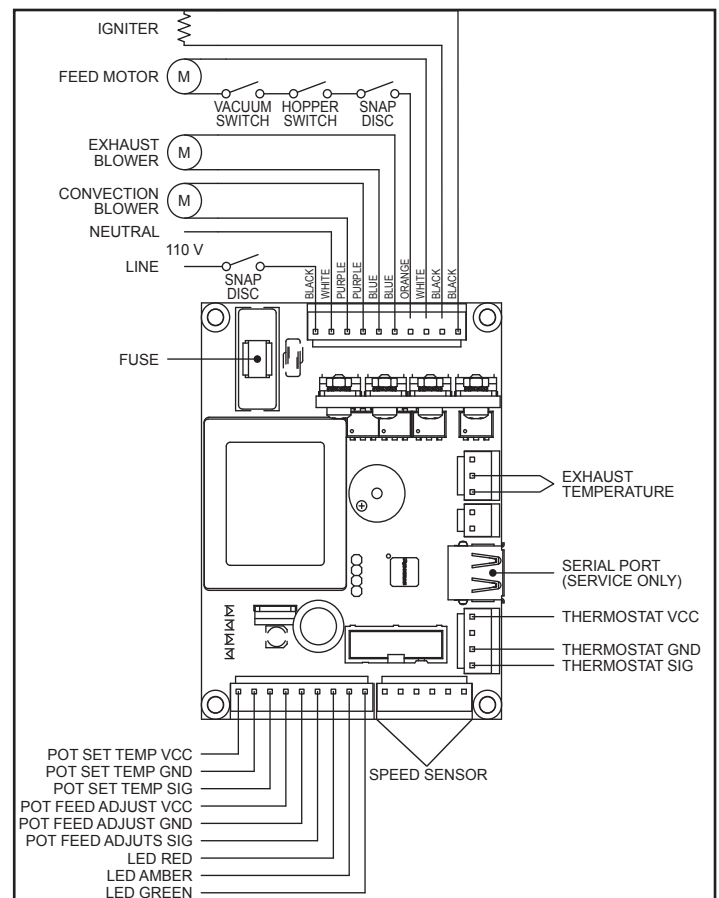

Figure 28.1 - Control Board Schematic

C. Exploded Drawings



MT VERNON E2

Beginning Manufacturing Date: Feb 2014
Ending Manufacturing Date: Active

MTV-E2-CSB, MTV-E2-MBK, MTV-E2-PBK, MTV-E2-PDB, MTV-E2-PFT, MTV-E2-PMH

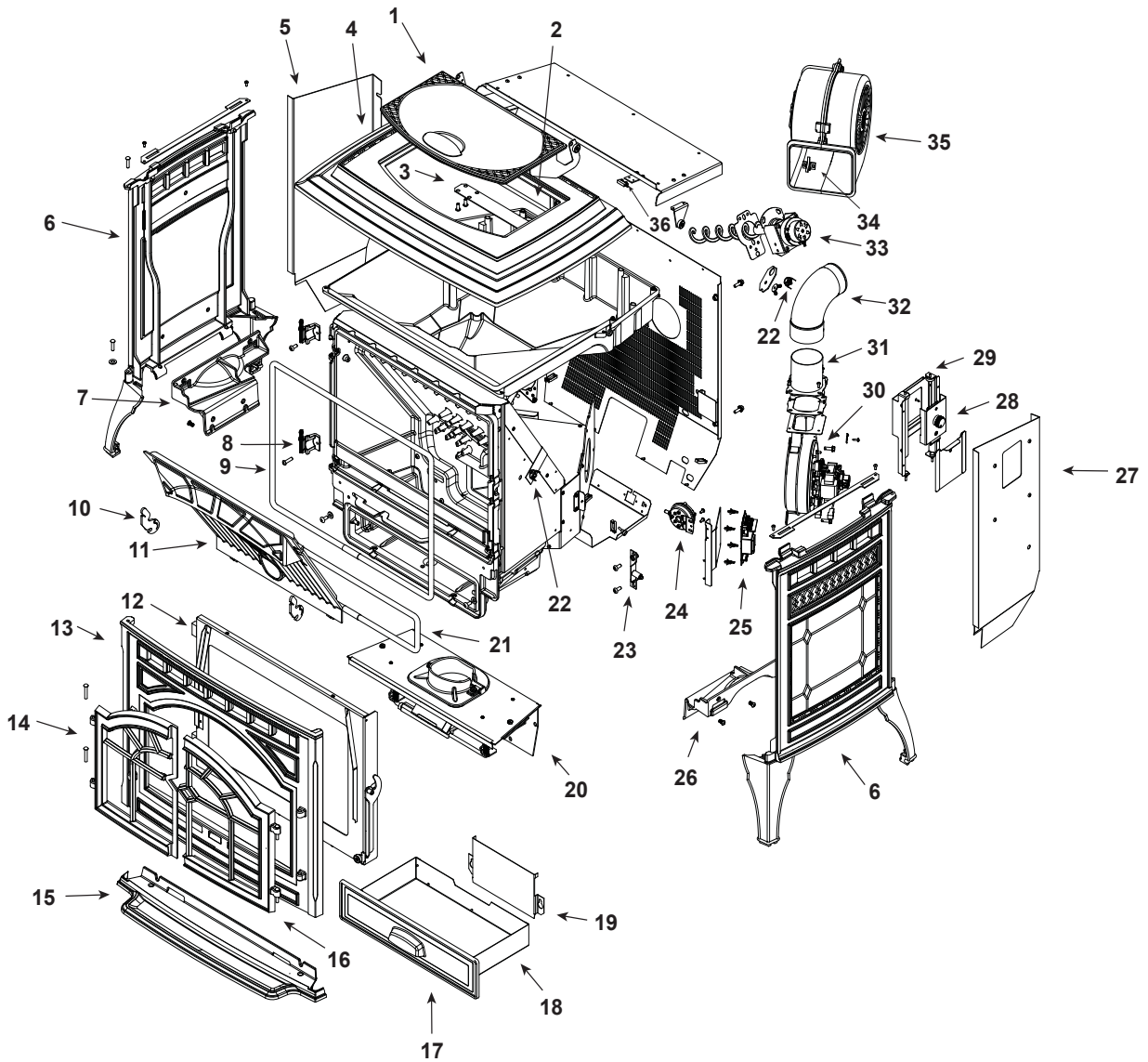

Part number list on following page.

04/17

D. Parts List



MT VERNON E2

Beginning Manufacturing Date: Feb 2014
Ending Manufacturing Date: Active

IMPORTANT: THIS IS DATED INFORMATION. Parts must be ordered from a dealer or distributor. **Hearth and Home Technologies does not sell directly to consumers.** Provide model number and serial number when requesting service parts from your dealer or distributor.



Stocked at Depot

ITEM	DESCRIPTION	COMMENTS	PART NUMBER	
1	Hopper Lid	Matte Black	7034-157MBK	
		Porcelain Black	7034-157PBK	
		Porcelain Dark Blue	7034-157PDB	
		Porcelain Frost	7034-157PFT	
		Porcelain Mahogany	7034-157PMH	
		Sienna Bronze	7034-157CSB	
	Gasket, Hopper Lid	10 FT	7000-320/10	
2	Hinge Pin		SRV7034-159	
3	Hinge Retainer		SRV7034-163	
4	Top	Matte Black	7034-155MBK	
		Porcelain Black	7034-155PBK	
		Porcelain Dark Blue	7034-155PDB	
		Porcelain Frost	7034-155PFT	
		Porcelain Mahogany	7034-155PMH	
		Sienna Bronze	7034-155CSB	
5	Shroud Left		SRV7080-123	
6	Side (Interchangeable)	Matte Black	7005-107MBK	
		Porcelain Black	7005-107PBK	
		Porcelain Dark Blue	7005-107PDB	
		Porcelain Frost	7005-107PFT	
		Porcelain Mahogany	7005-107PMH	
		Sienna Bronze	7005-107CSB	
7	Side Mount Left		7034-128	
8	Hinge Male		SRV7034-138	
9	Gasket, Door Rope		SRV7034-177	Y
10	Latch, Baffle		SRV7034-149	
11	Baffle		SRV7034-263	Y

Additional service part numbers appear on following page.

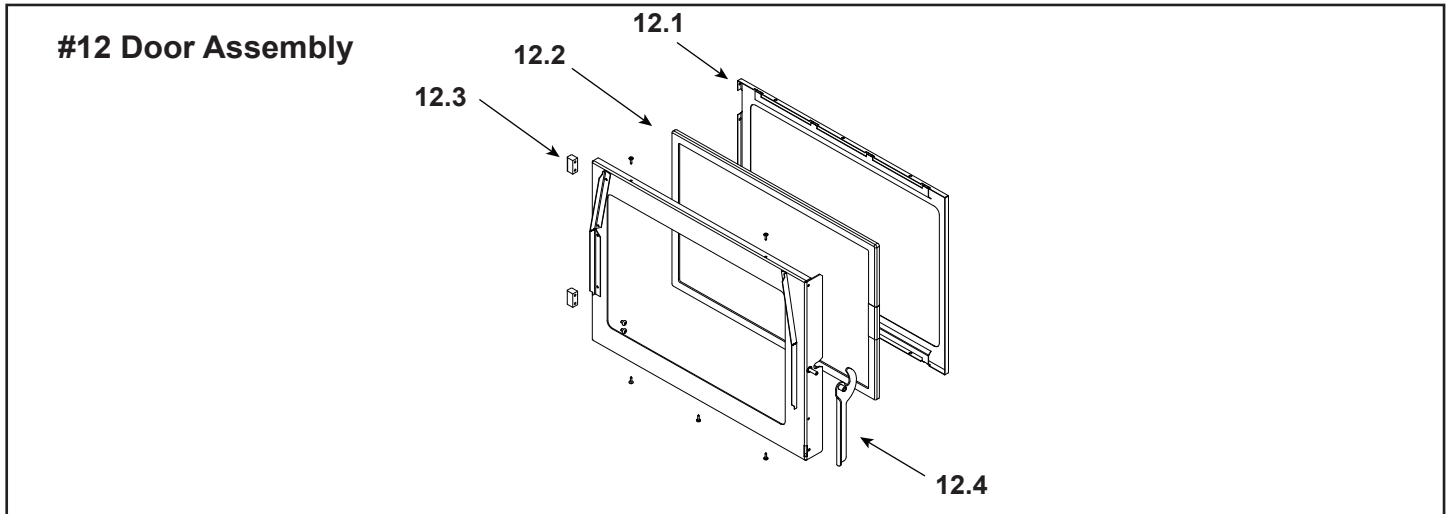

IMPORTANT: THIS IS DATED INFORMATION. Parts must be ordered from a dealer or distributor. **Hearth and Home Technologies does not sell directly to consumers.** Provide model number and serial number when requesting service parts from your dealer or distributor.



Stocked at Depot

ITEM	DESCRIPTION	COMMENTS	PART NUMBER	
12	Door Assembly		SRV7080-015	
12.1	Glass Retainer		7034-136	Y
12.2	Glass Assembly w/Gasket		7034-007	Y
	Gasket, Channel 1/8 x 1-1/4 x 10		7000-377/10	
12.3	Hinge Female		SRV450-2910	
12.4	Door Latch Assembly		413-5200	
13	Front, Face	Matte Black	7005-108MBK	
		Porcelain Black	7005-108PBK	
		Porcelain Dark Blue	7005-108PDB	
		Porcelain Frost	7005-108PFT	
		Porcelain Mahogany	7005-108PMH	
		Sienna Bronze	7005-108CSB	
	Rivet, Button Head	Pkg of 25	25272/25	Y
14	Door Left	Matte Black	7005-110MBK	
		Porcelain Black	7005-110PBK	
		Porcelain Dark Blue	7005-110PDB	
		Porcelain Frost	7005-110PFT	
		Porcelain Mahogany	7005-110PMH	
		Sienna Bronze	7005-110CSB	
15	Ash Lip	Matte Black	7080-140MBK	
		Porcelain Black	7080-140PBK	
		Porcelain Dark Blue	7080-140PDB	
		Porcelain Frost	7080-140PFT	
		Porcelain Mahogany	7080-140PMH	
		Sienna Bronze	7080-140CSB	

Additional service part numbers appear on following page.

IMPORTANT: THIS IS DATED INFORMATION. Parts must be ordered from a dealer or distributor. **Hearth and Home Technologies does not sell directly to consumers.** Provide model number and serial number when requesting service parts from your dealer or distributor.



Stocked at Depot

ITEM	DESCRIPTION	COMMENTS	PART NUMBER	
16	Door Right	Matte Black	7005-109MBK	
		Porcelain Black	7005-109PBK	
		Porcelain Dark Blue	7005-109PDB	
		Porcelain Frost	7005-109PFT	
		Porcelain Mahogany	7005-109PMH	
		Sienna Bronze	7005-109CSB	
17	Ash Pan Door		7034-133	
18	Ash Pan Assembly		SRV7034-069	
	Twin Ball Catch		SRV7000-532	Y
19	Intake Shield		7034-224	Y

#20 Firepot Riser Assembly

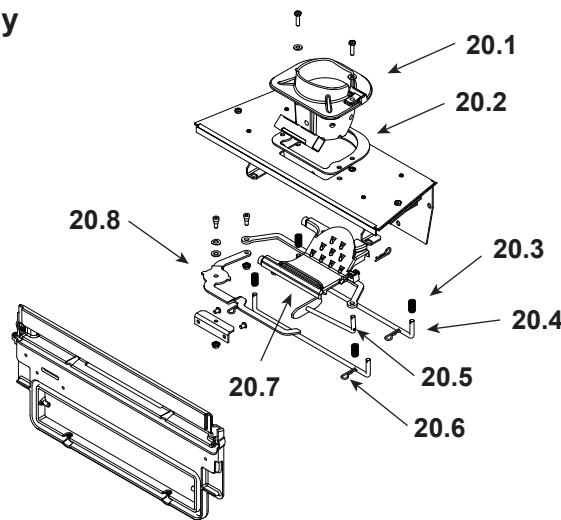

20	Firepot Riser Assembly		SRV7080-002	
20.1	Firepot Assembly		SRV7034-072B	Y
20.2	Gasket, Firepot		SRV7034-190	Y
20.3	Spring	Pkg of 4	7000-513/4	Y
20.4	Rail, Auto-clean		SRV7034-152	Y
20.5	Plow Weldment, Auto-clean		SRV7034-024	Y
20.6	Hitch Pin Clip, 3/32	Pkg of 10	7000-374/10	Y
20.7	Firepot Bottom		SRV7034-153	Y
20.8	Firepot Floor Lever Assembly		SRV7080-018	
21	Gasket, Rope, Ash Door		SRV7034-178	Y
22	Snap Disc, L250F Manual Reset		SRV230-1290	Y
23	Latch Bracket Assembly		SRV7034-049	Y

Additional service part numbers appear on following page.

QUADRA-FIRE® Service Parts

MT VERNON E2

Beginning Manufacturing Date: Feb 2014
Ending Manufacturing Date: Active

IMPORTANT: THIS IS DATED INFORMATION. Parts must be ordered from a dealer or distributor. **Hearth and Home Technologies does not sell directly to consumers.** Provide model number and serial number when requesting service parts from your dealer or distributor.



**Stocked
at Depot**

ITEM	DESCRIPTION	COMMENTS	PART NUMBER	
	Component Pack Assembly	Matte Black	SRV7080-040	
		Porcelain Black	SRV7080-043	
		Porcelain Dark Blue	SRV7080-044	
		Porcelain Frost	SRV7080-045	
		Porcelain Mahogany	SRV7080-042	
		Sienna Bronze	SRV7080-041	
	Cleanout Tool		414-1140	Y
	Leveling Assembly		7000-000	
	Paint Touch-Up	Matte Black	812-0910	
		Porcelain Black	1-00-0022	
		Porcelain Dark Blue	1-00-0020	
		Porcelain Frost	1-00-0021	
		Porcelain Mahogany	855-1450	
		Sienna Bronze	TOUCHUP-CSB	
	Power Cord		812-1180	Y
	Exhaust Probe		SRV7000-669	
	Heating Element Assembly 18", 120 VAC, 300 Watt, (Wood Pellet Fuel Only)		SRV7000-647	Y
		Pkg of 10	SRV7000-647/10	Y
	Wing Thumb Screw 8-32 X 1/2	Pkg of 24	7000-223/24	Y
	Wire Clip	Pkg of 10	7000-400/10	Y
ACCESSORIES				
	Collar, Offset, Top Vent		812-3570	
	Damper, 3 Inch - Tall Vertical Installs Only		PEL-DAMP3	Y
	Damper, 4 Inch - Tall Vertical Installs Only		PEL-DAMP4	
	Firescreen	No Longer Available	SCR-7005	
	Log Set, (Sold as Set only)	2 Pc	LOGS-60-AE-B	
	Outside Air Kit		OAK-3	
	Top Vent Adapter		TPVNT-3	
	Warming Shelves	No Longer Available	844-9780	
		Porcelain Black	WSLG-PBK	
		Porcelain Dark Blue	WSLG-PDB	
		Porcelain Frost	WSLG-PFT	
		No Longer Available	844-9810	
		Sienna Bronze	WSLG-CSB	



CONTACT INFORMATION

Hearth & Home Technologies
352 Mountain House Road
Halifax, PA 17032
Division of HNI INDUSTRIES

**Please contact your Quadra-Fire dealer with any questions or concerns.
For the number of your nearest Quadra-Fire dealer
log onto www.quadrafire.com**

CAUTION



DO NOT DISCARD THIS MANUAL

Important operating and maintenance instructions included.

• Read, understand and follow these instructions for safe installation and operation.

• Leave this manual with party responsible for use and operation.



We recommend that you record the following pertinent information for your heating appliance.

Date purchased/installed: _____

Serial Number: _____ Location on appliance: _____

Dealership purchased from: _____ Dealer phone: 1(____) _____ - _____

Notes: _____

This product may be covered by one or more of the following patents: (United States) 5341794, 5263471, 6688302, 7216645, 7047962 or other U.S. and foreign patents pending.

