

Owner's Manual

Operation & Care

INSTALLER: Leave this manual with party responsible for use and operation.

OWNER: Retain this manual for future reference.

Contact your dealer with questions on installation, operation, or service.

NOTICE: DO NOT DISCARD THIS MANUAL

QUADRA-FIRE

**41-I ACC WOOD INSERT
Automatic Combustion Control (ACC)**

**Model(s):
41I-ACC**

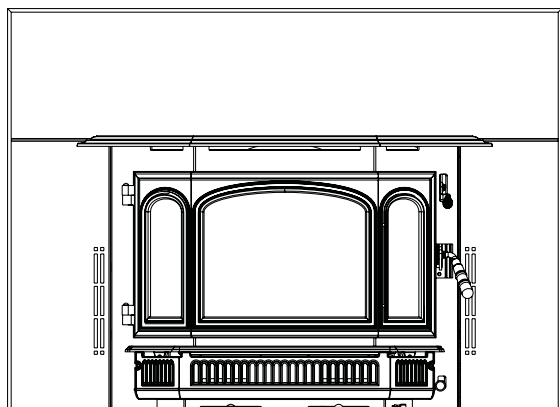

WARNING



If the information in these instructions is not followed exactly, a fire may result causing property damage, personal injury, or death.

- Do not store or use gasoline or other flammable vapors and liquids in the vicinity of this or any other appliance.
- Do not overfire - If heater or chimney connector glows, you are overfiring. Overfiring will void your warranty.
- Comply with all minimum clearances to combustibles as specified. Failure to comply may cause house fire.

WARNING



HOT SURFACES!

Glass and other surfaces are hot during operation AND cool down.

Hot glass will cause burns.

- Do not touch glass until it is cooled
- NEVER allow children to touch glass
- Keep children away
- CAREFULLY SUPERVISE children in same room as fireplace.
- Alert children and adults to hazards of high temperatures
- **High temperatures may ignite clothing or other flammable materials.**
- Keep clothing, furniture, draperies and other flammable materials away.

WARNING



Fire Risk.

For use with solid wood fuel only.
Other fuels may overfire and generate poisonous gases (i.e. carbon monoxide).

**myhht
FACTORY
training**

Installation and service of this appliance should be performed by qualified personnel. Hearth & Home Technologies recommends HHT Factory Trained or NFI certified professionals.



NOTE

To obtain a French translation of this manual, please contact your dealer or visit www.quadrafire.com

Pour obtenir une traduction française de ce manuel, s'il vous plaît contacter votre revendeur ou visitez www.quadrafire.com

Congratulations

and Welcome to the Quadra-Fire Family!

A. Congratulations

Hearth & Home Technologies welcomes you to our tradition of excellence! In choosing a Quadra-Fire appliance, you have our assurance of commitment to quality, durability, and performance.

This commitment begins with our research of the market, including 'Voice of the Customer' contacts, ensuring we make products that will satisfy your needs. Our Research and Development facility then employs the world's most advanced technology to achieve the optimum opera-

tion of our stoves, inserts and fireplaces. And yet we are old-fashioned when it comes to craftsmanship. Each unit is meticulously fabricated and gold and nickel surfaces are hand-finished for lasting beauty and enjoyment. Our pledge to quality is completed as each model undergoes a quality control inspection.

We wish you and your family many years of enjoyment in the warmth and comfort of your hearth appliance. Thank you for choosing Quadra-Fire.

NOTE: Clearances may only be reduced by means approved by the regulatory authority having jurisdiction

B. Sample of Serial Number/Safety Label
 LOCATION: UNDER ASH LIP ON PULL-OUT PLATE

SAMPLE

INSTALLATION MANUAL

LISTED ROOM HEATER,
SOLID FUEL TYPE.
***For Use with Solid Wood Fuel Only.**
Also for use in Mobile Home.
PREVENT HOUSE FIRES

OWNERS MANUAL

Install and use only in accordance with manufacturer's installation, venting and operating instructions.

CONTACT YOUR LOCAL BUILDING OR FIRE OFFICIALS ABOUT RESTRICTIONS AND INSTALLATION INSPECTION IN YOUR AREA

Refer to manufacturer's instructions and local codes for precautions required for passing chimney through a combustible wall or ceiling.

WARNING - For Mobile Homes: Do not install in a sleeping room. An outside combustion air inlet must be provided and unrestricted while unit is in use. The structural integrity of the mobile home floor, ceiling and walls must be maintained. The insert must be properly grounded to the frame of the mobile home. A complete rerouting of the chimney system with a 6 inch (152mm) diameter listed stainless liner is required. Insert must be equipped with a spark arrestor cap. Outside Air comes standard on the insert and is installed before operating insert.

When used as a masonry insert stove, install only in a masonry fireplace built to meet and/or local codes. Do not remove brick or mortar to accommodate insert. Installation requires a 5 foot minimum length of a starter pipe into existing chimney with airtight face seal.

Install only on a non-combustible hearth. Approve installation on factory built zero-clearance fireplaces conforming to minimum fire clearance specifications. Components required for installation: pipe, pipe, pipe, connection assembly or listed vent liner.

In Canada a full length 6 inch (152mm) stainless steel pipe is required as per ULC S628-93.

WARNING - Inspect and clean chimney frequently. Under certain conditions of use, creosote buildup may occur rapidly.

Do not connect this unit to another appliance.

DANGER - Risk of fire or explosion. Do not connect power supply before servicing. Route power cord away from the unit. Do not place cord under or in front of appliance.

Electrical Rating: 115 Volts, 60 Hz

Do not use alcohol, kerosene, or other flammable liquids.

Do not place anything on hearth (table, etc.) that may overfire. If heater or safety connector gloves, you are overheat. Operate only with doors closed. Open only to add fuel to the fire. Replace glass only with 5mm ceramic available from your dealer.

This wood heater needs periodic inspections and repair for proper operation. Consult the owner's manual for further information. It is against federal regulations to operate this wood heater in a manner inconsistent with the operating instructions in the owner's manual.

Factory-Built Floor
Protection under Hearth Extension
Thermal & Ember Protection.
Floor height 0 to 1-3/4 inches below Insert
Base: 1/2 inch R=2.38

Ember Protection Only
Greater than 1-3/4 inches below Insert
Base:

Hearth Extension

Minimum Clearances To Combustible Material
Masonry, Heat Circulating & Factory-Built
Refer to Clearances on other label for Canada

	USA ONLY
A: Sidewall to Fuel Loading Door	22 in.
B: Mantel to Top of unit	23 in.
C: Top Trim to Top of unit	21 in.
D: Side Trim to Fuel Loading Door	11 in.
E: Hearth Extension from Glass	16 in.
F: Hearth Extension from Fuel Loading Door	8 in.

CAUTION: HOT WHILE IN OPERATION DO NOT TOUCH, KEEP CHILDREN, CLOTHING AND FURNITURE AWAY. CONTACT MAY CAUSE SKIN BURNS. SEE NAMEPLATE AND INSTRUCTIONS.

QUADRA-FIRE
Intertek
4001508
CONFORMS TO UL STD 1482
CERTIFIED TO UL STD 8628

Serial No. **007027**

Model: **41001-ACC**
WOOD INSERT

Serial Number

Model Name

Mfg by: HEARTH & HOME TECHNOLOGIES 1446 N. Highway, Colville, WA 99114 www.quadrafire.com
 U.S. ENVIRONMENTAL PROTECTION AGENCY - Certified to comply with 2015 particulate emission standards at 4.3 g/hr EPA method 28 and 5G. Not approved for sale after May 15, 2020.

JAN	FEB	MAR	APR	MAY	JUN	JUL	AUG	SEP	OCT	NOV	DEC	
<input type="checkbox"/>	<input type="checkbox"/>	<input type="checkbox"/>	<input type="checkbox"/>	<input type="checkbox"/>	<input type="checkbox"/>	<input type="checkbox"/>	<input type="checkbox"/>	<input type="checkbox"/>	<input type="checkbox"/>	<input type="checkbox"/>	<input type="checkbox"/>	
2015	2016	2017	DO NOT REMOVE THIS LABEL									

7045-179C

Test Lab & Report Number

Mfg Date

**Safety Alert Key:**

- **DANGER!** Indicates a hazardous situation which, if not avoided will result in death or serious injury.
- **WARNING!** Indicates a hazardous situation which, if not avoided may result in death or serious injury.
- **CAUTION!** Indicates a hazardous situation which, if not avoided, may result in minor or moderate injury.
- **NOTICE:** Indicates practices which may cause damage to the appliance or to property.

TABLE OF CONTENTS

A. Congratulations.....	2		
B. Sample of Serial Number/Safety Label.....	2		
C. Warranty	4		
D. Quick Start Guide	6		
1 Listing and Code Approvals			
A. Insert Certification.....	7		
B. BTU & Efficiency Specifications.....	7		
C. Mobile Home Approved	7		
D. Glass Specifications	7		
2 Operating Instructions			
A. Your Wood Appliance.....	8		
B. Fire Safety	9		
C. Overfiring	9		
D. Combustible/Non-combustible Materials	9		
E. Seasoned Wood	9		
F. Burning Process	10		
G. Automatic Combustion Control (ACC).....	11		
H. Air Controls	11		
I. Burn Rates and Operating Efficiency	12		
J. Correct Baffle & Blanket Placement	13		
K. Building A Fire.....	14		
L. Wood Fuel.....	15		
M. Operating the Blower Control Box with Snap Disc.....	16		
N. Blower Operating Instructions	16		
O. Clear Space.....	17		
P. Frequently Asked Questions	17		
Q. Opacity (Smoke).....	17		
		3 Maintenance and Service	
		A. Disposal of Ashes	18
		B. Chimney and Chimney Connector Inspection/Cleaning	18
		C. Appliance Inspection - Routine	18
		D. Cleaning Plated Surfaces	18
		E. Glass Cleaning	19
		F. Inspect Firebrick.....	19
		G. Quick Reference Maintenance Guide	20
		4 Troubleshooting Guide	
		5 Service Parts Replacement	
		A. Glass Replacement - Door Assembly	22
		B. Snap Disc Replacement	22
		C. Blower Replacement	23
		D. Baffle Removal	24
		E. Door Handle Assembly	24
		F. Door Latch Adjustment	24
		G. Tube Channel Assembly Replacement	25
		6 Reference Materials	
		A. Service & Maintenance Log.....	26
		B. Service Parts & Accessories.....	27

C. Warranty

**Hearth & Home Technologies Inc.
LIMITED LIFETIME WARRANTY**

Hearth & Home Technologies Inc., on behalf of its hearth brands ("HHT"), extends the following warranty for HHT gas, wood, pellet, coal and electric hearth appliances that are purchased from an HHT authorized dealer.

WARRANTY COVERAGE:

HHT warrants to the original owner of the HHT appliance at the site of installation, and to any transferee taking ownership of the appliance at the site of installation within two years following the date of original purchase, that the HHT appliance will be free from defects in materials and workmanship at the time of manufacture. After installation, if covered components manufactured by HHT are found to be defective in materials or workmanship during the applicable warranty period, HHT will, at its option, repair or replace the covered components. HHT, at its own discretion, may fully discharge all of its obligations under such warranties by replacing the product itself or refunding the verified purchase price of the product itself. The maximum amount recoverable under this warranty is limited to the purchase price of the product. This warranty is subject to conditions, exclusions and limitations as described below.

WARRANTY PERIOD:

Warranty coverage begins on the date of original purchase. In the case of new home construction, warranty coverage begins on the date of first occupancy of the dwelling or six months after the sale of the product by an independent, authorized HHT dealer/ distributor, whichever occurs earlier. The warranty shall commence no later than 24 months following the date of product shipment from HHT, regardless of the installation or occupancy date. The warranty period for parts and labor for covered components is produced in the following table.

The term "Limited Lifetime" in the table below is defined as: 20 years from the beginning date of warranty coverage for gas appliances, and 10 years from the beginning date of warranty coverage for wood, pellet, and coal appliances. These time periods reflect the minimum expected useful lives of the designated components under normal operating conditions.

Warranty Period		HHT Manufactured Appliances and Venting							Components Covered
Parts	Labor	Gas	Wood	Pellet	EPA Wood	Coal	Electric	Venting	
1 Year		X	X	X	X	X	X	X	All parts and material except as covered by Conditions, Exclusions, and Limitations listed
2 years				X	X	X			Igniters, electronic components, and glass
		X	X	X	X	X			Factory-installed blowers
			X						Molded refractory panels
3 years				X					Firepots and burnpots
5 years	1 year			X	X				Castings and baffles
7 years	3 years		X	X	X				Manifold tubes, HHT chimney and termination
10 years	1 year	X							Burners, logs and refractory
Limited Lifetime	3 years	X	X	X	X	X			Firebox and heat exchanger
90 Days		X	X	X	X	X	X	X	All replacement parts beyond warranty period

See conditions, exclusions, and limitations on next page.

WARRANTY CONDITIONS:

- This warranty only covers HHT appliances that are purchased through an HHT authorized dealer or distributor. A list of HHT authorized dealers is available on the HHT branded websites.
- This warranty is only valid while the HHT appliance remains at the site of original installation.
- Contact your installing dealer for warranty service. If the installing dealer is unable to provide necessary parts, contact the nearest HHT authorized dealer or supplier. Additional service fees may apply if you are seeking warranty service from a dealer other than the dealer from whom you originally purchased the product.
- Check with your dealer in advance for any costs to you when arranging a warranty call. Travel and shipping charges for parts are not covered by this warranty.

WARRANTY EXCLUSIONS:

This warranty does not cover the following:

- Changes in surface finishes as a result of normal use. As a heating appliance, some changes in color of interior and exterior surface finishes may occur. This is not a flaw and is not covered under warranty.
- Damage to printed, plated, or enameled surfaces caused by fingerprints, accidents, misuse, scratches, melted items, or other external sources and residues left on the plated surfaces from the use of abrasive cleaners or polishes.
- Repair or replacement of parts that are subject to normal wear and tear during the warranty period. These parts include: paint, wood, pellet and coal gaskets, firebricks, grates, flame guides, light bulbs, batteries and the discoloration of glass.
- Minor expansion, contraction, or movement of certain parts causing noise. These conditions are normal and complaints related to this noise are not covered by this warranty.
- Damages resulting from: (1) failure to install, operate, or maintain the appliance in accordance with the installation instructions, operating instructions, and listing agent identification label furnished with the appliance; (2) failure to install the appliance in accordance with local building codes; (3) shipping or improper handling; (4) improper operation, abuse, misuse, continued operation with damaged, corroded or failed components, accident, or improperly/incorrectly performed repairs; (5) environmental conditions, inadequate ventilation, negative pressure, or drafting caused by tightly sealed constructions, insufficient make-up air supply, or handling devices such as exhaust fans or forced air furnaces or other such causes; (6) use of fuels other than those specified in the operating instructions; (7) installation or use of components not supplied with the appliance or any other components not expressly authorized and approved by HHT; (8) modification of the appliance not expressly authorized and approved by HHT in writing; and/or (9) interruptions or fluctuations of electrical power supply to the appliance.
- Non-HHT venting components, hearth components or other accessories used in conjunction with the appliance.
- Any part of a pre-existing fireplace system in which an insert or a decorative gas appliance is installed.
- HHT's obligation under this warranty does not extend to the appliance's capability to heat the desired space. Information is provided to assist the consumer and the dealer in selecting the proper appliance for the application. Consideration must be given to appliance location and configuration, environmental conditions, insulation and air tightness of the structure.

This warranty is void if:

- The appliance has been over-fired or operated in atmospheres contaminated by chlorine, fluorine, or other damaging chemicals. Over-firing can be identified by, but not limited to, warped plates or tubes, rust colored cast iron, bubbling, cracking and discoloration of steel or enamel finishes.
- The appliance is subjected to prolonged periods of dampness or condensation.
- There is any damage to the appliance or other components due to water or weather damage which is the result of, but not limited to, improper chimney or venting installation.

LIMITATIONS OF LIABILITY:

- The owner's exclusive remedy and HHT's sole obligation under this warranty, under any other warranty, express or implied, or in contract, tort or otherwise, shall be limited to replacement, repair, or refund, as specified above. In no event will HHT be liable for any incidental or consequential damages caused by defects in the appliance. Some states do not allow exclusions or limitation of incidental or consequential damages, so these limitations may not apply to you. This warranty gives you specific rights; you may also have other rights, which vary from state to state. EXCEPT TO THE EXTENT PROVIDED BY LAW, HHT MAKES NO EXPRESS WARRANTIES OTHER THAN THE WARRANTY SPECIFIED HEREIN. THE DURATION OF ANY IMPLIED WARRANTY IS LIMITED TO DURATION OF THE EXPRESSED WARRANTY SPECIFIED ABOVE.

D. Quick Start Guide

Note: These are generic drawings and may not represent your specific model.

ITEMS NEEDED FOR FIRST FIRE: 10 Pieces of Newspaper, 10-20 Pieces of Dry Kindling and a Few Pieces of Dry Split Wood.

OPEN AIR CONTROLS

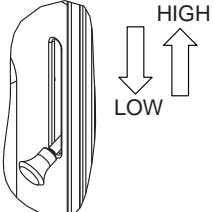

BURN RATE CONTROL
Upper Right Corner

1

LOAD WOOD

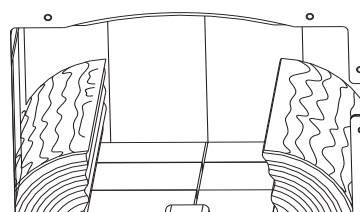

2

ADD NEWSPAPER

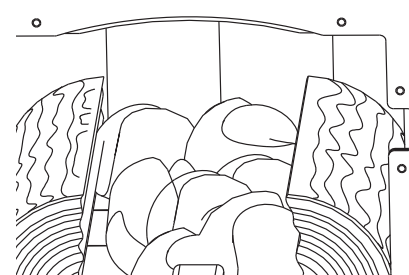

3

ADD KINDLING

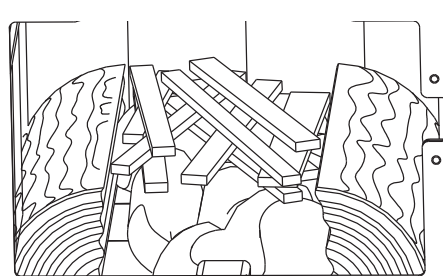

LIGHT THE PAPER

4

WARNING! Risk of Fire

Close and securely latch the door after the fire has started, and after refueling, to prevent:

- Spillage of smoke, flame and carbon monoxide
- Spillage of sparks, coals and logs
- Over-firing

DO NOT leave the stove unattended with the door open.

Starting a fire may not require an open door for draft. The air control should supply adequate draft.

5

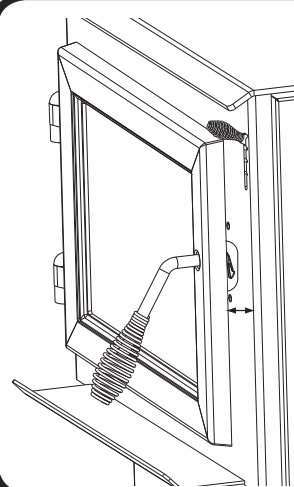

ADD MORE WOOD

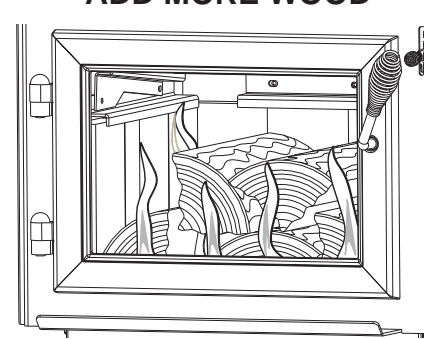

6

REDUCE AIR CONTROL

Set to desired heat output

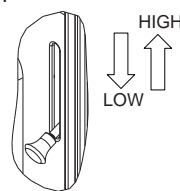

BURN RATE CONTROL
Upper Right Corner

7

The stove is ready for normal operation.

1 Listing and Code Approvals

A. Insert Certification

Model:	4100-I (ACC) Insert
Laboratory:	Intertek
Report No:	100428837PRT-001
Type:	Solid Fuel Type, Listed Room Heater
Standard:	UL1482 and ULC S628-93 and (UM) 84-HUD, Mobile Home Approved.

NOTE: This installation must conform with local codes. In the absence of local codes you must comply with the UL1482, (UM) 84-HUD and NPFA211 in the U.S.A. and the ULC S628-93 and CAN/CSA-B365 Installation Codes in Canada.

B. BTU & Efficiency Specifications

EPA Certification #:	876
EPA Certified Emissions:	4.3 grams per hour
*LHV Tested Efficiency:	78.5 %
**HHV Tested Efficiency:	72.7 %
***EPA BTU Output:	11,700 to 25,900 / hr.
****Peak BTU/Hour Output:	60,500
Vent Size:	6 inches
Firebox Size:	2.43 cubic feet
Maximum Wood Length:	20 inches
Ideal Wood Length:	18 inches
Fuel	Seasoned Cord Wood
* Weighted average LHV efficiency using Douglas Fir dimensional lumber and data collected during EPA emissions test.	
**Weighted average HHV efficiency using Douglas Fir dimensional lumber and data collected during EPA emissions test.	
***A range of BTU outputs based on EPA Default Efficiency and the burn rates from the low and high EPA tests, using Douglas Fir dimensional lumber.	
****A peak BTU out of the unit calculated using the maximum first hour burn rate from the High EPA Test and the BTU content of cordwood (8600) times the efficiency.	

The Quadra-Fire 4100 Wood Insert (ACC) meets the U.S. Environmental Protection Agency's crib wood emission limits for wood heaters sold after May 15, 2015.

This wood heater needs periodic inspection and repair for proper operation. It is against federal regulations to operate this wood heater in a manner inconsistent with operating instructions in this manual.

C. Mobile Home Approved

- This appliance is approved for mobile home installations when not installed in a sleeping room and when an outside combustion air inlet is provided.
- The structural integrity of the mobile home floor, ceiling, and walls must be maintained.
- The appliance must be properly grounded to the frame of the mobile home with #8 copper ground wire, and chimney must be listed to UL103 HT or a listed UL-1777 full length six inch (152mm) diameter liner must be used.
- Outside Air Kit, part OAK-ACC must be installed in a mobile home installation.

D. Glass Specifications

This stove is equipped with 5mm ceramic glass. Replace glass only with 5mm ceramic glass. Please contact your dealer for replacement glass.



WARNING



Fire Risk.

Hearth & Home Technologies disclaims any responsibility for, and the warranty will be voided by, the following actions:

- Installation and use of any damaged appliance.
- Modification of the appliance.
- Installation other than as instructed by Hearth & Home Technologies.
- Installation and/or use of any component part not approved by Hearth & Home Technologies.
- Operating appliance without fully assembling all components.
- Operating appliance without legs attached (if supplied with unit).
- Do NOT Overfire - If appliance or chimney connector glows, you are overfiring.

Any such action that may cause a fire hazard.

Improper installation, adjustment, alteration, service or maintenance can cause injury or property damage.

For assistance or additional information, consult a qualified installer, service agency or your dealer.

NOTE: Hearth & Home Technologies, manufacturer of this appliance, reserves the right to alter its products, their specifications and/or price without notice.

Quadra-Fire is a registered trademark of Hearth & Home Technologies.

User Guide

2 Operating Instructions

⚠ WARNING



HOT SURFACES!

Glass and other surfaces are hot during operation AND cool down.

Hot glass will cause burns.

- **DO NOT** touch glass until it is cooled
- **NEVER** allow children to touch glass
- Keep children away
- **CAREFULLY SUPERVISE** children in same room as appliance.
- Alert children and adults to hazards of high temperatures.

High temperatures may ignite clothing or other flammable materials.

- Keep clothing, furniture, draperies and other flammable materials away.

If you expect that children may come into contact with this appliance, we recommend a barrier such as a decorative screen. See your dealer for suggestions.

A. Your Wood Appliance

WARNING! DO NOT operate appliance before reading and understanding operating instructions.
Failure to operate appliance according to operating instructions could cause fire or injury.

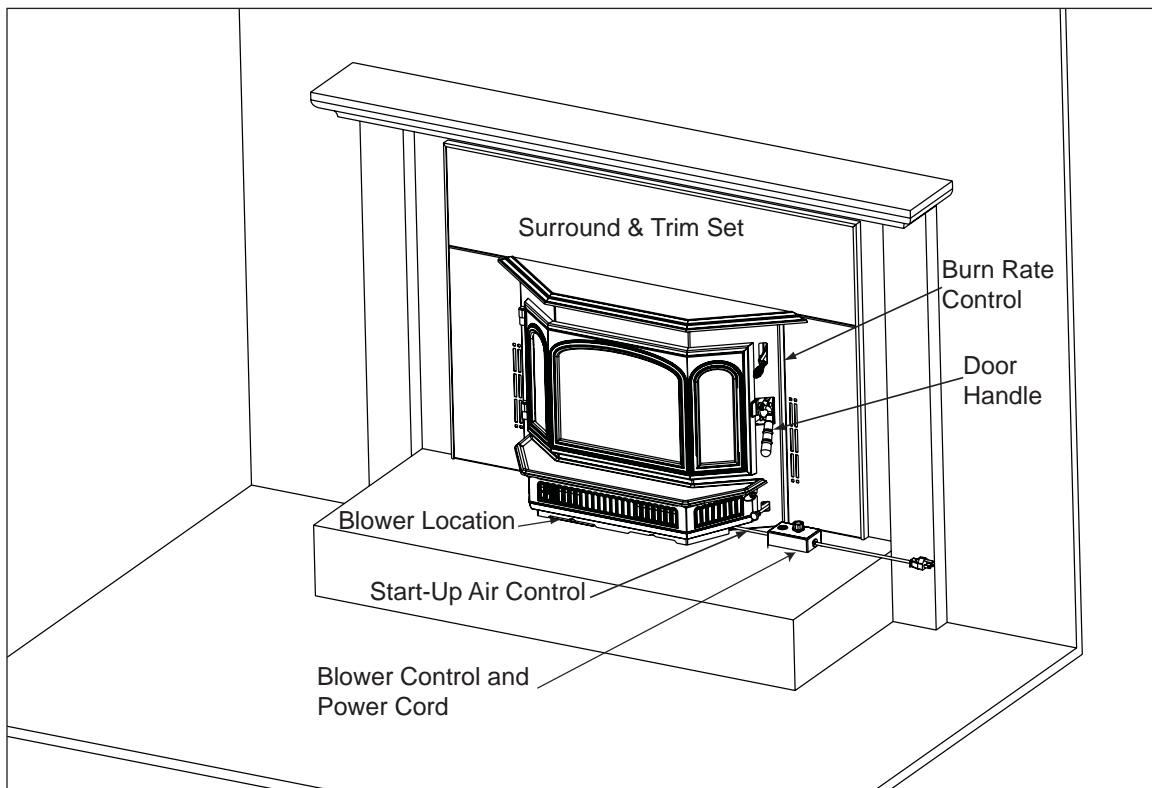

Figure 8.1 - General Operating Parts

B. Fire Safety



To provide reasonable fire safety, the following should be given serious consideration:

1. Install at least one smoke detector on each floor of your home to ensure your safety. They should be located away from the heating appliance and close to the sleeping areas. Follow the smoke detector manufacturer's placement and installation instructions, and be sure to maintain regularly.
2. A conveniently located Class A fire extinguisher to contend with small fires resulting from burning embers.
3. A CO detector should be installed in the room with the appliance.
4. A practiced evacuation plan, consisting of at least two escape routes.
5. A plan to deal with a chimney fire as follows:

In the event of a chimney fire:

- a. Evacuate the house immediately
- b. Notify fire department.

C. Overfiring

 WARNING	
	Fire Risk Do not over-fire. Over-firing may ignite creosote or will damage the stove and chimney. To prevent over-firing your stove, DO NOT:
	<ul style="list-style-type: none"> • Use flammable liquids • Overload with wood • Burn trash or large amounts of scrap lumber • Permit too much air to the fire • Use of processed solid fuel fire logs

1. Symptoms of Over-Firing

Symptoms of over-firing may include one or more of the following:

- Chimney connector or appliance glowing
- Roaring, rumbling noises
- Loud cracking or banging sounds
- Metal warping
- Chimney fire

2. What To Do if Your Stove is Over-Firing

- Immediately close the door and air controls to reduce air supply to the fire.
- If you suspect a chimney fire, call the fire department and evacuate your house.

- Contact your local chimney professional and have your stove and stove pipe inspected for any damage.
- Do not use your stove until the chimney professional informs you it is safe to do so.

Hearth & Home Technologies WILL NOT warranty stoves that exhibit evidence of over-firing. Evidence of over-firing includes, but is not limited to:

- Warped air tube
- Deteriorated refractory brick retainers
- Deteriorated baffle and other interior components

D. Combustible/Non-combustible Materials

• Combustible Material

Material made of or surfaced with wood, compressed paper, plant fibers, plastics, or any material capable of igniting and burning, whether flame-proofed or not, plastered or unplastered.

• Non-combustible Material

Material which will not ignite and burn. Such materials are those consisting entirely of steel, iron, brick, tile, slate, glass or plasters, or any combination thereof.

• Non-combustible Sealant Material

Sealants which will not ignite and burn: Rutland, Inc. Fireplace Mortar #63, Rutland 76R, Nuflex 304, GE RTV106 or GE RTB116 (or equivalent).

E. Seasoned Wood

Burn only dry seasoned wood.

- Store wood under cover, out of the rain and snow.
- Dry and well-seasoned wood will not only minimize the chance of creosote formation, but will give you the most efficient fire.
- Even dry wood contains at least 15% moisture by weight, and should be burned hot enough to keep the chimney hot for as long as it takes to dry the wood out - about one hour.
- It is a waste of energy to burn unseasoned wood of any kind.

Dead wood lying on the forest floor should be considered wet, and requires full seasoning time.

- Standing dead wood can be considered to be about 2/3 seasoned.
- To tell if wood is dry enough to burn, check the ends of the logs.
- If there are cracks radiating in all directions from the center, it is dry.
- If your wood sizzles in the fire, even though the surface is dry, it may not be fully cured.

F. Burning Process

In recent years there has been an increasing concern about air quality. Much of the blame for poor air quality has been placed on the burning of wood for home heating.

In order to improve the situation, we at Quadra-Fire have developed cleaner-burning wood appliances that surpass the requirements for emissions established by our governing agencies.

These wood appliances must be properly operated in order to ensure that they perform the way they are designed to perform.

NOTICE: Improper operation can turn any wood appliance into a smoldering environmental hazard.

1. Kindling or First Stage

It helps to know a little about the actual process of burning in order to understand what goes on inside the appliance. The first stage of burning is called the kindling stage.

In this stage:

- Wood is heated to a temperature high enough to evaporate the moisture present in all wood.
- Wood will reach the boiling point of water (212°F) and will not get any hotter until the water is evaporated.

This process takes heat from the coals and tends to cool the appliance.

Fire requires three things to burn:

- Fuel
- Air
- Heat

If heat is robbed from the appliance during the drying stage, the new load of wood has reduced the chances for a good clean burn.

It is always best to burn dry, seasoned firewood. When the wood isn't dry, you must open the air controls and burn at a high burn setting for a longer time to start it burning.

The heat generated from the fire should be warming your home and establishing the flue draft, not evaporating the moisture out of wet, unseasoned wood, resulting in wasted heat.

2. Second Stage

In the secondary stage wood gives off flammable gases which burn above the fuel with bright flames.

During this stage of burning:

- The flames must be maintained and not allowed to go out to ensure the cleanest possible fire.
- If the flames tend to go out, it is set too low for your burning conditions.

The air control located at the upper right hand corner is used to adjust for burn rates. This is called the Burn Rate Air Control. **Figure 11.1 on page 11.**

3. Final Stage

The final stage of burning is the charcoal stage. This occurs when the flammable gases have been mostly burned and only charcoal remains. This is a naturally clean portion of the burn. The coals burn with hot blue flames.

- It is very important to reload your appliance while enough lively hot coals remain in order to provide the amount of heat needed to dry and rekindle the next load of wood.
- It is best to open the Burn Rate Air and Start-Up Air Controls **before reloading**. This livens up the coal bed and reduces excessive emissions (opacity/smoke).
- Open door slowly so that ash or smoke does not exit appliance through opening.
- Break up any large chunks and distribute the coals so that the new wood is laid on hot coals.

Air quality is important to all of us, and if we choose to use wood to heat our homes we should do so responsibly.

We need to learn to burn in the cleanest way possible allowing us to continue using our wood appliances for many years to come.

G. Automatic Combustion Control (ACC)

Typically, when you build a fire, you open the air controls fully and monitor the fire to prevent it from going into an overfire situation and/or burning your wood up too quickly before you shut down the air controls to the desired burn rate.

When using the Automatic Combustion Control (ACC) system, you do not have to continually monitor the fire. Once you set the ACC system it will control the fire for you. Follow the instructions below to learn how to operate your stove with ease.

H. Air Controls

1. Start-Up Air Control

The Start-Up Air Control has two primary functions.

The first function is to activate the Automatic Combustion Control system (ACC).

- Push the Start-Up Air Control all the way back until it stops and then pull forward to the front of the appliance until it stops. **Figure 11.1.**
- The front air channel opens and allows air to enter the front of the appliance for approximately 20-25 minutes.
- The front air channel gradually shuts down until it is completely closed at the end of the 20-25 minutes.
- The fire is now controlled by the air supplied by the Burn Rate Air Control. **Figure 11.1.**
- This function should be performed each time you reload the appliance.

The second function of the Start-Up Air Control is operation of the rear air system.

- Push the Start-Up Air Control 3/8 inch (9.5mm) back to allow rear air to enter the firebox. **Figure 11.1.**
- The rear air is used primarily during a High Burn Rate.
- In some instances rear air is desired during normal operation to help with combustion of fuel towards the back of the firebox particularly when burning hardwoods.
- The rear air is controlled independently from the ACC system.

2. Manual Timer Over-Ride

If you need to shut the ACC system off before it shuts itself off after 25 minutes (i.e. overfire situation), lift up on the Start-up Air Control (1) and pull out from the appliance (2). **Figure 11.2.**

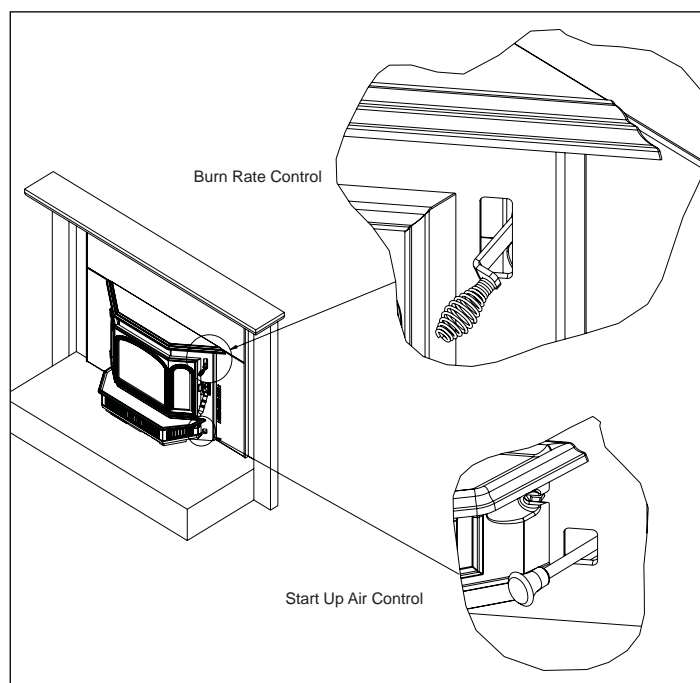

Figure 11.1 Start-up and Burn Rate Air Controls

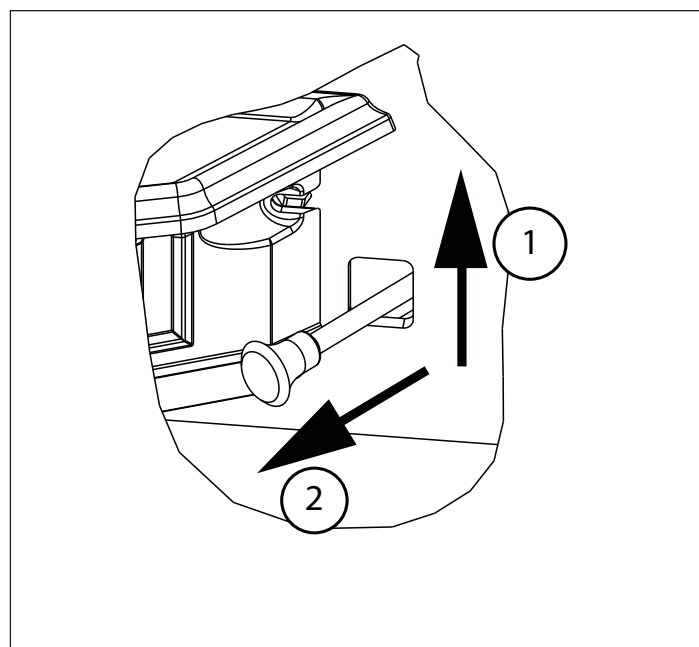

Figure 11.2 Manual Timer Over-Ride

3. Burn Rate Air Control

- The air supply enters at the upper front of the firebox, near the top of the glass door.
- This preheated air supplies the necessary fresh oxygen to mix with the unburned gases, helping to create the second, third and fourth combustion process.
- This air is regulated by the Burn Rate Air Control.
- There are four settings High, Medium-High, Medium-Low and Low.
- When the control is raised all the way up it is on the High setting and when pushed all the way down it is on the Low setting. **Figure 12.1.**

I. Burn Rates and Operating Efficiency

This wood heater has a manufacturer-set minimum low burn rate that must not be altered. It is against federal regulations to alter this setting or otherwise operate this wood heater in a manner inconsistent with operating instructions in this manual.

For maximum operating efficiency

1. Burn dry, well-seasoned wood.
2. Follow these burn rate instructions below and refer to **Figure 12.1**

***NOTE:** These are guidelines. Actual settings may vary with type of wood, chimney draft, altitude and other variables.

Burn Rates

1. Starting a Fire and Reloading

- Open both controls fully by raising the Burn Rate Air Control all the way up until it stops and push the Start-up Air Control back until it stops.
- The blower tends to cool the appliance. Leave the blower off until the burn is well established, i.e., 30 minutes.
- After loading the appliance with wood and starting the fire, set both controls to the desired setting by following the burn rate instructions below.

2. High Burn Rate - Maximum Heat*

- Raise the Burn Rate Air Control all the way up until it stops (top marker) to a fully open position.
- Push the Start-Up Air Control all the way back until it stops and leave it there.
- This setting over-rides the timer system (ACC) so you must monitor the fire closely while in this setting.

3. Medium-High Burn Rate - 15,000 to 30,000 BTU/hr*

- Raise the Burn Rate Air Control all the way up until it stops (top marker) to a fully open position.
- Push the Start-Up Air Control all the way back until it stops and then pull forward until it stops.
- This activates the timer system (ACC).

4. Medium-Low Burn Rate - 10,000 to 15,000 BTU/hr*

- Raise the Burn Rate Air Control up to the bottom of the middle marker and stop.
- Push the Start-Up Air Control all the way back until it stops and then pull forward until it stops.
- This activates the timer system (ACC).

5. Low Burn Rate - Below 10,000 BTU/hr*

- Leave the Burn Rate Air Control at the bottom marker.
- Push the Start-Up Air Control all the way back until it stops and then pull forward until it stops.
- This activates the timer system (ACC).

***NOTE:** These are approximate settings, and will vary with type of wood or chimney draft. Due to altitude and other environmental circumstances, this operational information is a guideline only.

WARNING



Risk of Fire or Chimney Fire.

Avoid Overfire

DO NOT over-ride the Automatic Combustion Control when the burn rate is set to HIGH

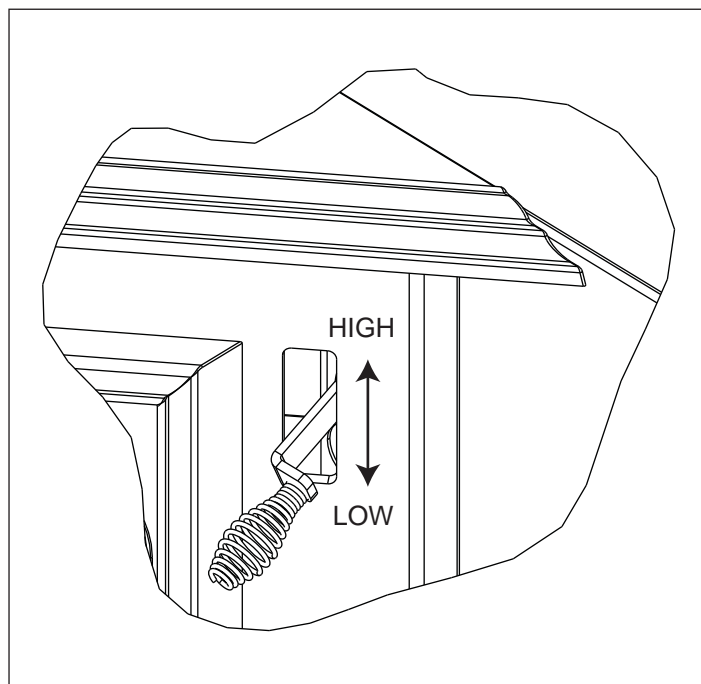



Figure 12.1 Air Control

After activating the timer (ACC), if the control is placed within 3/8 inch (9.5mm) inward from the full OUT position it will allow rear air to enter the firebox. This will not interfere with the timer gradually closing the front air channel in 20-25 minutes. If control is set full inward on "HI" it over-rides the timer (ACC).

J. Correct Baffle & Blanket Placement



WARNING

Fire Risk
Improper baffle placement may cause:

- Overheating of firebox
- Overheating the chimney

Baffle must be placed properly (see instructions)
Replace baffle if damaged or missing.

NOTE: A missing, damaged or improperly positioned baffle is dangerous and may cause damage and poor efficiency. It will also void your warranty.

Note: This are generic drawings and may not represent your specific model.

CORRECT POSITION

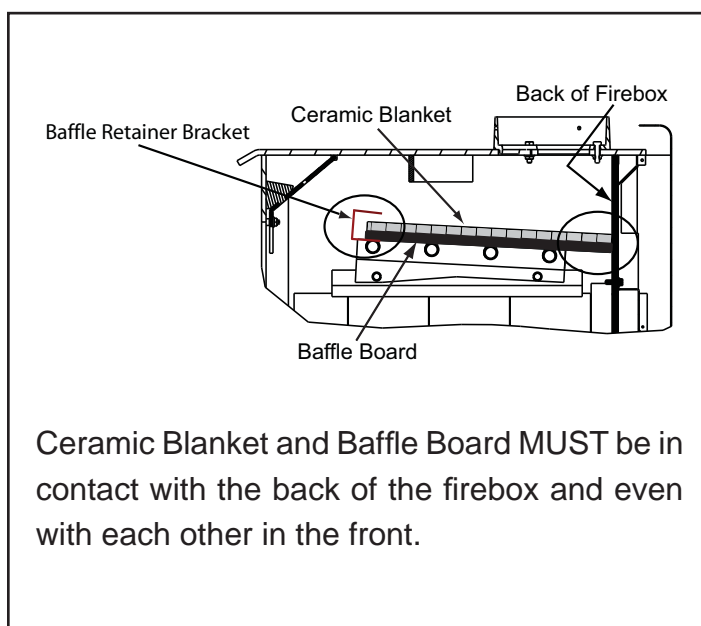

Figure 13.1 - Correct Baffle and Blanket Positions

INCORRECT POSITIONS

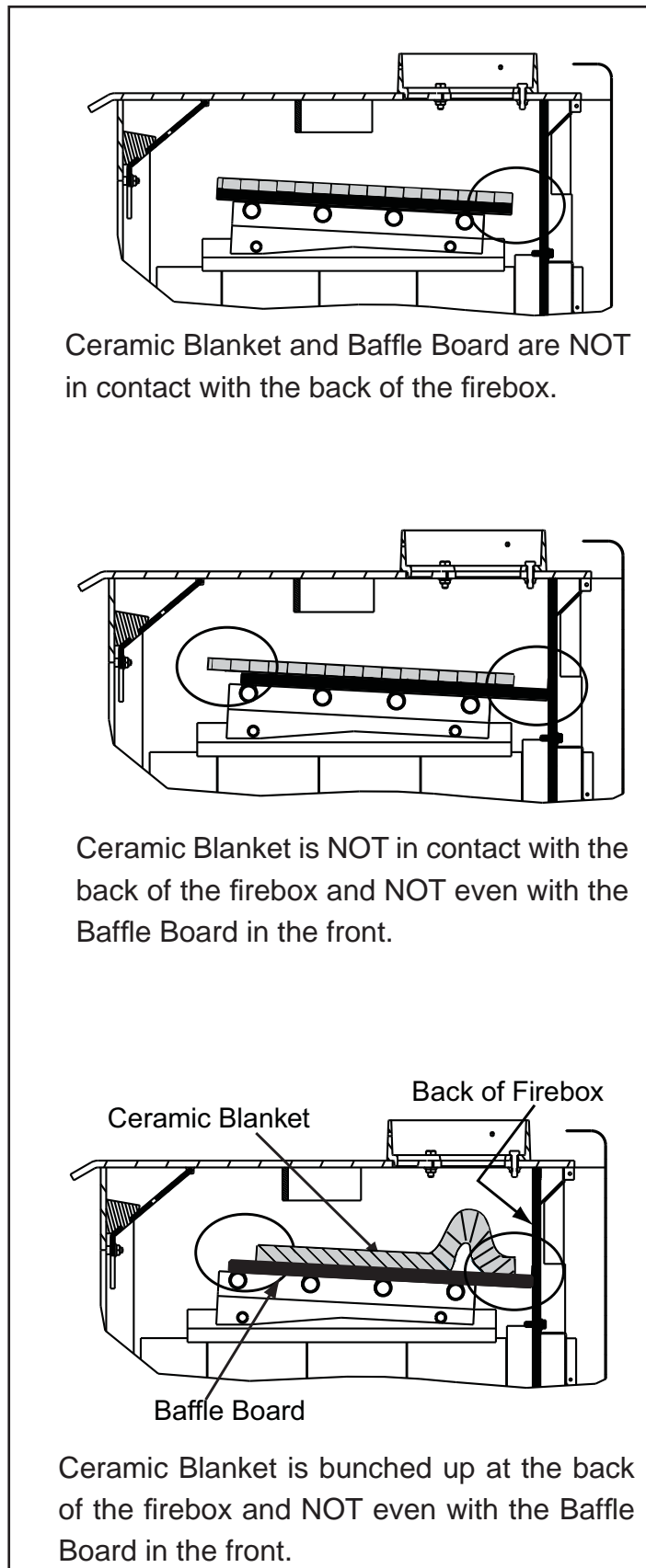



Figure 13.2 - Incorrect Baffle and Blanket Positions

K. Building A Fire

 WARNING	
	<p>Fire Risk. Keep combustible materials, gasoline and other flammable vapors and liquids clear of appliance.</p> <ul style="list-style-type: none"> • Do NOT store flammable materials in the appliance's vicinity. • DO NOT USE GASOLINE, LANTERN FUEL, KEROSENE, CHARCOAL LIGHTER FLUID OR SIMILAR LIQUIDS TO START OR "FRESHEN UP" A FIRE IN THIS HEATER. • Keep all such liquids well away from the heater while it is in use. • Combustible materials may ignite.

10. When ready to reload, it is best to fully open both the Burn Rate Air and Start-up Air Controls **before reloading**.
 - This livens up the coal bed and reduces excessive emissions (opacity/smoke).
 - Open door slowly so that ash or smoke does not exit appliance through opening.
 - Large logs burn slowly, holding a fire longer.
 - Small logs burn fast and hot, giving quick heat.
11. As long as there are hot coals, repeating steps 6 through 8 will maintain a continuous fire.

NOTE:

- Build fire on brick firebox floor.
- Do NOT use grates, andirons or other methods to support fuel. It will adversely affect emissions.

Before lighting your first fire in the appliance:

1. Confirm the baffle and ceramic blanket are correctly positioned. They should be even with the front tube and resting on all tubes. **See page 13.**
2. Remove all labels from glass.

There are many ways to build a fire. The basic principle is to light easily-ignitable tinder or paper, which ignites the fast burning kindling, which in turn ignites the slow-burning firewood. Here is one method that works well:

1. Open firebox door (to open rotate handle counter clockwise).
2. Open the Burn Rate Air and Start-Up Air Controls fully.
3. Place several wads of crushed paper on the firebox floor. Heating the flue with slightly crumpled newspaper before adding kindling keeps smoke to a minimum.
4. Lay small dry sticks of kindling on top of the paper.
5. Make sure that no matches or other combustibles are in the immediate area of the appliance. Be sure the room is ventilated and the flue unobstructed.
6. Light the paper in the appliance. NEVER light or rekindle fire with kerosene, gasoline, or charcoal lighter fluid; the results can be fatal.
7. Once the kindling is burning quickly, add several full-length logs 3 to 4 inches (76 - 102mm) in diameter. Be careful not to smother the fire. Stack the pieces of wood 1/2 to 1 inch apart (13-25mm); near enough to keep each other hot, but far enough away from each other to allow air flow between them.
8. Close door and latch securely (rotate handle clockwise).
9. Set the Burn Rate Air Control and activate the timer system (ACC).

CAUTION

Odors and vapors released during initial operation.

- Curing of high temperature paint.
- Open windows for air circulation.

Odors may be irritating to sensitive individuals.

CAUTION

Do not leave door open during normal operation (except for re-fuel).

CAUTION

To prevent damages, do not stack burnables against glass.

L. Wood Fuel

WARNING





Fire Risk.

- DO NOT BURN GARBAGE OR FLAMMABLE FLUIDS SUCH AS GASOLINE, NAPHTHA OR ENGINE OIL.

- DO NOT USE CHEMICALS OR FLUIDS TO START A FIRE.
- Do NOT burn treated wood or wood with salt (driftwood).
- May generate carbon monoxide if burn material other than wood.

May result in illness or possible death.

WARNING



Fire Risk.

- Do NOT burn wet or green wood.
- Store wood in dry location.
- Stack wood so both ends are exposed to air.

Wet, unseasoned wood can cause accumulation of creosote.

Moisture

The majority of the problems appliance owners experience are caused by trying to burn wet, unseasoned wood.

- Wet, unseasoned wood requires energy to evaporate the water instead of heating your home, and
- Causes evaporating moisture which cools your chimney, accelerating formation of creosote.

Seasoned Wood

- Cut logs to size
- Split to 6 inches (152 mm) or less in diameter
- Air dry to a moisture content of not more than 20%
 - Soft wood - about nine months to dry
 - Hard wood - about eighteen months to dry

NOTICE: Seasoning time may vary depending on drying conditions.

Storing Wood

Steps to ensure properly seasoned wood:

- Stack wood to allow air to circulate freely around and through woodpile.
- Elevate wood pile off ground to allow air circulation underneath.
- Smaller pieces of wood dry faster. Any piece over 6 in. (152 mm) in diameter should be split.
- Wood (whole or split) should be stacked so both ends of each piece are exposed to air. More drying occurs through the cut ends than the sides.
- Store wood under cover to prevent water absorption from rain or snow. Avoid covering the sides and ends completely.

Hardwood vs Softwood

Your appliance performance depends on the quality of the firewood you use.

- Seasoned wood contains about 8,000 BTUs per pound .
- Hard woods are more dense than soft woods.
- Hard woods contain 60% more BTUs than soft woods.
- Hard woods require more time to season, burn slower and are harder to ignite.
- Soft woods require less time to dry, burn faster and are easier to ignite.
- Start the fire with softwood to bring the appliance up to operating temperature and to establish draft.
- Add hardwood for slow, even heat and longer burn time.

Soft woods

- Douglas Fir
- Pine
- Spruce
- Cedar

Hard woods

- Oak
- Maple
- Apple
- Birch
- Poplar
- Aspen
- Alder

Processed Solid Fuel Fire Logs

- NOT permitted for use in this appliance

WARNING



Fire Risk

Do NOT store wood:

- In front of the appliance.
- In space required for loading or ash removal.

M. Operating the Blower Control Box with Snap Disc

1. The blower will turn on/off automatically when set to AUTO. **Figure 16.1.**
2. When set to MANUAL, the fan will turn on/off only when you turn it on or off. This setting over-rides the internal snap disc.
3. Adjust the speed of the fan by turning the HIGH/LOW knob to the desired setting.

N. Blower Operating Instructions

1. **Initial (cold) startup:** Open both controls fully by raising the Burn Rate Air Control all the way up until it stops and push the Start-up Air Control back until it stops. The blower tends to cool the appliance. Leave the blower off until the burn is well established, i.e., 30 minutes.
2. **High Burn Setting:** Both controls are open. Burn Rate Air Control is pulled up and the Start-up Air Control is fully pushed in. Blower may remain on.
3. **Medium High Burn Setting*:** Burn Rate Air Control is closed then opened to 1 inch (pull up)to fully open. Blower may remain on.
4. **Medium Low Burn Setting*:** Burn Rate Air Control is closed then opened to 1/4 inch to 1/2 inch. Leave the blower off until the burn is well established, i.e., 30 minutes.
5. **Low Burn Setting*:** Burn Rate Air Control is closed. Leave the blower off until the burn is well established, i.e., 30 minutes.

***NOTE:** For burn settings 3 to 5 the Start-up Air Control needs to be pushed in (Open) then pulled forward to activate the Automatic Combustion Control (ACC).

NOTE: For maximum efficiency and lowest emissions, when operating the blower in either the automatic or manual setting for the low and medium low burn settings leave the blower off until the burn is well established, i.e., 30 minutes.

6. The blower is equipped with a rheostat (speed control). The highest blower speed is obtained by turning the rheostat on, then adjusting back towards "OFF" as far as possible without turning the blower off. For a low blower speed, turn the control knob clockwise as far as possible

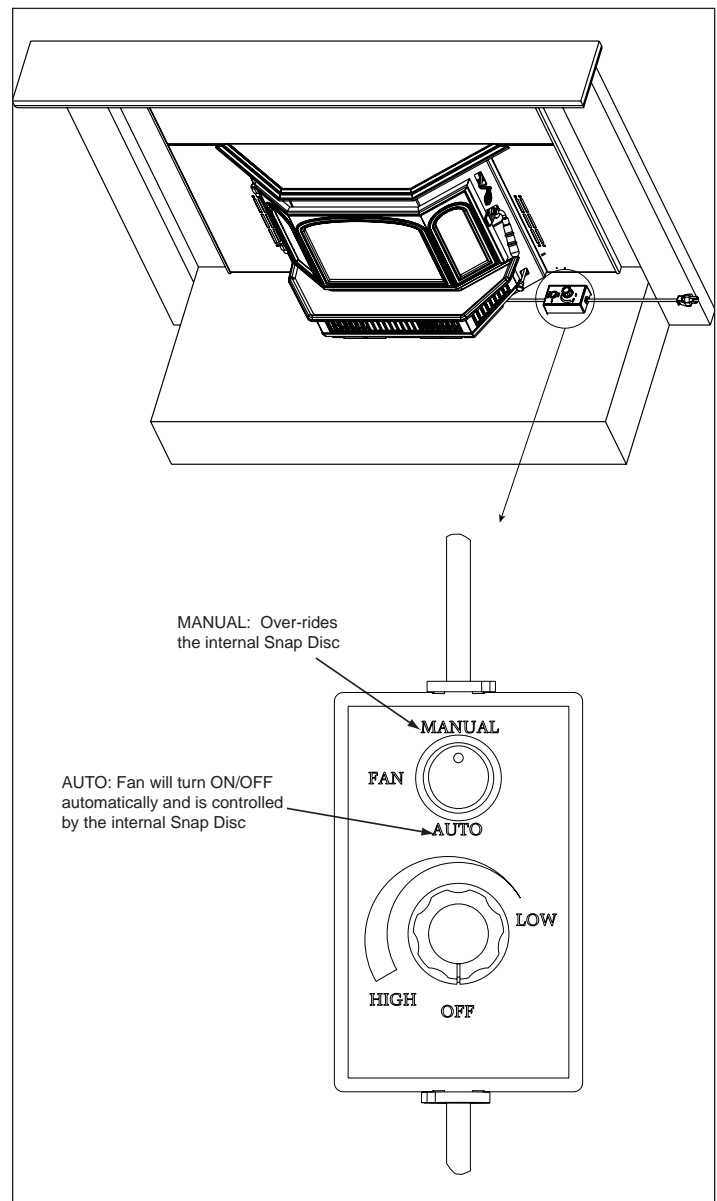

Figure 16.1

O. Clear Space

- Do NOT place combustible objects within 4 ft (1.2 m) of the front of appliance. **Figure 17.1.**

WARNING

Fire Risk.

- Do NOT place combustible objects within 48 inches in front of the appliance.
- High temperatures may ignite clothing, furniture or draperies.

Q. Opacity (Smoke)

Opacity is the measure of how cleanly your appliance is burning.

Opacity is measured in percent:

- 100% opacity is when an object is totally obscured by the smoke column from a chimney, and
- 0% opacity means that no smoke column can be seen.

As you become familiar with your appliance, you should periodically check the opacity. This will allow you to know how to burn as nearly smoke-free as possible (goal of 0% opacity).

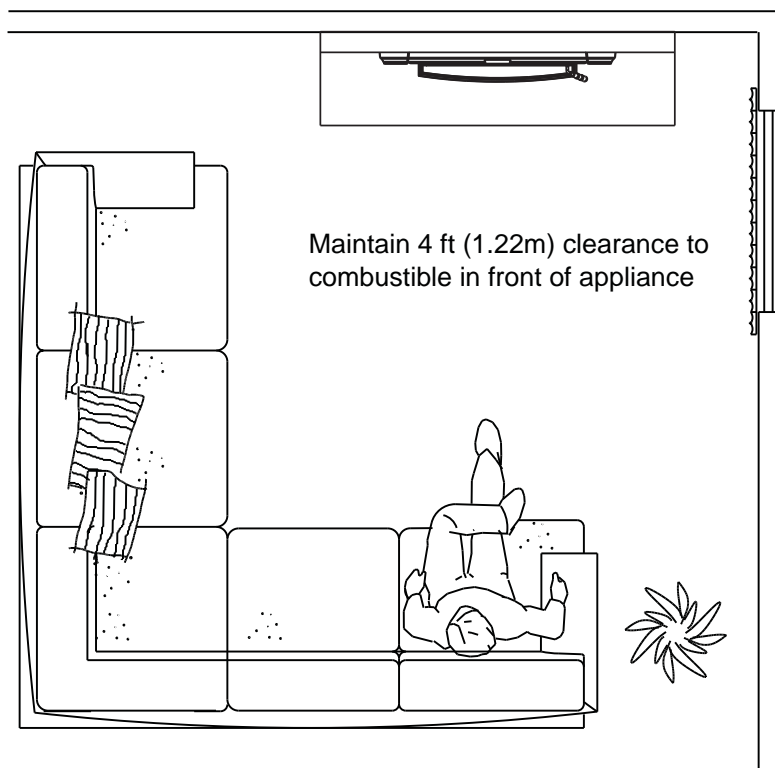

NOTICE!

Do NOT operate a circulating fan within close proximity, approximately 4 ft (1.2m), of appliance

- Can reverse air flow, blowing hot air into appliance cavity.
- Can damage appliance blower due to overheating.

Figure 17.1 - Clear Space

P. Frequently Asked Questions

ISSUES	SOLUTIONS
Odor from appliance	When first operated, this appliance may release an odor for the first several hours. This is caused by the curing of the paint and the burning off of any oils remaining from manufacturing.
Metallic noise	Noise is caused by metal expanding and contracting as it heats up and cools down, similar to the sound produced by a furnace or heating duct. This noise does not affect the operation or longevity of the appliance.
Whirring sound	The blower may produce a whirring sound which increases in volume as the speed is increased.

Contact your dealer for additional information regarding operation and troubleshooting.
Visit www.quadrafire.com to find a dealer.

3 Maintenance and Service

When properly maintained, your fireplace will give you many years of trouble-free service. **Contact your dealer** to answer questions regarding proper operation, troubleshooting and service for your appliance. Visit www.quadrafire.com to find a dealer. We recommend annual service by a qualified service technician.

A. Disposal of Ashes

- **Frequency:** When ash is within 1-3/4 inch (44mm) of firebox lip. Leave 1/4 to 1/2 inch (6-13mm) of ash in the bottom of the firebox.
- **By:** Homeowner

WARNING! Risk of Fire! Ashes could contain hot embers.

- Place ashes in a metal container with a tight-fitting lid.
- The closed container should be placed on a noncombustible floor or on the ground, well away from all combustible materials, pending final disposal.
- If the ashes are disposed of by burial in soil or otherwise locally dispersed, they should be retained in the closed container until all cinders have thoroughly cooled

B. Chimney and Chimney Connector Inspection/Cleaning

- **Frequency:** Every 2 months during heating season or as recommended by a certified chimney sweep; more frequently if chimney exceeds or is under 14-16 feet (4.3 to 4.8m) measured from bottom of appliance.
- **By:** Certified chimney sweep
- Remove all ash from the firebox and extinguish all hot embers before disposal.
- Allow the appliance to cool completely.
- If your type of installation involves a full reline of the chimney, it will be necessary to either remove the baffle from the insert, or remove the insert from the fireplace and disconnect the vent prior to cleaning the chimney. Refer to **page 24** in this manual for instructions on Baffle Removal.
- If your type of installation is direct connect within a masonry chimney, the insert will need to be pulled out from the fireplace and disconnected from the flue prior to cleaning the chimney.
- The creosote or soot should be removed with a brush specifically designed for the type of chimney in use.
- Clean out fallen ashes from the firebox.
- It is also recommended that before each heating season the entire system be professionally inspected, cleaned and repaired if necessary.

WARNING! Risk of Fire!

Do not use chimney cleaners or flame colorants in your appliance. It will corrode your pipe.

Creosote - Formation and Need for Removal

- When wood is burned slowly, it produces tar and other organic vapors, which combine with expelled moisture to form creosote.
- The creosote vapors condense in the relatively cool chimney flue of a slow-burning fire.
- As a result, creosote residue accumulates on the flue lining. When ignited this creosote makes an extremely hot fire.
- The chimney and chimney connector shall be inspected every two months during the heating season to determine when a creosote buildup has occurred.
- When creosote has accumulated it shall be removed to reduce the risk of a chimney fire.

C. Appliance Inspection - Routine

- **Frequency:** Every 2 months at the same time the chimney and chimney connector are inspected.
- **By:** Homeowner

Check for:

- Cracks in glass
- Door handle - smooth cam operation
- Baffle and ceramic blanket correct placement
- Baffle for warpage
- Firebrick for cracks, broken or crumbly
- Door gasket. (Dollar bill test). Place a dollar bill between the stove and the door and then shut the door. If you can pull the dollar bill out, replace the door gasket.
- Glass frame for loose screws

D. Cleaning Plated Surfaces

- **Frequency:** As desired
- **By:** Homeowner
- Clean all the fingerprints and oils from plated surfaces **BEFORE** firing the appliance for the first time.
- If not cleaned properly before lighting your first fire, the oils can cause permanent markings on the plating.
- After the plating is cured, the oils will not affect the finish and little maintenance is required.
- Wipe clean as needed.

CAUTION! Do not use polishes with abrasives. It will scratch plated surfaces.

E. Glass Cleaning

- **Frequency:** As desired
- **By:** Homeowner
- Clean glass with a non-abrasive glass cleaner. Abrasive cleaners may scratch and cause glass to crack.
- If the deposits on the glass are not very heavy, normal glass cleaners work well. Heavier deposits may be removed by using a damp cloth dipped in wood ashes or by using a commercially available oven cleaner.
- After using an oven cleaner, it is advisable to remove any residue with a glass cleaner or soap and water. Oven cleaner left on during the next firing can permanently stain the glass and damage the finish on plated metal surfaces.
- A portion of the combustion air entering the firebox is deflected down over the inside of the door glass.
- This air flow “washes” the glass, helping to keep smoke from adhering to its surface.
- When operated at a low burn rate, less air will be flowing over the glass and the smoky, relatively cool condition of a low fire will cause the glass to become coated.
- Operating the appliance with the Burn Rate Air Control and Start-Up Air Control all the way open for 15-20 minutes should remove the built up coating.

CAUTION! Handle glass assembly with care. Glass is breakable.

- *Avoid striking, scratching or slamming glass*
- *Avoid abrasive cleaners*
- *Do not clean glass while it is hot*

F. Inspect Firebrick

- **Frequency:** After each ash removal
- **By:** Homeowner

Replace the firebrick if they become crumbly and/or if there is a 1/4 inch (6.35mm) gap between the bricks.

The firebox is lined with firebrick, which has exceptional insulating properties. Do not use a grate; simply build a fire on the firebox floor. Do not operate appliance without firebrick.

1. After the coals have completely cooled, remove all old brick and ash from unit and vacuum firebox.
2. Remove new brick set from box and lay out to the diagram shown in the instructions that come with the brick set or refer to the diagram on the service parts list at the end of this manual.
3. Lay bottom bricks in unit.
4. Install rear bricks on the top of the bottom bricks. Slide top of bricks under clip on back of firebox wall and push bottom of bricks back.
5. Install side bricks. Slide top of brick under clips on side of firebox and push the bottom of the brick until it is flush with the side of the unit.

G. Quick Reference Maintenance Guide

CAUTION! Allow the appliance to completely cool down before performing any cleaning or maintenance.

Start the first inspection after the first 2 months of use, or if performance changes, and adjust your schedule accordingly. Maintenance is required for safe operation and must be performed to maintain your warranty.

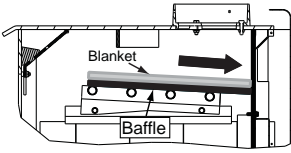
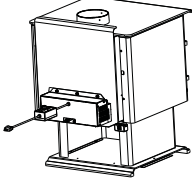
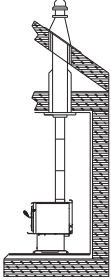
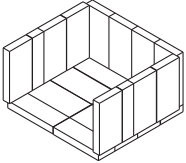
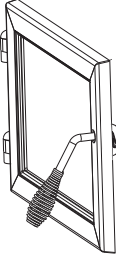
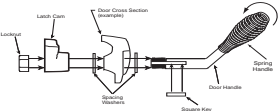
	Frequency	Task
<p>Baffle & Blanket</p> 	<p>MONTHLY, After Every Cord of Wood, OR After Each Cleaning</p>	<p>Baffle and blanket placement is critical to heat output, efficiency and overall life of the unit. Make sure the baffle is pushed all of the way to the back of the firebox and the blanket is laying flat. Inspect baffle for cracks.</p>
<p>Optional Blower</p> 	<p>YEARLY</p>	<p>Vacuum the blower impellers.</p>
<p>Chimney System</p> 	<p>EVERY 2 MONTHS or After Every 2 Cords of Wood</p>	<p>The chimney and chimney cap must be inspected for soot and creosote every two months during the burn season or more frequency if chimney exceeds or is under 14-16 ft (4.3m-4.8m) measured from bottom of appliance.</p> <p>This will prevent pipe blockage, poor draft, and chimney fires.</p> <p>Always burn dry wood to help prevent cap blockage and creosote build-up.</p>
<p>Firebrick & Ash Removal</p> 	<p>WEEKLY or After Every 25 Loads of Wood</p>	<p>Ashes must be cool before you can dispose of the ashes in a non-combustible container.</p> <p>Firebrick is designed to protect your firebox. After ashes are removed, inspect the firebrick and replace firebricks that are crumbling, cracked or broken.</p>
<p>Door & Glass Assemblies</p> 	<p>WEEKLY or After Every 25 Loads of Wood</p>	<p>Keep door and glass gasket in good shape to maintain good burn times on a low burn setting. To test: place a dollar bill between the stove and door and then shut the door. If you can pull the dollar out, remove one washer from door handle behind latch cam and try again. If you can still pull it out, replace the door gasket.</p> <p>Check the glass frame for loose screws to prevent air leakage. Check glass for cracks.</p>
<p>Door Handle</p> 	<p>YEARLY</p>	<p>Check the door latch for proper adjustment. This is very important especially after the door rope has formed to the stove face.</p> <p>Check door handle for smooth cam operation.</p>

These are generic drawings and may not represent your model.

4 Troubleshooting Guide

With proper installation, operation, and maintenance your wood stove will provide years of trouble-free service. If you do experience a problem, this troubleshooting guide will assist you or a qualified service person in the diagnosis of a problem and the corrective action to be taken.

Start Fire Problems	Possible Cause	Solution
Can not get fire started Excessive smoke or spillage Burns too slowly Not enough heat output	Not enough kindling/paper or no kindling/paper	Use dry kindling, more paper. Arrange kindling & wood for air movement.
	Not enough air for fire to ignite	Check for restricted termination cap
		Check for blockage of outside air kit (if installed).
		Check for flue blockage.
		Pre-warm flue before starting fire (refer to Building a Fire Section).
		Check for adequate vent height (refer to Chimney Height Section).
	Open window below the appliance towards the wind.	
	Wood condition is too wet, too large	Use dry, seasoned wood (refer to Seasoned Wood Section).
	Bed of coals not established before adding wood	Start with paper & kindling to establish bed of coals (refer to Building a Fire Section).
Flue blockage such as birds' nests or leaves in termination cap	Have chimney inspected for creosote and cleaned by a certified chimney sweep.	
Down draft or negative pressure Competition with exhaust devices	Do not use exhaust fans during start-up (refer to Negative Pressure Section).	
	Open window below the appliance towards the wind.	
Fire burns too fast	Extremely dry or soft wood	Mix in hardwood.
		Mix in less seasoned wood after fire is established (refer to Wood Fuel Section).
	Overdrafting	Check for correct vent height; too much vertical height creates overdrafting.
		Check location of vent termination (refer to Chimney Termination Requirement Section).

5 Service Parts Replacement

A. Glass Replacement - Door Assembly (Replace with 5mm ceramic glass only)

1. Ensure that the fire is out and the appliance is cool to the touch.
2. Protect a table or counter top with padding or towels. Protect your hands and wear gloves to prevent injury.
3. Remove the door with the broken glass by lifting the door up and off of the hinges.
4. Lay door face down on a table or counter making sure the handle hangs over the edge so the door lays flat, on a soft surface.
5. Remove the screws from each glass retainer and remove the glass. (If screws are difficult to remove, soak with penetrating oil first).
6. Center the glass with edges evenly overlapping the opening in the door, (i.e. same space top and bottom, left and right sides).
7. Replace the glass retainers. Be careful not to cross thread the screws.
8. Tighten each retainer just a few turns until each is secured. Check again for centering of glass in door frame. Continue to tighten each retainer alternately, a few turns at a time, until the glass is secure. **DO NOT OVER TIGHTEN** - can cause glass to break.
9. Replace the door on the appliance.

Quadra-Fire appliances are equipped with ceramic super heat-resistant glass, which can only be broken by impact or misuse.



WARNING! Risk of Fire or Injury!

Use only glass that is specified in the manual, DO NOT replace with any other material. Glass breakage will occur.

CAUTION!

Handle glass with care.

- Inspect the gasket to ensure it is undamaged.
- Do NOT strike, slam or scratch glass.
- Do NOT operate appliance with glass & door assembly removed.
- Do NOT operate with glass cracked, broken or scratched.

	CAUTION
	<p>Shock Risk.</p> <ul style="list-style-type: none"> • Do NOT remove grounding prong from plug. • Plug directly into properly grounded 3 prong receptacle. • Route cord away from appliance. • Do NOT route cord under or in front of appliance.

B. Snap Disc Replacement

1. The snap disc bracket assembly is located on top of the blower assembly towards the side. **Figure 22.1.**
2. Remove the 2 allen head bolts using a 5/32 Allen wrench from the blower housing and pull the housing towards you.
3. Using a Phillips head screw driver, remove the 2 screws from the Blower Assembly as shown and slide assembly out.
4. Using a Phillips head screw driver, remove the 2 screws from the snap disc and then remove the snap disc from the spade connectors. Replace with new snap disc and re-connect to spade connectors.
5. Re- install in reverse order

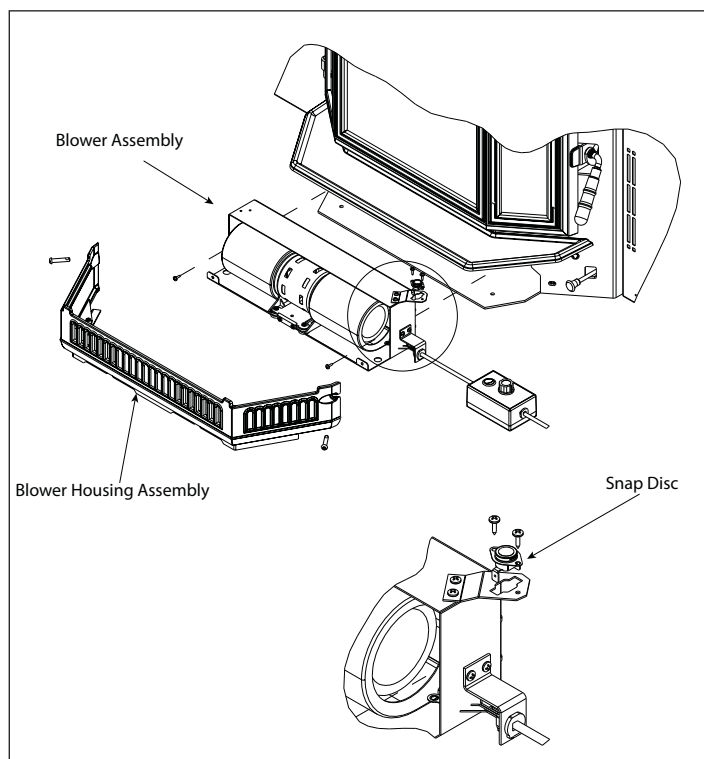

Figure 22.1

C. Blower Replacement

1. Remove the 2 screws from the Blower Housing Assembly using a 5/32 allen wrench. **Figure 23.1.**
2. Disconnect the wires from the blower.
3. Remove the 2 screws from the hold down bracket and pull the blower and bracket forward.
4. Remove the blower from the hold down bracket.
5. Re-install in reverse order. Be certain that the hold down bracket's screws are completely seated in the grommets. Insert the locating tab in the hold down bracket into the placement slot.

⚠ CAUTION



Shock Risk.

- Do NOT remove grounding prong from plug.
- Plug directly into properly grounded 3 prong receptacle.
- Route cord away from appliance.
- Do NOT route cord under or in front of appliance.

⚠ WARNING



Fire Risk.

- Do NOT allow hot coals or embers to overflow ash lip
- May melt protective wire coating on fan power cord causing electrical short, fire or injury

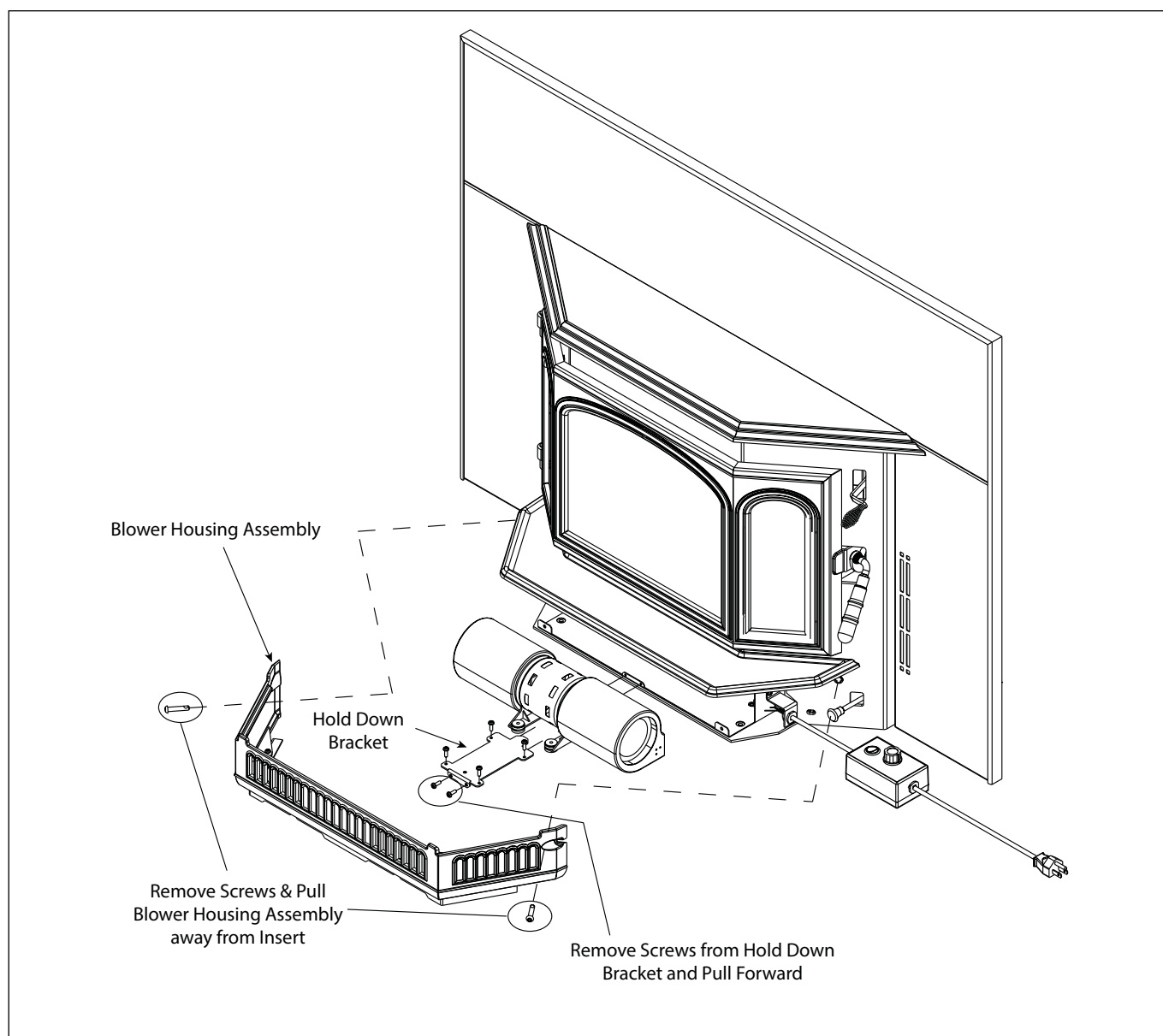

Figure 23.1

D. Baffle Removal

1. Remove all ash from the firebox, and extinguish all hot embers before disposal into a metal container.
2. The baffle board has 2 pieces. With the ceramic blanket still in place, slide one baffle piece over the top of other one but still keep it all components inside the firebox. **Figure 24.1.**
3. It is easier to remove both baffle boards and ceramic blanket after the tube channel assembly has been partially disassembled. Follow steps 1 through 4 on **page 25** for removal of the tube channel assembly. It is not necessary to completely remove the tube channel assembly.
4. Re-install in reverse order. Be sure the baffle boards and ceramic blanket are in their proper positions. **Figure 24.2.**

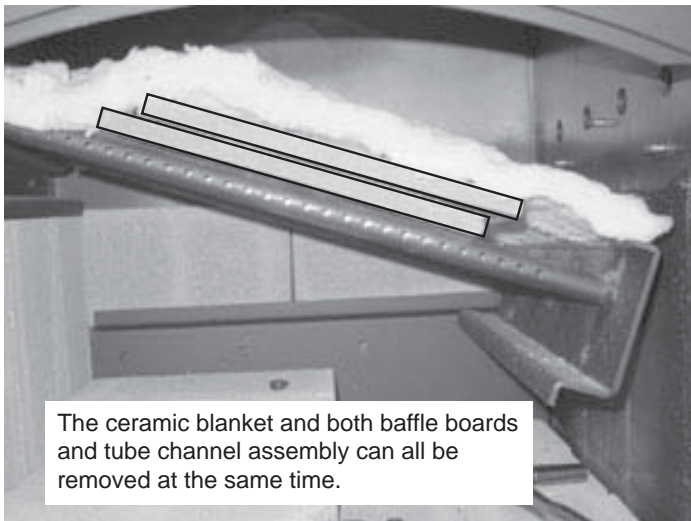

Figure 24.1

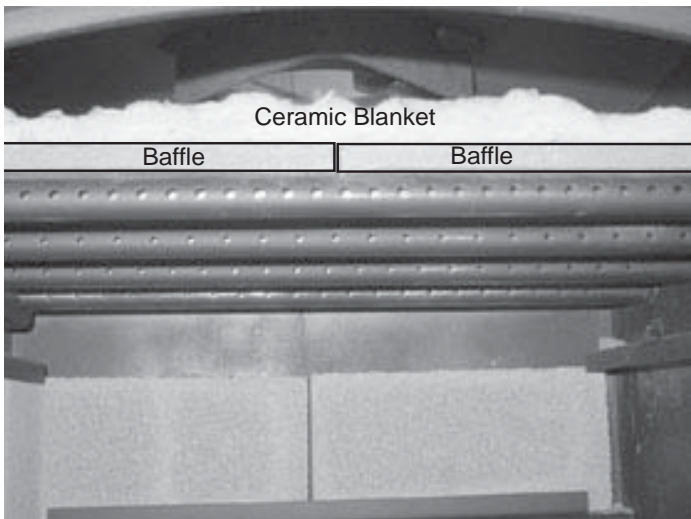

Figure 24.2

E. Door Handle Assembly

CAUTION! Do not over tighten lock nut. The door handle needs to move smoothly.

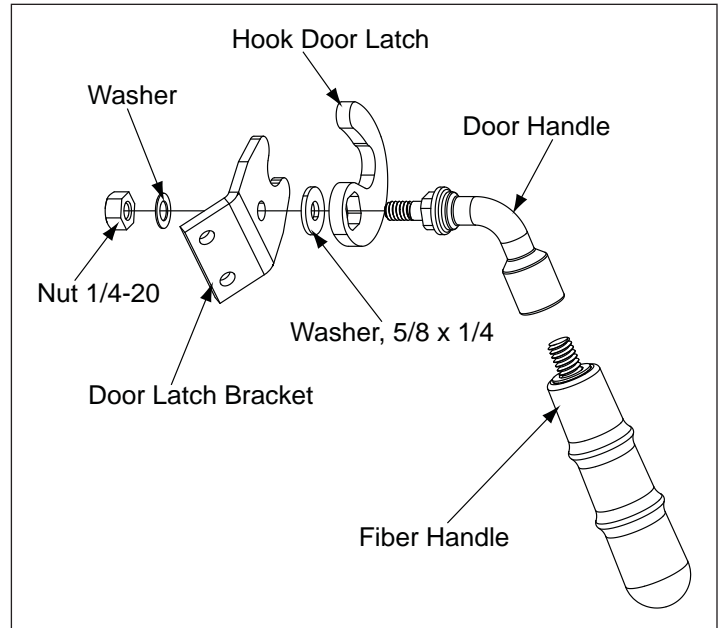
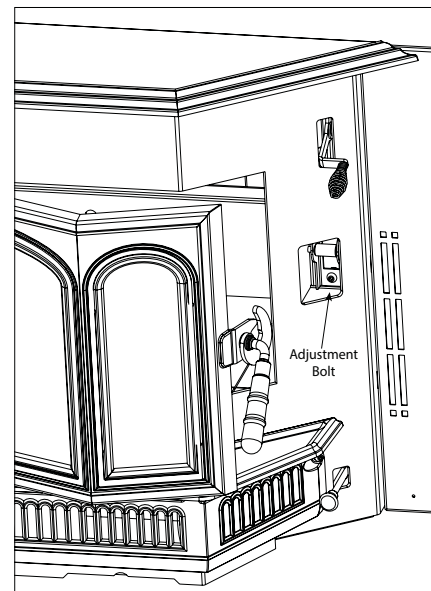

Figure 24.3 - Door Handle for Arched Door

F. Door Latch Adjustment

It is important the door gasket has a proper seal. As the gasket compresses or “seats” during use, it may become necessary to adjust or tighten the door latch.

1. Open door to access adjustment bolt.
2. Using a 5/32 allen tool, turn the adjustment bolt clockwise slightly.
3. Close door to test adjustment. If more is needed, repeat the previous process.



G. Tube Channel Assembly Replacement

Removing Tube Channel Assembly

1. Remove the right side bricks (3 pieces).
2. Remove the baffle protection channel by rolling forward and out of the firebox.
3. Locate the 2 channel nuts and 2 channel bolts inside of chamber and remove.

NOTE: Soak the bolts with penetrating oil for at least 15 minutes before trying to remove them.

4. Slide the tube channel assembly all the way to left until it

is off the threads. Drop the right side down, then slide the assembly back to right.

5. The ceramic blanket and both baffle boards can be removed at the same time you remove the tube channel assembly.
6. When the tube channel assembly is free of the left side support, rotate clockwise and pull assembly, blanket and baffles out through the front opening.
7. Re-install in reverse order.

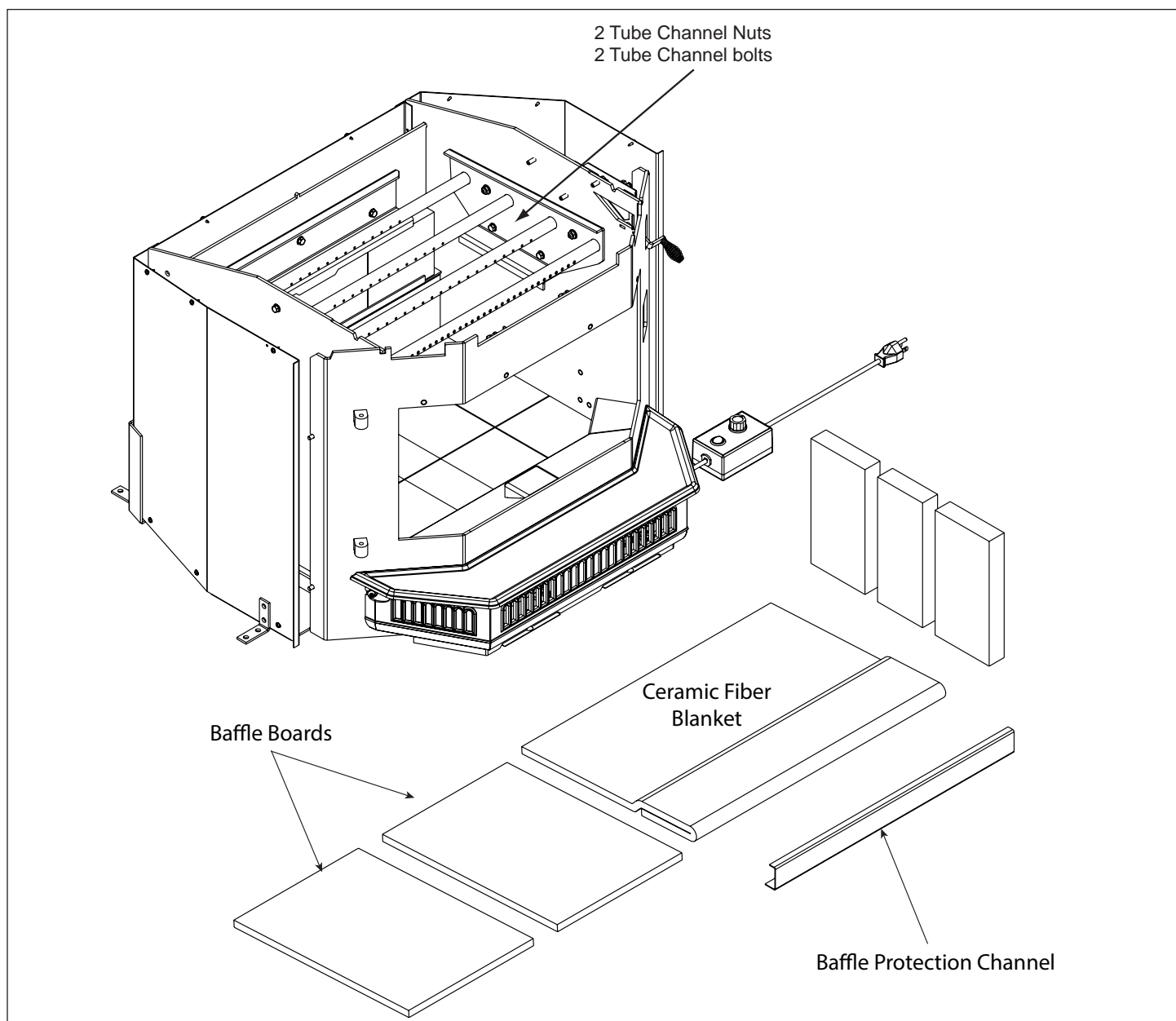

Figure 25.1

B. Service Parts & Accessories

QUADRA-FIRE® Service Parts

41I-ACC-BK

Wood Insert

Beginning Manufacturing Date: Sept 2011
Ending Manufacturing Date: Active

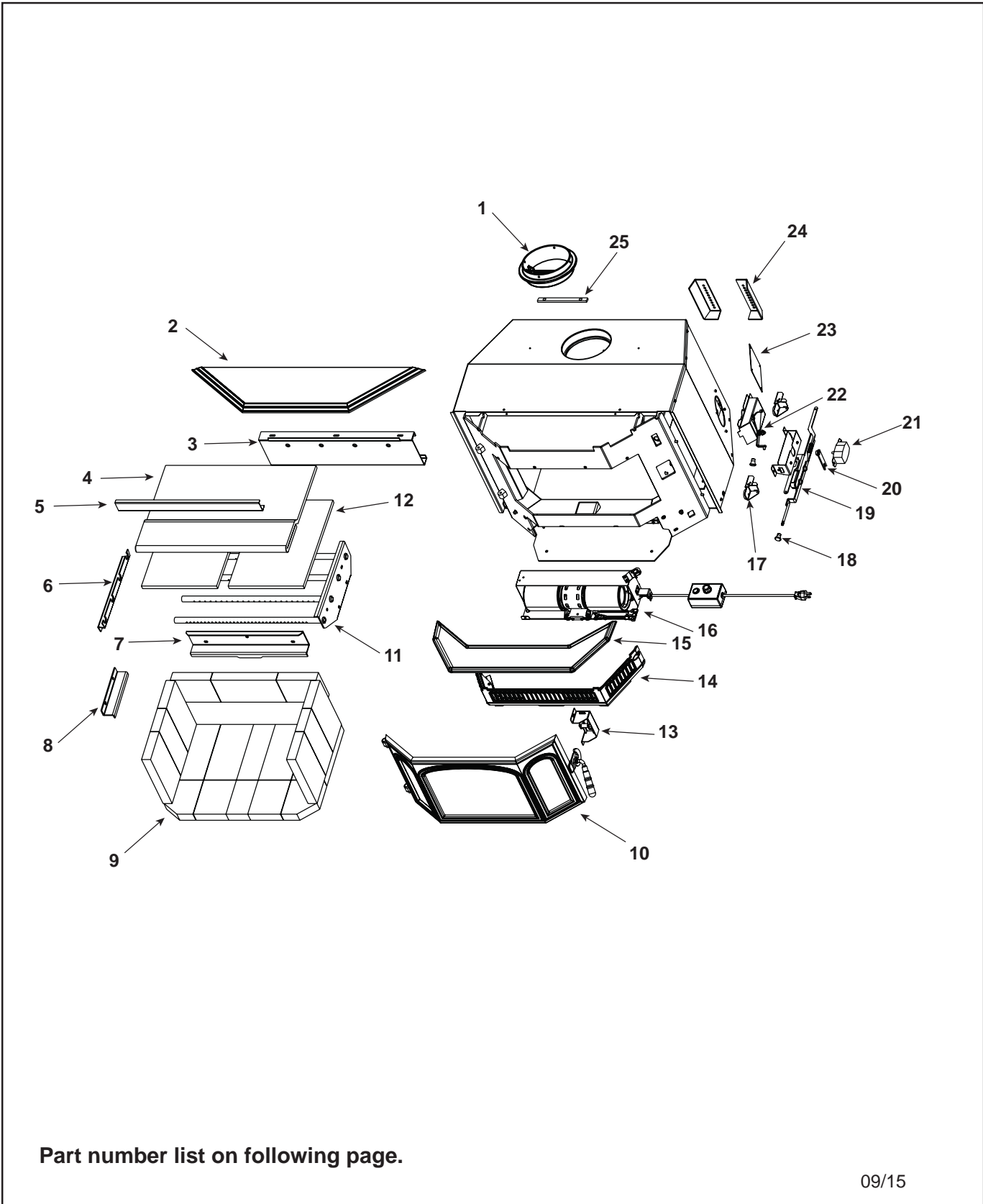

Part number list on following page.

09/15

Beginning Manufacturing Date: Sept 2011
Ending Manufacturing Date: Active

IMPORTANT: THIS IS DATED INFORMATION. Parts must be ordered from a dealer or distributor. **Hearth and Home Technologies does not sell directly to consumers.** Provide model number and serial number when requesting service parts from your dealer or distributor.



Stocked at Depot

ITEM	DESCRIPTION	COMMENTS	PART NUMBER	
1	Flue Attach Ring		SRV7044-154	
2	Outer Top		435-0300	
3	Rear Channel Assembly		SRV7045-001	Y
	Screw Hwh Ms 1/4-20 X 34 Ns		220-0080/25	
4	Ceramic Fiber Blanket		832-3401	Y

#5 Baffle Protection Channel

Side view

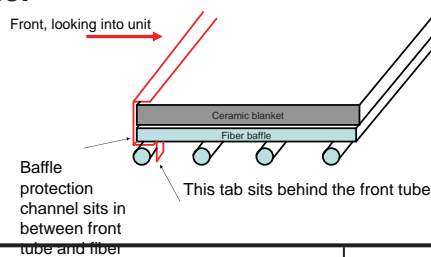

5	Baffle Protection Channel		SRV7045-183	Y
6	Tube Support Rack		SRV7045-154	
7	Rear Brick Retainer		SRV7045-119	
8	Brick Retainer Side		SRV7045-186	

#9 Brick Set

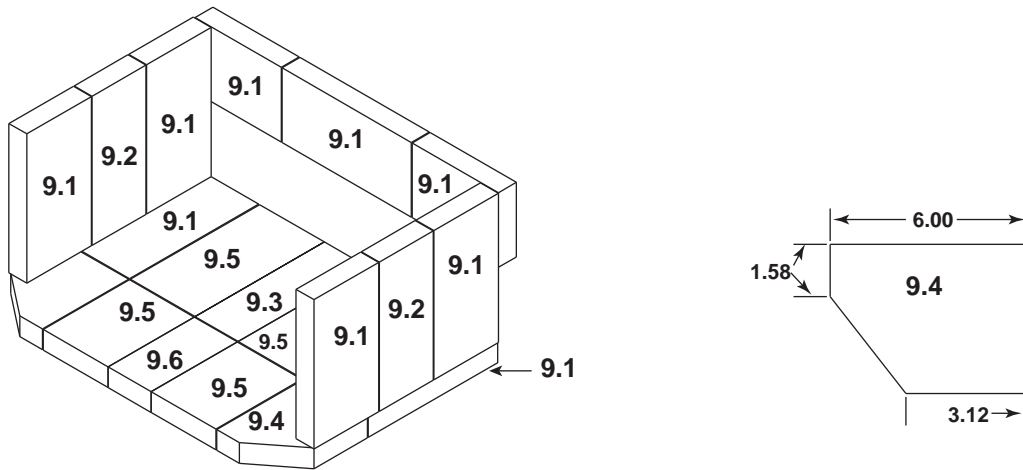

9	Brick Set, Complete Assembly	Pkg of 20	SRV7045-014	
9.1	Brick 1, (9 x 435 x1.25)	Qty 9 req		
9.2	Brick 2,(9 x 3.75 x 1.25)	Qty 2 req		
9.3	Brick 3, (9 x 2.5 x 1.25)	Qty 1 req		
9.4	Brick 4, (6 x 4.5 x 1.25) w/angle	Qty 2 req		
9.5	Brick 5, (6 x 4.5 x 1.25")	Qty 4 req		
9.6	Brick 6, (6 x 2.5 x 1.25")	Qty 1 req		
	Brick, Uncut (9 x 4.5 x 1.25")	Qty: 12 Req.	832-0550	
	Brick, Uncut (9 x 4.5 x 1.25")	Pkg. of 6	832-3040	

Additional service part numbers appear on following page.

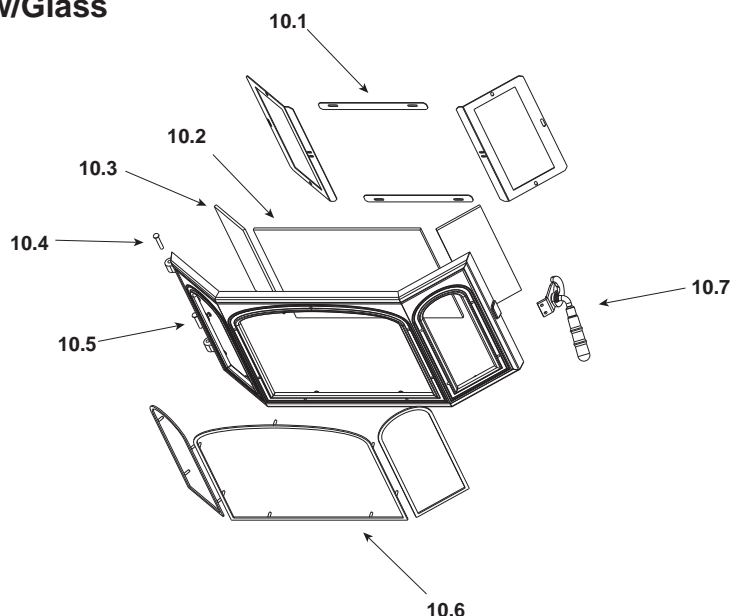
#10 Door Assembly w/Glass

IMPORTANT: THIS IS DATED INFORMATION. Parts must be ordered from a dealer or distributor. **Hearth and Home Technologies does not sell directly to consumers.** Provide model number and serial number when requesting service parts from your dealer or distributor.

**Stocked
at Depot**

ITEM	DESCRIPTION	COMMENTS	PART NUMBER	
10	Door Assembly w/Glass		SRV7045-018	
10.1	Glass Frames	4 pieces	435-0960	
	Screw, Pan Head Philips 8-32 X 3/8		225-0500/40	Y
10.2	Glass Assembly Front		435-5470	Y
10.3	Glass Assembly Side		435-5480	Y
10.4	Hinge Pin	Pkg of 2	433-1590/2	
10.5	Door, Cast		435-0050	
10.6	Door Trim Black		SRV7045-170	
	Nut, Keps Lock, 8-32		226-0060/40	Y
10.7	Door Handle Assembly		SRV7045-007	
	Screw, Pan Head Philips, 10/32 X 1/4		229-1230/24	Y
	Rope, Door, .625 Low Dens	8 Ft	842-1420	
11	Tube Channel Assembly		SRV7045-006	
	Nut, Ser Flange Small 1/4-20		226-0130/24	
	Screw Hwh Ms 1/4-20 X 34 Ns		220-0080/25	
12	Baffle Board	2 pieces	SRV7045-160	
13	Door Latch Bracket Assembly		SRV7045-021	
14	Blower Housing Assembly		SRV7045-015	
	Screw, Bh, 1/4-20 X 1.25		225-0630/24	
15	Ashcatcher, Cast		435-0310	

IMPORTANT: THIS IS DATED INFORMATION. Parts must be ordered from a dealer or distributor. **Hearth and Home Technologies does not sell directly to consumers.** Provide model number and serial number when requesting service parts from your dealer or distributor.



**Stocked
at Depot**

ITEM	DESCRIPTION	COMMENTS	PART NUMBER	
<p>#16 Blower Assembly</p>				
16	Blower Assembly		SRV7045-013	
16.1	Blower Control Box W/Switch		SRV7000-194	
16.2	Strain Relief		7000-463/20	
16.3	Snap Disc, # 1, Convection Blower		SRV230-0470	
16.4	Blower Replacement		SRV7044-210	
16.5	Wire Harness		SRV7045-177	
17	Timer Door Assembly		SRV7044-020	
18	Knob	Pkg of 2	32284/2	Y
19	Air Control Assembly		SRV7045-009	
20	Timer Control Arm Assembly		SRV7045-028	
21	Timer (Only) Replacement Assembly		SRV480-1940	
22	Burn Rate Control Assembly		SRV7045-005	
	Screw Hwh Ms 1/4-20 X 34 Ns		220-0080/25	
23	Outside Air Cover Plate		SRV7044-217	
24	Leveling Legs	2 pieces (Left and Right)	SRV7045-184	
25	Chimney Ring Attach		SRV7044-181	
	Door Trim Kit (Includes Door Trim, Spring Handle, Hinge Pins, And Logo)	No Longer Available	41IDRTRIM-GD	
		Nickel	41IDRTRIM-NL	
	Surround, 43 X 31 (Order Trim Kit Separately)		SP-41IACC-STD	
	Surround Trim Kit 43 X 31	Black	TRIMKIT-4331-BK	
		No Longer Available	TRIMKIT-4331-GD	
		Nickel	TRIMKIT-4331-NL	
	Surround, 51 X 34 (Order Trim Kit Separately)		SP-41IACC-LRG	
	Surround Trim Kit 51 X 34	Black	TRIMKIT-5134-BK	
		No Longer Available	TRIMKIT-5134-GD	
		Nickel	TRIMKIT-5134-NL	
	Surround, Standard (Order Cast Trim Kit Separately)		SP-41I-CM-STD	
	Surround, Large (Order Cast Trim Kit Separately)		SP-41I-CM-LRG	
	Cast Trim Kit, Black		811-0930	
	Outside Air Kit		OAK-ACC	
	Adjustable Hearth Support 12 X 50, 2-10" H		ADJSPT-12	

QUADRA-FIRE®

NOTHING BURNS LIKE A QUAD

CONTACT INFORMATION

Hearth & Home Technologies
1445 North Highway
Colville, WA 99114
Division of HNI INDUSTRIES

Please contact your Quadra-Fire dealer with any questions or concerns.
For the number of your nearest Quadra-Fire dealer
log onto www.quadrafire.com

CAUTION



DO NOT DISCARD THIS MANUAL

- Important operating and maintenance instructions included.
- Read, understand and follow these instructions for safe installation and operation.
- Leave this manual with party responsible for use and operation.

DO NOT
DISCARD

We recommend that you record the following pertinent information for your heating appliance.

Date purchased/installed: _____

Serial Number: _____ Location on appliance: _____

Dealership purchased from: _____ Dealer phone: _____

Notes: _____

This product may be covered by one or more of the following patents: (United States) 5341794, 5263471, 6688302, 7216645, 7047962 or other U.S. and foreign patents pending.