

# Owner's Manual

## Operation & Care

**INSTALLER:** Leave this manual with party responsible for use and operation.

**OWNER:** Retain this manual for future reference.

Contact your dealer with questions on installation, operation, or service.

**NOTICE: DO NOT DISCARD THIS MANUAL**

# QUADRA-FIRE®

## SANTA FE PELLET INSERT STOVE

**Model(s):  
SANTAFEI-MBK**

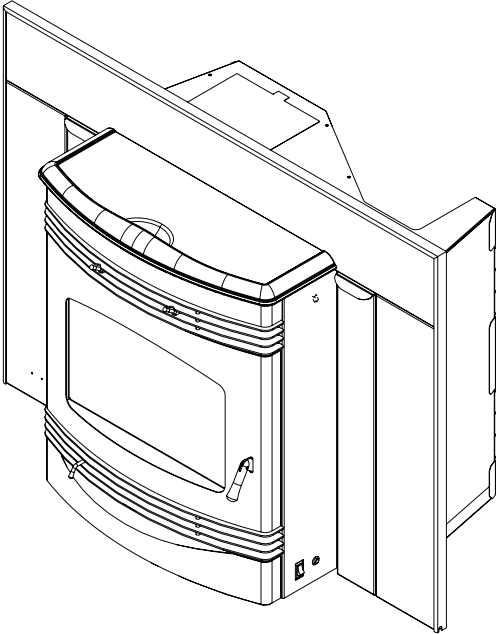

 Pellet Fuels Institute

Tested and Listed by  Portland Oregon USA  
OMNI-Test Laboratories, Inc.

### CAUTION

Tested and approved for wood pellets and corn pellets. Burning of any other type of fuel voids your warranty.

### CAUTION

Check building codes prior to installation.

- Installation **MUST** comply with local, regional, state and national codes and regulations.
- Consult local building, fire officials or authorities having jurisdiction about restrictions, installation inspection, and permits.

### WARNING



If the information in these instructions is not followed exactly, a fire could result causing property damage, personal injury, or death.

- Do not store or use gasoline or other flammable vapors and liquids in the vicinity of this or any other appliance.
- Do not overfire - If heater or chimney connector glows, you are overfiring. Overfiring will void your warranty.
- Comply with all minimum clearances to combustibles as specified. Failure to comply may cause house fire.

### WARNING



#### **HOT SURFACES!**

Glass and other surfaces are hot during operation AND cool down.

**Hot glass will cause burns.**

- Do not touch glass until it is cooled
- **NEVER** allow children to touch glass
- Keep children away
- **CAREFULLY SUPERVISE** children in same room as fireplace.
- Alert children and adults to hazards of high temperatures
- **High temperatures may ignite clothing or other flammable materials.**
- Keep clothing, furniture, draperies and other flammable materials away.

### NOTE

To obtain a French translation of this manual, please contact your dealer or visit [www.quadrafire.com](http://www.quadrafire.com)

Pour obtenir une traduction française de ce manuel, s'il vous plaît contacter votre revendeur ou visitez [www.quadrafire.com](http://www.quadrafire.com)

# Congratulations

and Welcome to the Quadra-Fire Family!

## A. Congratulations

Hearth & Home Technologies welcomes you to our tradition of excellence! In choosing a Quadra-Fire appliance, you have our assurance of commitment to quality, durability, and performance.

This commitment begins with our research of the market, including 'Voice of the Customer' contacts, ensuring we make products that will satisfy your needs. Our Research and Development facility then employs the world's most advanced technology to achieve the optimum opera-

tion of our stoves, inserts and fireplaces. And yet we are old-fashioned when it comes to craftsmanship. Each unit is meticulously fabricated and gold and nickel surfaces are hand-finished for lasting beauty and enjoyment. Our pledge to quality is completed as each model undergoes a quality control inspection.

We wish you and your family many years of enjoyment in the warmth and comfort of your hearth appliance. Thank you for choosing Quadra-Fire.

**NOTE: Clearances may only be reduced by means approved by the regulatory authority having jurisdiction**

## B. Sample of Serial Number / Safety Label

LOCATION: On chain behind right access panel & Behind left access panel

**QUADRA-FIRE**  
SANTA FE PELLET INSERT

SERIAL NO. / NUMÉRO DE SÉRIE

007015

2015 2016 2017

JAN FEB MAR APR MAY JUNE

JULY AUG SEPT OCT NOV DEC

Tested & Listed By Portland Oregon USA  
OMNI-Test Laboratories, Inc.

Report / Rapport: 061-S-77c-6.2

U.S. ENVIRONMENTAL PROTECTION AGENCY

Certified to comply with 2015 particulate emission standards at 1.8 g/hr EPA Method 28 and 5G. Not approved for sale after May 15, 2020. Input Rating: 38,700 Btu's/hr

THIS WOOD HEATER NEEDS PERIODIC INSPECTION AND REPAIR FOR PROPER OPERATION. CONSULT THE OWNER'S MANUAL FOR FURTHER INFORMATION. IT IS AGAINST FEDERAL REGULATIONS TO OPERATE THIS WOOD HEATER IN A MANNER INCONSISTENT WITH THE OPERATING INSTRUCTIONS IN THE OWNER'S MANUAL.

DO NOT REMOVE THIS LABEL / NE PAS ENLEVER L'ÉTIQUETTE

**SAMPLE:**  
**SERIAL NUMBER LABEL**  
**LOCATION:**  
**Behind left access panel.**

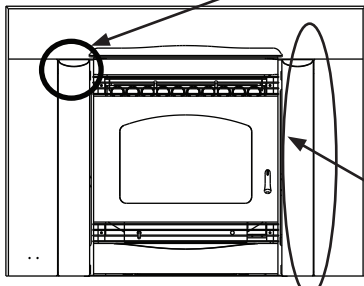

Tested and Listed by Portland Oregon USA  
OMNI-Test Laboratories, Inc.

Report No.  
#061-S-77d-6.2

**SAFETY LABEL**

**QUADRA-FIRE**

**Santa Fe Pellet Insert-MBK**

Input Rating: 30,000 BTU/HR.  
Electrical Rating: 115 VAC, 60 Hz, Start 4.1 Amps, Run 1.1 AMPS.

Manufactured by:

HEARTH & HOME Technologies  
1445 Highway North, Colville, WA 99114  
www.quadrafire.com

Listed Solid Fuel Room Heater/Pellet Type Insert. Also suitable for Mobile Home Installation. This appliance has been tested and listed for use in Manufactured Homes in accordance with OAR 814-23-9000 through 814-23-909.

Tested to: ASTM E-1509-2004, ULC S628-93, ULC /ORD-C1482-M1990 Room Heating Pellet Burning Type, (UM) 84-HUD FOR USE ONLY WITH PELLETED WOOD OR SHELLED FIELD CORN FUEL. Do not use any other type of fuel. OMNI-Test Laboratories, Inc. has determined that this appliance complies with Canadian Standards Association (CSA) B415.1 and Title 40 of the U.S. Code of Federal Regulations, Part 60, SubPart AAA. OMNI-Test Laboratories Accreditions: The Standards Council of Canada, the American National Standards Institute, and the U.S. Environmental Protection Agency. Route power cord away from unit. Do not route cord under or in front of appliance. DANGER: Risk of electrical shock. Disconnect power supply before servicing. Replace glass only with 5mm ceramic available from your dealer. To start, set thermostat above room temperature, the appliance will light automatically. To shutdown, set thermostat to below room temperature. For further instruction refer to owner's manual. KEEP VIEWING AND ASH REMOVAL DOORS TIGHTLY CLOSED DURING OPERATION.

PREVENT HOUSE FIRES

Install and use only in accordance with manufacturer's installation and operating instructions. CONTACT LOCAL BUILDING OR FIRE OFFICIALS ABOUT RESTRICTIONS AND INSTALLATION INSPECTION IN YOUR AREA. WARNING - FOR MOBILE HOMES: Do not install appliance in a sleeping room. An outside combustion air inlet must be provided. The structural integrity of the mobile home floor, ceiling and walls must be maintained. Refer to manufacturer's instructions and local codes for precautions required for passing chimney through a combustible wall or ceiling. Inspect and clean vent system frequently in accordance with manufacturer's instructions. Do Not Connect This Unit to a Chimney Serving Another Appliance. Use a 3" or 4" diameter type "L" or "PL" venting system.

MINIMUM CLEARANCES TO COMBUSTIBLE MATERIALS AS A BUILT-IN UNIT

A Top of Hopper	Top Vent	2.0 in.	51mm
	Rear Vent	2.5 in.	64mm
B Side of Hopper	Top/Rear Vent	2.0 in.	51mm
C Back of Hopper	Top/Rear Vent	2.5 in.	64mm
D Vent Pipe To Combustible	Top/Rear Vent	3.0 in.	76mm

0 in. Clearance To Exposed Section And Face Trim

Masonry or Zero Clearance

A Insert side to combustible side wall	16 in.	406mm
B Insert top to mantel	12 in.	305mm
C Insert top to max. 2.25 in. to top face trim	4.75 in.	121mm
D Insert side to max. 2.25 in. to side face trim	10 in.	254mm
E Hearth extension to from door opening - front	6 in.	152mm
F Hearth extension from side of door opening	6 in.	152mm

\*When constructing floor protection for your pellet appliance, any parts or materials used, must be non-combustible.

DO NOT REMOVE THIS LABEL 7019-223D

**SAMPLE: CLEARANCE TO COMBUSTIBLES LABEL**  
**LOCATION: On chain behind right access panel**



**Safety Alert Key:**

- **DANGER!** Indicates a hazardous situation which, if not avoided will result in death or serious injury.
- **WARNING!** Indicates a hazardous situation which, if not avoided could result in death or serious injury.
- **CAUTION!** Indicates a hazardous situation which, if not avoided, could result in minor or moderate injury.
- **NOTICE:** Indicates practices which may cause damage to the appliance or to property.

**TABLE OF CONTENTS**

<p>A. Congratulations.....2                  B. Sample of Serial Number / Safety Label.....2                  C. Warranty Policy .....4</p> <p><b>1 Listing and Code Approvals ..... 6</b></p> <p>A. Appliance Certification .....6                  B. BTU &amp; Efficiency Specifications.....6                  C. Glass Specifications .....6                  D. Electrical Rating.....6                  E. Mobile Home Approved .....6</p> <p><b>2 Operating Instructions ..... 7</b></p> <p>A. Fire Safety .....7                  B. Non-Combustible Materials .....7                  C. Combustible Materials .....7                  D. Fuel Material and Fuel Storage .....7                  E. General Operating Information .....8                  F. Before Your First Fire .....8                  G. Starting Your First Fire .....8                  H. Fire Characteristics.....9                  I. Feed Rate Adjustment Instructions .....9                  J. Ignition Cycles .....9                  K. Insert Removal.....9                  L. Clear Space .....10                  M. Frequently Asked Questions .....10</p>	<p><b>3 Maintenance and Service ..... 11</b></p> <p>A. Quick Reference Maintenance Chart.....11                  B. General Maintenance and Cleaning .....12                  C. High Ash Fuel Content Maintenance .....14                  D. Thermostat Battery Installation and Replacement.....15</p> <p><b>4 Troubleshooting Guide..... 16</b></p> <p><b>5 Service Parts Replacement..... 17</b></p> <p>A. Blower Replacement.....17                  B. Baffle &amp; Brick Replacement.....18                  C. Re-installing Baffle &amp; Brick Set.....18                  D. Igniter Replacement .....20                  E. Glass Replacement .....20</p> <p><b>6 Reference Materials ..... 21</b></p> <p>A. Component Functions .....21                  B. Component Locations.....23                  C. Exploded Drawings &amp; Service Parts.....24</p>
---	--

C. Warranty Policy

**Hearth & Home Technologies Inc.  
LIMITED LIFETIME WARRANTY**

Hearth & Home Technologies Inc., on behalf of its hearth brands ("HHT"), extends the following warranty for HHT gas, wood, pellet, coal and electric hearth appliances that are purchased from an HHT authorized dealer.

**WARRANTY COVERAGE:**

HHT warrants to the original owner of the HHT appliance at the site of installation, and to any transferee taking ownership of the appliance at the site of installation within two years following the date of original purchase, that the HHT appliance will be free from defects in materials and workmanship at the time of manufacture. After installation, if covered components manufactured by HHT are found to be defective in materials or workmanship during the applicable warranty period, HHT will, at its option, repair or replace the covered components. HHT, at its own discretion, may fully discharge all of its obligations under such warranties by replacing the product itself or refunding the verified purchase price of the product itself. The maximum amount recoverable under this warranty is limited to the purchase price of the product. This warranty is subject to conditions, exclusions and limitations as described below.

**WARRANTY PERIOD:**

Warranty coverage begins on the date of original purchase. In the case of new home construction, warranty coverage begins on the date of first occupancy of the dwelling or six months after the sale of the product by an independent, authorized HHT dealer/ distributor, whichever occurs earlier. The warranty shall commence no later than 24 months following the date of product shipment from HHT, regardless of the installation or occupancy date. The warranty period for parts and labor for covered components is produced in the following table.

The term "Limited Lifetime" in the table below is defined as: 20 years from the beginning date of warranty coverage for gas appliances, and 10 years from the beginning date of warranty coverage for wood, pellet, and coal appliances. These time periods reflect the minimum expected useful lives of the designated components under normal operating conditions.

Warranty Period		HHT Manufactured Appliances and Venting							Components Covered
Parts	Labor	Gas	Wood	Pellet	EPA Wood	Coal	Electric	Venting	
1 Year		X	X	X	X	X	X	X	All parts and material except as covered by Conditions, Exclusions, and Limitations listed
2 years				X	X	X			Igniters, electronic components, and glass
		X	X	X	X	X			Factory-installed blowers
			X						Molded refractory panels
3 years				X					Firepots and burnpots
5 years	1 year			X	X				Castings and baffles
7 years	3 years		X	X	X				Manifold tubes, HHT chimney and termination
10 years	1 year	X							Burners, logs and refractory
Limited Lifetime	3 years	X	X	X	X	X			Firebox and heat exchanger
90 Days		X	X	X	X	X	X	X	All replacement parts beyond warranty period

See conditions, exclusions, and limitations on next page.

**WARRANTY CONDITIONS:**

- This warranty only covers HHT appliances that are purchased through an HHT authorized dealer or distributor. A list of HHT authorized dealers is available on the HHT branded websites.
- This warranty is only valid while the HHT appliance remains at the site of original installation.
- Contact your installing dealer for warranty service. If the installing dealer is unable to provide necessary parts, contact the nearest HHT authorized dealer or supplier. Additional service fees may apply if you are seeking warranty service from a dealer other than the dealer from whom you originally purchased the product.
- Check with your dealer in advance for any costs to you when arranging a warranty call. Travel and shipping charges for parts are not covered by this warranty.

**WARRANTY EXCLUSIONS:**

This warranty does not cover the following:

- Changes in surface finishes as a result of normal use. As a heating appliance, some changes in color of interior and exterior surface finishes may occur. This is not a flaw and is not covered under warranty.
- Damage to printed, plated, or enameled surfaces caused by fingerprints, accidents, misuse, scratches, melted items, or other external sources and residues left on the plated surfaces from the use of abrasive cleaners or polishes.
- Repair or replacement of parts that are subject to normal wear and tear during the warranty period. These parts include: paint, wood, pellet and coal gaskets, firebricks, grates, flame guides, light bulbs, batteries and the discoloration of glass.
- Minor expansion, contraction, or movement of certain parts causing noise. These conditions are normal and complaints related to this noise are not covered by this warranty.
- Damages resulting from: (1) failure to install, operate, or maintain the appliance in accordance with the installation instructions, operating instructions, and listing agent identification label furnished with the appliance; (2) failure to install the appliance in accordance with local building codes; (3) shipping or improper handling; (4) improper operation, abuse, misuse, continued operation with damaged, corroded or failed components, accident, or improperly/incorrectly performed repairs; (5) environmental conditions, inadequate ventilation, negative pressure, or drafting caused by tightly sealed constructions, insufficient make-up air supply, or handling devices such as exhaust fans or forced air furnaces or other such causes; (6) use of fuels other than those specified in the operating instructions; (7) installation or use of components not supplied with the appliance or any other components not expressly authorized and approved by HHT; (8) modification of the appliance not expressly authorized and approved by HHT in writing; and/or (9) interruptions or fluctuations of electrical power supply to the appliance.
- Non-HHT venting components, hearth components or other accessories used in conjunction with the appliance.
- Any part of a pre-existing fireplace system in which an insert or a decorative gas appliance is installed.
- HHT's obligation under this warranty does not extend to the appliance's capability to heat the desired space. Information is provided to assist the consumer and the dealer in selecting the proper appliance for the application. Consideration must be given to appliance location and configuration, environmental conditions, insulation and air tightness of the structure.

**This warranty is void if:**

- The appliance has been over-fired or operated in atmospheres contaminated by chlorine, fluorine, or other damaging chemicals. Over-firing can be identified by, but not limited to, warped plates or tubes, rust colored cast iron, bubbling, cracking and discoloration of steel or enamel finishes.
- The appliance is subjected to prolonged periods of dampness or condensation.
- There is any damage to the appliance or other components due to water or weather damage which is the result of, but not limited to, improper chimney or venting installation.

**LIMITATIONS OF LIABILITY:**

- The owner's exclusive remedy and HHT's sole obligation under this warranty, under any other warranty, express or implied, or in contract, tort or otherwise, shall be limited to replacement, repair, or refund, as specified above. In no event will HHT be liable for any incidental or consequential damages caused by defects in the appliance. Some states do not allow exclusions or limitation of incidental or consequential damages, so these limitations may not apply to you. This warranty gives you specific rights; you may also have other rights, which vary from state to state. EXCEPT TO THE EXTENT PROVIDED BY LAW, HHT MAKES NO EXPRESS WARRANTIES OTHER THAN THE WARRANTY SPECIFIED HEREIN. THE DURATION OF ANY IMPLIED WARRANTY IS LIMITED TO DURATION OF THE EXPRESSED WARRANTY SPECIFIED ABOVE.

# 1 Listing and Code Approvals

## A. Appliance Certification

<b>Model</b>	Santa Fe Pellet Insert
<b>Laboratory</b>	OMNI Test Laboratories, Inc.
<b>Report No.</b>	061-S-77d-6.2
<b>Type</b>	Solid Fuel Room Heater/Pellet Fuel Burning Type Insert
<b>Standard</b>	ASTM E1509-2004, ULC S628-93 and ULC/ORD-C1482-M1990 Room Heater Pellet Fuel Burning Type and (UM) 84-HUD, Mobile Home Approved
<b>FCC</b>	Complies with Part 15 of FCC Rules. Operation is subject to the following two conditions: (1) this device may not cause harmful interference, and (2) this device must accept any interference received, including interference that may cause undesired operation.

**NOTE:** This installation must conform with local codes. In the absence of local codes you must comply with the **ASTM E1509-2004, ULC S628-93, ULC/ORD-C-1482-M1990, (UM) 84-HUD**

The Quadra-Fire Santa Fe Pellet Insert meets the U.S. Environmental Protection Agency’s emission limits for pellet inserts sold after May 15, 2015.

This pellet insert needs periodic inspection and repair for proper operation. It is against federal regulations to operate this pellet insert in a manner inconsistent with operating instructions in this manual.

## B. BTU & Efficiency Specifications

EPA Certification #:	940-14
EPA Certified Emissions:	1.8 grams per hour
*LHV Tested Efficiency:	N/A
**HHV Tested Efficiency:	N/A
***EPA BTU Output:	8,500 to 28,200 / hr.
****BTU Input:	11,600 to 38,700 / hr.
Vent Size:	3 or 4 inches, “L” or “PL”
Hopper Capacity:	45 lbs.
Fuel	Wood Pellets
* Weighted average LHV efficiency using data collected during EPA emissions test.	
**Weighted average HHV efficiency using data collected during EPA emissions test.	
***A range of BTU outputs based on EPA Default Efficiency and the burn rates from the low and high EPA tests.	
****Based on the maximum feed rate per hour multiplied by approximately 8600 BTU’s which is the average BTU’s from a pound of pellets.	

## C. Glass Specifications

This stove is equipped with 5mm ceramic glass. Replace glass only with 5mm ceramic glass. Please contact your dealer for replacement glass.

## D. Electrical Rating

115 VAC, 60 Hz, Start 4.1 Amps, Run 1.1 Amp

## E. Mobile Home Approved

- This appliance is approved for mobile home installations when not installed in a sleeping room and when an outside combustion air inlet is provided.
- The structural integrity of the mobile home floor, ceiling, and walls must be maintained.
- The appliance must be properly grounded to the frame of the mobile home and use only Listed pellet vent Class “L” or “PL” connector pipe.
- Outside Air Kit, part OAK-ACC must be installed in a mobile home installation.

### WARNING



#### Fire Risk.

Hearth & Home Technologies disclaims any responsibility for, and the warranty will be voided by, the following actions:

- Installation and use of any damaged appliance.
- Modification of the appliance.
- Installation other than as instructed by Hearth & Home Technologies.
- Installation and/or use of any component part not approved by Hearth & Home Technologies.
- Operating appliance without fully assembling all components.
- Operating appliance without legs attached (if supplied with unit).
- Do NOT Overfire - If appliance or chimney connector glows, you are overfiring.

Any such action that may cause a fire hazard.

Improper installation, adjustment, alteration, service or maintenance can cause injury or property damage.

For assistance or additional information, consult a qualified installer, service agency or your dealer.



**NOTE:** Hearth & Home Technologies, manufacturer of this appliance, reserves the right to alter its products, their specifications and/or price without notice.

Quadra-Fire is a registered trademark of Hearth & Home Technologies.



# User Guide

## 2 Operating Instructions

 <b>WARNING</b>	
	<p><b>Fire Risk.</b></p> <ul style="list-style-type: none"> <li>Do not operate appliance before reading and understanding operating instructions.</li> <li>Failure to operate appliance properly may cause a house fire.</li> </ul>

### A. Fire Safety

To provide reasonable fire safety, the following should be given serious consideration:

- Install at least one smoke detector and CO monitor on each floor of your home.
- Locate detectors away from the heating appliance and close to the sleeping areas.
- Follow the detector's manufacturer's placement and installation instructions and maintain regularly.
- A CO detector should be installed in the room with the appliance.
- Conveniently locate a Class A fire extinguisher to contend with small fires.
- In the event of a hopper fire:
  - Evacuate the house immediately.
  - Notify fire department.

### B. Non-Combustible Materials

Material which will not ignite and burn, composed of any combination of the following:

- Steel
- Plaster
- Glass
- Tile
- Brick
- Iron
- Slate
- Concrete

Materials reported as passing **ASTM E 136, Standard Test Method for Behavior of Metals, in a Vertical Tube Furnace of 750° C.**

### C. Combustible Materials

Material made of/or surfaced with any of the following materials:

- Compressed Paper
- Wood
- Plywood/OSB
- Sheet Rock (drywall)
- Plastic
- Plant Fibers

Any material that can ignite and burn: flame proofed or not, plastered or un-plastered.

### D. Fuel Material and Fuel Storage

Pellet fuel quality can greatly fluctuate. This appliance has been designed to burn a wide variety of fuels, giving you the choice to use the fuel that is most economical in your region.

Hearth & Home Technologies strongly recommends only using Pellet Fuel Institute (PFI) certified fuel.

#### Fuel Material

- Made from sawdust or wood by-products
- Shelled field corn & other biomass fuels
- Depending on the source material it may have a high or low ash content.

#### Higher Ash Content Material

- Hardwoods with a high mineral content
- Fuel that contains bark
- Standard grade pellets, high ash pellets, corn and other biomass fuels

#### Lower Ash Content Material

- Softwoods
- Fuels with low mineral content
- Premium grade pellets

#### Shelled Field Corn

- Must be 15% or less moisture content.
- Must be clean and free from debris
- Never burn corn straight from the field
- Stalk parts, excessive fines and cob remnants, etc. will clog the auger mechanism

 <b>CAUTION</b>	
<b>Do not burn fuel that contains an additive; (such as soybean oil).</b>	
<ul style="list-style-type: none"> <li>May cause hopper fires</li> <li>Damage to product may result</li> </ul>	
Read the ingredients list on the package. If you are buying corn the only ingredient that should be listed is corn.	

 <b>WARNING</b>	
<b>Risk of Chemical Poisoning!</b>	
Do NOT burn treated seed corn	
<ul style="list-style-type: none"> <li>Chemical pesticides are harmful or fatal if swallowed</li> <li>Burning treated seed corn will void your warranty</li> </ul>	

- Corn with excessive grain dust must be screened by sifting with 3/16 inch (4.7mm) mesh screening

#### Clinkers

Minerals and other non-combustible materials such as sand will turn into a hard, glass-like substance called a clinker when heated in the firepot.

Trees from different areas will vary in mineral content. That is why some fuels produce more clinkers than others.

#### Moisture

Always burn dry fuel. Burning fuel with high moisture content takes heat from the fuel and tends to cool the appliance, robbing heat from your home. Damp pellet fuel can clog the feed system.

**E. General Operating Information**

**1. Thermostat Calls For Heat**

The appliance is like most modern furnaces; when the thermostat calls for heat, your appliance will automatically light and deliver heat. When the room is up to temperature and the thermostat is satisfied, the red call light will shut off and the appliance will shut down. The red call light is located behind the left access panel.

**2. Heat Output Controls**

This appliance is equipped with a heat output control switch that has three settings or burn rates; low, medium and high. The appliance will turn on and off as the thermostat demands. When the thermostat calls for heat, the appliance will always start up on High. After burning approximately 4 minutes, the appliance will then burn at the rate at which it was originally set. If the appliance is set at one of the lower settings, it will run quieter but takes longer to heat up an area than if it were set at a higher burn rate. Regardless of the burn rate, when the area is warm enough to satisfy the thermostat, the appliance will shut off.

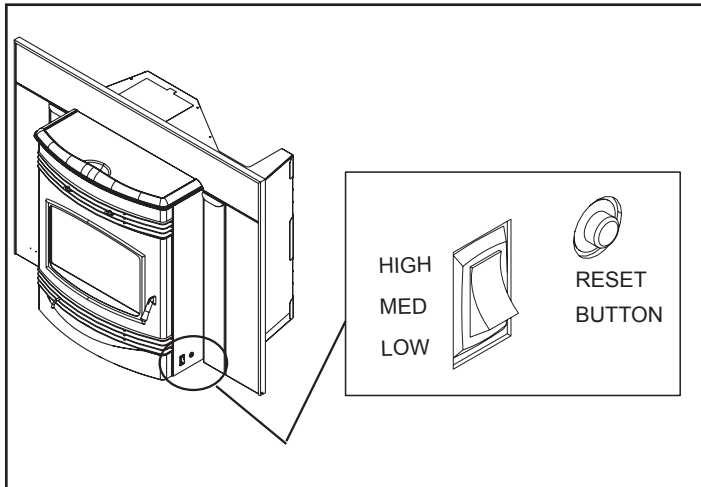



Figure 8.1

<b>WARNING</b>	
	<p><b>Fire Hazard.</b> Keep combustible materials, gasoline and other flammable vapors and liquids clear of appliance.</p> <ul style="list-style-type: none"> <li>• Do NOT store flammable materials in the appliance's vicinity.</li> <li>• NEVER USE GASOLINE, GASOLINE-TYPE LANTERN FUEL, KEROSENE, CHARCOAL LIGHTER FLUID, OR SIMILAR LIQUIDS TO START OR "FRESHEN UP" A FIRE IN THIS HEATER. KEEP ALL SUCH LIQUIDS WELL AWAY FROM THE HEATER WHILE IT IS IN USE.</li> <li>• DO NOT BURN GARBAGE OR FLAMMABLE FLUIDS SUCH AS GASOLINE, NAPHTHA OR ENGINE OIL.</li> <li>• DO NOT USE CHEMICALS OF FLUIDS TO START THE FIRE.</li> <li>• Combustible materials may ignite.</li> </ul>

**F. Before Your First Fire**

1. First, make sure your appliance has been properly installed and that all safety requirements have been met. Pay particular attention to the fire protection, venting and thermostat installation instructions.
2. Double check that the ash drawer and firebox are empty!
3. Check the position of the thermocouple, located above the firepot, and make sure that it protrudes approximately 3/4 inch (19mm) into the firepot.
4. Close the front door.

<b>CAUTION</b>
<p>Tip of thermocouple must be in contact with the inside end of the thermocouple cover.</p> <p>Missed ignitions can occur.</p>

**G. Starting Your First Fire**

1. A thermostat is required for proper operation of this appliance, except for corn. At this time, fill the hopper with pellets, set the thermostat to its lowest setting. Plug the power cord into nearby outlet.
2. The exhaust blower will stay on for approximately 18 minutes even though the thermostat is not calling for heat. This is normal.
3. Locate the heat output control switch on the lower right side of the firebox in front of the right access panel. Set to the HIGH setting and then adjust the thermostat to its highest setting. The red call light will be on which is located on the front of the junction box behind the left access panel. This indicates the thermostat is calling for heat. **Figure 9.1.**
4. The fuel feed system and the igniter should now be on.
5. For your first fire it will be necessary to press the reset button once a minute until pellets start to drop into the firepot, then press button 1 more time. This will fill the feed system and allow the appliance to begin dropping pellets. The appliance will continue to run as long as the thermostat is calling for heat.
6. Once the appliance has ignited, let it burn for approximately 15 minutes, then set the thermostat to the desired room temperature. Adjust the heat output control switch to the desired setting.

<b>WARNING</b>	
	<p><b>Fire Risk</b> Do NOT operate appliance:</p> <ul style="list-style-type: none"> <li>• With appliance door open.</li> <li>• Firepot floor open.</li> <li>• Cleaning slide plates open.</li> </ul> <p>Do NOT store fuel:</p> <ul style="list-style-type: none"> <li>• Closer than required clearances to combustibles to appliance</li> <li>• Within space required for loading or ash removal.</li> </ul>



## H. Fire Characteristics

A properly adjusted fire with the heat output control button set on "HIGH" has a short active flame pattern that extends out of the firepot approximately 4 inches (102mm). If the fire has tall flames with black tails and seems somewhat lazy, the feed rate will need to be reduced. If the fire is not 4 inches (102mm) tall, increase the feed rate. A medium and low setting will give a shorter flame. The flame will rise and fall somewhat. This is normal.

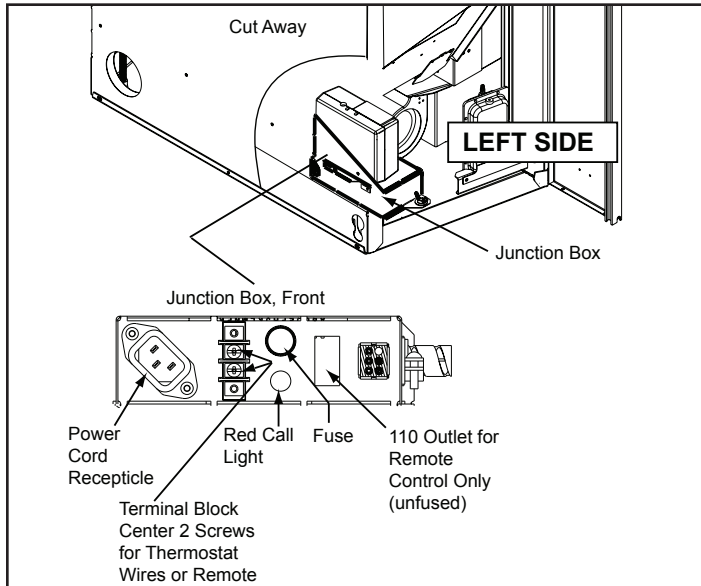



Figure 9.1

## I. Feed Rate Adjustment Instructions

The feed adjustment control rod is factory set, and should be adequate for most fuels. The set screw is located at the bottom of the hopper and *set loose at the factory* so the fuel adjustment control rod will slide by only loosening the wing nut. Do not re-tighten bottom set screw.

However, if the flame height is too high or too low, you will need to adjust the feed rate. Wait until the appliance has been burning for 15 minutes before making your adjustments and allow 15 minutes for feed adjustment to take effect. Make adjustments in approximately 1/2 inch increments.

1. Loosen the wing nut. **Figure 9.2.**
2. Adjust the fuel adjustment control rod towards the "+" symbol to increase the feed rate and flame height or towards the "-" symbol, to decrease the feed rate and flame height.
3. Re-tighten the wing nut.



**WARNING**



**Fire Risk.**

- High ask fuels, or lack of maintenance, can cause the firepot to fill with ash and clinker. If the firepot fills to the top, immediately shut down the appliance and clean.
- Failure to do so could result in smoking, sooting and possible hoper fires.

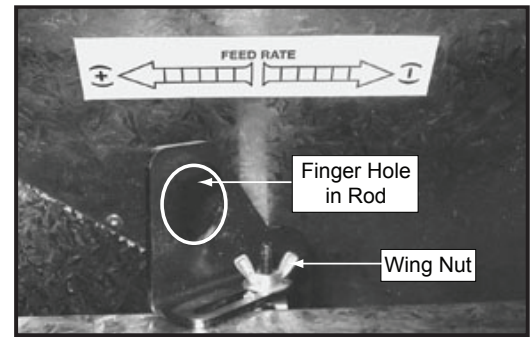

Figure 9.2

## J. Ignition Cycles

1. During each ignition cycle, it is normal to see some smoke in the firebox. The smoke will stop once the fire starts.
2. The convection blower will automatically turn on after your appliance has reached the set temperature. This blower transfers heat from your appliance into the room, and will continue to run after the thermostat has stopped calling for heat until the appliance has cooled down.
3. Occasionally the appliance may run out of fuel and shut itself down. When this happens, the red call light will be on. To restart it, fill the hopper and press the reset button. When you press the reset button the red call light will go out. Release the button and the light will come back on. You should see a fire shortly. If not, follow the instructions on **page 8**, "Starting Your First Fire".

## K. Insert Removal

In the case that service or inspection is required the unit may need to be removed from the wall.

1. Unit must be unplugged before removal of unit is possible. Unplug the unit from its power source.
2. Remove insert surround from unit, to ease the process of removal.
3. Unclip the exhaust transition from the exhaust outlet in the back of the unit. This is what connects the venting to the unit. Removal of the clips will allow you to remove the unit from the wall without damaging or adjusting the venting.
4. Slide unit from the wall and rotate either direction as needed.

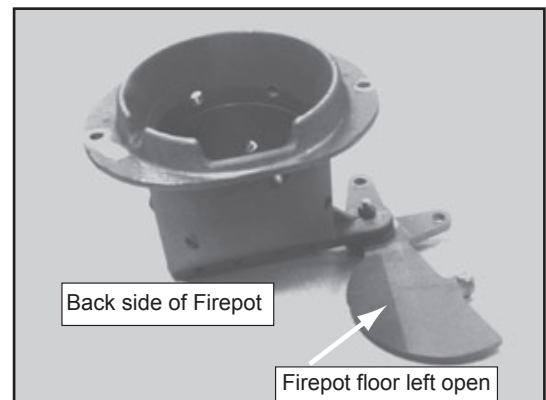



Figure 9.3 - DO NOT LEAVE FIREPOT FLOOR OPEN



## Santa Fe Pellet Insert

### L. Clear Space

**Mantel:** Avoid placing candles and other heat-sensitive objects on mantel or hearth. Heat may damage these objects.

**NOTICE:** Clearances may only be reduced by means approved by the regulatory authority having jurisdiction.

 <b>WARNING</b>
 <p><b>Fire Risk.</b> Do NOT place combustible objects in front of the appliance. High temperatures may ignite clothing, furniture or draperies. Maintain a minimum clearance of 3 feet (914mm) in front of appliance.</p>

 <b>WARNING</b>
 <p><b>Fire Risk.</b> Keep combustible materials, gasoline and other flammable vapors and liquids clear of appliance.</p> <ul style="list-style-type: none"> <li>• Do NOT store flammable materials in the appliance's vicinity.</li> <li>• <b>DO NOT USE GASOLINE, LANTERN FUEL, KEROSENE, CHARCOAL LIGHTER FLUID OR SIMILAR LIQUIDS TO START OR "FRESHEN UP" A FIRE IN THIS HEATER.</b></li> <li>• <b>DO NOT BURN GARBAGE OR FLAMMABLE FLUIDS SUCH AS GASOLINE, NAPHTHA OR ENGINE OIL.</b></li> <li>• <b>DO NOT USE CHEMICALS OR FLUIDS TO START THE FIRE.</b></li> <li>• Keep all such liquids well away from the heater while it is in use.</li> <li>• Combustible materials may ignite.</li> </ul>

### M. Frequently Asked Questions

ISSUES	SOLUTIONS
1. Metallic noise	1. Noise is caused by metal expanding and contracting as it heats up and cools down, similar to the sound produced by a furnace or heating duct. This noise does not affect the operation or longevity of your appliance.
2. Ash build-up on glass	2. This is normal. Clean the glass.
3. Glass has turned dirty	3. Excessive build up of ash. The lower burn settings will produce more ash, the higher burn settings produce less. The more it burns on low the more frequent cleaning of the glass is required.
4. Fire has tall flames with black tails and is lazy	4. The flame height adjustment needs to be reduced or the firepot needs cleaning. Heat exchanger or exhaust blower needs cleaning.
5. Excessive smoky start-up	5. Either the firepot is dirty or there is too much fuel at start-up and not enough air.
6. Large flame at start-up	6. This is normal. Flame will settle down once the fire is established. Some smoke is normal.
7. Mechanical Noise	7. The floor of the firepot in the auto-clean system may make some noise as it scrapes the ash into the ash pan.

**CONTACT YOUR DEALER** for additional information regarding operation and troubleshooting.  
Visit [www.quadrafire.com](http://www.quadrafire.com) to find a dealer.

<b>CAUTION</b>
<p>Odors and vapors released during initial operation.</p> <ul style="list-style-type: none"> <li>• Curing of high temperature paint.</li> <li>• Open windows for air circulation.</li> </ul> <p>Odors may be irritating to sensitive individuals.</p>

# 3 Maintenance and Service

When properly maintained, your fireplace will give you many years of trouble-free service. Contact your dealer to answer question regarding proper operation, troubleshooting and service for your appliance. Visit [www.quadrafire.com](http://www.quadrafire.com) to find a dealer. We recommend annual service by a qualified service technician.

This pellet insert has a manufacturer-set minimum low burn rate that must not be altered. It is against federal regulations to alter this setting or otherwise operate this pellet insert in a manner inconsistent with operating instructions in this manual.

 **CAUTION**



**Shock and Smoke Hazard**

- Turn down thermostat, let appliance completely cool and exhaust blower must be off. Now you can unplug appliance before servicing.
- Smoke spillage into room can occur if appliance is not cool before unplugging.
- Risk of shock if appliance not unplugged before servicing appliance.

## A. Quick Reference Maintenance Chart

Cleaning or Inspection	Frequency		Daily	Weekly	Every 2 Weeks	Monthly	Yearly
Ash Pan - Burning Wood Pellets	Every 5 bags of fuel	OR		X			
Ash Pan - Burning Alternate Fuels	Every 1 bag of fuel	OR	X				
Ash Removal from Firebox	More frequently depending on the fuel type or ash build-up	OR		X			
Auto-Clean Inspection	More frequently depending on the fuel type	OR				X	
Blower, Combustion (Exhaust)	More frequently depending on the fuel type	OR					X
Blower, Convection	More frequently depending on the operating environment	OR					X
Door Latch Inspection	Prior to heating season	OR				X	
Firebox - Prepare for Non-Burn Season	At end of heating season	OR					X
Firepot - Burning Softwood Pellets	Every 5 bags	OR		X			
Firepot - Burning Hardwood Pellets	Every 3 bags	OR		X			
Firepot - Burning Alternate Fuels	Every 1 bag	OR	X				
Glass	When clear view of firepot becomes obscured	OR		X			
Heat Exchanger & Drop Tube	Every 1 ton of fuel	OR			X		
Hopper	Every 1 ton of fuel or when changing fuel types	OR				X	
Venting System	More frequently depending on the fuel type	OR					X

**NOTICE:** These are recommendations. Clean more frequently if you encounter heavy build-up of ash at the recommended interval or you see soot coming from the vent. Not properly cleaning your appliance on a regular basis will void your warranty.

## B. General Maintenance and Cleaning

### 1. Types of Fuel

Depending on the type of fuel you are burning will dictate how often you have to clean your firepot.

If the fuel you are burning has a high dirt or ash content or you are burning shelled field corn, it may be necessary to clean the firepot more than once a day.

Dirty fuel will cause clinkers to form in the firepot. A clinker is formed when dirt, ash or a non-burnable substance is heated to 2000°F (1093°C) and becomes glass-like. See **page 14** in this section for more details on fuels with high ash content.

### 2. Cleaning Firepot with Cleaning Rod & Firepot Clean-Out Tool

- **Frequency:** Daily or more often as needed
- **By:** Homeowner
  - a. The appliance must be in complete shutdown and cool and the exhaust blower off. NOTE: If you are just cleaning the firepot, there is no need to unplug the insert.
  - b. Pull firepot cleaning rod OUT and IN a couple of times to help shake debris loose. **See page 13.**

If rod is hard to pull, it may be necessary to use your firepot clean-out tool to chip away material that has built up on the bottom plate of the firepot and to push out any clinkers. Larger clinkers may have to be removed from the top of the firepot. Corn clinkers can be especially difficult to break up.
  - c. The firepot floor plate must be fully closed when finished. **See Figure 9.3 on page 9.**

### 3. Ash Removal from Firebox

- **Frequency:** Weekly or more frequently depending on ash build-up
- **By:** Homeowner
  - a. There must not be any hot ashes in the firebox during cleaning so allow the appliance to completely cool. Frequent cleaning of the ash in the firebox will help slow down the build-up of ash in the exhaust blower and vent system.
  - b. Plug in your appliance, if unplugged, and turn the thermostat on and immediately shut it off to start the exhaust blower on its cycle time. It will pull fly ash out the exhaust instead of into the room.
  - c. Open door. There are 2 cleaning slide plates to the left and right of the firepot with finger holes. Pull both slide plates out and sweep the remaining ash from the firebox into the 2 open holes. A paint brush works well for this. Close slide plates.
  - d. This ash is deposited in the same ash drawer as the firepot debris. The ash drawer should be emptied every

time you clean the firebox. Remember to place the ash and debris into a metal or non-combustible container.

- e. The 2 cleaning slide plates must be fully closed when cleaning is complete.

### 4. Cleaning Ash Drawer

- **Frequency:** Weekly or every 5 bags of fuel
- **By:** Homeowner

Locate the ash drawer underneath the firepot and slide the ash drawer straight out. Empty into a non-combustible container and re-install ash drawer.

### 5. Disposal of Ashes

- **Frequency:** As needed
- **By:** Homeowner

Ashes should be placed in a metal container with a tight-fitting lid. The closed container of ashes should be placed on a non-combustible floor or on the ground, well away from all combustible materials, pending final disposal.

If the ashes are disposed of by burial in soil or otherwise locally dispersed, they should be retained in the closed container until all cinders have been thoroughly cooled.

#### **WARNING**



##### **Disposal of Ashes.**

- Ashes should be placed in metal container with tight fitting lid.
- Ashes should be retained in closed container until all cinders have thoroughly cooled.

#### **WARNING**



##### **Fire Risk.**

- NEVER pull firepot cleaning rods or cleaning slide plates when appliance is operating. Hot pellets may fall into ashpan and may start a fire or have mis-starts due to lack of vacuum.

#### **WARNING**



##### **Fire Risk.**

- The cleaning slide plates must be fully CLOSED when appliance is operating. Hot pellets may fall into ash pan and start a fire.

**6. Cleaning Heat Exchanger Chambers**

- **Frequency:** Weekly or every 1 ton of fuel
- **By:** Homeowner

The amount of ash buildup in the firebox will be a good guide to determine how often you should clean the heat exchangers.

- Allow the appliance to completely cool down before pulling the cleaning rods. Turn the thermostat on and then immediately off to start the exhaust blower on its cycle time. It will pull fly ash out the exhaust instead of into the room.
- Locate the 2 exposed rods directly underneath the heat exchanger tubes. **Figure 13.1.**
- To clean, pull the rods straight out until it stops, approximately 8 inches (203mm). Slide the rods OUT and IN a couple of times.

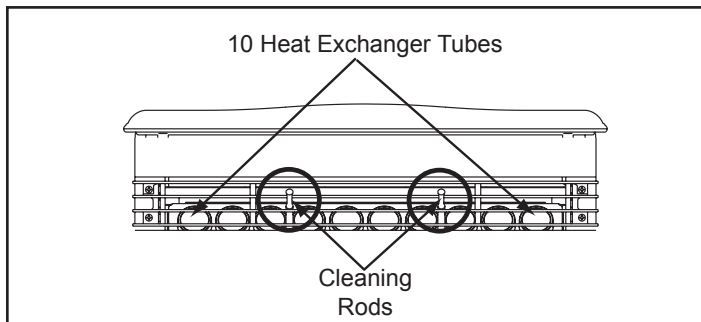



Figure 13.1

**WARNING**



Heat exchanger cleaning rods may be warm to the touch. For safety purposes wear gloves.

Do not pull heat exchanger cleaning rods while appliance is operating.



Push cleaning rods IN when done, DO NOT leave cleaning rods OUT. Injury can occur.

**7. Cleaning Beneath Heat Exchanger**

- **Frequency:** Monthly or every 1 ton of fuel
- **By:** Homeowner

A more thorough cleaning is needed to remove the excess ash that is left behind from the use of the cleaning rods for the heat exchanger tubes. The ash will be resting on the back of the baffle.

This will require removing the baffle and cast brick set. Please refer to **pages 17** for a detailed explanation of removing the baffle and brick set.

**NOTE: There are heavy duty vacuum cleaners specifically designed for solid fuel appliance cleaning.**

**8. Cleaning the Glass**

- **Frequency:** When clear view of the firepot is obscure
- **By:** Homeowner
  - Appliance must be completely cool before cleaning glass.
  - Use a damp paper towel or any non-abrasive glass cleaner. Wipe off with dry towel.

**CAUTION**

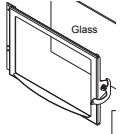

Handle glass assembly with care.

**When cleaning glass:**

- Avoid striking, scratching or slamming glass.
- Do NOT clean glass when hot.
- Do NOT use abrasive cleaners.

- Use a hard water deposit glass cleaner on white film.
- Refer to maintenance instructions.

**WARNING**

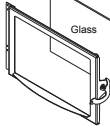

Handle glass with care.

- Inspect the gasket to ensure it is undamaged.
- Do NOT strike, slam or scratch glass.
- Do NOT operate appliance with glass assembly removed.

- Do NOT operate with glass cracked, broken or scratched.

**9. Door Latch Inspection**

- **Frequency:** Prior to heating season
- **By:** Homeowner

The door latch is non-adjustable but the gasketing between the glass and firebox should be inspected periodically to make sure there is a good seal.

NOTE: There is no gasket on the bottom of glass.

**10. Cleaning the Hopper**

- **Frequency:** Monthly or every 1 ton of fuel
- **By:** Homeowner

After burning approximately 1 ton of fuel you will need to clean the hopper to prevent sawdust build-up. A combination of sawdust and pellets on the auger reduces the amount of fuel supply to the firepot. This can result in nuisance shut-downs and mis-starts.

- The appliance must be in complete shutdown. Allow the appliance to completely cool down.
- Empty the hopper of any remaining pellets.
- Vacuum the hopper and feed tube.



## 11. Cleaning Exhaust Blower - Requires No Lubrication

- **Frequency:** Yearly or as needed
- **By:** Quality Service Technician/Homeowner
  - a. Remove left & right brick. The exhaust blower is behind the right brick. Vacuum this area thoroughly. See **page 17** for removing bricks. Re-install bricks when done.

## 12. Cleaning Convection Blower - Requires No Lubrication

- **Frequency:** Yearly or as needed
- **By:** Qualified Service Technician
- **Task:** **Contact your local dealer.**

## 13. Soot and Fly Ash: Formation & Need for Removal in Exhaust Venting System.



- **Frequency:** Yearly or more frequently depending on ash build-up
- **By:** Qualified Service Technician/Homeowner

The products of combustion will contain small particles of fly-ash. The fly-ash will collect in the exhaust venting system and restrict the flow of the flue gases. Incomplete combustion, such as occurs during startup, shutdown, or incorrect operation of the room heater will lead to some soot formation which will collect in the exhaust venting system. The exhaust venting system should be inspected at least once every year to determine if cleaning is necessary.

The venting system may need to be cleaned at least once a year or more often depending upon the quality of your fuel or if there is a lot of horizontal pipe sections. Ash will build up more quickly in the horizontal sections.

## 14. Preparing Firebox for Non-Burn Season

- **Frequency:** At the end of the heating season
- **By:** Homeowner
  - a. Be sure the appliance is allowed to cool, has been unplugged and the exhaust blower is off.
  - b. Remove all ash from the firebox and vacuum thoroughly.
  - c. Paint all exposed steel, including cast-iron.
    - Use the Touch-Up paint supplied with the appliance; or,
    - Purchase paint from your local dealer.
    - Must use a high-temperature paint made specifically for heating appliances.

 <b>WARNING</b>	
	<b>Fire Risk</b>
	- High ash fuels, or lack of maintenance, can cause the firepot to overflow. Follow proper shutdown procedure if ash build up exceeds half way point.
	- Failure to do so could result in smoking, sooting and possible hopper fires.

## C. High Ash Fuel Content Maintenance

- **Frequency:** When the ash build-up exceeds more than half way up the firepot.
  - **By:** Homeowner
- Poor quality pellet fuel, or lack of maintenance, can create conditions that make the firepot fill quickly with ashes and clinkers.

This condition makes the appliance susceptible to overflowing the firepot with pellets which may result in smoking, sooting and possible hopper fires. **Figure 14.1** shows an example where the firepot overfills, pellets back up into the feed tube and ash has accumulated in the firebox.

An inefficient and non-economical method of burning of fuel caused by poor quality pellet fuel is shown in **Figure 14.2**.

The correct flame size when good quality, premium pellet fuel is burned is shown in **Figure 14.3**.

If the ash buildup exceeds the half way point in the firepot **IMMEDIATE ATTENTION AND CLEANING IS REQUIRED.**

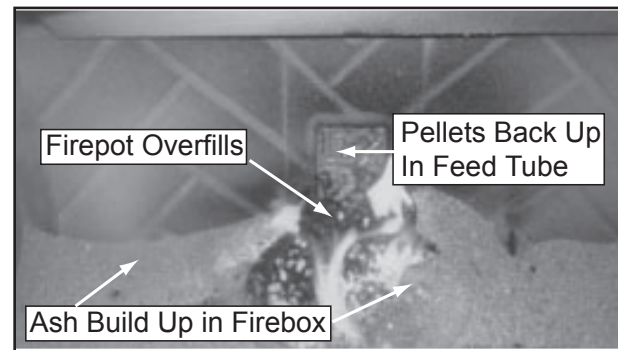

**Figure 14.1**

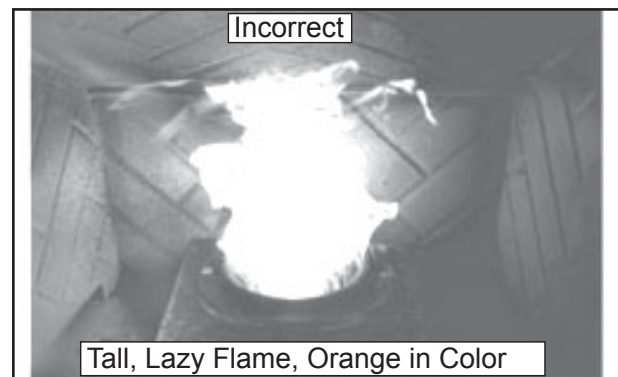

**Figure 14.2**

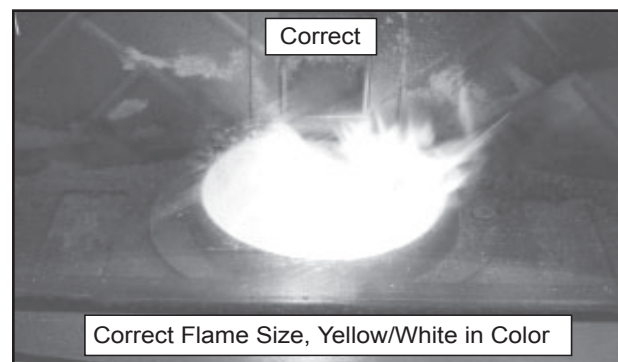

**Figure 14.3**

## D. Thermostat Battery Installation, Replacement, and Operation

**NOTE:** 2 AA batteries are included with the thermostat and must be installed before the appliance can be operated.

Install fresh batteries immediately when the **REPLACE BATTERY** warning begins flashing. The warning flashes about two months before the batteries are depleted. Even if the warning does not appear, you should replace batteries once a year (**Figure 15.1**).

If batteries are inserted within two minutes, the time and day will not have to be reset. All other settings are permanently stored in memory.



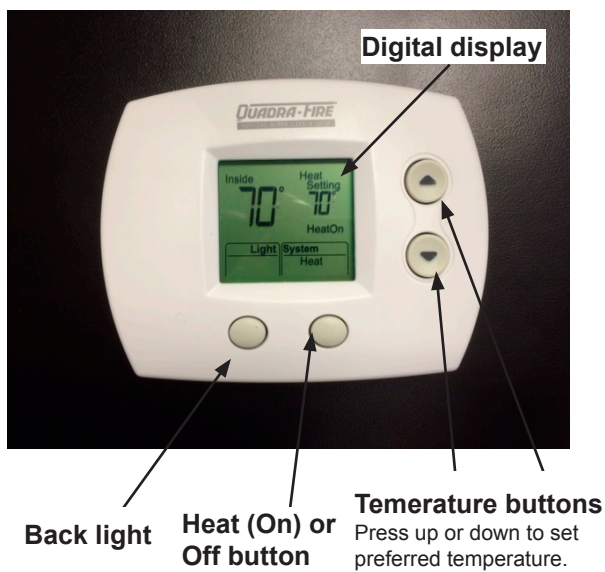

Figure 15.1

## Thermostat Operation



# 4 Troubleshooting Guide

With proper installation, operation, and maintenance your appliance will provide years of trouble-free service. If you do experience a problem, this troubleshooting guide will assist a qualified service person in the diagnosis of a problem and the corrective action to be taken. This troubleshooting guide can only be used by a qualified service technician.

Error Message	Possible Cause	Corrective Action
	Bad wall control or control board 3 wires have loose connections or installed wrong	Replace wall control or control board Check connections
BAD TC DROP TUBE (TC = Thermocouple)	Drop tube thermocouple is broken or leads are reversed	Check connections Replace thermocouple
BAD TC FIREPOT (TC = Thermocouple)	Firepot thermocouple is broken or leads are reversed	Check connections Replace thermocouple
SNAP DISC TRIPPED	Overheat sensor (snap disc) has tripped  Convection blower may need cleaning	Turn power off to appliance and manually reset snap disc then turn power back on Clean convection blower if needed
VACUUM SW ERROR (SW = Switch)	Vacuum switch is bad  Vacuum hose is plugged/disconnected	Check connections. Bypass vacuum with jumper wire, if runs, switch is bad. Replace switch Check vacuum hose
COMB BLOWER JAMMED	Combustion blower is blocked/jammed	Remove blockage Replace blower if necessary Must unplug appliance to clear error
AUGER JAMMED	Auger jammed, feed motor bad	Pull the feed system and inspect Clear jam and Press Retry
MISSED IGNITION	Igniter bad or poor harness connection Out of fuel or fuel is bridging in hopper Faulty firepot thermocouple connection has shorted.	Check connections, if OK replace igniter Break up bridging pellets. Refill hopper Replace the thermocouple Press Retry
MIN FIREPOT TEMP	Out of fuel	Refill hopper Add handful of pellets to firepot to prime it Press Retry
MAX DROP TUBE TEMP	Appliance in over-heat condition Flame height set too high Components may need cleaning	Confirm setting matches burning fuel Adjust flame height Clean the firebox, heat exchanger, convection blower, firepot and ash pan
CONV BLOWER JAMMED	Convection blower blocked/jammed	Remove blockage Replace blower if necessary Must unplug appliance to clear error
CHECK ASHPAN	Auto-clean jammed  Auto-clean switch is bad Linkage has become disconnected	If ashpan is empty, check for a jam. Use a screw driver and firmly push in the firepot floor holes and flex spring and push toward home to release jam Replace switch Reconnect linkage
SCREEN GOES BLANK	Static discharge or nearby lightning or Electric fast transients at the input mains	Wait 25 seconds and press any key to refresh the screen.
	Hopper lid not closed all the way Switch is out of adjustment (auger will not function)	Close the lid. If that didn't work replace the switch Adjust or replace switch
	Firebox door is not latched properly	Adjust or replace door switch
	Out of fuel	Check the fuel level, if OK the switch may be out, replace switch

# 5 Service Parts Replacement

## A. Blower Replacement

### 1. Combustion (Exhaust) Blower Replacement

- a. Remove panel set and disconnect flue.
- b. Pull appliance out onto the hearth.
- c. Remove right access panel and then slide out right side panel of appliance, held in place with 2 screws, to expose the exhaust blower.
- d. Disconnect the white and blue wires from the blower.
- e. Remove blower mounting screws (not housing bolts), **Figure 17.2**, from blower housing and remove blower. The replacement blower is shipped with a housing. If you do not need the housing, discard it. If you do need to replace the housing you will also need to replace the gasket. See Service Parts starting on **page 24** for the part number.
- f. Re-install in reverse order.

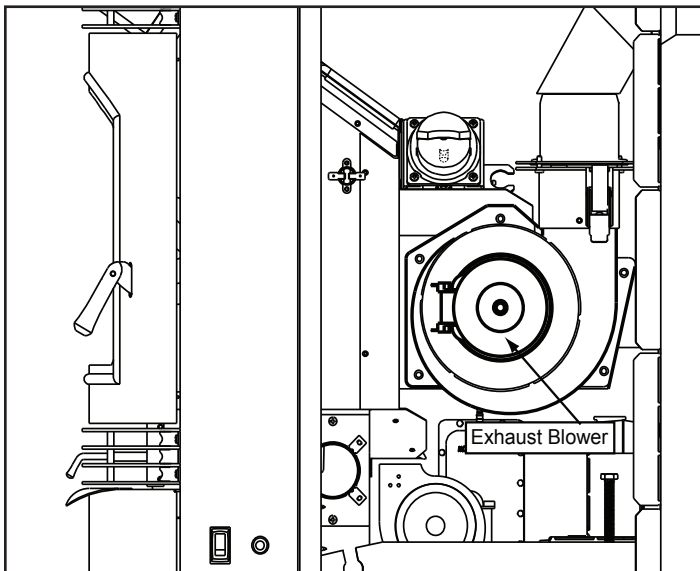

Figure 17.1

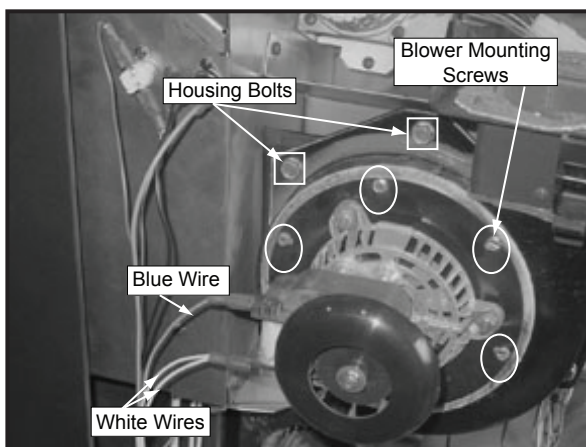

Figure 17.2

### 2. Convection Blower Replacement

- a. The blower is located at the bottom rear of the insert. If an outside air kit is also installed, you will first need to remove the outside air flange by removing the 2 screws using a Phillips head screwdriver. You do not need to remove the flex pipe from the flange.
- b. Remove panel set and disconnect flue.
- c. Pull appliance out onto the hearth.
- d. Remove left access panel and then slide out left side panel of appliance to expose the convection blower. Loosen wing nut on the vacuum switch and remove vacuum switch to allow room to remove the blower.
- e. Disconnect the wires from the blower. The wires coming from the wiring harness are purple & white and the wires from the blower are black.
- f. The blower is held in place with a magnet. A wing nut and plate are installed at the factory for shipping purposes only. This can be removed once the appliance is installed. Lift up blower from the magnet and remove.
- g. Re-install in reverse order.

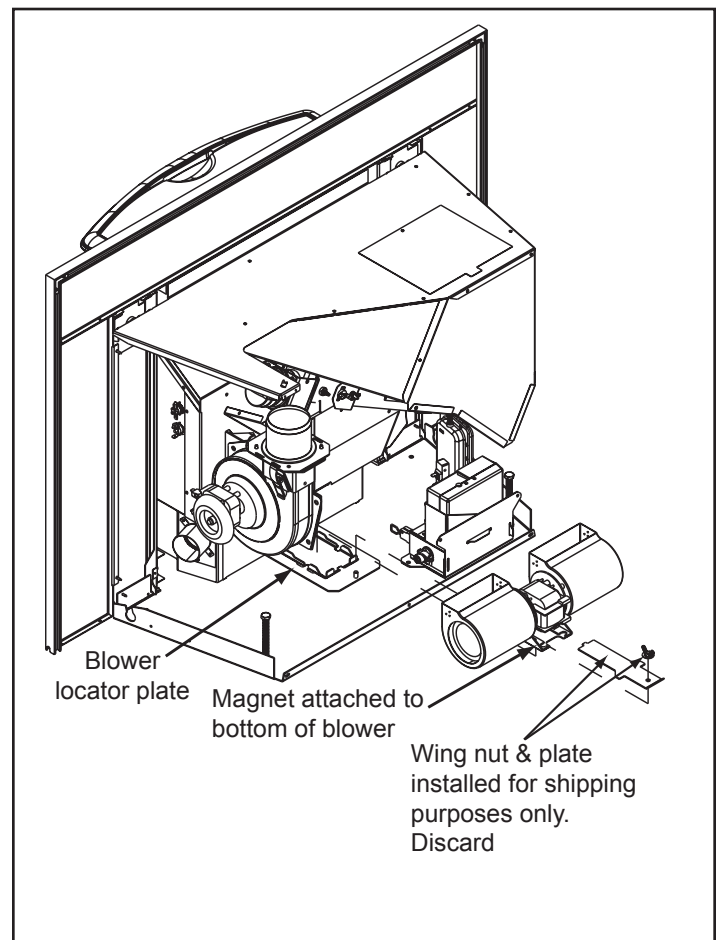

Figure 17.3



## B. Baffle & Brick Replacement

1. Follow proper shutdown procedures in Section 10.
2. The top baffle has a hook on the bottom left side that rests on the top lip of the cast brick. There is a tab on the bottom right side that hooks into the side bracket. Remove the top baffle by first pulling the baffle forward until back edge drops down. Then slide baffle back until the front edge clears the shelf that it had been resting on. **Figure 18.1.**
3. The top baffle must be removed before you can remove the right and left brick. Remove the right brick by holding top lip of brick and lifting up, then push outside edge back. Slide brick to the right until it is flush with the firebox. Rotate the inside edge of the brick forward and remove brick. Repeat for left brick. **Figure 18.2.**

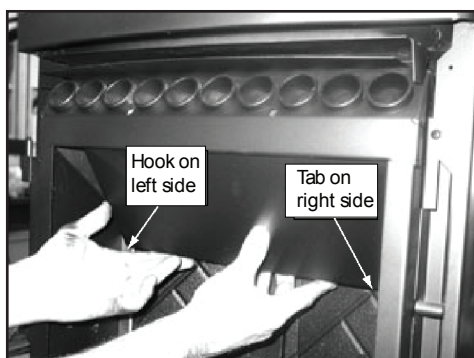

Figure 18.1

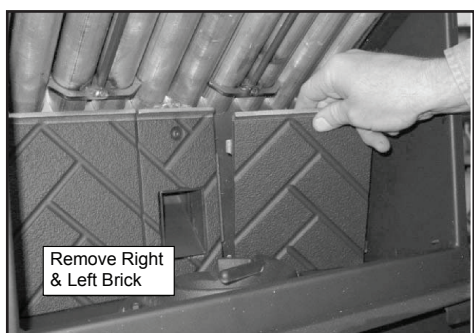

Figure 18.2

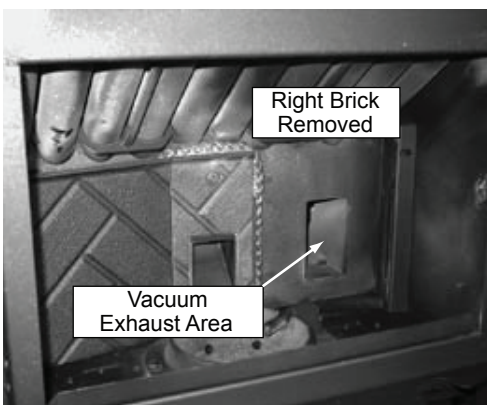

Figure 18.3

## C. Re-installing Baffle & Brick Set

1. Place right brick in behind the right bracket, and then slide to the left so the tabs are behind the center brick. **Figure 18.4.**
2. The brick will be flush against the back wall and notches exposed in the side bracket. **Figure 18.5.**
3. Lift slightly and pull the right edge of the brick forward until it stops and then drops down into both top and bottom notches of right bracket and locks into place. **Figures 19.1 and 19.2.**
4. Repeat for left brick.
5. Insert baffle into top front inside the firebox and pull forward. Then raise up the bottom end and insert baffle tab into slot on the top of the right bracket to lock into place. **Figure 19.3.** Place the left side hook at the bottom of the baffle over the top edge of brick for stability. **Figure 19.4.**
6. The baffle does not completely cover the top of the firebox. There is an opening on the left as shown in **Figure 19.5.**

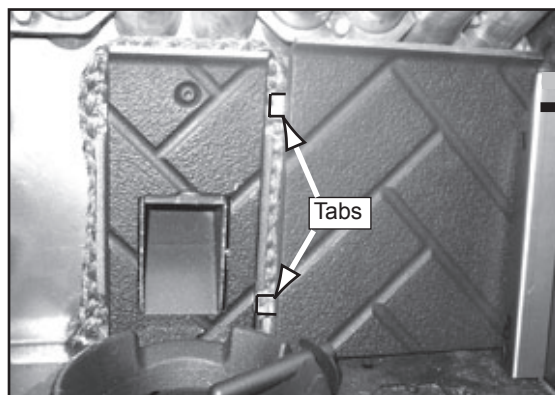

Figure 18.4

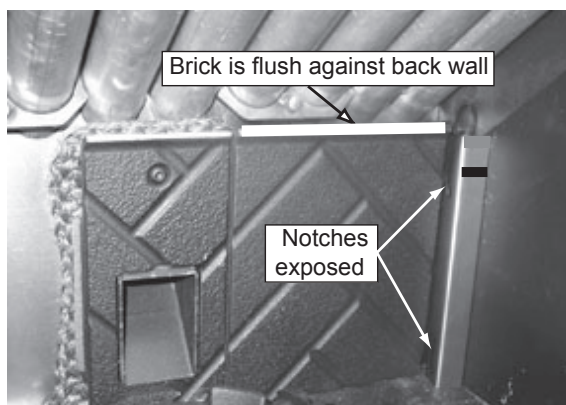

Figure 18.5



Re-installing Baffle & Brick Set (Cont'd)

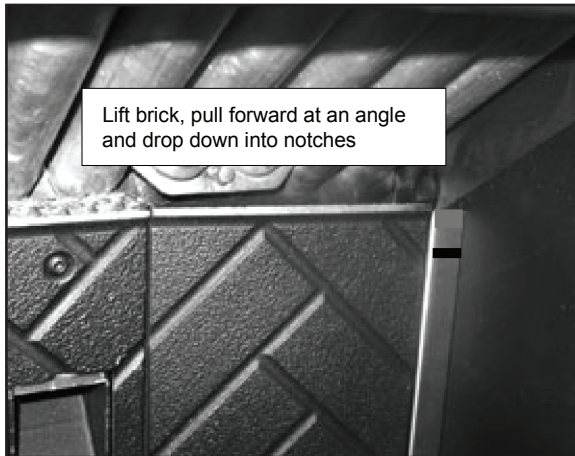

Figure 19.1

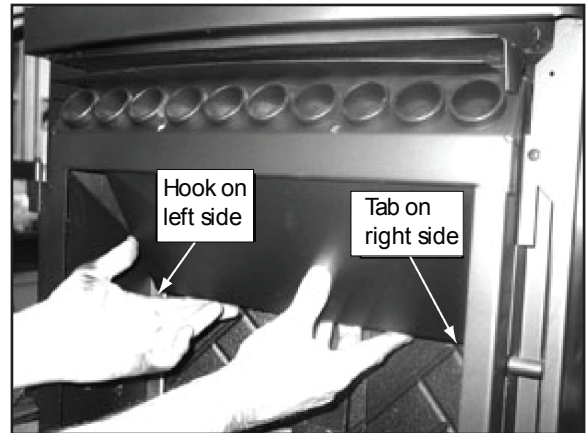

Figure 19.4



Figure 19.2

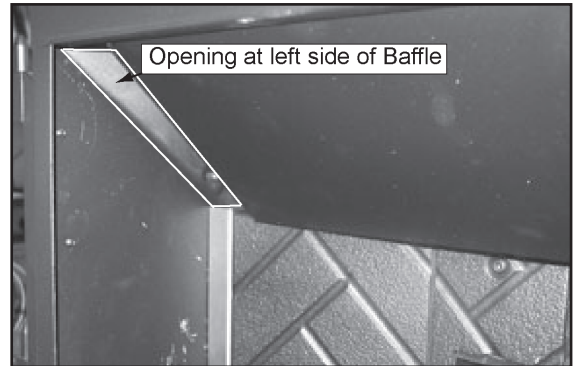

Figure 19.5

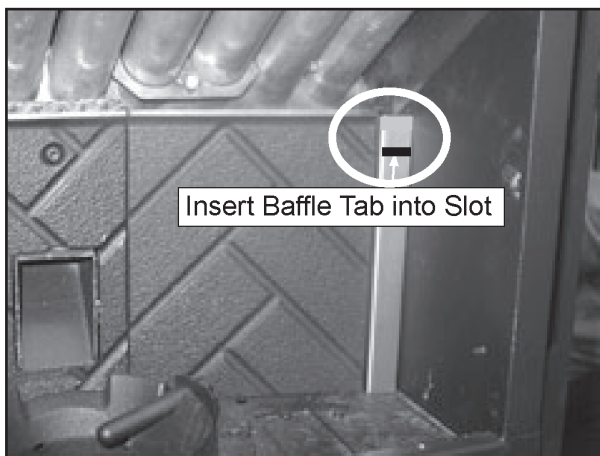

Figure 19.3

### D. Igniter Replacement

- Shut down the appliance by turning down the thermostat and let the appliance completely cool down. After the appliance has cooled down, unplug it and remove the ash drawer.
- The wire leads to the igniter are connected to the wire harness with 1/4 inch (6mm) male / female spade connectors. These wires will pull forward approximately 4 to 5 inches (102mm to 127mm) through the grommet at the back of the ash drawer chamber. Disconnect the spade connections and remove the igniter from the chamber. Loosen the thumb screw and slide igniter out.
- Install new igniter into the chamber and tighten the thumb screw. Re-connect the wires to the 2 leads with the spade connectors.
- Push excess wire leads back through the grommet, one wire at a time, to take-up the 4 to 5 inches (102mm to 107mm) previously pulled out. This will keep the wires out of the way of the ash drawer. Double check that the igniter wires are clear of any movement, i.e. ash drawer, firepot cleaning rod, cleaning slide plates, etc.
- Re-install the ash drawer and then re-install the side panel and re-connect the power.

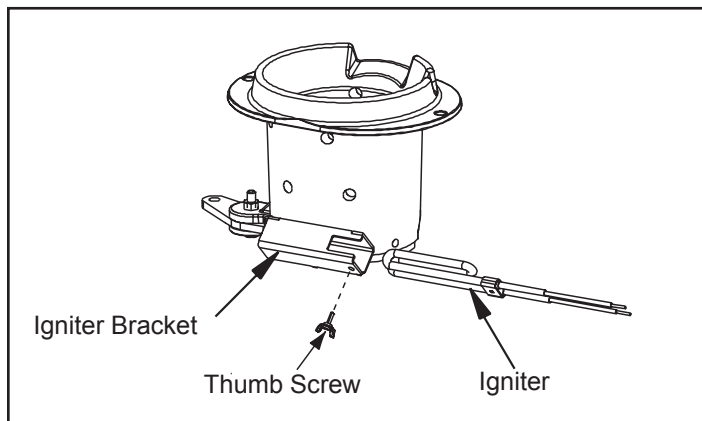

Figure 20.1

### E. Glass Replacement

- The door handle and face must be removed first. Follow instructions found on **page 18 of the installation manual**.
- Remove door from the insert and lay on a flat surface face down.
- Using a screwdriver, tap the bottom of the rope retainer rod to push it up out of the hole. The top end of the rod will slide up. Swing the rod toward you from the bottom and remove the rod. Repeat for other side.
- Remove old glass and replace with new glass.
- Slide the retainer rod into the top hole first, and then line up the bottom crimped end with the hole in the door. The crimped end must be parallel with the glass in order to insert it into place. **Figure 20.2.**

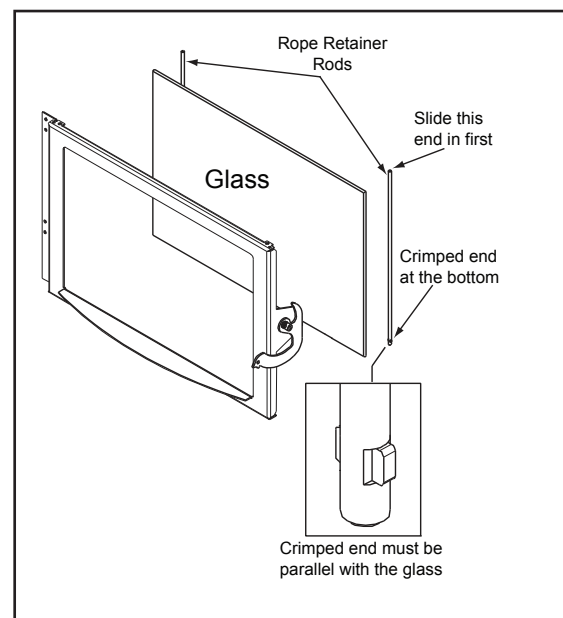

Figure 20.2

### WARNING



- Glass is 5mm thick high temperature heat-resistant ceramic glass.
- DO NOT REPLACE with any other material.
- Alternate material may shatter and cause injury.

# 6 Reference Materials

## A. Component Functions



When describing the location of a component, it is always **AS YOU FACE THE FRONT OF THE APPLIANCE**.

### 1. Control Box

- a. The control box is located on lower left side of appliance, on top of the junction box.
- b. There is a light located inside of the control box. The internal light will turn green when the appliance has reached a temperature of 200°F (93°C) in the firepot. and will turn red when it reaches 600°F (315°C).
- c. There is also an internal blue light located in the upper left corner of the control box. When you plug in the appliance the blue light will automatically start blinking 6 blinks every 10 seconds for 60 seconds and then will stop.

#### NOTE:

Do **NOT** open the control box. This will void the warranty. If you need to plug in or remove the control box you must first **unplug the appliance**.

### 2. Convection Blower

The convection blower is mounted at the bottom rear of the appliance. There are 2 impellers, one on each side of the motor. The convection blower pushes heated air through the heat exchange system into the room.

### 3. Exhaust Blower

The exhaust blower is mounted on the right side of the appliance behind the right side panel. The exhaust blower is designed to pull the exhaust from the appliance and push it out through the venting system.

### 4. Feed System

The feed system is located behind the firebox and can be removed as an entire assembly. The assembly includes the feed motor, mounting bracket, bearing and feed spring (auger). The hollow feed spring (auger) pulls pellets up the feed tube from the hopper area and drops them down the feed chute into the firepot.

### 5. Firepot

The firepot is made of high quality ductile iron and has a cleaning pull-out rod. The floor of the firepot opens for cleaning when you pull out the rod. Be sure that the floor returns to a completely closed position or your appliance will not operate properly.

### 6. Fuse

The fuse is located on the side of the junction box above the red call light. The fuse will blow should a short occur and shut off power to the appliance.

### 7. Heat Exchangers

The heat exchangers transfer heat from the exhaust system into convection air. There are 2 clean out rods located under the heat exchangers.

### 8. Heat Output Switch

The heat output switch is located on the lower right side of firebox, in front of the right access panel and to the left of the reset button. The function of the heat output switch is to regulate the burn rates; low, medium and high settings.

### 9. Hopper Switch

The hopper switch is located in the upper right hand corner of the hopper. This switch is designed to shut down the feed motor whenever the hopper lid is opened.

### 10. Igniter

The igniter is mounted on the base of the firepot. Combustion air travels over the red hot igniter creating super heated air that ignites the pellets.

### 11. Junction Box And Wiring Harness

The junction box is located on the lower left side of the appliance, behind the left front access panel. The junction box and wiring harness are replaced as one component.

### 12. Power Supply

The power outlet is located on the lower left side of the appliance on the front of the junction box. Check the wall receptacle for 120 volt, 60 Hz (standard current). Make sure the outlet is grounded and has the correct polarity. A good surge protector is recommended. When operating with a generator you need a least 600 watts of power, or with an inverter at least 800 watts of power available for the appliance during the start cycle.

### 13. Red Call Light

The red call light is on the side of the junction box underneath the fuse. The function of the red call light is to indicate that the thermostat is calling for heat.

### 14. Reset Button

The reset button is located on the lower right side of firebox in front of the right access panel and to the right of the heat output control switch. The function of the switch is to momentarily open the thermostat circuit, which restarts the system.

### 15. Thermocouple

The thermocouple is located on top of the firepot inside the thermocouple cover (ceramic protection tube). The thermocouple sends a millivolt signal to the control box indicating the preset temperatures of the green and red lights have been obtained.

### 16. Thermostat

The appliance is designed to run on a 12 volt AC thermostat. The heat anticipator, if present, should be set on the lowest setting available.

**17. Snap Disc #1 (Convection Blower) 110°F**

Snap disc #1 is located on the right side of the firebox. There are 2 purple wires connected to it. This snap disc turns the convection blower on and off as needed. Power is always present at snap disc #1.

**18. Snap Disc #2 (Fuel Delivery Interrupt) 250°F**

Snap disc #2 is located on the back side of the feed drop tube. (see Figure 23.2 on page 23). There is 1 orange wire and 1 black wire connected to it. This snap disc will turn off the feed system, which will turn off the appliance if an overfire condition should occur or if the convection blower should fail to operate. If this occurs the snap disc will automatically reset itself.

**19. Snap Disc #3 (Burn Back Protector) 250°F**

Snap disc #3 is mounted on the back of the auger tube in the center of the appliance and has a reset button. To access it remove the right side panel. If the fire tries to burn back into the feed system or push exhaust up the feed tube, this snap disc will shut the entire system off. This disc must be manually reset.

**20. Vacuum Switch**

The vacuum switch is located on the lower left side of the appliance behind left access panel. This switch turns the feed system on when vacuum is present in the firebox. The vacuum switch is a safety device to shut off the feed motor if the exhaust or the heat exchanger system is dirty or plugged or if the firebox door is open.

**21. Wiring Harness**

See Figure 22.1 below

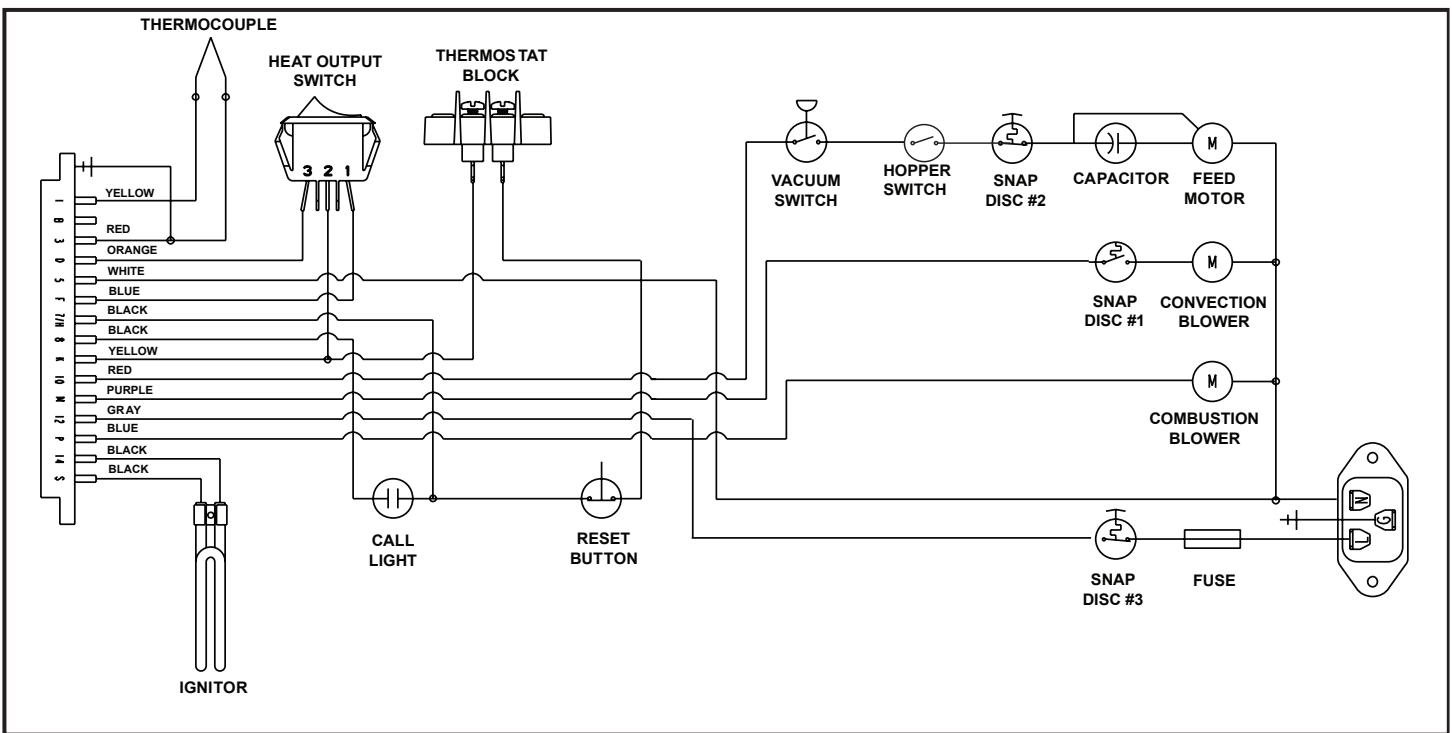
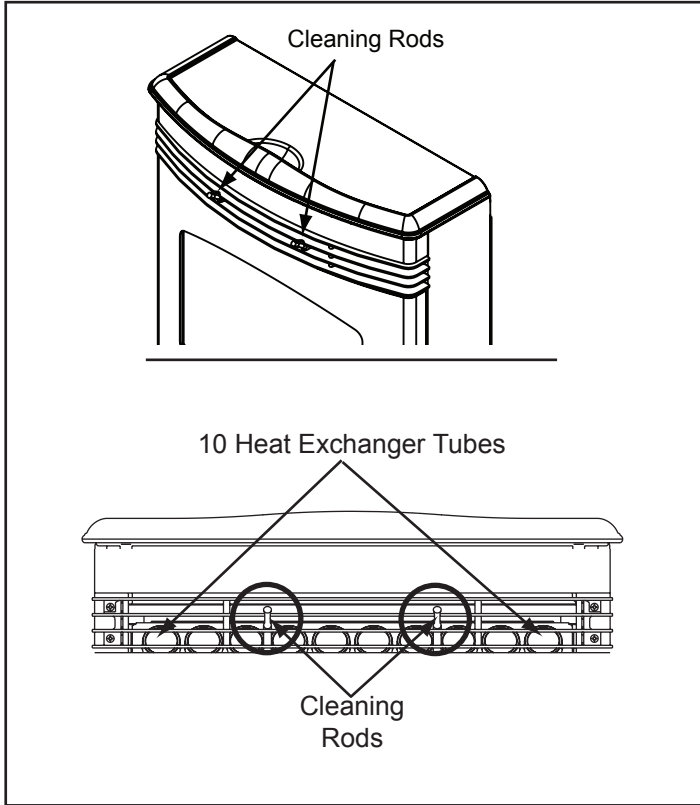
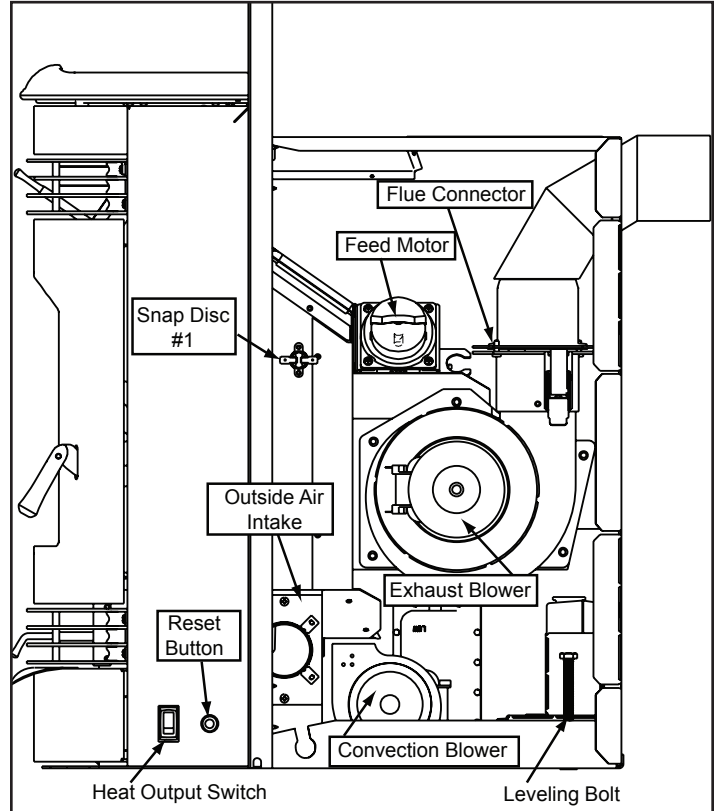

Figure 22.1

**B. Component Locations**



**Figure 23.1 - Cleaning Rods & Heat Exchanger Tubes**



**Figure 23.3 - Component Locations - Right Side**

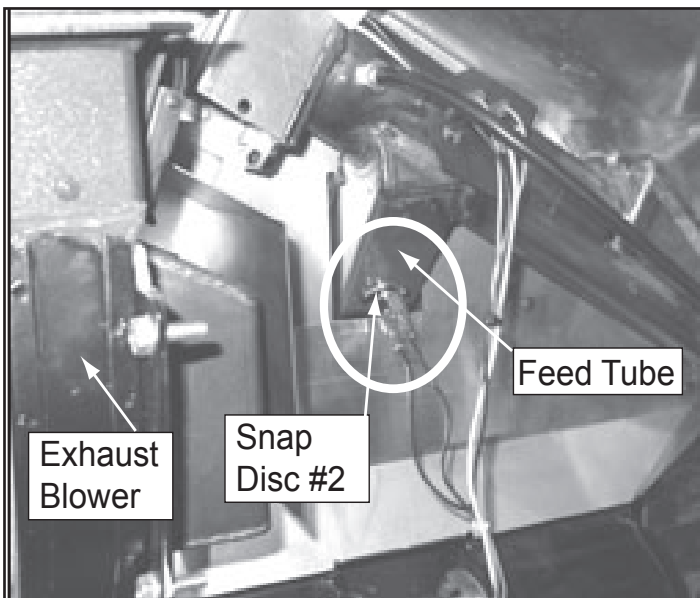

**Figure 23.2 - Snap Disc #2 located on back of Feed Tube.**

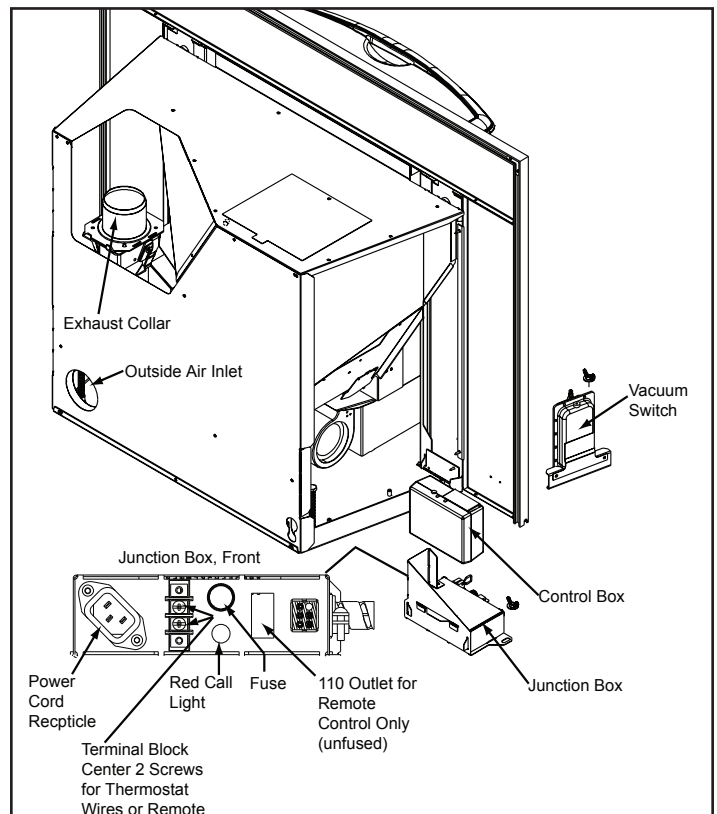

**Figure 23.4 - Component Locations - Left Side**



C. Exploded Drawings & Service Parts

**QUADRA-FIRE**® Service Parts

Pellet Insert

**SANTAFEI-MBK**

Beginning Manufacturing Date: Dec. 2009  
Ending Manufacturing Date: Active

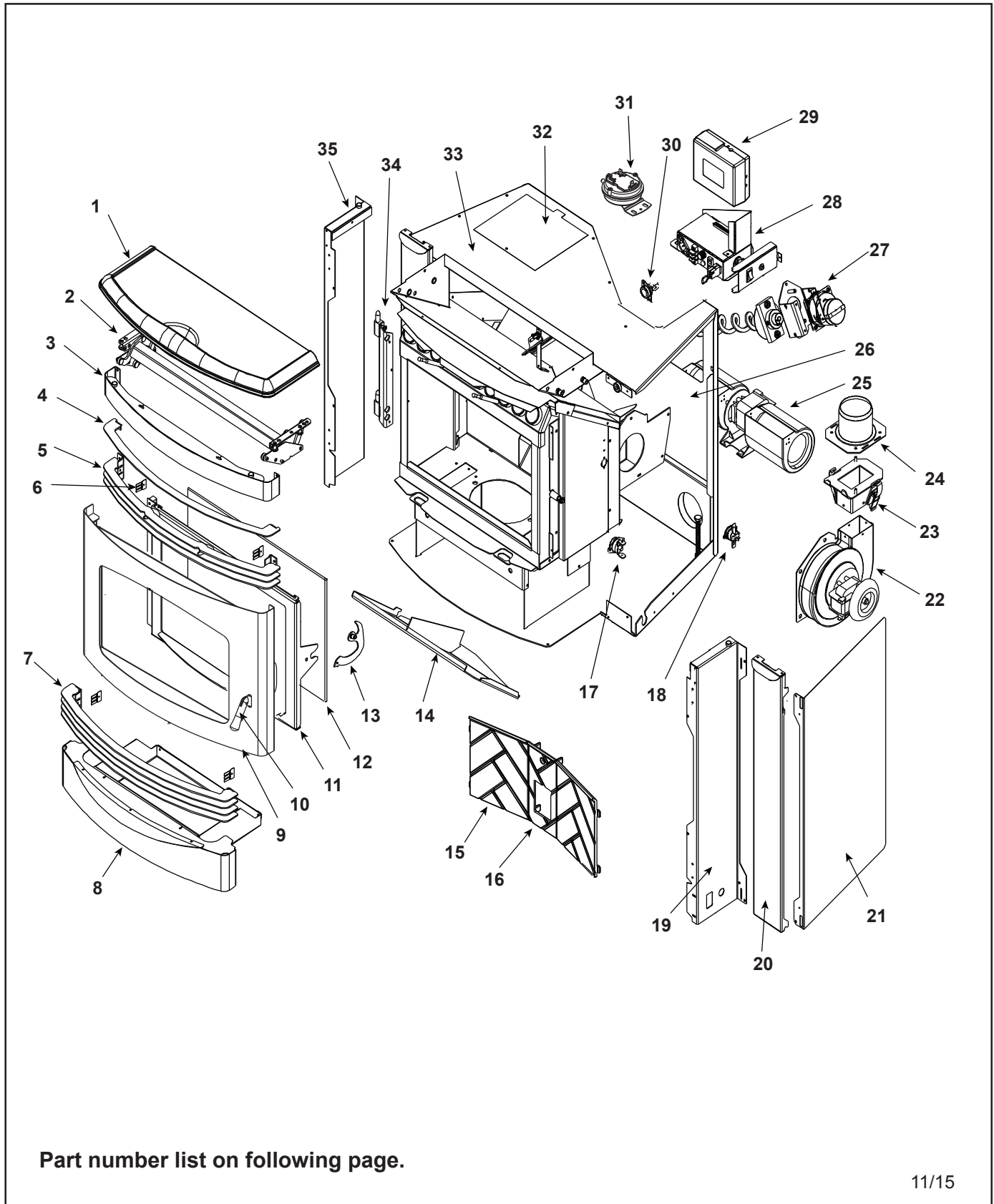

Part number list on following page.

Beginning Manufacturing Date: Dec. 2009  
Ending Manufacturing Date: Active

IMPORTANT: THIS IS DATED INFORMATION. Parts must be ordered from a dealer or distributor. **Hearth and Home Technologies does not sell directly to consumers.** Provide model number and serial number when requesting service parts from your dealer or distributor.



**Stocked  
at Depot**

ITEM	DESCRIPTION	COMMENTS	PART NUMBER	
1	Top, Hopper Lid		7019-227	
	Bumper, Rubber	Pkg of 12	SRV224-0340/12	Y
2	Top Hinge Assembly		7019-023	
3	Top Face Assembly		7019-047	
	Louver Grille Assembly - Complete Set	Black Nickel	GRL-SFI-NB	
		<b>No longer available</b>	GRL-SFI-GD	
		Nickel	GRL-SFI-NL	
4	Grill Bar (Scraper) - 1 Pc	Black	7019-119	
		Black Nickel	7019-191	
		Gold	7019-161	
		Nickel	7019-164	
5	Upper Grill Assembly - 3 Pc	Black	7019-007	
		Black Nickel	7019-189	
		Gold	7019-159	
		Nickel	7019-162	
6	Grill Bracket Cover		7019-199	
7	Lower Grill Assembly - 4 Pc	Black	7019-008	
		Black Nickel	7019-190	
		Gold	7019-160	
		Nickel	7019-163	
8	Ash Draw Assembly		7019-006	
9	Face Assembly w/Door		SRV7019-045	
	Face Skin Assembly		SRV7019-046	
10	Door Handle Assembly		SRV7019-037	
	Door Handle Black Nickel		7019-174	
11	Door Assembly with Glass		7019-013	
12	Glass Assembly - 17-1/4 in. W x 11-5/8 in H		7001-038	Y
13	Door Latch Assembly		7019-015	
	Pin 3/16 X 1/2		7000-229	
	Gasket, Tadpole, 3/8 - Field Cut to Size	10 Ft	842-5130	Y
	Hinge, Female		450-2910	
	Retainer, Rope		7001-192	Y
	Tape, 1/2" X 1/16 - Field Cut to Size	10 Ft	240-0290/10	Y
14	Baffle Assembly		7001-034	Y
15	Brick, Left / Right, Cast		414-0270	
16	Brick, Center, Cast		414-0260	
17	Snap Disc Manual Reset # 3		SRV230-1290	Y
	Bracket, Snap Disc#3		7001-221	

IMPORTANT: THIS IS DATED INFORMATION. Parts must be ordered from a dealer or distributor. **Hearth and Home Technologies does not sell directly to consumers.** Provide model number and serial number when requesting service parts from your dealer or distributor.



Stocked at Depot

ITEM	DESCRIPTION	COMMENTS	PART NUMBER	
18	Snap Disc, 110-20 # 1		SRV230-1220	Y
19	Face Right		SRV7019-116	
20	Access Panel Assembly		7019-025	
21	Outer Skin Left / Right Side	Interchangeable	7019-100	
22	Blower, Exhaust Combustion		812-4400	Y
	Gasket, Exhaust Combustion Blower (between...)	...Motor & Housing	812-4710	Y
		...Housing & Stove	240-0812	Y
23	Exhaust Transition Assembly		414-5100	
	Flue Adapter Flange Gasket		7036-180	
	Latch, Draw		229-0230	
24	Flue Collar Assembly		7019-031	
25	Blower, Convection		812-4900	Y
	Blower Magnet	Pkg of 10	7019-188/10	
26	Outer Skin Back		SRV7019-101	

**#27 Feed Assembly**

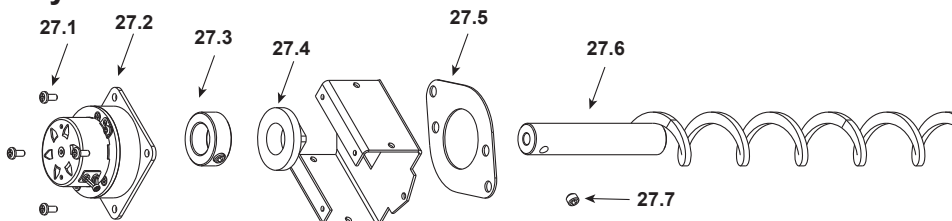

27	Feed Assembly		812-4760	Y
27.1	Screw 8-32 x 3/8	Pkg of 40	225-0500/40	Y
27.2	Feed Motor		812-4421	Y
27.3	Collar, Set, 7/8		229-0520	
27.4	Bearing, Feed System, Nylon		SRV7000-598	Y
27.5	Gasket, Feed Motor		240-0731	Y
27.6	Feed Spring Assembly (Only)		SRV7001-046	Y
27.7	Screw, 5/16-18 x 1/4	Pkg of 25	225-0550/25	Y
28	Wire Harness/Junction Box		7019-166	Y
29	Control Board 3 Speed		SRV7000-704	Y
	Wing Thumb Screw 8-32 X 1/2	Pkg of 24	7000-223/24	Y
30	Snap Disc # 2		SRV7000-268	Y
	Bracket, Snap Disc		7005-253	
31	Vacuum Switch		SRV7000-531	Y
32	Plate, Cover, Outer Can		480-1300	
33	Outer Skin, Top		SRV7019-106	

Beginning Manufacturing Date: Dec. 2009  
Ending Manufacturing Date: Active

IMPORTANT: THIS IS DATED INFORMATION. Parts must be ordered from a dealer or distributor. **Hearth and Home Technologies does not sell directly to consumers.** Provide model number and serial number when requesting service parts from your dealer or distributor.



**Stocked at Depot**

ITEM	DESCRIPTION	COMMENTS	PART NUMBER
34	Door Hinge Assembly		SRV7019-014
	Hinge, Door, Male		450-2810
35	Face Left		SRV7019-220

**#36 Firepot Assembly**

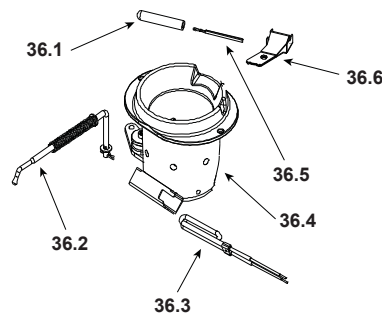

36.1	Thermocouple Cover	Pkg of 10	812-4920	Y
36.2	Pull Rod Assembly		7019-009	
	Pull Rod Black Nickel		7019-172	
	Spring, Firepot		200-2050	
36.3	Heating Element Assembly 18" (Loop Igniter)	Pkg of 10	SRV7000-462/10	Y
36.4	Firepot Assembly		SRV414-5200	Y
	Bolt, Firepot, 1-1/4" Long	Pkg of 25	225-0120/25	Y
	Bushing, Firepot		410-8320	Y
	Floor, Firepot		414-0290	Y
	Gasket, Firepot		240-0930	Y
36.5	Thermocouple		812-4470	Y
36.6	Thermocouple Clamp		SRV7001-203	Y
	Component Pack		SRV7019-042	
	Cleanout Tool		414-1140	Y
	Harness, Thermostat Wire		230-0810	
	Power Cord		812-1180	Y
	Deflector, Bottom Airwash		413-0680	
	Feed Adjustment Plate		SRV7019-110	
	Gasket, Flue Adapter		240-0850	Y
	Hose, Vacuum, 5/32 Id - Field Cut to Size	3 Ft	SRV240-0450	Y
	Hopper Switch Assembly		SRV7019-053	Y

Beginning Manufacturing Date: Dec. 2009  
Ending Manufacturing Date: Active

IMPORTANT: THIS IS DATED INFORMATION. Parts must be ordered from a dealer or distributor. **Hearth and Home Technologies does not sell directly to consumers.** Provide model number and serial number when requesting service parts from your dealer or distributor.



Stocked  
at Depot

ITEM	DESCRIPTION	COMMENTS	PART NUMBER	
	Hopper Switch Magnet Bracket		SRV7019-217	Y
	Magnetic Switch		7000-375	Y
	Magnet Round		SRV7000-140	Y
	Plate, Ash Cleanout		7001-186	
	Wire Harness Hopper Switch		SRV414-1220	Y









# QUADRA-FIRE®

NOTHING BURNS LIKE A QUAD

## CONTACT INFORMATION

Hearth & Home Technologies  
1445 North Highway  
Colville, WA 99114  
Division of HNI INDUSTRIES

Please contact your Quadra-Fire dealer with any questions or concerns.  
For the number of your nearest Quadra-Fire dealer  
log onto [www.quadrafire.com](http://www.quadrafire.com)

### CAUTION

#### DO NOT DISCARD THIS MANUAL



- Important operating and maintenance instructions included.
- Read, understand and follow these instructions for safe installation and operation.
- Leave this manual with party responsible for use and operation.

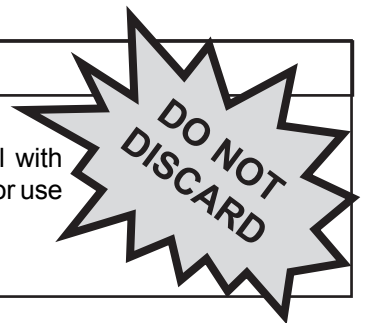

**We recommend that you record the following pertinent information for your heating appliance.**

Date purchased/installed: \_\_\_\_\_

Serial Number: \_\_\_\_\_ Location on appliance: \_\_\_\_\_

Dealership purchased from: \_\_\_\_\_ Dealer phone: \_\_\_\_\_

Notes: \_\_\_\_\_

\_\_\_\_\_

\_\_\_\_\_

This product may be covered by one or more of the following patents: (United States) 5341794, 5263471, 6688302, 7216645, 7047962 or other U.S. and foreign patents pending.