

# Owner's Manual

## Care and Operation

**INSTALLER:** Leave this manual with party responsible for use and operation.

**OWNER:** Retain this manual for future reference.

Contact your dealer with questions regarding installation, operation or service.

**NOTICE: DO NOT** discard this manual!

# QUADRA-FIRE®

**Model:**

**HUDBAY-FS**

Tested and  
Listed by  Portland  
Oregon USA  
OMNI-Test Laboratories, Inc.

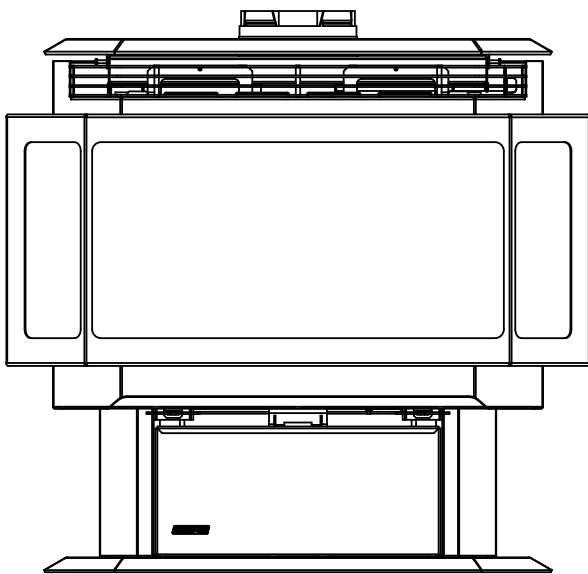

This appliance may be installed as an OEM installation in manufactured home (USA only) or mobile home and must be installed in accordance with the manufacturer's instructions and the manufactured home construction and safety standard, *Title 24 CFR, Part 3280* or *Standard for Installation in Mobile Homes, CAN/CSA Z240MH*, in Canada.

*This appliance is only for use with the type(s) of gas indicated on the rating plate.*

### ⚠ WARNING:

#### FIRE OR EXPLOSION HAZARD

Failure to follow safety warnings exactly could result in serious injury, death, or property damage.

- Do not store or use gasoline or other flammable vapors and liquids in the vicinity of this or any other appliance.
- **WHAT TO DO IF YOU SMELL GAS**
  - Do not try to light any appliance.
  - Do not touch any electrical switch; do not use any phone in your building.
  - Leave the building immediately.
  - Immediately call your gas supplier from a neighbor's phone. Follow the gas supplier's instructions.
  - If you cannot reach your gas supplier, call the fire department.
- Installation and service must be performed by a qualified installer, service agency or the gas supplier.

# ⚠ DANGER



**HOT GLASS WILL CAUSE BURNS.**

**DO NOT TOUCH GLASS UNTIL COOLED.**

**NEVER ALLOW CHILDREN TO TOUCH GLASS.**

A barrier designed to reduce the risk of burns from the hot viewing glass is provided with this appliance and shall be installed for the protection of the children and other at-risk individuals.

In the Commonwealth of Massachusetts:

- Installation must be performed by a licensed plumber or gas fitter.

See Table of Contents for additional Commonwealth of Massachusetts requirements.

# Congratulations

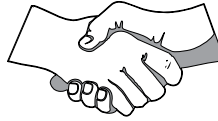

## and Welcome to the Quadra-Fire Family!

Hearth & Home Technologies welcomes you to our tradition of excellence! In choosing a Quadra-Fire appliance, you have our assurance of commitment to quality, durability, and performance.

This commitment begins with our research of the market, including 'Voice of the Customer' contacts, ensuring we make products that will satisfy your needs. Our Research and Development facility then employs the world's most advanced technology to achieve the optimum operation of our stoves, inserts and fireplaces. And yet we are old-fashioned when it comes to craftsmanship.

Each appliance is meticulously fabricated and gold and nickel surfaces are hand-finished for lasting beauty and enjoyment. Our pledge to quality is completed as each model undergoes a quality control inspection. From design, to fabrication, to shipping: Our guarantee of quality is more than a word, it's Quadra-Fire tradition, and we proudly back this tradition with a Limited Lifetime Warranty.

We wish you and your family many years of enjoyment in the warmth and comfort of your hearth appliance. Thank you for choosing Quadra-Fire.

### SAMPLE OF SERIAL NUMBER / SAFETY LABEL LOCATION: ON FRONT PANEL OF APPLIANCE

Test Lab & Report No.

Model Name

Serial Number

**Test Lab & Report No.**

Approved for Canada and USA:  
ANSI Z21.88-2014/CSA 2.33-2014 Vented Gas Fireplace Heaters, CAN/CGA 2.17-M91 (R2009) "Gas Fired Appliances for use at High Altitudes."

This appliance is manufactured for operation with Natural Gas.

For conversion to propane use Manufacturer's conversion kit and instructions supplied with the appliance. This appliance may be installed in a bedroom or bed sitting room; in Canada remote thermostat installation is required.

This vented gas fireplace heater is not for use with air filters.

This appliance must be installed in accordance with the current Standard CAN/CSA Z240 MH, Mobile Housing, or with Manufactured Home Construction and Safety Standard, Title 24 CFR, Part 3280, or when such standard is not applicable, ANSI/NCSB/CSA Z225.1/NFPA 501A, Manufactured Home Installation Standard.

**WARNING:** do not operate the appliance until all sections have been assembled and installed in accordance with the manufacturer's instructions.

**WARNING:** improper installation, adjustment, alteration, service or maintenance can cause injury or property damage. Refer to the owner's information manual provided with this appliance. For assistance or additional information consult a qualified installer, service agency or the gas supplier.

Warning: operation of this appliance when not connected to a properly installed and maintained venting system can result in carbon monoxide (CO) poisoning and possible death.

**WARNING:** operation of this appliance when not connected to a properly installed and maintained venting system or tampering with the blocked vent shut-off system can result in carbon monoxide (CO) poisoning and possible death. Caution: hot while in operation. Do not touch. Severe burns may result. Keep children, clothing, furniture, gasoline and other liquids having flammable vapors away.

For use only with barrier Part No. 7055-020

Caution: do not operate this appliance with glass removed, cracked or broken. Replacement of the panel(s) should be done by a licensed or qualified person.

**DO NOT REMOVE THIS LABEL / NE PAS ENLEVER L'ÉTIQUETTE Made in U.S.A. / Fait Aux États-Unis**

**Model (Modèle): Hudson Bay FS**

**Serial No. 008**

**VENTED GAS FIREPLACE HEATER  
NOT FOR USE WITH SOLID FUEL  
FOURNAISE AU GAZ AVEC VENTILATION  
NE PAS UTILISER AVEC LE COMBUSTIBLE SOLIDE**

APPROUVÉ POUR LE CANADA ET LES ÉTATS-UNIS:  
ANSI Z21.88-2014/CSA 2.33-2014 Fournaises au Gaz avec Ventilation, CAN/CGA 2.17-M91 (R2009) "Gas Fired Appliances for use at High Altitudes".

Cet appareil est manufacturé pour l'opération avec le Gaz Naturel.

Pour une conversion au gaz propane les pièces du Manufacturier Cet appareil peut être utilisé dans une chambre à coucher ou salle de séjour; au Canada, l'installation d'un thermostat à distance est exigée.

Cet appareil de chauffage au gaz n'est pas pour l'usage avec des filtres d'air. Installer l'appareil selon la norme CAN/CSA Z240, Série MM, Maisons mobiles, ou la norme 24 CFR Part 3280, Manufactured Home Construction and Safety Standard. Si ces normes ne sont pas pertinentes, utilisez la norme ANSI/NCSB/CSA Z225.1/NFPA 501A, Manufactured Home Installations Standard.

**AVERTISSEMENT:** ne pas utiliser l'appareil tant que toutes les sections n'ont pas été assemblées et installées selon les instructions du fabricant.

**AVERTISSEMENT:** une installation, un ajustement, une altération, un service ou un entretien incorrects peuvent causer des dommages matériels. Référez-vous au manuel d'information fourni avec cet appareil. Pour assistance ou des informations supplémentaires consultez un installateur qualifié, une agence de service ou un fournisseur de gaz.

Advertissement: l'opération de cet appareil lorsqu'il n'est pas connecté à un système de ventilation correctement installé et maintenu peut résulter à un empoisonnement d'oxyde de carbone ou même de mort possible.

Advertissement: l'opération de cet appareil lorsqu'il n'est pas connecté à un système de ventilation proprement installé ou si le système de fermeture de ventilation a été altéré, cela peut résulter à un empoisonnement d'oxyde de carbone ou même de perte de vie.

Utiliser uniquement avec barrière Référence 7055-020

**AVERTISSEMENT:** chaud lorsqu'il est en opération. Ne touchez pas. Des brûlures sévères peuvent en résulter. Gardez les enfants, les vêtements, les meubles, la gasoline et les autres liquides de vapeur inflammable éloignés.

Attention: cet appareil ne doit pas être opéré si la vitre est brisée, craquée ou enlevée. Le remplacement du panneau doit être fait par une personne licenciée et qualifiée.

**BARCODE LABEL**

**QUADRA-FIRE**

352 Mountain House Road  
Halifax, PA 17032  
www.quadrafire.com

APPROUVÉ POUR LE CANADA ET LES ÉTATS-UNIS:  
ANSI Z21.88-2014 / CSA 2.33-2014 Fournaises au Gaz avec Ventilation, CAN/CGA 2.17-M91 (R2009) "Gas Fired Appliances for use at High Altitudes".

Cet appareil est manufacturé pour l'opération avec le Gaz Naturel.

Pour une conversion au gaz propane les pièces du Manufacturier Cet appareil peut être utilisé dans une chambre à coucher ou salle de séjour; au Canada, l'installation d'un thermostat à distance est exigée.

	Usage Au Gaz Naturel "B-2000"	Usage Au Gaz Propane "B-2000"	For use with Natural Gas "B-2000"	For use with Propane "B-2000"
Puissance Évaluée à "H" (BTU/H)	42,000	40,500	42,000	40,500
Puissance Évaluée à "L" (BTU/H)	28,000	31,000	28,000	31,000
Orifice du Brûleur Principal	125"	076"	125"	076"
Pression Minimum de la Valve (pouces W.C.)	4.5"	11"	4.5"	11"
Pression Maximum de la Valve (pouces W.C.)	7.0"	14"	7.0"	14"
Pression du Collecteur d'Échappement à "H" (pouces W.C.)	3.5"	10"	3.5"	10"

Cet appareil est équipé pour les altitudes de 0-2000' (0-610m) aux États-Unis; et au Canada pour les altitudes de 0-4500' (0-1370m). Pour les altitudes au-dessus de 2000' aux États-Unis, la configuration du ventilateur, son orifice ou les deux peuvent possiblement avoir à être changé. Voyez le manuel du propriétaire pour les informations sur ces changements.

Utilisez le bruleur et le compartiment de contrôle propres. Vérifiez les instructions d'installation et d'opération qui accompagnent cet appareil.

Cet appareil doit être installé selon les codes locaux, s'il y a lieu (et approuvé par dans la République de Massachusetts), sinon suivez les codes THE NATIONAL FUEL GAS ANZI Z223.1; ou les codes Canadian Installation Codes CAN/CGA-B149.

**REMARQUE:** Le conduit gaz doit être installé conformément aux codes de construction locaux. L'installation doit être effectuée par un technicien qualifié et/ou muni d'une licence de manière à respecter les règlements municipaux. (Dans la République de Massachusetts, l'installation doit être effectuée par un plombier ou un installateur d'appareils à gaz agréés.)

Gardez le brûleur et le compartiment de contrôle propres. Vérifiez les instructions d'installation et d'opération qui accompagnent cet appareil.

**ESPACE MINIMUM AUX COMBUSTIBLES**  
Espaces minimum exigés de la construction combustible aux surfaces de l'appareil.

A. Dessus de fourneau au mur latéral	228.6 mm
B. Du côté du poêle au côté du mur	244.5 mm
C. En arrière du fourneau au mur latéral	25.4 mm
D. Du coin arrière du poêle au mur de côté	101.6 mm
E. Hauteur minimum d'étagère du plancher au plafond	132 mm
F. Profondeur maximum de l'étagère	914.4 mm
G. Largeur minimum de l'étagère	1181 mm
H. Dessus de fourneau au plafond	533.4 mm

**CHEMINEE:** Un coussinet non-combustible de cheminée n'est pas exigé. Cependant, le plancher en dessous du poêle doit être droit, à niveau et assez fort pour supporter le poêle sans le hasarder basculer.

Cet appareil doit être utilisé seulement avec le gaz indiqué sur l'étiquette énergétique et peut être installé dans une maison mobile en place permanente dans les endroits permis par les codes locaux. Voyez le manuel du propriétaire pour des détails supplémentaires. Cet appareil ne doit pas être converti avec des autres gaz sans l'utilisation d'un ensemble de conversion certifié.

**VENTILATEUR CIRCULATEUR**  
Évaluation du Ventilateur Électrique: 115 V, 1.5 Amps, 60 Hz, 150 Watts  
Fourme Électrique: 120 Volts, 1.2 Amps, 60 Hz  
Efficacité Thermique Jusqu'à: 84.02% NG (avec ventilateur allumé) 85.71% LP (avec ventilateur allumé)  
P4-1-02 Le Canada layout minimum: 64.03% NG / 65.43% LP

APPROUVÉ POUR LE CANADA AND USA TO:  
ANSI Z21.88-2014 / CSA 2.33-2014 Vented Gas Fireplace Heaters, CAN/CGA 2.17-M91 (R2009) "Gas Fired Appliances for use at High Altitudes".

This appliance is manufactured for operation with Natural Gas.

For conversion to propane use Manufacturer's conversion kit and instructions supplied with the appliance. This appliance may be installed in a bedroom or bed sitting room; in Canada remote thermostat installation is required.

This appliance must be properly connected to a venting system in accordance with the manufacturer's installation instructions.

This appliance must be installed in accordance with local codes, if any (and Commonwealth of Massachusetts approved). In France, follow the National Fuel Gas Code, ANSI Z223.1 or Canadian Installation Codes, CAN/CGA-B149.

**NOTE:** Have the gas supply line installed in accordance with local building codes by a qualified installer approved and/or licensed as required by the locality. In the Commonwealth of Massachusetts, installation must be performed by a licensed plumber or gas fitter.)

Keep burner and control compartment clean. See installation and operating instructions accompanying this appliance.

**MINIMUM CLEARANCES TO COMBUSTIBLES**  
Minimum clearances required from combustible construction for all appliance surfaces.

A. Top of stove to side wall	9 in.
B. Side of stove to side wall	9.5 in.
C. Back of stove to side wall	1 in.
D. LH & RH corner to side wall	4 in.
E. Min. alcove floor to ceiling height	54 in.
F. Maximum alcove depth	36 in.
G. Minimum alcove width	45-12 in.
H. Top of stove to ceiling	21 in.

HEARTH: A non-combustible hearth pad is not required. However, the floor beneath the stove must be stable, level, and strong enough to support the stove without a tipping hazard.

This appliance is only for use with the type of gas indicated on the rating plate and may be installed in an alternate, permanently located, manufactured (mobile) home where not prohibited by local codes. See owner's manual for details. This appliance is not convertible for use with other gases, unless a certified kit is used.

**FAN TYPE VENTED CIRCULATOR**  
Blower Electrical Rating: 115 V, 1.5 Amps, 60 Hz, 150 Watts  
Electrical Supply: 120 Volts, 1.2 Amps, 60 Hz  
Thermal Efficiency up to: 84.02% NG (blower on) 85.71% LP (blower on)  
P4-1-02 Canada Minimum pipe: 64.03% NG / 65.43% LP

7003-951\_R4

2015 2016 2017 JAN FEB MAR APR MAY JUN JUL AUG SEP OCT NOV DEC

Manufactured by/Fabriqué par: Hearth and Home Technologies

MADE IN USA

7003-950

# - TABLE OF CONTENTS -

## Section 1: Listing and Code Approvals

A. Appliance Certifications .....	4
B. Glass Specifications .....	4
C. BTU Specifications .....	4
D. High Altitude Installations .....	4
E. Non-Combustible Materials .....	4
F. Combustible Materials .....	4
G. Electrical Codes.....	4
H. Requirements for the .....	
Commonwealth of Massachusetts.....	5

## Section 2: Getting Started

A. Design & Installation Considerations .....	6
B. Tools and Supplies Needed .....	6
C. Inspect Appliance & Components .....	6

## Section 3: Appliance Location & Clearances

A. Selecting Appliance Location .....	7
B. Clearances to Combustibles.....	7

## Section 4: Termination Locations

A. Vent Termination Minimum Clearances .....	8
--	---

## Section 5: Vent Information

A. Venting Components .....	10
B. Use of Elbows.....	10
C. Measuring Standards .....	10
D. How to Use the Vent Graph.....	11
E. Venting Guidelines .....	11
F. Horizontal Termination .....	12
G. Vertical Termination.....	15

## Section 6: Gas Information

A. Fuel Conversions.....	22
B. Gas Pressures.....	24
C. Gas Connection.....	25

## Section 7: Electrical Information

A. Recommendation for Wire .....	26
B. Connecting to the Appliance.....	26
C. Standing Pilot Ignition System Wiring.....	26

## Section 8: Appliance Setup

A. Remove Shipping Materials.....	28
B. Accessories .....	28
C. Front Door Removal / Installation .....	28
D. Door Crown Installation .....	29
E. Grille Installation .....	29
F. Brick Installation .....	30
G. Positioning the Logs .....	31
H. Mineral Wool.....	32
I. Blower Installation .....	33
J. Damper Adjustment.....	34
K. Shutter Adjustment.....	34
L. Glass Replacement .....	34
M. Safety Barrier Installation .....	35

## Section 9: Operating Instructions

A. Before Lighting Appliance.....	36
B. Controls .....	36
C. Lighting Appliance .....	37
D. After Appliance is Lit.....	38
E. Frequently Asked Questions .....	38

## Section 10: Troubleshooting .....

## Section 11: Maintaining & Servicing Appliance

A. Maintenance Tasks .....	42
----------------------------	----

## Section 12: Reference Materials

A. Appliance Dimension Diagram .....	43
B. Vent Components Diagram .....	44
C. Vent Components List .....	46
D. Service Parts List.....	47
E. Warranty .....	50
F. Contact Information .....	52

➔ = Contains updated information.

# 1 Listing and Code Approvals

## A. Appliance Certification

<b>MODEL:</b>	Hudson Bay
<b>LABORATORY:</b>	OMNI Test Laboratories, Inc. 0061GS029S
<b>TYPE:</b>	Direct Vent Gas Heater
<b>STANDARD:</b>	ANSI Z21.88-2014 CSA 2.33-2014 CAN/CSA 2.17-M91 (R2009)

The product is listed to ANSI standards for "Vented Gas Appliance Heaters" and applicable sections of "Gas Burning Heating Appliances for Manufactured Homes and Recreational Vehicles" and "Gas Fired Appliances for use at High Altitudes".

Manufactured Home or Mobile Home installation may occur only after the home is site located and must conform with the Manufactured Home Construction and Safety Standard, Title 24 CFR, Part 3280, or, when such a standard is not applicable, the Standard for Manufactured Home Installations, ANSI/NCSCBS A225.1, or Standard for Gas Equipped Recreational Vehicles and Mobile Housing, CSA Z240.4.

When installed, the appliance must be electrically grounded in accordance with local codes or, in the absence of local codes, with the National Electrical Code, ANSI/NFPA 70, or the Canadian Electrical Code, CSA C22.1.

## B. Glass Specifications

This appliance is equipped with 5mm ceramic glass. Replace glass only with 5mm ceramic glass. Please contact your dealer for replacement glass.



Installation and service of this appliance should be performed by qualified personnel. Hearth & Home Technologies suggests NFI certified or factory-trained professionals, or technicians supervised by an NFI certified professional.

**NOTE:** This installation must conform with local codes. In the absence of local codes you must comply with the **National Fuel Gas Code, ANSI Z223.1-latest edition** in the U.S.A. and the **CAN/CGA B149 Installation Codes** in Canada.



## WARNING

Do NOT use this appliance if any part has been under water. Immediately call a qualified service technician to inspect the unit and to replace any part of the control system and any gas control which has been under water.

## C. BTU Specifications

<b>Model</b> <i>(US or Canada)</i>	Maximum Input BTU	Minimum Input BTU	Orifice Size (DMS)	*Steady State Efficiency %	**P.4 %
<b>Hudson Bay (NG)</b>	42,000	28,000	.125	84.02	64.03
<b>Hudson Bay (LP)</b>	40,500	31,000	.076	85.71	65.43

\* Thermal efficiency maximum pipe with blower on.

\*\* Canada minimum pipe.

## D. High Altitude Installations

Omni-Test Laboratories listed gas appliances are tested and approved without requiring changes for elevations from 0 to 2000 feet in the U.S.A. and 0 to 4500 feet in Canada.

When installing this appliance at an elevation above 2000 feet, it may be necessary to decrease the input rating by changing the existing burner orifice to a smaller size. Input rate should be reduced by 4% for each 1000 feet above a 2000 foot elevation in the U.S.A. If the heating value of the gas has been reduced, these rules do not apply. To identify the proper orifice size, check with the local gas utility.

If installing this appliance at an elevation above 4500 feet (in Canada), check with local authorities.

## E. Non-Combustible Materials

Materials that are reported as passing ASTM E 136, Standard Test Method for Behavior of Materials in a Vertical Tube Furnace at 750°C, shall be considered non-combustible materials.

## F. Combustible Materials

Materials made of or surfaced with wood, compressed paper, plant fibers, plastics, or other materials that can ignite and burn, whether flame proofed or not, or whether plastered or un-plastered shall be considered combustible materials.

## G. Electrical Codes

**NOTICE:** *This appliance must be electrically wired and grounded in accordance with local codes or, in the absence of local codes, with National Electric Code ANSI/NFPA 70-latest edition or the Canadian Electric Code CSA C22.1.*

- A 110-120 VAC circuit for this product must be protected with ground-fault circuit-interrupter protection, in compliance with the applicable electrical codes, when it is installed in locations such as in bathrooms or near sinks.

**NOTE:** The following requirements reference various Massachusetts and national codes not contained in this document.

## H. Requirements for the Commonwealth of Massachusetts

For all side wall horizontally vented gas fueled equipment installed in every dwelling, building or structure used in whole or in part for residential purposes, including those owned or operated by the Commonwealth and where the side wall exhaust vent termination is less than seven (7) feet above finished grade in the area of the venting, including but not limited to decks and porches, the following requirements shall be satisfied:

### Installation of Carbon Monoxide Detectors

At the time of installation of the side wall horizontal vented gas fueled equipment, the installing plumber or gas fitter shall observe that a hard wired carbon monoxide detector with an alarm and battery back-up is installed on the floor level where the gas equipment is to be installed. In addition, the installing plumber or gas fitter shall observe that a battery operated or hard wired carbon monoxide detector with an alarm is installed on each additional level of the dwelling, building or structure served by the side wall horizontal vented gas fueled equipment. It shall be the responsibility of the property owner to secure the services of qualified licensed professionals for the installation of hard wired carbon monoxide detectors.

In the event that the side wall horizontally vented gas fueled equipment is installed in a crawl space or an attic, the hard wired carbon monoxide detector with alarm and battery back-up may be installed on the next adjacent floor level.

In the event that the requirements of this subdivision can not be met at the time of completion of installation, the owner shall have a period of thirty (30) days to comply with the above requirements; provided, however, that during said thirty (30) day period, a battery operated carbon monoxide detector with an alarm shall be installed.

### Approved Carbon Monoxide Detectors

Each carbon monoxide detector as required in accordance with the above provisions shall comply with NFPA 720 and be ANSI/UL 2034 listed and IAS certified.

### Signage

A metal or plastic identification plate shall be permanently mounted to the exterior of the building at a minimum height of eight (8) feet above grade directly in line with the exhaust vent terminal for the horizontally vented gas fueled heating appliance or equipment. The sign shall read, in print size no less than one-half (1/2) inch in size, **“GAS VENT DIRECTLY BELOW. KEEP CLEAR OF ALL OBSTRUCTIONS.”**

### Inspection

The state or local gas inspector of the side wall horizontally vented gas fueled equipment shall not approve the installation unless, upon inspection, the inspector observes carbon monoxide detectors and signage installed in accordance with the provisions of 248 CMR 5.08(2)(a) 1 through 4.

### Exemptions

The following equipment is exempt from 248 CMR 5.08(2)(a) 1 through 4:

- The equipment listed in Chapter 10 entitled “Equipment Not Required To Be Vented” in the most current edition of NFPA 54 as adopted by the Board; and
- Product Approved side wall horizontally vented gas fueled equipment installed in a room or structure separated from the dwelling, building or structure used in whole or in part for residential purposes.

## MANUFACTURER REQUIREMENTS

### Gas Equipment Venting System Provided

When the manufacturer of Product Approved side wall horizontally vented gas fueled equipment provides a venting system design or venting system components with the equipment, the instructions provided by the manufacturer for installation of the equipment and the venting system shall include:

- Detailed instructions for the installation of the venting system design or the venting system components; and
- A complete parts list for the venting system design or venting system.

### Gas Equipment Venting System NOT Provided

When the manufacturer of a Product Approved side wall horizontally vented gas fueled equipment does not provide the parts for venting the flue gases, but identifies “special venting systems”, the following requirements shall be satisfied by the manufacturer:

- The referenced “special venting system” instructions shall be included with the appliance or equipment installation instructions; and
- The “special venting system” shall be Product Approved by the Board, and the instructions for that system shall include a parts list and detailed installation instructions.

A copy of all installation instructions for all Product Approved side wall horizontally vented gas fueled equipment, all venting instructions, all parts lists for venting instructions, and/or all venting design instructions shall remain with the appliance or equipment at the completion of the installation.

**See Gas Connection section for additional Commonwealth of Massachusetts requirements.**

# 2 Getting Started

## A. Design & Installation Considerations

Quadra-Fire direct vent gas appliances are designed to operate with all combustion air siphoned from outside of the building and all exhaust gases expelled to the outside. No additional air source is required.

### CAUTION

Check building codes prior to installation.

- Installation **MUST** comply with local, regional, state and national codes and regulations.
- Consult local building, fire officials or authorities having jurisdiction about restrictions, installation inspection, and permits.

When planning an installation, it is necessary to determine the following information before installing:

- Where the appliance is to be installed.
- The vent system configuration to be used.
- Gas supply piping.
- Electrical wiring.
- Whether optional accessories - devices such as a blower, thermostat or remote control - are desired.

### WARNING



Keep appliance dry.

- Mold or rust may cause odors.
- Water may damage controls.



## B. Tools and Supplies Needed

Before beginning the installation be sure that the following tools and building supplies are available. **Note: Not all tools will apply to every installation.**

Reciprocating saw	Variable Speed Drill/Driver
Pliers	Wrench Set
Hammer	Framing Square
Phillips Screwdriver	Framing Material
Flat Blade Screwdriver	Voltmeter
Plumb Line	Gloves
Level	Safety Glasses
Manometer	Non-corrosive Leak Check Solution or combustible gas detector
Tape Measure	Caulking material (300° F minimum continuous exposure rating)

## C. Inspect Appliance & Components

### WARNING



Inspect appliance and components for damage. Damaged parts may impair safe operation.

- Do NOT install damaged components.
- Do NOT install incomplete components.
- Do NOT install substitute components.



Report damaged parts to dealer.

- Carefully remove the appliance and components from the packaging.
- Remove cast door and glass door, and set aside on protective surface.
- Remove log set and component pack from firebox.
- Report to your dealer any parts damaged in shipment, particularly the condition of the glass.
- **Read all of the instructions before starting the installation. Follow these instructions carefully during the installation to ensure maximum safety and benefit.**

### WARNING



Hearth & Home Technologies disclaims any responsibility for, and the **warranty will be voided** by, the following actions:

- Installation and use of any damaged appliance or vent system component.
- Modification of the appliance or vent system.
- Installation other than as instructed by Hearth & Home Technologies.
- Improper positioning of the gas logs or the glass door.
- Installation and/or use of any component part not approved by Hearth & Home Technologies.

**Any such action may cause a fire hazard.**

# 3 Appliance Location and Clearances

**NOTE:**

- Illustrations reflect typical installations and are FOR DESIGN PURPOSES ONLY.
- Illustrations/diagrams are not drawn to scale.
- Actual installation may vary due to individual design preference.

## A. Selecting Appliance Location

When selecting a location for your appliance it is important to consider the required clearances to walls (see **Figure 3.1**).

**NOTE:** For actual appliance dimensions refer to Section 12.

## B. Clearances

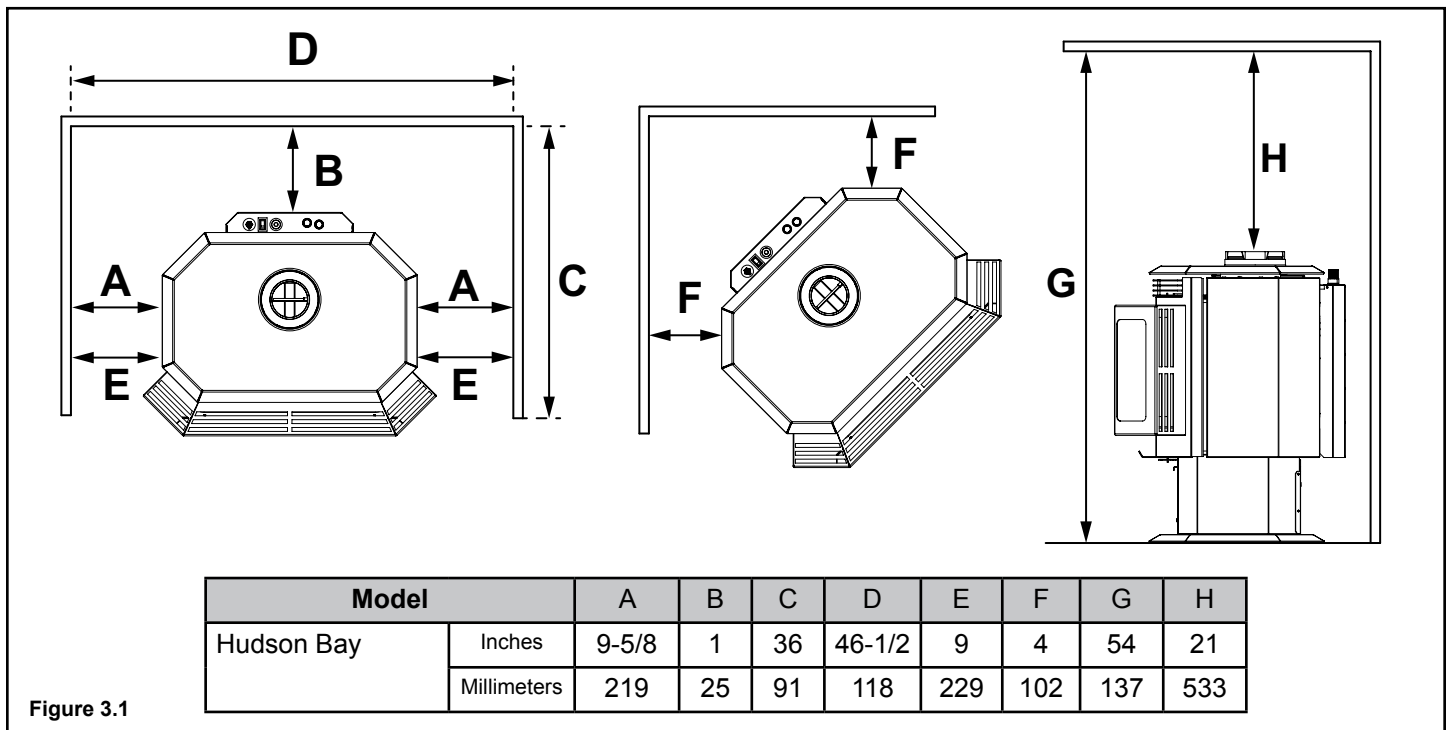

Figure 3.1

It is permissible to place the appliance on carpet.

**CAUTION**

Some carpet materials may be sensitive to radiant heat from the appliance causing discoloration or odor.

**NOTE:** Flooring beneath appliance may reach 90 degrees plus room ambient temperature. Check with flooring manufacturer for maximum temperature allowed on flooring surfaces.

**WARNING**



Fire Risk  
Provide adequate clearance:  

- Around air openings
- To combustibles
- For service access

 Locate appliance away from traffic areas.

**WARNING**



Fire Risk.  

- Locate and install appliance to all clearance specifications in manual.

**WARNING**



Fire Risk.  
 Odor Risk.  
 Tipping Risk  

- Install appliance on a stable, level platform/ floor strong enough to support appliance without tipping.
- USE wood flooring, ceramic tile, brick hearth or high pressure laminate flooring applied directly over the sub-flooring material.



# 4 Termination Locations

## A. Vent Termination Minimum Clearances

### ⚠ WARNING



Fire Risk.

Explosion Risk.

Maintain vent clearance to combustibles as specified.



- Do not pack air space with insulation or other materials.

Failure to keep insulation or other materials away from vent pipe may cause fire.

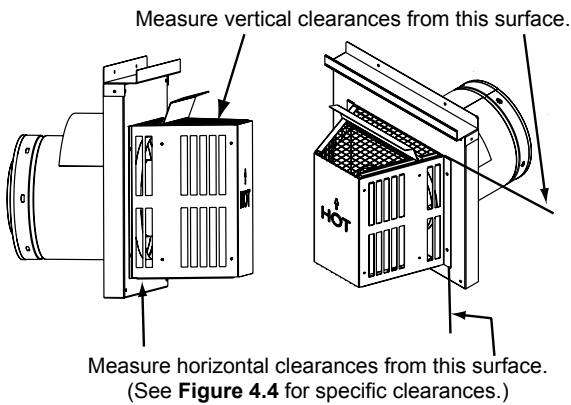
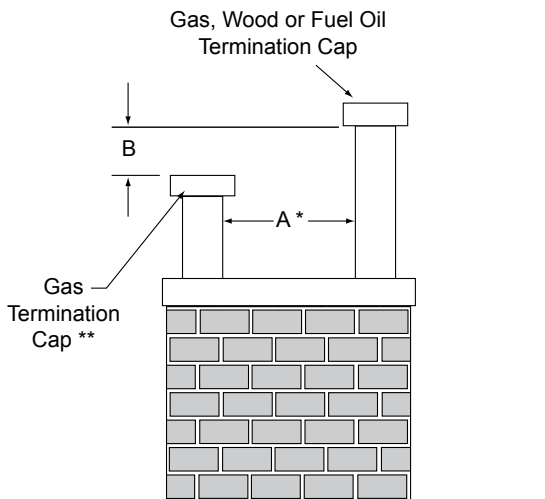

Figure 4.1 Termination Clearances

A	B
6 in. (minimum) up to 20 in. 152 mm/508 mm	18 in. minimum 457 mm
20 in. and over	0 in. minimum



\* If using decorative cap cover(s), this distance may need to be increased. Refer to the installation instructions supplied with the decorative cap cover.

\*\* In a staggered installation with both gas and wood or fuel oil terminations, the wood or fuel oil termination cap must be higher than the gas termination cap.

Figure 4.2 Multiple Vertical Termination

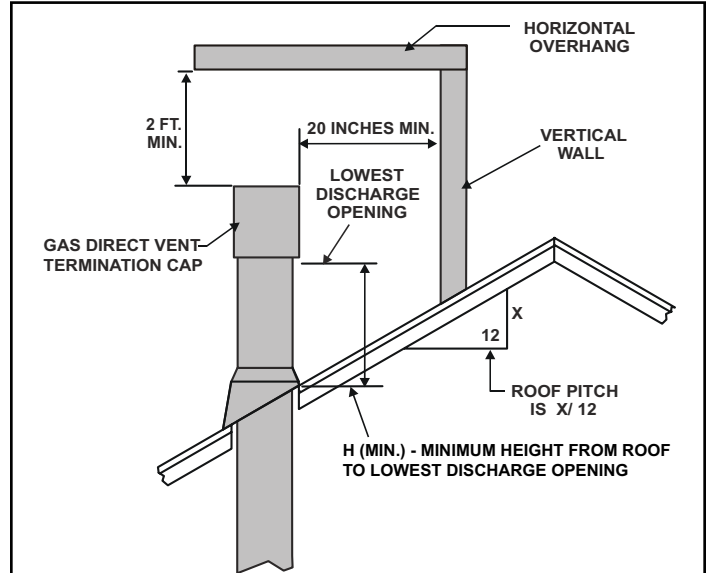

Roof Pitch	H (Min.) Ft
Flat to 6/12	1.0*
Over 6/12 to 7/12	1.25
Over 7/12 to 8/12	1.5*
Over 8/12 to 9/12	2.0*
Over 9/12 to 10/12	2.5*
Over 10/12 to 11/12	3.25
Over 11/12 to 12/12	4.0
Over 12/12 to 14/12	5.0
Over 14/12 to 16/12	6.0

Figure 4.3 Minimum Height from Roof to Lowest Discharge Opening

Figure 4.3 specifies minimum vent heights for various pitched roofs.



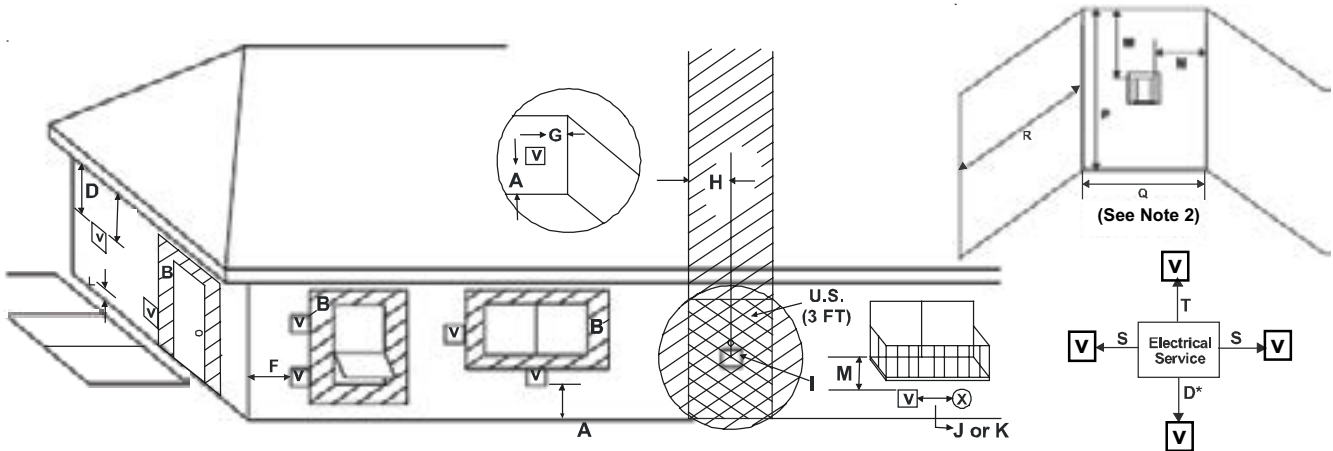

**V** = VENT TERMINAL      **X** = AIR SUPPLY INLET      **▨** = AREA WHERE TERMINAL IS NOT PERMITTED

<p>A = 12 inches ..... clearances above grade, veranda, porch, deck or balcony (See Note 1)</p> <p>B = 12 inches ..... clearances to window or door that may be opened, or to permanently closed window. (Glass)</p> <p>D* = 18 inches ..... vertical clearance to unventilated soffit or to ventilated soffit located above the terminal *30 inches ..... for vinyl clad soffits and below electrical service</p> <p>F = 9 inches ..... clearance to outside corner</p> <p>G = 6 inches ..... clearance to inside corner</p> <p>H = 3 ft. (Canada) ..... not to be installed above a gas meter/regulator assembly within 3 feet (90cm) horizontally from the center-line of the regulator</p> <p>I = 3 ft. .... clearance to gas service regulator vent outlet</p> <p>J = 9 inches (U.S.A.) 12 inches (Canada) clearance to non-mechanical air supply inlet to building or the combustion air inlet to any other appliance</p>	<p>K = 3 ft. (U.S.A.) 6 ft. (Canada) ..... clearance to a mechanical (powered) air supply inlet</p> <p>L** = 7 ft. .... clearance above paved sidewalk or a paved driveway located on <b>public</b> property (See Note 1)</p> <p>M*** = 18 inches ..... clearance under veranda, porch, deck, balcony or overhang 42 inches ..... vinyl</p> <p>S = 6 inches ..... clearance from sides of electrical service (See Note 3)</p> <p>T = 12 inches ..... clearance above electrical service (See Note 3)</p>
---	--

Alcove Applications		
N = 6 inches ..... non-vinyl sidewalls		
12 inches ..... vinyl sidewalls		
P = 8 ft.		
	<b>Q<sub>MIN</sub></b>	<b>R<sub>MAX</sub></b>
1 cap	3 feet	2 x Q <sub>ACTUAL</sub>
2 caps	6 feet	1 x Q <sub>ACTUAL</sub>
3 caps	9 feet	2/3 x Q <sub>ACTUAL</sub>
4 caps	12 feet	1/2 x Q <sub>ACTUAL</sub>
<b>Q<sub>MIN</sub></b> = # termination caps x 3 <b>R<sub>MAX</sub></b> = (2 / # termination caps) x Q <sub>ACTUAL</sub>		

\*\* a vent shall not terminate directly above a sidewalk or paved driveway which is located between two single family dwellings and serves both dwellings.

\*\*\* only permitted if veranda, porch, deck or balcony is fully open on a minimum of 2 sides beneath the floor, or meets Note 2.

**NOTE 1:** On private property where termination is less than 7 feet above a sidewalk, driveway, deck, porch, veranda or balcony, use of a listed cap is suggested. (See vents components pages.)

**NOTE 2:** Termination in an alcove space (spaces only open on one side and without an overhang) are permitted with the dimensions specified for vinyl or non-vinyl siding and soffits. **1.** There must be at least 3 feet minimum between termination caps. **2.** All mechanical air intakes within 10 feet of a termination cap must be a minimum of 3 feet below the termination cap. **3.** All gravity air intakes within 3 feet of a termination cap must be a minimum of 1 foot below the termination cap.

**NOTE 3:** Location of the vent termination must not interfere with access to the electrical service.

**NOTE:** Local codes or regulations may require different clearances.

**NOTE:** Termination caps may be hot. Consider their proximity to doors or other traffic areas.

**WARNING: In the U.S.:** Vent system termination is **NOT** permitted in screened porches. You must follow side wall, overhang and ground clearances as slated in the instructions.

**In Canada:** Vent system termination is **NOT** permitted in screened porches. Vent system termination is permitted in porch areas with two or more sides open. You must follow side wall, overhang and ground clearances as stated in the instructions.

Quadra-Fire assumes no responsibility for the improper performance of the appliance when the venting system does not meet these requirements.

**CAUTION: IF EXTERIOR WALLS ARE FINISHED WITH VINYL SIDING, IT IS SUGGESTED THAT A VINYL PROTECTOR KIT BE INSTALLED (part #VPK-DV).**

Figure 4.4

# 5 Vent Information

## A. Venting Components

In order to comply with applicable codes and product warranties, use only following venting components:



- Hearth & Home Technologies (HHT)
- Security Chimney's Secure Vent Chimney System
- Selkirk Metalbestos
- AmeriVent
- Simpson Dura-Vent (SDV)

**DO NOT USE FIELD-FABRICATED VENTING COMPONENTS.** Refer to the venting manufacturer's instructions.

This product is approved to be vented either horizontally, through the side wall or vertically through the roof. You may vent through a Class A or masonry chimney if an approved adapter is used.

This appliance is a direct vent heater. All combustion air must come directly from the outside of the building. The vent pipe for this unit consists of an inner and an outer pipe. The inner pipe carries the appliance exhaust out of the system, and the outer pipe brings fresh combustion air into the appliance.

- A round support box/wall thimble or heat shield is required when the venting passes through a combustible wall.
- A support box or ceiling firestop is required when the venting passes through a ceiling.
- Roof flashing and a storm collar are required when venting passes through the roof.
- Follow instructions provided with the venting for installation of these items.

 <b>WARNING</b>	
	Fire Hazard.
	Explosion Risk.
	Asphyxiation Risk.
	Do NOT connect this gas appliance to a chimney flue serving a separate solid-fuel or gas burning appliance.
	<ul style="list-style-type: none"><li>• Vent this appliance directly outside.</li><li>• Use separate vent system for this appliance.</li></ul>
	May impair safe operation of this appliance or other appliances connected to the flue.

## B. Use of Elbows

 <b>CAUTION</b>
ALL vent configuration specifications MUST be followed.
<ul style="list-style-type: none"><li>• This product is tested and listed to these specifications.</li><li>• Appliance performance will suffer if specifications are not followed.</li></ul>

Diagonal runs have both vertical and horizontal vent aspects when calculating the effects. Use the rise for the vertical aspect and the run for the horizontal aspect. (See **Figure 5.1.**)

Two 45° elbows may be used in place of one 90° elbow. On 45° runs, one foot of diagonal is equal to 8-1/2 in. (216mm) horizontal run and 8-1/2 in. (216mm) vertical run. A length of straight pipe is allowed between two elbows. (See **Figure 5.1.**)

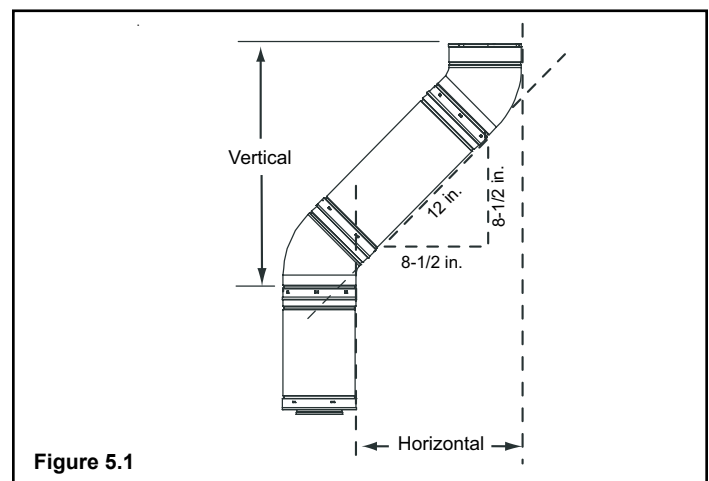

Figure 5.1

## C. Measuring Standards

Vertical and horizontal measurements were made using the following standards.

- Pipe measurements are from center line to center line.
- Horizontal terminations are measured to the outside of the mounting surface (flange of termination cap). See **Figure 4.1** on page 8.
- Vertical terminations are measured to the top of the last pipe before termination cap.
- Horizontal pipe installed level with 1/4 in. rise for every 12 in. of horizontal travel.

### D. How to Use the Vent Graph

1. Measure the distance from the top of appliance to the center of the 90° elbow. On the graph below, draw a horizontal line from that measurement on the vertical axis across until it intersects with the slanted line.
2. From the point of this intersection, draw a vertical line to the bottom of the graph.
3. The point at which this line meets the bottom line of the graph is the maximum length of the horizontal run.

**Example 1:** If the vertical dimension from the top of the appliance to the center of the 90° elbow is 7 ft. (2m), the horizontal run to the outer wall flange must not exceed 10' ft. 6 in.

**Example 2:** If the vertical dimension from the top of the appliance is 21 ft. (6m), the horizontal run to the outer wall flange must not exceed 9 ft. (3m).

4. Each 90° elbow is equivalent to 3 ft. (914mm) of vent pipe and each 45° elbow is equivalent to 1 ft. (305mm) of vent pipe, and must be subtracted from vent pipe run. A single vertical to horizontal 90° elbow is already calculated into the allowable 15 ft. (5m) run. Each additional 90° elbow reduces the maximum horizontal distance by 3 ft. (914mm).

**Example:** The use of 3 elbows would reduce the allowable horizontal run to 9 ft. (3 - 1 = 2 elbows x 3 ft. = 6 ft.; 15 ft. max. - 6 ft. = 9 ft. max.)

### E. Venting Guidelines

#### NOTES

The maximum horizontal vent run is 15 ft. (5m) with a minimum vertical vent rise of 10 ft. (3m).

The minimum horizontal vent run is 11 in. (279mm).

Minimum wall thickness is 4 in. (102mm). Maximum wall thickness is 20 in. (508mm).

Horizontal sections require a 1/4 in. (6mm) rise for every 12 in. (305mm) of horizontal travel.

Exterior Vent Diameter = 6 5/8 in. (168mm); Inner Vent Diameter = 4 in. (101mm)

Horizontal sections require noncombustible support every 3 ft. (914mm), e.g. wall straps.

Maximum 90° elbows for horizontal termination is 3.

Maximum 90° elbows for vertical termination is 4.

**NOTE:** IF YOUR INSTALLATION FALLS WITHIN A SHADED AREA ON THE GRAPH, THE DAMPER MUST BE USED. (In the Commonwealth of Massachusetts, the word damper shall be replaced with the words flue restrictor.)

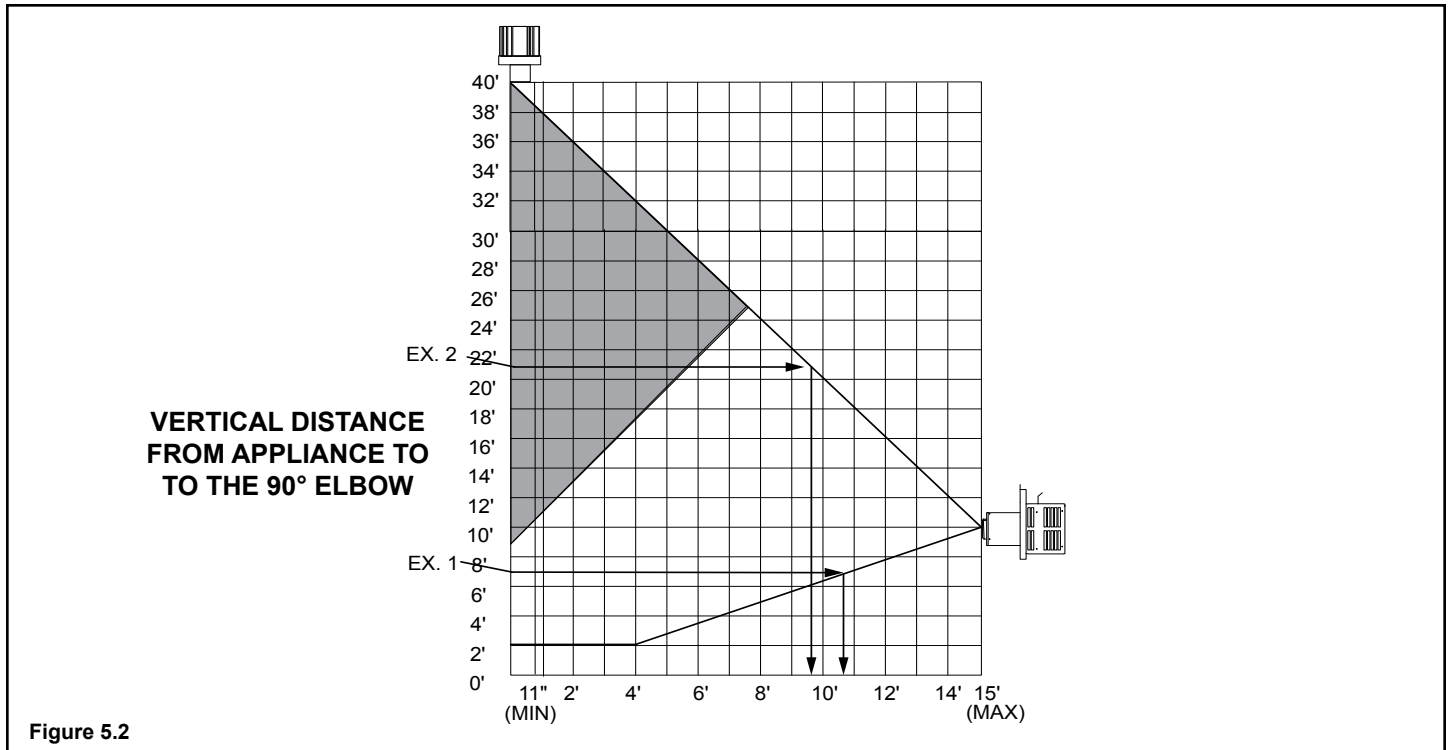

**TOTAL HORIZONTAL RUN TO OUTSIDE OF EXTERIOR WALL (INCLUDING ELBOWS)**

## F. Horizontal Termination

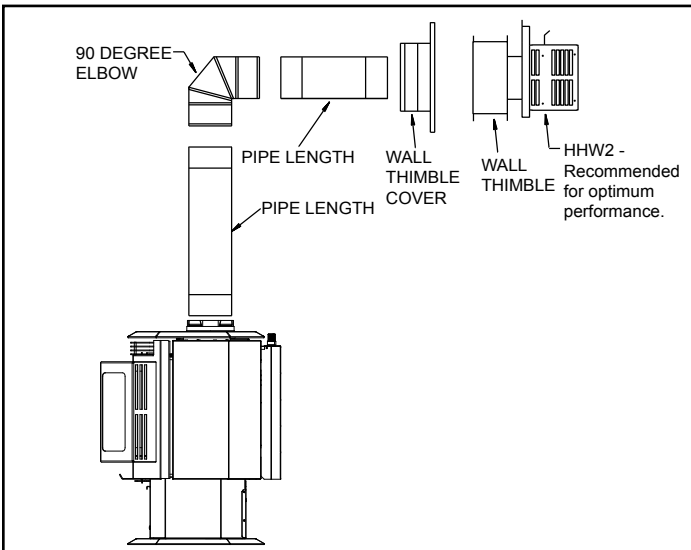

Figure 5.3

### Step 1.

Determine the desired location of the appliance. Check to ensure that wall studs or roof rafters are not in the way when the venting system is attached. If this is the case, you may want to adjust the location of the appliance.

<b>WARNING</b>	
<p>Fire Hazard. Exhaust Fume Risk. Impaired Performance of Appliance.</p> <ul style="list-style-type: none"> <li>• Ensure vent components are locked together correctly.</li> <li>• Pipe may separate if not properly joined.</li> </ul>	

### Step 2.

Direct vent pipe is designed with a locking connection. To connect the venting system to the appliance flue outlet, a twist-lock adapter is built into the appliance at the factory. Remember to include wall thickness in minimum clearances when figuring the measurements for your installation needs.

**Note:** Direct vent pipe is designed to slide straight onto the male ends of adjacent pipes and fittings by orienting the pipe indentations so they match and slide into the entry slots on the male ends, see **Figure 5.4**. Push the pipe sections completely together, then twist-lock one section clockwise approximately one-quarter turn, until the two sections are fully locked. The female locking lugs may not be visible from the outside, on the pipe or fittings. They may be located by examining the inside of the female ends.

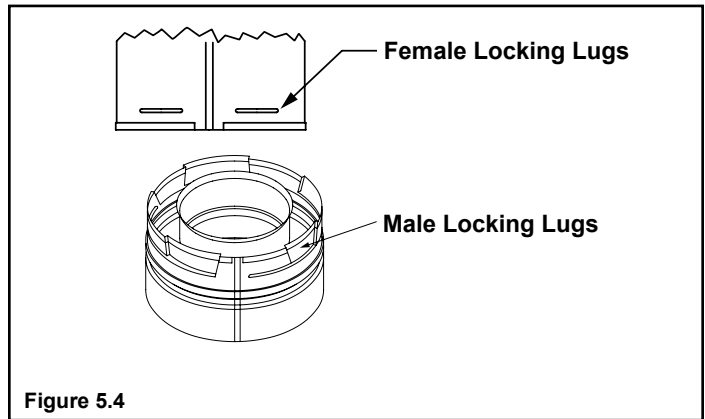
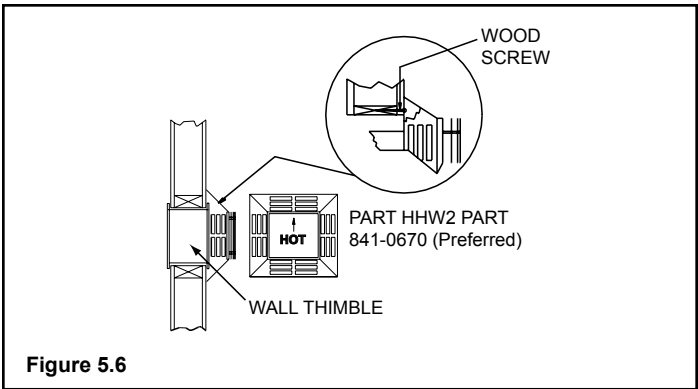
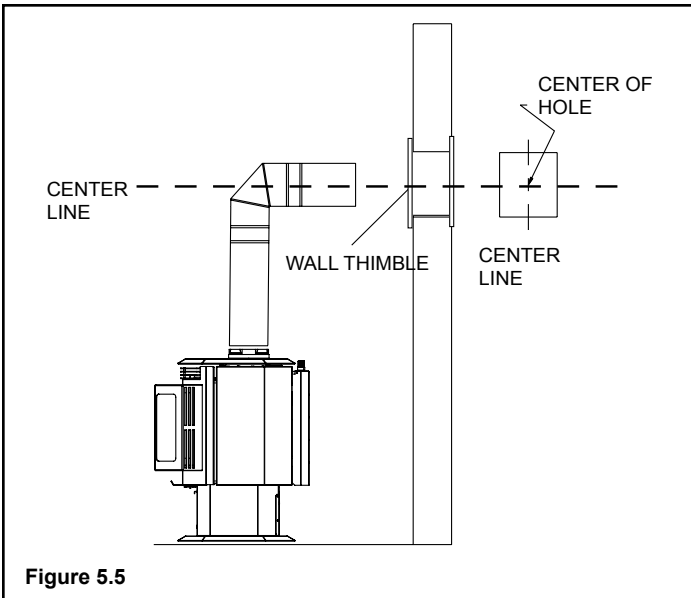

Figure 5.4

<b>WARNING</b>	
	<p>Fire Risk. Explosion Risk. Combustion Fume Risk.</p>
	<p>Use vent run supports per installation instructions. Connect vent sections per installation instructions.</p> <ul style="list-style-type: none"> <li>• Maintain all clearances to combustibles.</li> <li>• Do NOT allow vent to sag below connection point to appliance.</li> <li>• Maintain specified slope (if required).</li> </ul> <p>Improper support may allow vent to sag or separate.</p>

### Step 3.

For installations using a support box/wall thimble (check pipe manufacturer's instructions), mark the wall for a 10 in. x 10 in. (254mm x 254mm) square hole. The center of the square hole should line up with the center line of the horizontal pipe, as shown in **Figure 5.5**, on the next page. Cut and frame the hole in the exterior wall where the vent will be terminated. If the wall being penetrated is constructed of noncombustible material, i.e. masonry block or concrete, a 7 in. (178mm) diameter hole is acceptable.



**NOTES:**

1. The four wood screws provided should be replaced with appropriate fasteners for stucco, brick, concrete, or other types of sidings.
2. Termination cap HHW2 (Part #841-0670) is highly recommended on a building with vinyl siding, as the vinyl siding standoff is built in. The pilot hole will be 2 in. (51mm) closer to the bottom of the square than the top. Using a framing square, draw a 14 in. x 14 in. (356mm x 356mm) square around the pilot hole in the siding. See **Figure 5.7**.

**NOTE:**

1. Installation requires a minimum of 6 in. (152mm) horizontal run of vent with a 1/4 in. (6mm) rise run towards the termination. Each 1 ft. (305mm) of horizontal venting must include a 1/4 in. (6mm) rise. Never allow the vent to run downward. This could cause high temperatures and may present the possibility of a house or structure fire.
2. The location of the horizontal vent termination on an exterior wall must meet all local and national building codes, and must not be easily blocked or obstructed, see **Figure 4.4** on page 8.
3. For installations requiring a vertical rise on the exterior of the building, the HHT RHVK snorkel kit (Part #844-8921) is available with a 14 in. (356mm) and a 36 in. (914mm) tall snorkel termination cap. Follow the same installation procedures as used for standard horizontal terminations. If the snorkel termination must be installed below grade (i.e. basement application), proper drainage must be provided to prevent water from entering the snorkel termination. Do not backfill around snorkel termination.

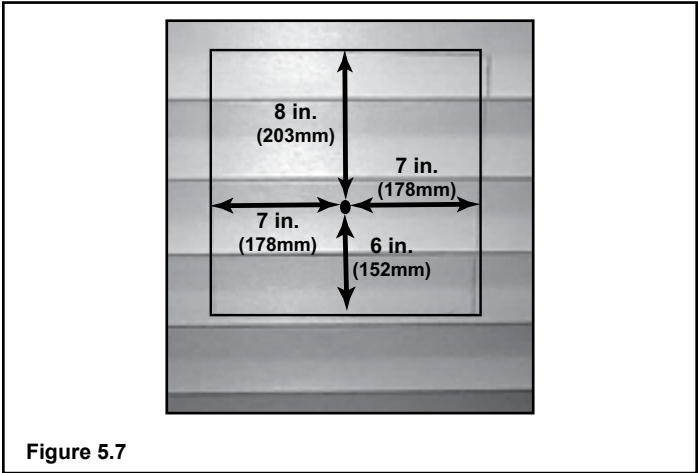

**Step 4.**

Position the horizontal termination cap in the center of the 10 in. x 10 in. (254mm x 254mm) square hole and run a bead of non-hardening mastic around its outside edges, so as to make a seal between it and the wall, attach termination cap to the exterior wall with the four wood screws provided. The arrow on the vent cap should be pointing up (**Figure 5.6**).

(**NOTE:** If you are installing termination cap HHW2, the pipe will be off center on the flashing). Ensure that proper clearances to combustible materials are maintained. If you are using an approved termination cap other than HHW2 on a building with vinyl siding, a vinyl siding standoff should be installed between the vent cap and the exterior wall (**Figure 5.8**, on the next page). Attach the vinyl siding standoff to the horizontal termination cap. The vinyl siding standoff prevents excessive heat from possibly melting the vinyl siding material. The vent termination cap shall not be recessed into a wall or siding. Remove siding from the area where the standoff will be located.

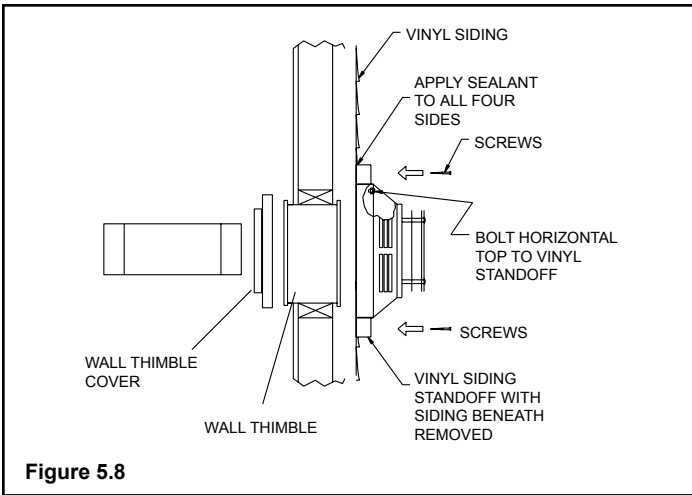

**⚠ WARNING**

Fire Hazard.  
Exhaust Fume Risk.  
Impaired Performance of Appliance.

- Ensure vent components are locked together correctly.
- Pipe may separate if not properly joined.

**⚠ WARNING**

Do NOT connect a pipe section to a termination cap without using the telescoping flue section found on the termination cap.

**⚠ WARNING**

Burn Risk.

- Local codes may require installation of a cap shield to prevent anything or anyone from touching the hot cap.

**Step 5.**  
Place the wall thimble cover over the pipe assembly and slide the appliance and vent assembly towards the wall, carefully inserting the vent pipe into the vent termination cap assembly. It is important that the vent pipe extend into the vent termination cap a sufficient distance so as to result in a minimum pipe overlap of 1-1/4 in. (32mm). Secure the connection between the vent pipe and the vent termination cap by attaching the two sheet metal strips extending from the vent termination cap assembly into the outer wall of the vent pipe. Use the two sheet metal screws provided to connect the strips to the pipe section (**Figure 5.9**).

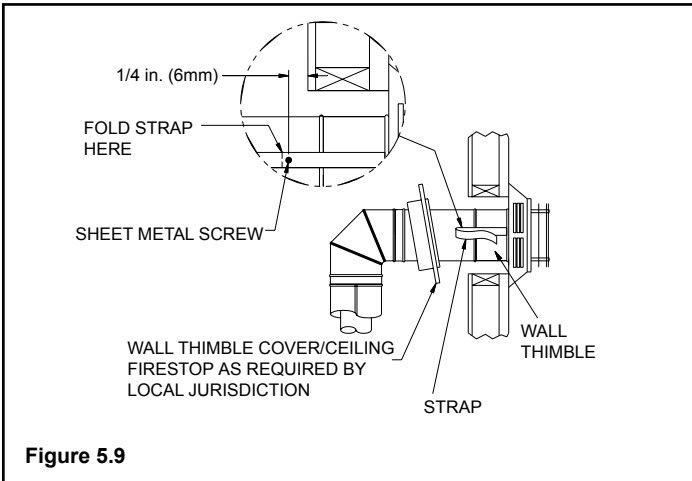

**Note:** The attachment from the vent pipe to the vent termination cap must be sealed with silicone. Termination caps shall not be recessed into a wall or siding.

## G. Vertical Termination

### 1. Direct Vent Pipe

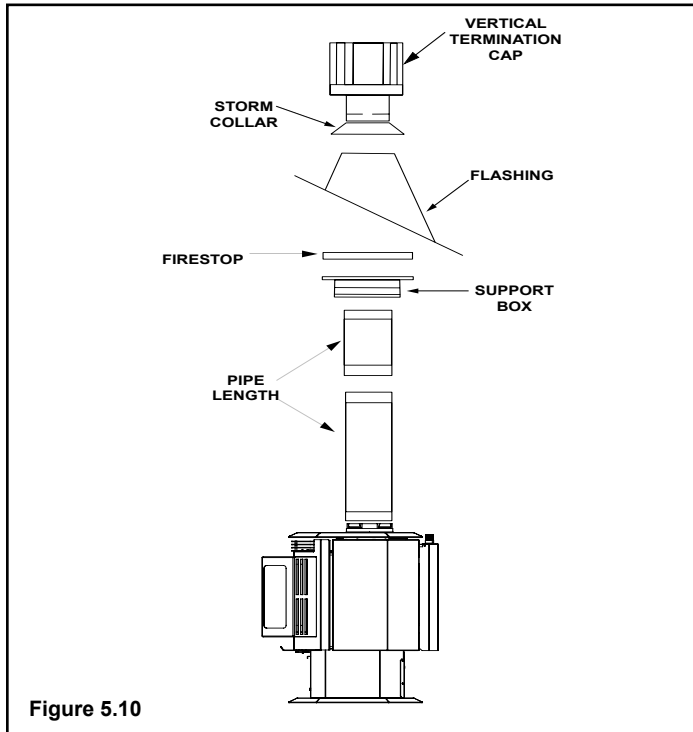





Figure 5.10

#### Step 1.

Check the installation instructions for required 1 in. (25mm) clearances (air space) to combustibles when passing through ceilings, walls, roofs, enclosures, attic rafters, or other nearby combustible surfaces. See page 17, **Figure 5.16**. Check the instructions below for maximum vertical rise of the venting system, and any maximum horizontal offset limitations. All offsets must fall within the set parameters of the vent graph (**Figure 5.2**) located on page 11.

**NOTE:** Maximum vertical rise allowable is 40 ft. (12m) See **Figure 5.11**.

**NOTE:** Maximum number of 45° elbows permitted for a vertical installation is eight, provided their installation does not decrease maximum allowable horizontal run (as specified by vent graph, on page 11).

 <b>WARNING</b>	
	Fire Risk.
	Explosion Risk.
Maintain vent clearance to combustibles as specified.	
<ul style="list-style-type: none"> <li>Do not pack air space with insulation or other materials.</li> </ul>	
	Failure to keep insulation or other materials away from vent pipe may cause fire.

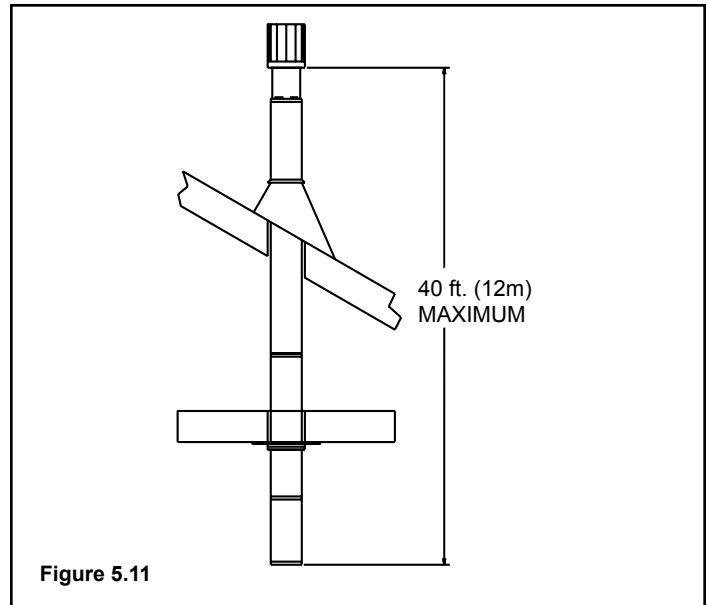

Figure 5.11

#### Step 2.

Set the gas appliance in its desired location. Drop a plumb bob down from the ceiling to the position of the appliance flue exit, and mark the location where the vent will penetrate the ceiling. Drill a small hole at this point. Next, drop a plumb bob from the roof to the hole previously drilled in the ceiling, and mark the spot where the vent will penetrate the roof. Determine if ceiling joists, roof rafters, or other framing will obstruct the venting system. You may wish to relocate the appliance, or to offset, as shown in **Figure 5.12** to avoid cutting load bearing members. When location is determined, drill small hole.

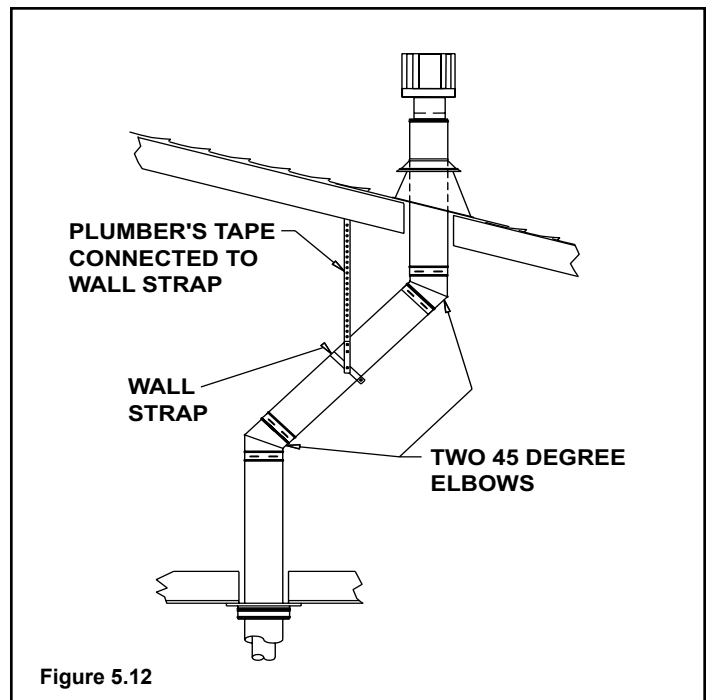
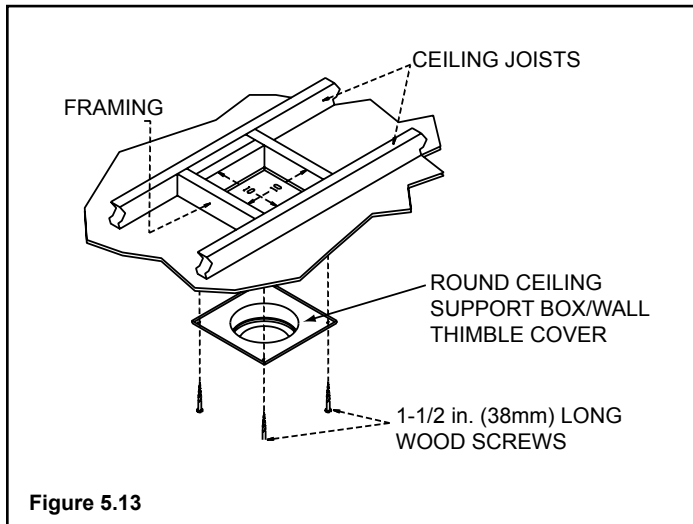

Figure 5.12

### Step 3.

To install the round support box/wall thimble cover in a flat ceiling, cut a 10 in. (254mm) square hole in the ceiling, centered on the hole drilled in Step 2. Frame the hole as shown in **Figure 5.13**.



### Step 4.

Assemble the desired lengths of pipe and elbows necessary to reach from the appliance up through the round support box. Ensure that all pipe and elbow connections are in their fully twist-locked position. Assemble as instructed.

### Step 5.

Cut a hole in the roof centered on the small drill hole placed in the roof in Step 2. The hole should be of sufficient size to meet the minimum requirements for clearance to combustibles, as specified. Continue to assemble lengths of pipe and elbows necessary to reach from the ceiling support box/wall thimble up through the roof line. Galvanized pipe and elbows may be utilized in the attic, as well as above the roof line. The galvanized finish is desirable above the roof line, due to its higher corrosion resistance.

### NOTE:

1. If an offset is necessary in the attic to avoid obstructions, it is important to support the vent pipe every 3 ft. (914mm) to avoid excessive stress on the elbows, and possible separation. Wall straps are available for this purpose, **Figure 5.12**, on page 15.
2. Whenever possible, use 45° elbows, instead of 90° elbows. The 45° elbow offers less restriction to the flow of flue gases and intake air.

### Step 6.

Slip the flashing over the pipe section(s) protruding through the roof. Secure the base of the flashing to the roof with roofing nails. Ensure the roofing material overlaps the top edge of the flashing as shown in **Figure 5.14**. Verify that the chimney is the required height above the roof. See roof pitch table, **Figure 4.3** on page 8.

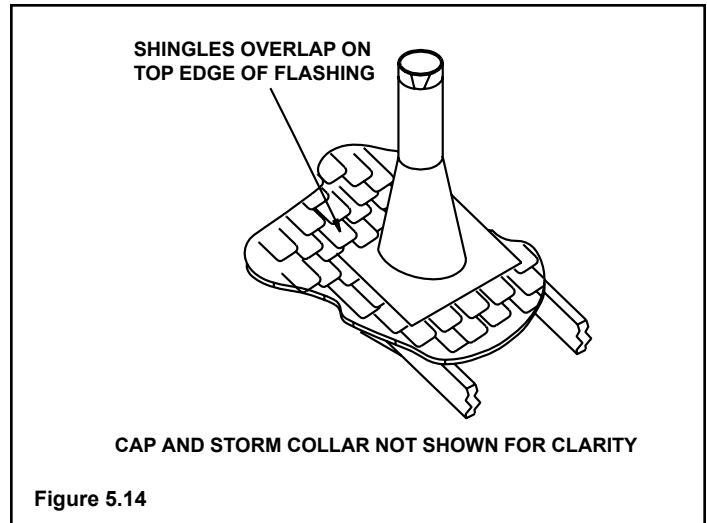

### Step 7.

Continue to assemble pipe sections until the height of the vent (before adding the termination cap) meets the minimum code requirements as outlined in the current CAN/CGA-B149 Installation Codes (in Canada), the National Fuel Gas Code NFPA 54/ANSI Z223.1 (in USA), or local codes. Note that for steep roof pitches, the vent height must be increased. See Roof Pitch Table (**Figure 4.3**, on page 8). In high wind conditions, nearby trees adjoining roof lines, steep pitched roofs, and other similar factors can result in poor draft, or down drafting. In these cases increasing the vent height or switching to the high wind termination cap may solve this problem.

### Step 8.

Slip the storm collar over the pipe, and push it down to the top of the flashing (**Figure 5.15**). Use non-hardening sealant above and below the joint between the storm collar and the pipe.

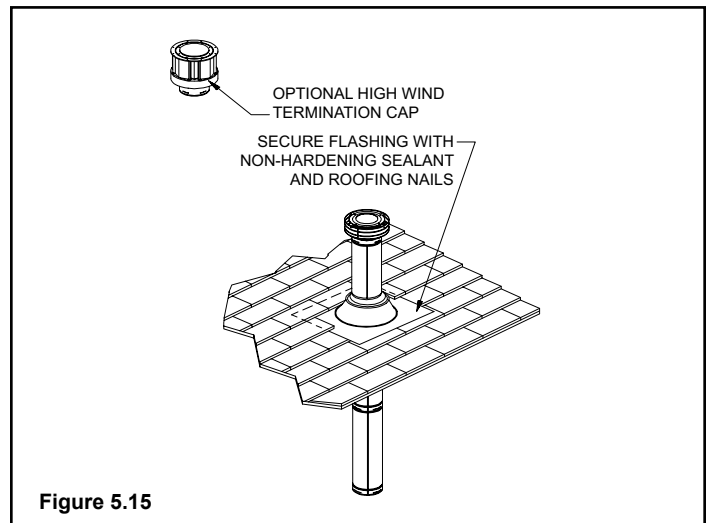



**Step 9.**

Twist-lock the vent cap and seal.

**Note:** For multi-story vertical installations, a ceiling firestop is required at the second floor, and any subsequent floors (**Figure 5.16**). The opening should be framed to 10 in. x 10 in. (254mm x 254mm) inside dimensions, in the same manner as shown in **Figure 5.13**, on page 16.

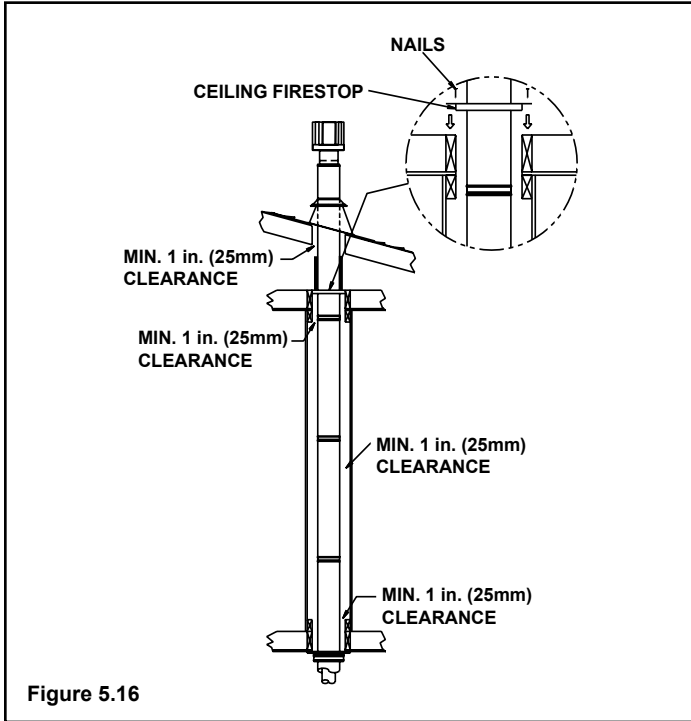

Figure 5.16



**WARNING**



Fire Risk.

Explosion Risk.



- Any occupied areas above the first floor, including closets and storage spaces, which the vertical vent passed through must be enclosed. The enclosure may be framed and sheet rocked with standard construction materials; however, refer to these installation instructions for the minimum allowable clearance between the outside of the vent pipe and the combustible surfaces of the enclosure. Do not fill any of the required air space with insulation.

## 2. Cathedral Ceiling

### Step 1.

Follow installation Steps 1 and 2 under vertical installation section, page 15.

### Step 2.

Remove shingles or other roof covering as necessary to cut the rectangular hole for the support box. Cut the hole 1/8 in. (3mm) larger than the support box outline.

### Step 3.

Lower the support box through the hole in the roof until the bottom of the support box protrudes at least 2 in. (51mm) below the ceiling (**Figure 5.17**). Align the support box both vertically and horizontally with a level. Temporarily tack the support box in place through the inside walls and into the roof sheathing.

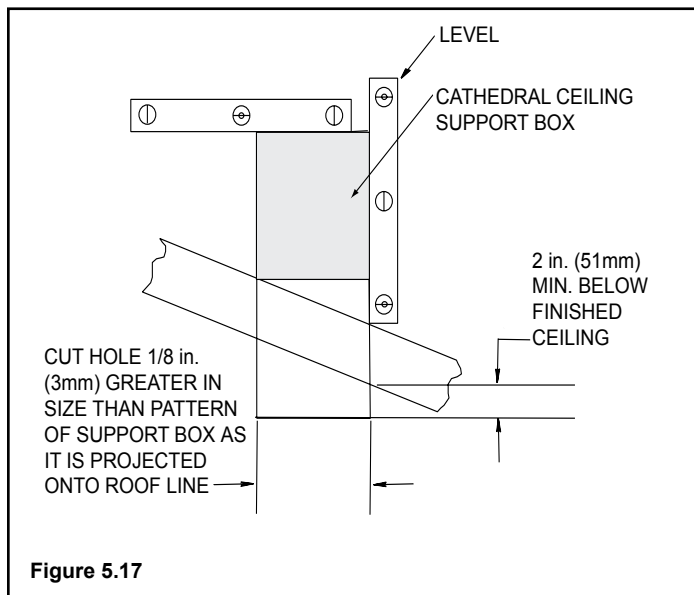

Figure 5.17

### Step 4.

Using tin snips, cut the support box from the top corners down to the roof line, and fold the resulting flaps over the roof sheathing (**Figure 5.18**). Before nailing it to the roof, run a bead of non-hardening mastic around the top edges of the support box to make a seal between it and the roof. Clean out any combustible material from inside the support box.

### Step 5.

Assemble the desired lengths of pipe and elbows necessary to reach from the appliance up through the round support box. Ensure that all pipe and elbow connections are in their fully twist-locked position. Assemble as instructed.

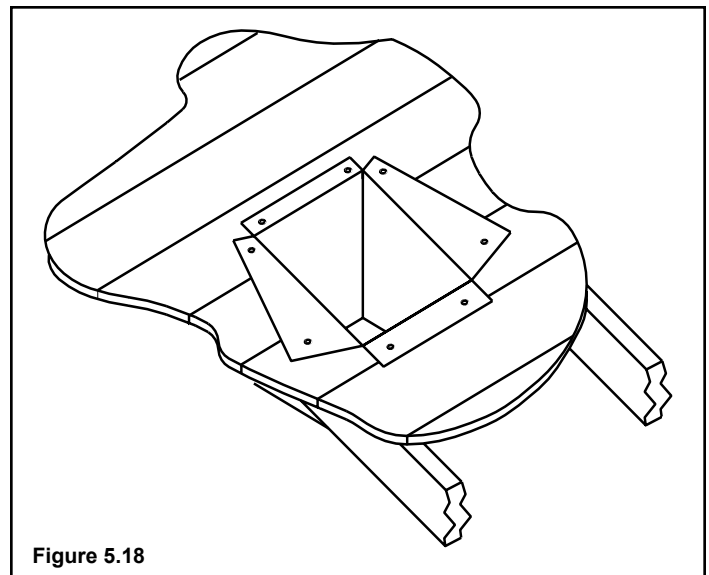

Figure 5.18

### Step 6.

Place the support clamp (provided with the support box) inside the support box (at the bottom), and secure to the pipe section. The clamp allows the support box to support the weight of the pipe sections. Continue to add pipe sections until you are above the roof line.

### Step 7.

Complete the cathedral ceiling installation by following the same procedures outlined in steps 7 through 9 for vertical installations, pages 16-17.

### Step 8.

Install the black trim collar around the outside of the cathedral ceiling support box (**Figure 5.19**). The two pieces of the trim collar slide over one another to allow for easy adjustment around the support box. Using the six screws provided, secure the four corners and the overlapping sections of the trim collar to the ceiling. You may want to predrill the holes for the overlapped sections for ease of installation.

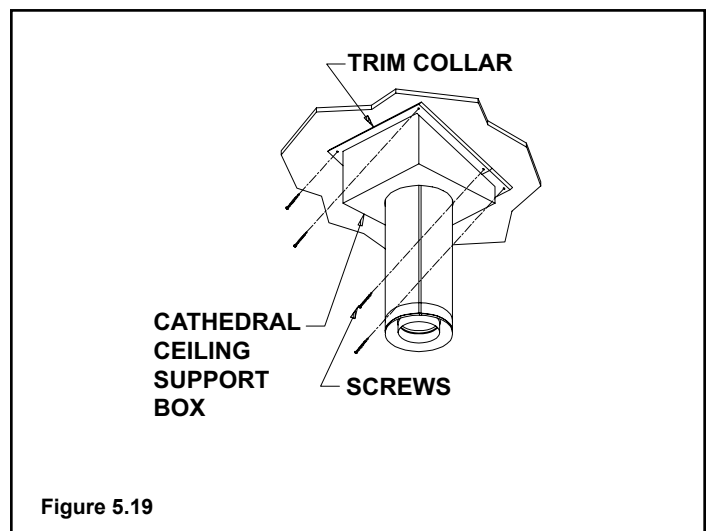

Figure 5.19

### 3. Class A Metal Chimney

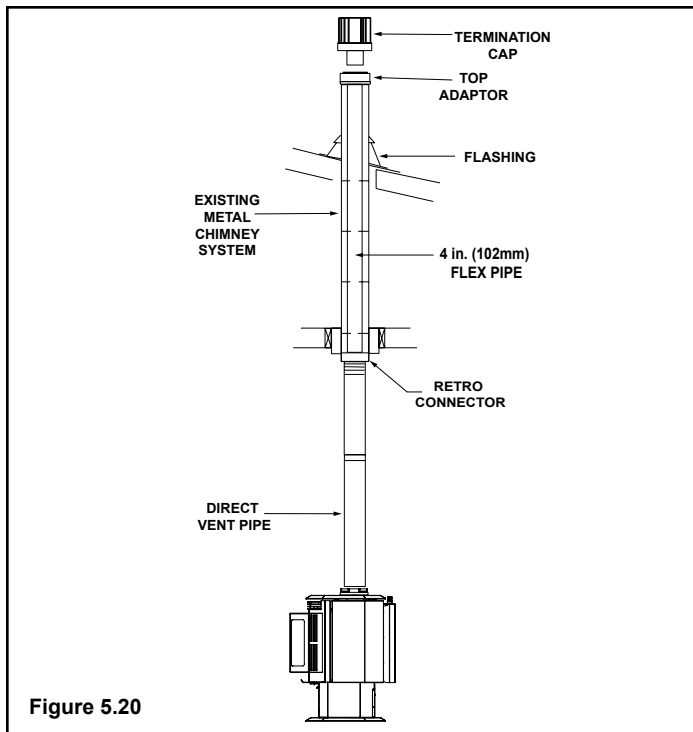

Figure 5.20



### CAUTION

Ensure that existing chimney is functionally sound and clean.

- Have inspection done by qualified chimney sweep or professional installer BEFORE converting to direct vent appliance.

#### Step 1.

Remove existing chimney cap.

#### Step 2.

Measure the distance from the top of the chimney to the bottom of the ceiling support box, add 3 in. (76mm) to this measurement, and cut a section of 4 in. (101mm) flex pipe to that length (the flex should be fully extended).

#### Step 3.

Connect the end of the flex pipe section to the underside of the top adaptor, using four sheet metal screws (Figure 5.21).

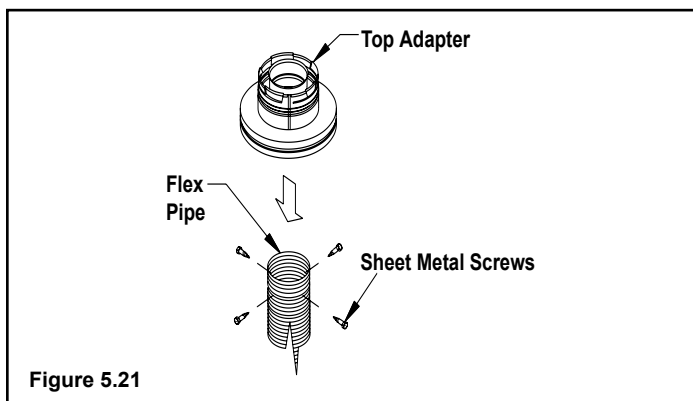

Figure 5.21

#### Step 4.

Pass the flex pipe down through the center of the chimney system, and center the top adaptor on the top of the chimney pipe. Drill four 1/8 in. (3mm) diameter holes through the top adaptor, and into the chimney top. Ensure that you are drilling into the metal on the chimney. Twist lock the high wind termination cap onto the top adaptor (Figures 5.22 and 5.23).

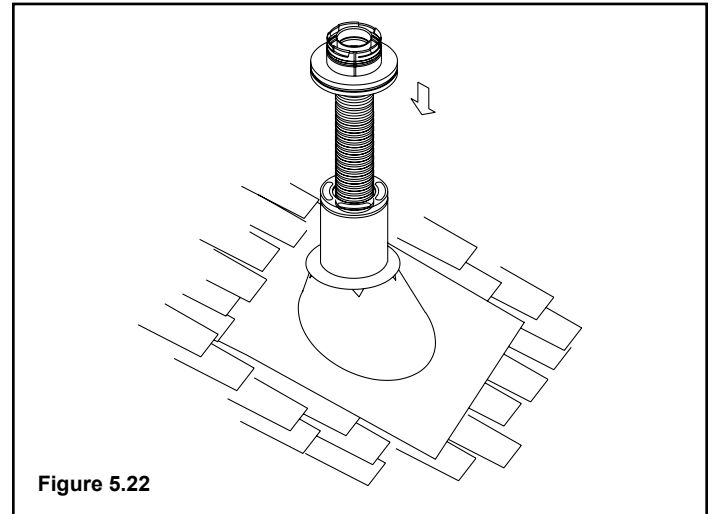

Figure 5.22

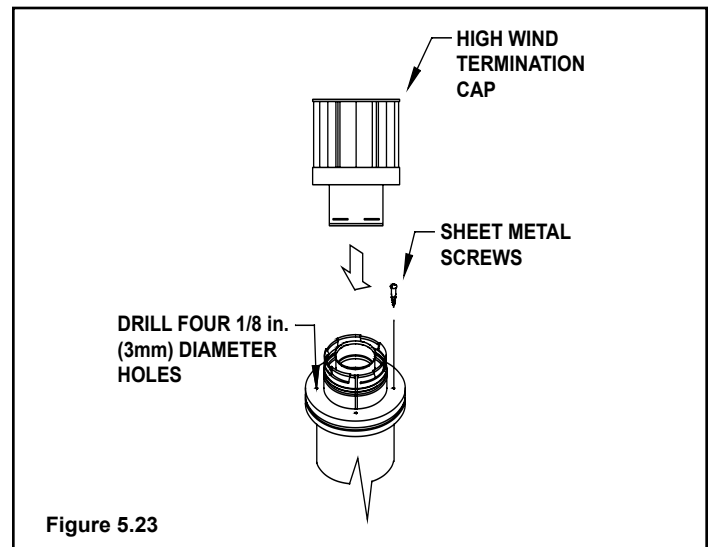

Figure 5.23

#### Step 5.

Pull the flex pipe down through the ceiling support box, until it protrudes approximately 3 in. (76mm). Connect the flex pipe to the retro connector, and attach with sheet metal screws.

#### Step 6.

Push the flex pipe back up into the ceiling support box, center the retro connector, and attach it to the support box with sheet metal screws.

#### Step 7.

The connection between the appliance and the retro connector may be completed with sections of direct vent pipe.

## 4. Existing Masonry Chimney

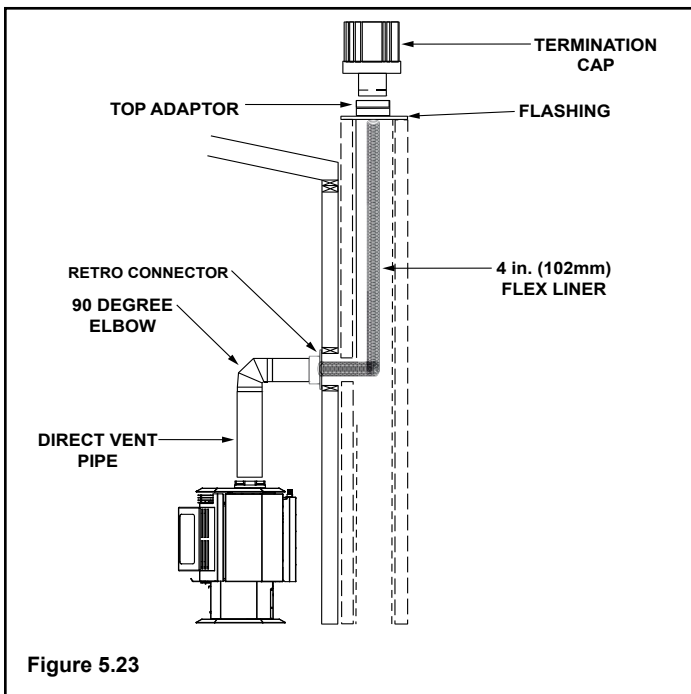

Figure 5.23



### CAUTION

Ensure that existing chimney is functionally sound and clean.

- Have inspection done by qualified chimney sweep or professional installer BEFORE converting to direct vent appliance.

#### Step 1.

Before cutting any holes, assemble the desired sections of direct vent pipe to determine the center of the masonry penetration.

#### Step 2.

Once the center point of the penetration has been determined, cut a 6 in. (152mm) diameter hole in the masonry. If the hole is too large, the retro connector might not mount properly; if the hole is too small, the appliance might starve for intake air. If there is a frame wall in front of the masonry wall, cut and frame a 10 in. (254mm) square opening in the wall (centered around the 6 in. (152mm) masonry opening). If there is sheet rock only (no studs) in front of the masonry the 10 in. (254mm) opening is still needed, but does not need to be framed. If the hole is framed a wall thimble is required. This allows the retro connector to mount directly on the masonry and provide the correct clearances to combustibles (Figure 5.25).

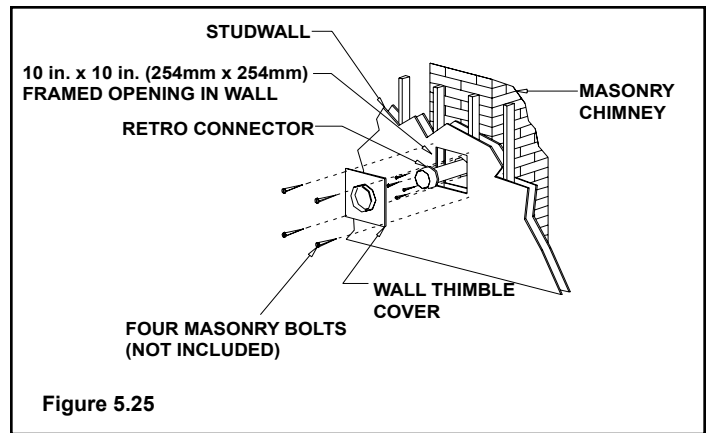

Figure 5.25

#### Step 3.

Secure the flashing to the top of the masonry chimney using a bead of non-hardening sealant-adhesive. If the flashing is larger than the top of the chimney, cut and fold flashing as needed to fit chimney (Figure 5.26).

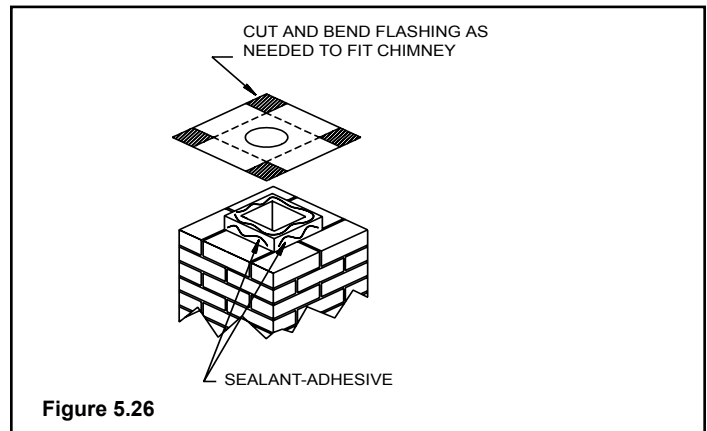

Figure 5.26

#### Step 4.

To determine the length of flex needed, measure from 3 in. (76mm) above the top of the flashing down to the level of the opening. Add the distance from the center of the chimney out through the wall. Cut a piece of 4 in. (102mm) flex to this length (extended to its nominal length). Be sure to leave 2-3 in. (51-76mm) of flex above the existing chimney to allow for connection to the termination kit.

#### Step 5.

Connect the flex liner to the top adaptor using three sheet metal screws (Figure 5.21, page 19).

#### Step 6.

Feed the flex liner through the flashing into the chimney. Carefully feed the flex liner down the chimney to the bottom and out the opening in the masonry wall, forming an angle to line up the flex liner with the vent opening on the appliance.



## WARNING



Fire Risk.

Explosion Risk.

- Do not let the flex liner sag below the level at which it will connect to the appliance or connector. This could allow hot gas to become trapped and potentially become a fire hazard. The flex liner path should always be sloped up toward the termination cap.

### Step 7.

If additional lengths of flex liner are needed to span the chimney height, use a flex coupler to connect the pieces of flex liner together. Connect the flex to the coupler by using four sheet metal screws for each side (**Figure 5.27**).

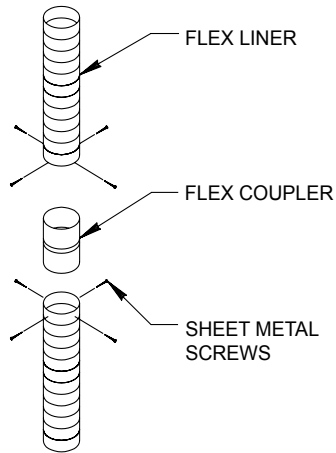

Figure 5.27

### Step 8.

Secure the top adaptor to the flashing. Use three sheet metal screws through the side of the top adaptor into the flange on the flashing (**Figure 5.28**). Twist lock the high wind termination cap on to the top adaptor.

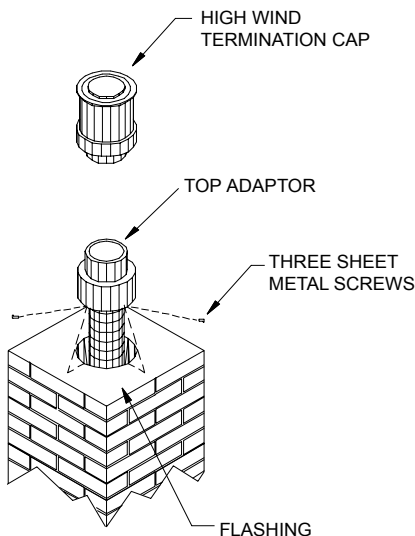

Figure 5.28

### Step 9.

Attach the flex to the retro connector. Use three sheet metal screws to attach the flex liner to the connector (**Figure 5.29**). Mount the retro connector to the masonry wall using masonry bolts. Redrill larger holes on connector as needed. Be careful to ensure that the connector is centered in the opening and the mounting holes line up with the masonry wall.

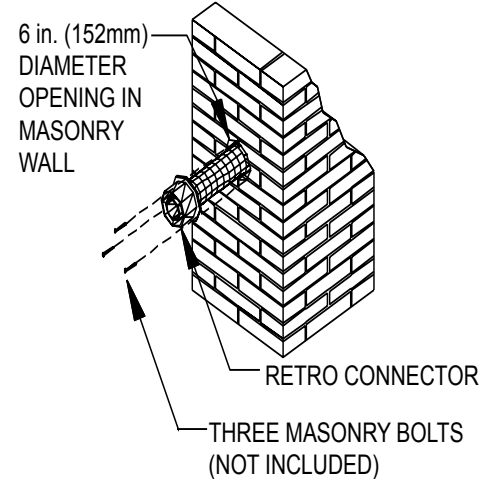

Figure 5.29

### Step 10.

Slide wall thimble cover over retro connector and secure with masonry bolts (**Figure 5.30**). If you have a framed wall in front of the masonry, use wood screws to mount wall thimble cover to framed wall, over retro connector and 10 in. (254mm) square framed opening (**Figure 5.25**, page 20). If needed, add a section of direct vent pipe to the retro connector in order to extend through the opening in the wall thimble cover.

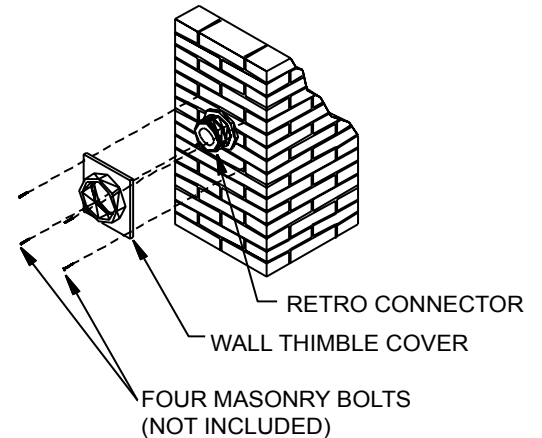

Figure 5.30

### Step 11.

The connection between the appliance and the retro connector may be completed with sections of direct vent pipe.

# 6 Gas Information

## A. Fuel Conversions

Before making gas connections ensure that the appliance being installed is compatible with the available gas type.

Any natural or propane gas conversions necessary to meet the appliance and locality needs must be made by a qualified technician using Hearth & Home Technologies specified and approved parts.

### 1. Converting to LP Gas

**NOTE:** Gas conversions should only be performed by a qualified service person, and/or where required by state and local codes, licensed installer/service technician. In the Commonwealth of Massachusetts, installation must be performed by a licensed plumber or gas fitter.

**KIT CONTENTS:** Replacement orifice; replacement pilot injector; and valve regulator.

**TOOLS REQUIRED:** Ratchet with 7/16 in. socket and 2 in. - 4 in. extension; power drill (a 90° handle is helpful); #2 Phillips bit; 5/32 in. allen wrench; 5/8 in. open end wrench.

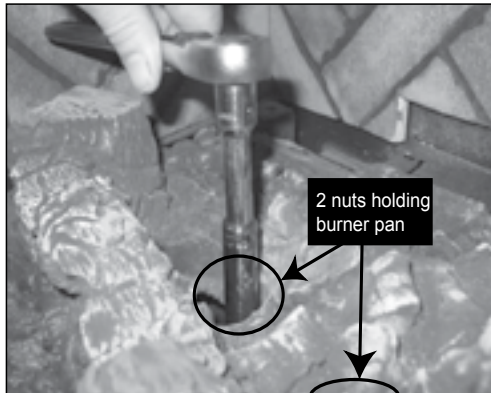

**Figure 6.1** Remove right and left twigs and right and left rear logs from the burner pan, if installed. Remove the 2 nuts that secure the burner pan to the burner support with the ratchet and socket.



**Figure 6.2** - Lift burner up and out of the firebox opening.

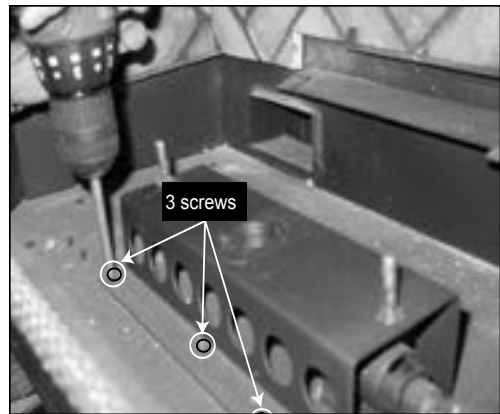

**Figure 6.3** - Remove the three screws on the front of the burner support. Set screws aside.

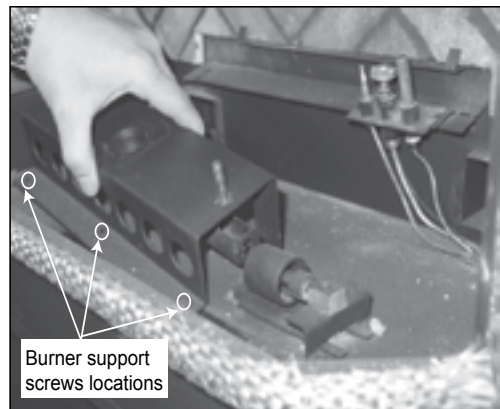

**Figure 6.4** - Slide the burner support to the left to access the orifice.

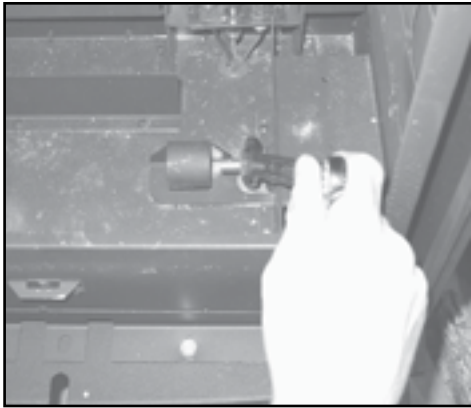

**Figure 6.5** - With a 5/8 in. wrench remove the orifice retaining nut. Replace with appropriate orifice. (.076 LP / .125 NG)

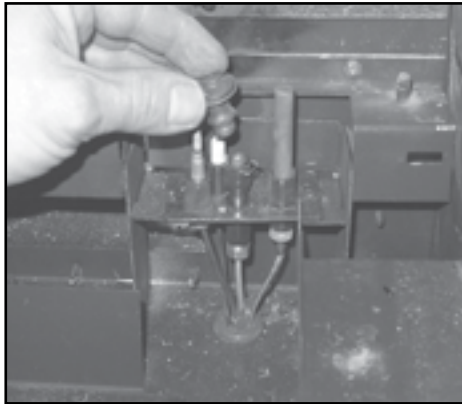

**Figure 6.6** - Remove pilot hood and set aside.  
**NOTE:** Do not remove retaining clip from pilot hood.

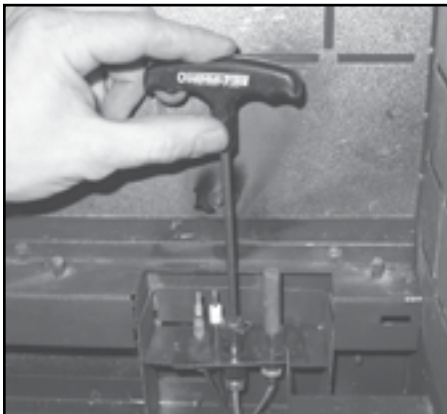

**Figure 6.7** - Using a 5/32 in. allen head wrench, remove pilot injector and replace with an appropriate injector. (#35 LP / #62 NG)

**NOTE:** If installing brick also, do so now before reassembling. If not installing brick, reassemble burner in reverse order.

## 2. Valve Regulator Replacement

### **WARNING**



Fire Risk.

Explosion Risk.

- Disconnect any electrical cords and turn off gas supply to unit before proceeding if converting fuel on an appliance already fully installed.



Remove upper and lower back shield. Loosen the set collars on the extension rods with the 3/32 in. Allen wrench. Remove the rods and adapter cap.

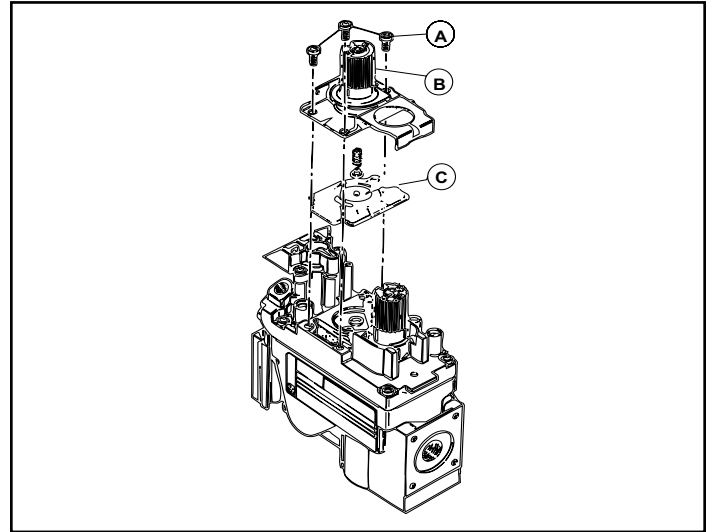

**Figure 6.8** - Turn control knob to the OFF position, ensure that gas supply to the valve has been turned off. Using a Torx TH20, or slotted screwdriver, remove the three pressure regulator mounting screws (A), pressure regulator tower (B), and diaphragm (C).

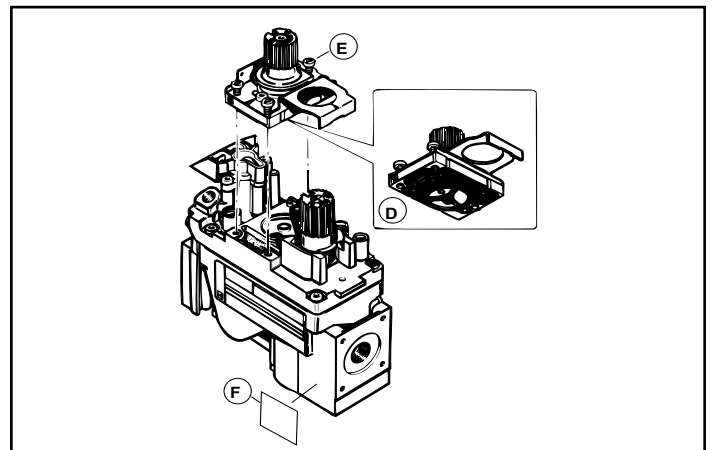

**Figure 6.9** - Ensure that the rubber gasket (D) is properly positioned and install the new HI/LO pressure regulator assembly to the valve using the new screws (E) supplied with the kit. Tighten screws securely. (Reference torque = 25 in./lb.) Install the enclosed identification label (F) to the valve body where it can be seen.

Fill out the conversion label and attach it to the valve cover.

 **WARNING**



Fire Risk.  
Explosion Risk.  
Gas Leak Risk.



- Rubber gasket must be seated properly on valve face.
- Do not install a valve or regulator that has been dropped.

 **WARNING**



Fire Risk.  
Explosion Risk.



- If the information in these instructions is not followed exactly, a fire, explosion or production of carbon monoxide may result causing property damage, personal injury or loss of life.
- The qualified service agency is responsible for the proper installation of this conversion kit. The installation is not proper and complete until the operation of the converted appliance is checked as specified in the manufacturer's instructions supplied with the kit.

## B. Gas Pressures

Proper input pressures required for optimum appliance performance, gas line sizing requirements need to be followed from NFPA54.

 **WARNING**



Fire Risk.  
Explosion Hazard.  
High pressure will damage valve.



- Disconnect gas supply piping BEFORE pressure testing gas line at test pressures above 1/2 psig.
- Close the manual shutoff valve BEFORE pressure testing gas line at test pressures equal to or less than 1/2 psig.

 **WARNING**



Verify inlet pressures.

- High pressure may cause overfire condition.
- Low pressure may cause explosion.



Install regulator upstream of valve if line pressure is greater than 1/2 psig.

Pressure requirements for appliance are shown in the table below.

<b>PRESSURE</b>	<b>NG</b>	<b>LP</b>
Minimum Inlet Pressure	4.5 inches w.c.	11.0 inches w.c.
Maximum Inlet Pressure	7.0 inches w.c.	14.0 inches w.c.
Manifold Pressure on "HI"	3.5 inches w.c.	10.0 inches w.c.

If the pressure is not sufficient, ensure:

1. The piping used is large enough.
2. The supply regulator is adequately adjusted.
3. That the total gas load for the residence does not exceed the amount supplied.

The supply regulator (the regulator that attaches directly to the residence inlet or to the propane tank) should supply gas at the suggested input pressure listed above. Contact the local gas supplier if the regulator is at an improper pressure.



## C. Gas Connection

**NOTE:** Have the gas supply line installed in accordance with local building codes, if any. If not, follow ANSI Z223.1. Installation should be done by a qualified installer approved and/or licensed as required by the locality. (In the Commonwealth of Massachusetts, installation must be performed by a licensed plumber or gas fitter.)

**NOTE:** A listed (and Commonwealth of Massachusetts approved) 1/2 inch (13mm) T-handle manual shut-off valve and flexible gas connector are connected to the 1/2 inch (13mm) control valve inlet.

- **If substituting for these components, please consult local codes for compliance.**

### WARNING



Gas Leak Risk.

- Support control when attaching pipe to prevent bending gas line.

**NOTE:** The gap between the supply piping and gas access hole may be plugged with non-combustible insulation to prevent cold air infiltration.

Leak test all gas line joints and the gas control valve prior to and after starting the fireplace.

Before making the gas connection, ensure that the appliance you are installing is designed for the type of gas being supplied. This information can be found on the Ratings Label under the appliance. If the appliance has been converted to propane (LP), the valve cover should have a label stating that the unit has been converted to propane.

Connect the gas line at the 3/8 in. (9.5mm) pipe connector on the valve at the back of appliance. We recommend connecting the appliance with an approved flex gas line. If flex gas lines are not approved in your area, you must connect a hard pipe to the gas hookup.

You must supply a manual shut-off valve in a visible location within 3 feet (914mm) of the appliance.

### WARNING



Fire or Explosion Hazard

- Gas build-up during line purge may ignite.
- Purge should be performed by qualified technician.
- Ensure adequate ventilation.
- Ensure there are no ignition sources such as sparks or open flame.



- A small amount of air will be in the gas supply lines. When first lighting appliance it will take a short time for air to purge from lines. When purging is complete the appliance will light and operate normally.

Air only needs to be purged again if gas valve has been turned to the OFF position.

### WARNING



CHECK FOR GAS LEAKS

Explosion Risk

Fire Risk

Asphyxiation Risk

- Check all fittings and connections.
- Do not use open flame.
- After the gas line installation is complete, all connections must be tightened and checked for leaks with a commercially-available, non-corrosive leak check solution. Be sure to rinse off all leak check solution following testing.

Fittings and connections may have loosened during shipping and handling.



### WARNING



Fire hazard.

Do NOT change the valve settings.

- This valve has been preset at the factory.
- Changing valve settings may result in fire hazard or bodily injury.

Omni-Test Laboratories listed gas appliances are tested and approved without requiring changes for elevations from 0 to 2000 feet in the U.S.A. and 0 to 4500 feet in Canada.

When installing this appliance at an elevation above 2000 feet, it may be necessary to decrease the input rating by changing the existing burner orifice to a smaller size. Input rate should be reduced by 4% for each 1000 feet above a 2000 foot elevation in the U.S.A. If the heating value of the gas has been reduced, these rules do not apply. To identify the proper orifice size, check with the local gas utility.

If installing this appliance at an elevation above 4500 feet (in Canada), check with local authorities.

# 7 Electrical Information

## A. Recommendation for Wire

See B5 below for recommended maximum lead length (two wire) when using wall thermostat/switch.

**NOTE:** This appliance must be electrically wired and grounded in accordance with local codes or, in the absence of local codes, with **National Electric Code ANSI/NFPA 70-latest edition** or the **Canadian Electric Code, CSA C221.1**.

- A 110-120 VAC circuit for this product must be protected with ground-fault circuit-interrupter protection, in compliance with the applicable electrical codes, when it is installed in locations such as in bathrooms or near sinks.

## B. Connecting to the Appliance

**WARNING**



Wire 110v to electrical junction box.  
Do NOT wire 110v to the valve.  
Do NOT wire 110V to wall switch.

- Incorrect wiring will damage millivolt systems.



1. This appliance may be used with a wall switch, wall mounted thermostat and / or a remote control.
2. If using thermostat, use one compatible with a millivolt gas valve system.
3. Follow parameters for locating thermostat (see individual thermostat instructions) to ensure proper operation of appliance.
4. Use low resistance thermostat wire for wiring from ignition system to the wall switch and thermostat.
5. Use the following chart for wire sizing.

Wire Size	Max. Length
16 gauge	65 feet
18 gauge	40 feet
20 gauge	25 feet
22 gauge	18 feet

6. Keep wire lengths as short as possible by removing any excess wire length.
7. Low voltage and 110 VAC voltage cannot be shared within the same wall box.

8. Ensure the thermostat is mounted level for accurate readings.
9. The thermostat should be mounted on an inside wall and not in direct line with the appliance convection air.
10. If the thermostat is located too close to the appliance, you may need to set the temperature setting slightly higher to maintain the desired temperature in your home.

**Do not connect this appliance to a thermostat serving any other appliance.**

**Bedroom installation in Canada requires this appliance to be connected to a thermostat.**

**WARNING**



Shock hazard.

- This appliance is equipped with a three pronged (grounding) plug for your protection against shock hazard and should be plugged directly into a properly grounded three prong receptacle. Do not cut or remove the grounding prong from this plug.

## C. Standing Pilot Ignition System Wiring

This appliance **DOES NOT** require 110 VAC supply for operation. A wiring diagram is shown in **Figure 7.1** on the next page.

This appliance is equipped with a millivolt control valve.

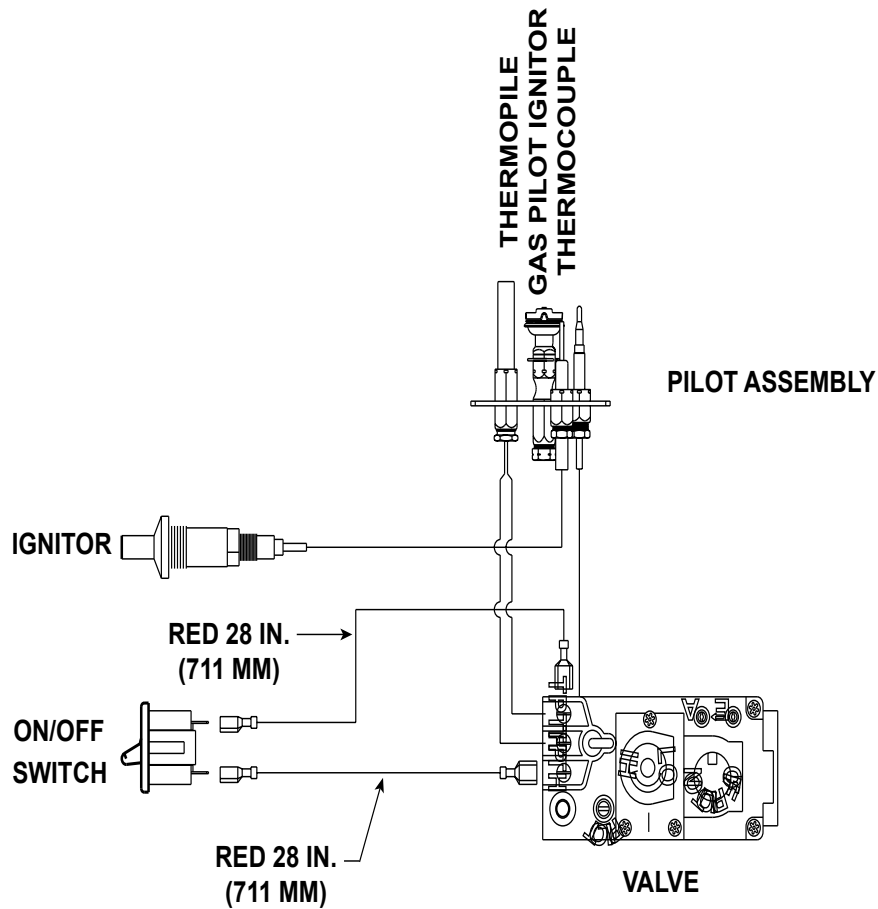

Figure 7.1

**⚠ CAUTION**

Label all wires prior to disconnection when servicing controls. Wiring errors can cause improper and dangerous operation. Verify proper operation after servicing.

**⚠ CAUTION**



Shock hazard.

- Replace damaged wire with type 105° C rated wire.
- Wire must have high temperature insulation.

# 8 Appliance Set-Up

## A. Remove Shipping Materials

Remove shipping materials from inside or underneath the firebox.

## B. Accessories

Install approved accessories per instructions included with accessories.

## C. Front Door Assembly / Installation

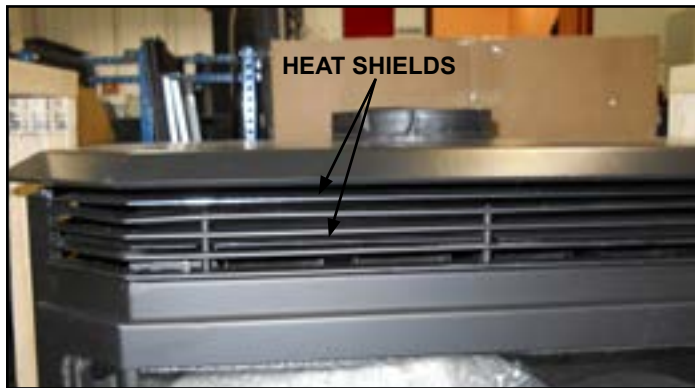

Figure 8.1 - Before removing the door, notice the location of the interior heat shields between door grille fins. The heat shields will need to remain in these locations when reattaching the door.

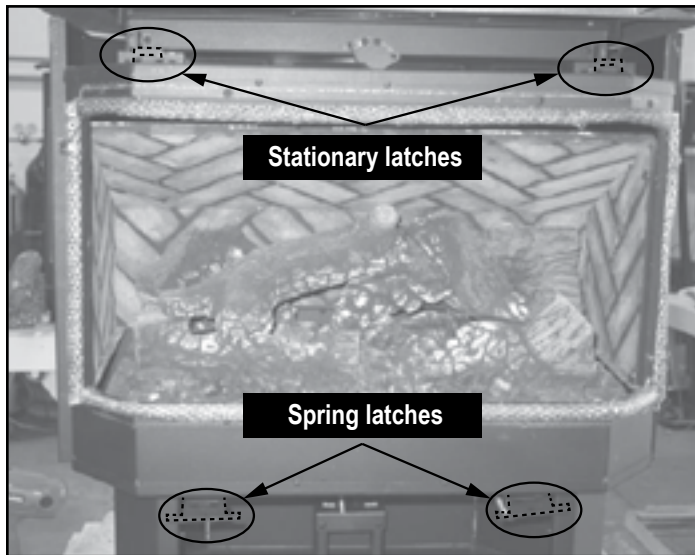

Figure 8.2 - Open lower access panel. Pull out and unhook the two spring latches on the bottom of the appliance that secure the door.

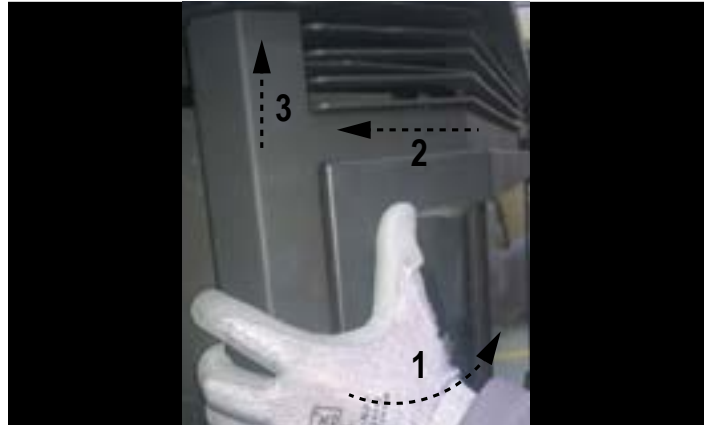

Figure 8.3 - **Step 1** - Pull the bottom of the door forward approximately 1-1/2" (38mm). **Step 2** - Grabbing the door from the sides towards the top of the glass, push in on the top of the door. **Step 3** - Lift up off of the stationary latches and away from the stove, removing the door.



Figure 8.4 - When reassembling the door, be sure to line up the lower shield in the middle grille, line up the grille post with the notches in the lower heat shield. Once shields are lined up (post should be flush with front of shields) push up on the shields using the door and push in to allow the door to rest on the latches. Figure 8.4.



Figure 8.5 - Notice Hook Notch on upper corner of front assembly. Figure 8.5.

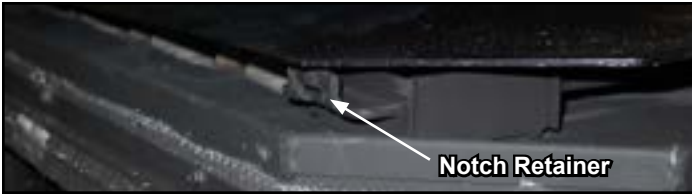

**Figure 8.6** - The notch on the front assembly is hooked on the retainer at the top of the stove. It will be necessary to apply a small amount of force to the top of the front when removing the front from the appliance. When pivoting the front away from the appliance push up and inward to release the hook notches from the notch retainers.

When reassembling the front to the appliance, be sure notches are hooked into the retainers before attempting to attach spring latches at the bottom of the front.

#### D. Door Crown Installation



**Figure 8.7** - Uninstall the existing crown by removing the four screws on the back side of the door. Retain the screws.



**Figure 8.8** - Use a flat-head screwdriver to pry the black crown free on the right side. Remove the crown and discard.



**Figure 8.9** - Carefully align the left side of the crown into place, and wrap it across the face of door, finally snapping it into place on the right hand side. Reinsert and tighten the screws previously removed.

Use a soft cloth and a window cleaning solution to clean all fingerprint oils from the gold or nickel surface of crown **PRIOR** to lighting the appliance.

#### E. Grille Installation

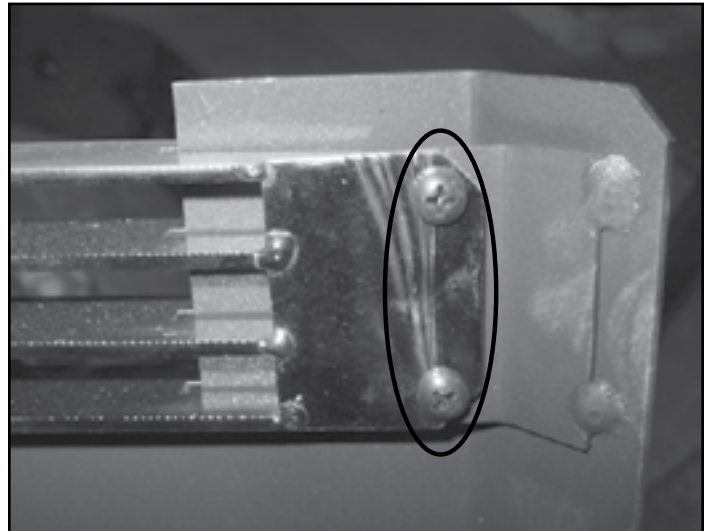

**Figure 8.10** - Following instructions stated above, remove the door of appliance.

Remove the four screws (two at each end) holding the grille in place. Lift up to remove.

Install the new grille by reversing the removal instructions.

**NOTE:** Clean glass and gold or nickel plating with glass cleaner and a soft cloth, wiping off all fingerprints prior to first fire to prevent permanent staining.

## F. Brick Set Installation

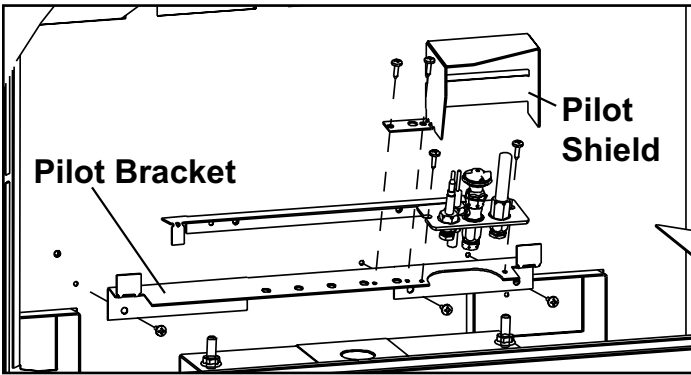

**Figure 8.11** - The pilot shield has to be removed to install or remove the brick refractory. Removal of the bracket requires removing two screws.

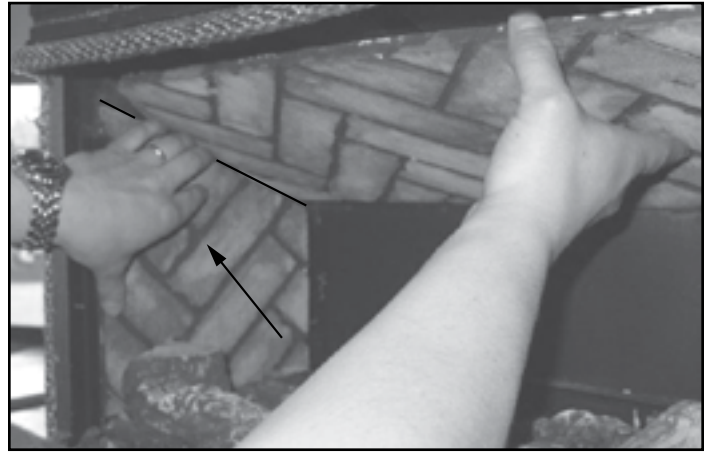

**Figure 8.14** - Still holding the baffle in place, install the left brick into position.

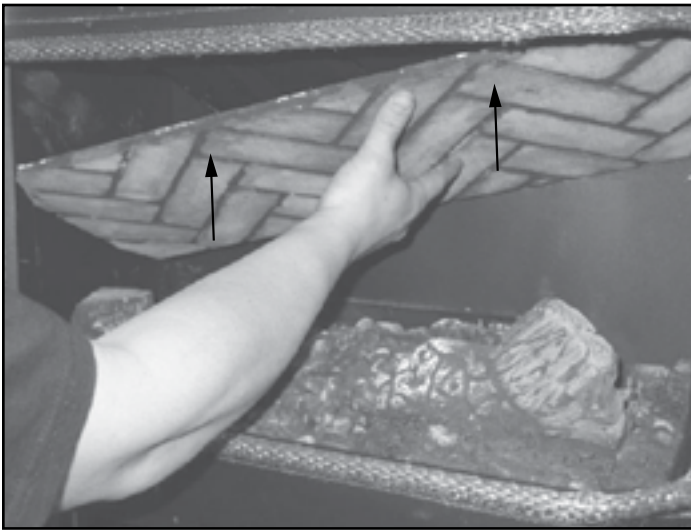

**Figure 8.12** - To install the baffle, slide it in at an angle and rotate upward parallel with the firebox. Place baffle up against the heat exchangers in top of the firebox. Hold against heat exchangers, slide baffle towards front of appliance.

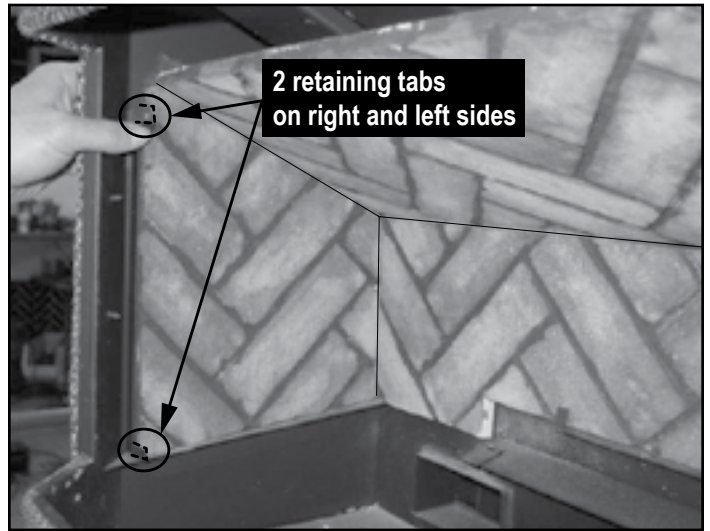

**Figure 8.15** - Bend retaining tabs on the left and right sides inward to hold brick in place.



**Figure 8.13** - Keeping the baffle elevated with your hand, put the right side brick into position. Rest the baffle on the right side brick.

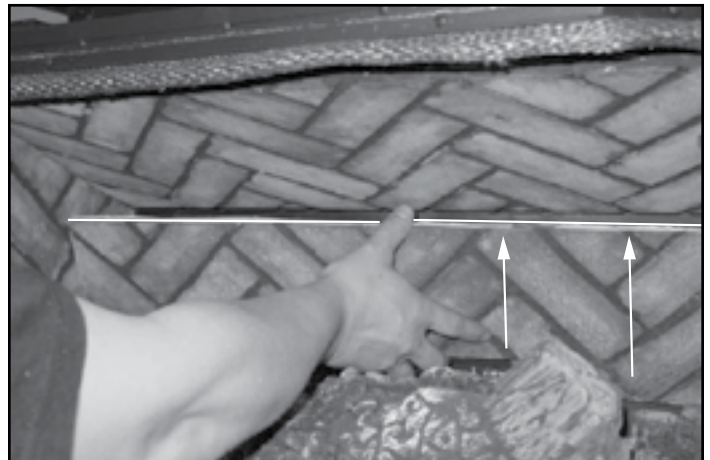

**Figure 8.16** - Install the rear brick. Slide it in at an angle and place over the rear brick retainer. Hand bend retaining tabs up to hold brick in place. Push baffle towards back of firebox.

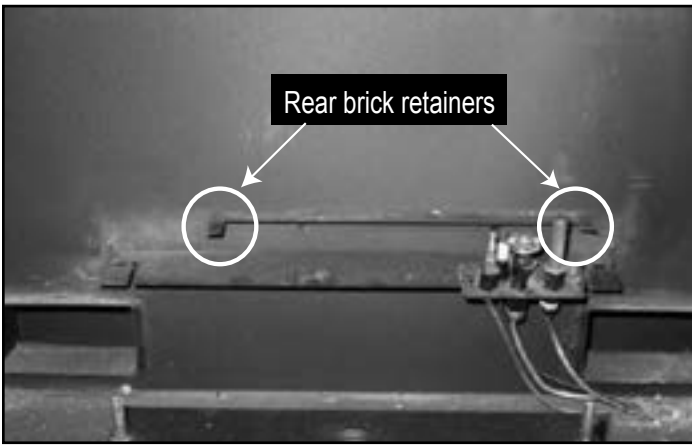

**Figure 8.17 - NOTE:** For the Hudson Bay Free Standing the upper rear brick retainer is used.

Reinstall the pilot shield with the screws removed in **Figure 8.6**. The pilot shield must be in place before operation of appliance.

### G. Positioning the Logs

While still breakable, the logs do not become fragile until after the appliance is burned and they have cured. After curing, any handling must be done with care as breakage can easily occur.

**PLEASE NOTE:** Logs have been designed to work specifically with the burner of this appliance. Exact placement will ensure proper operation of your gas appliance and reduce sooting.



**Figure 8.18 - Log Set**

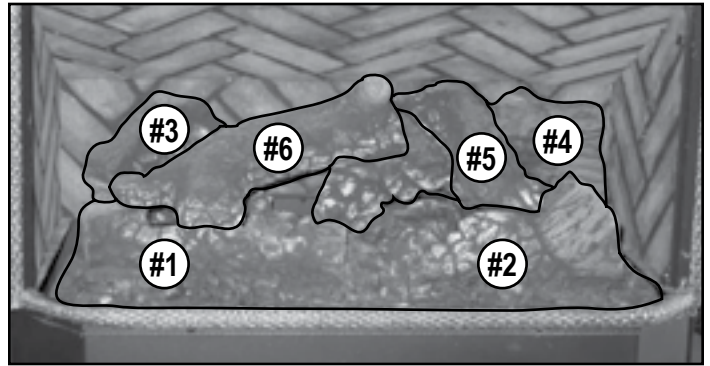

**Figure 8.19 - Logs** shown installed in firebox. Logs #1 and #2 are part of the burner pan and are numbered for reference only.

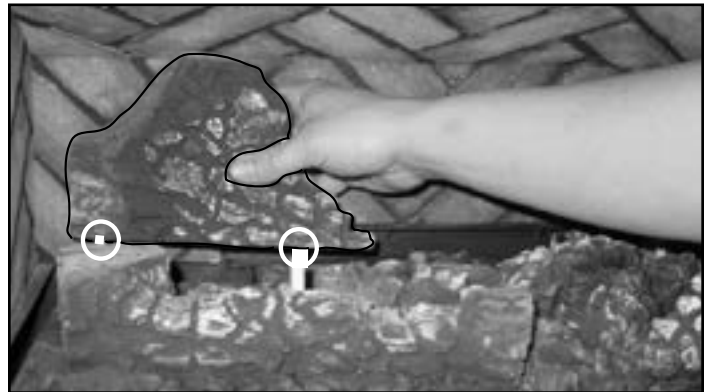

**Figure 8.20 - Install** the left rear log (#3) over the locator pins in the burner pan.

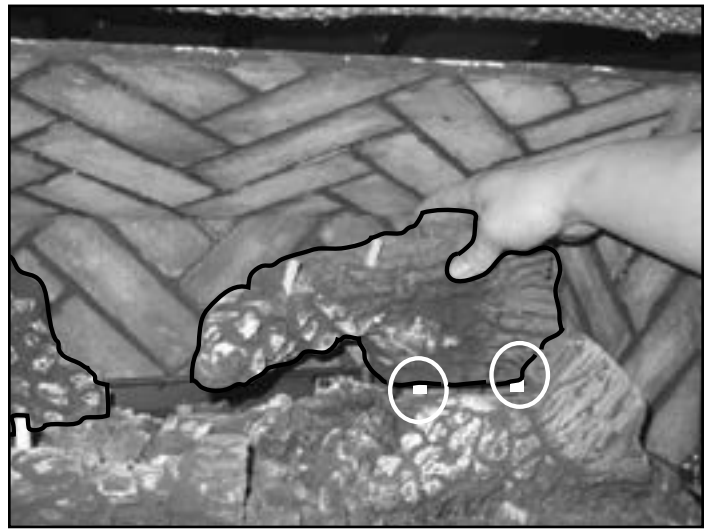

**Figure 8.21 - Install** the right rear log (#4) over the locator pins in the burner pan.

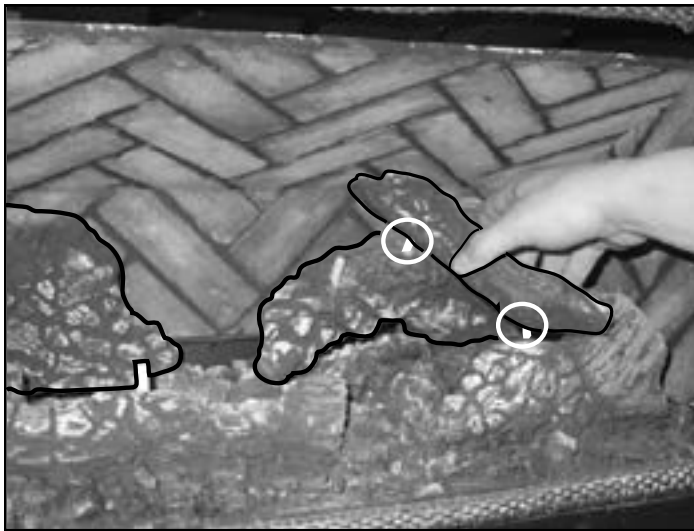

**Figure 8.22** - Install the right twig (#5) over the locator pins in the right rear log and the right front log.



**Figure 8.23** - Install the left twig (#6) over the locator pins in the right rear log and the left front log.

## H. Mineral Wool

### **WARNING**



- Follow ember placement instructions in manual.
- Do NOT place embers directly over burner ports.
- Replace ember material annually.

Improperly placed embers interferes with proper burner operation.

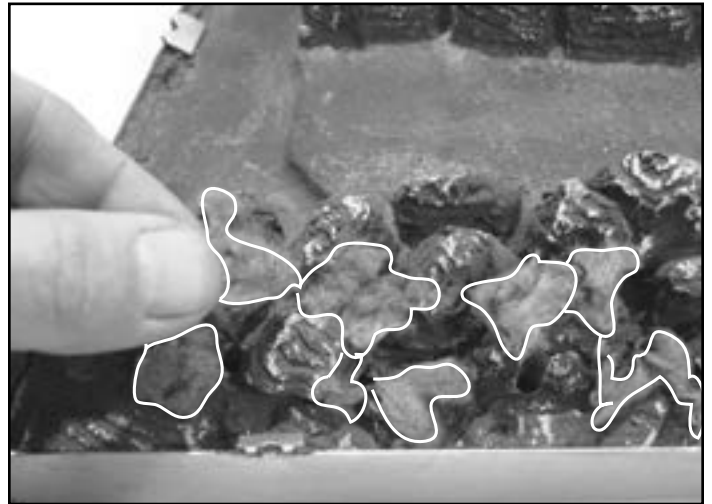

**Figure 8.24** - Place individual pieces of embers in front of and around the gas logs where they can be seen. Space them so that gas can contact them on all sides. Avoid stacking the embers on top of each other.

**NOTE: Do not block gas ports.**



## I. Blower Installation

**KIT CONTENTS:** Blower; 2 female spade wire connectors.

**TOOLS REQUIRED:** Powered screwdriver with a #2 Phillips head bit.

The blower motor comes standard with two male spade wire connectors. If your appliance has a different connection, use the two female spade wire connectors provided to modify the appliance wiring harness.

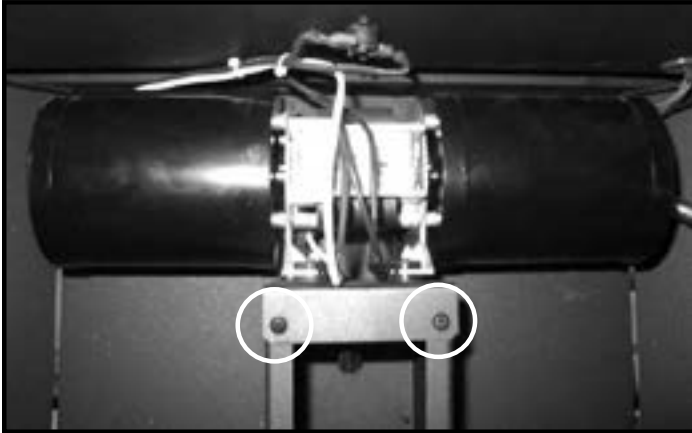

**Figure 8.25** - Disconnect power to the appliance. To access the blower, open the door located on the front of the pedestal. Remove the two screws holding the blower bracket in place.

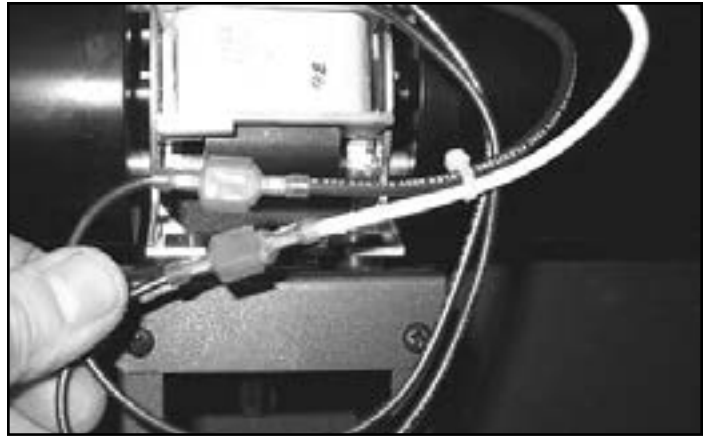

**Figure 8.26** - Disconnect wires to the blower motor. Remove the blower from the bracket.

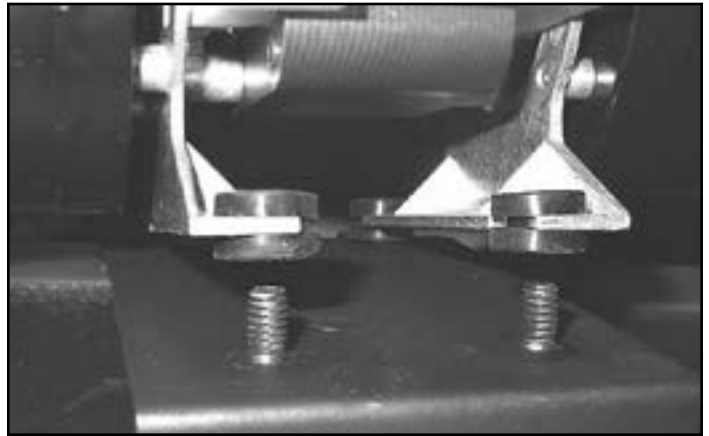

**Figure 8.27** - Install the new blower by slipping grommets over studs on the blower bracket. Reinstall the blower and bracket. Connect the wires. Install screws. Restore power to the appliance.

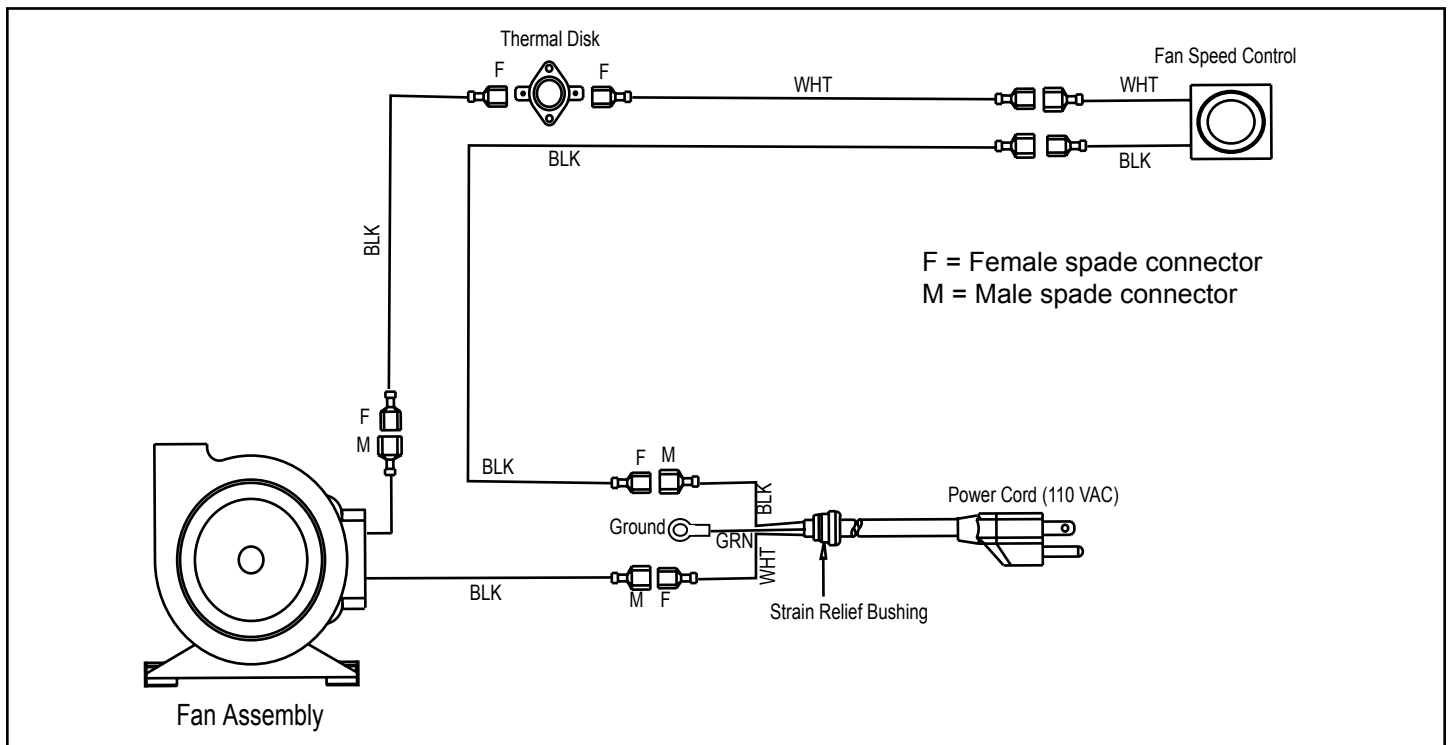

**Figure 8.23** Blower Wiring Diagram

## J. Damper Adjustment

See vent graph for recommendations on page 11 before you begin your adjustment. If your installation falls within the range of the gray shaded area of graph, it may be necessary to make an adjustment to the vertical damper to improve the flame appearance in your appliance.

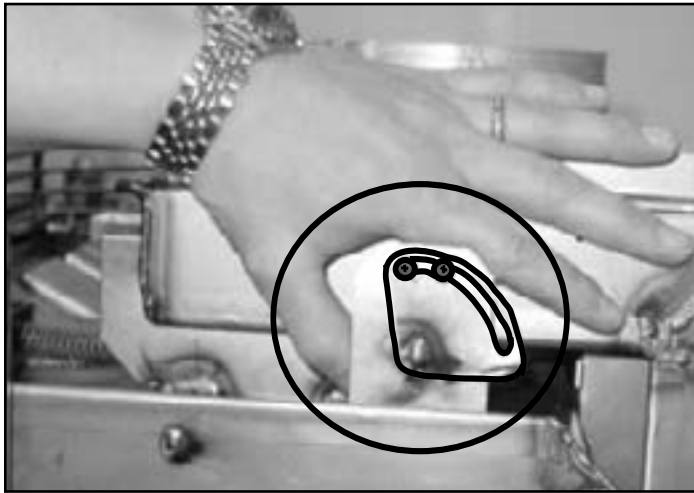
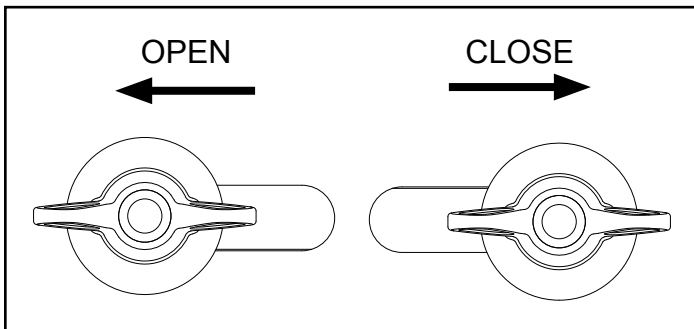

**Figure 8.28** - Open the right side panel to access the damper adjustment.

Loosen screws and make adjustment according to vent chart. Make adjustment until flame size and activity suits your personal preference, and then retighten the screws.

**NOTE:** In the Commonwealth of Massachusetts, the word damper shall be replaced with the words flue restrictor.

## K. Shutter Adjustment



**Figure 8.29** - The shutter is located on the underside of the appliance, on the right side. To adjust the shutter, loosen the wingnut. Retighten the wingnut after adjustment.

Moving the shutter bolt to the right closes the shutter. Moving the shutter bolt to the left, will open the shutter. Opening the shutter causes flames to become shorter and blue. Closing the shutter creates taller orange/yellow flames.

**NOTE:** Shutter is factory set in the fully open position. Do not close so much as to cause a sooty flame. Improper adjustment can cause sooting in the firebox and/or on the outside of a house with a horizontal termination.

After adjustment, tighten nut to lock in place.

Adjustments should only be made by a qualified installer.

## L. Glass Replacement

**NOTE:** Glass can be replaced either as three separate pieces, or as an assembly with the door. See Section 12.



### To Replace Separate Glass Pieces

1. Turn off gas to appliance.
2. Remove safety barrier from appliance by lifting it slightly upward.
3. Remove door from the appliance and set on a protective surface.
4. Remove door crown. See instructions in this manual for installation of door crown for procedure.
5. Remove top and bottom retainer screws from front of door. Set top and bottom glass retainers aside. Loosen side glass retainer screws, but do not remove.
6. Remove glass pieces and discard. Keep aluminum channels for reassembly.
7. Slide replacement side glass into the side glass retainers.
8. Place aluminum channels over side glass.
9. Install center glass into aluminum channels.
10. Reinstall glass retainers and screws.
11. Reinstall door crown.

### Door Frame with Glass Assembly Replacement

Use only Door Assembly replacement as specified in Section 12 of this manual, available from your dealer, if any glass becomes broken in the Hudson Bay.

Follow the previous instructions to install the door crown and grille to the new Door Assembly.

 <b>CAUTION</b>	
	<p>Handle glass assembly with care.</p> <ul style="list-style-type: none"><li>• Inspect the gasket to ensure it is undamaged.</li><li>• Inspect the glass for cracks, chips or scratches.</li><li>• Do NOT strike, slam or scratch glass.</li><li>• Do NOT operate appliance with glass door removed, cracked, broken or scratched.</li><li>• Replace glass assembly as a complete assembly.</li></ul>

## M. Safety Barrier Installation

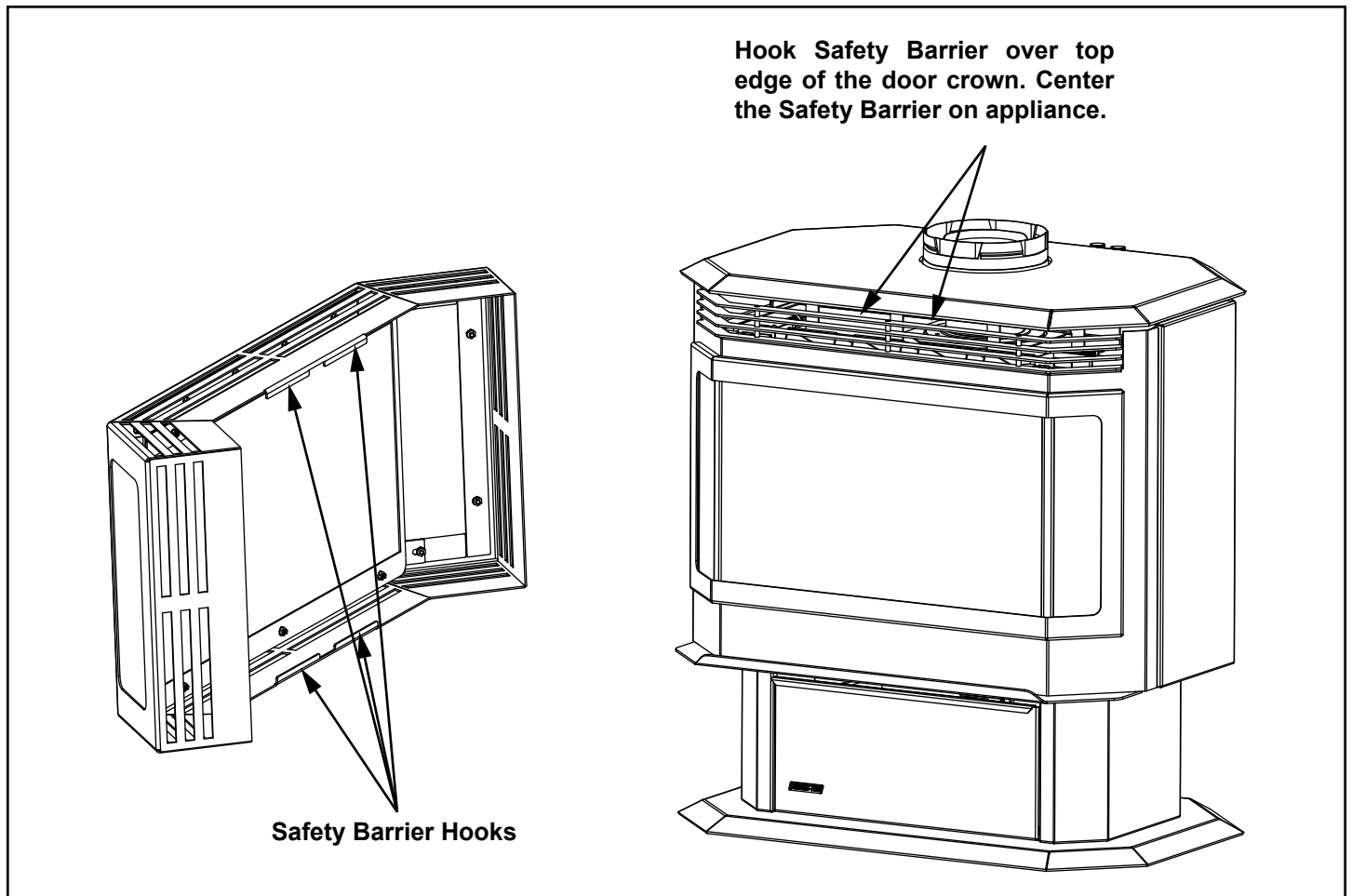





# 9 Operating Instructions

## A. Before Lighting Appliance

Read this entire manual prior to using the appliance. Failure to follow the instructions may result in property damage, bodily injury, or even death.

- Remove all shipping materials from inside and/or underneath the firebox.
- Review proper placement of logs, mineral wool.
- Check the wiring.
- Check the baffle adjustment.
- Ensure that there are no gas leaks.
- Ensure that the glass is sealed and in the proper position.
- Ensure that the flow of combustion and ventilation air is not obstructed (front grilles and vent caps).

 <b>WARNING</b>	
	Glass door must be in place when appliance is operating.
<b>Risk of:</b>	
<ul style="list-style-type: none"><li>• Combustion Fumes</li><li>• Fire</li></ul>	
<b>Do NOT operate appliance with glass door removed.</b>	
	<ul style="list-style-type: none"><li>• Open viewing glass for servicing only.</li><li>• Glass door <b>MUST</b> be in place and sealed before operating appliance.</li><li>• Only use glass door certified for use with appliance.</li><li>• Glass replacement should be done by qualified technician.</li></ul>

 <b>DANGER</b>	
	<b>HOT GLASS WILL CAUSE BURNS. DO NOT TOUCH GLASS UNTIL COOLED. NEVER ALLOW CHILDREN TO TOUCH GLASS.</b>
A barrier designed to reduce the risk of burns from the hot viewing glass is provided with this appliance and shall be installed for the protection of the children and other at-risk individuals.	

 <b>WARNING</b>	
Improper installation, adjustment, alteration, service or maintenance can cause injury or property damage. Refer to the owner's information manual provided with this appliance. For assistance or additional information consult a qualified installer, service agency or the gas supplier.	

 <b>WARNING</b>	
Do NOT use this appliance if any part has been under water. Immediately call a qualified service technician to inspect the appliance and to replace any part of the control system and any gas control which has been under water.	

## B. Controls

**FAN SPEED:** This knob controls the speed of the blower that pushes the heated air into the room.

**MAIN BURNER:** This control is used to turn the appliance on and off.

**PILOT IGNITOR:** The pilot ignitor is used only to start the pilot. When the valve control knob is turned to the pilot position and fully depressed press the piezo ignitor repeatedly creating a blue spark directly next to the pilot, igniting the pilot flame.

**VALVE CONTROL:** This knob is used to control gas to the appliance and for starting the pilot. There are three positions, **ON, OFF, & PILOT**. The indicator on the valve indicates the position of the knob.

**COMFORT CONTROL:** This knob controls the flame height from low ("LO") to high ("HI").

**NOTE:** If using a remote control wall switch, or thermostat, the On/Off Switch must be left "OFF". Turning the On/Off Switch to "ON" will keep the appliance on continually.

 <b>WARNING</b>	
A barrier designed to reduce the risk of burns from the hot viewing glass is provided with this appliance and shall be installed for the protection of children and other at-risk individuals.	
If the barrier becomes damaged, the barrier shall be replaced with the manufacturer's barrier for this appliance.	
Clothing or other flammable material should not be placed on or near the appliance.	
Any safety screen, guard, or barrier removed for servicing an appliance must be replaced prior to operating the appliance.	

## C. Lighting Appliance

### FOR YOUR SAFETY READ BEFORE LIGHTING

**WARNING:** If you do not follow these instructions exactly, a fire or explosion may result causing property damage, personal injury or loss of life.

- A. This appliance is equipped with an intermittent pilot ignition (IPI) device which automatically lights the burner. **DO NOT** try to light the burner by hand.
- B. **BEFORE LIGHTING**, smell all around the appliance area for gas. Be sure to smell next to the floor because some gas is heavier than air and will settle on the floor.
- WHAT TO DO IF YOU SMELL GAS**
- **DO NOT** try to light any appliance.
  - **DO NOT** touch any electric switch; do not use any phone in your building.
  - Immediately call your gas supplier from a neighbor's phone. Follow the gas supplier's instructions.
  - If you cannot reach your gas supplier, call the fire department.
- C. Use only your hand to push in or turn the gas control knob. Never use Tools. If the knob will not push in or turn by hand, **DO NOT** try to repair it, call a qualified service technician. Force or attempted repair may result in a fire or explosion.
- D. **DO NOT** use this appliance if any part has been under water. Immediately call a qualified service technician to inspect the appliance and to replace any part of the control system and any gas control which has been under water.

### LIGHTING INSTRUCTIONS (IPI)

1. This appliance is equipped with an ignition device which automatically lights the burner. **DO NOT** try to light the burner by hand.
2. Wait five (5) minutes to clear out any gas. Then smell for gas, including near the floor. If you smell gas, **STOP!** Follow "B" in the Safety Information located on the left side of this label. If you do not smell gas, go to next step.
3. To light the burner:  
Equipped with wall switch: Turn ON/OFF switch to ON.  
Equipped with remote or wall control: Press ON or FLAME button.  
Equipped with thermostat: Set temperature to desired setting.
4. If the appliance does not light after three tries, call your service technician or gas supplier.

**GAS VALVE**

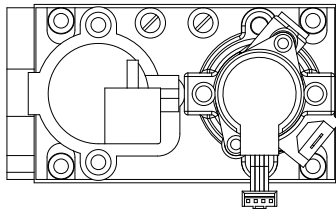

### TO TURN OFF GAS TO APPLIANCE

1. Equipped with wall switch: Turn ON/OFF switch to OFF.  
Equipped with remote or wall control: Press OFF button.  
Equipped with thermostat: Set temperature to lowest setting.
2. Service technician should turn off electric power to the control when performing service.



# DANGER



**HOT GLASS WILL CAUSE BURNS.  
DO NOT TOUCH GLASS UNTIL COOLED.  
NEVER ALLOW CHILDREN TO TOUCH GLASS.**

A barrier designed to reduce the risk of burns from the hot viewing glass is provided with this appliance and shall be installed for the protection of children and other at-risk individuals.

### WARNING:

**DO NOT CONNECT LINE VOLTAGE (110/120 VAC OR 220/240 VAC) TO THE CONTROL VALVE.**

Improper installation, adjustment, alteration, service or maintenance can cause injury or property damage. Refer to the owner's information manual provided with this appliance.

This appliance needs fresh air for safe operation and must be installed so there are provisions for adequate combustion and ventilation air.

If not installed, operated, and maintained in accordance with the manufacturer's instructions, this product could expose you to substances in fuel or fuel combustion which are known to the State of California to cause cancer, birth defects, or other reproductive harm.

Keep burner and control compartment clean. See installation and operating instructions accompanying appliance.

### CAUTION:

Hot while in operation. **DO NOT** touch. Keep children, clothing, furniture, gasoline and other liquids having flammable vapors away.

**DO NOT** operate the appliance with fixed glass assembly removed, cracked or broken. Replacement of the fixed glass assembly should be done by a licensed or qualified service person.

### NOT FOR USE WITH SOLID FUEL

For use with natural gas and propane. A conversion kit, as supplied by the manufacturer, shall be used to convert this appliance to the alternate fuel.

**Also Certified for Installation in a Bedroom or a Bedsitting Room.**

For assistance or additional information, consult a qualified installer, service agency or the gas supplier.

For additional information on operating your  
Hearth & Home Technologies fireplace, please refer to [www.fireplaces.com](http://www.fireplaces.com).

593-913i



## D. After Appliance is Lit

### Initial Break-in Procedure

When you light your appliance, you may notice that it produces heat which does have an associated odor or smell. If you feel this odor is excessive it may require the initial three to four hour continuous burn on high followed by a second burn up to 12 hours to fully drive off any odor from paint and lubricants used in the manufacturing process. Condensation on the glass is normal.



**NOTE:** The appliance should be run three to four hours on the initial start-up. Turn it off and let it cool completely. Remove and clean the glass. Replace the glass and run the appliance for an additional 12 hours. This will help to cure the products used in the paint and logs.

During this break-in period it is recommended that some windows in the house be opened for air circulation. This will help avoid setting off smoke detectors, and help eliminate any odors associated with the appliance's initial burning.

 <b>WARNING</b>	
	<p><b>Fire Risk.</b> <b>High Temperatures.</b> <b>Keep combustible household items away from appliance.</b></p> <p><b>Do NOT obstruct combustion and ventilation air.</b></p> <ul style="list-style-type: none"> <li>• <b>Do NOT place combustible items on top of or in front of appliance.</b></li> <li>• <b>Keep furniture, draperies away from appliance.</b></li> </ul>

 <b>CAUTION</b>	
<ul style="list-style-type: none"> <li>• Prevent accidental appliance operation when not attended.</li> <li>• Unplug or remove batteries from remote control if absent or if appliance will not be used for an extended period of time.</li> <li>• Property damage possible from elevated temperatures.</li> </ul>	

 <b>CAUTION</b>	
<p>Smoke and odors released during initial operation.</p> <ul style="list-style-type: none"> <li>• Open windows for air circulation.</li> <li>• Leave room during initial operation.</li> <li>• Smoke may set off smoke detectors.</li> </ul> <p>Smoke and odors may be irritating to sensitive individuals.</p>	

 <b>WARNING</b>	
	<p><b>Fire Hazard.</b> <b>Keep combustible materials, gasoline and other flammable vapors and liquids clear of appliance.</b></p> <ul style="list-style-type: none"> <li>• <b>Do NOT store flammable materials in the appliance's vicinity.</b></li> <li>• <b>Do NOT use gasoline, lantern fuel, kerosene, charcoal lighter fluid or similar liquids in this appliance.</b></li> <li>• <b>Combustible materials may ignite.</b></li> </ul>

## E. Frequently Asked Questions

ISSUE	SOLUTIONS
Condensation on the glass	This is a result of gas combustion and temperature variations. As the appliance warms, this condensation will disappear.
Blue flames	This is a result of normal operation and the flames will begin to yellow as the appliance is allowed to burn for 20 to 40 minutes.
Odor from appliance	When first operated, this appliance may release an odor for the first several hours. This is caused by the curing of the paint and the burning off of any oils remaining from manufacturing. If appliance has not been used for some time, dust can build up and cause an odor.
Film on the glass	This is a normal result of the curing process of the paint and logs. Glass should be cleaned within 3 to 4 hours of initial burning to remove deposits left by oils from the manufacturing process. A non-abrasive cleaner such as gas appliance cleaner may be necessary. See your dealer.
Metallic noise	Noise is caused by metal expanding and contracting as it heats up and cools down, similar to the sound produced by a furnace or heating duct. This noise does not affect the operation or longevity of the appliance.

# 10 Troubleshooting

With proper installation, operation, and maintenance your gas appliance will provide years of trouble-free service. If you do experience a problem, this troubleshooting guide will assist a qualified service person in the diagnosis of a problem and the corrective action to be taken. This troubleshooting guide can only be used by a qualified service technician.

Symptom	Possible Cause	Corrective Action
1. After repeated triggering of the piezo button, the spark ignitor will not light the pilot.	a. Defective ignitor.	Check the spark at the electrode and pilot. If no spark and electrode wire is properly connected, replace the ignitor.
	b. Defective pilot or misaligned electrode (spark at electrode).	Using a match, light the pilot. If the pilot lights, turn off the pilot and trigger the piezo button again. If the pilot lights, an improper gas/air mixture caused the bad lighting and a longer purge period is recommended. If the pilot will not light, ensure the gap at the electrode and pilot is one-eighth (1/8) inch to have a strong spark. If the gas is OK, replace the pilot.
	c. No gas or low gas pressure.	Check the remote shut-off valve from the appliance. Usually, there is a valve near the gas main. There can be more than one (1) valve from the appliance and the main.
	d. No LP in tank.	Check the LP (propane) tank. You may be out of fuel.
2. The pilot will not stay lit after carefully following the lighting instructions.	a. Defective thermocouple.	<p>Check that the pilot flame impinges on the thermocouple. Clean and /or adjust the pilot for maximum flame impingement.</p> <p>Ensure that the thermocouple connection at the gas valve is fully inserted and tight (hand tighten plus 1/4 turn).</p> <p>Disconnect the thermocouple from the valve, place one millivolt lead wire on the tip of the thermocouple and the other meter wire on the thermocouple copper lead. Start the pilot and hold the valve knob in. If the millivolt reading is less than 15mV, replace the thermocouple.</p>
	b. Defective valve.	If the thermocouple is producing more than 15 millivolts, replace faulty valve.
3. The pilot is burning, there is no gas to the burner, the valve knob is in the ON position, and the ON/OFF switch is in the ON position.	a. ON/OFF switch or wires defective.	Check the ON/OFF switch and wires for proper connections. Place the jumper wires across the terminals at the switch. If the burner comes on, replace the defective switch. If the switch is OK, place the jumper wires across the switch wires at the gas valve. IF the burner comes on, the wires are faulty or connections are bad.
	b. Thermopile may not be generating sufficient millivolts.	<p>If the pilot flame is not close enough physically to the thermopile, adjust the pilot flame.</p> <p>Be sure the wire connections from the thermopile at the gas valve terminals are tight and that the thermopile is fully inserted into the pilot bracket.</p> <p>Check the thermopile with a millivolt meter. Take the reading at TH-TP&amp;TP terminals of the gas valve. The meter should read 325 millivolts minimum, while holding the valve knob depressed in the pilot position, with the pilot lit, and the ON/OFF switch in the OFF position. Replace the faulty thermopile if the reading is below the specified minimum.</p> <p>With the pilot in the ON position, disconnect the thermopile leads from the valve. Take a reading at the thermopile leads. The reading should be 325 millivolts minimum. Replace the thermopile if the reading is below the minimum.</p>

Symptom	Possible Cause	Corrective Action
3. (Continued)	c. Defective valve.	Turn the valve knob to the ON position. Place the ON/OFF switch in the ON position. Check the millivolt meter at the thermopile terminals. The millivolt meter should read greater than 125mV. If the reading is acceptable, and if the burner does not come on, replace the gas valve.
	d. Plugged burner orifice.	Check the burner orifice for stoppage. Remove stoppage.
	e. Wall switch or wires are defective.	Follow the corrective action in Symptom and Possible Cause 1.a. Check the switch and wiring. Replace where defective.
4. Frequent pilot outage problem.	a. Pilot flame may be too high or too low, or blowing (high), causing safety pilot to drop out.	Clean and adjust the pilot flame for maximum flame impingement on thermocouple. Follow lighting instructions carefully.
5. The pilot and main burner extinguish while in operation.	a. No LP in tank.	Check the LP (propane) tank. Refill the fuel tank.
	b. Inner vent pipe leaking exhaust gases back into the system.	Check for proper vent connection at flue collar and all vent joints.
	c. Horizontal vent improperly pitched.	The horizontal vent cap should slope down only enough to prevent any water from entering the appliance.
	d. Bad thermopile or thermocouple.	Replace if necessary.
	e. Improper vent cap installation.	Check for proper installation and freedom from debris or blockage.
6. Glass soots.	a. Flame impingement.	Adjust the log set so that the flame does not excessively impinge on it. Check that logs are placed according to installation instructions.
	b. Improper shutter setting.	Adjust the air shutter at the base of the burner.
	c. Debris around opening at base of burner.	Inspect the opening at the base of the burner. NO MATERIAL SHOULD BE PLACED IN THIS OPENING.
7. Flame burns blue and lifts off burner.	a. Insufficient oxygen being supplied.	Ensure that the vent cap is installed properly and free of debris. Ensure that the vent system joints are tight and have no leaks.  Ensure that no debris has been placed at the base of, or in the area of the air holes in the center of the base pan beneath the burner.  Ensure that the glass is tightened properly on the appliance, particularly on top corners.



# 11 Maintaining and Servicing your Appliance

Although the frequency of your appliance servicing and maintenance will depend on use and the type of installation, a qualified service technician should perform an appliance check-up at the beginning of each heating season.

## WARNING

Risk of injury or property damage.

### Before servicing:

- Turn off gas.
- Turn off electricity to appliance.
- Ensure appliance is completely cooled.

### After servicing:

- Replace Safety Barrier if removed.
- Replace front and glass, if removed.
- Reseal and reinstall any venting removed for servicing.

## WARNING



Annual inspection by qualified technician recommended.

### Check:

- Condition of glass, glass assembly and glass seal.
- Obstructions of combustion and ventilation air.
- Obstructions of termination cap.
- Burner ignition and operation.
- Burner air shutter adjustment
- Gas connections and fittings.

### Clean:

- Glass
- Air passageways, grilles, control compartment
- Burner, burner ports. **USE CAUTION WHEN CLEANING/ HANDLING CERAMIC BURNER.**



### Risk of:

- Fire
- Delayed ignition or explosion
- Exposure to combustion fumes
- Odors

## WARNING



Inspect external vent cap regularly.

- Ensure no debris blocks cap.
- Combustible materials blocking cap may ignite.
- Restricted air flow affects burner operation.



## CAUTION



Handle glass assembly with care.

**NOTE:** Clean glass after initial 3-4 hours operation. **Longer operation without cleaning glass may cause a permanent white film on glass.**

### When cleaning glass door:

- Avoid striking, scratching or slamming glass.
- Do NOT use abrasive cleaners.
- Use a hard water deposit glass cleaner on white film.
- Do NOT clean glass when hot.
- Turn off appliance after 3-4 hours of operation and **ALLOW TO COOL.**
- Remove and clean glass assembly.
- Replace glass assembly and operate appliance for additional 12 hours.

Refer to maintenance instructions.

## WARNING

Installation and repair should be done by a qualified service person. The appliance should be inspected before use and at least annually by a professional service person. More frequent cleaning may be required due to excessive lint from carpeting, bedding material, etc. It is imperative that control compartments, burners, and circulating air passageways of the appliance be kept clean.

## CAUTION

**Young children should be carefully supervised when they are in the same room as the appliance.**

**Toddlers, young children, and others may be susceptible to accidental contact burns. A physical barrier is recommended if there are at-risk individuals in the house. To restrict access to a fireplace or stove, install an adjustable safety gate to keep toddlers, young children, and other at-risk individuals out of the room and away from hot surfaces.”**

## A. Maintenance Tasks

Inspect	Maintenance Tasks
Doors	1. Inspect for scratches, dents or other damage and repair as necessary.
	2. Verify no obstructions to air flow.
	3. Verify maintenance of proper clearance to combustible household objects.
Gasket Seal, Glass Assembly and Glass	1. Inspect gasket seal and its condition.
	2. Inspect glass for scratches and nicks that can lead to breakage when exposed to heat.
	3. Confirm there is no damage to glass or glass frame, Replace as necessary.
	4. Verify that latches engage properly and glass attachment components are intact and operating properly. Replace as necessary.
	5. Clean glass. Replace glass assembly if severely coated with silicate deposits that cannot be removed.
Valve Compartment and Firebox Top	1. Vacuum and wipe out dust, cobwebs, debris or pet hair. Use caution when cleaning these areas. Screw tips that have penetrated the sheet metal are sharp and should be avoided.
	2. Remove any foreign objects.
	3. Verify unobstructed air circulation.
Logs	1. Inspect for broken, damaged, or missing logs. Replace as necessary.
	2. Verify correct log placement and no flame impingement causing sooting. Correct as necessary.
Firebox	1. Inspect for paint condition, warpage, corrosion or perforation. Sand and repaint as necessary.
	2. Replace appliance if firebox has been perforated.
Burner Ignition and Operation	1. Verify burner is properly secured and aligned with pilot or igniter.
	2. Clean off burner top, inspect for plugged ports, corrosion or deterioration. Replace burner if necessary. <b>USE CAUTION WHEN CLEANING/HANDLING CERAMIC BURNER.</b>
	3. Replace ember material with new dime-size and shape pieces. Do not block ports or obstruct lighting paths.
	4. Check for smooth lighting and ignition carryover to all ports. Verify there is no ignition delay.
	5. Inspect for lifting and other flame problems.
	6. Inspect orifice for soot, dirt or corrosion.
	7. Verify manifold and inlet pressures. Adjust regulator as required.
	8. Inspect pilot flame strength. Clean or replace orifice as necessary.
	9. Inspect thermocouple/thermopile sensor rod for soot, corrosion and deterioration. Clean with emery cloth or replace as required.
	10. Verify millivolt output. Replace as necessary.
Venting	1. Inspect venting for blockage or obstruction such as bird nests, leaves, etc.
	2. Confirm that termination cap remains clear and unobstructed by plants, etc.
	3. Verify that termination cap clearance to subsequent construction (building additions, decks, fences or sheds) has been maintained.
	4. Inspect for corrosion or separation.
	5. Verify weather stripping, sealing and flashing remains intact.
Remote Controls	1. Verify operation of remote.
	2. Replace batteries in remote transmitters and battery-powered receivers.
Safety Barrier	1. Inspect for damage and replace as necessary
	2. Remove cobwebs, hair or other debris as needed.

# 12 Reference Materials

## A. Appliance Dimension Diagram

Dimensions are actual appliance dimensions. Use for reference only. For clearances refer to Section 3.

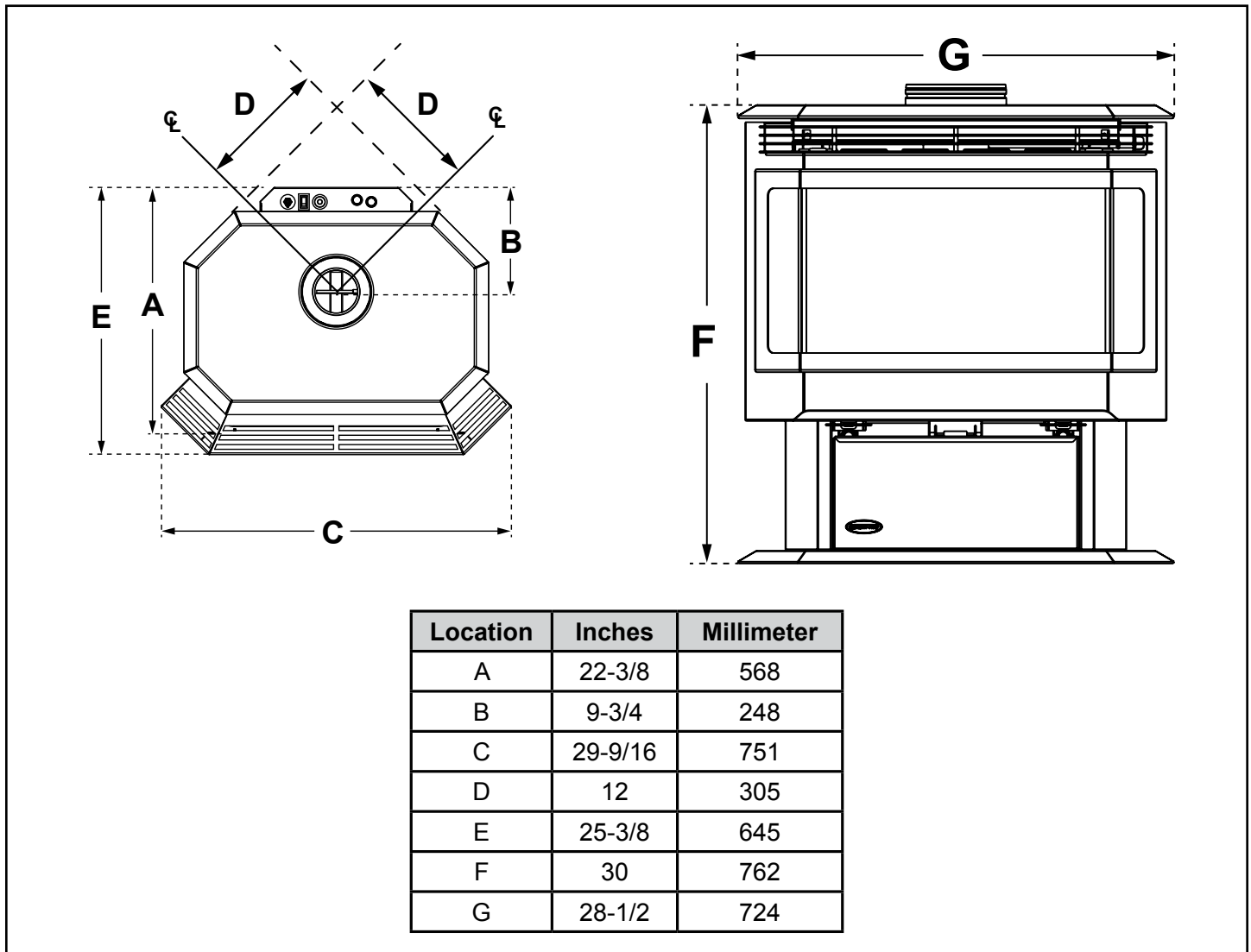

Figure 12.1 - Appliance Dimensions

## B. Vent Components Diagram

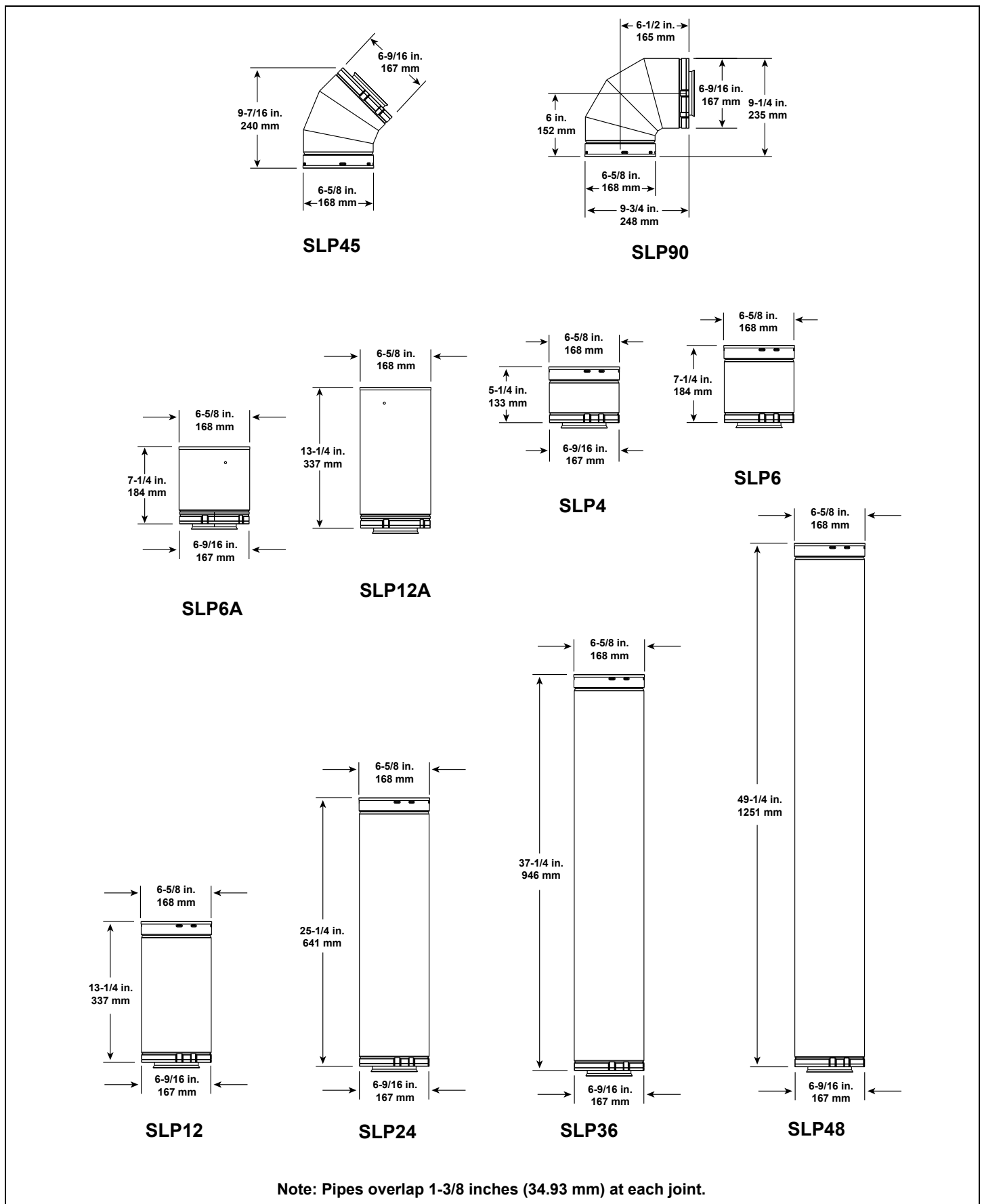
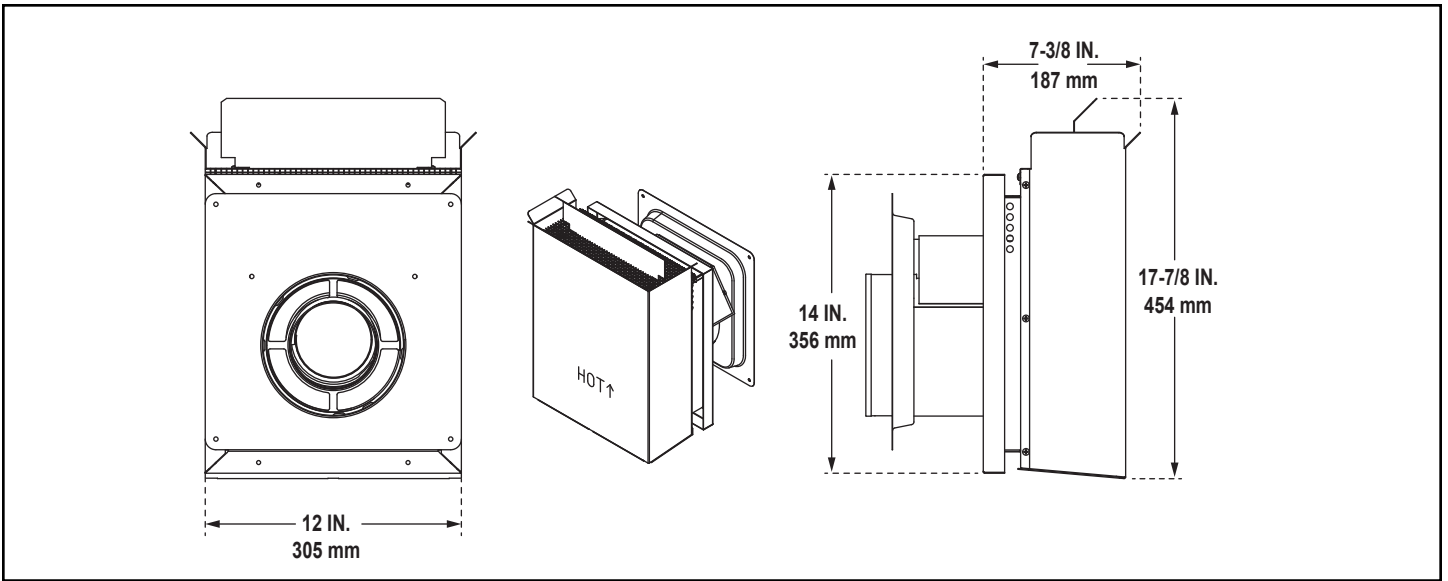

Figure 12.2 SLP Series Vent Components

**B. Vent Components Diagrams (continued)**



**Figure 12.3 SLP Series Vent Components**

## C. Vent Components List

COMPONENTS	
SLP-WT-BK	Ceiling Support / Wall Thimble, Black
SLP-CCS-BK	Cathedral Ceiling Support, Black
SLP6-BK	6 inch Pipe Length, Black
SLP4-BK	9 inch Pipe Length, Black
SLP12-BK	12 inch Pipe Length, Black
SLP34-BK	24 inch Pipe Length, Black
SLP36-BK	36 inch Pipe Length, Black
SLP48-BK	48 inch Pipe Length, Black
SLP6A-BK	11 inch - 14-5/8 inch Pipe Length, Black
SLP12A-BK	12 inch - 17 inch Pipe, Adjustable, Black
SLP45-BK	45 degree Elbow, Black
SLP90-BK	90 degree Elbow, Black
SLP4	4 inch Pipe
SLP6	6 inch Pipe
SLP12	12 inch Pipe
SLP24	24 inch Pipe
SLP36	36 inch Pipe
SLP48	48 inch Pipe
SLP45	45 degree Elbow
SLP90	90 degree Elbow
SLP6A	3-6 in. Adjustable Pipe Extension
SLP12A	3-12 in. Adjustable Pipe Extension
SLP-RF6	0/12 - 6/12 Roof Flashing
SLP-RF12	7/12 - 12/12 Roof Flashing
SL-SCD	Storm Collar
SLP-FS	Ceiling Firestop
SLP-WS	Wall Firestop
SLP-HVS	Pipe Support Hanger
950	Vinyl Protector Kit - SL Pipe
DRC-RADIUS	Decorative Radius Cover
RF4-8	Roof Flashing

TERMINATION KITS	
SLP-TRAP2	Trapezoid Termination Kit
SLP-TVHW	Vertical Termination Cap - High Wind
SLP-SK-BK	Horizontal Termination Kit (includes 904B, 930D, SLK-01TRD)
SLK-SNKD	Snorkel Kit
LINK-STOVE	Adapter Kit (includes 30 ft. of 4 inch flex, adapters, wall thimble, masonry & ZC flashing, 991DA cap and hardware package)
VPK-DV	Vinyl Siding Protector Kit
SLP-HHW2	HHW2 Horizontal High Wind Cap (recommended for optimal performance)
899-4491	HHW2K Horizontal Kit (one 90 degree black wall thimble, 24 inch black pipe, 11 inch - 14-5/8 inch adjustable vent, HHW2 termination cap)
844-8921	RHVK Snorkel Kit (with Dura-Vent parts 911B and 940)
MISCELLANEOUS	
46DVA-SC	Storm Collar
46DVA-FS	Ceiling Firestop
46DVA-WS	Wall Strap
46DVA-IS	Attic Insulation Shield
46DVA-GK	Chimney Liner Termination Kit
46DVA-GCL	Co-axial / Co-lineal Appliance Connector
46DVA-KMC	Retrofit Adj. Chimney Connector Retrofit Chimney Connector Plate

**Log Set Assembly**

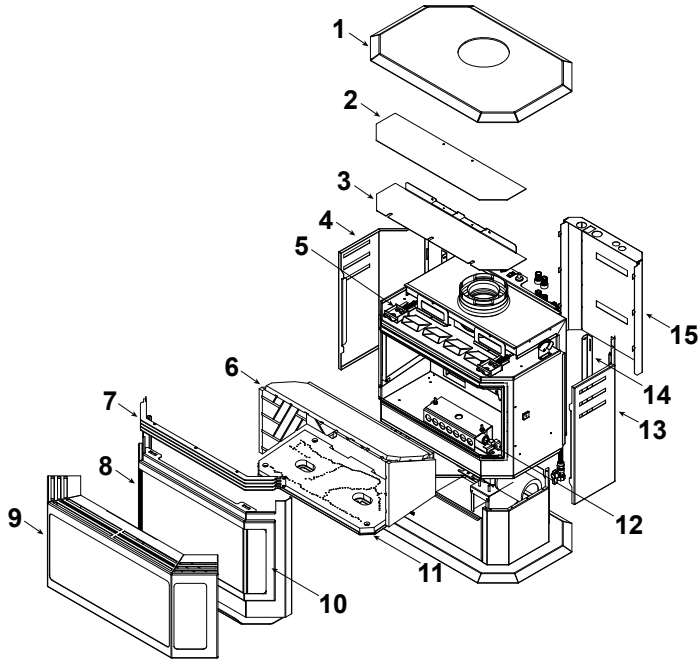

IMPORTANT: THIS IS DATED INFORMATION. Parts must be ordered from a dealer or distributor. **Hearth and Home Technologies does not sell directly to consumers.** Provide model number and serial number when requesting service parts from your dealer or distributor.



**Stocked at Depot**

ITEM	DESCRIPTION	COMMENTS	PART NUMBER	
	Log Set Assembly		7008-012	Y
1	Top Assembly	Pre SN 0021621084	SRV7003-010	
		Post SN 0021621084	7003-010	
2	Shield, Top		7003-154	
3	Shield, Lower		7003-153	
4	Outer Skin, Left	Pre SN 0021621084	SRV7003-117	
		Post SN 0021621084	7003-131	
5	Latch Assembly (Stationary)	Qty 2 req	7003-006	Y
6	Refractory Assembly		7008-002	
7	Grill Bar Assembly BLACK	Pre SN 0021621084	SRV7008-010	
		Post SN 0021621084	7008-010	
	Grill Bar Assembly	Gold	LVGRL-GD	
		Nickel	LVGRL-NL	
8	Door Assembly	Pre SN 0021621084	DOOR-HUDBAY	
		Post SN 0021621084	DOOR-HUDBAY-B	
	Gasket, Tadpole,	10 FT	842-5130	Y
	Glass Tape		832-0460	Y
9	Front, Mesh		7002-020	
10	Door Crown , BLACK	Pre SN 0021621084	SRV462-0150	
		Post SN 0021621084	462-0150	
	Door Crown	Gold	DC-BAY-GD	
		Nickel	DC-BAY-NL	

Additional service part numbers appear on following page.

Beginning Manufacturing Date: April 2003  
Ending Manufacturing Date: Active

IMPORTANT: THIS IS DATED INFORMATION. Parts must be ordered from a dealer or distributor. **Hearth and Home Technologies does not sell directly to consumers.** Provide model number and serial number when requesting service parts from your dealer or distributor.

**Stocked at Depot**

ITEM	DESCRIPTION	COMMENTS	PART NUMBER
11	Burner Assembly		SRV7008-004
12	Burner Neck Support Assembly		7008-005
13	Outer Skin, Right		7003-117
14	Side Curtain Mount		479-0110
15	Valve Cover	Pre SN 0021621084	SRV7003-119
		Post SN 0021621084	7003-119

### #16 Pedestal Components

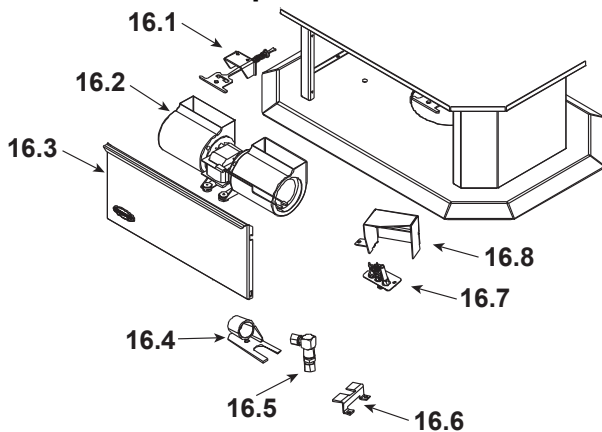

### #17 Valve Components

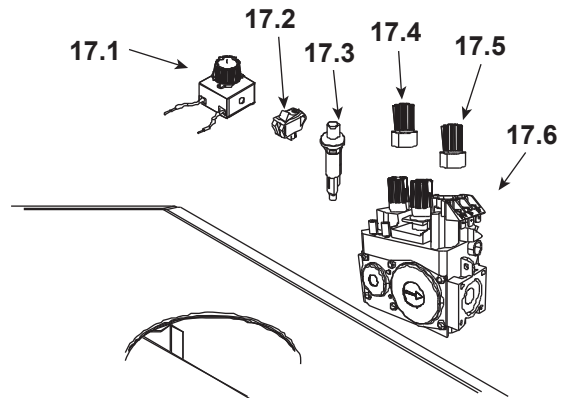

16.1	Latch Assembly (Qty 2 req)		7003-005	Y
16.2	Blower		812-4900	Y
	Blower Plate		457-0560	
	Blower Bracket		474-0210	
16.3	Pedestal Door	Pre SN 0021621084	SRV7003-107	
		Post SN 0021621084	7003-107	
16.4	Air Shutter Assembly		468-5060	Y
16.5	Bulkhead		26457	Y
16.6	Bulkhead Stop		474-0090	
16.7	Pilot Assembly		842-4940	Y
16.8	Pilot Shield		PS-7008	
17.1	Speed Control		842-0370	Y
			200-2041	Y
17.2	On/Off Rocker Switch		230-0730	Y
17.3	Piezo Ignitor		291-513	Y
17.4	Knob On/Off		571-534	Y
17.5	Knob Hi/Lo		571-533	Y
17.6	Valve NG		842-0240	Y
	Valve LP		842-0230	Y
	Valve Bracket		7003-118	

Additional service part numbers appear on following page.



IMPORTANT: THIS IS DATED INFORMATION. Parts must be ordered from a dealer or distributor. **Hearth and Home Technologies does not sell directly to consumers.** Provide model number and serial number when requesting service parts from your dealer or distributor.



**Stocked  
at Depot**

ITEM	DESCRIPTION	COMMENTS	PART NUMBER	
	Adaptor	Inner 4"	200-2470	
	Adaptor	6 5/8"	7010-172	
	Brick Retainer		479-0190	
	Electrode	EZ Flush 42	842-4580	Y
	Fan Deflector		468-0190	
	Flex Line	3/8 comp x 30 "	200-2940A	Y
	Flex Line		3-40-2098034	Y
	Mineral Wool		050-721	
	Orifice LP (.076) Port		29388	Y
	Orifice NG (.125)		24691	Y
	Power Cord		832-2410	Y
	Snap Disc		SRV230-0960	Y
	Wire Harness		474-0350	Y
	Component Pack		7003-007	
	Contains: Mineral Wool; On/off Flex Assembly, Pilot Injector, EZ,35;, Regulator LP, Orifice 0.76 port, Burner neck			
	Thermocouple		200-2950	Y
	Thermopile		842-0250	Y
	Touch Up Paint	Pre 0021621084	812-0910	
		Pre 0021200001	TUP-GBK-12	
		Post 0081200001	3-42-19905	
	Conversion Kit NG		N/A	Y
	Conversion Kit LP		LPK-7008	Y
	Pilot Orifice NG		842-4440	Y
	Pilot Orifice LP		200-2630	Y
	Regulator NG		230-1570	Y
	Regulator LP		230-1520	Y

## E. Limited Lifetime Warranty

### Hearth & Home Technologies LIMITED LIFETIME WARRANTY

Hearth & Home Technologies, on behalf of its hearth brands (“HHT”), extends the following warranty for HHT gas, wood, pellet, coal and electric hearth appliances that are purchased from an HHT authorized dealer.

#### **WARRANTY COVERAGE:**

HHT warrants to the original owner of the HHT appliance at the site of installation, and to any transferee taking ownership of the appliance at the site of installation within two years following the date of original purchase, that the HHT appliance will be free from defects in materials and workmanship at the time of manufacture. After installation, if covered components manufactured by HHT are found to be defective in materials or workmanship during the applicable warranty period, HHT will, at its option, repair or replace the covered components. HHT, at its own discretion, may fully discharge all of its obligations under such warranties by replacing the product itself or refunding the verified purchase price of the product itself. The maximum amount recoverable under this warranty is limited to the purchase price of the product. This warranty is subject to conditions, exclusions and limitations as described below.

#### **WARRANTY PERIOD:**

Warranty coverage begins on the date of original purchase. In the case of new home construction, warranty coverage begins on the date of first occupancy of the dwelling or six months after the sale of the product by an independent, authorized HHT dealer/ distributor, whichever occurs earlier. The warranty shall commence no later than 24 months following the date of product shipment from HHT, regardless of the installation or occupancy date. The warranty period for parts and labor for covered components is produced in the following table.

The term “Limited Lifetime” in the table below is defined as: 20 years from the beginning date of warranty coverage for gas appliances, and 10 years from the beginning date of warranty coverage for wood, pellet, and coal appliances. These time periods reflect the minimum expected useful lives of the designated components under normal operating conditions.

Warranty Period		HHT Manufactured Appliances and Venting							Components Covered
Parts	Labor	Gas	Wood	Pellet	EPA Wood	Coal	Electric	Venting	
1 Year		X	X	X	X	X	X	X	All parts and material except as covered by Conditions, Exclusions, and Limitations listed
2 years				X	X	X			Igniters, electronic components, and glass
		X	X	X	X	X			Factory-installed blowers
		X		X					Molded refractory panels
3 years				X					Ignition Modules
5 years	1 year			X	X				Firepots and burnpots
7 years	3 years		X	X	X				Castings and baffles
10 years	1 year	X							Manifold tubes, HHT chimney and termination
Limited Lifetime	3 years	X	X	X	X	X			Burners, logs and refractory
90 Days		X	X	X	X	X	X	X	Firebox and heat exchanger
									All replacement parts beyond warranty period

See conditions, exclusions, and limitations on next page.

## **E. Limited Lifetime Warranty (*continued*)**

### **WARRANTY CONDITIONS:**

- This warranty only covers HHT appliances that are purchased through an HHT authorized dealer or distributor. A list of HHT authorized dealers is available on the HHT branded websites.
- This warranty is only valid while the HHT appliance remains at the site of original installation.
- This warranty is only valid in the country in which the HHT authorized dealer or distributor that sold the appliance resides.
- Contact your installing dealer for warranty service. If the installing dealer is unable to provide necessary parts, contact the nearest HHT authorized dealer or supplier. Additional service fees may apply if you are seeking warranty service from a dealer other than the dealer from whom you originally purchased the product.
- Check with your dealer in advance for any costs to you when arranging a warranty call. Travel and shipping charges for parts are not covered by this warranty.

### **WARRANTY EXCLUSIONS:**

This warranty does not cover the following:

- Changes in surface finishes as a result of normal use. As a heating appliance, some changes in color of interior and exterior surface finishes may occur. This is not a flaw and is not covered under warranty.
- Damage to printed, plated, or enameled surfaces caused by fingerprints, accidents, misuse, scratches, melted items, or other external sources and residues left on the plated surfaces from the use of abrasive cleaners or polishes.
- Repair or replacement of parts that are subject to normal wear and tear during the warranty period. These parts include: paint, wood, pellet and coal gaskets, firebricks, grates, flame guides, batteries and the discoloration of glass.
- Minor expansion, contraction, or movement of certain parts causing noise. These conditions are normal and complaints related to this noise are not covered by this warranty.
- Damages resulting from: (1) failure to install, operate, or maintain the appliance in accordance with the installation instructions, operating instructions, and listing agent identification label furnished with the appliance; (2) failure to install the appliance in accordance with local building codes; (3) shipping or improper handling; (4) improper operation, abuse, misuse, continued operation with damaged, corroded or failed components, accident, or improperly/incorrectly performed repairs; (5) environmental conditions, inadequate ventilation, negative pressure, or drafting caused by tightly sealed constructions, insufficient make-up air supply, or handling devices such as exhaust fans or forced air furnaces or other such causes; (6) use of fuels other than those specified in the operating instructions; (7) installation or use of components not supplied with the appliance or any other components not expressly authorized and approved by HHT; (8) modification of the appliance not expressly authorized and approved by HHT in writing; and/or (9) interruptions or fluctuations of electrical power supply to the appliance.
- Non-HHT venting components, hearth components or other accessories used in conjunction with the appliance.
- Any part of a pre-existing fireplace system in which an insert or a decorative gas appliance is installed.
- HHT's obligation under this warranty does not extend to the appliance's capability to heat the desired space. Information is provided to assist the consumer and the dealer in selecting the proper appliance for the application. Consideration must be given to appliance location and configuration, environmental conditions, insulation and air tightness of the structure.

### **This warranty is void if:**

- The appliance has been over-fired or operated in atmospheres contaminated by chlorine, fluorine, or other damaging chemicals. Over-firing can be identified by, but not limited to, warped plates or tubes, rust colored cast iron, bubbling, cracking and discoloration of steel or enamel finishes.
- The appliance is subjected to prolonged periods of dampness or condensation.
- There is any damage to the appliance or other components due to water or weather damage which is the result of, but not limited to, improper chimney or venting installation.

### **LIMITATIONS OF LIABILITY:**



- The owner's exclusive remedy and HHT's sole obligation under this warranty, under any other warranty, express or implied, or in contract, tort or otherwise, shall be limited to replacement, repair, or refund, as specified above. In no event will HHT be liable for any incidental or consequential damages caused by defects in the appliance. Some states do not allow exclusions or limitation of incidental or consequential damages, so these limitations may not apply to you. This warranty gives you specific rights; you may also have other rights, which vary from state to state. EXCEPT TO THE EXTENT PROVIDED BY LAW, HHT MAKES NO EXPRESS WARRANTIES OTHER THAN THE WARRANTY SPECIFIED HEREIN. THE DURATION OF ANY IMPLIED WARRANTY IS LIMITED TO DURATION OF THE EXPRESSED WARRANTY SPECIFIED ABOVE.

# QUADRA-FIRE®

## CONTACT INFORMATION:

Quadra-Fire, a brand of Hearth & Home Technologies  
352 Mountain House Road, Halifax, Pa 17032  
www.quadrafire.com

Please contact your Quadra-Fire dealer with any questions or concerns.  
For the number of your nearest Quadra-Fire dealer,  
please visit our web site [www.quadrafire.com](http://www.quadrafire.com)

 <b>CAUTION</b>	
	Do NOT discard this manual.
	<ul style="list-style-type: none"><li>• Important operating and maintenance instructions included.</li><li>• Read, understand and follow these instructions for safe installation and operation.</li><li>• Leave this manual with party responsible for use and operation.</li></ul>



### Your Records for Model: Hudson Bay Direct Vent Gas Appliance

DEALERSHIP WHERE PURCHASED:

SERIAL NUMBER: \_\_\_\_\_

DATE PURCHASED: \_\_\_\_\_

DATE INSTALLED: \_\_\_\_\_

DEALER TELEPHONE: \_\_\_\_\_

This product may be covered by one or more of the following patents: (United States) 5613487, 5647340, 5890485, 5941237, 6006743, 6019099, 6053165, 6145502, 6374822, 6484712, 6601579, 6769426, 6863064, 7077122, 7098269, 7258116, 7470729, 8147240 or other U.S. and foreign patents pending.

*Printed in U.S.A. - Copyright 2014*