

## Installation & Operating Manual

# The Harman 44 Magnum Coal Stove

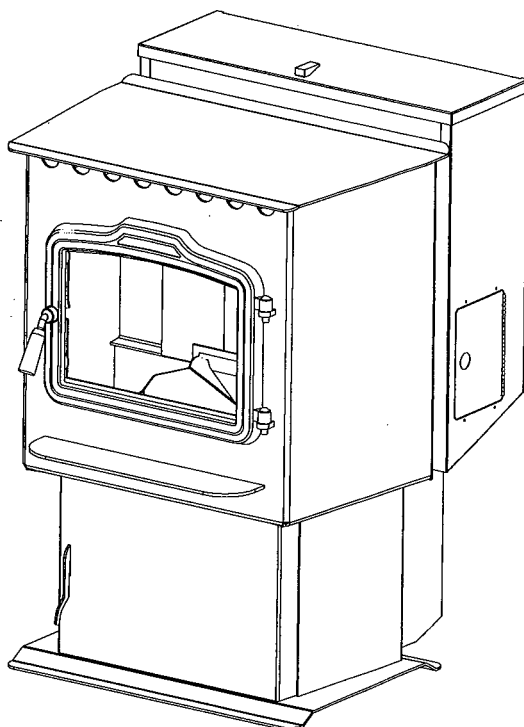

We suggest that our hearth products be installed and serviced by professionals who are certified in the U.S. by the National Fireplace Institute (NFI) as NFI Specialists.

R4

## SAFETY NOTICE

**PLEASE READ THIS ENTIRE MANUAL BEFORE YOU INSTALL AND USE YOUR NEW ROOM HEATER. FAILURE TO FOLLOW INSTRUCTIONS MAY RESULT IN PROPERTY DAMAGE, BODILY INJURY, OR EVEN DEATH.**

**FOR USE IN THE U.S. AND CANADA. SUITABLE FOR INSTALLATION IN MOBILE HOMES**

**IF THIS HARMAN STOVE IS NOT PROPERLY INSTALLED, A HOUSE FIRE MAY RESULT. FOR YOUR SAFETY, FOLLOW INSTALLATION DIRECTIONS.**

**CONTACT LOCAL BUILDING OR FIRE OFFICIALS ABOUT RESTRICTIONS AND INSTALLATION INSPECTION REQUIREMENTS IN YOUR AREA.**

**CONTACT YOUR LOCAL AUTHORITY (SUCH AS MUNICIPAL BUILDING DEPARTMENT, FIRE DEPARTMENT, FIRE PREVENTION BUREAU, ETC.) TO DETERMINE THE NEED FOR A PERMIT.**

**CETTE GUIDE D'UTILISATION EST DISPONIBLE EN FRANCAIS. CHEZ VOTRE CONCESSIONNAIRE DE HARMAN STOVE COMPANY.**

**SAVE THESE INSTRUCTIONS.**



### LISTED COAL BURNING ROOM HEATER MODEL: "44MAG"

INSTALL WITH MINIMUM  
CLEARANCES TO WALLS AS  
SHOWN

TESTED TO :  
UL 1482  
ASTM E1509-95  
ULC-S627  
TEST DATE: JUNE 9, 1998

GL-

DO NOT REMOVE THIS  
LABEL

**MINIMUM CLEARANCES TO COMBUSTIBLES:**

	WITHOUT SIDE SHIELDS	WITH SIDE SHIELDS
SIDEWALL TO STOVE	16"	8"
BACKWALL TO STOVE	11"	11"
CEILING TO STOVE TOP	20"	20"
STOVE CORNER TO DIAGONAL WALL	10.5"	10.5"
CHIMNEY CONNECTOR TO WALL	5"	5"

PREVENT HOUSE FIRES, OPERATE WITH VIEWING & ASH DOOR CLOSED.  
UNIT MUST BE PLACE ON A NON-COMBUSTIBLE FLOOR PROTECTOR EX-  
TENDING 6" TO THE FRONT, 6" TO SIDES AND 1" TO REAR.

**EXHAUST TYPE:** CLASS "A" CHIMNEY AND CLASS "A" CHIMNEY CONNec-  
TOR. CHIMNEY MUST PROVIDE DRAFT OF AT LEAST .03" W.C.

**ELECTRICAL RATING:** 3 AMPS, 120 VOLTS, 60 HERTZ

**FUEL:** ANTHRACITE RICE COAL. ALSO BITUMINOUS OF SAME SIZE.

INSTALL AND USE ONLY IN ACCORDANCE WITH MANUFACTURER'S INSTAL-  
LATION AND OPERATING INSTRUCTIONS. CONTACT LOCAL BUILDING OR  
FIRE OFFICIALS ABOUT RESTRICTIONS & INSTALLATION INSPECTION IN  
YOUR AREA.

**U.S. ENVIRONMENTAL PROTECTION AGENCY** THIS UNIT IS ONLY FOR  
BURNING COAL. USE OF ANY OTHER SOLID FUEL EXCEPT FOR COAL IGNI-  
TION PURPOSES IS A VIOLATION OF FEDERAL LAW.

INPUT RATING: .55 TO 3.75 LBS PER HOUR.

**DO NOT CONNECT THIS UNIT TO A CHIMNEY SERV-  
ING ANOTHER APPLIANCE**

CORNER INSTALLATION  
WITH OR WITHOUT  
SIDE SHIELDS

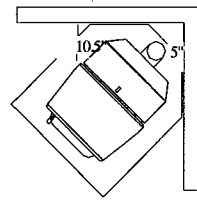

SIDEWALL-BACKWALL  
INSTALLATION  
WITH SIDE SHIELDS

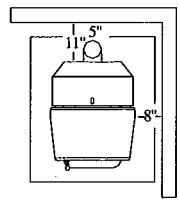

SIDEWALL-BACKWALL  
INSTALLATION  
WITHOUT SIDE SHIELDS

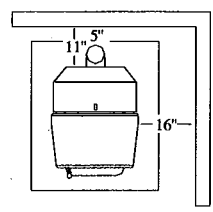

FLOOR  
PROTECTOR  
MINIMUM SIZE

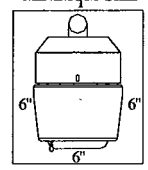

MANUFACTURED BY:

HARMAN STOVE COMPANY  
352 MTN. HOUSE ROAD  
HALIFAX, PA. 17032



# Contents

<b>Assembly &amp; Installation</b>	<b>5</b>
<b>Chimney</b>	<b>11</b>
<b>Operation</b>	<b>14</b>
<b>Turbo Control</b>	<b>15</b>
<b>Maintenance</b>	<b>17</b>
<b>Trouble Shooting</b>	<b>19</b>
<b>Feeder Parts</b>	<b>20</b>
<b>Specifications</b>	<b>20</b>
<b>Wiring Diagram</b>	<b>21</b>
<b>Options</b>	<b>22</b>
<b>Part Numbers</b>	<b>24</b>
<b>Warranty</b>	<b>25</b>

000000 0000 0000 000000 000000 000000 000 00000000 000 000 0000 000  
 0000 000000. 0000000 00 000000 00000000000000 000 0000000 00  
 000000000 000000, 0000000 0000000, 00 0000 000000.

0000 00000 0000000000000

0000000 000000 000000000

352 000000000 000000 00000

00000000, 00 17032

## Carbon Monoxide (CO) Awareness

Carbon monoxide referred to as CO, is a colorless, odorless gas that is produced during combustion of coal and other fuels. **CO fumes are toxic and can be fatal.**

Even though this stove is designed to be as safe as possible, it is important that you **install a CO detector**. This is true for oil, gas, or wood as well.

CO is heavier than air. This causes accumulation to occur at the floor first. Therefore, it is best to install the detector at table top level or lower rather than on the ceiling like a smoke detector.

CO detectors are very sensitive and may sound

an alarm for fumes other than CO or CO from sources other than the stove such as car or lawn mower exhaust.

If the alarm sounds

1. Increase ventilation by opening windows or doors.
2. Make sure the stove doors and hopper lid are closed and latched.
3. Check stove for electrical power and normal operation.
4. Check for false alarm.

**(Never sleep in the same room with any coal burning stove.)**

### Wet Coal

Freshly delivered coal is watered down to eliminate dust when loading and unloading. Wet coal does not flow as well as dry coal. **We do not recommend burning wet coal**; however, we realize if it's the only coal you have, it is better to burn it than be cold. If you must burn wet coal, the feed rate must be increased in order to get the same size fire. As the wet coal in the hopper dries out, the feed rate may need to be adjusted. Doing this once or twice a year will not damage your stove as long as it is hot and burning. If you must burn wet coal use a feed rate setting of "3" or higher. The damage is caused when the hopper has wet coal in it when the stove is cold. **This will cause rust and corrosion and it is totally the operator's fault.** Usually after the coal dries for three or four days, depending on conditions, it will flow very well and feed properly. Feed rate will be the same as dry coal.

### Always Empty Hopper

**Always empty hopper when not burning for more than a week. When left standing for long periods with wet coal, the slide plate will rust and corrode, causing it to seize. If the stoker is then turned "on", damage to the pusher assembly and feed motor could result. This will be considered neglect and will void the warranty on those parts. Always check to see if moving parts are free before using if the unit has not been burned for a period of time. This can best be determined by watching the end of the auger in the bottom of the burnpot.**

**Never use gasoline, gasoline-type lantern fuel, kerosene, charcoal lighter fluid, or similar liquids to start or "freshen up" a fire in this heater. Keep all such liquids well away from the heater while it is in use.**

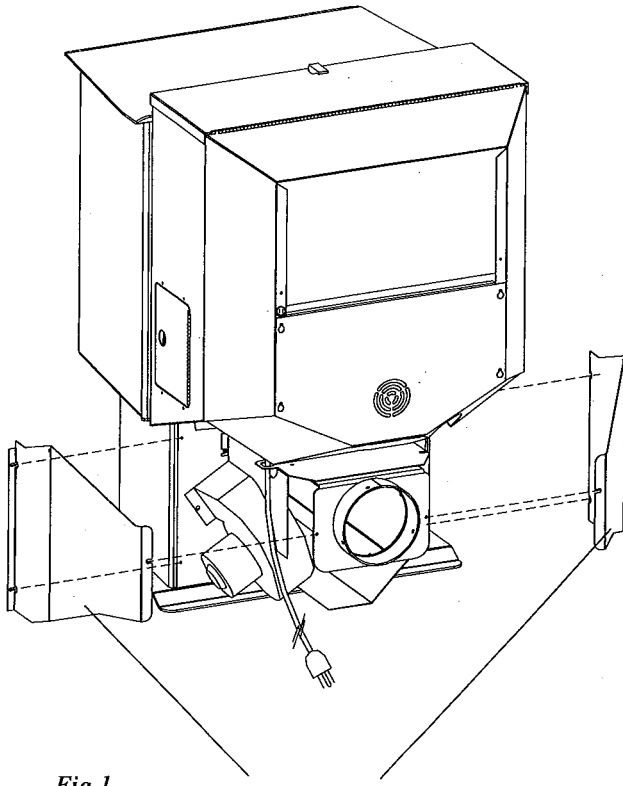

Fig.1

Rear Cover Panels

## Unpacking

Cut straps holding box together and remove box from skid.

The 44 Magnum is bolted to the skid to prevent movement during shipping.

To free the stove from the skid you must remove the hold-down bolts in the rear of the pedestal base.

## Installing rear cover panels

The rear cover panels are removed from the stove to make it easier to get at the hold-down bolts.

The rear cover panels are packed inside the hopper and should be installed on the stove as shown. This can be done before or after the stove is in place.

## Firebrick

Install the firebrick vertically on the angle above the burnpot. See Figure 2.

## Flame Guide

Install the cast iron flame guide on top of the burnpot and make sure it is fully seated against the auger opening. See Figure 2. The bottom of the flame guide is marked 44ND.

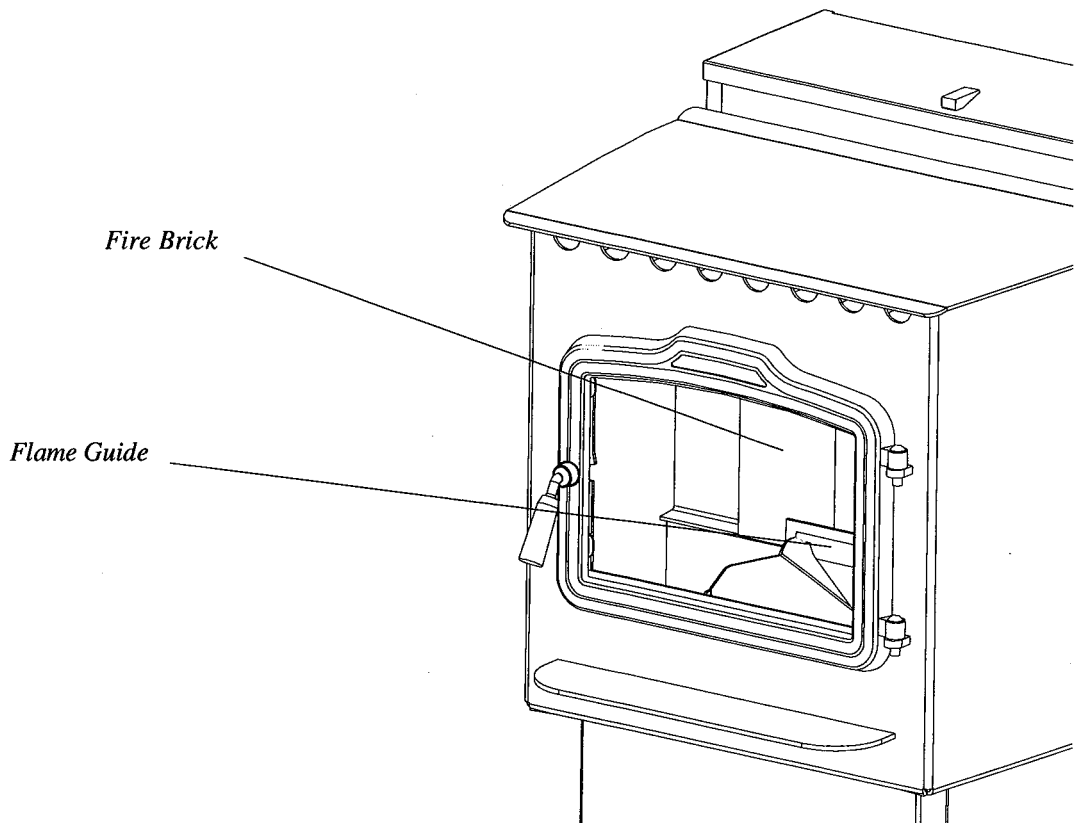

Fig.2

Fig.3

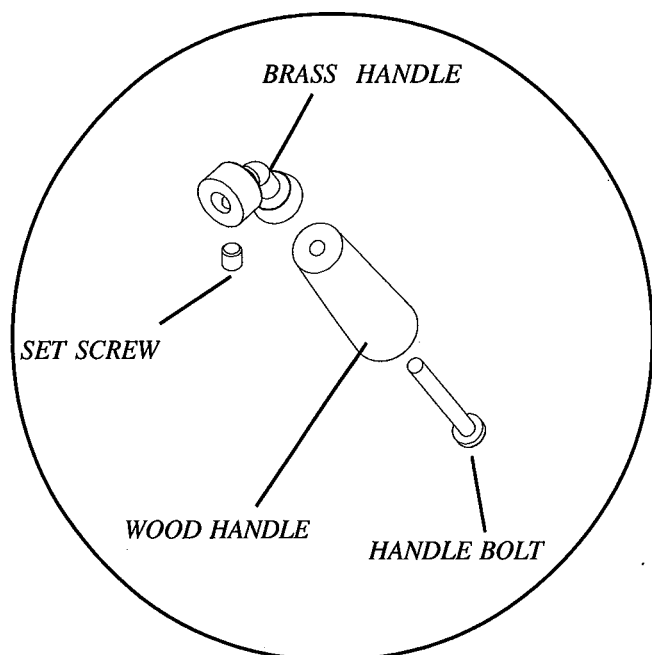
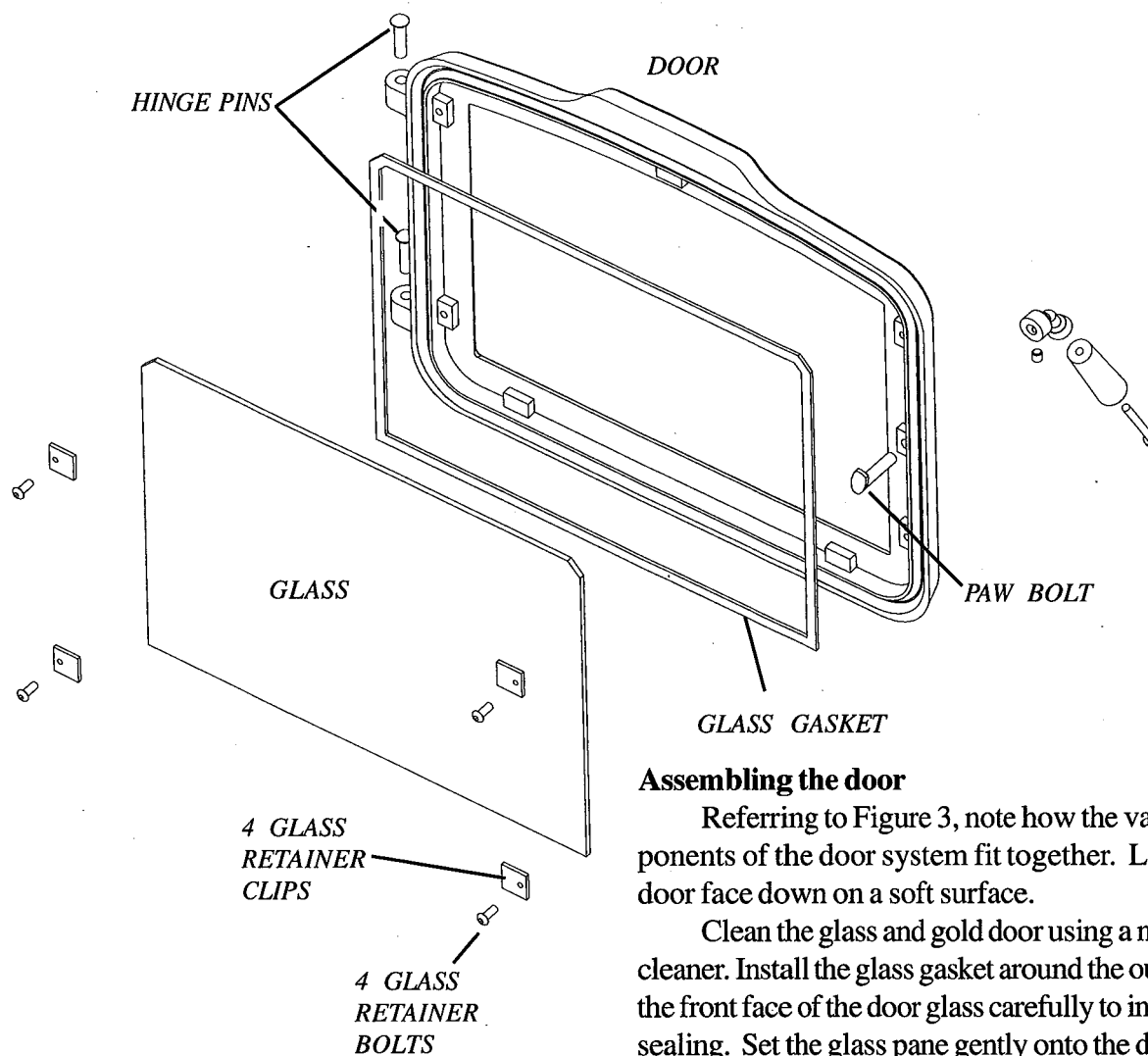

Fig. 4

### Assembling the door

Referring to Figure 3, note how the various components of the door system fit together. Lay the load door face down on a soft surface.

Clean the glass and gold door using a nonabrasive cleaner. Install the glass gasket around the outer edge of the front face of the door glass carefully to insure proper sealing. Set the glass pane gently onto the door. Install the hold-down clips and tighten with bolts as shown.

Install door on stove with hinge pins.

Install door handle as shown on the diagram.

**NOTE:** With the flat surface of the paw bolt to the inside of the door.

Turn the paw bolt "in" for approximately 17 turns.

Turn the brass elbow onto the paw bolt approximately 5 turns.

Align the set screw with the flat spot on the paw and tighten.

After attaching the door handle, close and latch the door by turning the handle to the six o'clock position. Does the door rope compress? If not, loosen the set screw, and turn the paw bolt one more turn into the door. Repeat as required to achieve a tight door fit.

**NOTE:** Remember to thoroughly clean the glass and the gold door frame before lighting the stove for the first time.

## Installing

Place the stove on a noncombustible floor or UL approved floor protector that extends 6 inches to the front, 6 inches to the sides and 1 inch to the rear of the stove pipe.

Place the stove away from combustible walls at least as far as shown in Figures 6, 7 and 8. Please note the difference in side wall clearance with and without side shields.

Note that the clearances shown are minimum for safety but do not leave much room for access when cleaning or servicing. Please take this into account when placing the stove.

Connect the power cord to a 120 V.A.C. 60Hz grounded receptacle.

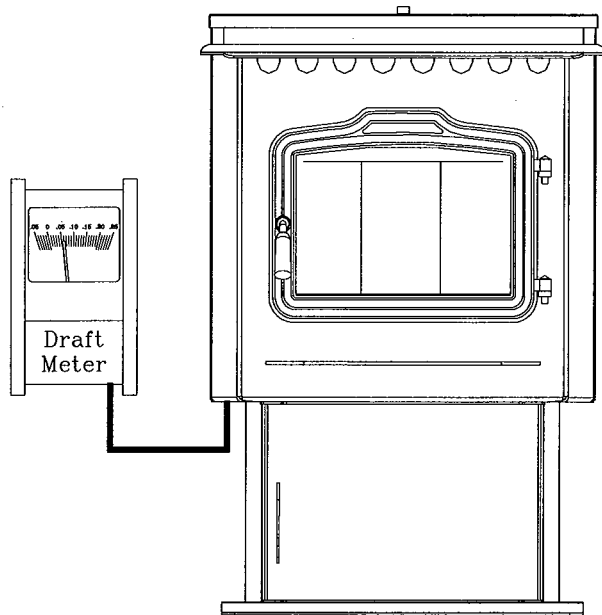

Fig.5

## Checking Draft

Connect a draft meter to the draft port located on the lower left rear of the firebox. With a fire burning in the stove, check the draft with the temperature dial set at "1" and at "Turbo". The draft reading should never be less than .03. If the draft is below .03 the chimney must be improved or a draft inducer must be installed.

### WARNING!

**If draft is at .00, carbon monoxide may escape into the room. Too much carbon monoxide can kill you.**

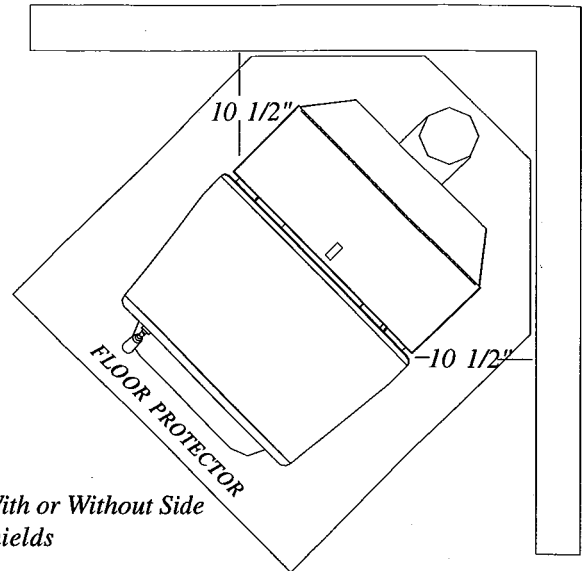

With or Without Side Shields

Fig. 6

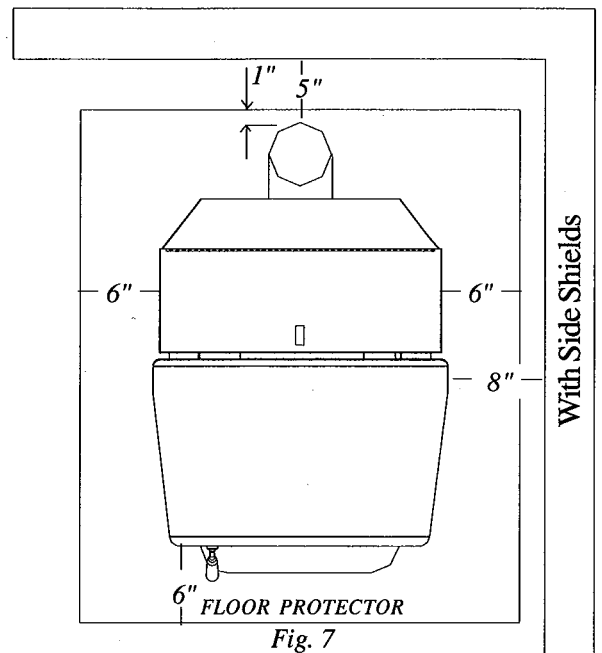

Fig. 7

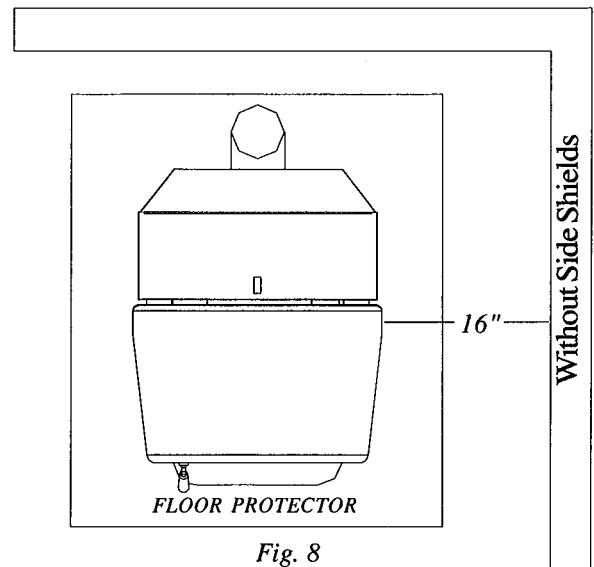

Fig. 8

**DO NOT INSTALL A FLUE DAMPER IN THE EXHAUST VENTING SYSTEM OF THIS UNIT.**

**DO NOT CONNECT THIS UNIT TO A CHIMNEY FLUE SERVING ANOTHER APPLIANCE.**

**INSTALL VENT AT CLEARANCES SPECIFIED BY THE VENT MANUFACTURER**

**WARNING**  
**DO NOT INSTALL IN SLEEPING ROOM**

**CAUTION**  
**The stove is hot while in operation. Keep children, clothing and furniture away. Contact may cause skin burns.**

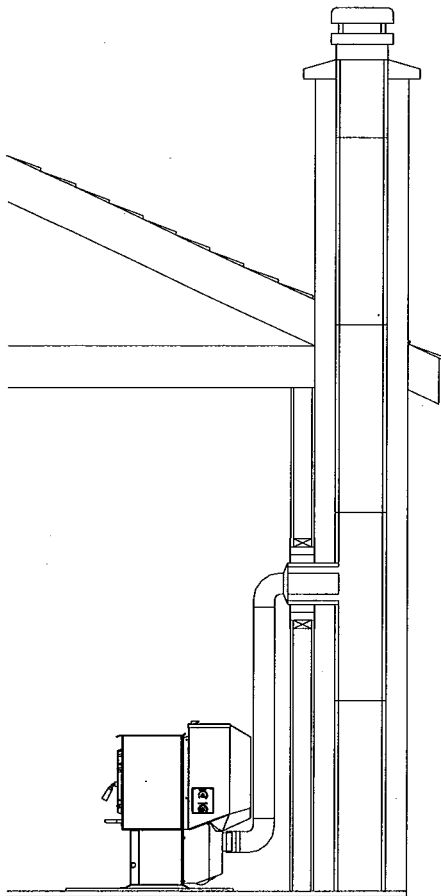

*Fig. 9*

### **Installing Into An Existing Chimney**

The chimney connector should extend into the chimney flush with the inside as shown above.

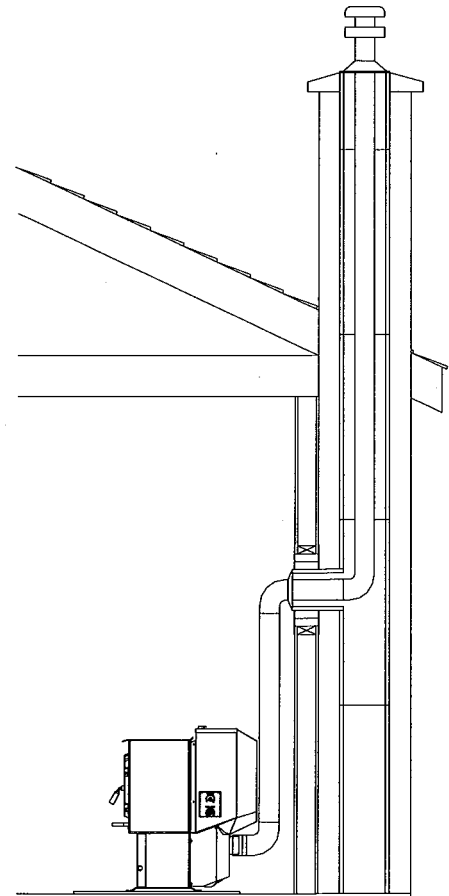

*Fig. 10*

### **Installing Into An Existing Chimney and Adding a Liner.**

If the chimney condition is questionable or does not provide enough draft you may want to install a liner.



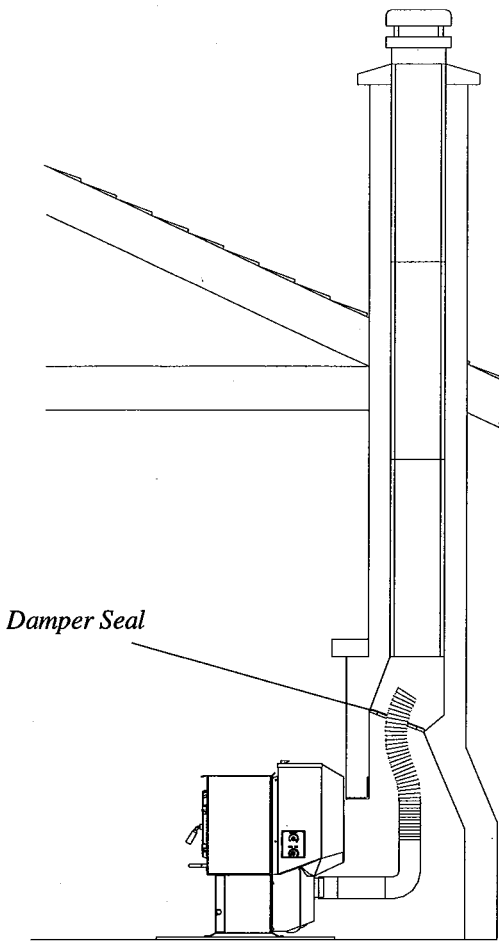

Fig. 11

## Installing into an existing chimney

In this method a cap should also be installed to keep rain from entering the chimney. The chimney connector must extend up through the damper area and be sealed to prevent draft leakage.

One disadvantage of this method is that it is harder to clean the vent pipe; therefore, there is a tendency not to clean it as often as needed.

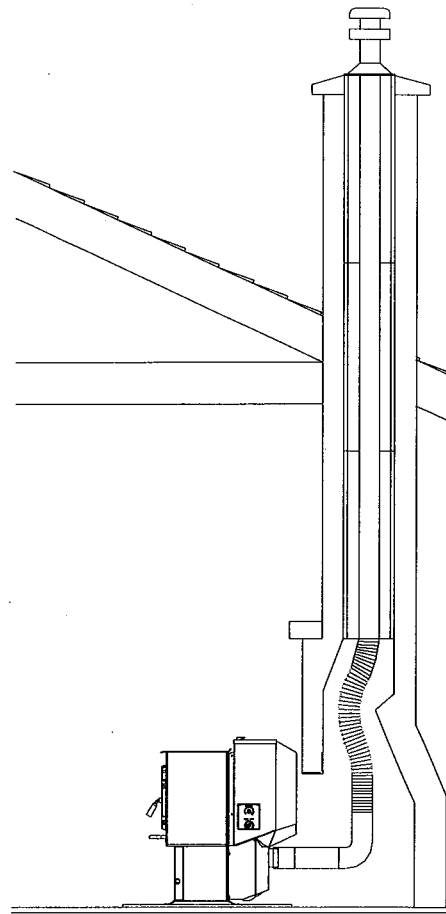

Fig 12

## Installing into an existing fireplace chimney

In Canada and some places in the US it is required that the vent pipe extend all the way to the top of the chimney. In Canada and some places in the US it is required that the vent pipe extend all the way to the top of the chimney. The pipe or liner inside the chimney should be 5" diameter.

In this method a cap should also be installed to keep the rain from entering the chimney.

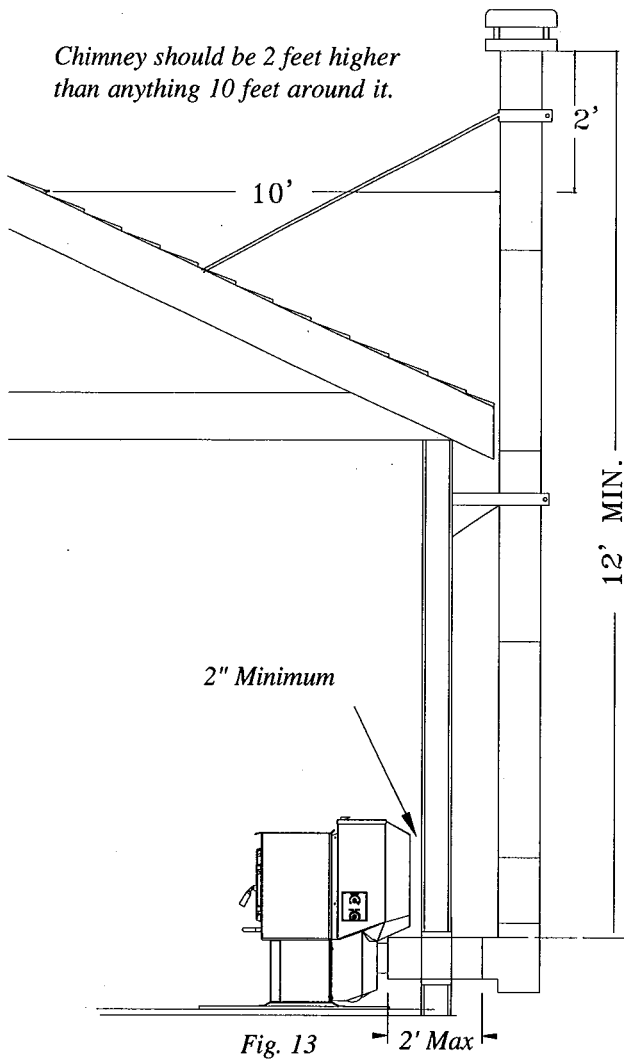

Fig. 13

**Installation with External Prefabricated Chimney**

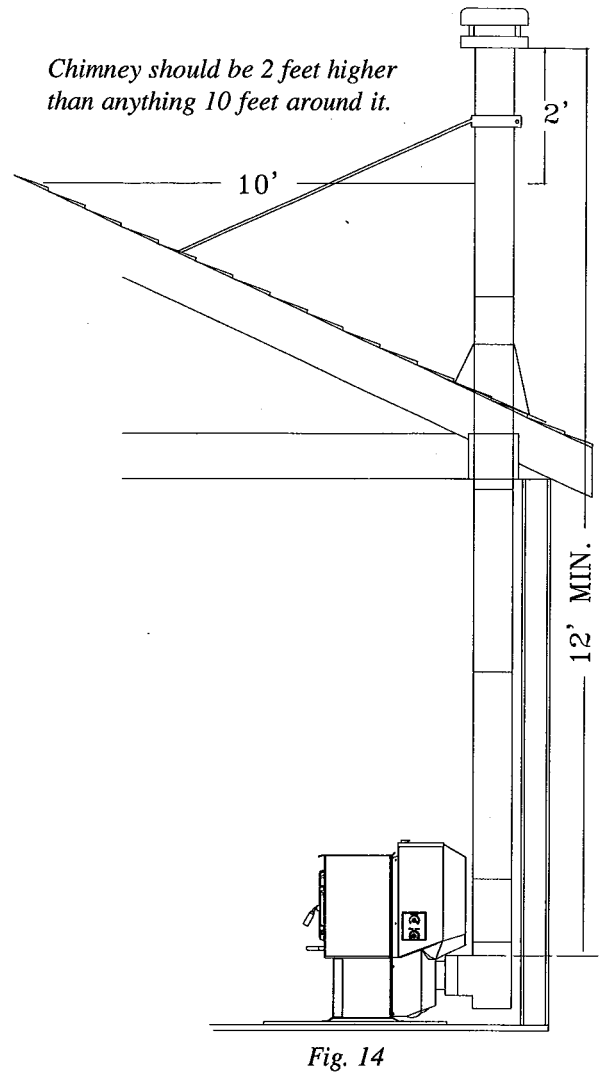

Fig. 14

**Installation with Internal Prefabricated Chimney**

**Installing to a Prefabricated Chimney**

When venting your 44 Magnum using a prefabricated chimney, be sure to contact your local building code authorities, and to follow the manufacturer's instructions exactly. Use a 5 or 6 inch manufactured type HT chimney with a rating of 1000 degrees fahrenheit or more.

Use only the manufacturer's parts; do not use makeshift installation techniques. All prefabricated chimneys must be tested to either the U.S. or Canadian high temperature standards, UL 103 or ULC-629.

Minimum clearances are set by the chimney manufacturer. Be sure to use the minimum clearance to combustables that are set by the chimney manufacturer.

# Chimney Connectors and Chimneys

## Draft

Connectors and chimneys must be installed in accordance with the manufacturer's instructions. The connector must be installed in a vertical position, and the chimney must be installed in a vertical position. The connector must be installed in a vertical position, and the chimney must be installed in a vertical position.

Connectors and chimneys must be installed in accordance with the manufacturer's instructions. The connector must be installed in a vertical position, and the chimney must be installed in a vertical position. The connector must be installed in a vertical position, and the chimney must be installed in a vertical position.

Connectors and chimneys must be installed in accordance with the manufacturer's instructions. The connector must be installed in a vertical position, and the chimney must be installed in a vertical position. The connector must be installed in a vertical position, and the chimney must be installed in a vertical position.

Connectors and chimneys must be installed in accordance with the manufacturer's instructions. The connector must be installed in a vertical position, and the chimney must be installed in a vertical position. The connector must be installed in a vertical position, and the chimney must be installed in a vertical position.

Connectors and chimneys must be installed in accordance with the manufacturer's instructions. The connector must be installed in a vertical position, and the chimney must be installed in a vertical position. The connector must be installed in a vertical position, and the chimney must be installed in a vertical position.

## Chimney Connectors

In general, following these guidelines will ensure compliance with all national and provincial codes. Prior to beginning your installation, check with your local building code official to check on additional local regulations which may influence the design and placement of your venting system.

The Harman 44 Magnum may be installed with (150 mm) 24 gauge chimney connector pipe. The size of the connector should correspond to the size of the flue collar opening. Do not use makeshift compromises. No part of the chimney connector may pass through an attic or roof space, closet or other concealed space, or through a floor or ceiling. Whenever possible, avoid passing the connector through a combustible wall. If you must, use an approved wall pass-through, described later in this section.

Assemble the connector beginning at the flue collar, with the crimped ends pointing towards the stove (to keep debris and creosote flakes inside the system). Each joint, including the one to the stove's flue collar and the one to the chimney itself should be **secured with at least three sheet metal screws**. A 1-1/4" (30 mm) overlap is required at each joint, including the flue collar attachment. No more than two 90 degree elbows should be used, and the total length of connector should not exceed 10 feet (3 m). All horizontal runs of connector must have a minimum upward slope of 1/4"(6 mm) per foot (20 mm per meter).

## Wall Pass-throughs

Occasionally it is necessary to pass the chimney connector through a combustible wall to reach the chimney. Depending on your local building codes, and the pertinent provincial or national codes, there are several choices for accomplishing this safely. Before beginning your installation, contact local officials, and also the chimney connector and chimney manufacturer for specific requirements.

*Canada.* Three methods are approved by the Canadian Standards Association. The diagram shows one method requiring an 18"(450 mm) air space between the connector and the wall. It allows use of one or two covers as described in the diagram. The two other methods are described in detail in the current issue of CAN/CSA B365, the national standard.

*United States* InThe NFPA (National Fire Protection Association) permits four methods for passing through a combustible wall. A commonly used method to pass through a wall directly to a masonry chimney is to clear a minimum 12"(300 mm) around the entire chimney connector, and fill it with brick masonry which is at least 3.5"(90 mm) thick. A fireclay liner, minimum 3/8"



1. 3 (0.9) ...  
 2. 6 (1.8) ...  
 3. 10 (3) ...  
 2 (60) ...  
 10 (30) ...

*Do not connect this unit to a chimney flue servicing another appliance.*

...  
 ...  
 ...  
 ...  
 ...

**Existing Masonry Chimneys**

...  
 ...  
 ...  
 ...  
 ...  
 ...

*Do not connect to any air distribution duct or system*

**Venting to a Masonry Chimney**

...  
 ...  
 ...  
 ...  
 ...  
 ...  
 ...  
 ...  
 ...  
 ...

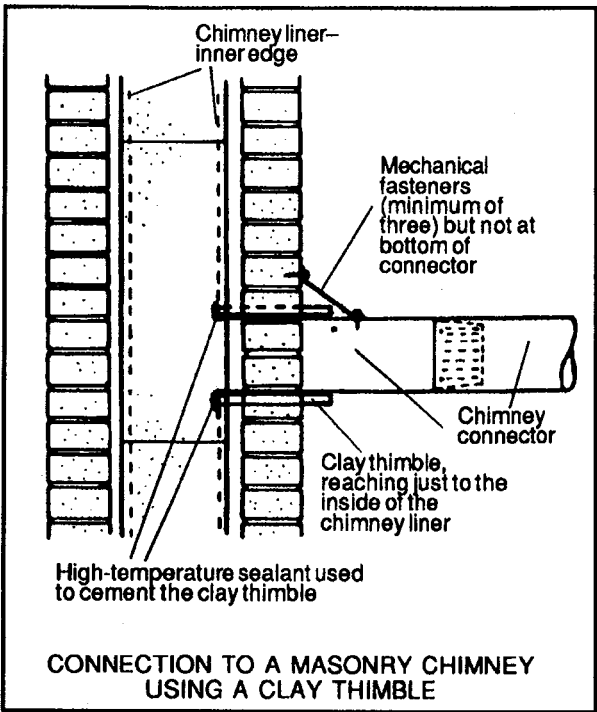

**CONNECTION TO A MASONRY CHIMNEY USING A CLAY THIMBLE**

...  
 ...  
 ...  
 ...  
 ...

**Venting to a Masonry Fireplace Chimney**

...  
 ...  
 ...  
 ...  
 ...  
 ...

...  
 ...  
 ...  
 ...  
 ...  
 ...

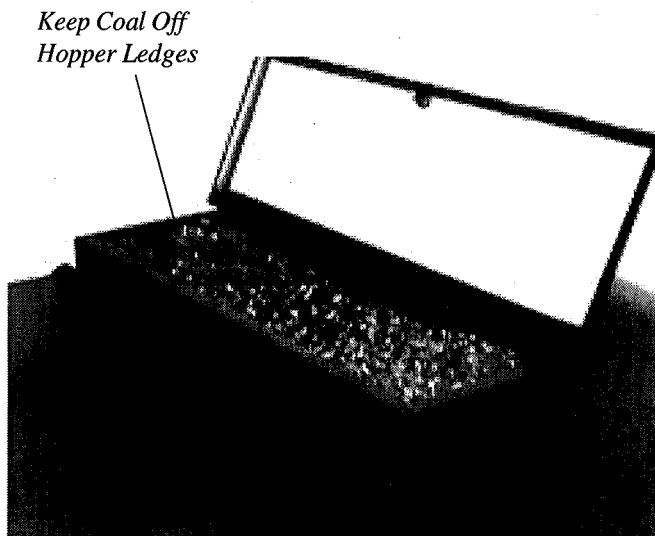

Fig.15

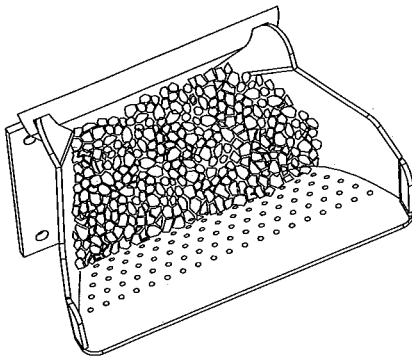

Fig.16

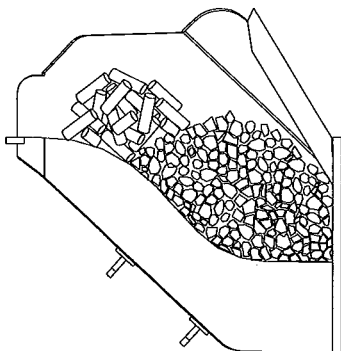

Fig.17

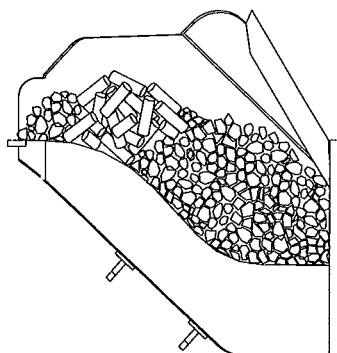

Fig.18

## Operation

Be sure the unit is plugged into a 120 V.A.C., 60 Hz receptacle.

## Test Motor Operation

Turn feed rate knob from off to TURBO. The combustion blower and feeder motor will run. Look at the end of the auger shaft in the bottom of the burn pot for rotation. Feel the air coming out of the burn pot hole for combustion blower operation.

Turn the fan control to high for distribution blower operation. If the test mode does not last long enough, simply recycle to OFF and back to TURBO.

## Starting a Fire

1. **Fill the hopper** with DRY coal (Rice sized anthracite or same sized low volatility bituminous coal).
2. **Fill the burn pot** with DRY coal so that it is level with the bottom row of holes. (The combustion air comes only from the burn pot holes; therefore, any starting material must be over the holes.) See Figure 16.
3. **Add desired starting material** (crushed charcoal, wood pellets, or manufactured coal starting block) over the remaining holes. See Figure 17. Wood pellets are shown in Figure 17.
4. **Add more DRY coal** around the starting material but not covering it. See Figure 18. Turning the knob passed the "OFF" position starts the combustion blower and makes the stove ready to light. The distribution blower and feed motor will also run for one minute or less just to let you know they are operational.
5. **Light the fire**, close all doors, and latch the hopper lid.
6. **Turn the feed rate knob** to a setting between #3 and #5, depending on how much air the starting material needs to burn properly to start the coal.
7. **Adjust the feed rate** to the desired setting when the coal is visibly burning.

Note: As the temperature of the fire increases, the distribution blower and feeder motor will start automatically.

The unit control has a fan limit which may briefly turn the distribution fan on high upon start up.

*"NEVER USE GASOLINE, GASOLINE-TYPE LANTERN FUEL, KEROSENE, CHARCOAL LIGHTER FLUID, OR SIMILAR LIQUIDS TO START OR 'FRESHEN UP' A FIRE IN THIS HEATER. KEEP ALL SUCH LIQUIDS WELL AWAY FROM THE HEATER WHILE IN USE."*

When the Feed Rate is set to "1" and the Blower is set to the lowest setting, only 75 watts of electricity are used.

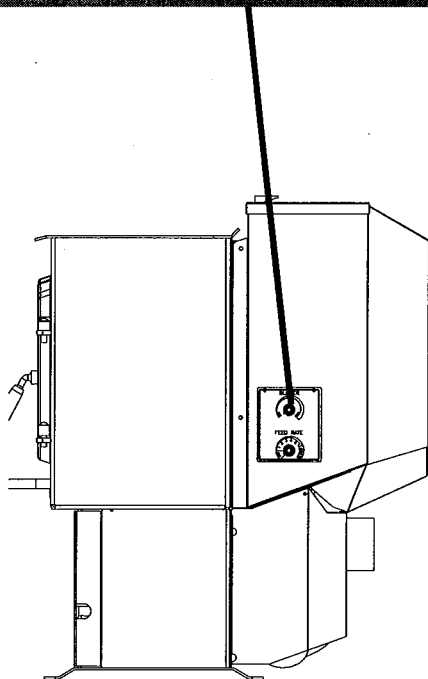

Fig. 19

## Turbo Control

After lighting the fire, the ESP probe in the exhaust senses when the temperature is high enough to start the feed motor and distribution blower.

The feed motor will start and stop as needed to maintain a fire relative to the dial setting of the feed rate.

### Turbo Range

Turning the feed rate knob into the Turbo range causes the feed rate to increase, providing extra heat not available in the normal range. It also causes the distribution blower to go to full speed. This is because you are asking for extra heat output; therefore, full blower speed is required.

### Blower Speed Adjustment

This knob adjusts the blower speed from "Low" to "Hi" as desired. When the feed rate is turned into the Turbo range, the blower automatically goes to high to force maximum heat into the room. The blower speed cannot be varied when in Turbo range.

When a thermostat is connected, the blower is controlled by heating demands.

### Thermostat ( optional )

When a thermostat is connected to the stove it controls the heat output. When the thermostat calls for heat, the feed rate and blower go to "max" just like in Turbo range. When the thermostat is satisfied, the feed rate and blower speed drop to the levels set on the dials.

### OFF

When the Feed Rate dial is turned to the OFF position the fire will slowly die and go out. When the stove cools down enough, all motors will stop.

If the stove runs out of coal and cools down, the control will shut down all but the combustion blower. The control must be turned to OFF to stop the combustion blower. Whenever the stove runs out of coal, the control must be turned to OFF and then back to the desired setting to reset the control for start-up.

### Test Mode

To use test mode, turn the feed rate to OFF and then to Turbo. This will cause all the motors to run for one minute or less in order to verify operation. If the test does not last long enough, simply recycle test mode.

Fig. 20



*Fine Tune Feed Adjuster  
(Shown with Covers Removed)*

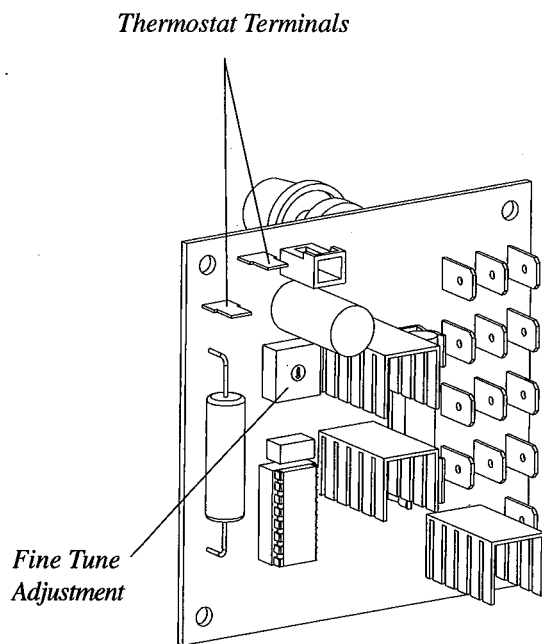

Fig. 21

**Warning**  
Always disconnect  
power before touching  
control board

## Fine tuning

### Feed Rate Fine Tuning

The 44 Magnum is equipped with a fine tune adjustment for the feed rate. This adjustment changes the output range of the stove from 44,000 btu high and 8000 btu low to 30,000 btu high and 6000 btu low.

This adjustment is set in the "High" position at the factory to provide maximum output.

The benefit of turning the adjustment to "Low" is that a hopper full of coal can last up to a week while a very low stove temperature is maintained.

Turning the adjuster clockwise increases the feed rate while turning it counterclockwise decreases it. Always stop with the adjuster handle pointing down.

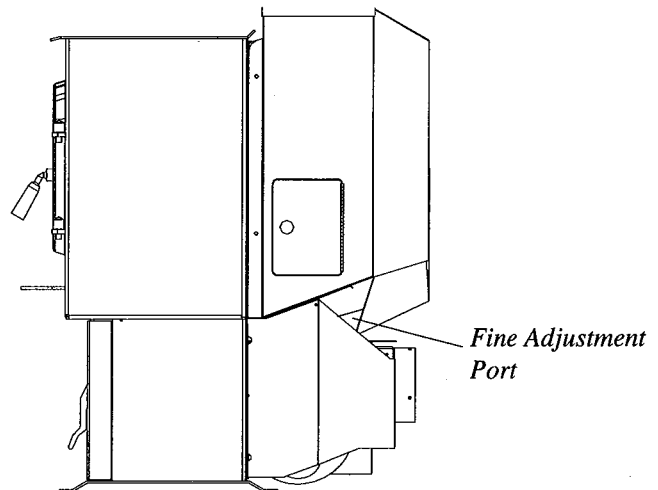

Fig. 22

### Low Combustion Air Fine Tune Adjustment

This adjustment should only be made by an authorized Harman dealer using a draft meter to check results. The Low Combustion Air Adjustment is set at the factory in the minimum position. This setting should give the proper combustion air with 118 V.A.C. 60 Hz or higher. This adjustment is only used if the voltage supplied to the stove is too low.





Fig. 23

Ash Pan

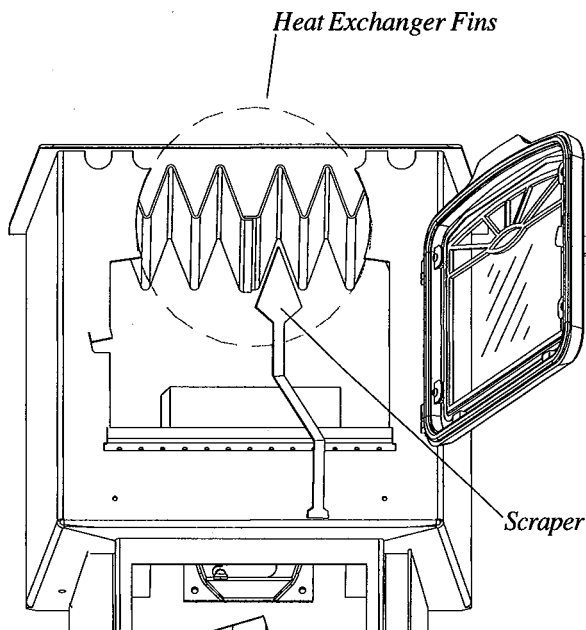

Fig. 24

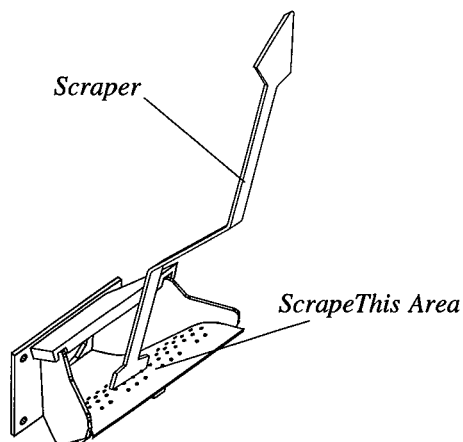

Fig. 25

**Removing Ashes:**

1. The ashes will need to be removed before the ash pan overflows. This will be necessary about once a day when on a high setting and approximately every four days when on lower settings.

2. It is recommended that the stove be cooled down and on a #1 setting.

3. Open the ash door, remove ash pan, and close the ash door while the ashes are being disposed of.

4. Replace the ash pan and turn the control to the desire setting.

Note: Make sure there are no ashes on the floor of the ash pan area. These ashes can build up behind the ash pan preventing the ash door from closing properly.

**Ashes should be placed in a metal container with a tight fitting lid. The closed container of ashes should be placed on a noncombustible floor or on the ground, well away from all combustible materials, pending final disposal. If ashes are disposed of by burial in soil or otherwise locally dispersed, they should be retained in the closed container until all cinders have thoroughly cooled.**

**Cleaning:**

The unit itself may not need to be cleaned until 1 1/2 to 2 tons of coal are burned.

The flue pipe itself may need to be checked bi-weekly or bi-monthly for flyash buildup. Bulk coal is usually a bit dirtier than bagged coal; therefore, it may require more frequent checking.

The unit should not have any coal in it to perform a proper cleaning.

1. Clean the heat exchanger with the scraper provided. See Figure 25.
2. Clean the inside surfaces with the end of the scraper or use a standard wire brush.
3. Clean the burn pot and scrape the inside surfaces to remove ash buildup.
4. Inspect the holes in the burn pot to see if they are all open. This ensures an efficient burn when all the holes are clean.

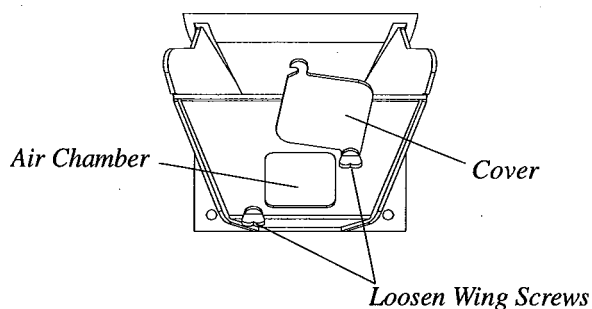

Fig. 26

5. Loosen wing screws and swing the burn pot clean out cover to the side. Clean out the air chamber and replace cover. See Figure 26.
6. Clean fly ash from flue area shown in fig. 27. Be careful not to damage the ESP Probe.

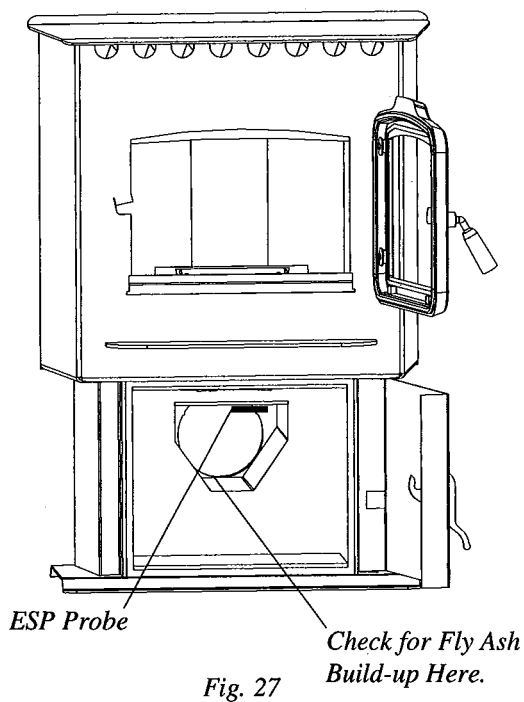

Fig. 27

## Soot Build-up

Soot residue accumulates on the flue lining as the products of combustion combine with moisture. This occurs when coal is burned. When coal is ignited, the soot residue creates an extremely hot fire.

During the heating season, both the chimney and the chimney connector need to be inspected at least every two months to determine if a soot build-up has occurred.

Soot accumulation must be removed to reduce the risk of a chimney fire.

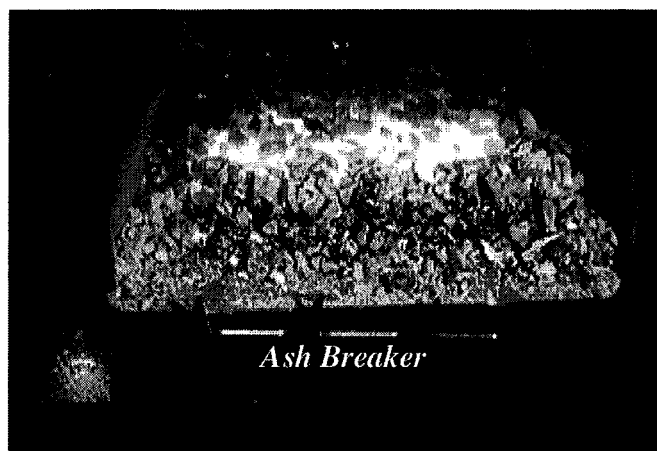

Fig. 28

## Ash Breaker

The 44 Magnum is equipped with an ash breaker that moves up and down in front of the burnpot. The breaker has teeth on it that break any klinkers (lumps of ash) and prevent any ash jamming. This allows the stove to be much shorter front to back.

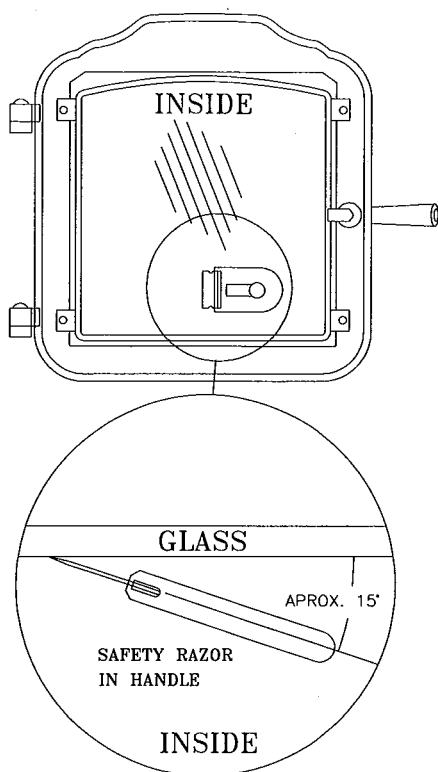

Fig. 29

### Cleaning Glass While Stove Is Operating

1. Turn the unit to LOW at setting #1 and allow the unit to cool down.
  2. Turn the unit to OFF. This will slow the combustion blower to it's lowest speed. Now the viewing door can be opened with minimal exhaust leakage.
  3. Use a safety razor in a handle to scrape the inside of the glass with the blade almost flat to the surface. See Figure 29. The window can now be cleaned with a liquid cleaner and a non-synthetic cloth.
- CAUTION: HOT GLASS MAY CAUSE THE CLEANER TO BOIL.**
4. Close the door and turn the unit back to the desired setting.

## TROUBLE SHOOTING

### Reasons the Feeder Might Not Feed

1. No coal in the hopper.
2. The unit has not reached 165 degrees Fahrenheit. The feed motor will not run until the ESP senses 165 degrees Fahrenheit on start up; therefore, if your starting fire did not get hot enough the feed motor will not start.
3. A foreign object may be in the hopper preventing the flow of coal.
4. The feed motor has failed.
5. The control board has failed.

### Reasons for Sulfur Smell or Carbon Monoxide Detector Sounding

1. Chimney draft is too low. Check chimney and chimney connector.
2. One or both of the doors are open.
3. Flue pipe might be blocked with flyash.

### Reasons the Fire Has Gone Out

1. No fuel in hopper.
2. The feed rate is too low.
3. A foreign object in the hopper is preventing the flow of coal.

4. The feed motor has failed.
5. The control board has failed.
6. The coal is too wet causing bridging in the hopper.
7. The feed rate knob is turned down so low that it is actually in the "OFF" position.
8. A fuse has blown.
9. Power failure has occurred.

### Low Heat Output

1. The coal too wet.
2. The fine tune feeder adjustment is turned all the way counterclockwise.
3. Poor quality coal.
4. Dirty combustion blower.
5. Partial blockage in the hopper.
6. Blocked burn pot holes.
7. Stove needs cleaned.

# 44 Magnum Feeder

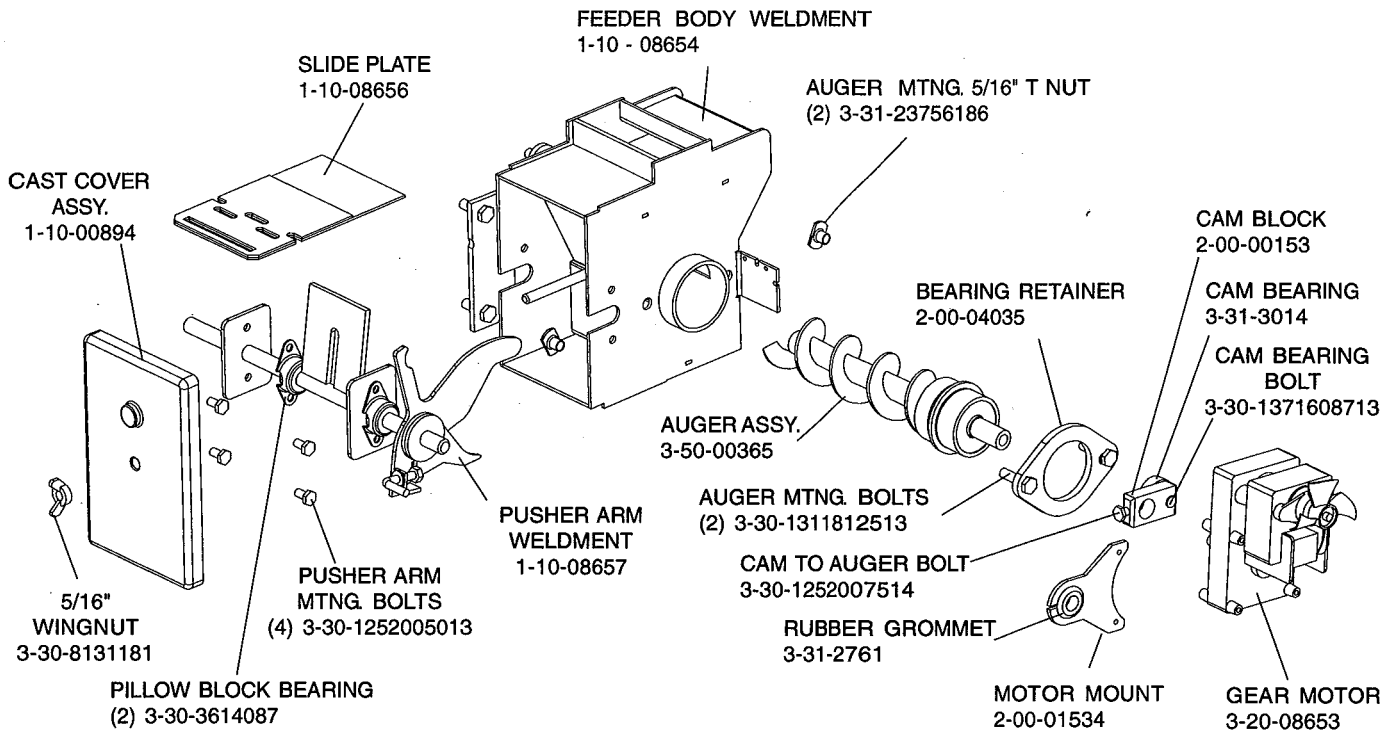

## Specifications

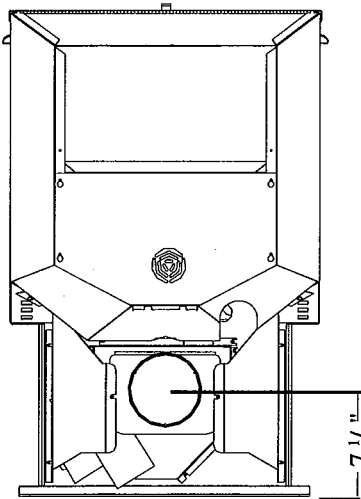

Fig. 30

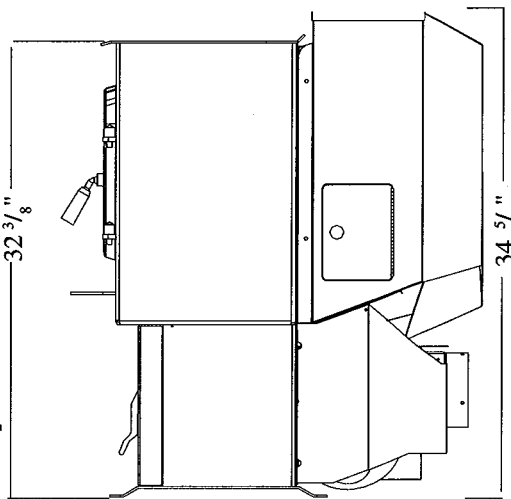

Fig. 31

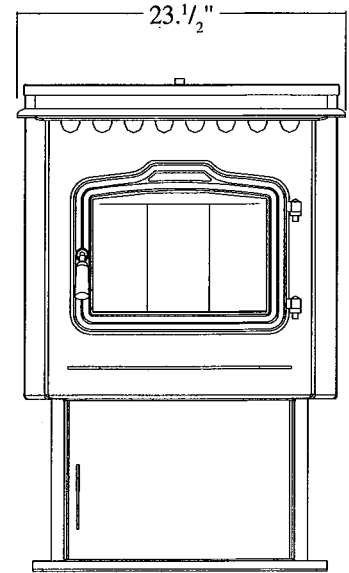

Fig. 32

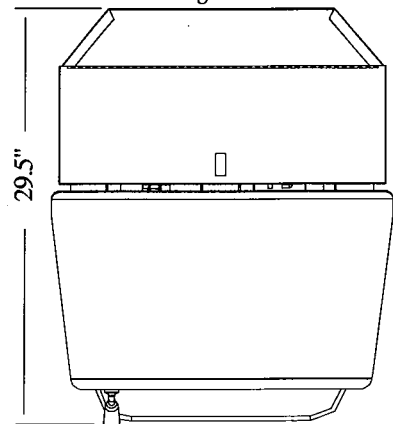
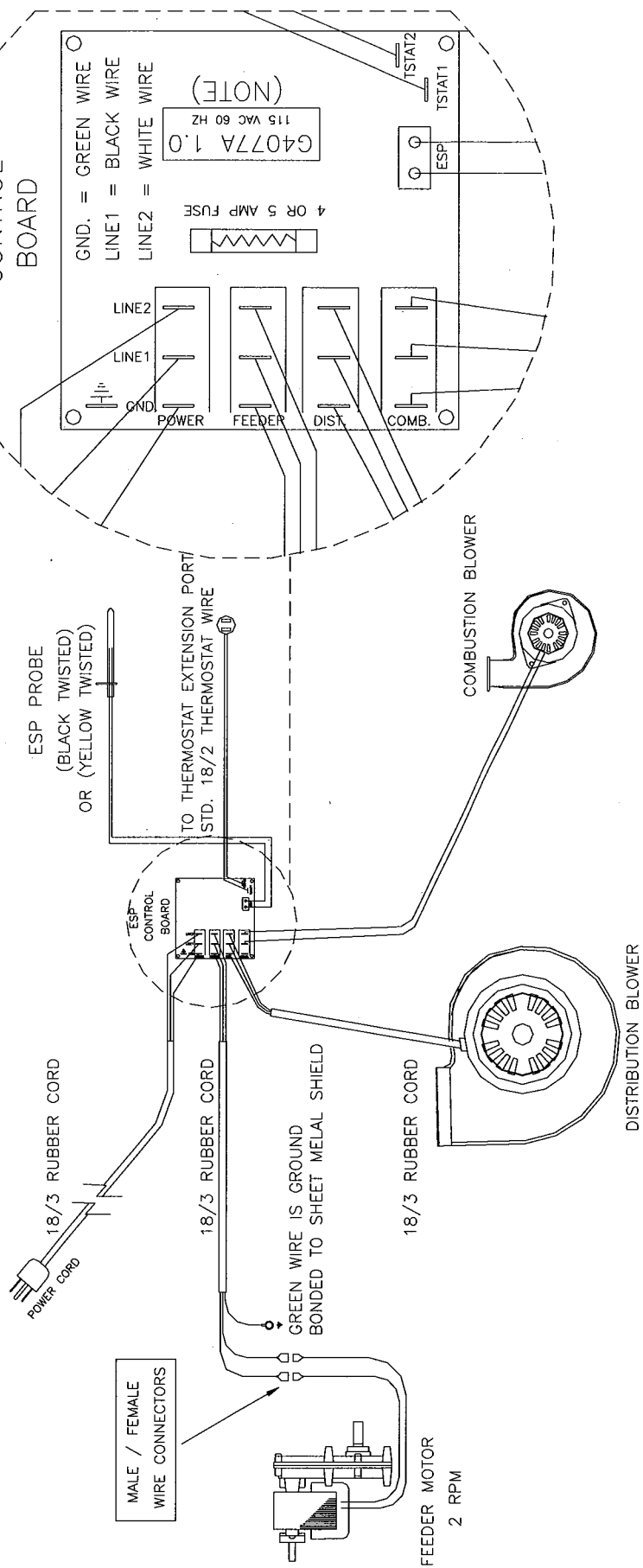

Fig. 33

<b>Weight</b>	<b>244 lbs.</b>
<b>Blower</b>	<b>135 cfm</b>
<b>Feed Rate</b>	<b>.55 to 3.75 lbs. per hr.</b>
<b>Hopper Capacity</b>	<b>86 lbs.</b>
<b>Fuel</b>	<b>Rice Sized Coal</b>
<b>Flue Size</b>	<b>5 inch</b>
<b>Fuse Rating</b>	<b>5 amp</b>

# Wiring Diagram

HARMAN 44MAG NATURAL DRAFT COAL STOKER WIRING DIAGRAM



300 WATTS --- 2.5 A. --- 120 VOLTS A.C. 60 HZ.

## Door Options

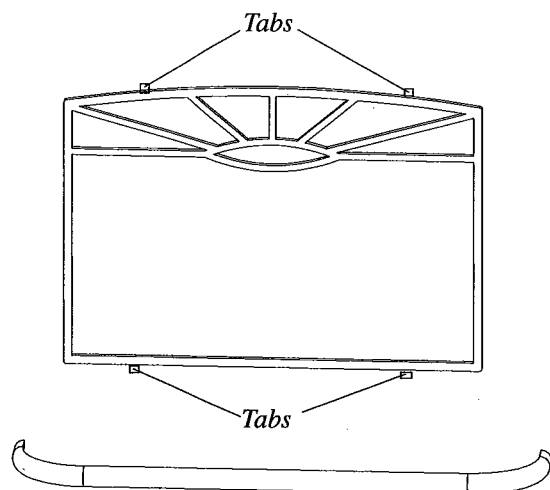

Fig. 34

### "Sunrise" Gold Trim

This kit includes a gold trim piece for the ash lip and a gold Sunrise piece for the door.

Referring to the diagram on page 5, note how the various components of the door system fit together. Lay the load door face down on a soft surface.

Clean the glass thoroughly using a nonabrasive glass cleaner. Install the glass gasket around the outer edge of the front face of the door glass carefully to insure proper sealing.

Note: There are 4 tabs on the Sunrise. These tabs have a step on the front side and are flush on the back side. Place the "Sunrise" in the door so the step side is to the front.

Set the glass pane gently onto the door. Install the hold-down clips and tighten with bolts as shown on page 5.

To install ash lip trim, simply slide the trim over the ash lip and into the groove on the trim.

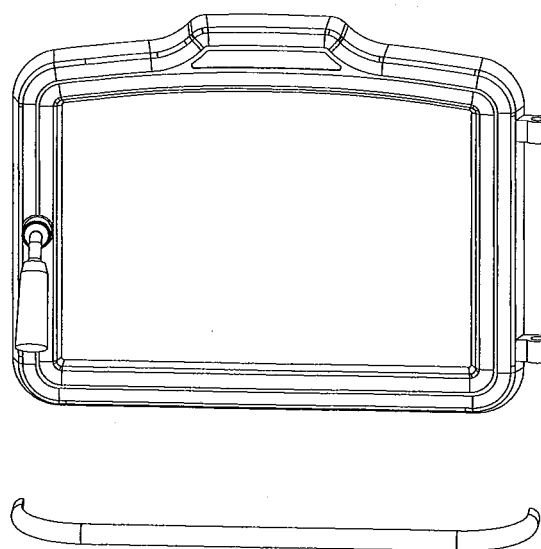

Fig. 35

### Gold Door

The gold door is assembled and installed the same as the standard door. Refer to page 5. Be careful not to scratch the glass. Remember to clean the gold before starting a fire in the stove.

To install ash lip trim, simply slide the trim over the ash lip and into the groove on the trim.

### Cleaning Gold

The gold plated door and gold Sunrise should never be buffed or polished. Abrasive cleansers and metal polishes will remove the plating and; therefore, should never be used. If the gold needs to be cleaned, wait until the stove is completely cool, then use a sponge, soap and water to gently remove dirt and stains. Before relighting the stove, remove all soap residue and wipe dry.

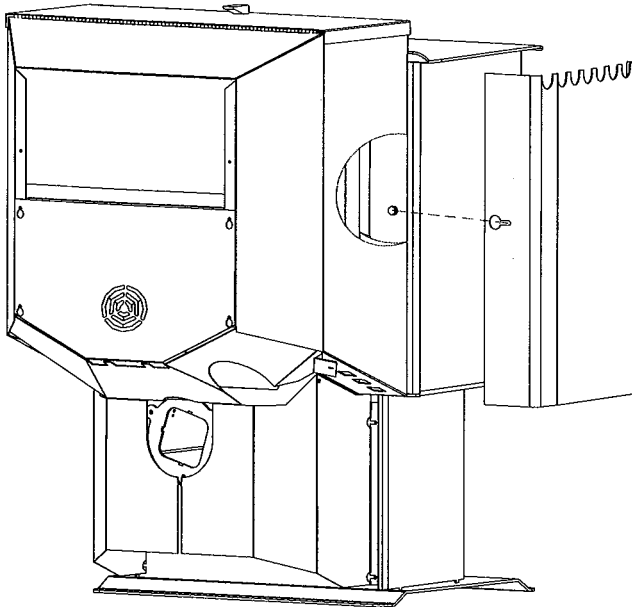

Fig. 36

### Side Heat Shields Installation

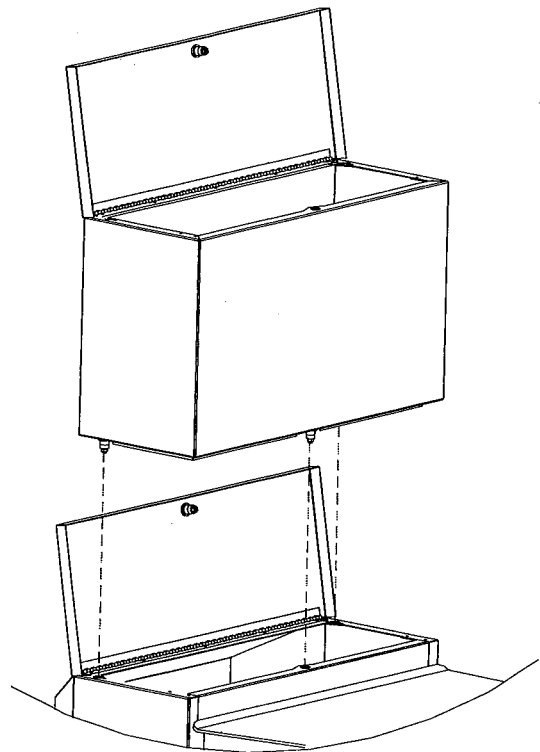

Fig. 37

### Hopper Extension Installation

## Thermostat (optional)

### What is a thermostat?

A thermostat is a switch that opens or closes at a set room temperature. For example: When you set the thermostat to 70 degrees, the switch will be closed causing the stove to burn on "Turbo" until the room temperature reaches 70 degrees. Then the switch will open, causing the stove to go to "low" which is where the feed rate is set.

### Installing A Thermostat

The thermostat should be mounted in a central location. Avoid isolated rooms with poor air circulation.

Run the thermostat wire (available at most hardware stores) from the thermostat to the rear of the unit and up to the thermostat terminals on the control board. See Fig. 21 on page 16. **Disconnect power before accessing control board.** The control board can be tilted out at the top to allow access to the thermostat terminals on the control board. Use the two female spade terminals (supplied) to make the connection.

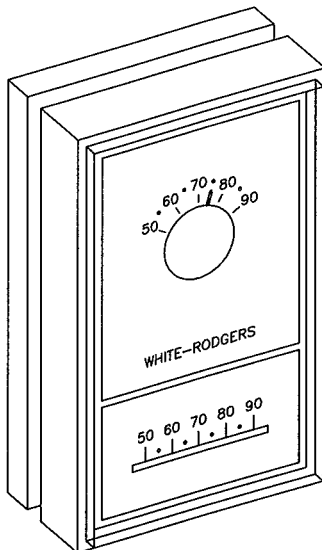

Fig. 38

# 44 MAG-N.D.

## ITEM NUMBER DESCRIPTION

0-88-00248	HOPPER GASKET— NEED 6'
1-00-08520-1	CLASSIC DOOR KIT “ BLACK “
1-00-08520-4	GOLD DOOR KIT W/ASH LIP
1-00-08617	ASH DOOR TILE FRAME
1-00-08631	HEAT SHIELD SET WITH BRASS TRIM
1-00-08636	HOPPER EXTENSION
1-00-773866	GOLD SUNRISE W/ASH LIP
1-10-05820	ASH PAN
1-10-08656	44M SLIDE PLATE ASSM, SS
1-10-08657	44M PUSHER ARM
1-10-08658	44M BURN POT ASSEMBLY
2-00-06526	44M ASH REMOVER FORK
2-00-773850	BURN POT SCRAPER
3-00-06553	FLAME GUIDE N.D.ONLY
3-20-00744	THERMISTER PROBE
3-20-04077	44M N.D. CIRCUIT BOARD
3-20-08653	FEEDER GEARMOTOR-2RPM
3-20-12080	THERMOSTAT - LOW VOLTAGE
3-21-60994993	DISTRIBUTION BLOWER
3-21-70219720	COMBUSTION BLOWER
3-30-625202501	1/4" 20* X 2 1/2" HANDLE BOLT
3-31-00968	CONTROL KNOB WHITE ON BLACK
3-31-00982	CONTROL KNOB SHAFT-WHITE
3-31-199110	SWELL LATCH “ HOPPER LID “
3-31-3614087	PILLOW BLOCK 1/2"
3-40-00121	BRASS ELBOW “ DOOR “
3-40-00122	WOODEN DOOR HANDLE
3-40-5647	CERAMIC LOG SET
3-40-950133125	DOOR GLASS
3-43-08400	BRASS ASH LIP
3-43-08648	GOLD LOUVER TRIM
3-43-120601/10	TILE PACK / YOU CHOOSE
3-44-00888	LOAD DOOR ROPE 3/8" MED. DENSITY
3-50-00365	AUGER ASSEMBLY
4-31-06393	PAWL BOLT



**HARMAN GOLD WARRANTY**  
**6 YEAR TRANSFERABLE LIMITED**  
**WARRANTY (Residential)**  
**1 YEAR LIMITED WARRANTY (Commercial)**



Harman Stove Company warrants its products to be free from defects in material or workmanship, in normal use and service, for a period of 6 years from the date of sales invoice and for mechanical and electrical failures, in normal use and service, for a period of 3 years from the date of sales invoice.

If defective in material or workmanship, during the warranty period, Harman Stove Company will, at its option, repair or replace the product as described below.

The warranty above constitutes the entire warranty with respect to Harman Stove Company products. HARMAN STOVE COMPANY MAKES NO OTHER WARRANTY, EXPRESSED OR IMPLIED, INCLUDING "ANY" WARRANTY OF MERCHANTABILITY, OR WARRANTY OF FITNESS FOR A PARTICULAR PURPOSE. No employee, agent, dealer, or other person is authorized to give any warranty on behalf of Harman Stove Company. This warranty does not apply if the product has been altered in any way after leaving the factory. Harman Stove Company and its agents assume no liability for "resultant damages of any kind" arising from the use of its products. In addition, the manufacturer and its warranty administrator shall be held free and harmless from liability from damage to property related to the operation, proper or improper, of the equipment.

THERE ARE NO WARRANTIES WHICH EXTEND BEYOND THE DESCRIPTION ON THE FACE HEREOF.

THESE WARRANTIES APPLY only if the device is installed and operated as recommended in the user's manual.

THESE WARRANTIES WILL NOT APPLY if abuse, accident, improper installation, negligence, or use beyond rated capacity causes damage.

HOW TO MAKE A CLAIM - Any claim under this warranty should be made to the dealer from whom this appliance was purchased. Then contact is made with manufacturer, giving the model and serial numbers, the date of purchase, your dealer's name and address, plus a simple explanation of the nature of the defect. Extra costs such as mileage and overtime are not covered. Nuisance calls are not covered by these warranties.

THIS WARRANTY IS LIMITED TO DEFECTIVE PARTS - REPAIR AND/OR REPLACEMENT AT HARMAN STOVE COMPANY'S OPTION AND EXCLUDES ANY INCIDENTAL AND CONSEQUENTIAL DAMAGES CONNECTED THEREWITH.

WARRANTY EXCLUSIONS: Failure due, but not limited to, fire, lightning, acts of God, power failures and/or surges, rust, corrosion and venting problems are not covered. Damage and/or repairs including but not limited to; remote controls, filters, fuses, knobs, glass, ceramic brick panels, ceramic fiber afterburners, door packing, tile, ceramic log sets, paint, batteries or battery back-up and related duct work are not covered. Also excluded from this warranty are consumable or normal wear items including but not limited to; flame guides, grates, coal bars, afterburner hoods, fire brick, gaskets. Additional exclusions for corn stoves are burnpot housing weldment, burnpot grate weldment (pellet or corn), burnpot front plate (pellet or corn), burnpot front plate lock, corn auger extension, ceramic insert, and ceramic insert plate. Additional or unusual utility bills incurred due to any malfunction or defect in equipment and the labor cost of gaining access to or removal of a unit that requires special tools or equipment are not covered. Maintenance needed to keep the stove in "good operating condition" is not covered. This includes, but is not limited to, cleaning, adjustment of customer controls and customer education. Labor, materials, expenses and/or equipment needed to comply with law and/or regulations set forth by any governmental agencies are not covered.

This Warranty provides specific legal rights and the consumer may have other rights that vary from state to state.

In the event of change in ownership, the remaining portion of this warranty may be transferred to the new owner by sending the new owner information to the Harman Stove Company.

PLEASE READ THE LITERATURE BY THE MANUFACTURER FOR THE VARIOUS ACCESSORY DEVICES. THE MANUFACTURER WARRANTS THESE ACCESSORY DEVICES, NOT HARMAN STOVE COMPANY OR THEIR WARRANTY ADMINISTRATOR. FURTHERMORE, THESE ACCESSORY DEVICES MUST BE INSTALLED AND USED ACCORDING TO THE RECOMMENDATIONS OF THE MANUFACTURER.

REMEDIES - The remedies set forth herein are exclusive and the liability of seller with respect to any contract or sale or anything done in connection therewith, whether in Contract, in tort, under any warranty, or otherwise, shall not, except as herein expressly provided, exceed the price of the equipment or part of which such liability is based.

CLARIFY - The above represents the complete warranty, which is given in connection with stoves, manufactured by Harman Stove Company. No other commitments, verbal or otherwise, shall apply except by a written addendum to this warranty.