

Model(s):

NEVO4236I

NEVO3630I

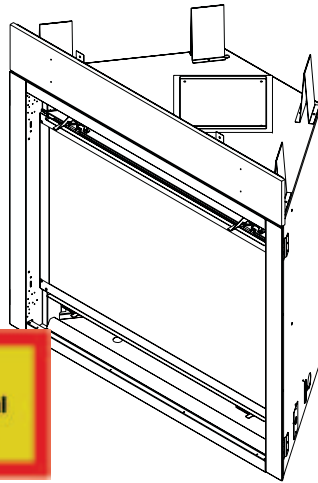

GAS-FIRED



This appliance has been retired.
For replacement parts, please refer to the individual
service parts list located on the brand websites.



CAUTION

DO NOT DISCARD THIS MANUAL



- Important operating and maintenance instructions included.
- Read, understand and follow these instructions for safe installation and operation.
- Leave this manual with party responsible for use and operation.

▲ WARNING:
FIRE OR EXPLOSION HAZARD
Failure to follow safety warnings exactly could result in serious injury, death, or property damage.

- **DO NOT** store or use gasoline or other flammable vapors and liquids in the vicinity of this or any other appliance.
- **What to do if you smell gas**
 - **DO NOT** try to light any appliance.
 - **DO NOT** touch any electrical switch. **DO NOT** use any phone in your building.
 - Leave the building immediately.
 - Immediately call your gas supplier from a neighbor's phone. Follow the gas supplier's instructions.
 - If you cannot reach your gas supplier, call the fire department.
- Installation and service must be performed by a qualified installer, service agency, or the gas supplier.

! DANGER



HOT GLASS WILL CAUSE BURNS.

DO NOT TOUCH GLASS UNTIL COOLED.

NEVER ALLOW CHILDREN TO TOUCH GLASS.

A barrier designed to reduce the risk of burns from the hot viewing glass is provided with this appliance and shall be installed for the protection of children and other at-risk individuals.

In the Commonwealth of Massachusetts installation must be performed by a licensed plumber or gas fitter; See Table of Contents for location of additional Commonwealth of Massachusetts requirements.

This appliance may be installed as an OEM installation in manufactured home (USA only) or mobile home and must be installed in accordance with the manufacturer's instructions and the *Manufactured Home Construction and Safety Standard, Title 24 CFR, Part 3280* in the United States, or the *Standard for Installation in Mobile Homes, CAN/CSA Z240 MH Series*, in Canada.

This appliance is only for use with the type(s) of gas indicated on the rating plate. This appliance is not convertible for use with other gases, unless a certified kit is used.

Read this manual before installing or operating this appliance.
Please retain this owner's manual for future reference.

A. Congratulations

Congratulations on selecting a Heatilator gas fireplace, an elegant and clean alternative to wood burning fireplaces. The Heatilator gas fireplace you have selected is designed to provide the utmost in safety, reliability, and efficiency.

As the owner of a new fireplace, you'll want to read and carefully follow all of the instructions contained in this owner's manual. Pay special attention to all cautions and warnings.

This owner's manual should be retained for future reference. We suggest that you keep it with your other important documents and product manuals.

The information contained in this owner's manual, unless noted otherwise, applies to all models and gas control systems.

Your new Heatilator gas fireplace will give you years of durable use and trouble-free enjoyment. Welcome to the Heatilator family of fireplace products!

Homeowner Reference Information	<i>We recommend that you record the following pertinent information about your fireplace.</i>
Model Name: _____	Date purchased/installed: _____
Serial Number: _____	Location on fireplace: _____
Dealership purchased from: _____	Dealer Phone: _____
Notes: _____	

Listing Label Information/Location

The model information regarding your specific fireplace can be found on the rating plate usually located in the control area of the fireplace.

heatilator
The first name in fireplaces

Heat & Glo, a brand of Hearth & Home Technologies
7571 215th Street West, Lakeville, MN 55044

GAS-FIRED
UL
LISTED

Not for use with solid fuel.
(Ne doit pas être utilisé avec un combustible solide).

Type of Gas (Sorte De Gaz): **NATURAL GAS**

This appliance must be installed in accordance with local codes, if any; if not, follow ANSI Z223.1 in the USA or CAN/CGA B149 installation codes. (Installer l'appareil selon les codes ou règlements locaux ou, en l'absence de tels règlements, selon les codes d'installation CAN/CGA-B149.)

ANSI Z21XX-XXXX - CSA 2.XX-MXX

Minimum Permissible Gas Supply for Purposes of Input Adjustment.

Approved Minimum (De Gaz) Acceptable	0.0 in w.c.	(Po. Col. d'eau)
Maximum Pressure (Pression)	0.0 in w.c.	(Po. Col. d'eau)
Maximum Manifold Pressure (Pression)	0.0 in w.c.	(Po. Col. d'eau)
Minimum Manifold Pressure (Pression)	0.0 in w.c.	(Po. Col. d'eau)

Total Electrical Requirements: 000Vac, 00Hz., less than 00 Amperes

MADE IN USA

ALTITUDE:	0-0000 FT.	IN CANADA	0000-0000FT.	Model:	XXXXXXXX
MAX. INPUT BTUH:	00,000		00,000	(Modele):	_____
MIN. INPUT BTUH:	00,000		00,000	Serial	XXXXXXXX
ORIFICE SIZE:	#XXXXX		#XXXXX	(Serie):	_____

▲ Safety Alert Key:

- **DANGER!** Indicates a hazardous situation which, if not avoided will result in death or serious injury.
- **WARNING!** Indicates a hazardous situation which, if not avoided could result in death or serious injury.
- **CAUTION!** Indicates a hazardous situation which, if not avoided, could result in minor or moderate injury.
- **NOTICE:** Used to address practices not related to personal injury.

Table of Contents

→	A. Congratulations	2	7 Vent Information and Diagrams	
	B. Limited Lifetime Warranty	5	A. Approved Pipe	24
1 Listing and Code Approvals			B. Vent Table Key	24
A. Appliance Certification	7		C. Use of Elbows	24
B. Tempered Glass Specifications	7		D. Measuring Standards	24
C. BTU Specifications	7		E. Vent Diagrams	25
D. High Altitude Installations	7	8 Vent Clearances and Framing		
E. Non-Combustible Materials Specification	7	A. Pipe Clearances to Combustibles	35	
F. Combustible Materials Specification	7	B. Wall Penetration Framing	35	
G. Electrical Codes	7	C. Install the Ceiling Firestop	36	
H. Requirements for the Commonwealth of Massachusetts	8	D. Install Attic Insulation Shield	36	
		9 Appliance Preparation		
		A. Top Vent	37	
		B. Rear Vent	38	
		C. Secure and Level the Appliance	39	
		10 Install Vent Pipe		
		A. Assemble Vent Sections (DVP Only)	40	
		B. Assemble Vent Sections (SLP Only)	41	
		C. Assemble Slip Sections	41	
		D. Secure the Vent Sections	42	
		E. Disassemble Vent Sections	42	
		F. Install Decorative Ceiling Components (SLP only)	43	
		G. Install Metal Roof Flashing	44	
		H. Assemble and Install Storm Collar	44	
		I. Install Vertical Termination Cap	45	
		J. Heat Shield Requirements for Horizontal Termination	45	
		K. Install Horizontal Termination Cap	46	
		11 Shrouds		
		A. HHT Shrouds	47	
		B. Field Constructed Shrouds	47	
		12 Gas Information		
		A. Fuel Conversion	49	
		B. Gas Pressure	49	
		C. Gas Connection	49	
		D. High Altitude Installations	49	
		13 Electrical Information		
		A. Wiring Requirements	50	
		B. IntelliFire™ Plus Ignition System Wiring	50	
		C. Optional Accessories Requirements	50	
		D. Electrical Service and Repair	51	←
		E. Junction Box Installation	52	
		F. Wall Switch Installation for Fan (Optional)	52	
		14 Finishing		
		A. Mantel and Wall Projections	53	
		B. Facing Material	54	

15 Appliance Setup

A. Remove the Packaging	55
B. Remove the Shipping Materials	55
C. Removing Fixed Glass Assembly	55
D. Remove Glass Media Package	55
E. Clean the Appliance	55
F. Accessories	55
G. Place the Glass Media	56
H. Replacing Fixed Glass Assembly	57
I. Air Shutter Setting	57

16 Troubleshooting

A. Intellifire™ Plus Intermittent Ignition System	58
---	----

17 Reference Materials

A. Appliance/Decorative Front Dimension Diagrams	60
B. Vent Components Diagrams	62
C. Service Parts	71
D. Optional Components	75
E. Contact Information	76

➔ = Contains updated information.

→ B. Limited Lifetime Warranty

**Hearth & Home Technologies
LIMITED LIFETIME WARRANTY**

Hearth & Home Technologies, on behalf of its hearth brands (“HHT”), extends the following warranty for HHT gas, wood, pellet, coal and electric hearth appliances that are purchased from an HHT authorized dealer.

WARRANTY COVERAGE:

HHT warrants to the original owner of the HHT appliance at the site of installation, and to any transferee taking ownership of the appliance at the site of installation within two years following the date of original purchase, that the HHT appliance will be free from defects in materials and workmanship at the time of manufacture. After installation, if covered components manufactured by HHT are found to be defective in materials or workmanship during the applicable warranty period, HHT will, at its option, repair or replace the covered components. HHT, at its own discretion, may fully discharge all of its obligations under such warranties by replacing the product itself or refunding the verified purchase price of the product itself. The maximum amount recoverable under this warranty is limited to the purchase price of the product. This warranty is subject to conditions, exclusions and limitations as described below.

WARRANTY PERIOD:

Warranty coverage begins on the date of original purchase. In the case of new home construction, warranty coverage begins on the date of first occupancy of the dwelling or six months after the sale of the product by an independent, authorized HHT dealer/ distributor, whichever occurs earlier. The warranty shall commence no later than 24 months following the date of product shipment from HHT, regardless of the installation or occupancy date. The warranty period for parts and labor for covered components is produced in the following table.

The term “Limited Lifetime” in the table below is defined as: 20 years from the beginning date of warranty coverage for gas appliances, and 10 years from the beginning date of warranty coverage for wood, pellet, and coal appliances. These time periods reflect the minimum expected useful lives of the designated components under normal operating conditions.

Warranty Period		HHT Manufactured Appliances and Venting							Components Covered
Parts	Labor	Gas	Wood	Pellet	EPA Wood	Coal	Electric	Venting	
1 Year		X	X	X	X	X	X	X	All parts and material except as covered by Conditions, Exclusions, and Limitations listed
2 years				X	X	X			Igniters, electronic components, and glass
		X	X	X	X	X			Factory-installed blowers
			X						Molded refractory panels
		X							Ignition Modules
3 years				X					Firepots and burnpots
5 years	1 year			X	X				Castings and baffles
7 years	3 years		X	X	X				Manifold tubes, HHT chimney and termination
10 years	1 year	X							Burners, logs and refractory
Limited Lifetime	3 years	X	X	X	X	X			Firebox and heat exchanger
90 Days		X	X	X	X	X	X	X	All replacement parts beyond warranty period

See conditions, exclusions, and limitations on next page.

→ B. Limited Lifetime Warranty (*continued*)

WARRANTY CONDITIONS:

- This warranty only covers HHT appliances that are purchased through an HHT authorized dealer or distributor. A list of HHT authorized dealers is available on the HHT branded websites.
- This warranty is only valid while the HHT appliance remains at the site of original installation.
- This warranty is only valid in the country in which the HHT authorized dealer or distributor that sold the appliance resides.
- Contact your installing dealer for warranty service. If the installing dealer is unable to provide necessary parts, contact the nearest HHT authorized dealer or supplier. Additional service fees may apply if you are seeking warranty service from a dealer other than the dealer from whom you originally purchased the product.
- Check with your dealer in advance for any costs to you when arranging a warranty call. Travel and shipping charges for parts are not covered by this warranty.

WARRANTY EXCLUSIONS:

This warranty does not cover the following:

- Changes in surface finishes as a result of normal use. As a heating appliance, some changes in color of interior and exterior surface finishes may occur. This is not a flaw and is not covered under warranty.
- Damage to printed, plated, or enameled surfaces caused by fingerprints, accidents, misuse, scratches, melted items, or other external sources and residues left on the plated surfaces from the use of abrasive cleaners or polishes.
- Repair or replacement of parts that are subject to normal wear and tear during the warranty period. These parts include: paint, wood, pellet and coal gaskets, firebricks, grates, flame guides, batteries and the discoloration of glass.
- Expansion, contraction, or movement of certain parts causing noise. These conditions are normal and complaints related to this noise are not covered by this warranty.
- Damages resulting from: (1) failure to install, operate, or maintain the appliance in accordance with the installation instructions, operating instructions, and listing agent identification label furnished with the appliance; (2) failure to install the appliance in accordance with local building codes; (3) shipping or improper handling; (4) improper operation, abuse, misuse, continued operation with damaged, corroded or failed components, accident, or improperly/incorrectly performed repairs; (5) environmental conditions, inadequate ventilation, negative pressure, or drafting caused by tightly sealed constructions, insufficient make-up air supply, or handling devices such as exhaust fans or forced air furnaces or other such causes; (6) use of fuels other than those specified in the operating instructions; (7) installation or use of components not supplied with the appliance or any other components not expressly authorized and approved by HHT; (8) modification of the appliance not expressly authorized and approved by HHT in writing; and/or (9) interruptions or fluctuations of electrical power supply to the appliance.
- Non-HHT venting components, hearth components or other accessories used in conjunction with the appliance.
- Any part of a pre-existing fireplace system in which an insert or a decorative gas appliance is installed.
- HHT's obligation under this warranty does not extend to the appliance's capability to heat the desired space. Information is provided to assist the consumer and the dealer in selecting the proper appliance for the application. Consideration must be given to appliance location and configuration, environmental conditions, insulation and air tightness of the structure.

This warranty is void if:

- The appliance has been over-fired or operated in atmospheres contaminated by chlorine, fluorine, or other damaging chemicals. Over-firing can be identified by, but not limited to, warped plates or tubes, rust colored cast iron, bubbling, cracking and discoloration of steel or enamel finishes.
- The appliance is subjected to prolonged periods of dampness or condensation.
- There is any damage to the appliance or other components due to water or weather damage which is the result of, but not limited to, improper chimney or venting installation.

LIMITATIONS OF LIABILITY:

- The owner's exclusive remedy and HHT's sole obligation under this warranty, under any other warranty, express or implied, or in contract, tort or otherwise, shall be limited to replacement, repair, or refund, as specified above. In no event will HHT be liable for any incidental or consequential damages caused by defects in the appliance. Some states do not allow exclusions or limitation of incidental or consequential damages, so these limitations may not apply to you. This warranty gives you specific rights; you may also have other rights, which vary from state to state. EXCEPT TO THE EXTENT PROVIDED BY LAW, HHT MAKES NO EXPRESS WARRANTIES OTHER THAN THE WARRANTY SPECIFIED HEREIN. THE DURATION OF ANY IMPLIED WARRANTY IS LIMITED TO DURATION OF THE EXPRESSED WARRANTY SPECIFIED ABOVE.

1 Listing and Code Approvals

A. Appliance Certification

MODELS: NEVO4236I, NEVO3630I

LABORATORY: Underwriters Laboratories, Inc. (UL)

TYPE: Vented Gas Fireplace Heaters

STANDARD: ANSI Z21.88-2014 • CSA 2.33-2014

This product is listed to ANSI standards for “Vented Gas Fireplace Heaters” and applicable sections of “Gas Burning Heating Appliances for Manufactured Homes and Recreational Vehicles”, and “Gas Fired Appliances for Use at High Altitudes”.

NOTICE: *This installation must conform with local codes. In the absence of local codes you must comply with the National Fuel Gas Code, ANSI Z223.1-latest edition in the U.S.A. and the CAN/CGA B149 Installation Codes in Canada.*

NOT INTENDED FOR USE AS A PRIMARY HEAT SOURCE.

This appliance is tested and approved as either supplemental room heat or as a decorative appliance. It should not be factored as primary heat in residential heating calculations.

B. Tempered Glass Specifications

This appliance is manufactured with tempered glass and may be installed in hazardous locations such as bathtub enclosures as defined by the Consumer Product Safety Commission (CPSC). The tempered glass has been tested and certified to the requirements of **ANSI Z97.1** and **CPSC 16 CFR 1202** (Safety Glazing Certification Council **SGCC# 1595** and **1597**. Architectural Testing, Inc. Reports **02-31919.01** and **02-31917.01**).

This statement is in compliance with **CPSC 16 CFR Section 1201.5** “Certification and labeling requirements” which refers to **15 U.S. Code (USC) 2063** stating “...Such certificate shall accompany the product or shall otherwise be furnished to any distributor or retailer to whom the product is delivered.”

Some local building codes require the use of tempered glass with permanent marking in such locations. Glass meeting this requirement is available from the factory. Please contact your dealer or distributor to order.

C. BTU Specifications

Novus	NEVO3630I	NEVO4236I
Max/Min Input Rate (NG)	20,000/10,000	25,000/12,500
Orifice Size (NG)	0.083	0.089 / #43
Max/Min Input Rate (LP)	20,000/10,000	23,000/11,500
Orifice Size (LP)	0.053	0.055 / #54

D. High Altitude Installations

NOTICE: *If the heating value of the gas has been reduced, these rules do not apply. Check with your local gas utility or authorities having jurisdiction.*

When installing above 2000 feet elevation:

- In the USA: Reduce input rate 4% for each 1000 feet above 2000 feet.
- In CANADA: Reduce input rate 10% for elevations between 2000 feet and 4500 feet. Above 4500 feet, consult local gas utility.

Check with your local gas utility to determine proper orifice size.

E. Non-Combustible Materials Specification

Material which will not ignite and burn. Such materials are those consisting entirely of steel, iron, brick, tile, concrete, slate, glass or plasters, or any combination thereof.

Materials that are reported as passing **ASTM E 136, Standard Test Method for Behavior of Materials in a Vertical Tube Furnace at 750 °C** shall be considered non-combustible materials.

F. Combustible Materials Specification

Materials made of or surfaced with wood, compressed paper, plant fibers, plastics, or other material that can ignite and burn, whether flame proofed or not, or plastered or unplastered shall be considered combustible materials.

G. Electrical Codes

NOTICE: *This appliance must be electrically wired and grounded in accordance with local codes or, in the absence of local codes, with National Electric Code ANSI/NFPA 70-latest edition or the Canadian Electric Code CSA C22.1.*

- A 120 VAC circuit for this product must be protected with ground-fault circuit-interrupter protection, in compliance with the applicable electrical codes, when it is installed in locations such as in bathrooms or near sinks.

Note: The following requirements reference various Massachusetts and national codes not contained in this document.

H. Requirements for the Commonwealth of Massachusetts

For all side wall horizontally vented gas fueled equipment installed in every dwelling, building or structure used in whole or in part for residential purposes, including those owned or operated by the Commonwealth and where the side wall exhaust vent termination is less than seven (7) feet above finished grade in the area of the venting, including but not limited to decks and porches, the following requirements shall be satisfied:

Installation of Carbon Monoxide Detectors

At the time of installation of the side wall horizontal vented gas fueled equipment, the installing plumber or gas fitter shall observe that a hard wired carbon monoxide detector with an alarm and battery back-up is installed on the floor level where the gas equipment is to be installed. In addition, the installing plumber or gas fitter shall observe that a battery operated or hard wired carbon monoxide detector with an alarm is installed on each additional level of the dwelling, building or structure served by the side wall horizontal vented gas fueled equipment. It shall be the responsibility of the property owner to secure the services of qualified licensed professionals for the installation of hard wired carbon monoxide detectors.

In the event that the side wall horizontally vented gas fueled equipment is installed in a crawl space or an attic, the hard wired carbon monoxide detector with alarm and battery back-up may be installed on the next adjacent floor level.

In the event that the requirements of this subdivision can not be met at the time of completion of installation, the owner shall have a period of thirty (30) days to comply with the above requirements; provided, however, that during said thirty (30) day period, a battery operated carbon monoxide detector with an alarm shall be installed.

Approved Carbon Monoxide Detectors

Each carbon monoxide detector as required in accordance with the above provisions shall comply with NFPA 720 and be ANSI/UL 2034 listed and IAS certified.

Signage

A metal or plastic identification plate shall be permanently mounted to the exterior of the building at a minimum height of eight (8) feet above grade directly in line with the exhaust vent terminal for the horizontally vented gas fueled heating appliance or equipment. The sign shall read, in print size no less than one-half (1/2) in. in size, **“GAS VENT DIRECTLY BELOW. KEEP CLEAR OF ALL OBSTRUCTIONS”**.

Inspection

The state or local gas inspector of the side wall horizontally vented gas fueled equipment shall not approve the installation unless, upon inspection, the inspector observes carbon monoxide detectors and signage installed in accordance with the provisions of 248 CMR 5.08(2)(a)1 through 4.

Exemptions

The following equipment is exempt from 248 CMR 5.08(2)(a)1 through 4:

- The equipment listed in Chapter 10 entitled “Equipment Not Required To Be Vented” in the most current edition of NFPA 54 as adopted by the Board; and
- Product Approved side wall horizontally vented gas fueled equipment installed in a room or structure separate from the dwelling, building or structure used in whole or in part for residential purposes.

MANUFACTURER REQUIREMENTS

Gas Equipment Venting System Provided

When the manufacturer of Product Approved side wall horizontally vented gas equipment provides a venting system design or venting system components with the equipment, the instructions provided by the manufacturer for installation of the equipment and the venting system shall include:

- Detailed instructions for the installation of the venting system design or the venting system components; and
- A complete parts list for the venting system design or venting system.

Gas Equipment Venting System NOT Provided

When the manufacturer of a Product Approved side wall horizontally vented gas fueled equipment does not provide the parts for venting the flue gases, but identifies “special venting systems”, the following requirements shall be satisfied by the manufacturer:

- The referenced “special venting system” instructions shall be included with the appliance or equipment installation instructions; and
- The “special venting systems” shall be Product Approved by the Board, and the instructions for that system shall include a parts list and detailed installation instructions.

A copy of all installation instructions for all Product Approved side wall horizontally vented gas fueled equipment, all venting instructions, all parts lists for venting instructions, and/or all venting design instructions shall remain with the appliance or equipment at the completion of the installation.

See Gas Connection section for additional Commonwealth of Massachusetts requirements.

User Guide

2 Operating Instructions

A. Gas Fireplace Safety

WARNING! DO NOT operate fireplace before reading and understanding operating instructions. Failure to operate fireplace according to operating instructions could cause fire or injury.



HOT GLASS WILL CAUSE BURNS.

DO NOT TOUCH GLASS UNTIL COOLED.

NEVER ALLOW CHILDREN TO TOUCH GLASS.

- Keep children away.
- CAREFULLY SUPERVISE children in same room as fireplace.
- Alert children and adults to hazards of high temperatures.

High temperatures may ignite clothing or other flammable materials.

- Clothing, furniture, draperies, and other flammable materials must not be placed on or near the appliance.

A barrier designed to reduce the risk of burns from the hot viewing glass is provided with this appliance and shall be installed for the protection of children and other at-risk individuals. DO NOT operate the appliance with the barrier removed. If the barrier becomes damaged, the barrier shall be replaced with the manufacturer's barrier for this appliance.

Contact your dealer or Hearth & Home Technologies if the barrier is not present or help is needed to properly install one.

Young children should be carefully supervised when they are in the same room as the appliance. Toddlers, young children and others may be susceptible to accidental contact burns.

- A physical barrier is recommended if there are at risk individuals in the house.
- To restrict access to a fireplace or stove, install an adjustable safety gate to keep toddlers, young children and other at risk individuals out of the room and away from hot surfaces.
- Install a switch lock or a wall/remote control with child protection lockout feature.
- Keep remote controls out of reach of children.
- Never leave children alone near a hot fireplace, whether operating or cooling down.

- Teach children to NEVER touch the fireplace.
- Consider not using the fireplace when children will be present.

Contact your dealer for more information, or visit: www.hpba.org/safety-information.

To prevent unintended operation when not using your fireplace for an extended period of time (summer months, vacations, trips, etc):

- Remove batteries from remote controls.
- Turn off wall controls.
- Unplug 6-volt power supply and/or remove batteries.
- Turn off gas controls valve on standing pilot models.

B. Your Fireplace

WARNING! DO NOT operate fireplace before reading and understanding operating instructions. Failure to operate fireplace according to operating instructions could cause fire or injury.

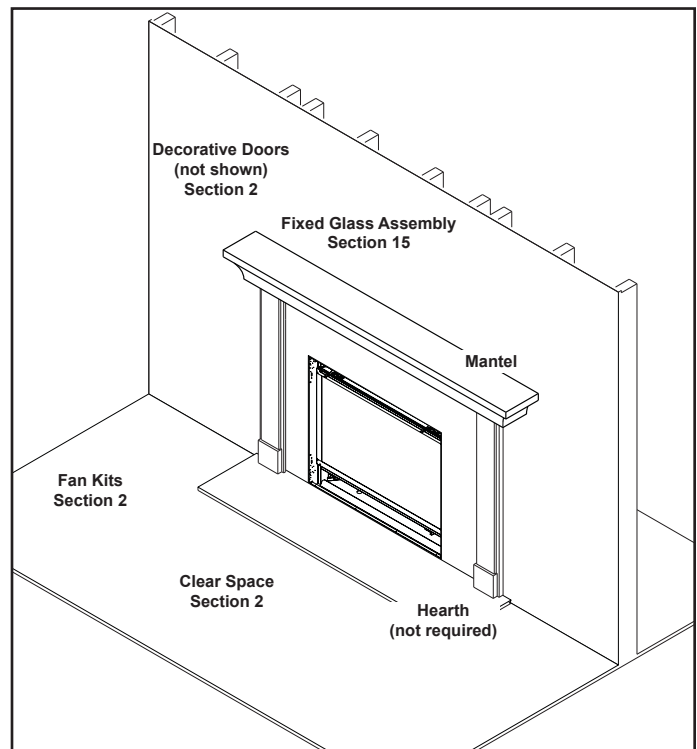

Figure 2.1 General Operating Parts

C. Fan Kit (optional)

If desired, a fan kit may be added. Contact your dealer to order the correct fan kit.

D. Clear Space

WARNING! DO NOT place combustible objects in front of the fireplace. High temperatures may start a fire. See Figure 2.2.

Avoid placing candles and other heat-sensitive objects on mantel or hearth. Heat may damage these objects.

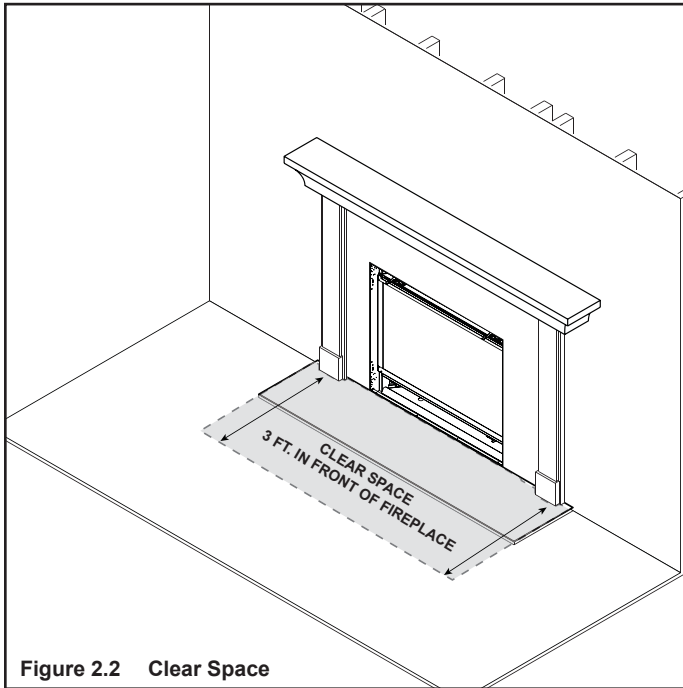

Figure 2.2 Clear Space

E. Decorative Doors and Fronts

WARNING! Risk of Fire! Install **ONLY** doors or fronts approved by *Hearth & Home Technologies*. Unapproved doors or fronts may cause fireplace to overheat.

*This fireplace has been supplied with an integral barrier to prevent direct contact with the fixed glass panel. **DO NOT** operate the fireplace with the barrier removed.*

Contact your dealer or *Hearth & Home Technologies* if the barrier is not present or help is needed to properly install one.

For more information refer to the instructions supplied with your decorative door or front.

F. Fixed Glass Assembly

See Section 15.D.

G. Remote Controls, Wall Controls and Wall Switches

Follow the instructions supplied with the control installed to operate your fireplace:

For safety:

- Install a switch lock or a wall/remote control with child protection lockout feature.
- Keep remote controls out of reach of children.

See your dealer if you have questions.

H. IPI Battery Tray/Battery Installation

The IntelliFire™ Plus system has a battery backup option. Battery longevity and performance will be affected by the service temperatures of this appliance..

NOTICE: Batteries should only be used as a power source in the event of an emergency such as an outage.

I. Control Module Operation

1. The control module has an ON/OFF/REMOTE selector switch that must be set. See Figure 2.3.

OFF Position: Appliance will ignore all power inputs and will not respond to any commands from a wall switch or remote. The unit should be in the OFF position during installation, service, battery installation, fuel conversion, and in the event that the control goes into LOCK-OUT mode as a result of an error code.

ON Position: Appliance will ignite and run continuously in the HI flame setting, with no adjustment in flame output. This mode of operation is primarily used for initial installation or power outage operation with battery backup.

REMOTE Position: Appliance will initiate commands from an optional wired wall switch and/or the wireless remote (RC300).

2. If using a wired wall switch with the module in REMOTE mode, the flame output can be adjusted with the HI/LO selector switch on the module. See Figure 2.3. Note that the flame HI/LO selector switch will become inactive once an optional remote control (RC200/RC300) is programmed to the control module. Note that the control module will always ignite the fireplace on HI and remain so for the initial 10 seconds of operation. If the HI/LO is switched to the LO position, the flame output will automatically drop to the lowest setting after the flame has been established for 10 sec. After this 10 second period, the flame can be adjusted from HI to LO with the switch.
3. The control module has safety feature that automatically shuts down the fireplace after 9 hours of continuous operation without receiving a command from the RC300 remote.
4. If you intend to use both an optional wired wall switch and the RC300 remote control to operate your fireplace, the wall switch will override any commands given by the remote.
5. **Module Reset**

This module may lock-out under certain conditions. When this occurs, the appliance will not ignite or respond to commands. The module will go into lock-out mode by emitting three audible beeps, then continuously displaying a RED/GREEN error code at its status indicator LED.

 - Check battery tray. Remove batteries if installed. Batteries should only be installed for use during power outages. See Section H.

- Locate the module selector switch. (See Figure 2.3).
- Set the module selector switch to the OFF position.
- Wait five (5) minutes to allow possible accumulated gas to clear.
- Set the module selector switch to ON or REMOTE position.
- Start the appliance.

WARNING! Risk of Explosion! DO NOT reset the module more than one time more than one time within a five minute time period. Gas may accumulate in firebox. Call a qualified service technician.

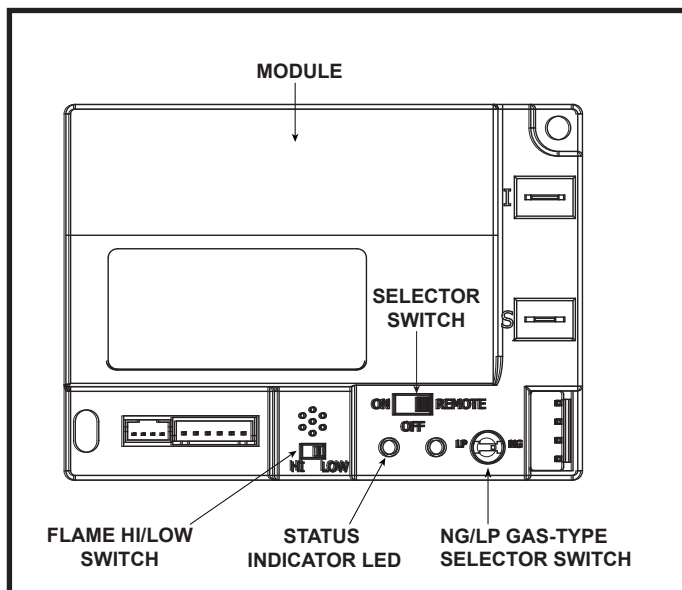

Figure 2.3 Control Module

Nine Hour Safety Shutdown Feature

This appliance has a safety feature that automatically shuts down the fireplace after 9 hours of continuous operation without receiving a command from the RC300 remote.

J. Before Lighting Fireplace

Before operating this fireplace for the first time, **have a qualified service technician:**

- Verify all shipping materials have been removed from inside and/or underneath the firebox.
- Review proper placement of logs, rockwool and/or other decorative materials.
- Check the wiring.
- Check the air shutter adjustment.
- Ensure that there are no gas leaks.
- Ensure that the glass is sealed and in the proper position and that the integral barrier is in place.

WARNING! Risk of Fire or Asphyxiation! DO NOT operate fireplace with fixed glass assembly removed.

K. Lighting Instructions (IPI)

FOR YOUR SAFETY READ BEFORE LIGHTING



WARNING: If you do not follow these instructions exactly, a fire or explosion may result causing property damage, personal injury or loss of life.

- A. This appliance is equipped with an intermittent pilot ignition (IPI) device which automatically lights the burner. **DO NOT** try to light the burner by hand.
 - B. **BEFORE LIGHTING**, smell all around the appliance area for gas. Be sure to smell next to the floor because some gas is heavier than air and will settle on the floor.
 - C. Use only your hand to push in or turn the gas control knob. Never use tools. If the knob will not push in or turn by hand, **DO NOT** try to repair it, call a qualified service technician. Force or attempted repair may result in a fire or explosion.
 - D. **DO NOT** use this appliance if any part has been under water. Immediately call a qualified service technician to inspect the appliance and to replace any part of the control system and any gas control which has been under water.
- WHAT TO DO IF YOU SMELL GAS**
- **DO NOT** try to light any appliance.
 - **DO NOT** touch any electric switch; do not use any phone in your building.
 - Immediately call your gas supplier from a neighbor's phone. Follow the gas supplier's instructions.
 - If you cannot reach your gas supplier, call the fire department.

LIGHTING INSTRUCTIONS (IPI)

1. This appliance is equipped with an ignition device which automatically lights the burner. **DO NOT** try to light the burner by hand.
2. Wait five (5) minutes to clear out any gas. Then smell for gas, including near the floor. If you smell gas, **STOP!** Follow "B" in the Safety Information located on the top of this label. If you do not smell gas, go to next step.
3. To light the burner:
Equipped with wall switch: Turn ON/OFF switch to ON.
Equipped with remote or wall control: Press ON or FLAME button.
Equipped with thermostat: Set temperature to desired setting.
4. If the appliance does not light after three tries, call your service technician or gas supplier.

**GAS
VALVE**

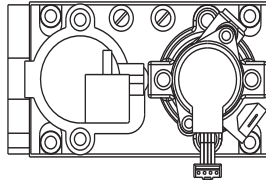

TO TURN OFF GAS TO APPLIANCE

1. Equipped with wall switch: Turn ON/OFF switch to OFF.
Equipped with remote or wall control: Press OFF button.
Equipped with thermostat: Set temperature to lowest setting.
2. Service technician should turn off electric power to the control when performing service.



DANGER



**HOT GLASS WILL CAUSE BURNS.
DO NOT TOUCH GLASS UNTIL COOLED.
NEVER ALLOW CHILDREN TO TOUCH GLASS.**

A barrier designed to reduce the risk of burns from the hot viewing glass is provided with this appliance and shall be installed for the protection of children and other at-risk individuals.

WARNING:

DO NOT CONNECT LINE VOLTAGE (110/120 VAC OR 220/240 VAC) TO THE CONTROL VALVE.

Improper installation, adjustment, alteration, service or maintenance can cause injury or property damage. Refer to the owner's information manual provided with this appliance. For assistance or additional information, consult a qualified installer, service agency or the gas supplier.

This appliance needs fresh air for safe operation and must be installed so there are provisions for adequate combustion and ventilation air.

If not installed, operated, and maintained in accordance with the manufacturer's instructions, this product could expose you to substances in fuel or fuel combustion which are known to the State of California to cause cancer, birth defects, or other reproductive harm.

Keep burner and control compartment clean. See installation and operating instructions accompanying appliance.

CAUTION:

Hot while in operation. **DO NOT** touch. Keep children, clothing, furniture, gasoline and other liquids having flammable vapors away.

DO NOT operate the appliance with fixed glass assembly removed, cracked or broken. Replacement of the fixed glass assembly should be done by a licensed or qualified service person.

NOT FOR USE WITH SOLID FUEL

For use with natural gas and propane. A conversion kit, as supplied by the manufacturer, shall be used to convert this appliance to the alternate fuel.

Also Certified for Installation in a Bedroom or a Bedsitting Room.

This appliance must be installed in accordance with local codes, if any; if none, follow the *National Fuel Gas Code, ANSIZ223.1/NFPA 54, or the National Gas and Propane Installation code, CSA B149.1.*

For additional information on operating your
Hearth & Home Technologies fireplace, please refer to www.fireplaces.com.

593-913i

L. After Fireplace is Lit

Initial Break-in Procedure

- The fireplace should be run three to four hours continuously on high.
- Turn the fireplace off and allow it to completely cool.
- Remove fixed glass assembly. See Section 15.D.
- Clean fixed glass assembly. See Section 3.
- Replace the fixed glass assembly and run continuously on high an additional 12 hours.

This cures the materials used to manufacture the fireplace.

NOTICE! Open windows for air circulation during fireplace break-in.

- Some people may be sensitive to smoke and odors.
- Smoke detectors may activate.

M. Frequently Asked Questions

ISSUE	SOLUTIONS
Condensation on the glass	This is a result of gas combustion and temperature variations. As the appliance warms, this condensation will disappear.
Blue flames	This is a result of normal operation and the flames will begin to yellow as the appliance is allowed to burn for 20 to 40 minutes.
Odor from appliance	When first operated, this appliance may release an odor for the first several hours. This is caused by the curing of materials from manufacturing. Odor may also be released from finishing materials and adhesives used near the appliance. These circumstances may require additional curing related to the installation environment.
Film on the glass	This is a normal result of the curing process of the paint and logs. Glass should be cleaned within 3 to 4 hours of initial burning. A non-abrasive cleaner such as gas appliance glass cleaner may be necessary. See your dealer.
Metallic noise	Noise is caused by metal expanding and contracting as it heats up and cools down, similar to the sound produced by a furnace or heating duct. This noise does not affect the operation or longevity of the appliance.
Is it normal to see the pilot flame burn continually?	In an IntelliFire™ Plus ignition system (IPI), the pilot flame should turn off when appliance is turned off. Some optional control systems available with IPI models may allow pilot flame to remain lit. In a standing pilot system the pilot will always stay on.

3 Maintenance and Service

Any safety screen or guard removed for servicing must be replaced prior to operating the fireplace.

When properly maintained, your fireplace will give you many years of trouble-free service. We recommend annual service by a qualified service technician.

A. Maintenance Tasks-Homeowner

Installation and repair should be done by a qualified service technician only. The fireplace should be inspected before use and at least annually by a professional service person.

The following tasks may be performed annually by the homeowner. If you are uncomfortable performing any of the listed tasks, please call your dealer for a service appointment.

More frequent cleaning may be required due to lint from carpeting or other factors. Control compartment, burner and circulating air passageway of the fireplace must be kept clean.

CAUTION! Risk of Burns! The fireplace should be turned off and cooled before servicing.

Glass Cleaning

Frequency: Seasonally

By: Homeowner

Tools Needed: Protective gloves, glass cleaner, drop cloth and a stable work surface.

CAUTION! Handle fixed glass assembly with care.
Glass is breakable.

- Avoid striking, scratching or slamming glass
- Avoid abrasive cleaners
- DO NOT clean glass while it is hot
- Prepare a work area large enough to accommodate fixed glass assembly and door frame by placing a drop cloth on a flat, stable surface.

Note: Fixed glass assembly and gasketing may have residue that can stain carpeting or floor surfaces.

- Remove door or decorative front from fireplace and set aside on work surface.
- See Section 15.D. for instructions to remove fixed glass assembly.
- Clean glass with a non-abrasive commercially available cleaner.
 - Light deposits: Use a soft cloth with soap and water
 - Heavy deposits: Use commercial fireplace glass cleaner (consult with your dealer)
- Carefully set fixed glass assembly in place on fireplace. Hold glass in place with one hand and secure glass latches with the other hand.
- Reinstall door or decorative front.

Doors, Surrounds, Fronts

Frequency: Annually

By: Homeowner

Tools needed: Protective gloves, stable work surface

- Assess condition of screen and replace as necessary.
- Inspect for scratches, dents or other damage and repair as necessary.
- Check that louvers are not blocked.
- Vacuum and dust surfaces.

Remote Control

Frequency: Seasonally

By: Homeowner

Tools needed: Replacement batteries and remote control instructions.

- Locate remote control transmitter and receiver.
- Verify operation of remote. Refer to remote control operation instructions for proper calibration and setup procedure.
- Place batteries as needed in remote transmitters and battery-powered receivers.
- Place remote control out of reach of children.

If not using your fireplace for an extended period of time (summer months, vacations/trips, etc), to prevent unintended operation:

- Remove batteries from remote controls.
- Unplug 6-volt power supply on IPI models.

Venting

Frequency: Seasonally

By: Homeowner

Tools needed: Protective gloves and safety glasses.

- Inspect venting and termination cap for blockage or obstruction such plants, bird nests, leaves, snow, debris, etc.
- Verify termination cap clearance to subsequent construction (building additions, decks, fences, or sheds). See Section 6.
- Inspect for corrosion or separation.
- Verify weather stripping, sealing and flashing remains intact.
- Inspect draft shield to verify it is not damaged or missing.

B. Maintenance Tasks-Qualified Service Technician

The following tasks must be performed by a qualified service technician.

Gasket Seal and Glass Assembly Inspection

Frequency: Annually

By: Qualified Service Technician

Tools needed: Protective gloves, drop cloth and a stable work surface.

- Inspect gasket seal and its condition.
- Inspect fixed glass assembly for scratches and nicks that can lead to breakage when exposed to heat.
- Confirm there is no damage to glass or glass frame. Replace as necessary.
- Verify that fixed glass assembly is properly retained and attachment components are intact and not damaged. Replace as necessary.

Firebox

Frequency: Annually

By: Qualified Service Technician

Tools needed: Protective gloves, sandpaper, steel wool, cloths, mineral spirits, primer and touch-up paint.

- Inspect for paint condition, warped surfaces, corrosion or perforation. Sand and repaint as necessary.
- Replace fireplace if firebox has been perforated.

Control Compartment and Firebox Top

Frequency: Annually

By: Qualified Service Technician

Tools needed: Protective gloves, vacuum cleaner, dust cloths

- Vacuum and wipe out dust, cobwebs, debris or pet hair. Use caution when cleaning these areas. Screw tips that have penetrated the sheet metal are sharp and should be avoided.
- Remove all foreign objects.
- Verify unobstructed air circulation.

Burner Ignition and Operation

Frequency: Annually

By: Qualified Service Technician

Tools needed: Protective gloves, vacuum cleaner, whisk broom, flashlight, voltmeter, indexed drill bit set, and a manometer.

- Verify burner is properly secured and aligned with pilot or igniter.
- Clean off burner top, inspect for plugged ports, corrosion or deterioration. Replace burner if necessary.
- Replace rockwool with new dime-size pieces. DO NOT block ports or obstruct lighting paths. Refer to Section 15 for proper rockwool placement.
- Verify batteries have been removed from battery back-up IPI systems to prevent premature battery failure or leaking.
- Check for smooth lighting and ignition carryover to all ports. Verify that there is no ignition delay.
- Inspect for lifting or other flame problems.
- Verify air shutter setting is correct. See Section 15 for required air shutter setting. Verify air shutter is clear of dust and debris.
- Inspect orifice for soot, dirt and corrosion. Verify orifice size is correct. See Service Parts List for proper orifice sizing.
- Verify manifold and inlet pressures. Adjust regulator as required.
- Inspect pilot flame pattern and strength. See Figure 3.1 for proper pilot flame pattern. Clean or replace orifice spud as necessary.
- Inspect thermocouple/thermopile or IPI flame sensing rod for soot, corrosion and deterioration. Polish with fine steel wool or replace as required.
- Verify thermocouple/thermopile or IPI millivolt output. Replace as necessary.

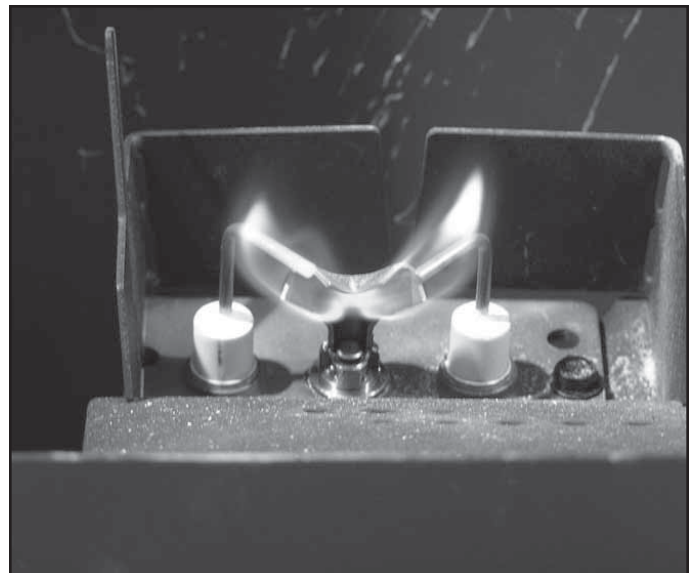

Figure 3.1 IPI Pilot Flame Patterns

4 Getting Started

Installer Guide

A. Typical Appliance System

NOTICE: Illustrations and photos reflect typical installations and are for design purposes only. Illustrations/diagrams are not drawn to scale. Actual product may vary from pictures in manual

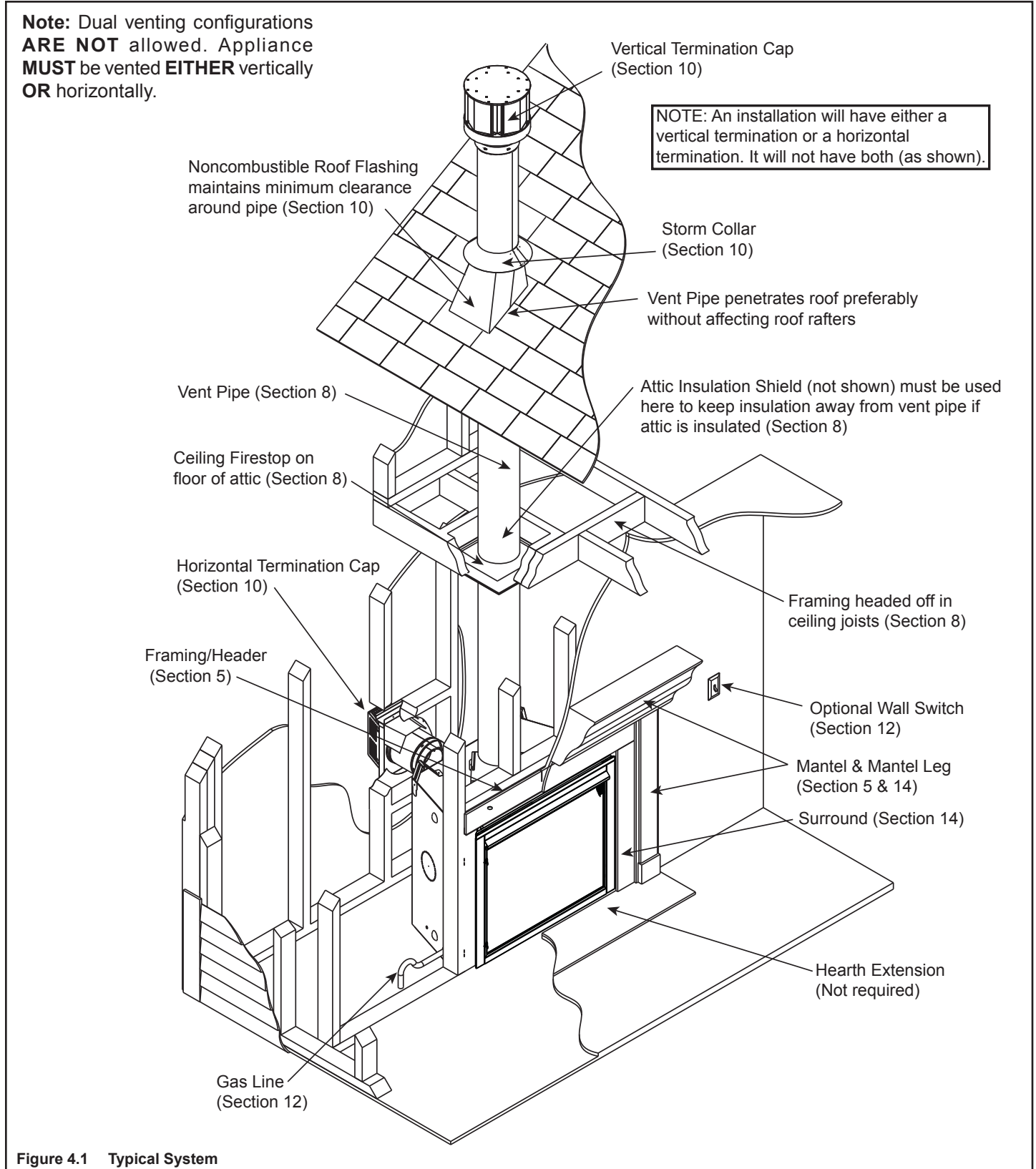

Figure 4.1 Typical System

B. Design and Installation Considerations

Heatilator direct vent gas appliances are designed to operate with all combustion air siphoned from outside of the building and all exhaust gases expelled to the outside. No additional outside air source is required.

Installation MUST comply with local, regional, state and national codes and regulations. Consult insurance carrier, local building inspector, fire officials or authorities having jurisdiction over restrictions, installation inspection and permits.

Before installing, determine the following:

- Where the appliance is to be installed.
- The vent system configuration to be used.
- Gas supply piping.
- Electrical wiring requirements.
- Framing and finishing details.
- Whether optional accessories—devices such as a fan, wall switch, or remote control—are desired.



Installation and service of this appliance should be performed by qualified personnel. Hearth & Home Technologies recommends HHT Factory Trained or NFI certified professionals.



Improper installation, adjustment, alteration, service or maintenance can cause injury or property damage. For assistance or additional information, consult a qualified service technician, service agency or your dealer.

C. Tools and Supplies Needed

Before beginning the installation be sure that the following tools and building supplies are available.

- | | |
|--------------|-----------------------------------|
| Tape measure | Framing material |
| Pliers | Non-corrosive leak check solution |
| Hammer | Phillips screwdriver |
| Gloves | Framing square |
| Voltmeter | Electric drill and bits (1/4 in.) |
| Plumb line | Safety glasses |
| Level | Reciprocating saw |
| Manometer | Flat blade screwdriver |
- 1/2 - 3/4 in. length, #6 or #8 Self-drilling screws
- Caulking material (300°F minimum continuous exposure rating)
- One 1/4 in. female connection (for optional fan).

D. Inspect Appliance and Components

- Carefully remove the appliance and components from the packaging.
- The vent system components and decorative doors and fronts may be shipped in separate packages.
- If packaged separately, the log set and appliance grate must be installed.
- Report to your dealer any parts damaged in shipment, particularly the condition of the glass.
- Read all of the instructions before starting the installation. Follow these instructions carefully during the installation to ensure maximum safety and benefit.

WARNING! Risk of Fire or Explosion! Damaged parts could impair safe operation. DO NOT install damaged, incomplete or substitute components. Keep appliance dry.

Hearth & Home Technologies disclaims any responsibility for, and the warranty will be voided by, the following actions:

- Installation and use of any damaged appliance or vent system component.
 - Modification of the appliance or vent system.
 - Installation other than as instructed by Hearth & Home Technologies.
 - Improper positioning of the gas logs or the glass door.
 - Installation and/or use of any component part not approved by Hearth & Home Technologies.

Any such action may cause a fire hazard.

WARNING! Risk of Fire, Explosion or Electric Shock! DO NOT use this appliance if any part has been under water. Call a qualified service technician to inspect the appliance and to replace any part of the control system and/or gas control which has been under water.

5 Framing and Clearances

A. Select Appliance Location

When selecting a location for the appliance it is important to consider the required clearances to walls (see Figure 5.1).

WARNING! Risk of Fire or Burns! Provide adequate clearance around air openings and for service access. Due to high temperatures, the appliance should be located out of traffic and away from furniture and draperies.

NOTICE: Illustrations reflect typical installations and are FOR DESIGN PURPOSES ONLY. Illustrations/diagrams are not drawn to scale. Actual installation may vary due to individual design preference.

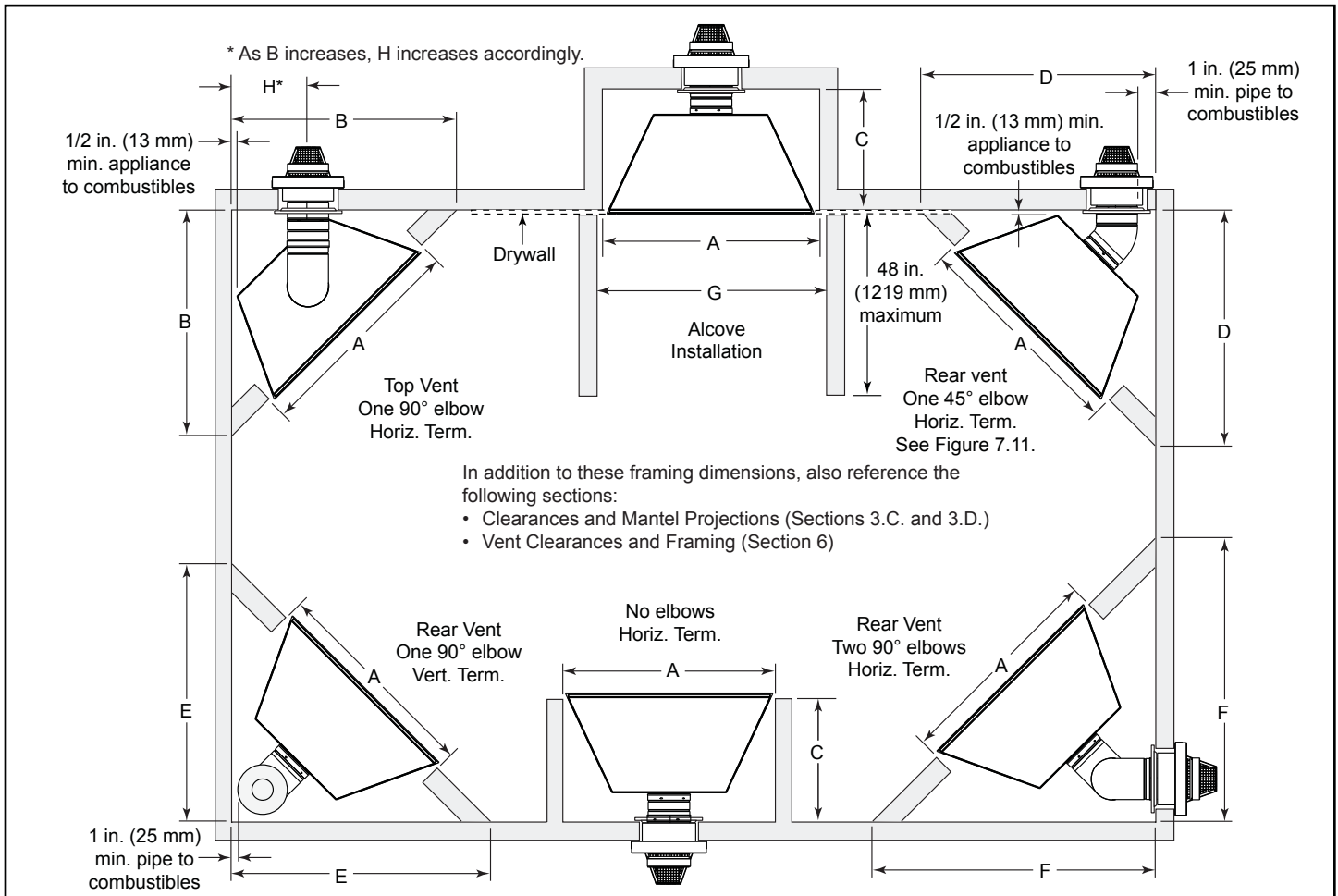

MODEL		A	B	C	D	E	F	G	H
NEVO3630	Inches	36	33-1/2	19-5/8	43-3/8	47	53-1/4	37	8-1/2
	Millimeters	914	851	498	1102	1194	1353	940	216
NEVO4236	Inches	42	37-5/8	19-5/8	43-3/8	47	53-1/4	43	10-5/8
	Millimeters	1067	956	498	1102	1194	1353	1092	270

Figure 5.1 Appliance Locations

B. Construct the Appliance Chase

A chase is a vertical box-like structure built to enclose the gas appliance and/or its vent system. In cooler climates the vent should be enclosed inside the chase.

NOTICE: *Treatment of ceiling firestops and wall shield firestops and construction of the chase may vary with the type of building. These instructions are not substitutes for the requirements of local building codes. Therefore, you MUST check local building codes to determine the requirements to these steps.*

Chases should be constructed in the manner of all outside walls of the home to prevent cold air drafting problems. The chase should not break the outside building envelope in any manner.

Walls, ceiling, base plate and cantilever floor of the chase should be insulated. Vapor and air infiltration barriers should be installed in the chase as per regional codes for the rest of the home. Additionally, in regions where cold air infiltration may be an issue, the inside surfaces may be sheetrocked and taped for maximum air tightness.

To further prevent drafts, the wall shield and ceiling firestops should be caulked with caulk with a minimum of 300°F continuous exposure rating to seal gaps. Gas line holes and other openings should be caulked with caulk with a minimum of 300°F continuous exposure rating or stuffed with unfaced insulation. If the appliance is being installed on a cement slab, a layer of plywood may be placed underneath to prevent conducting cold up into the room.

C. Clearances

NOTICE: Install appliance on hard metal or wood surfaces extending full width and depth. **DO NOT** install directly on carpeting, vinyl, tile or any combustible material other than wood.

WARNING! Risk of Fire! Maintain specified air space clearances to appliance and vent pipe:

- Insulation and other materials must be secured to prevent accidental contact.
- The chase must be properly blocked to prevent blown insulation or other combustibles from entering and making contact with fireplace or chimney.
- Failure to maintain airspace may cause overheating and a fire.

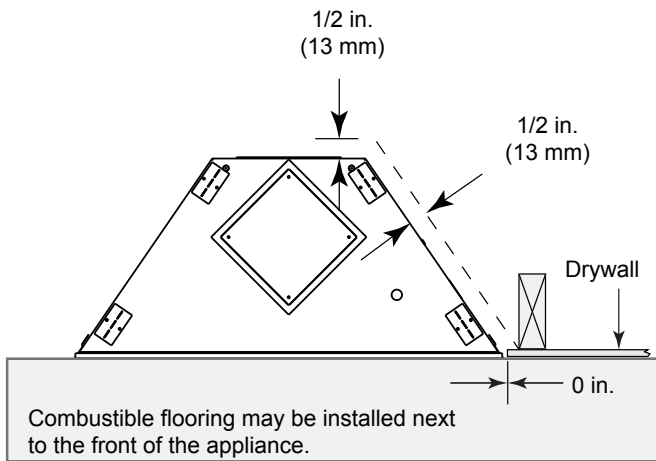

Note: If the inside of the framed cavity is to be finished, the framing dimensions **must** include the finished surface. If drywall is to be attached to the rear wall, the depth must be measured from the drywall surface.

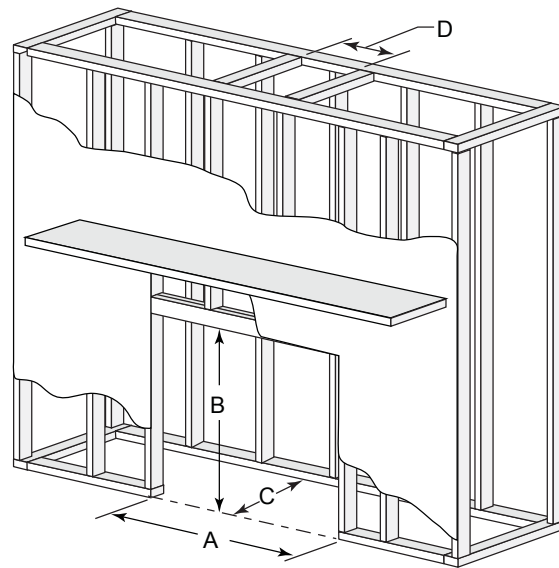
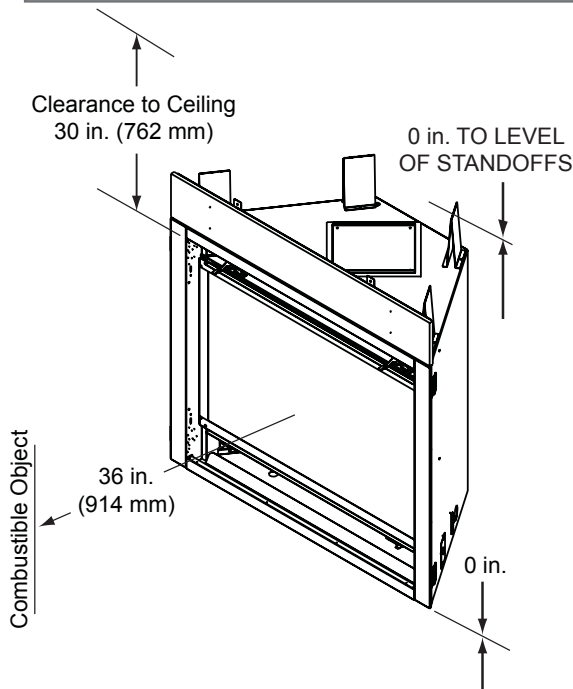

Model	A Rough Opening (Width)		B Rough Opening (Height)		C Rough Opening (Depth)		D Rough Opening (DVP Pipe)		D Rough Opening (SLP Pipe)	
	in.	mm	in.	mm	in.	mm	in.	mm	in.	mm
NEVO3630	36	914	39 7/8	1013	19 5/8	498	10	254	9	229
NEVO4236	42	1067	39 7/8	1013	19 5/8	498	10	254	9	229

If using the optional finishing trim, the unit must be installed on a platform at least 1 1/2 in. high. The **rough opening height** must be increased the same amount as the height of the platform.

Figure 5.2 Clearances to Combustibles

D. Mantel and Wall Projections

WARNING! Risk of Fire! Comply with all minimum clearances to combustibles as specified. Framing or finishing material closer than the minimums listed must be constructed entirely of non-combustible materials (i.e., steel studs, concrete board, etc).

Mantels

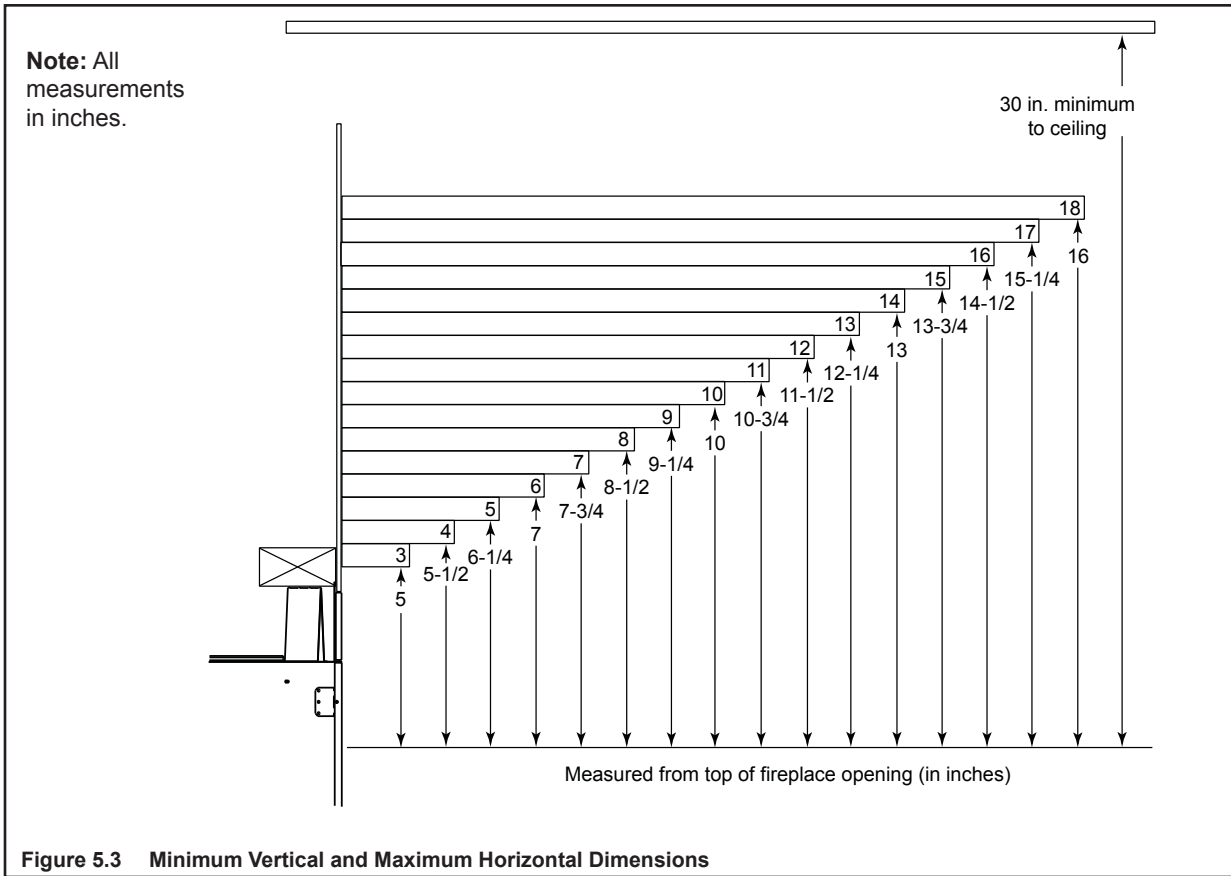

Mantel Legs or Wall Projections

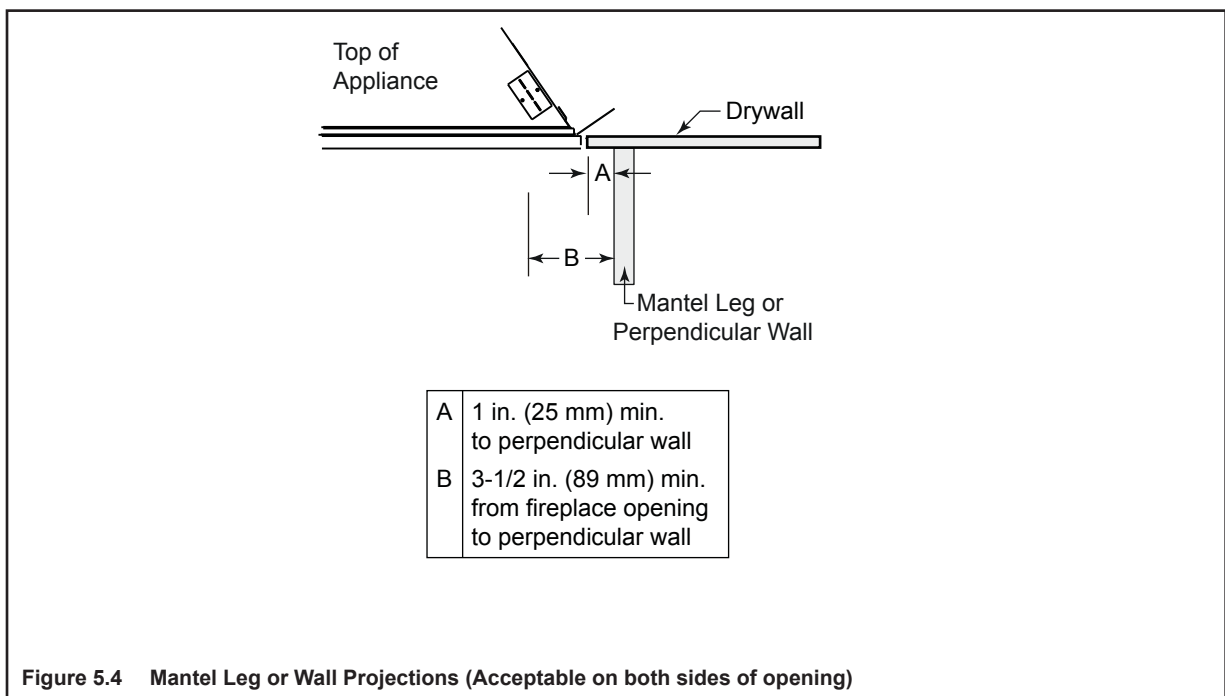

6 Termination Locations

A. Vent Termination Minimum Clearances

⚠ WARNING

Fire Risk.
Maintain vent clearance to combustibles as specified.

- DO NOT** pack air space with insulation or other materials.

Failure to keep insulation or other materials away from vent pipe may cause overheating and fire.

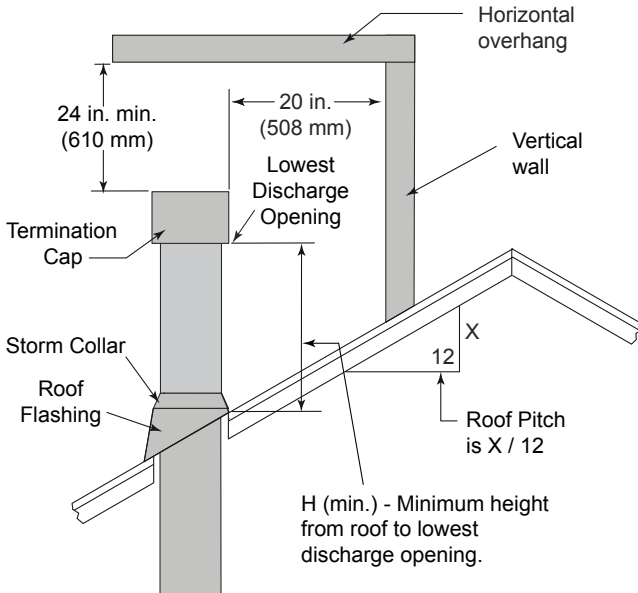

Roof Pitch	H (Min.) Ft.	Roof Pitch	H (Min.) Ft.
Flat to 6/12	1.0*	Over 11/12 to 12/12	4.0
Over 6/12 to 7/12	1.25*	Over 12/12 to 14/12	5.0
Over 7/12 to 8/12	1.5*	Over 14/12 to 16/12	6.0
Over 8/12 to 9/12	2.0*	Over 16/12 to 18/12	7.0
Over 9/12 to 10/12	2.5*	Over 18/12 to 20/12	7.5
Over 10/12 to 11/12	3.25	Over 20/12 to 21/12	8.0

* 3 ft. minimum in snow regions

Figure 6.1 Minimum Height From Roof To Lowest Discharge Opening

A	B
6 in. (minimum) up to 20 in. <i>152 mm/508 mm</i>	18 in. minimum <i>457 mm</i>
20 in. and over	0 in. minimum

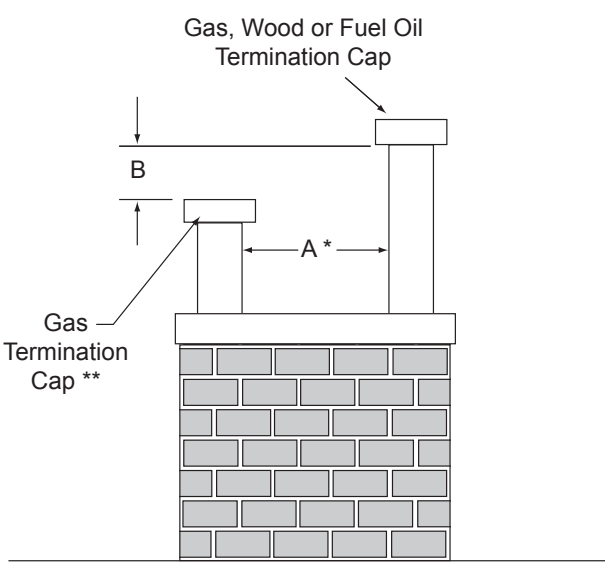

* If using decorative cap cover(s), this distance may need to be increased. Refer to the installation instructions supplied with the decorative cap cover.

** In a staggered installation with both gas and wood or fuel oil terminations, the wood or fuel oil termination cap must be higher than the gas termination cap.

Figure 6.2 Multiple Termination Caps

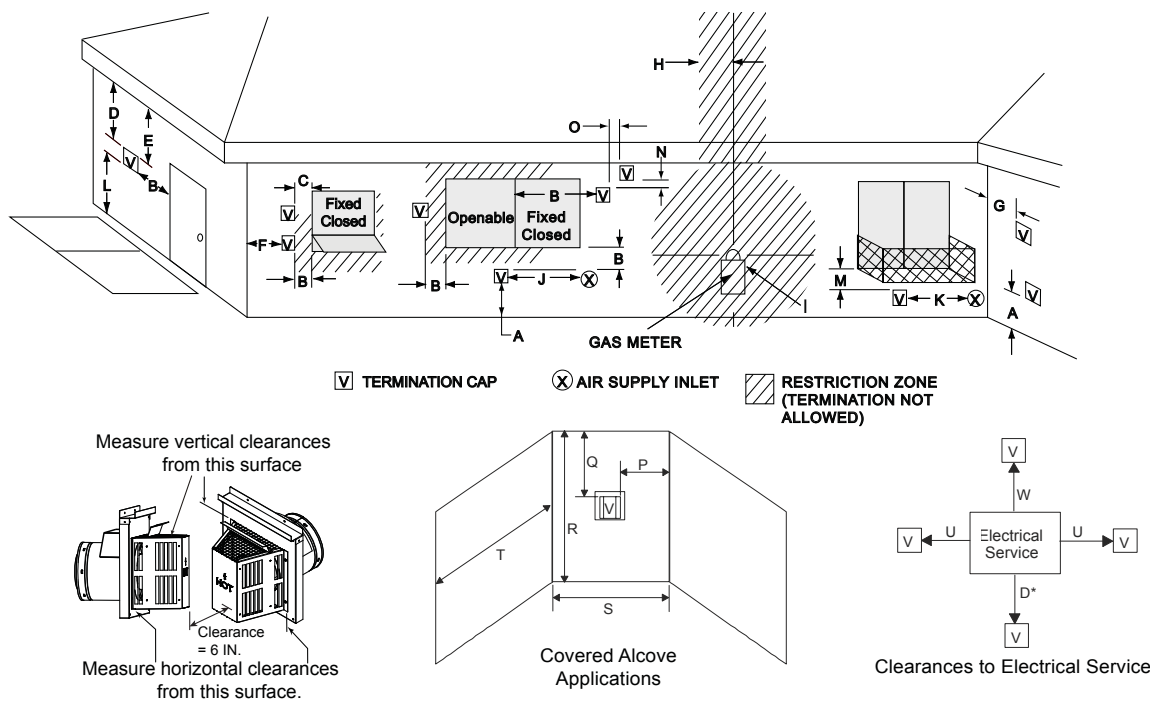

Dimension Descriptions

- A Clearance above the ground, a veranda, porch, deck or balcony - 12 in. (30 cm) minimum. *
- B Clearance to window or door that may be opened – 10,000 BTUs or less, 6 in. (15 cm) minimum; 10,000-50,000 BTUs, 9 in. (23 cm) minimum; over 50,000 BTUs, 12 in. (30 cm) minimum. *
- C Clearance to permanently closed window – 12 in. (30 cm) minimum - recommended to prevent condensation on window.
- D Vertical clearance to ventilated soffit located above the termination within a horizontal distance of 2 ft (60 cm) from the centerline of the termination – 18 in. (46 cm) minimum. **
- E Vertical clearance to unventilated soffit - 12 in. (30 cm) minimum. **
- F Clearance to outside corner - 6 in. (15 cm) minimum.
- G Clearance to inside corner - 6 in. (15 cm) minimum.
- H Not to be installed above a meter/regulator assembly within 3 ft (90 cm) horizontally* from the center line of the regulator (Canada only)
- I Clearance to service regulator vent outlet – 3 ft (.91 m) U.S. minimum and 3 ft (.91 m) Canada minimum. *
- J Clearance to non-mechanical air supply inlet into building or the combustion air inlet to any other appliance – 9" (23 cm) U.S. minimum and 12 in. (30 cm) Canada minimum. *
- K Clearance to mechanical air supply inlet - 3 ft (.91 m) U.S. minimum and 6 ft (1.8 m) Canada minimum. *
- L Clearance above a paved sidewalk or paved driveway located on public property - 7 ft (2.1 m) minimum.
A vent may not terminate directly above a sidewalk or paved driveway which is located between two single family dwellings and serves both dwellings.
- M Clearance under veranda, porch, deck or balcony - 12 in. (30 cm) minimum. * Recommended 30 in. (76 cm) for vinyl or plastic.
Only permitted if veranda, porch, deck or balcony is fully open on a minimum of 2 sides beneath the floor. *
- N Vertical clearance between two horizontal termination caps – 12 in. (30 cm) minimum.
- O Horizontal clearance between two horizontal termination caps – 12 in. (30 cm) minimum.

- P 6" - Non-vinyl sidewalls
12" – Vinyl sidewalls
- Q 18" – Non-vinyl soffit and overhang
42" – Vinyl soffit and overhang
- R 8 ft.

	S_{min}	T_{max}
1 cap	3 ft	2 x S actual
2 caps	6 ft	1 x S actual
3 caps	9 ft	2/3 x S actual
4 caps	12 ft	1/2 x S actual
S_{min} = # term caps x 3		T_{max} = (2/# term caps) x S (actual)

- U 6" min. – Clearance from sides of electrical service.
- W 12" min. – Clearance above electrical service.
- * As specified in CGA B149 Installation Codes
Note: Local codes or regulations may require different clearances.
- ** Clearance required to vinyl soffit material – 30 in. (76 cm) minimum.
Note: Location of the vent termination must not interfere with access to the electrical service.

WARNING!

In the U.S.: Vent system termination is NOT permitted in screened porches. You must follow side wall, overhang and ground clearances as stated in the instructions.

In Canada: Vent system termination is NOT permitted in screened porches. Vent system termination is permitted in porch areas with two or more sides open. You must follow all side wall, overhang and ground clearances as stated in the instructions.

Hearth & Home Technologies assumes no responsibility for the improper performance of the appliance when the venting system does not meet these requirements.

Figure 6.3 Minimum Clearances for Termination

CAUTION: IF EXTERIOR WALLS ARE FINISHED WITH VINYL SIDING, IT IS SUGGESTED THAT A VINYL PROTECTOR KIT BE INSTALLED.

7 Vent Information and Diagrams

A. Approved Pipe

This appliance is approved for use with Hearth & Home Technologies DVP and/or SLP venting systems. Refer to Section 17.B. for vent component information.

DO NOT mix pipe, fittings or joining methods from different manufacturers.

The pipe is tested to be run inside an enclosed wall. There is no requirement for inspection openings at each joint within the wall.

WARNING! Risk of Fire or Asphyxiation. This appliance requires a separate vent. **DO NOT** vent to a pipe serving a separate solid fuel burning appliance.

B. Vent Table Key

The abbreviations listed in this vent table key are used in the vent diagrams.

Symbol	Description
V ₁	First section (closest to appliance) of vertical length
V ₂	Second section of vertical length
H ₁	First section (closest to appliance) of horizontal length
H ₂	Subsequent sections of horizontal length

C. Use of Elbows

Diagonal runs have both vertical and horizontal vent aspects when calculating the effects. Use the rise for the vertical aspect and the run for the horizontal aspect (see Figure 7.1).

Two 45° elbows may be used in place of one 90° elbow. On 45° runs, one foot of diagonal is equal to 8-1/2 in. (216 mm) horizontal run and 8-1/2 in. (216 mm) vertical run. A length of straight pipe is allowed between two 45° elbows (see Figure 7.1).

D. Measuring Standards

Vertical and horizontal measurements listed in the vent diagrams were made using the following standards.

- Pipe measurements are shown using the effective length of pipe (see Figure 7.2).
- Horizontal terminations are measured to the outside mounting surface (flange of termination cap) (see Figure 6.4.).
- Vertical terminations are measured to bottom of termination cap.
- Horizontal pipe installed level with no rise.

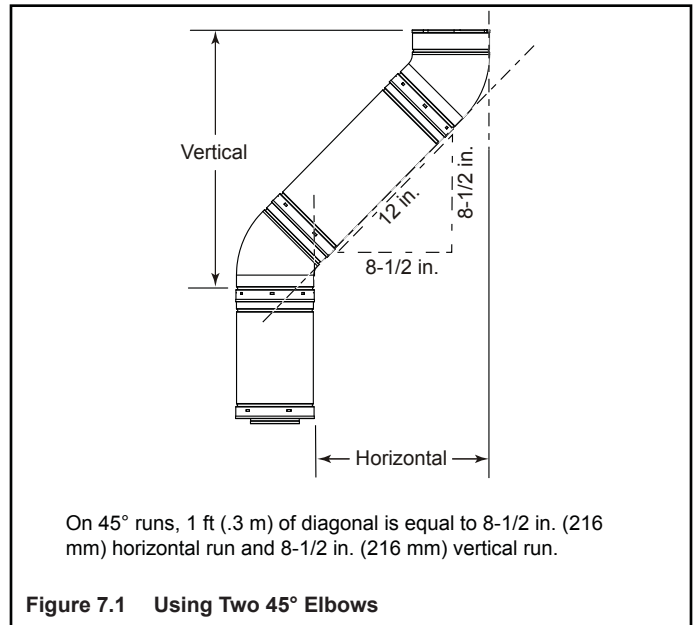

Figure 7.1 Using Two 45° Elbows

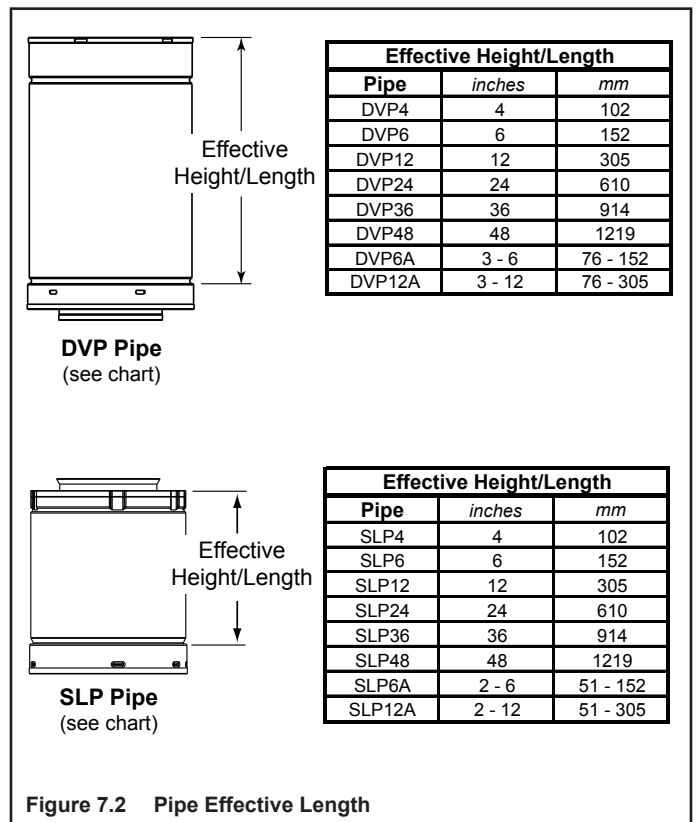

Figure 7.2 Pipe Effective Length

E. Vent Diagrams

To replace the first starter elbow with two 45° elbows, refer to Figure 7.4. All other 90° elbows can be replaced with two 45° elbows.

General Rules:

- SUBTRACT 3 ft. from the total H measurement for each 90° elbow installed horizontally.
- SUBTRACT 1-1/2 ft. from the total H measurement for each 45° elbow installed horizontally.
- A maximum of three 90° elbows (or six 45° elbows) may be used in any vent configuration. Some elbows may be installed horizontally. See Figure 7.8.
- Elbows may be placed back to back anywhere in the system as long as the first 90° elbow is a starter elbow except as shown in Figure 7.4.
- When penetrating a combustible wall, a wall shield firestop must be installed.
- When penetrating a combustible ceiling, a ceiling firestop must be installed.
- Horizontal runs of vent do not require vertical rise; horizontal runs may be level.
- Horizontal termination cap should have a 1/4 inch downward slant to allow any moisture in cap to be released.

1. Top Vent - Horizontal Termination

One Elbow

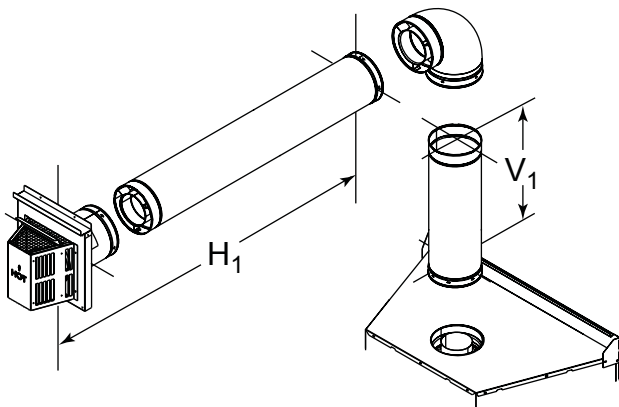

V ₁ min.		V ₁ max.		H ₁ max.	
in.	mm	ft	mm	ft	mm
12	305	-	-	2	610
16	406	-	-	4	1219
18	457	-	-	6	1829
24	610	-	-	11	3353
30	762	-	-	18	5486
36	914	-	-	20	6096
DVP		25	7620	20	6096
SLP		23	7010	20	6096

You may install the elbow directly on top of the appliance (DVP only).

Figure 7.3

Note: The NEVO series appliances can adapt to SLP series vent pipe when venting off the top of the appliance. You must use a DVP-SLP24 adapter which can only be attached to the appliance starting collar.

When looking at horizontal termination diagrams, the adapter is not counted as part of the minimum vertical (V₁ min.) requirements.

Whether horizontal or vertical termination, the adapter is counted as part of the maximum vertical limitations.

All venting rules for the vent run must still be followed.

HORIZONTAL EXAMPLE

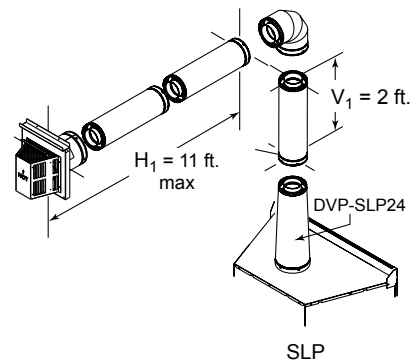
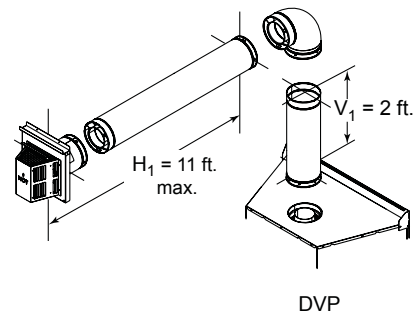

VERTICAL EXAMPLE

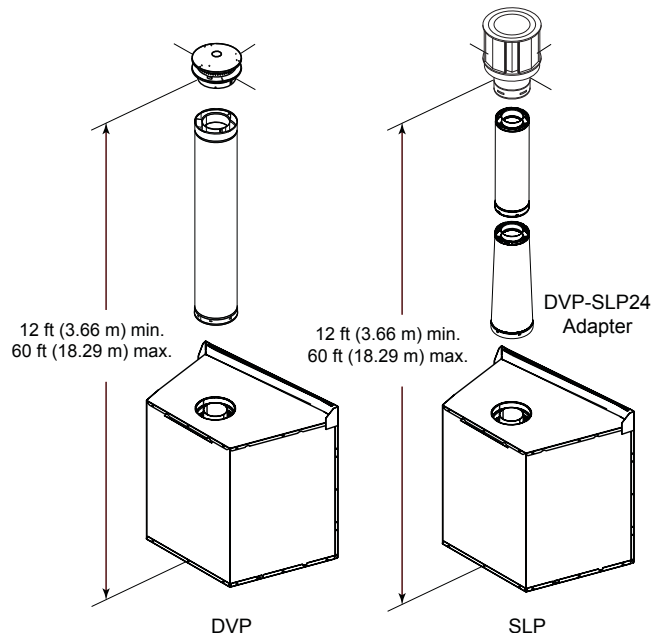

1. Top Vent - Horizontal Termination - (continued)

Two 45° Elbows replacing One 90° Elbow

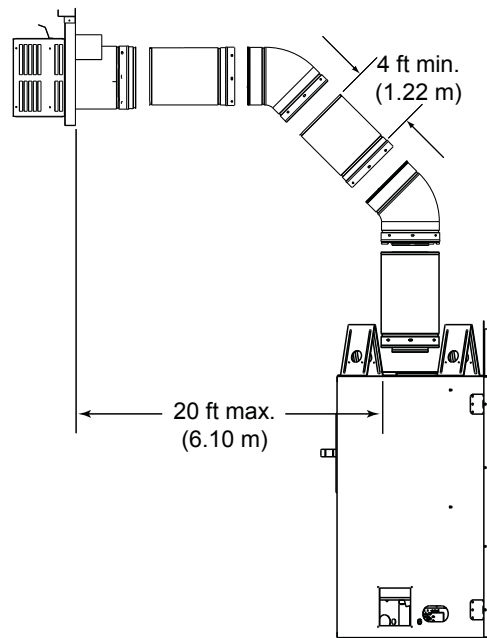

Figure 7.4

Two Elbows

V_1 min.		V_1 max.		H_1+H_2 max.		$H_1+H_2+H_3$ max.	
ft	m	ft	m	ft	m	ft	m
1.5	0.46	-	-	6	1.83	-	-
2	0.61	-	-	11	3.35	11	3.35
2.5	0.76	-	-	18	5.49	18	5.49
3	0.91	-	-	20	6.10	20	6.10
DVP		25	7.62	20	6.10	20	6.10
SLP		23	7.01	20	6.10	20	6.10

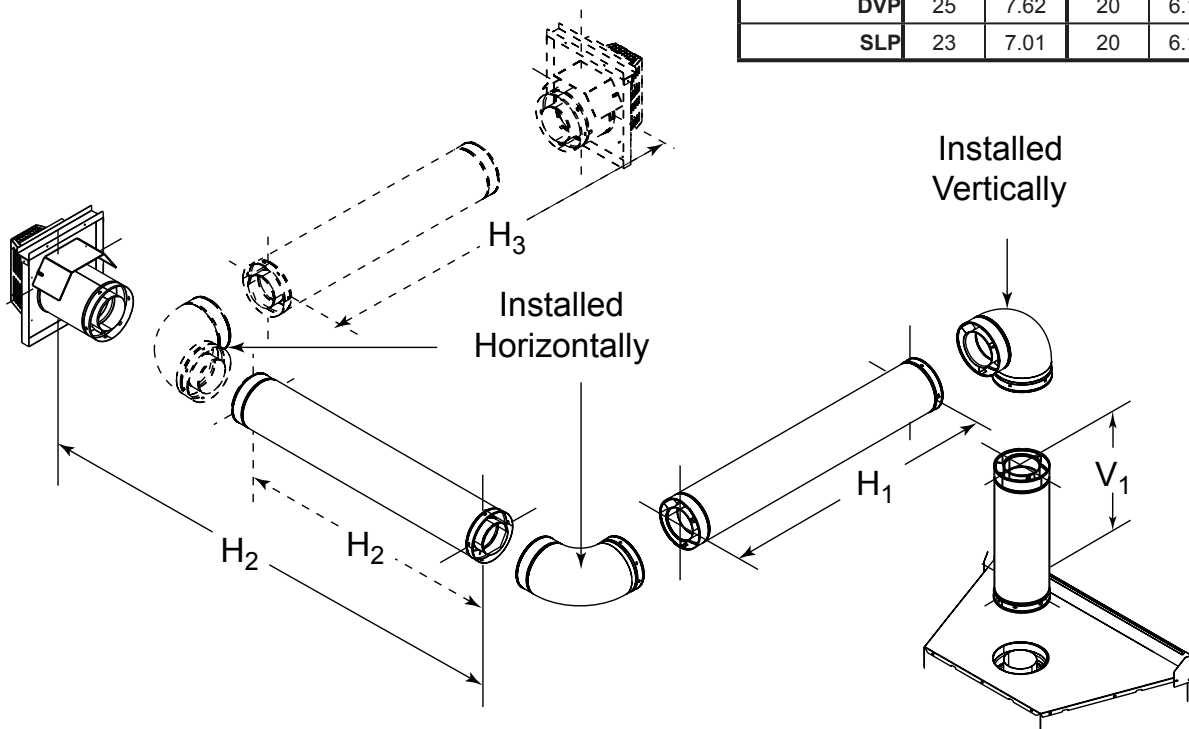

Figure 7.5

1. Top Vent - Horizontal Termination - (continued)

Three Elbows

	V ₁ min.		V ₁ + V ₂ max.		H ₁ +H ₂ max.	
	ft	m	ft	m	ft	m
DVP	2	0.61	24	7.32	19	5.79
SLP	2	0.61	22	6.71	19	5.79

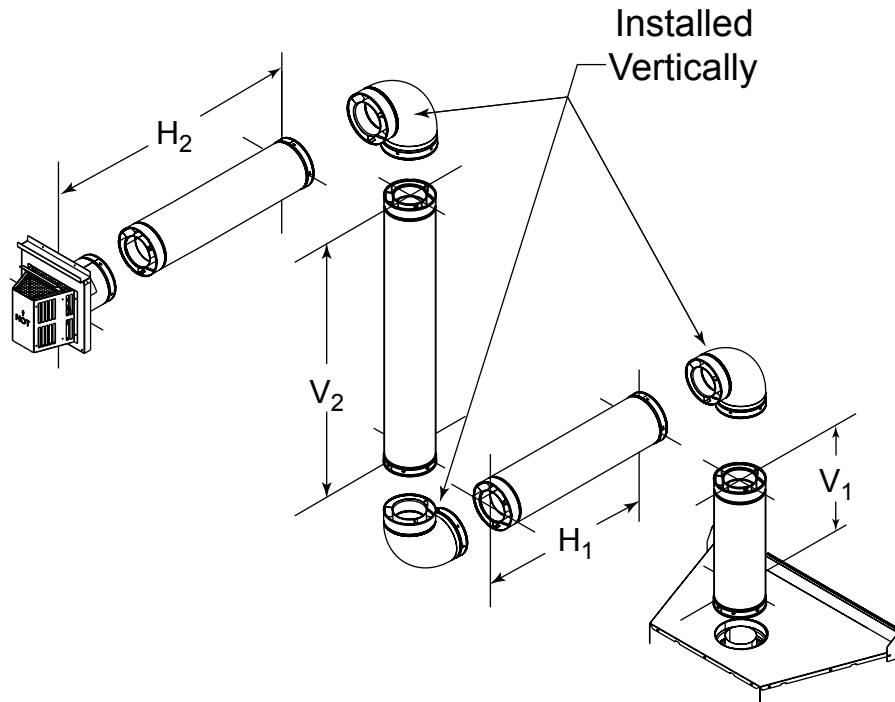

Figure 7.6

2. Top Vent - Vertical Termination

No Elbow

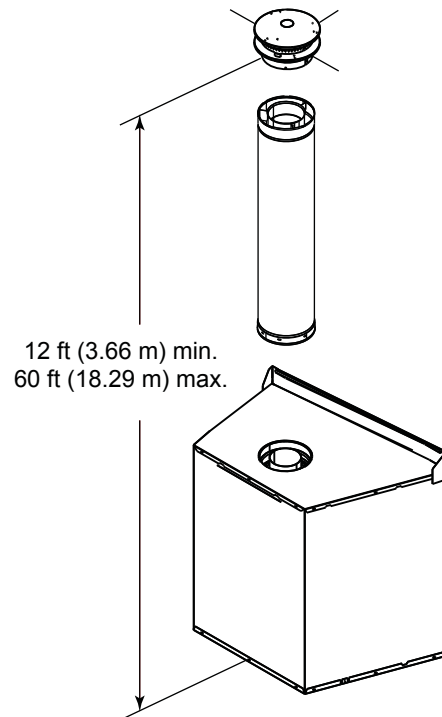

Figure 7.7

Install Top Vent Flue Baffle - No Elbow Configurations

- Remove screws holding flue visor to firebox top. See Figure 7.7a.
- Remove the flue visor.
- Using the screws removed and the same holes, install the top vent flue baffle and flue visor.
 - The flue baffle will be turned to install below the level of the firebox top for 12-30 ft vertical runs of vent. See Figure 7.7b.
 - The flue baffle will be turned to install inside the flue for vertical vent runs of 31-60 ft. See Figure 7.7c.

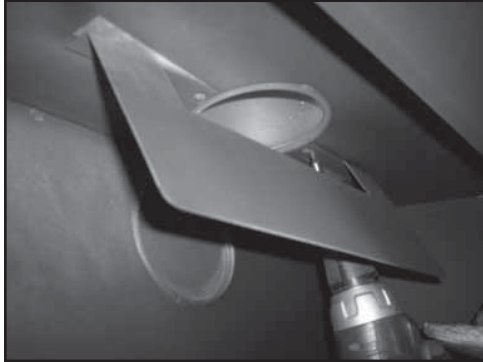

Figure 7.7a Remove Flue Visor



Figure 7.7b 12 to 30 ft Vertical Run



Figure 7.7c 31 ft to 60 ft Vertical Run

2. Top Vent - Vertical Termination - (continued)

Three Elbows

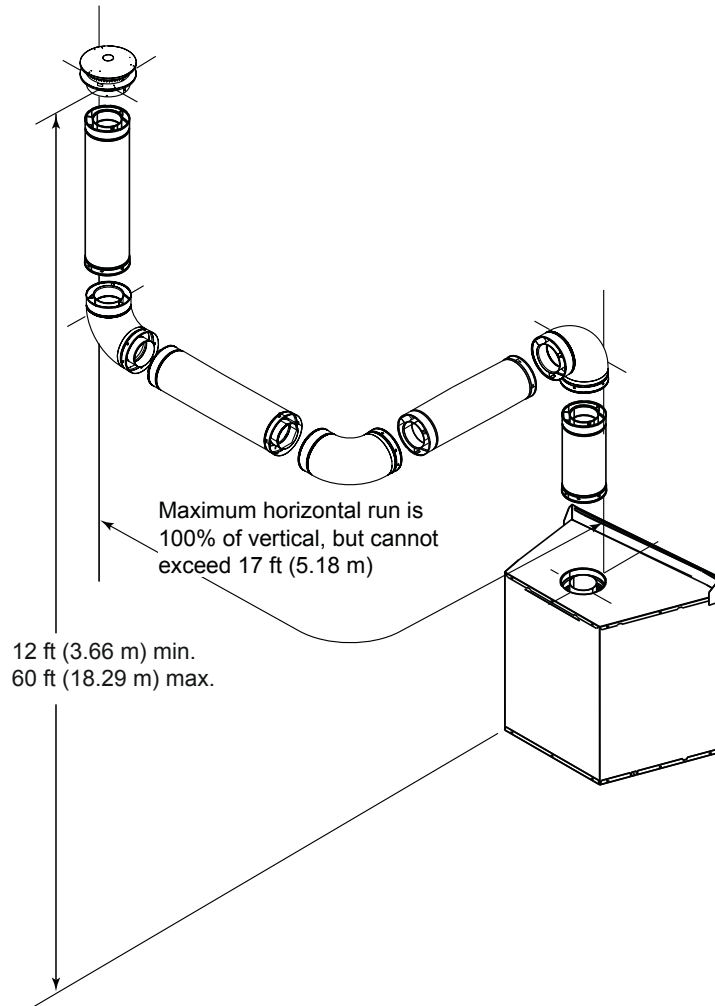

Figure 7.8

2. Top Vent - Vertical Termination - (continued)

Two Elbows

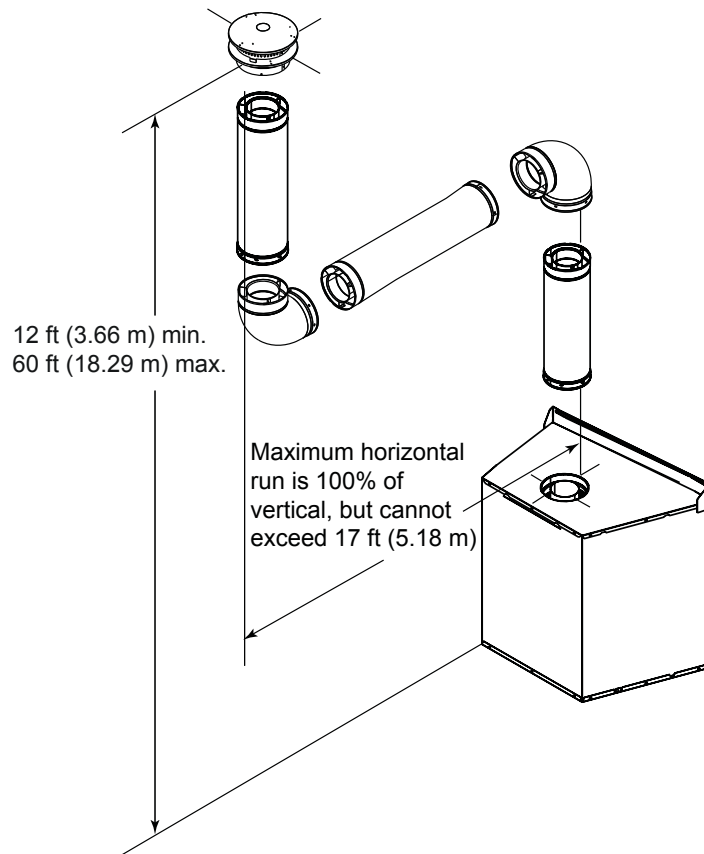

Figure 7.9

3. Rear Vent - Horizontal Termination

No Elbow

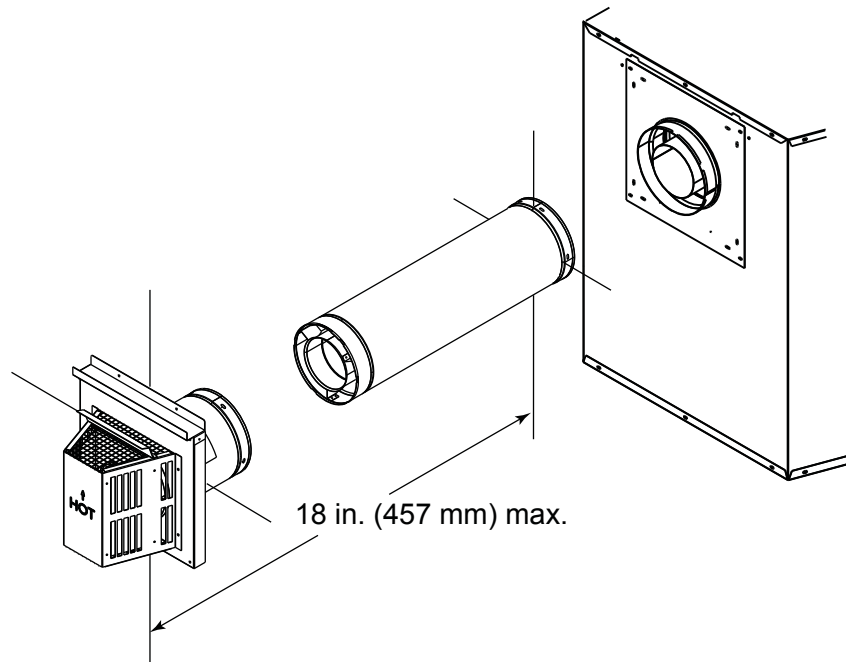
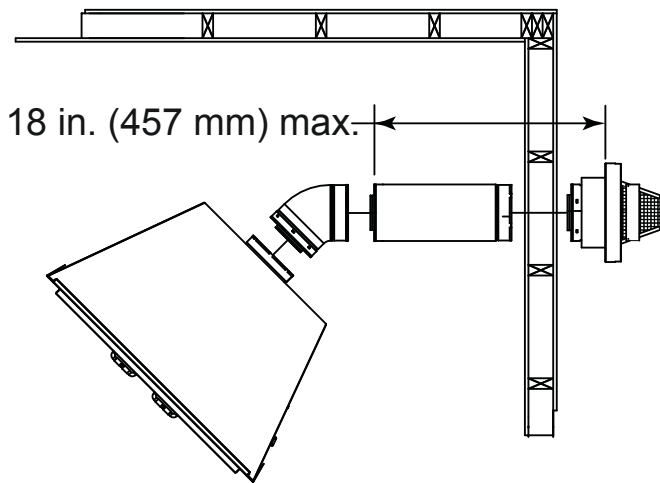

Figure 7.10

One 45° Elbow



NOTICE: To ensure proper operation of appliance, remove the pilot shield when the venting configuration includes a single 45° elbow and horizontal termination.

Remove pilot shield by removing the two screws and lifting the pilot shield out of the appliance as shown.

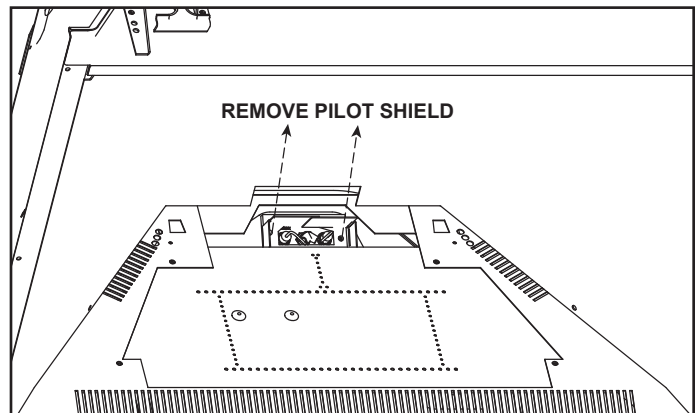

Figure 7.11

3. Rear Vent - Horizontal Termination - (continued)

Two Elbows

H ₁ max.		V ₁ min.		H ₁ +H ₂ max.	
<i>ft</i>	<i>m</i>	<i>ft</i>	<i>m</i>	<i>ft</i>	<i>m</i>
0	0	1	0.30	3	0.91
2	0.61	1	0.30	3	0.91
4	1.22	2	0.61	6	1.83
6	1.83	3	0.91	9	2.74
8	2.44	4	1.22	12	3.66
8	2.44	5	1.52	15	4.57
8	2.44	6	1.83	18	5.49

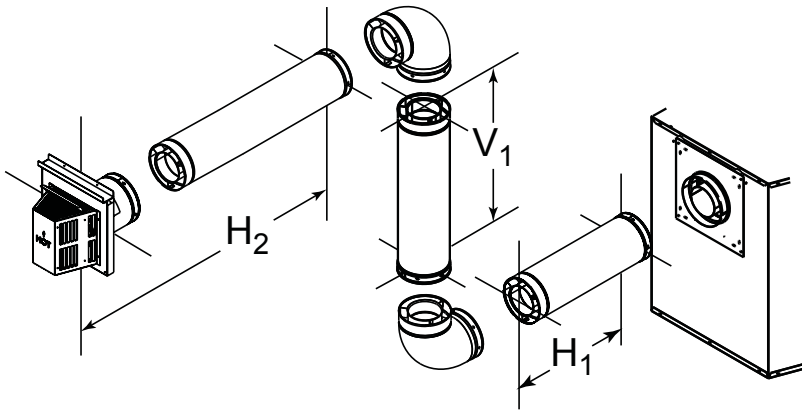

Figure 7.12

Three Elbows

H ₁ max.		V ₁ min.		H ₁ +H ₂ +H ₃ max.	
<i>ft</i>	<i>m</i>	<i>ft</i>	<i>m</i>	<i>ft</i>	<i>m</i>
0	0	1	0.30	3	0.91
2	0.61	1	0.30	3	0.91
4	1.22	2	0.61	6	1.83
6	1.83	3	0.91	9	2.74
8	2.44	4	1.22	12	3.66
8	2.44	5	1.52	15	4.57
8	2.44	6	1.83	18	5.49

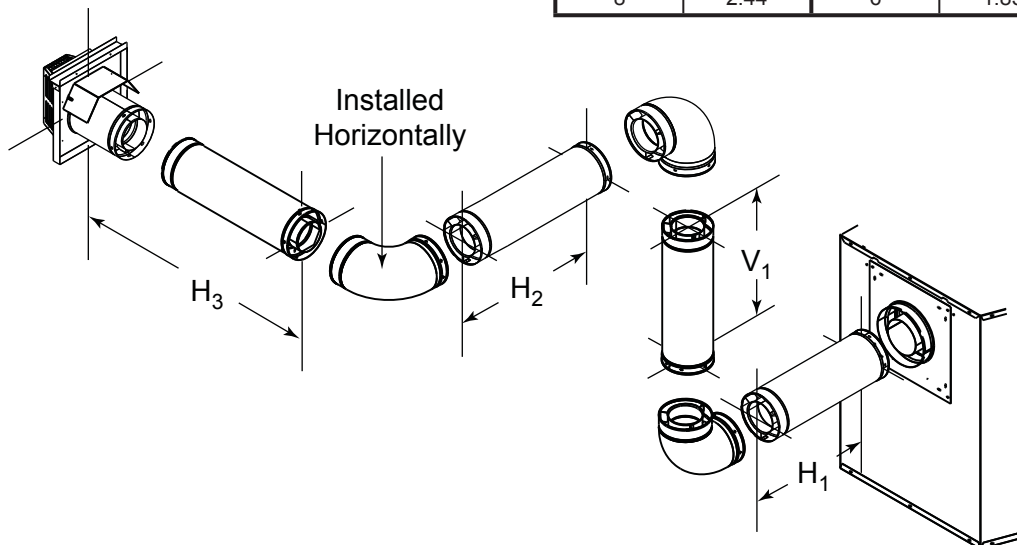

Figure 7.13

4. Rear Vent - Vertical Termination

One Elbow

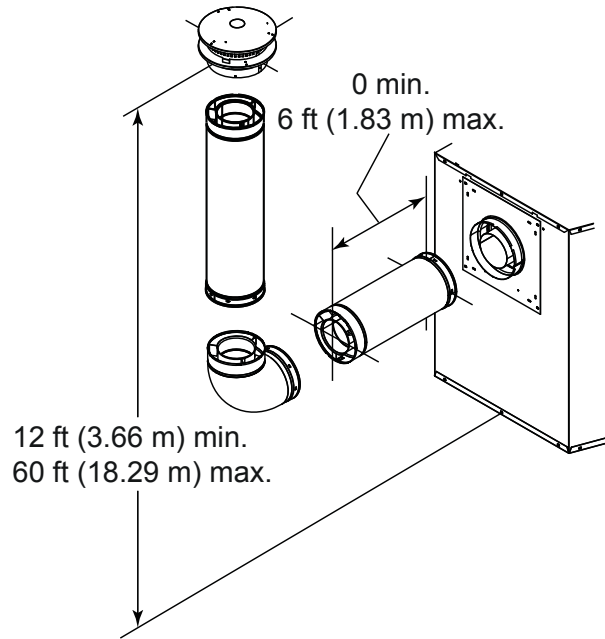

Figure 7.14

Two Elbows

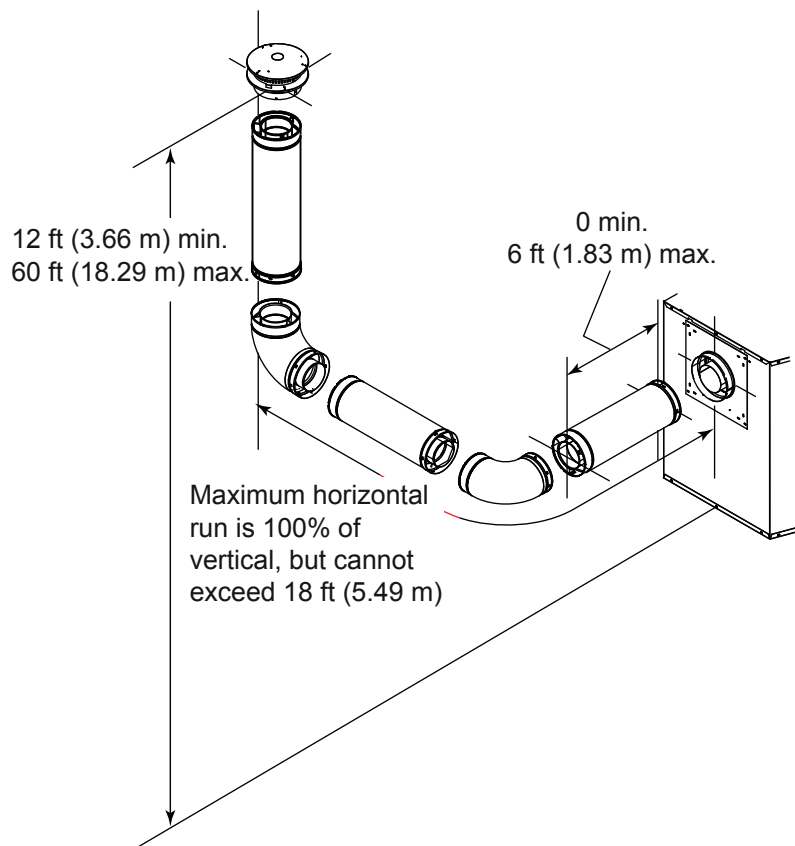

Figure 7.15

4. Rear Vent - Vertical Termination - (continued)

Three Elbows

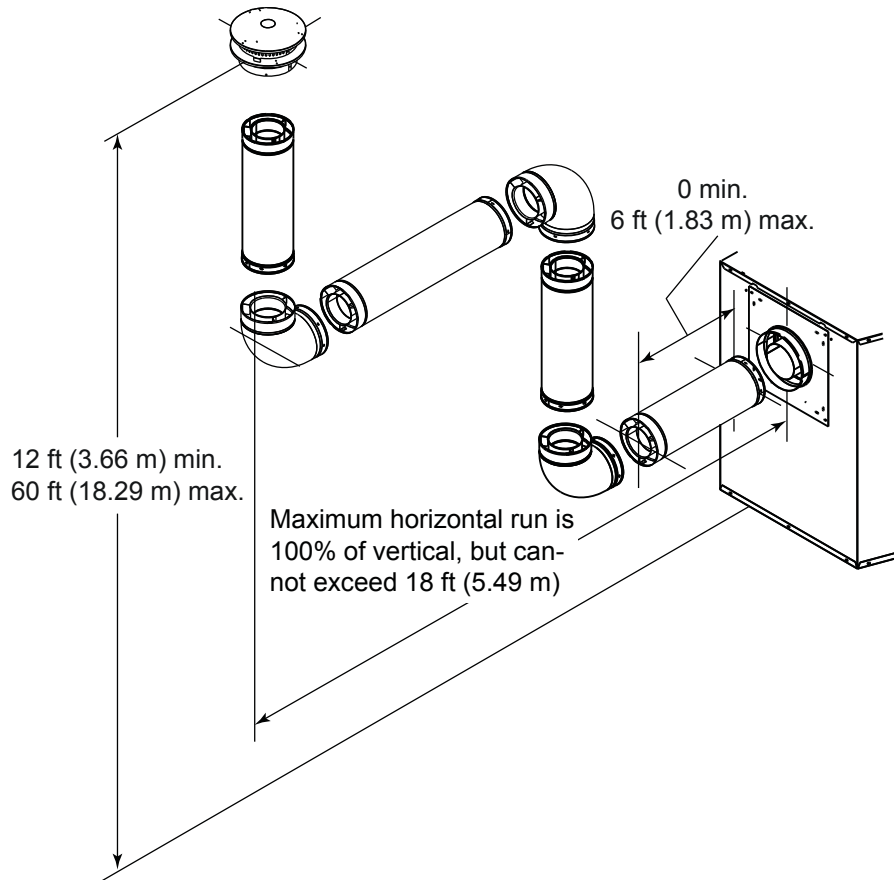

Figure 7.16

8 Vent Clearances and Framing

A. Pipe Clearances to Combustibles

WARNING! Risk of Fire! Maintain air space clearance to vent. DO NOT pack insulation or other combustibles:

- Between ceiling firestops
- Between wall shield firestops
- Around vent system

Failure to keep insulation or other material away from vent pipe may cause over heating and fire.

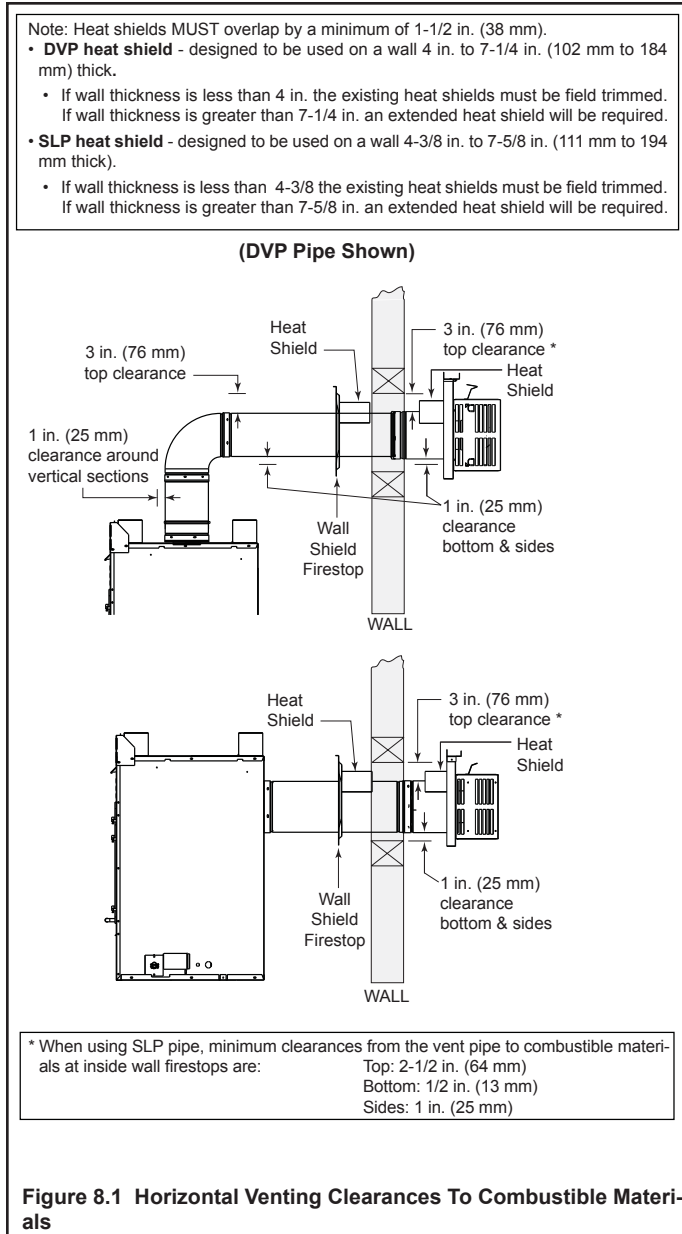

B. Wall Penetration Framing

Combustible Wall Penetration

Whenever a combustible wall is penetrated, you must frame a hole for the wall shield firestop(s). The wall shield firestop maintains minimum clearances and prevents cold air infiltration.

- The opening must be framed on all four sides using the same size framing materials as those used in the wall construction.
- SLP pipe - A wall shield firestop must be placed on each side of an interior wall. A minimum 1 1/2 in. (38 mm) overlap of attached heat shields must be maintained.
- DVP pipe - A wall shield firestop is required on one side only on interior walls. If your local inspector requires a wall shield firestop on both sides, then both wall shield firestops must have a heat shield attached to them.
- See Section 10.L. for information for regarding the installation of a horizontal termination cap.

Non-Combustible Wall Penetration

If the hole being penetrated is surrounded by non-combustible materials such as concrete, a hole with diameter one inch greater than the pipe is acceptable.

Whenever a non-combustible wall is penetrated, the wall shield firestop is only required on one side and no heat shield is necessary.

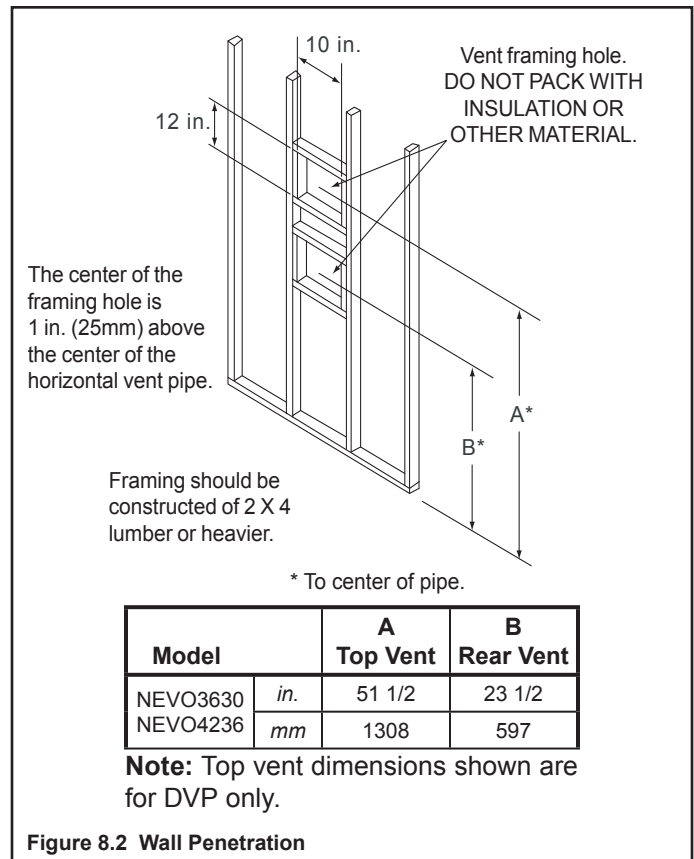

C. Install the Ceiling Firestop

A ceiling firestop **MUST** be used between floors and attics.

- **DVP pipe only** - Frame an opening 10 in. by 10 in. (254 mm by 254 mm) whenever the vent penetrates a ceiling/floor (see Figure 8.3).
- **SLP pipe only** - Frame opening 9 in. x 9 in. (229 mm x 229 mm) whenever the vent penetrates a ceiling/floor (see Figure 8.3).
- Frame the area with the same sized lumber as used in ceiling/floor joist.
- The ceiling firestop may be installed above or below the ceiling joists when installed with a attic insulation shield. It must be under joists between floors that are not insulated. Refer to Figure 8.4.
- Secure with three fasteners on each side.

WARNING! Risk of Fire! DO NOT pack insulation around the vent. Insulation must be kept back from the pipe to prevent overheating.

D. Install Attic Insulation Shield

WARNING! Fire Risk. DO NOT allow loose materials or insulation to touch vent. Hearth & Home Technologies requires the use of an attic shield.

The International Fuel Gas Code requires an attic shield constructed of 26 gauge minimum steel that extends at least 2 in. (51 mm) above insulation.

- Attic insulation shields must meet specified clearances to combustible materials and be secured in place.
- An attic insulation shield kit is available from Hearth & Home Technologies. Contact your dealer to order. Install attic insulation shield according to instructions included with kit.

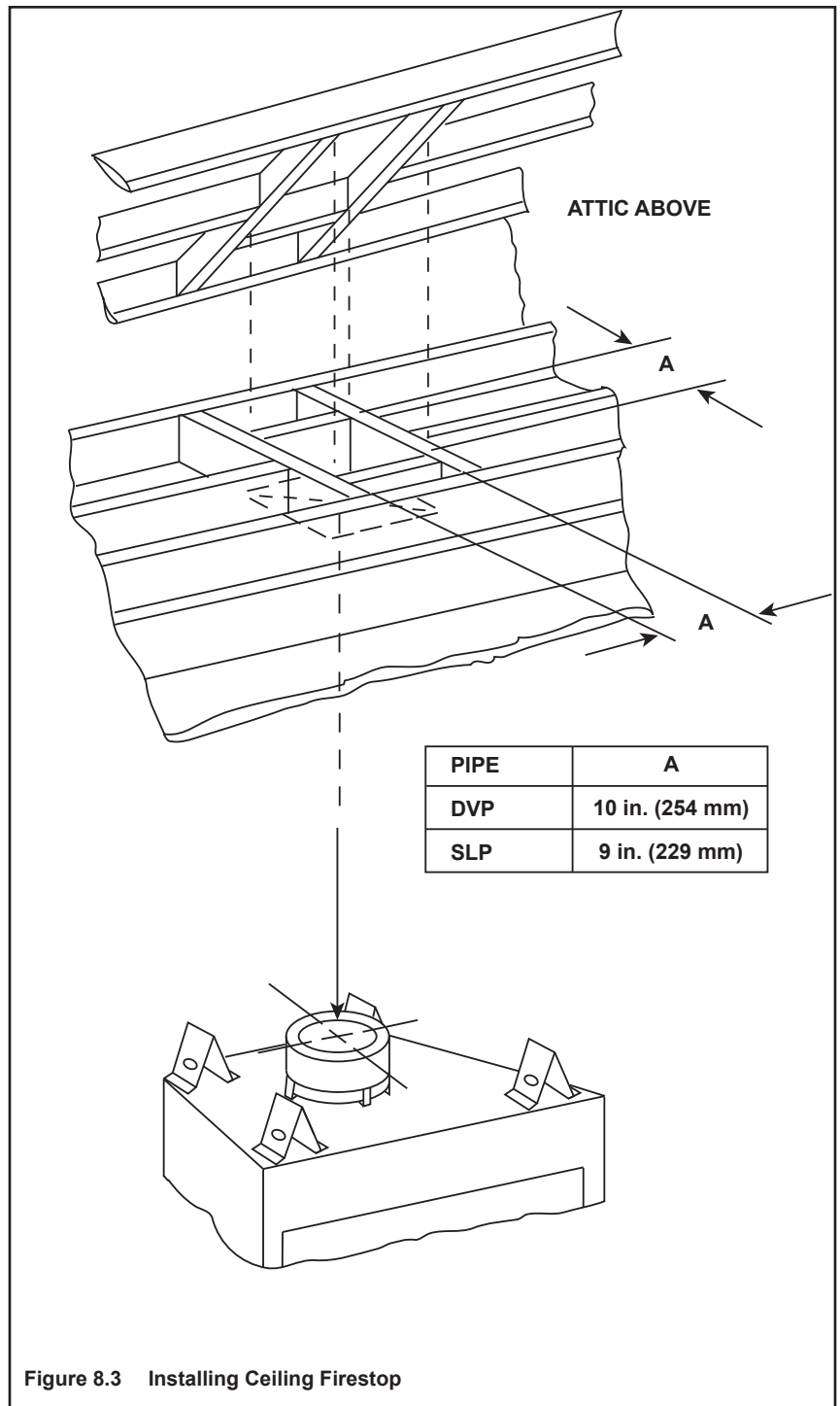

Figure 8.3 Installing Ceiling Firestop

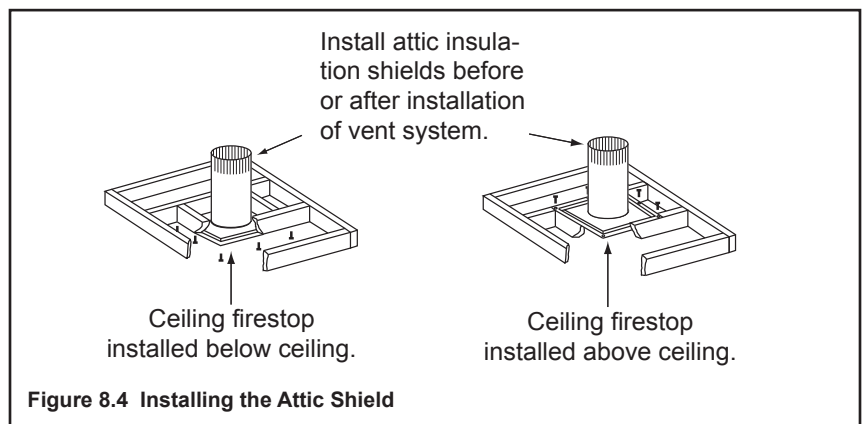

Figure 8.4 Installing the Attic Shield

9 Appliance Preparation

A. Top Vent

CAUTION! Risk of Cuts, Abrasions or Flying Debris.
Wear protective gloves and safety glasses during installation. Sheet metal edges are sharp.

NOTICE: Once appliance is set up for top or rear venting, it CANNOT be changed at a later time.

- Remove the cover plate by removing the four screws holding it to the top of the appliance. Remove and discard the cover plate.



Figure 9.1

- Remove the center insulation plug.



Figure 9.2

- Cut the metal retaining band and fold the sides out.



Figure 9.3

- Fold the center parts of the retaining band up and use to remove the vent cap.



Figure 9.4

- Discard the vent cap, remove and discard the insulation basket.

Note: Once the vent cap has been removed it cannot be reattached.



Figure 9.5

- Remove the insulation from the outer vent pipe. For rear venting there is no insulation in the outer vent pipe.

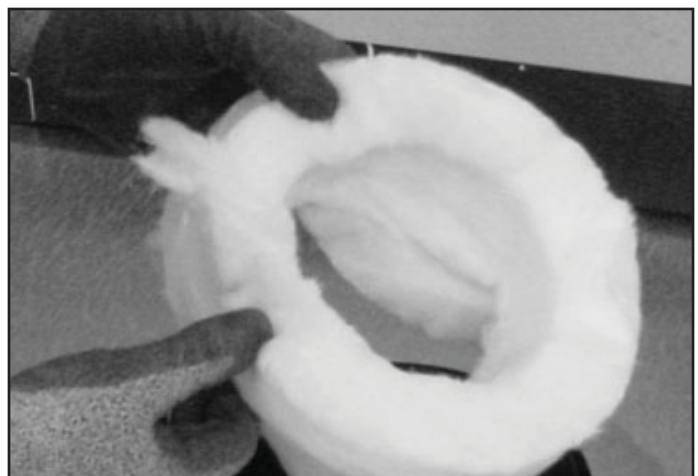

Figure 9.6

- Snap the first vent section into place.

B. Rear Vent

NOTICE: Once appliance is set up for top or rear venting, it **CANNOT** be changed at a later time.

- Fold the tabs toward the center of the vent cap (90°) and remove the insulation gasket.



Figure 9.7

- Cut the metal retaining band and fold the sides out.



Figure 9.8

- Fold the center parts of the retaining band out and use to remove the vent cap.



Figure 9.9

- Discard the vent cap, remove and discard the insulation basket.

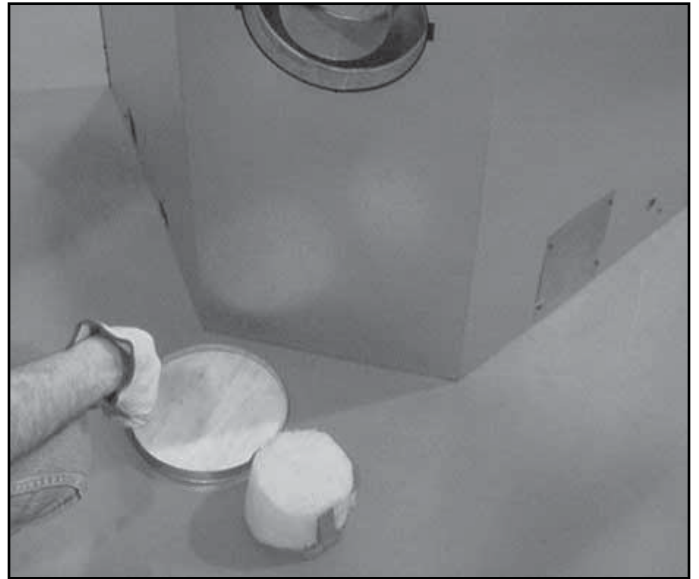

Figure 9.10

- Attach the first vent section (it will snap into place). Slide the insulation gasket onto the vent section, up against the appliance and over the tabs.

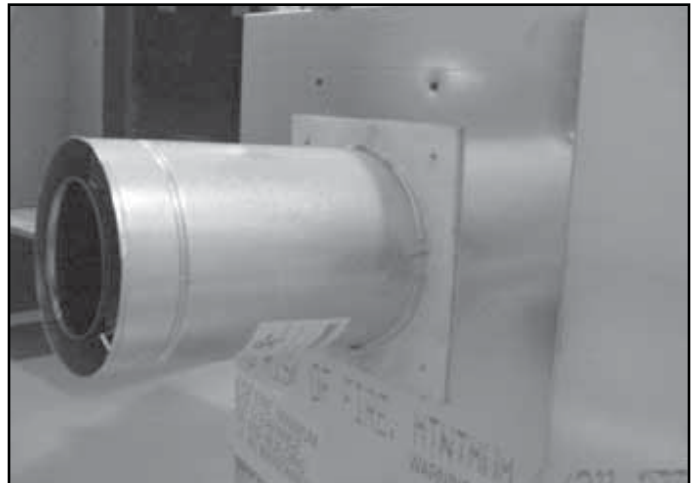

Figure 9.11

C. Secure and Level the Appliance

WARNING! Risk of Fire! Prevent contact with:

- Sagging or loose insulation
- Insulation backing or plastic
- Framing and other combustible materials

Block openings into the chase to prevent entry of blown-in insulation. Make sure insulation and other materials are secured.

DO NOT notch the framing around the appliance standoffs.

Failure to maintain air space clearance may cause overheating and fire.

The diagram shows how to properly position and secure the appliance (see Figure 9.12). Nailing tabs are provided to secure the appliance to the framing members.

- Bend out nailing tabs on each side.
- Place the appliance into position.
- Keep nailing tabs flush with the framing.
- Level the appliance from side to side and front to back.
- Shim the appliance as necessary. It is acceptable to use wood shims underneath the appliance.
- Secure the appliance to the framing by using nails or screws through the nailing tabs.
- Secure the appliance to the floor by inserting two screws through the pilot holes at the bottom of the appliance.

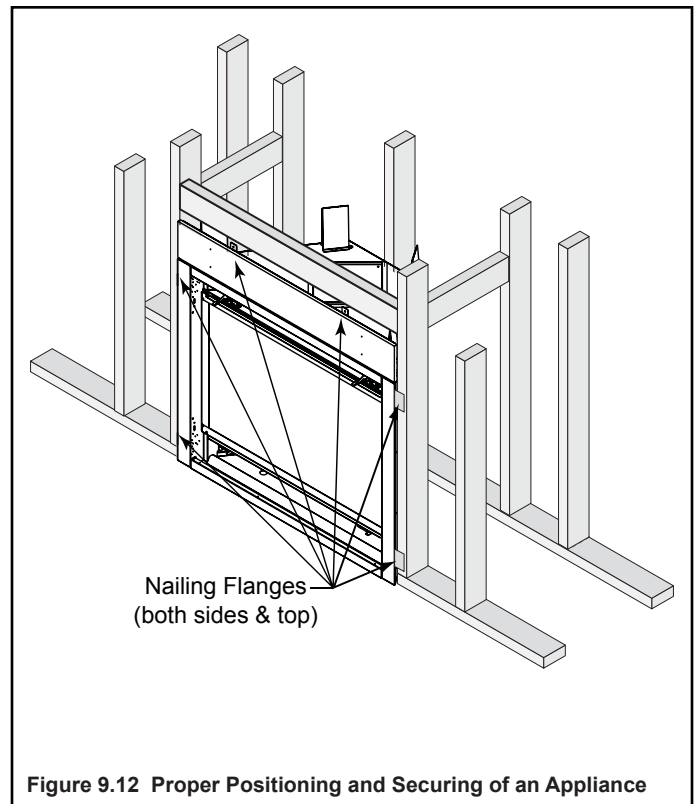

10 Install Vent Pipe

A. Assemble Vent Sections (DVP Only)

Attach Pipe to the Firebox Assembly

Note: The end of the pipe sections with the lanced tabs will face towards the appliance.

Attach the first pipe section to the starting collar:

- Lanced pipe end to the starting collar
- Inner pipe over inner collar
- Push the pipe section until all lanced tabs snap in place
- Lightly tug on pipe to confirm it has locked.

Commercial, Multi-family (Multi-level exceeding two stories), or High-Rise Applications

All outer pipe joints must be sealed with high temperature silicone, including the slip section that connects directly to the horizontal termination cap.

- Apply a bead of silicone sealant inside the female outer pipe joint prior to joining sections. See Figure 10.1
- Only outer pipes need to be sealed. All unit collar, pipe, slip section, elbow and cap outer flues shall be sealed in this manner, unless otherwise stated.

WARNING! Risk of Fire or Explosion! DO NOT break silicone seals on slip sections. Use care when removing termination cap from slip pipe. If slip section seals are broken during removal of the termination cap, vent may leak.

Assemble Pipe Sections

Per Figure 10.2:

- Start the inner pipe on the lanced end of section A into the flared end of section B.
- Start the outer pipe of section A over the outer pipe of section B.
- Once both vents sections are started, push firmly until all lanced tabs lock into place.
- Lightly tug on the pipe to confirm the tabs have locked.

It is acceptable to use screws no longer than 1/2 in. (13 mm) to hold outer pipe sections together. If predrilling holes, **DO NOT** penetrate inner pipe.

For 90° and 45° elbows that are changing the vent direction from horizontal to vertical, one screw minimum should be put in the outer flue at the horizontal elbow joint to prevent the elbow from rotating. Use screws no longer than 1/2 in. (13 mm). If predrilling screw holes, **DO NOT** penetrate inner pipe.

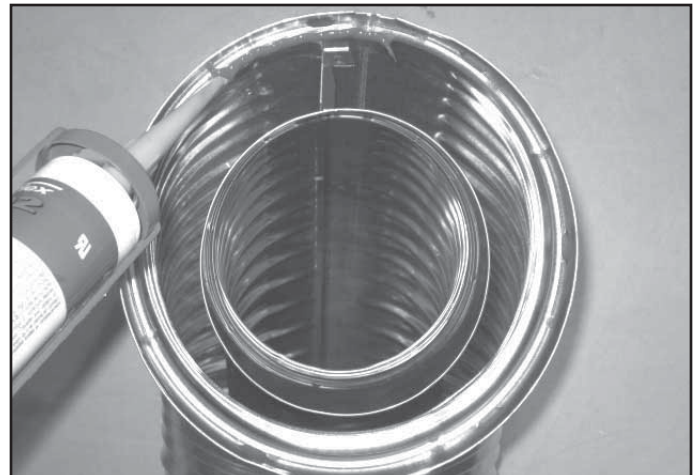

Figure 10.1 High Temperature Silicone Sealant

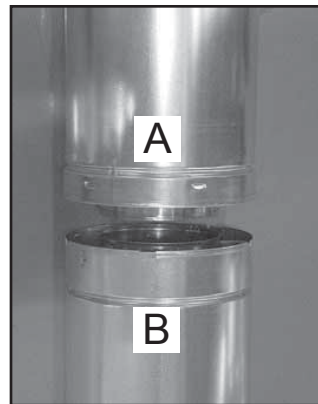

Figure 10.2

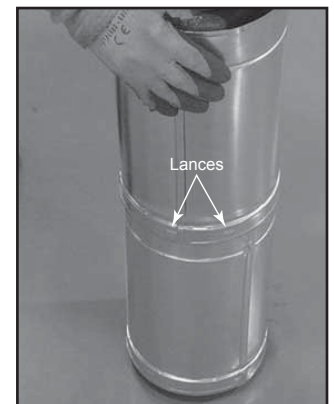

Figure 10.3

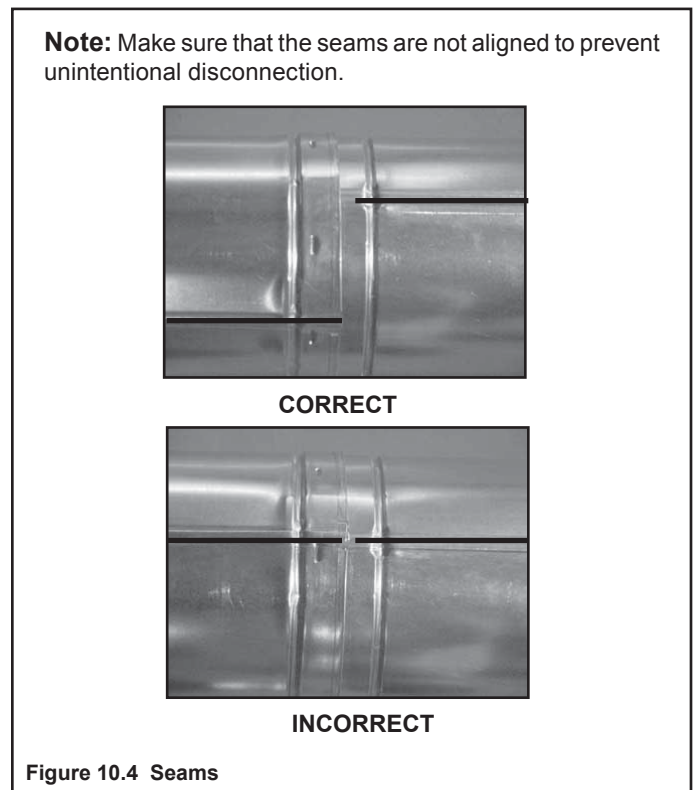

Figure 10.4 Seams

B. Assemble Vent Sections (SLP Only)

To attach the first vent component to the starting collars of the appliance

- Attach a DVP-SLP24 adapter to the starting collar of the appliance.
- Lock the vent components into place by sliding the pipe section onto the collar.
- Align the seam of the pipe and seam of collar to allow engagement. Rotate the vent component to lock into place. Use this procedure for all vent components. See Figure 10.5.
- Slide the gasket over the first vent section and place it flush to the appliance. This will prevent cold air infiltration. Caulk with a minimum of 300°F continuous exposure rating may be used to hold the part in place.
- Continue adding vent components, locking each succeeding component into place.
- Ensure that each succeeding vent component is securely fitted and locked into the preceding component.

Commercial, Multi-family (Multi-level exceeding two stories), or High-Rise Applications

For Installation into a commercial, multi-family (multi-level exceeding two stories) or high-rise applications: All outer pipe joints must be sealed with high temperature silicone, including the slip section that connects directly to the horizontal termination cap.

- Apply a bead of silicone sealant inside the female outer pipe joint prior to joining sections. See Figure 10.1
- Only outer pipes need to be sealed. All unit collar, pipe, slip section, elbow and cap outer flues shall be sealed in this manner, unless otherwise stated.

WARNING! Risk of Fire or Explosion! DO NOT break silicone seals on slip sections. Use care when removing termination cap from slip pipe. If slip section seals are broken during removal of the termination cap, vent may leak.

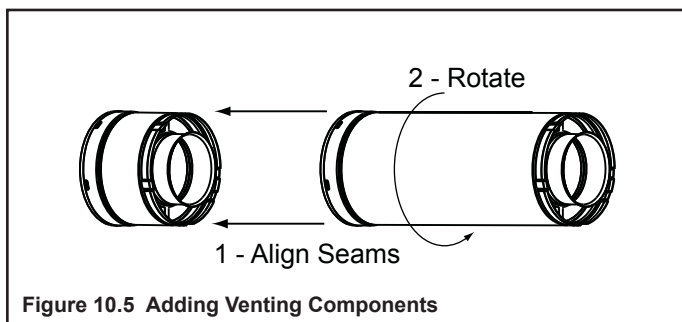

Figure 10.5 Adding Venting Components

C. Assemble Slip Sections

WARNING! Risk of Fire or Asphyxiation! Overlap pipe sections at least 1 1/2 in. (38 mm). Secure slip sections with two screws which must not exceed 1/2 in. (13 mm) in length. Use the pilot holes. Pipe could separate if not properly joined.

- Slide the inner flue of the slip section into the inner flue of the pipe section and the outer flue of the slip section over the outer flue of the pipe section. See Figure 10.6.
- Slide together to the desired length.

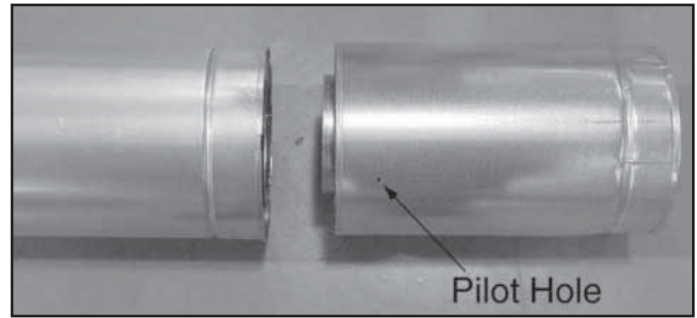

Figure 10.6 Slip Section Pilot Holes

- Maintain a 1-1/2 in. (38 mm) overlap between the slip section and the pipe section.
- Secure the pipe and slip section with two screws no longer than 1/2 in. (13 mm), using the pilot holes in the slip section. See Figure 10.7.

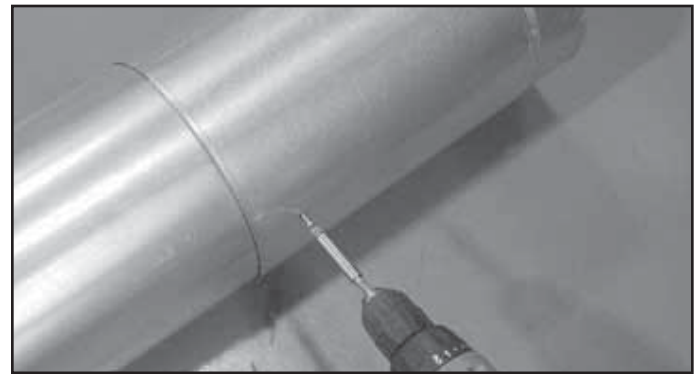

Figure 10.7 Screws into Slip Section

- Continue adding pipe as necessary following instructions in "Assemble Pipe Sections."

NOTICE: If slip section is too long, the inner and outer flues of the slip section can be cut to the desired length.

NOTICE: When installing a vent system with an HRC termination cap, all pipe system joints shall be sealed using a high temperature silicone sealant.

- Apply a bead of silicone sealant inside the female outer pipe joint prior to joining sections.
- Only outer pipes are sealed, sealing the inner flue is not required.
- All unit collar, pipe, slip section, elbow and cap outer flues shall be sealed.

D. Secure the Vent Sections

- Vertical runs originating off the top of the appliance, with no offsets, must be supported every 8 ft. (2.44 m) after the maximum allowed 25 ft. (7.62 m) of unsupported rise.
- Vertical runs originating off the rear of the appliance, or after any elbow, must be supported every 8 ft. (2.44 m).
- Horizontal runs must be supported every 5 feet (1.52 m).
- Vent supports or plumbers strap (spaced 120° apart) may be used to support vent sections. See Figures 7.8 and 7.9.
- Wall shield firestops may be used to provide horizontal support to vent sections.
- SLP ceiling firestops have tabs that may be used to provide vertical support.

WARNING! Risk of Fire, Explosion or Asphyxiation! Improper support may allow vent to sag and separate. Use vent run supports and connect vent sections per installation instructions. **DO NOT** allow vent to sag below connection point to appliance.

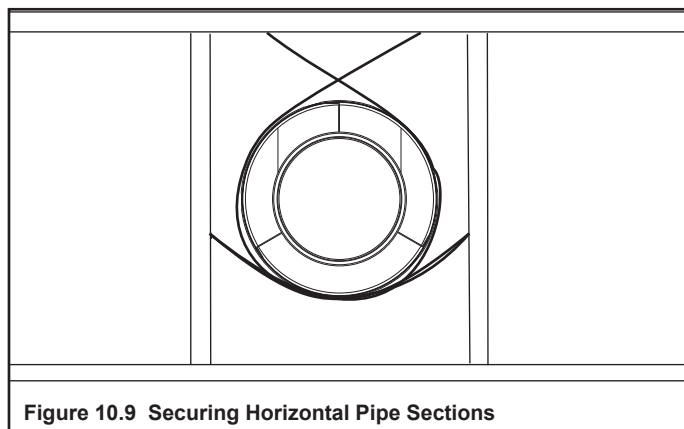
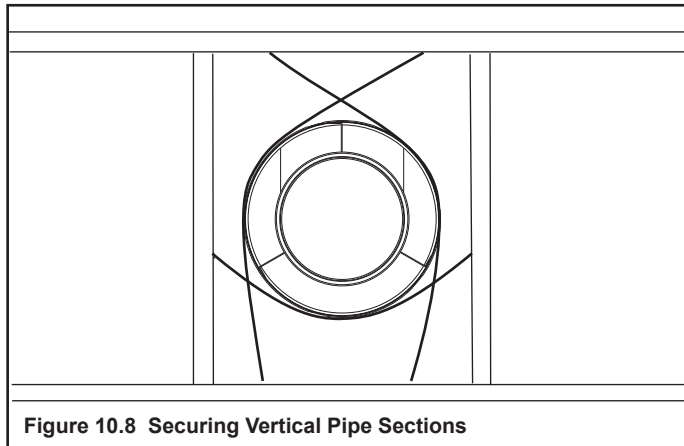

E. Disassemble Vent Sections

- Rotate either section (see Figure 10.10) so the seams on both pipe sections are aligned as shown in Figure 10.11.
- Pull carefully to separate the pieces of pipe.

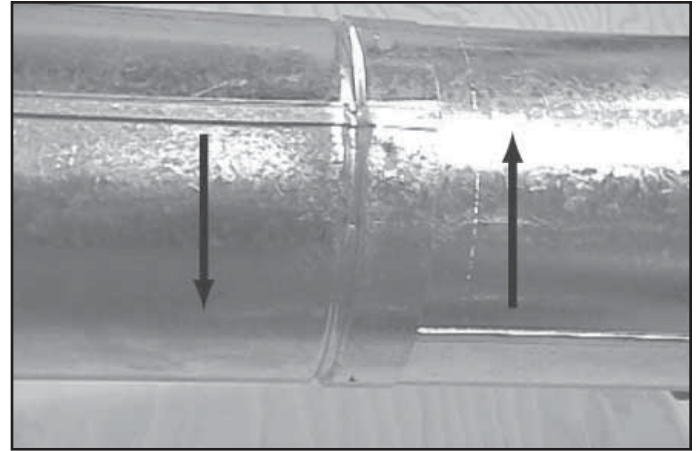

Figure 10.10 Rotate Seams for Disassembly

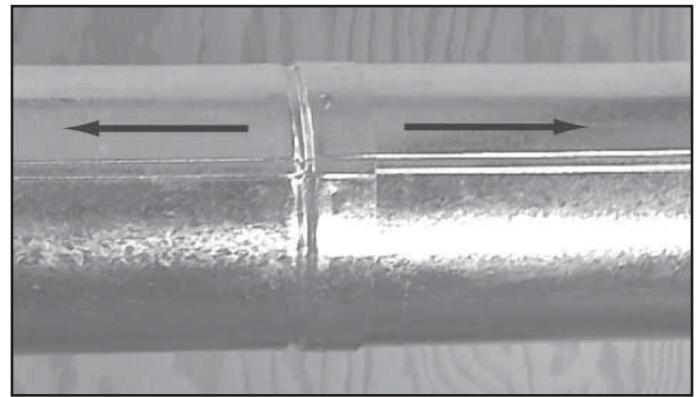

Figure 10.11 Align and Disassemble Vent Sections

F. Install Decorative Ceiling Components (SLP only)

A decorative ceiling thimble can be installed on a flat ceiling through which the vent passes. The decorative ceiling thimble is used to cover the firestop.

- Seal the gap between the vent pipe and firestop using high temperature silicone to prevent cold air infiltration.
- Install the decorative ceiling thimble by sliding it up to the ceiling and attaching it using the provided screws.

A decorative cathedral ceiling support box can be used where vertical vent runs pass through a cathedral ceiling.

- Use a plumb-bob to mark the center line of the venting system on the ceiling and drill a small hole through the ceiling and roof at this point. Locate the hole and mark the outline of the cathedral ceiling support box on the outside roof.
- Remove shingles or other roof covering as necessary to cut the rectangular hole for the support box. Cut the hole 1/8 in. (3 mm) larger than the support box outline.
- Lower the support box through the hole in the roof until its bottom is at least 2 in. (51 mm) below the ceiling (Figure 10.12).
- Level the support box both vertically and horizontally and temporarily tack it in place through the inside walls into the roof sheathing.
- Use tin snips to cut the support box from the top corners down to the roof line and fold the resulting flaps to the roof. See Figure 10.13.
- Nail the flaps to the roof AFTER running a bead of non hardening sealant between the flaps and the roof.

WARNING! Risk of Fire! Clean out ALL materials from inside the support box and complete the vertical vent run and termination.

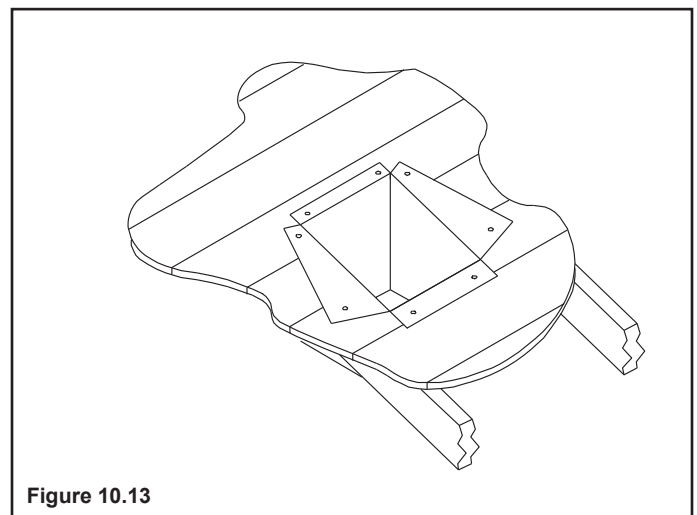
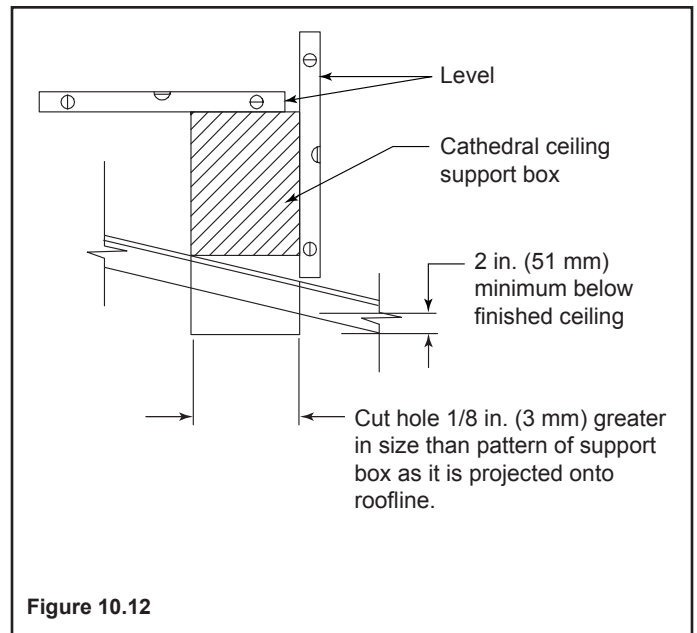

G. Install Metal Roof Flashing

- See minimum vent heights for various pitched roofs (Figure 10.14) to determine the length of pipe to extend through the roof.
- Slide the roof flashing over the pipe sections extending through the roof as shown in Figure 10.15.

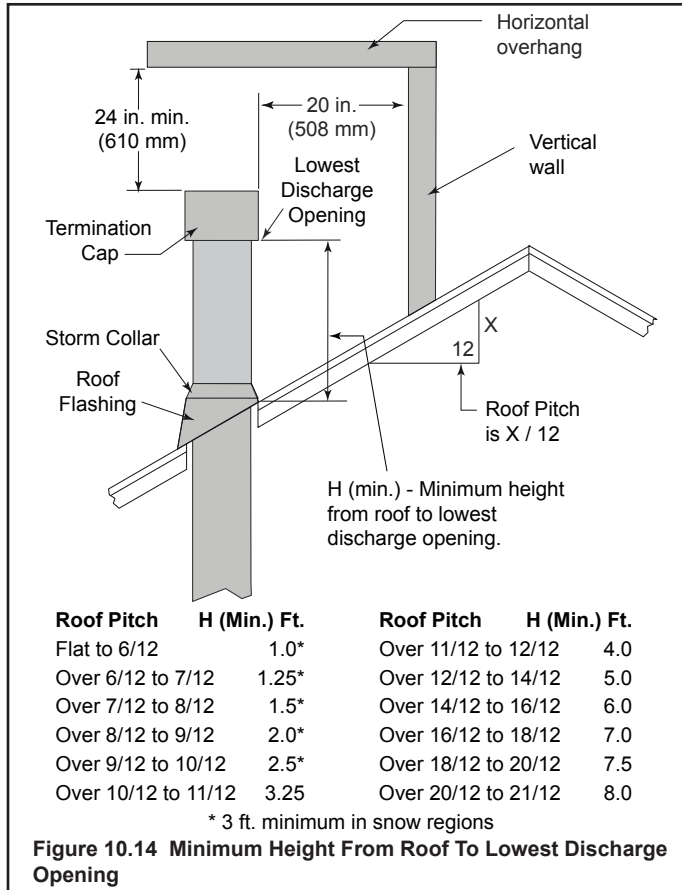

NOTICE: Failure to properly caulk the roof flashing and pipe seams may permit entry of water.

- Caulk the gap between the roof flashing and the outside diameter of the pipe.
- Caulk the perimeter of the flashing where it contacts the roof surface. See Figure 10.15.
- Caulk the overlap seam of any exposed pipe sections that are located above the roof line.

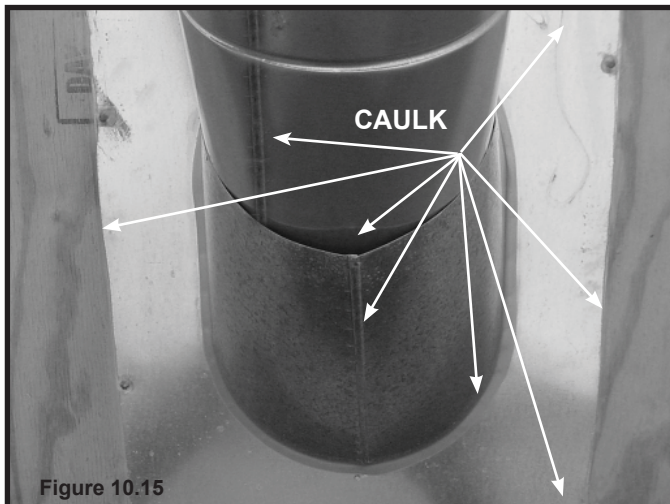

H. Assemble and Install Storm Collar

CAUTION! Risk of Cuts, Abrasions or Flying Debris. Wear protective gloves and safety glasses during installation. Sheet metal edges are sharp.

- Slide the storm collar onto the exposed pipe section and align brackets.
- Insert a bolt (provided) through the brackets and install nut. Do not completely tighten.



- Slide the assembled storm collar down the pipe section until it rests on the roof flashing (see Figure 10.17).
- Tighten nut and make sure the collar is tight against the pipe section.
- Caulk around the top of the storm collar. See Figure 10.17.

I. Install Vertical Termination Cap

- Attach the vertical termination cap by sliding the inner collar of the cap into the inner flue of the pipe section while placing the outer collar of the cap over the outer flue of the pipe section.
- Secure the cap by driving three self-tapping screws (supplied) through the pilot holes in the outer collar of the cap into the outer flue of the pipe (see Figure 10.17).



J. Heat Shield Requirements for Horizontal Termination

WARNING! Risk of Fire! To prevent overheating and fire, heat shields must extend through the entire wall thickness.

- **DO NOT** remove the heat shields attached to the wall shield firestop and the horizontal termination cap.
- Heat shields must overlap 1-1/2 in. (38 mm) minimum.

There are two sections of the heat shield. One section is factory-attached to the wall shield firestop. The other section is factory-attached to the cap. See Figure 10.18.

If the wall thickness does not allow the required 1-1/2 in. (38 mm) heat shield overlap when installed, an extended heat shield must be used.

- If the wall thickness is less than 4 in./102 mm (DVP) or 4-3/8 in./ 111 mm (SLP), the heat shields on the cap and wall shield firestop must be trimmed. A minimum 1-1/2 in. (38 mm) overlap **MUST** be maintained.
- Use an extended heat shield if the finished wall thickness is greater than 7-1/4 in. (184 mm).
- The extended heat shield may need to be cut to length maintaining sufficient length for a 1-1/2 in. (38 mm) overlap between heat shields.
- Attach the extended heat shield to either of the existing heat shields using the screws supplied with the extended heat shield. Refer to “Vent Components Diagrams” in the back of this manual.
- Rest the small leg on the extended heat shield on top of the pipe section to properly space it from the pipe section.

Important Notice: Heat shields may not be field constructed.

K. Install Horizontal Termination Cap

WARNING! Risk of Fire! The telescoping flue section of the termination cap **MUST** be used when connecting vent.

- 1-1/2 (38 mm) minimum overlap of flue telescoping section is required.

Failure to maintain overlap may cause overheating and fire.

- Vent termination must not be recessed in the wall. Siding may be brought to the edge of the cap base.
- Flash and seal as appropriate for siding material at outside edges of cap.

- When installing a horizontal termination cap, follow the cap location guidelines as prescribed by current **ANSI Z223.1** and **CAN/CGA-B149** installation codes and refer to Section 6 of this manual.

CAUTION! Risk of Burns! Local codes may require installation of a cap shield to prevent anything or anyone from touching the hot cap.

NOTICE: For certain exposures which require superior resistance to wind-driven rain penetration, a flashing kit and HRC caps are available. When penetrating a brick wall, a brick extension kit is available for framing the brick.

Note: When using termination caps with factory-supplied heat shield attached, no additional wall shield firestop is required on the exterior side of a combustible wall.

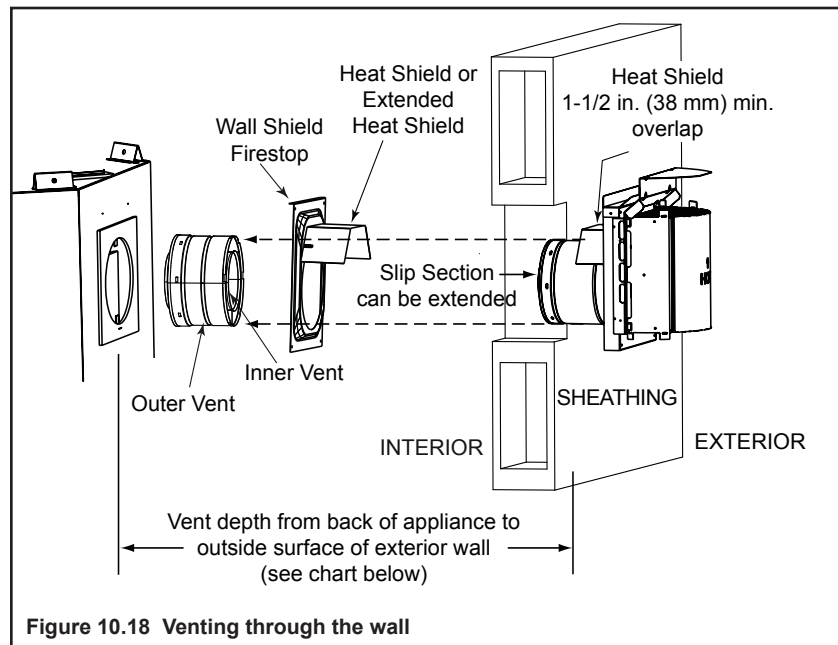

Figure 10.18 Venting through the wall

Cap Specification Chart (depth without using additional pipe sections)

NEVO Series	DVP-TRAPK1 Top Vent Depth	DVP-TRAP1 Rear Vent Depth	DVP-TRAPK2 Top Vent Depth	DVP-TRAP2 Rear Vent Depth	SLP-TRAP1 Top Vent Depth	SLP-TRAP2 Top Vent Depth
		4 1/2 to 6 3/8 in.	3 to 4 7/8 in.	6 7/8 to 10 7/8 in.	5 3/8 to 9 3/8 in.	2 to 3 7/8 in.
NEVO Series	DVP-HPC1 Top Vent Depth	DVP-HPC1 Rear Vent Depth	DVP-HPC2 Top Vent Depth	DVP-HPC2 Rear Vent Depth		
	4 1/2 to 6 5/8 in.	3 to 5 1/8 in.	6 5/8 to 10 3/4 in.	5 1/8 to 9 1/4 in.		

DVP-TRAP1 can adjust 1 1/2 in. (3 1/8 to 4 5/8)

DVP-TRAP2 can adjust 4 in. (5 3/8 to 9 3/8)

SLP-TRAP1 can adjust 1 5/8 in. (3 1/8 to 4 3/4)

SLP-TRAP2 can adjust 4 in. (5 1/4 to 9 1/4)

DVP-HPC1 can adjust 2 1/8 in. (4 1/4 to 6 3/8)

DVP-HPC2 can adjust 4 1/8 in. (6 3/8 to 10 1/2)

11 Shrouds

A. HHT Shrouds

- You may install a shroud with this fireplace. See Section 17.D. for a list of UL Listed shrouds. Follow the instructions included with these optional components

B. Field Constructed Shrouds

WARNING! Risk of Fire! Shrouds must be constructed as specified. Improper construction may overheat chase top.

- Chase top shrouds may be field constructed where permitted by regional building codes.

NOTICE: Some regional codes require an agency-Listed shroud. Consult your local building officials.

- The following field constructed shroud designs have been tested for Hearth Technologies fireplace systems and termination caps.
- The shrouds must be constructed from a minimum .018 in. (26 ga) thick aluminized steel.
- The wire mesh is optional but recommended and must be .018 in. thick minimum, 1/2 in. mesh.

Open Top Shroud (may be used with DVP-TV, DVP-TVHW, SLP-TVHW)

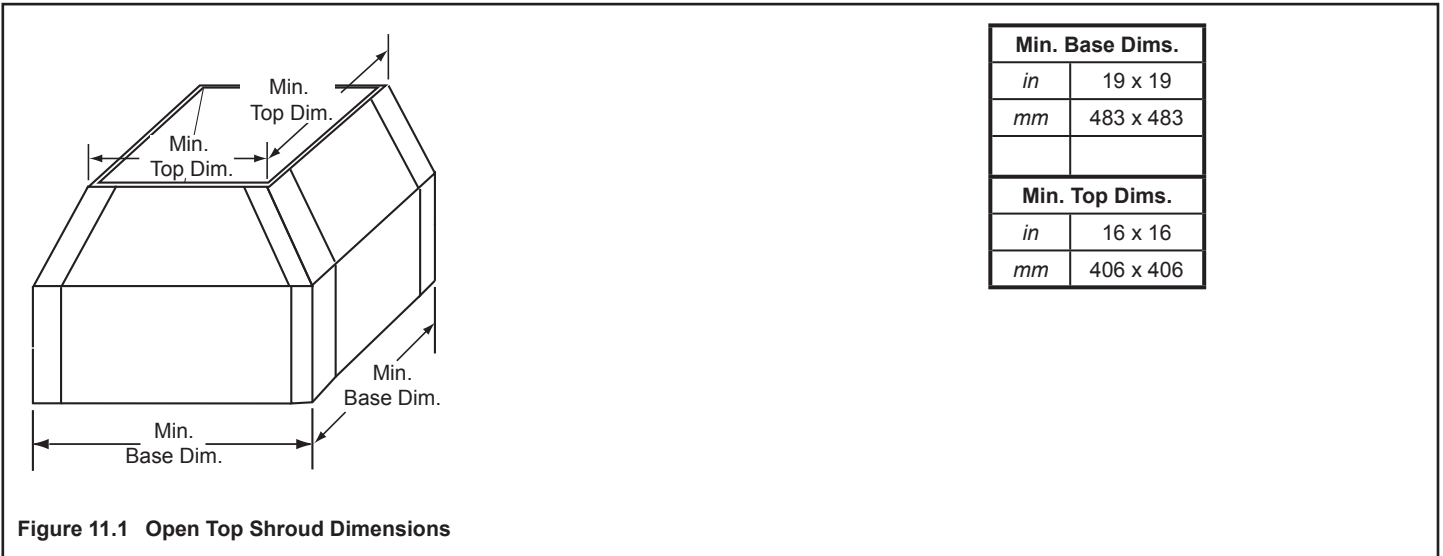

Mailbox Style Shroud (may be used with DVP-TV, DVP-TVHW, SLP-TVHW)

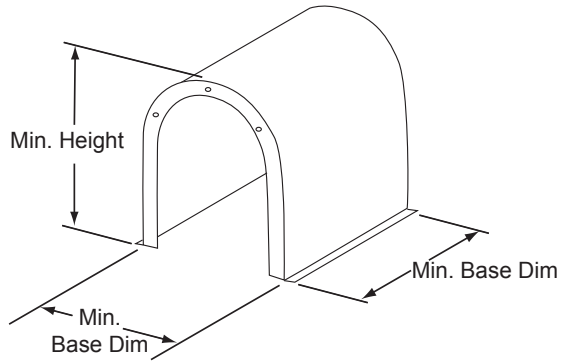

Min. Base Dims.	
<i>in</i>	20 x 20
<i>mm</i>	508 x 508
Min. Height	
<i>in</i>	18
<i>mm</i>	457

Figure 11.2 Mailbox Style Shroud Dimensions

Roofed Style Shroud (may be used with DVP-TV, DVP-TVHW, SLP-TVHW)

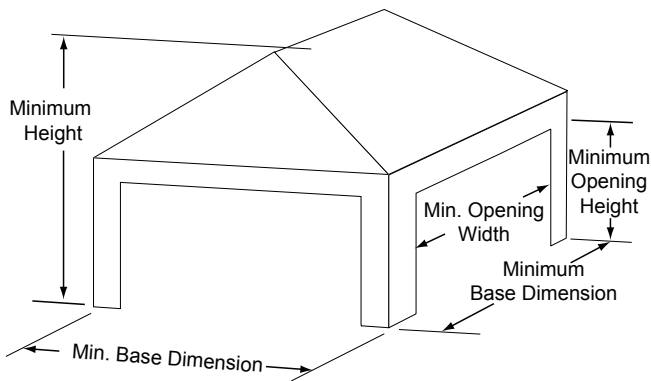

Min. Base Dims.	
<i>in</i>	20 x 20
<i>mm</i>	508 x 508
Min. Height	
<i>in</i>	18
<i>mm</i>	458
Min. Opening Width	
<i>in</i>	14
<i>mm</i>	356
Min. Opening Height	
<i>in</i>	10
<i>mm</i>	254

Figure 11.2 Roofed Style Shroud Dimensions

12 Gas Information

A. Fuel Conversion

- Make sure the appliance is compatible with available gas types.
- Conversions must be made by a qualified service technician using Hearth & Home Technologies specified and approved parts.

B. Gas Pressure

- Optimum appliance performance requires proper input pressures.
- Gas line sizing requirements will be determined in ANSI Z221.3 National Fuel Gas Code in the USA and CAN/CGA B149 in Canada.
- Pressure requirements are:

Gas Pressure	Natural Gas	Propane
Minimum inlet pressure	5.0 in. w.c.	11.5 in. w.c.
Maximum inlet pressure	10.0 in. w.c.	13.0 in. w.c.
Manifold pressure	3.5 in. w.c.	10.0 in. w.c.

WARNING! Risk of Fire or Explosion! High pressure will damage valve. Low pressure may cause explosion.

- Verify inlet pressures. Verify minimum pressures when other household gas appliances are operating.
- Install regulator upstream of valve if line pressure is greater than 1/2 psig.

⚠ WARNING



Fire Risk.
Explosion Hazard.
High pressure will damage valve.

- Disconnect gas supply piping BEFORE pressure testing gas line at test pressures above 1/2 psig.
- Close the manual shutoff valve BEFORE pressure testing gas line at test pressures equal to or less than 1/2 psig.

Note: Have the gas supply line installed in accordance with local codes, if any. If not, follow ANSI Z223.1. Installation should be done by a qualified installer approved and/or licensed as required by the locality. (In the Commonwealth of Massachusetts installation must be performed by a licensed plumber or gas fitter).

Note: A listed (and Commonwealth of Massachusetts approved) 1/2 in. (13 mm) T-handle manual shut-off valve and flexible gas connector are connected to the 1/2 in. (13 mm) control valve inlet.

- **If substituting for these components, please consult local codes for compliance.**

C. Gas Connection

- Refer to Reference Section 17.A. for location of gas line access in appliance.
- Gas line may be run through knockout(s) provided.
- The gap between supply piping and gas access hole may be caulked with caulk with a minimum of 300°F continuous exposure rating or stuffed with non-combustible, unfaced insulation to prevent cold air infiltration.
- Ensure that gas line does not come in contact with outer wrap of the appliance. Follow local codes.
- Pipe incoming gas line into valve compartment.
- Connect incoming gas line to the 1/2 in. (13 mm) connection on manual shutoff valve.

WARNING! Risk of Fire or Explosion! Support control when attaching pipe to prevent bending gas line.

- A small amount of air will be in the gas supply lines.

WARNING! Risk of Fire or Explosion! Gas build-up during line purge could ignite.

- Purge should be performed by qualified service technician.
- Ensure adequate ventilation.
- Ensure there are no ignition sources such as sparks or open flames.

Light the appliance. It will take a short time for air to purge from lines. When purging is complete the appliance will light and operate normally.

WARNING! Risk of Fire, Explosion or Asphyxiation! Check all fittings and connections with a non-corrosive commercially available leak-check solution. DO NOT use open flame. Fittings and connections could have loosened during shipping and handling.

WARNING! Risk of Fire! DO NOT change valve settings. This valve has been preset at the factory.

D. High Altitude Installations

NOTICE: If the heating value of the gas has been reduced, these rules do not apply. Check with your local gas utility or authorities having jurisdiction.

When installing above 2000 feet elevation:

- In the USA: Reduce burner orifice 4% for each 1000 feet above 2000 feet.
- In CANADA: Reduce burner orifice 10% for elevations between 2000 feet and 4500 feet. Above 4500 feet, consult local gas utility.

13 Electrical Information

A. Wiring Requirements

NOTICE: *This appliance must be electrically wired and grounded in accordance with local codes or, in the absence of local codes, with National Electric Code ANSI/NFPA 70-latest edition or the Canadian Electric Code CSA C22.1.*

- Wire the appliance junction box to 120 VAC. This is required for use of optional accessories (standing pilot ignition) or proper operation of the appliance (Intellifire ignition).
- A 120 VAC circuit for this product must be protected with ground-fault circuit-interrupter protection, in compliance with the applicable electrical codes, when it is installed in locations such as in bathrooms or near sinks.
- Low voltage and 120 VAC voltage cannot be shared within the same wall box.

WARNING! Risk of Shock or Explosion! DO NOT wire 120V to the valve or to the appliance wall switch. Incorrect wiring will damage controls.

B. IntelliFire™ Plus Ignition System Wiring

- Wire the appliance junction box to 120 VAC for proper operation of the appliance.

WARNING! Risk of Shock or Explosion! DO NOT wire IPI controlled appliance junction box to a switched circuit. Incorrect wiring will override IPI safety lockout.

- Refer to Figure 13.1, IntelliFire™ Plus intermittent pilot ignition (IPI) wiring diagram.
- This appliance is equipped with an Intellifire control valve which operates on a 6-volt system.
- Plug the 6-volt DC power supply into the appliance junction box to supply power
- For battery backup protection, install four AA-cell batteries (not included) into the battery pack before use. Remove batteries if the fireplace will not be used for an extended period of time.

NOTICE: *Battery polarity must be correct or module damage will occur.*

C. Optional Accessories Requirements

- This appliance may be used with a wall switch, wall mounted thermostat and/or a remote control.
- Wiring for optional Hearth & Home Technologies Inc. approved accessories should be done now to avoid reconstruction. Follow instructions that come with those accessories.
- Hearth & Home Technologies recommends that IntelliFire™ Plus wireless controls be used for their features and functionality with the IntelliFire™ Plus ignition system.
- A standard ON/OFF switch is compatible.

D. Electrical Service and Repair

WARNING! Risk of Shock! Label all wires prior to disconnection when servicing controls. Wiring errors can cause improper and dangerous operation. Verify proper operation after servicing.

WARNING! Risk of Shock! Replace damaged wire with type 105° C rated wire. Wire must have high temperature insulation.

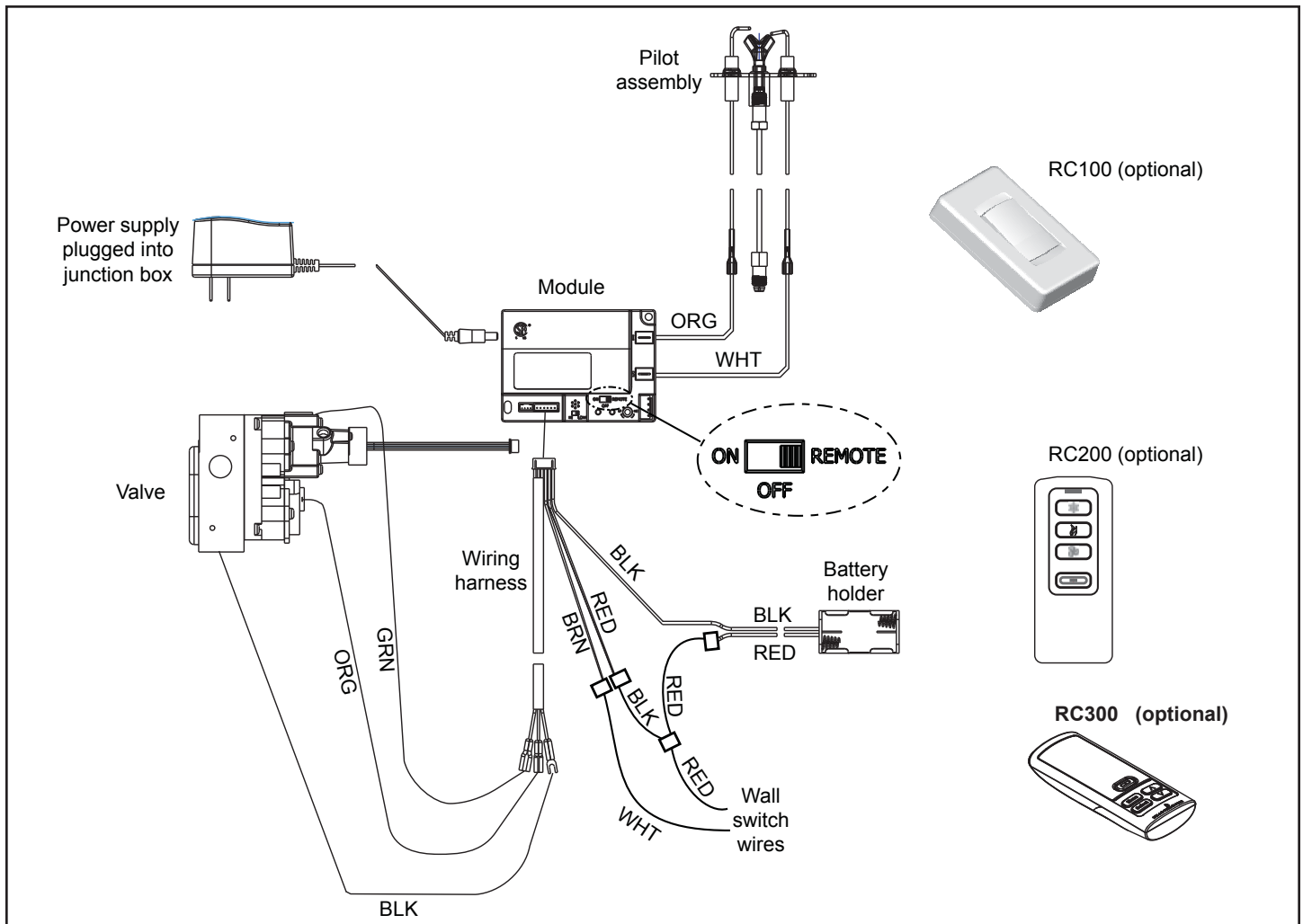

➔ Figure 13.1 IntelliFire™ Plus Intermittent Pilot Ignition (IPI) Wiring Diagram

E. Junction Box Installation

If the box is being wired from the **OUTSIDE** of the appliance:

- Remove the cover plate located on the outer shell - right side (see Figure 13.2).
- Install the supplied Romex™ connector in the cover plate.
- Make all necessary wire connections and reattach the cover plate to the outer shell.

If the box is being wired from the **INSIDE** of the appliance:

- Remove the screw attaching the junction box/receptacle to the outer shell, rotate the junction box inward to disengage it from the outer shell (see Figure 13.2).
- Pull the electrical wires from outside the appliance through this opening into the valve compartment. See Figure 13.4.

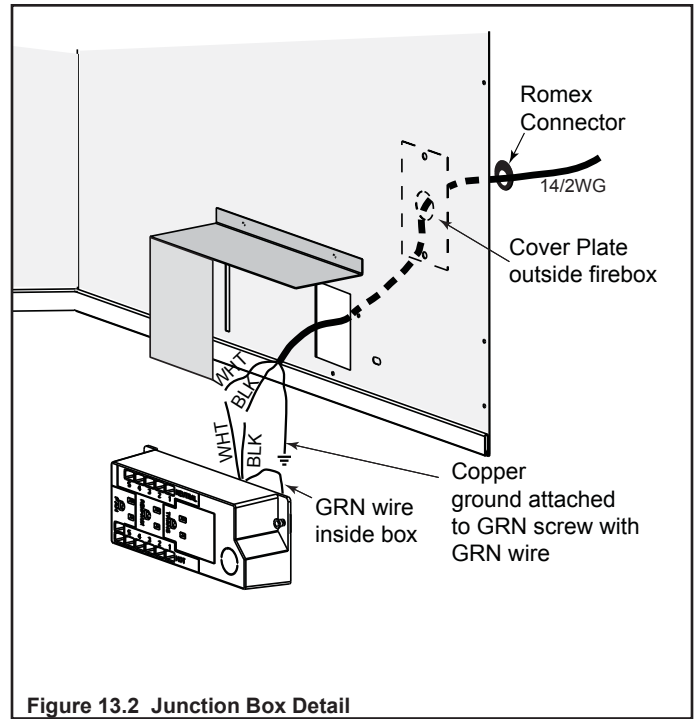

Figure 13.2 Junction Box Detail

F. Wall Switch Installation for Fan (Optional)

If the box is being wired to a wall mounted switch for use with a fan, see Figure 13.3:

- The power supply for the appliance must be brought into a switch box.
- The power can then be supplied from the switch box to the appliance using a minimum of 14-3 with ground wire.
- At the switch box connect the black (hot) wire and red (switch leg) wire to the wall switch as shown.
- At the appliance connect the black (hot), white (neutral) and green (ground) wires to the junction box as shown.
- Add a 1/4 in. insulated female connector to the red (switch leg) wire, route it through the knockout in the face of the junction box, and connect to the top fan switch connector (1/4 in. male) as shown.

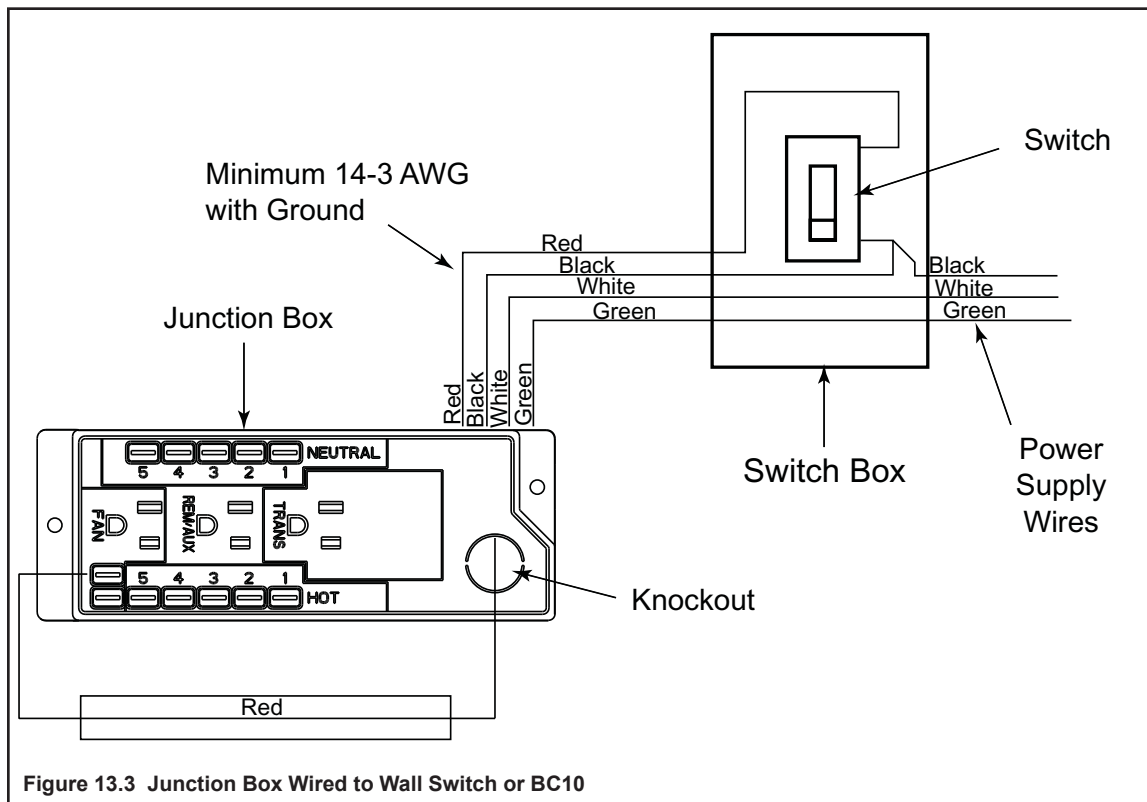

Figure 13.3 Junction Box Wired to Wall Switch or BC10

14 Finishing

A. Mantel and Wall Projections

WARNING! Risk of Fire! Comply with all minimum clearances to combustibles as specified. Framing or finishing material closer than the minimums listed must be constructed entirely of non-combustible materials (i.e., steel studs, concrete board, etc).

Mantels

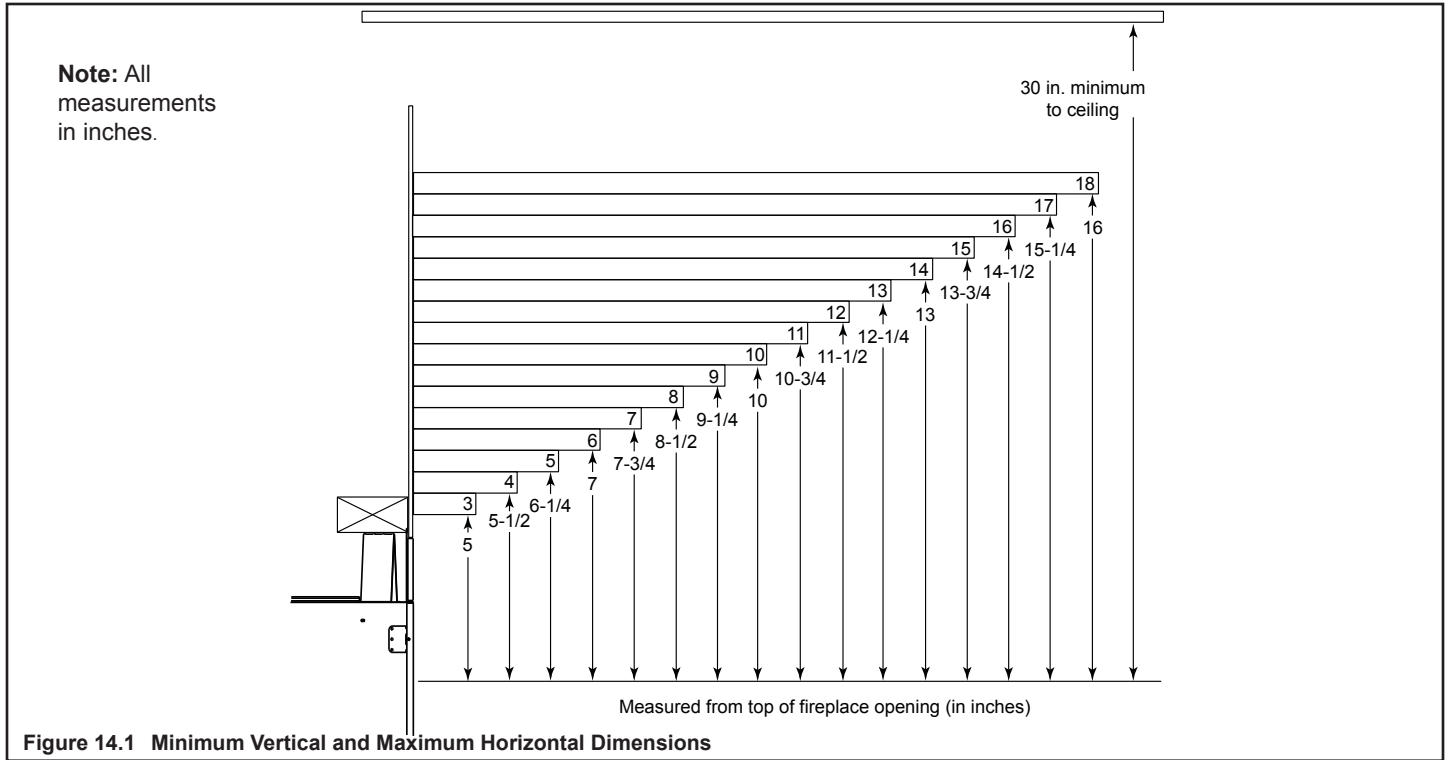

Mantel Legs or Wall Projections

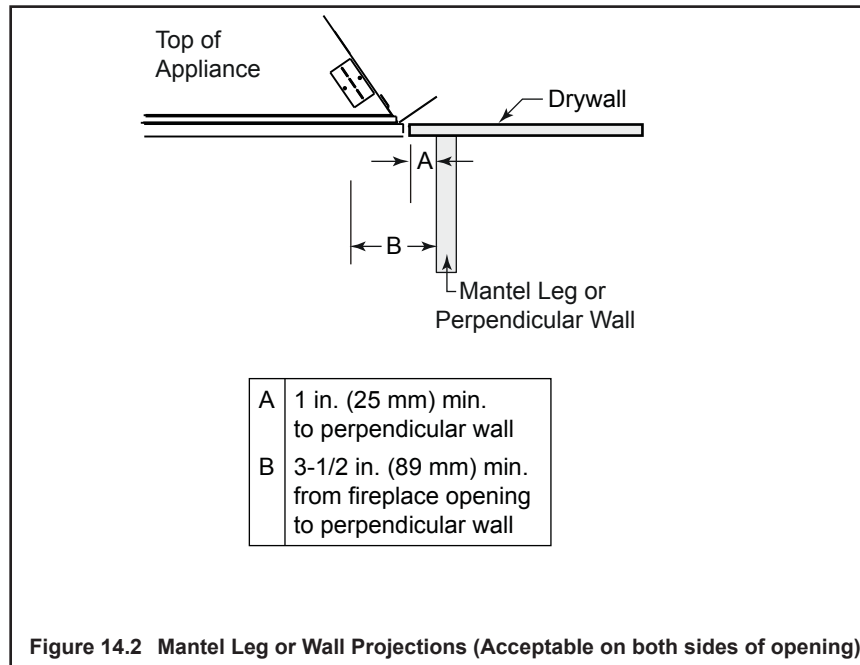

B. Facing Material

- Metal front faces may be covered with non-combustible materials only.
- Facing and/or finishing materials must not interfere with air flow through louvers, operation of louvers or doors, or access for service.
- Facing and/or finishing materials must never overhang into the glass opening.
- Observe all clearances when applying combustible materials.

Note: If using the optional finishing trim for the Modern Front facing, finish wall material must not be installed within 3 in. (76 mm) of the fireplace opening. See Figure 14.5.

- Seal joints between the finished wall and appliance top and sides using a 300 °F minimum sealant. Refer to Figure 14.4.

WARNING! Risk of Fire! DO NOT apply combustible materials beyond the minimum clearances. Comply with all minimum clearances to combustibles as specified in this manual. Overlapping materials could ignite and will interfere with proper operation of doors and louvers.

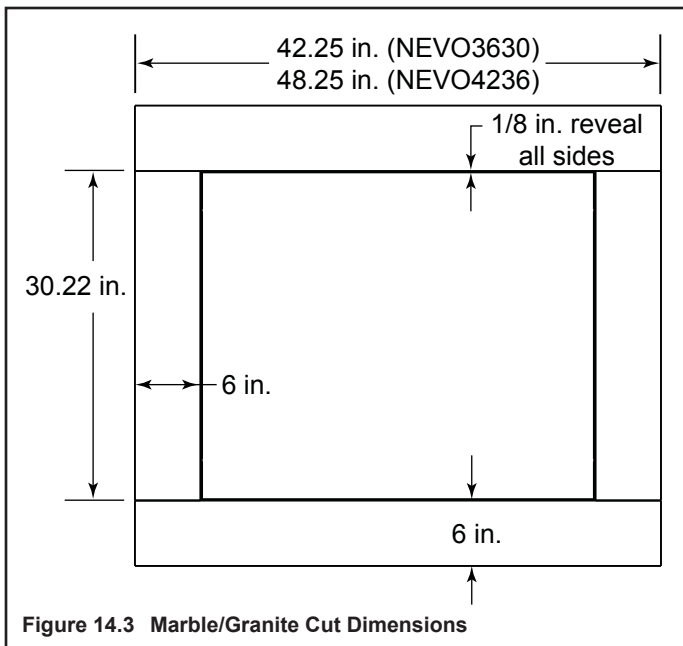

- Figure 14.3 shows the dimensions for cutting marble/granite if the optional Finishing Trim is not used.
- The dimensions given assume a 1/8 in. reveal around the fireplace opening.

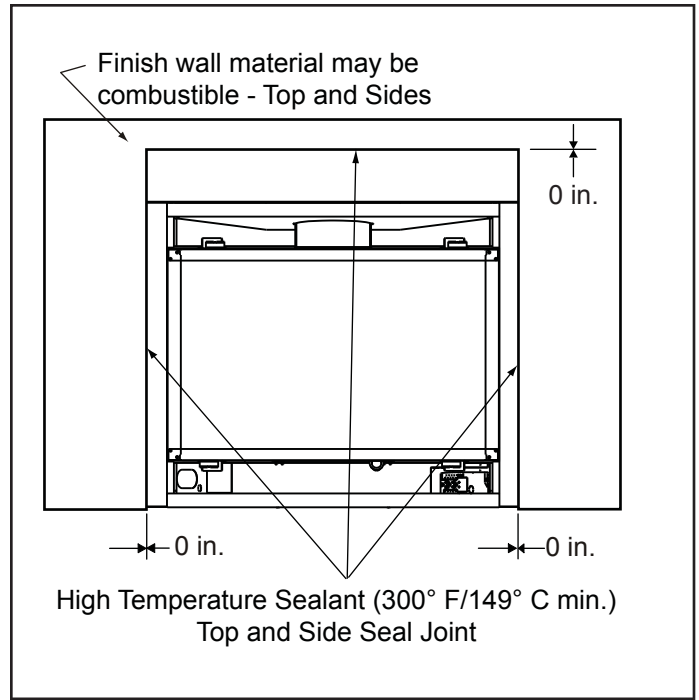

Figure 14.4 Non-combustible Facing Diagram

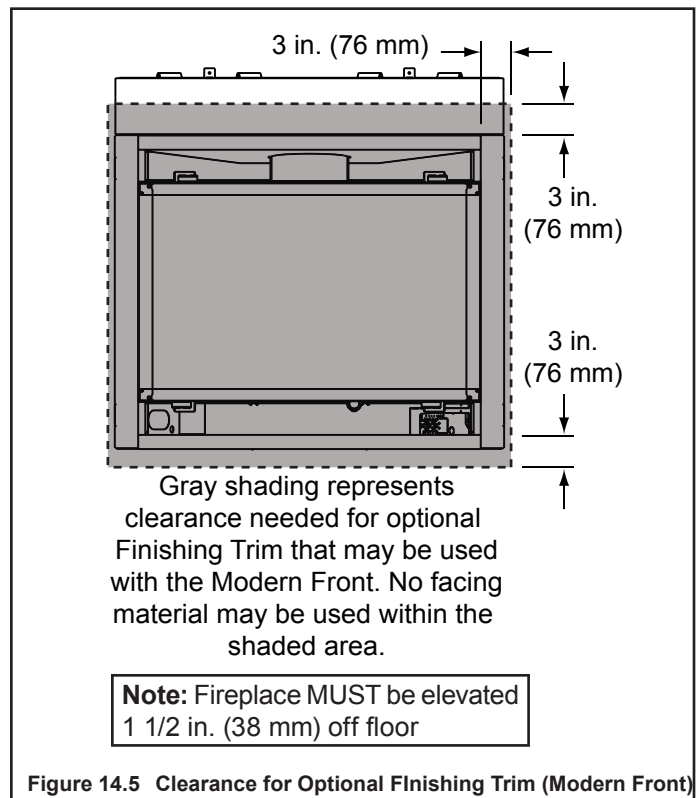

Figure 14.5 Clearance for Optional Finishing Trim (Modern Front)

15 Appliance Setup

A. Remove the Packaging

Remove the shrink film, corrugated top cap, bottom cap and column protectors from the appliance. The appliance should look as shown in Figure 15.1.



Figure 15.1 Appliance Unwrapped

B. Remove the Shipping Materials

Remove the shipping materials from inside and underneath the firebox.

C. Removing Fixed Glass Assembly

WARNING! Risk of Asphyxiation! Handle fixed glass assembly with care. Inspect the gasket to ensure it is undamaged and inspect the glass for cracks, chips or scratches.

DO NOT:

- Strike, slam or scratch glass
- Operate fireplace with glass removed, cracked, broken or scratched.

Replace fixed glass assembly as a complete assembly.

- Pull the four glass assembly latches out of the groove on the glass frame. Refer to Figure 15.2.
- Remove the glass assembly from the appliance.

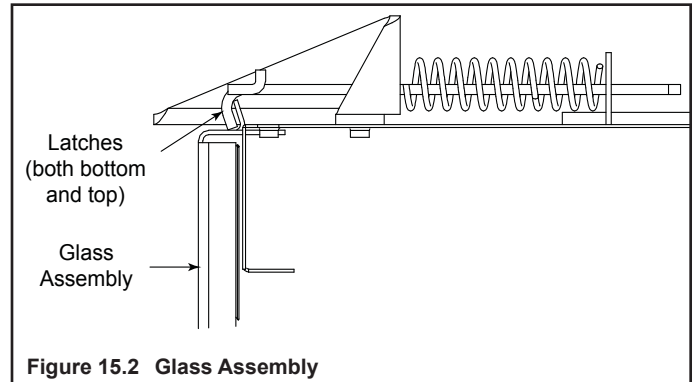

Figure 15.2 Glass Assembly

D. Remove Glass Media Package

The glass media package is shipped inside the firebox. Refer to Figure 15.1.

E. Clean the Appliance

Clean/vacuum any sawdust that may have accumulated inside the firebox or underneath in the control cavity.

F. Accessories

Install approved accessories per instructions included with the accessories. Refer to Section 17.

WARNING! Risk of Fire and Electric Shock! Use ONLY Hearth & Home Technologies-approved optional accessories with this appliance. Using non-listed accessories could result in a safety hazard and will void the warranty.

G. Place the Glass Media

WARNING! Risk of Explosion! Follow glass media placement instructions.

- DO NOT place glass media in pilot opening.
- DO NOT place glass media where they might fall into pilot opening.
- DO NOT use any media other than the glass media supplied with this fireplace.
- DO NOT place more than one layer of glass media on top of burner.

Improperly placed glass media interferes with proper burner operation. Delayed ignition could occur.

WARNING! Choking Hazard! Keep glass media out of reach of children.

Cleaning the Glass Media

During shipment of the glass media, dust and debris can accumulate. We recommend the glass media be rinsed thoroughly with water to remove dust and small glass particles.

- Place the glass media into a bucket and rinse thoroughly with water.
- Allow the glass media to dry before installing it into the fireplace.

Install the Glass Media

- Remove the screws holding the glass media placement jig. Leave the jig in place until the glass media is placed.

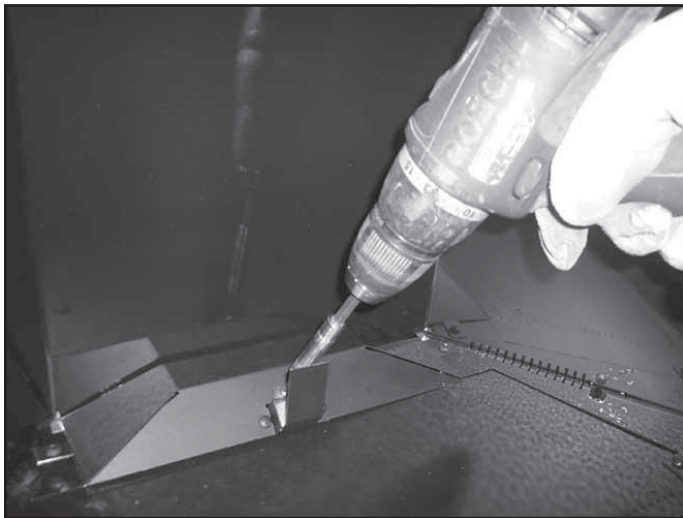

Figure 15.3 Remove Screws from Jig

- Open the bag of glass media and place on the burner/hearth pan area.
- Spread the glass media over the entire area. **Make sure glass media is only one layer thick on top of the burner.**

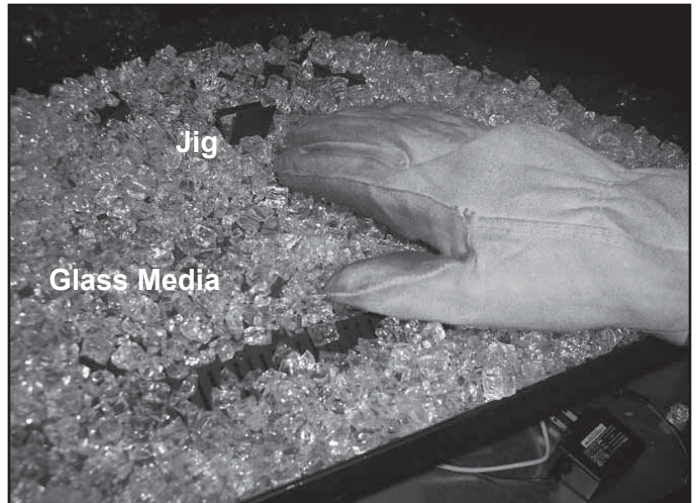

Figure 15.4 Place & Spread Glass Media

- Remove the glass media placement jig.



Figure 15.5 Remove Jig

- Make sure the area in front of the pilot remains free of glass media.



Figure 15.6 Pilot Open & Glass-Media-Free

H. Replacing Fixed Glass Assembly

- Set the glass panel on the lower two or four glass assembly latches, ensuring the glass panel is centered in the opening.
- Replace glass latches. See Figure 15.2.

I. Air Shutter Setting

Air shutter setting should be adjusted by a qualified installer at the time of installation.

- The air shutter is set at the factory for minimum vertical vent run.
- Adjust air shutter for longer vertical runs. See Figure 15.7.
- Turn the thumbscrew to open and close.

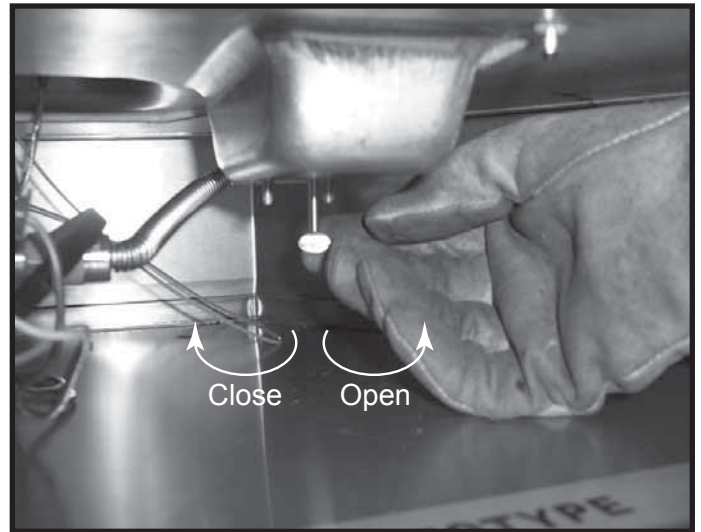

Figure 15.7 Adjusting Air Shutter

16 Troubleshooting

With proper installation, operation, and maintenance your gas appliance will provide years of trouble-free service. If you do experience a problem, this troubleshooting guide will assist a qualified service technician in the diagnosis of a problem and the corrective action to be taken. This troubleshooting guide can only be used by a qualified service technician. Contact your dealer to arrange a service call by a qualified service technician.

A. Intellifire™ Plus Intermittent Ignition System

Symptom	Possible Cause	Corrective Action
1. Pilot won't light. The ignitor/module makes noise, but no spark.	A. Incorrect wiring.	Verify "S" wire (white) for sensor and "I" wire (orange) for ignitor are connected to correct terminals on module and pilot assembly.
	B. Loose connections or electrical shorts in the wiring.	Verify no loose connections or electrical shorts in wiring from module to pilot assembly. Verify connections underneath pilot assembly are tight; also verify igniter and flame sense wires are not grounding out to metal chassis, pilot burner, pilot enclosure, mesh screen if present, or any other metal object.
	C. Ignitor gap is too large.	Verify gap of igniter to right side of pilot hood. The gap should be approximately .095 in. (2.41 mm) to .135 in. (3.43 mm).
2. Pilot won't light, there is no noise or spark.	A. No power or transformer installed incorrectly.	Verify that transformer is installed and plugged into module. Check voltage of transformer at connection to module. Acceptable readings of a good transformer are between 6.4 and 6.6 volts DC.
	B. A shorted or loose connection in wiring configuration or wiring harness.	Remove and reinstall the wiring harness that plugs into module. Verify there is a tight fit. Verify pilot assembly wiring to module. Remove and verify continuity of each wire in wiring harness. Replace any damaged components.
	C. Improper wall switch wiring.	Verify that 120/VAC power is "ON" to junction box.
	D. Module not grounded.	Verify black ground wire from module wire harness is grounded to metal chassis of appliance.
3. Pilot sparks, but Pilot will not light.	A. Gas supply.	Verify that incoming gas line ball valve is "open". Verify that inlet pressure reading is within acceptable limits.
	B. Ignitor gap is too large.	Verify gap of igniter to right side of pilot hood. The gap should be approximately .095 in. (2.41 mm) to .135 in. (3.43 mm).
	C. Module is not grounded.	Verify module is securely grounded to metal chassis of appliance.
	D. Pilot valve solenoid	Verify that 1.5 to 1.8 VDC is supplied to pilot solenoid from module. If below 1.5 volts, replace module. If 1.5 volts or greater, replace valve.

Intellifire Plus™ Intermittent Pilot Ignition System - (continued)

<p>4. Pilot lights but continues to spark, and main burner will not ignite. (If the pilot continues to spark after the pilot flame has been lit, flame rectification has not occurred.)</p>	<p>A. A shorted or loose connection in flame sensing rod.</p>	<p>Verify all connections to wiring diagram in manual. Verify connections underneath pilot assembly are tight. Verify flame sense or igniter wires are not grounding out to metal chassis, pilot burner, pilot enclosure or screen if present, or any other metal object.</p>
	<p>B. Poor flame rectification or contaminated flame sensing rod.</p>	<p>With fixed glass assembly in place, verify that flame is engulfing flame sensing rod on left side of pilot hood. Flame sensing rod should glow shortly after ignition. With a multi-meter, verify that current in series between module and sense lead is at least 0.14 microamps. Verify correct pilot orifice is installed and gas inlet is set to pressure specifications. Polish flame sensing rod with fine steel wool to remove any contaminants that may have accumulated on flame sensing rod.</p>
	<p>C. Module is not grounded.</p>	<p>Verify module is securely grounded to metal chassis of appliance. Verify that wire harness is firmly connected to the module.</p>
	<p>D. Damaged pilot assembly or contaminated flame sensing rod.</p>	<p>Verify that ceramic insulator around the flame sensing rod is not cracked, damaged, or loose. Verify connection from flame sensing rod to white sensor wire. Polish flame sensing rod with fine steel wool to remove any contaminants that may have accumulated on flame sensing rod. Verify continuity with a multi-meter with ohms set at lowest range. Replace pilot if any damage is detected.</p>

17 Reference Materials

A. Appliance/Decorative Front Dimension Diagrams

Dimensions are actual appliance dimensions. Use for reference only. For framing dimensions and clearances refer to Section 5.

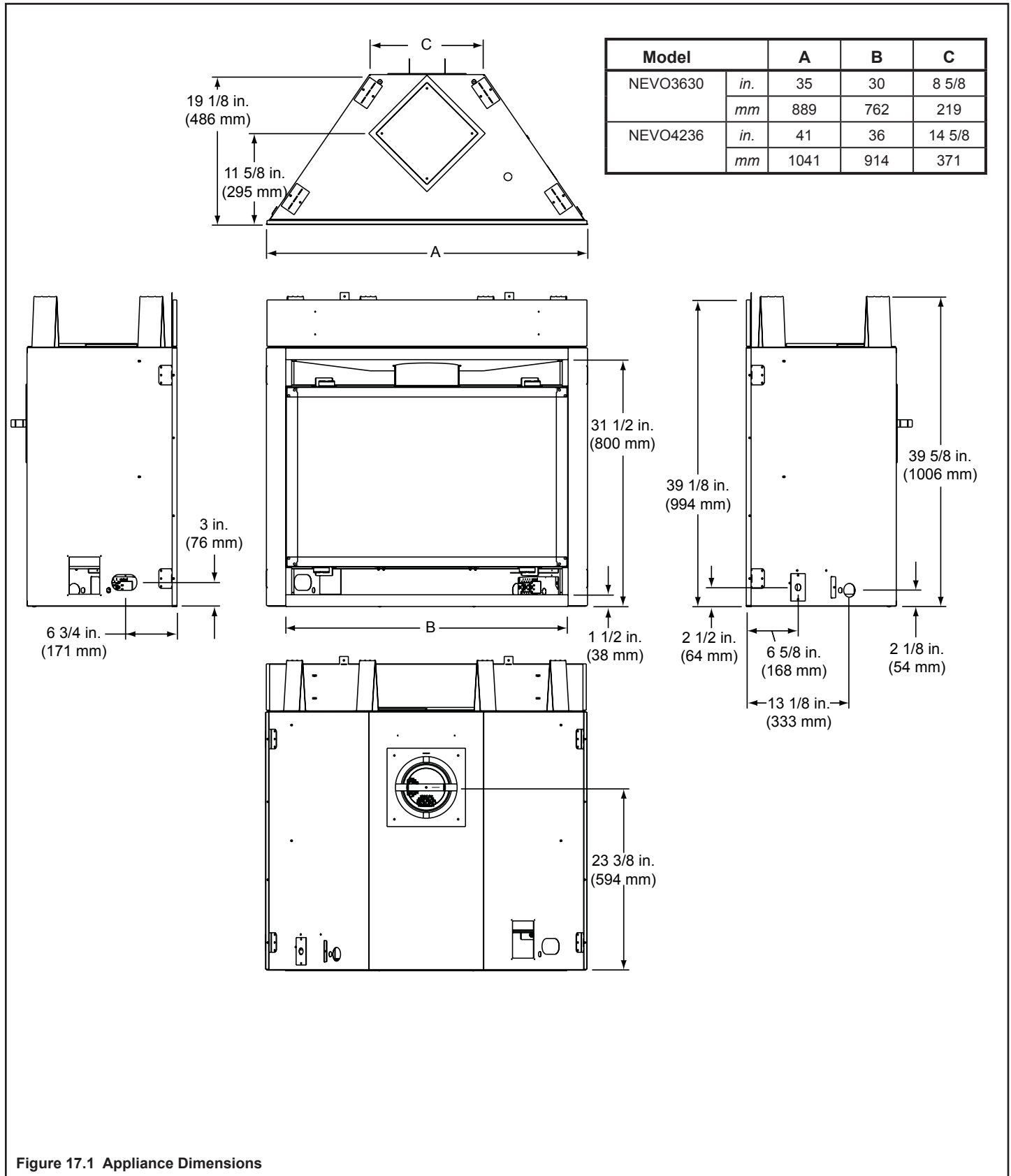
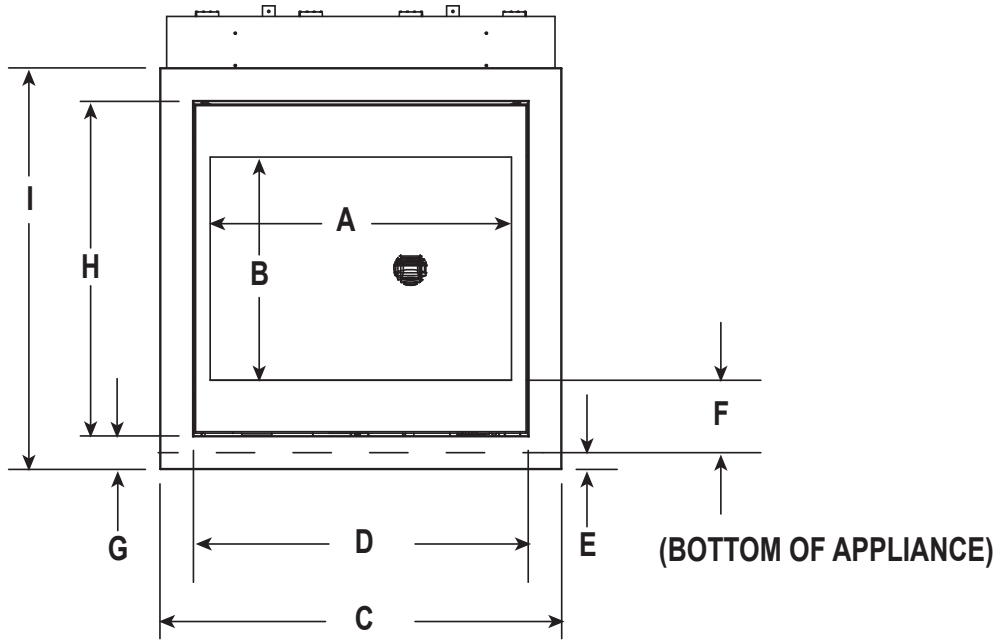

Figure 17.1 Appliance Dimensions

DF-MR30/DF-MR30-SS DECORATIVE FRONTS



		A	B	C	D	E	F	G	H	I
NEVO3630i	in.	27	20	36	30	1-1/2	6-1/2	3	30	36
	mm	686	508	914	762	38	165	76	762	914

DF-MR36/DF-MR36-SS DECORATIVE FRONTS

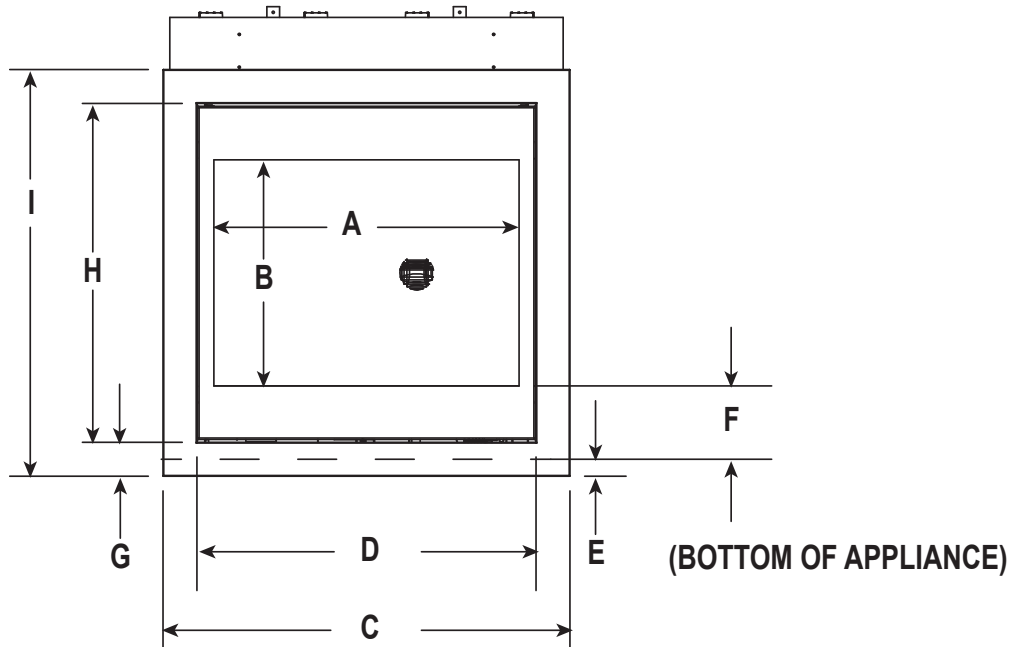

		A	B	C	D	E	F	G	H	I
NEVO4236i	in.	33	20	42	36	1-1/2	6-1/2	3	30	36
	mm	838	508	1067	914	38	165	76	762	914

Figure 3.2 Decorative Front Dimensions (Including Surround)

B. Vent Components Diagrams

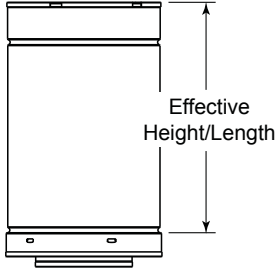

DVP Pipe
(see chart)

Effective Height/Length		
Pipe	inches	mm
DVP4	4	102
DVP6	6	152
DVP12	12	305
DVP24	24	610
DVP36	36	914
DVP48	48	1219
DVP6A	3 - 6	76 - 152
DVP12A	3 - 12	76 - 305

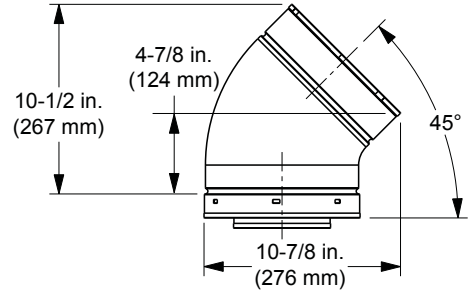

DVP45
45° Elbow

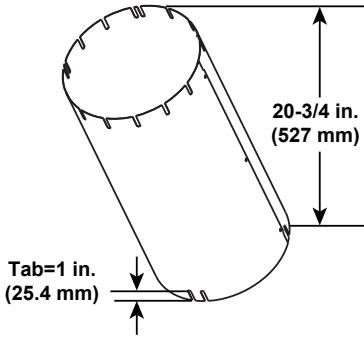

Finished Height: 19-3/4 in./502 mm
UNIV-AS2 (Attic Insulation Shield)

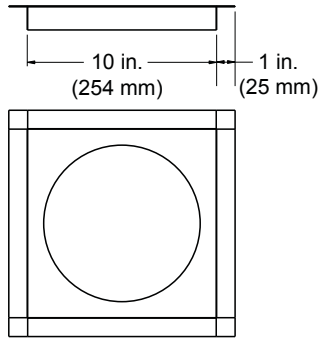

DVP-FS
Ceiling Firestop

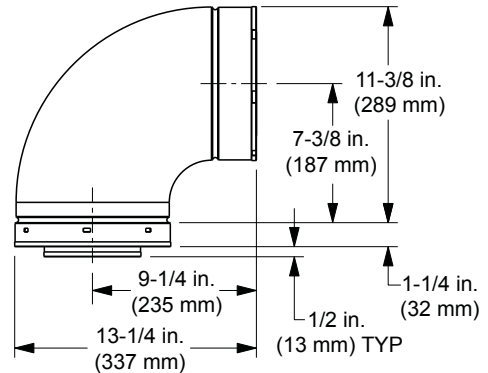

DVP90ST
90° Elbow

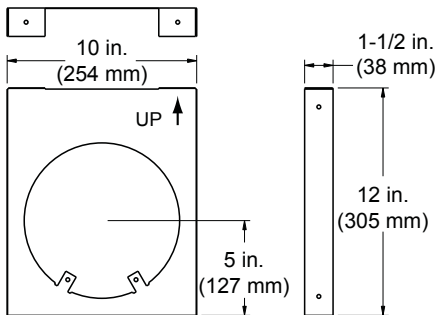

DVP-HVS
Vent Support

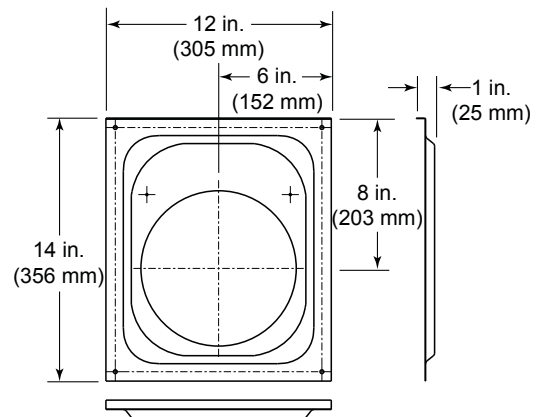

DVP-WS
Wall Shield Firestop

Figure 17.2 DVP Vent Components

B. Vent Components Diagrams (continued)

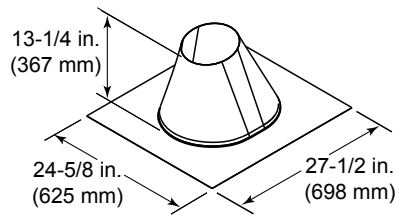

RF6M
Roof Flashing Multi-pak

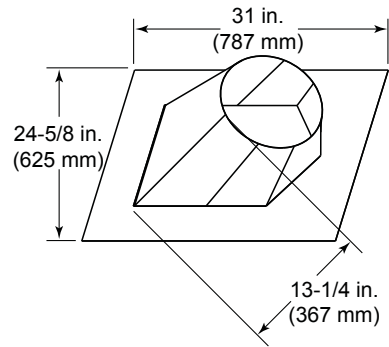

RF12M
Roof Flashing Multi-pak

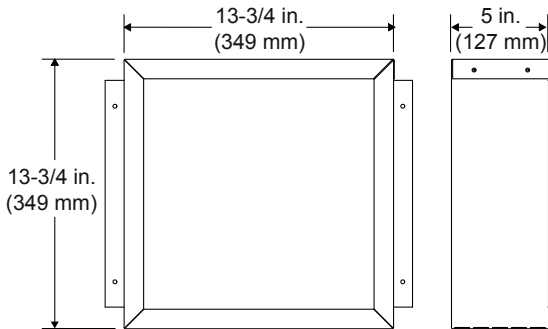

BEK
Trap Cap Brick Extension

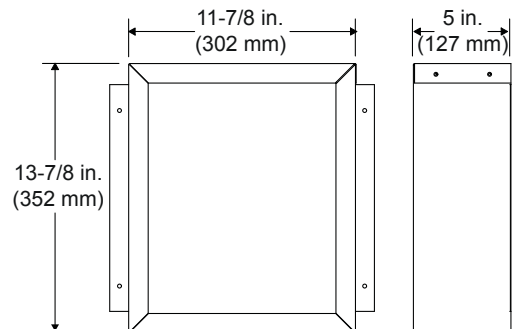

DVP-BEK2
DVP-HPC Cap Brick Extension

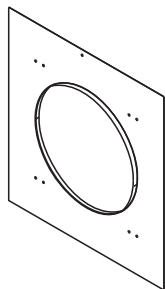

DVP-TRAPFL
Flashing

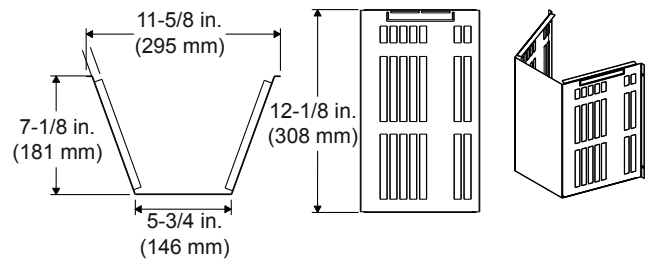

COOL-ADDM
Cap Shield

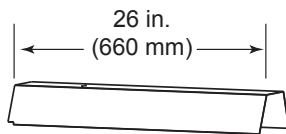

DVP-HSM-B
Extended Heat Shield

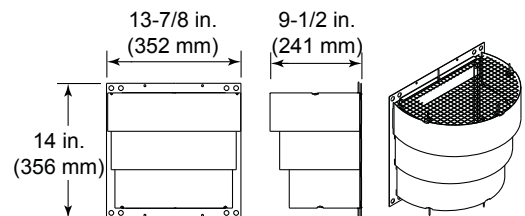

DRC-RADIUS
Cap Shield

Figure 17.3 DVP Vent Components

B. Vent Components Diagrams (continued)

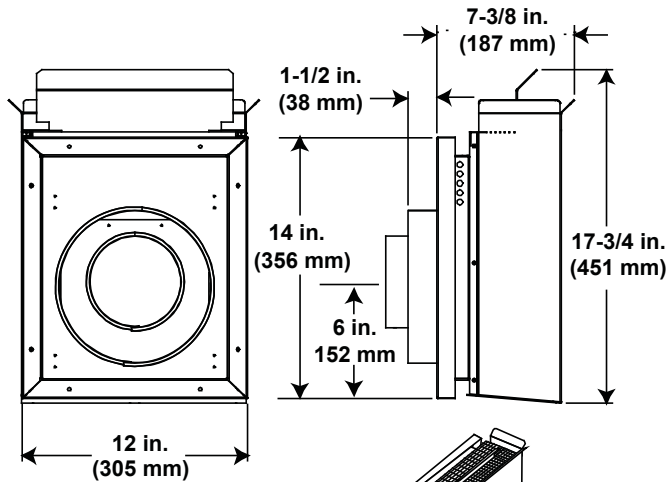

DVP-TB1
Basement Vent Cap

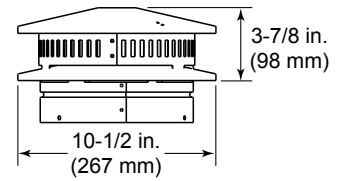
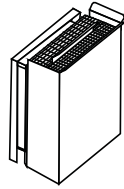

DVP-TV
Vertical Termination Cap

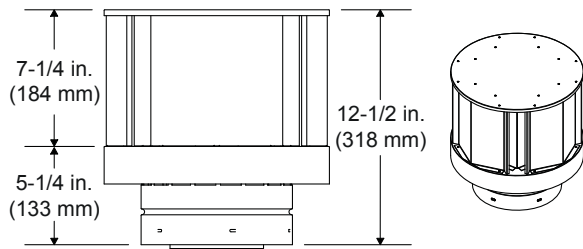

DVP-TVHW
Vertical Termination Cap (High wind)

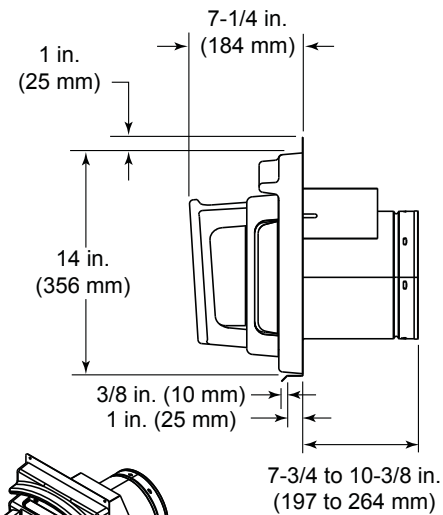

DVP-FBHT
Fire Brick Termination Cap

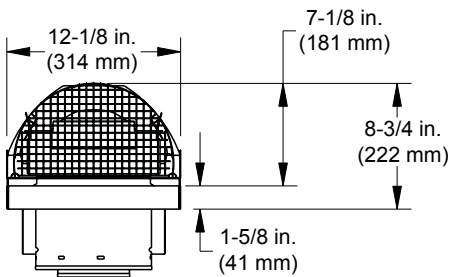
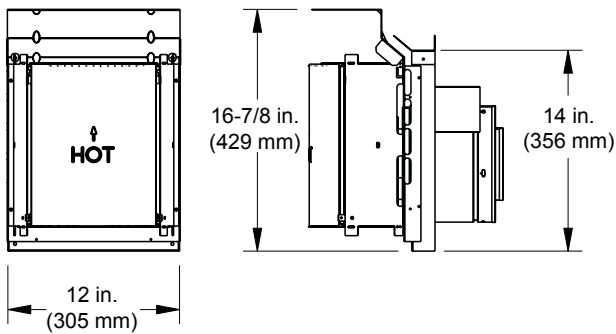

DVP-HPC
High Performance Cap

Figure 17.4 DVP Vent Components

B. Vent Components Diagrams (continued)

Note: Heat shields MUST overlap by a minimum of 1-1/2 in. (38 mm). **The heat shield is designed to be used on a wall 4 in. to 7-1/4 in. (102 mm to 184 mm) thick.** If wall thickness is less than 4 in. (102 mm) the existing heat shields must be field trimmed. If wall thickness is greater than 7-1/4 in. (184 mm) a DVP-HSM-B will be required.

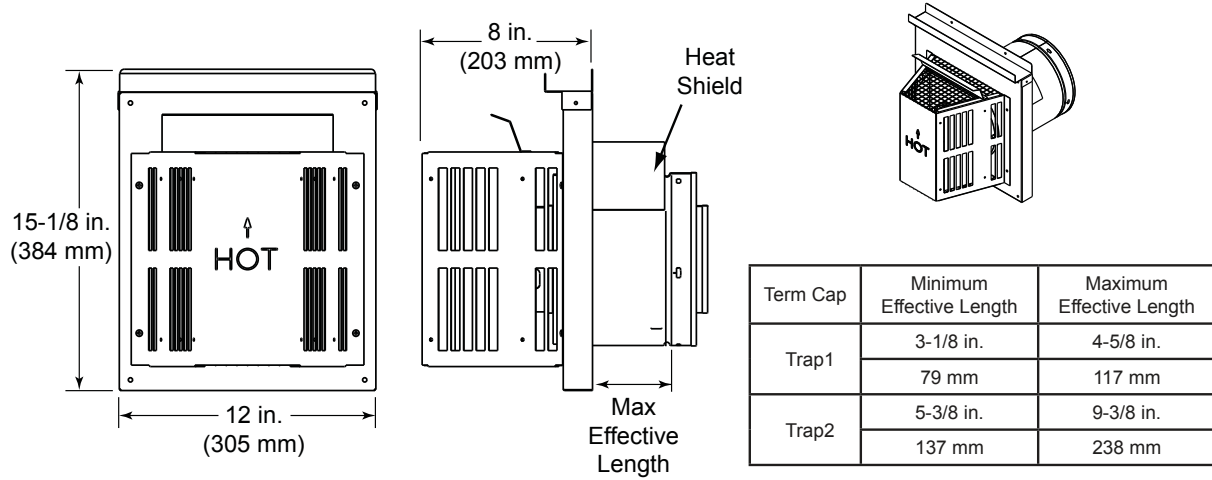

DVP-TRAP Horizontal Termination Cap

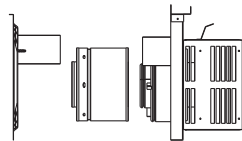

DVP-TRAP1

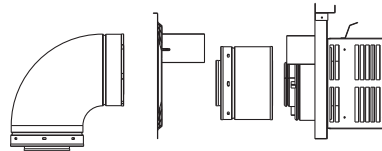

DVP-TRAPK1

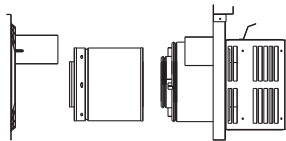

DVP-TRAP2

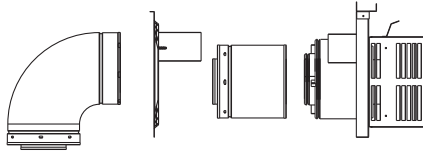

DVP-TRAPK2

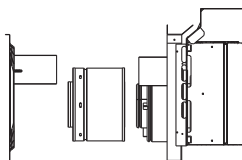

DVP-HPC1

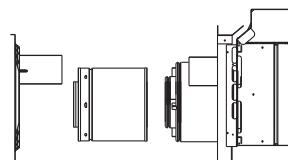

DVP-HPC2

Figure 17.5 DVP Vent Components

B. Vent Components Diagrams (continued)

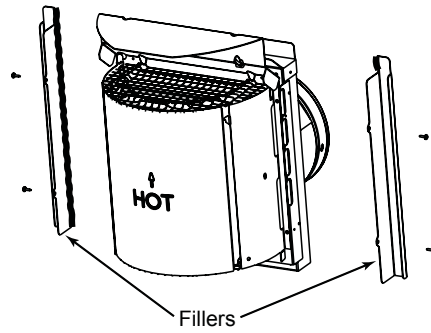

DVP-TRAP to DVP-HPC Side Filler Kit

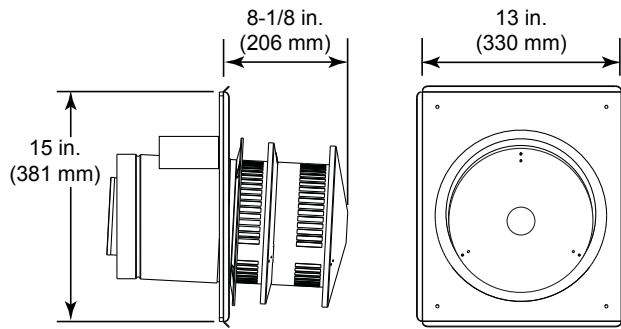

DVP-HRC-SS

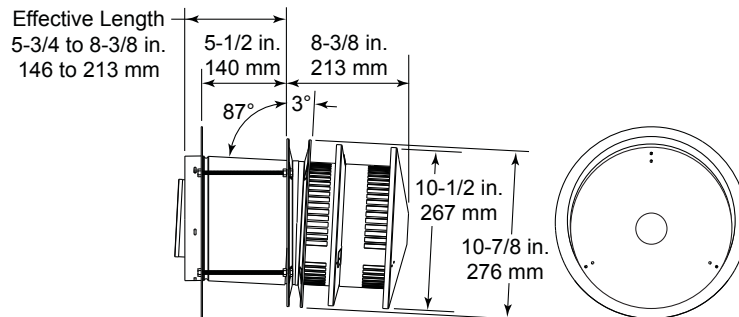

DVP-HRC-ZC-SS

Figure 17.6 DVP Vent Components

B. Vent Components Diagrams (continued)

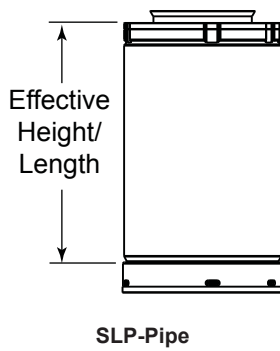
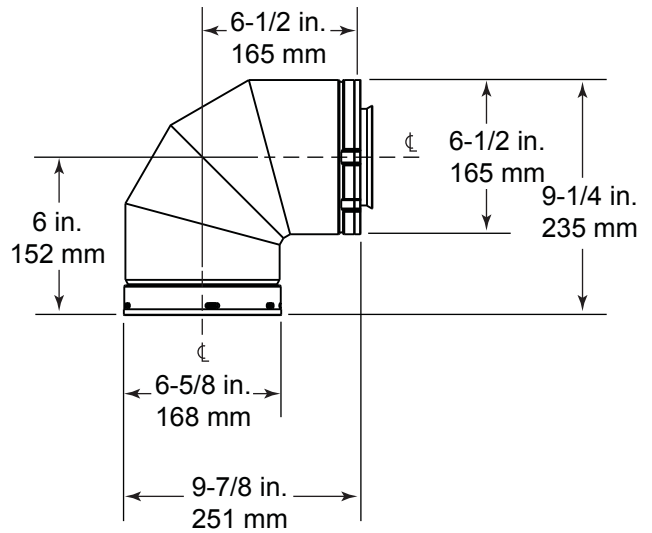
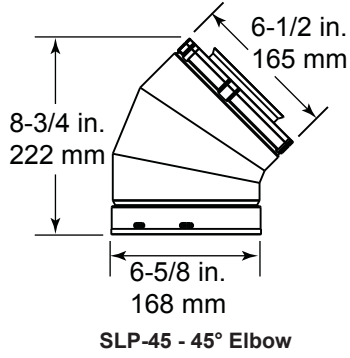

Effective Height/Length		
Pipe	inches	mm
SLP4	4	102
SLP6	6	152
SLP12	12	305
SLP24	24	610
SLP36	36	914
SLP48	48	1219
SLP6A	2 - 6	51 - 152
SLP12A	2 - 12	51 - 305

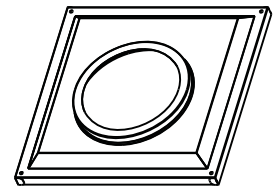
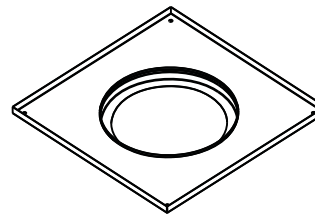
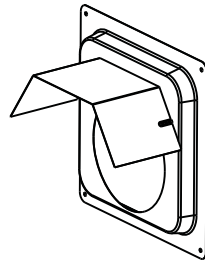
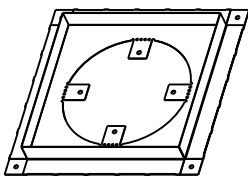
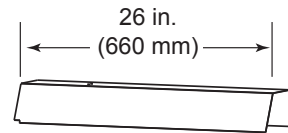
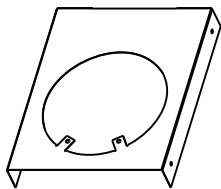
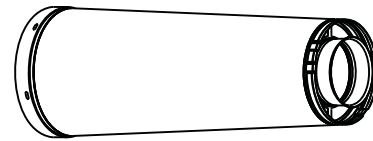
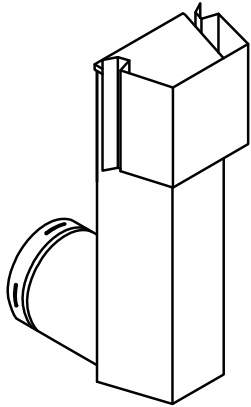
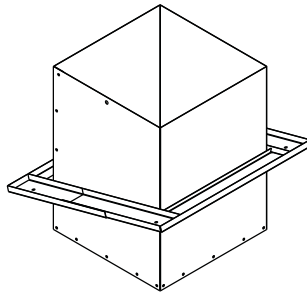

Figure 17.7 SLP Series Vent Components

B. Vent Components Diagrams (continued)



SLK-SNKD
Snorkel
Termination Cap



SLP-CCS-BK
Cathedral Ceiling Sup-
port Box-Black

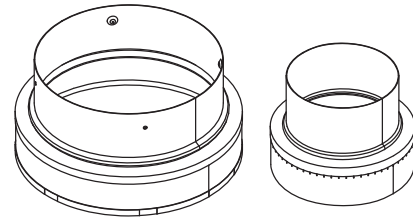

SL-2DVP
Adapter

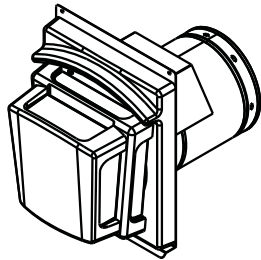

DVP-FBHT
Firebrick Termination Cap
(This termination cap requires an SL-2DVP adapter when used with SLP Pipe)

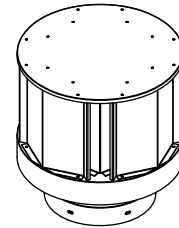

SLP-TVHW
Vertical
Termination Cap

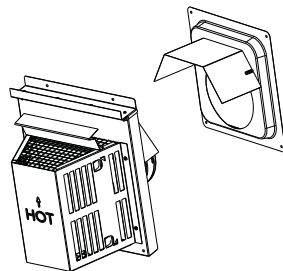

SLP-TRAP1
Horizontal
Termination Cap

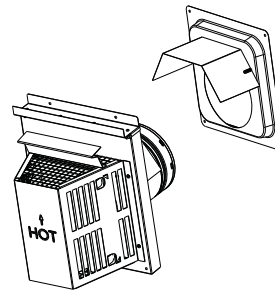

SLP-TRAP2
Horizontal
Termination Cap

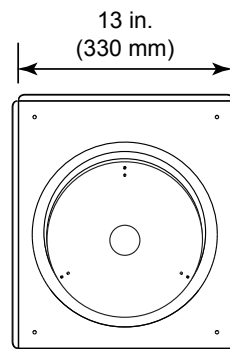
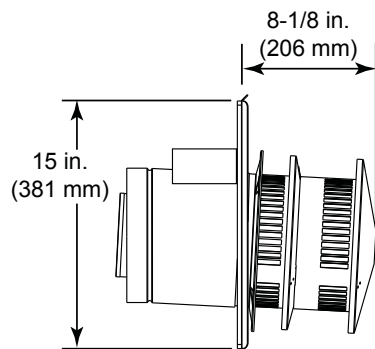

SLP-HRC-SS

Figure 17.8 SLP Series Vent Components

B. Vent Components Diagrams (continued)

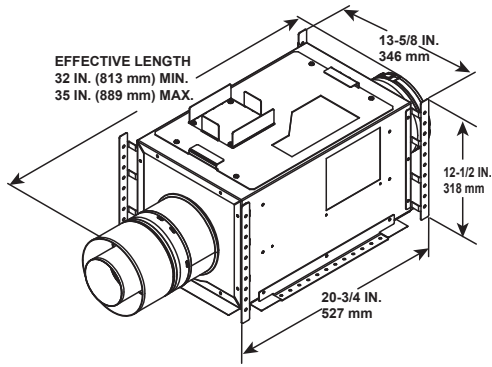

PVI-SLP
Power Vent Inline

Optional Wire Harness	
DESCRIPTION	PART NUMBER
10 ft. PV Wire Harness	PVI-WH10
20 ft. PV Wire Harness	PVI-WH20
40 ft. PV Wire Harness	PVI-WH40
60 ft. PV Wire Harness	PVI-WH60
80 ft. PV Wire Harness	PVI-WH80
100 ft. PV Wire Harness	PVI-WH100

Note: Wire harnesses required to power the PVI-SLP connect to the appliance and are ordered separately from PVI-SLP. Contact your dealer to order.

Note: Use only approved termination caps with the PVI-SLP. See instructions included with PVI-SLP kit.

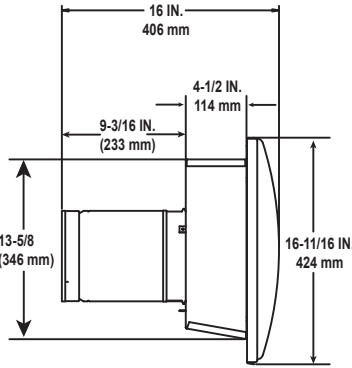
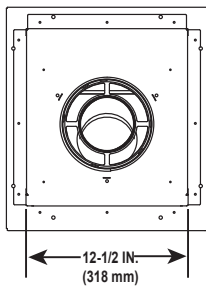

SLP-LPC
SLP Low Profile Cap

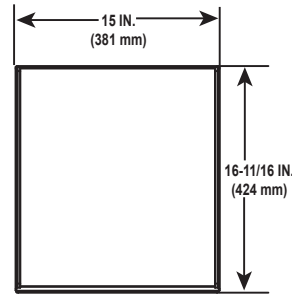

Note: Heat shields **MUST** overlap by a minimum of 1-1/2 in. (38 mm). **The heat shield is designed to be used on a wall 4 in. to 7-1/4 in. (102 mm to 184 mm) thick.** If wall thickness is less than 4 in. (102 mm) the existing heat shields must be field trimmed. If wall thickness is greater than 7-1/4 in. (184 mm) a DVP-HSM-B will be required.

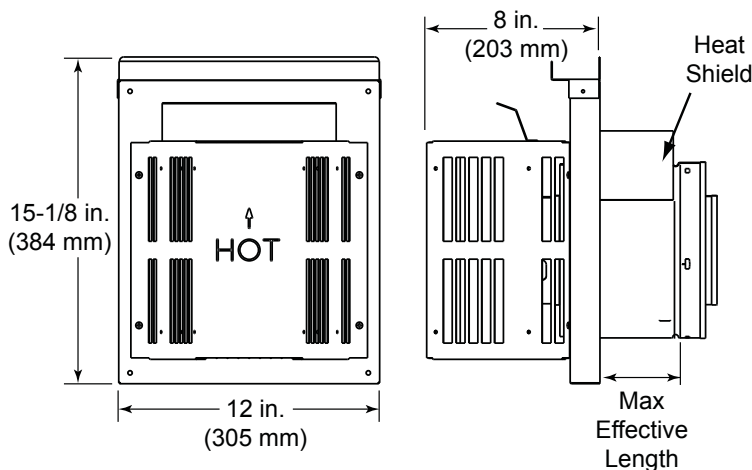

SLP-TRAP
Horizontal Termination Cap

Term Cap	Minimum Effective Length	Maximum Effective Length
Trap1	3 1/8 in.	4 3/4 in.
	79 mm	121 mm
Trap2	5 1/4 in.	9 1/4 in.
	133 mm	235 mm

Figure 17.9 Vent Components

B. Vent Components Diagrams (continued)

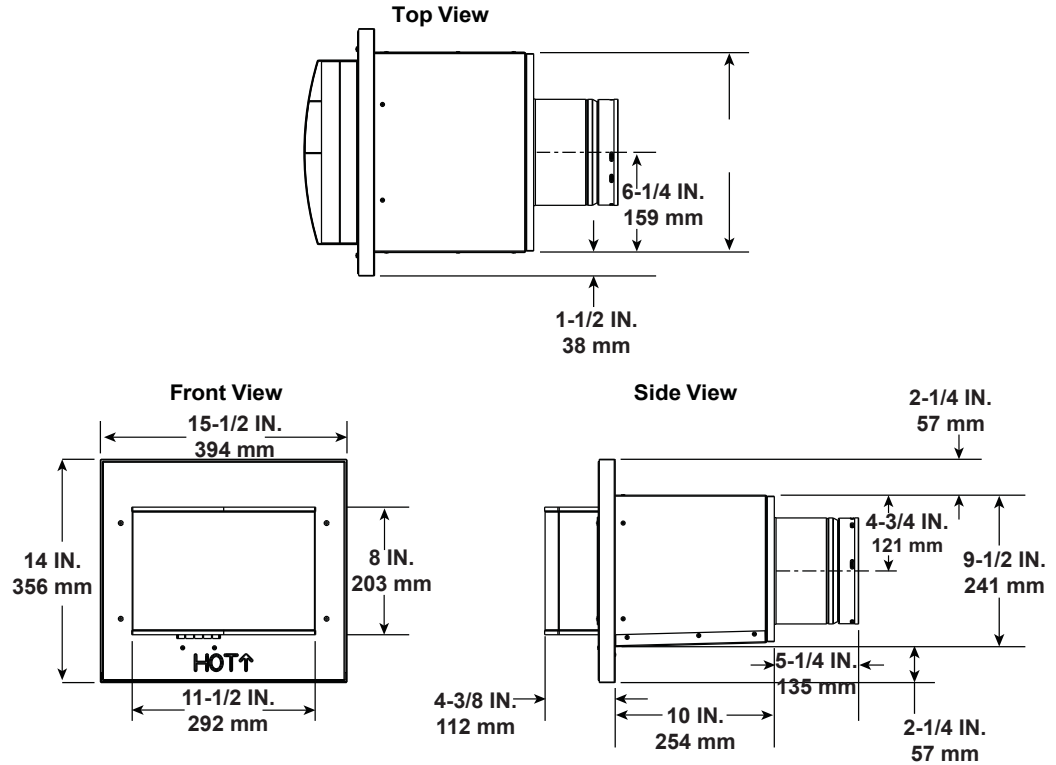

Required Wire Harness	
DESCRIPTION	PART NUMBER
10 FT PV Wire Harness	PVI-WH10
20 FT PV Wire Harness	PVI-WH20
40 FT PV Wire Harness	PVI-WH40
60 FT PV Wire Harness	PVI-WH60
80 FT PV Wire Harness	PVI-WH80
100 FT PV Wire Harness	PVI-WH100

Note: Wire harnesses required to power the PVLP-SLP connect to the appliance and are ordered separately from PVLP-SLP. Contact your dealer to order.

Note: The PVLP-SLP requires a PVLP-CK be installed on this appliance. The PVLP-CK is ordered separately from the PVLP-SLP. Contact your dealer to order.

Note: A PVLP-HS heat shield is available and sold separately. Use if the PVLP-SLP is installed in a high traffic area.

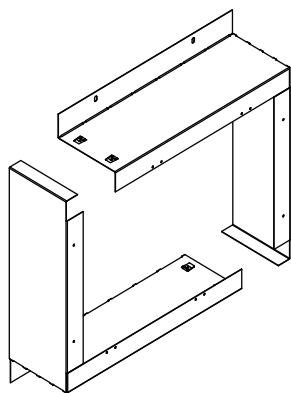

**PVLP-BEK
Brick Kit**

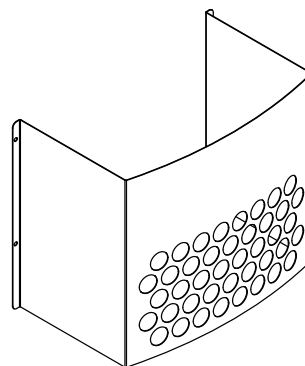

**PVLP-HS
Heat Shield**

Figure 17.10 PVLP-SLP Vent Components

D. Optional Components

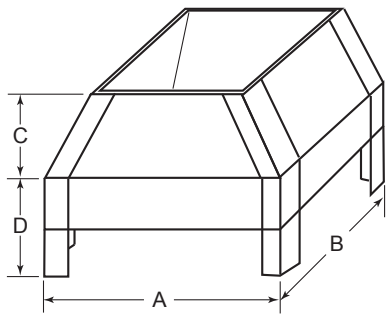

LDS33/LDS46 Decorative Shroud

Catalog #	A		B		C		D	
	<i>in.</i>	<i>mm</i>	<i>in.</i>	<i>mm</i>	<i>in.</i>	<i>mm</i>	<i>in.</i>	<i>mm</i>
LDS33	36	914	36	914	8.5	216	11	279
LDS46	48	1219	72	1829	8.5	216	11	279

LDSCP-M Shroud Leg Multipack
(not shown)

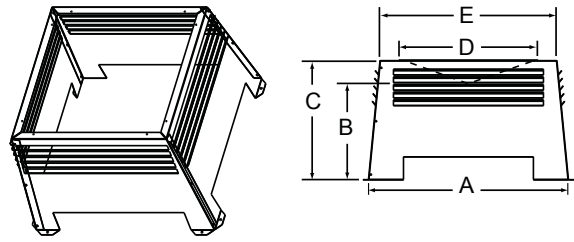

LDS-BV Decorative Shroud

Catalog #		A	B	C	E	E
LDS-BV	<i>in.</i>	26	12.5	15.5	22	23
	<i>mm</i>	660	318	394	533	584

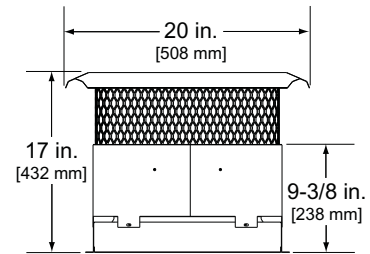

TCG375 Terra Cotta Cap

