

Model(s):  
QFP44

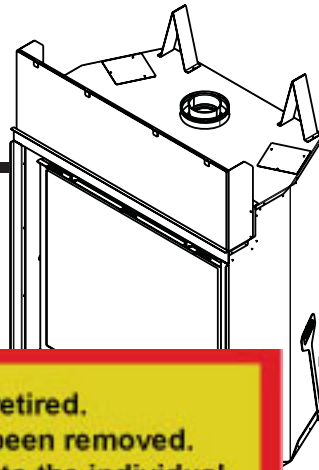

GAS-FIRED



This appliance has been retired.  
Service parts pages within have been removed.  
For replacement parts, please refer to the individual  
service parts list located on the brand websites.



### DO NOT DISCARD THIS MANUAL

- Important operating and maintenance instructions included.
- Read, understand and follow these instructions for safe installation and operation.
- Leave this manual with party responsible for use and operation.



### ⚠ WARNING



If the information in these instructions is not followed exactly, a fire may result causing property damage, personal injury, or death.

- Do not store or use gasoline or other flammable vapors and liquids in the vicinity of this or any other appliance.
- **What to do if you smell gas:**
  - Do not try to light any appliance.
  - Do not touch any electrical switch. Do not use any phone in your building.
  - Immediately call your gas supplier from a neighbor's phone. Follow the gas supplier's instructions.
  - If you cannot reach your gas supplier, call the fire department.
- Installation and service must be performed by a qualified installer, service agency, or the gas supplier.

### ⚠ WARNING



#### HOT SURFACES!

Glass and other surfaces are hot during operation and cool down.

#### Hot glass will cause burns.

- Do not touch glass until it is cooled
  - NEVER allow children to touch glass
  - Keep children away
  - CAREFULLY SUPERVISE children in same room as appliance.
  - Alert children and adults to hazards of high temperatures.
- High temperatures may ignite clothing or other flammable materials.**
- Keep clothing, furniture, draperies and other combustibles away.

***This appliance requires installation of a decorative front with an integral barrier to prevent direct contact with the fixed glass panel. Do NOT operate the appliance with the barrier removed.***

Contact your dealer or Hearth & Home Technologies if the barrier is not present or help is needed to properly install one.

In the Commonwealth of Massachusetts installation must be performed by a licensed plumber or gas fitter. See Table of Contents for location of additional Commonwealth of Massachusetts requirements.



Installation and service of this appliance should be performed by qualified personnel. Hearth & Home Technologies suggests NFI certified or factory-trained professionals, or technicians supervised by an NFI certified professional.

Read this manual before installing or operating this appliance.  
Please retain this owner's manual for future reference.

### A. Congratulations

Congratulations on selecting a Quadra-Fire gas fireplace, an elegant and clean alternative to wood burning fireplaces. The Quadra-Fire gas fireplace you have selected is designed to provide the utmost in safety, reliability, and efficiency.

As the owner of a new fireplace, you'll want to read and carefully follow all of the instructions contained in this owner's manual. Pay special attention to all cautions and warnings.

This owner's manual should be retained for future reference. We suggest that you keep it with your other important documents and product manuals.

The information contained in this owner's manual, unless noted otherwise, applies to all models and gas control systems.

Your new Quadra-Fire gas fireplace will give you years of durable use and trouble-free enjoyment. Welcome to the Quadra-Fire family of fireplace products!

<b>Homeowner Reference Information</b>	<i>We recommend that you record the following pertinent information about your fireplace.</i>
Model Name: _____	Date purchased/installed: _____
Serial Number: _____	Location on fireplace: _____
Dealership purchased from: _____	Dealer Phone: _____
Notes: _____	
_____	

### Listing Label Information/Location

The model information regarding your specific fireplace can be found on the rating plate usually located in the control area of the fireplace.

**QUADRA-FIRE** Quadra-Fire, a brand of Hearth & Home Technologies Inc.  
7571 215th Street West, Lakeville, MN 55044

**Not for use with solid fuel.**  
*(Ne doit pas être utilisé avec un combustible solide).*

Type of Gas (Sorte De Gaz): **NATURAL GAS**

**ANSI Z21XX-XXXX · CSA 2.XX-MXX · UL307B**

**Minimum Permissible Gas Supply for Purposes of Input Adjustment.**

Approved Minimum (De Gaz) Acceptable	0.0 in w.c.	(Po. Col. d'eau)
Maximum Pressure (Pression)	0.0 in w.c.	(Po. Col. d'eau)
Maximum Manifold Pressure (Pression)	0.0 in w.c.	(Po. Col. d'eau)
Minimum Manifold Pressure (Pression)	0.0 in w.c.	(Po. Col. d'eau)

Total Electrical Requirements: 000Vac, 00Hz., less than 00 Amperes

**GAS-FIRED**



**LISTED**

ALTITUDE:	0-0000 FT.	IN CANADA	0000-0000FT.
MAX. INPUT BTUH:	00,000		00,000
MIN. INPUT BTUH:	00,000		00,000
ORIFICE SIZE:	#XXXXX		#XXXXX

Model: (Modele):	XXXXXXXX
Serial (Serie):	XXXXXXXX

Type of Gas →

Gas and Electric Information →

Model Number →

Serial Number →

## ▲ Safety Alert Key:

- **DANGER!** Indicates a hazardous situation which, if not avoided will result in death or serious injury.
- **WARNING!** Indicates a hazardous situation which, if not avoided could result in death or serious injury.
- **CAUTION!** Indicates a hazardous situation which, if not avoided, could result in minor or moderate injury.
- **NOTICE:** Used to address practices not related to personal injury.

## Table of Contents

A. Congratulations	2
B. Limited Lifetime Warranty	5
<b>1 Listing and Code Approvals</b>	
A. Appliance Certification	7
B. Ceramic Glass Specifications	7
C. BTU Specifications	7
D. High Altitude Installations	7
E. Non-Combustible Materials Specification	7
F. Combustible Materials Specification	7
G. Electrical Codes	7
H. Requirements for the Commonwealth of Massachusetts	8

## User Guide

### 2 Operating Instructions

A. Gas Fireplace Safety	9
B. Your Fireplace	9
C. Clear Space	10
D. Decorative Doors and Fronts	10
E. Fixed Glass Assembly	10
F. Dashboard Control	10
G. Remote Operation	11
H. Before Lighting Fireplace	16
I. Lighting Instructions (SP)	17
J. After Fireplace is Lit	18
K. Frequently Asked Questions	18

### 3 Maintenance and Service

→ A. Maintenance Tasks-Homeowner	19
B. Maintenance Tasks-Qualified Service Technician	20

## Installer Guide

### 4 Getting Started

A. Typical Appliance System	21
B. Design and Installation Considerations	22
C. Tools and Supplies Needed	22
D. Inspect Appliance and Components	22

### 5 Framing and Clearances

A. Select Appliance Location	23
B. Construct the Appliance Chase	24
C. Clearances	24
D. Mantel and Wall Projections	25

### 6 Termination Locations

A. Vent Termination Minimum Clearances	26
--	----

### 7 Vent Information and Diagrams

A. Approved Pipe	28
B. Vent Table Key	28
C. Use of Elbows	28
D. Measuring Standards	28
E. Vent Diagrams	29

### 8 Vent Clearances and Framing

A. Pipe Clearances to Combustibles	33
B. Wall Penetration Framing	33
C. Install the Ceiling Firestop	34
D. Install Attic Insulation Shield	35

### 9 Appliance Preparation

A. Secure and Level the Appliance	36
-----------------------------------	----

### 10 Install Vent Pipe

A. Assemble Vent Sections	37
B. Assemble Slip Sections	38
C. Secure the Vent Sections	39
D. Disassemble Vent Sections	39
E. Install Metal Roof Flashing	40
F. Assemble and Install Storm Collar	41
G. Install Vertical Termination Cap	42
H. Heat Shield Requirements for Horizontal Termination	42
I. Install Horizontal Termination Cap	43

### 11 Shrouds

A. HHT Shrouds	44
B. Field Constructed Shrouds	44

### 12 Gas Information

A. Fuel Conversion	46 ←
B. Gas Pressure	48
C. Gas Connection	48
D. High Altitude Installations	48

### 13 Electrical Information

A. Wiring Requirements	49
B. Standing Pilot Ignition System Wiring	49
C. Optional Accessories Requirements	49
D. Electrical Service and Repair	50
E. Junction Box Installation	50

### 14 Finishing

A. Mantel and Wall Projections	51
B. Facing Material	52
C. Facing Template Removal	52
D. Mantel	52

## 15 Appliance Setup

A. Remove Glass Assembly	53
B. Clean the Appliance	53
C. Install the Refractory	53
D. Adjust the Air Shutter	54
E. Adjust the Vertical Baffle	55
F. Install Logs, Ember Bed & Rockwool	55
G. Install Andirons	57
H. Place Lava Rock and Vermiculite	57
I. Reinstall Glass	57

## 16 Troubleshooting

A. Standing Pilot Ignition System	58
-----------------------------------	----

## 17 Reference Materials

A. Appliance Dimension Diagram	60
B. Vent Components Diagrams	61
→ C. Service Parts	65
D. Optional Components	69
E. Contact Information	70

→ = Contains updated information.

## B. Limited Lifetime Warranty

### Hearth & Home Technologies Inc. LIMITED LIFETIME WARRANTY

Hearth & Home Technologies Inc., on behalf of its hearth brands ("HHT"), extends the following warranty for HHT gas, wood, pellet, coal and electric hearth appliances that are purchased from an HHT authorized dealer.

#### **WARRANTY COVERAGE:**

HHT warrants to the original owner of the HHT appliance at the site of installation, and to any transferee taking ownership of the appliance at the site of installation within two years following the date of original purchase, that the HHT appliance will be free from defects in materials and workmanship at the time of manufacture. After installation, if covered components manufactured by HHT are found to be defective in materials or workmanship during the applicable warranty period, HHT will, at its option, repair or replace the covered components. HHT, at its own discretion, may fully discharge all of its obligations under such warranties by replacing the product itself or refunding the verified purchase price of the product itself. The maximum amount recoverable under this warranty is limited to the purchase price of the product. This warranty is subject to conditions, exclusions and limitations as described below.

#### **WARRANTY PERIOD:**

Warranty coverage begins on the date of original purchase. In the case of new home construction, warranty coverage begins on the date of first occupancy of the dwelling or six months after the sale of the product by an independent, authorized HHT dealer/ distributor, whichever occurs earlier. The warranty shall commence no later than 24 months following the date of product shipment from HHT, regardless of the installation or occupancy date. The warranty period for parts and labor for covered components is produced in the following table.

The term "Limited Lifetime" in the table below is defined as: 20 years from the beginning date of warranty coverage for gas appliances, and 10 years from the beginning date of warranty coverage for wood, pellet, and coal appliances. These time periods reflect the minimum expected useful lives of the designated components under normal operating conditions.

Warranty Period		HHT Manufactured Appliances and Venting							Components Covered
Parts	Labor	Gas	Wood	Pellet	EPA Wood	Coal	Electric	Venting	
1 Year		X	X	X	X	X	X	X	All parts and material except as covered by Conditions, Exclusions, and Limitations listed
2 years				X	X	X			Igniters, electronic components, and glass
		X	X	X	X	X			Factory-installed blowers
			X						Molded refractory panels
3 years				X					Firepots and burnpots
5 years	1 year			X	X				Castings and baffles
7 years	3 years		X	X	X				Manifold tubes, HHT chimney and termination
10 years	1 year	X							Burners, logs and refractory
Limited Lifetime	3 years	X	X	X	X	X			Firebox and heat exchanger
90 Days		X	X	X	X	X	X	X	All replacement parts beyond warranty period

See conditions, exclusions, and limitations on next page.

## **B. Limited Lifetime Warranty (*continued*)**

### **WARRANTY CONDITIONS:**

- This warranty only covers HHT appliances that are purchased through an HHT authorized dealer or distributor. A list of HHT authorized dealers is available on the HHT branded websites.
- This warranty is only valid while the HHT appliance remains at the site of original installation.
- Contact your installing dealer for warranty service. If the installing dealer is unable to provide necessary parts, contact the nearest HHT authorized dealer or supplier. Additional service fees may apply if you are seeking warranty service from a dealer other than the dealer from whom you originally purchased the product.
- Check with your dealer in advance for any costs to you when arranging a warranty call. Travel and shipping charges for parts are not covered by this warranty.

### **WARRANTY EXCLUSIONS:**

This warranty does not cover the following:

- Changes in surface finishes as a result of normal use. As a heating appliance, some changes in color of interior and exterior surface finishes may occur. This is not a flaw and is not covered under warranty.
- Damage to printed, plated, or enameled surfaces caused by fingerprints, accidents, misuse, scratches, melted items, or other external sources and residues left on the plated surfaces from the use of abrasive cleaners or polishes.
- Repair or replacement of parts that are subject to normal wear and tear during the warranty period. These parts include: paint, wood, pellet and coal gaskets, firebricks, grates, flame guides, light bulbs, batteries and the discoloration of glass.
- Minor expansion, contraction, or movement of certain parts causing noise. These conditions are normal and complaints related to this noise are not covered by this warranty.
- Damages resulting from: (1) failure to install, operate, or maintain the appliance in accordance with the installation instructions, operating instructions, and listing agent identification label furnished with the appliance; (2) failure to install the appliance in accordance with local building codes; (3) shipping or improper handling; (4) improper operation, abuse, misuse, continued operation with damaged, corroded or failed components, accident, or improperly/incorrectly performed repairs; (5) environmental conditions, inadequate ventilation, negative pressure, or drafting caused by tightly sealed constructions, insufficient make-up air supply, or handling devices such as exhaust fans or forced air furnaces or other such causes; (6) use of fuels other than those specified in the operating instructions; (7) installation or use of components not supplied with the appliance or any other components not expressly authorized and approved by HHT; (8) modification of the appliance not expressly authorized and approved by HHT in writing; and/or (9) interruptions or fluctuations of electrical power supply to the appliance.
- Non-HHT venting components, hearth components or other accessories used in conjunction with the appliance.
- Any part of a pre-existing fireplace system in which an insert or a decorative gas appliance is installed.
- HHT's obligation under this warranty does not extend to the appliance's capability to heat the desired space. Information is provided to assist the consumer and the dealer in selecting the proper appliance for the application. Consideration must be given to appliance location and configuration, environmental conditions, insulation and air tightness of the structure.

### **This warranty is void if:**

- The appliance has been over-fired or operated in atmospheres contaminated by chlorine, fluorine, or other damaging chemicals. Over-firing can be identified by, but not limited to, warped plates or tubes, rust colored cast iron, bubbling, cracking and discoloration of steel or enamel finishes.
- The appliance is subjected to prolonged periods of dampness or condensation.
- There is any damage to the appliance or other components due to water or weather damage which is the result of, but not limited to, improper chimney or venting installation.

### **LIMITATIONS OF LIABILITY:**

- The owner's exclusive remedy and HHT's sole obligation under this warranty, under any other warranty, express or implied, or in contract, tort or otherwise, shall be limited to replacement, repair, or refund, as specified above. In no event will HHT be liable for any incidental or consequential damages caused by defects in the appliance. Some states do not allow exclusions or limitation of incidental or consequential damages, so these limitations may not apply to you. This warranty gives you specific rights; you may also have other rights, which vary from state to state. **EXCEPT TO THE EXTENT PROVIDED BY LAW, HHT MAKES NO EXPRESS WARRANTIES OTHER THAN THE WARRANTY SPECIFIED HEREIN. THE DURATION OF ANY IMPLIED WARRANTY IS LIMITED TO DURATION OF THE EXPRESSED WARRANTY SPECIFIED ABOVE.**

# 1 Listing and Code Approvals

## A. Appliance Certification

**MODELS:** QFP44

**LABORATORY:** Underwriters Laboratories, Inc. (UL)

**TYPE:** Vented Gas Fireplace Heater

**STANDARD:** ANSI Z21.88b-2008 • CSA 2.33b-2008

**NOTICE:** This installation must conform with local codes or, in the absence of local codes, with the National Fuel Gas Code, ANSI Z223.1/NFPA 54, or the Natural Gas and Propane Installation Code, CSA B149.1.

- A manufactured home (USA only) or mobile home OEM installation must conform with the (U.S.) *Manufactured Home Construction and Safety Standard, Title 24 CFR, Part 3280* or, when such a standard is not applicable, the *Standard for Fire Safety Criteria for Manufactured Home Installation Sites and Communities, ANSI/NFPA 501A*, in the United States, or the *Mobile Homes Standard, CAN/CSA Z240 MH Series* in Canada.
- This appliance complies with the installation requirements for HUD.

**NOT INTENDED FOR USE AS A PRIMARY HEAT SOURCE.**

This appliance is tested and approved as either supplemental room heat or as a decorative appliance. It should not be factored as primary heat in residential heating calculations.

## B. Ceramic Glass Specifications

This appliance is equipped with 5 mm ceramic glass. Replace glass with 5 mm ceramic glass. Please contact your dealer for replacement glass.

## C. BTU Specifications

QFP44 Series	IPI
Max/Min Input Rate (NG) Both Burners	70,000 / 47,000
Max/Min Input Rate (NG) Front Burner	19,000 / 13,500
Max/Min Input Rate (LP) Both Burners	67,000 / 51,000
Max/Min Input Rate (LP) Front Burner	21,000 / 14,500
Orifice Size (NG) Front	#46/.084 in./2.13 mm
Orifice Size (NG) Rear	#18/.169 in./4.29 mm
Orifice Size (LP) Front	#56/.046 in./1.17 mm
Orifice Size (LP) Rear	#46/.084 in./2.13 mm

## D. High Altitude Installations

**NOTICE:** If the heating value of the gas has been reduced, these rules do not apply. Check with your local gas utility or authorities having jurisdiction.

When installing above 2000 feet elevation:

- In the USA: Reduce input rate 4% for each 1000 feet above 2000 feet.
- In CANADA: Reduce input rate 10% for elevations between 2000 feet and 4500 feet. Above 4500 feet, consult local gas utility.

Check with your local gas utility to determine proper orifice size.

## E. Non-Combustible Materials Specification

Material which will not ignite and burn. Such materials are those consisting entirely of steel, iron, brick, tile, concrete, slate, glass or plasters, or any combination thereof.

Materials that are reported as passing **ASTM E 136, Standard Test Method for Behavior of Materials in a Vertical Tube Furnace at 750 °C** and **UL763** shall be considered non-combustible materials.

## F. Combustible Materials Specification

Materials made of or surfaced with wood, compressed paper, plant fibers, plastics, or other material that can ignite and burn, whether flame proofed or not, or plastered or unplastered shall be considered combustible materials.

## G. Electrical Codes

**NOTICE:** This appliance must be electrically wired and grounded in accordance with local codes or, in the absence of local codes, with **National Electric Code ANSI/NFPA 70-latest edition** or the **Canadian Electric Code CSA C22.1**.

- A 110-120 VAC circuit for this product must be protected with ground-fault circuit-interrupter protection, in compliance with the applicable electrical codes, when it is installed in locations such as in bathrooms or near sinks.

**Note:** The following requirements reference various Massachusetts and national codes not contained in this document.

## H. Requirements for the Commonwealth of Massachusetts

For all side wall horizontally vented gas fueled equipment installed in every dwelling, building or structure used in whole or in part for residential purposes, including those owned or operated by the Commonwealth and where the side wall exhaust vent termination is less than seven (7) feet above finished grade in the area of the venting, including but not limited to decks and porches, the following requirements shall be satisfied:

### Installation of Carbon Monoxide Detectors

At the time of installation of the side wall horizontal vented gas fueled equipment, the installing plumber or gas fitter shall observe that a hard wired carbon monoxide detector with an alarm and battery back-up is installed on the floor level where the gas equipment is to be installed. In addition, the installing plumber or gas fitter shall observe that a battery operated or hard wired carbon monoxide detector with an alarm is installed on each additional level of the dwelling, building or structure served by the side wall horizontal vented gas fueled equipment. It shall be the responsibility of the property owner to secure the services of qualified licensed professionals for the installation of hard wired carbon monoxide detectors.

In the event that the side wall horizontally vented gas fueled equipment is installed in a crawl space or an attic, the hard wired carbon monoxide detector with alarm and battery back-up may be installed on the next adjacent floor level.

In the event that the requirements of this subdivision can not be met at the time of completion of installation, the owner shall have a period of thirty (30) days to comply with the above requirements; provided, however, that during said thirty (30) day period, a battery operated carbon monoxide detector with an alarm shall be installed.

### Approved Carbon Monoxide Detectors

Each carbon monoxide detector as required in accordance with the above provisions shall comply with NFPA 720 and be ANSI/UL 2034 listed and IAS certified.

### Signage

A metal or plastic identification plate shall be permanently mounted to the exterior of the building at a minimum height of eight (8) feet above grade directly in line with the exhaust vent terminal for the horizontally vented gas fueled heating appliance or equipment. The sign shall read, in print size no less than one-half (1/2) in. in size, **“GAS VENT DIRECTLY BELOW. KEEP CLEAR OF ALL OBSTRUCTIONS”**.

## Inspection

The state or local gas inspector of the side wall horizontally vented gas fueled equipment shall not approve the installation unless, upon inspection, the inspector observes carbon monoxide detectors and signage installed in accordance with the provisions of 248 CMR 5.08(2)(a)1 through 4.

## Exemptions

The following equipment is exempt from 248 CMR 5.08(2)(a)1 through 4:

- The equipment listed in Chapter 10 entitled “Equipment Not Required To Be Vented” in the most current edition of NFPA 54 as adopted by the Board; and
- Product Approved side wall horizontally vented gas fueled equipment installed in a room or structure separate from the dwelling, building or structure used in whole or in part for residential purposes.

## MANUFACTURER REQUIREMENTS

### Gas Equipment Venting System Provided

When the manufacturer of Product Approved side wall horizontally vented gas equipment provides a venting system design or venting system components with the equipment, the instructions provided by the manufacturer for installation of the equipment and the venting system shall include:

- Detailed instructions for the installation of the venting system design or the venting system components; and
- A complete parts list for the venting system design or venting system.

### Gas Equipment Venting System **NOT** Provided

When the manufacturer of a Product Approved side wall horizontally vented gas fueled equipment does not provide the parts for venting the flue gases, but identifies “special venting systems”, the following requirements shall be satisfied by the manufacturer:

- The referenced “special venting system” instructions shall be included with the appliance or equipment installation instructions; and
- The “special venting systems” shall be Product Approved by the Board, and the instructions for that system shall include a parts list and detailed installation instructions.

A copy of all installation instructions for all Product Approved side wall horizontally vented gas fueled equipment, all venting instructions, all parts lists for venting instructions, and/or all venting design instructions shall remain with the appliance or equipment at the completion of the installation.

**See Gas Connection section for additional Commonwealth of Massachusetts requirements.**



# User Guide

## 2 Operating Instructions

### A. Gas Fireplace Safety

#### **⚠ WARNING**



#### **HOT SURFACES!**

Glass and other surfaces are hot during operation and cool down.

#### **Hot glass will cause burns.**

- Do not touch glass until it is cooled
- NEVER allow children to touch glass
- Keep children away
- CAREFULLY SUPERVISE children in

same room as appliance.

- Alert children and adults to hazards of high temperatures.

#### **High temperatures may ignite clothing or other flammable materials.**

- Keep clothing, furniture, draperies and other combustibles away.

***This appliance requires the installation of a decorative front with an integral barrier to prevent direct contact with the fixed glass panel. Do NOT operate the appliance with the barrier removed.***

Contact your dealer or Hearth & Home Technologies if the barrier is not present or help is needed to properly install one.

If you expect that small children or vulnerable adults may come into contact with this fireplace, the following precautions are recommended:

- Install a physical barrier such as:
  - A decorative firescreen.
  - Adjustable safety gate.
- Install a switch lock or a wall/remote control with child protection lockout feature.
- Keep remote controls out of reach of children.
- Never leave children alone near a hot fireplace, whether operating or cooling down.
- Teach children to NEVER touch the fireplace.
- Consider not using the fireplace when children will be present.

Contact your dealer for more information, or visit: [www.hpba.org/safety-information](http://www.hpba.org/safety-information).

To prevent unintended operation when not using your fireplace for an extended period of time (summer months, vacations, trips, etc):

- Remove batteries from remote controls.
- Turn off wall controls.
- Unplug 3 volt adapter plug and remove batteries on IPI models.
- Turn off gas controls valve on standing pilot models.

When lighting the pilot light on fireplaces with a standing pilot, remove the fixed glass assembly so you can detect presence of residual gas build-up. See Standing Pilot Lighting instructions and Maintenance Tasks.

### B. Your Fireplace

***WARNING! DO NOT operate fireplace before reading and understanding operating instructions. Failure to operate fireplace according to operating instructions could cause fire or injury.***

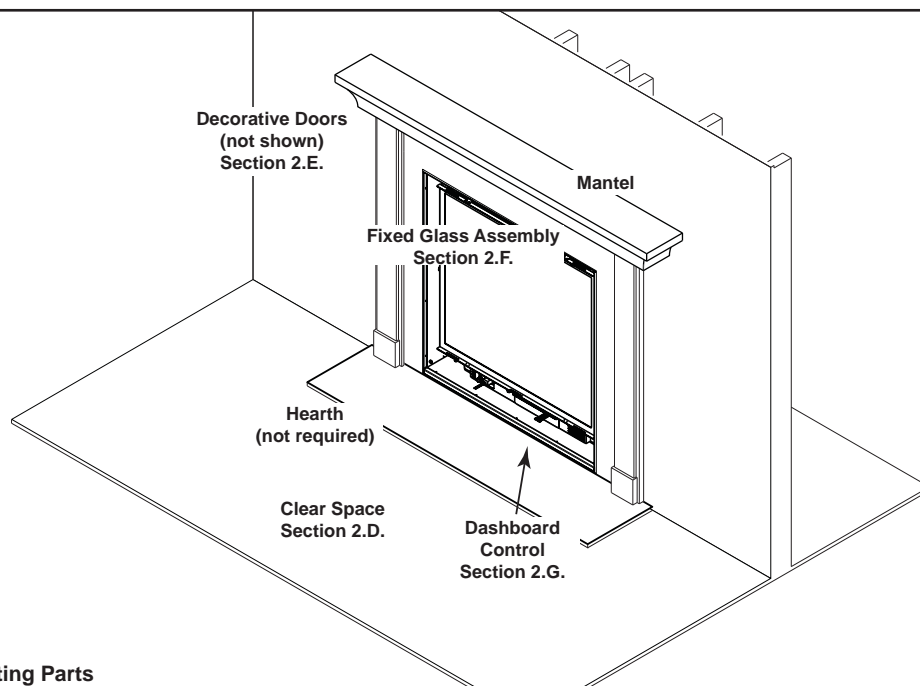

Figure 2.1 General Operating Parts

## C. Clear Space

**WARNING! DO NOT** place combustible objects in front of the fireplace or block louvers. High temperatures may start a fire. See Figure 2.2.

Avoid placing candles and other heat-sensitive objects on mantel or hearth. Heat may damage these objects.

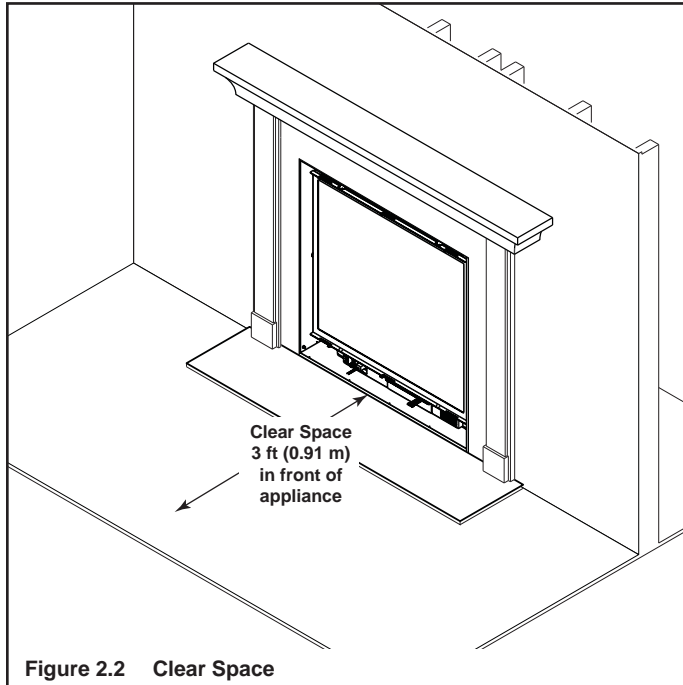

Figure 2.2 Clear Space

## D. Decorative Doors and Fronts

**WARNING! Risk of Fire!** Install *ONLY* doors or fronts approved by *Hearth & Home Technologies*. Unapproved doors or fronts may cause fireplace to overheat.

*This appliance requires the installation of a decorative front with an integral barrier to prevent direct contact with the fixed glass panel. Do NOT operate the appliance with the barrier removed.*

Contact your dealer or *Hearth & Home Technologies* if the barrier is not present or help is needed to properly install one.

For more information refer to the instructions supplied with your decorative door or front.

## E. Fixed Glass Assembly

See Section 15.A.

## F. Dashboard Control

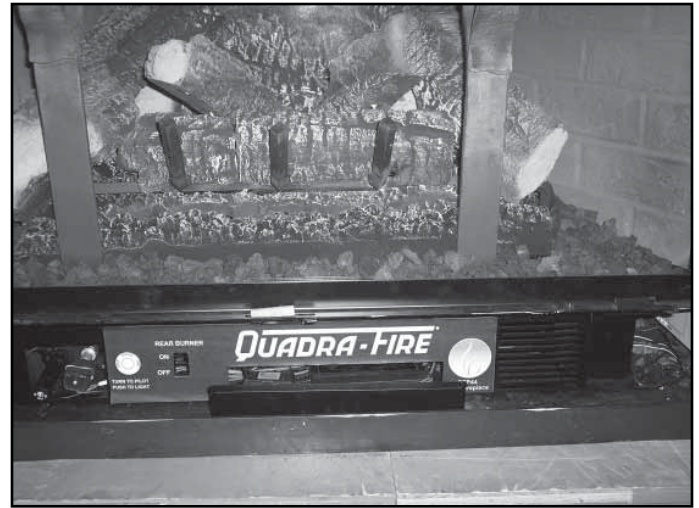

Figure 2.3 Dashboard Control

### Valve Control

This knob is used to control the gas to the appliance and for starting the pilot. There are three positions, ON, OFF, PILOT. The indicator on the valve indicates the position of the knob.

### Pilot Ignitor

This unit is equipped with an electronic ignitor for the pilot. When the valve control knob is turned to the PILOT position and fully depressed, the ignitor will begin sparking and light the pilot. After the pilot is lit, release the knob slightly to stop the ignitor from sparking but continue holding the knob in for 30 seconds to establish the pilot. Release the knob and the pilot should stay lit.

### Rear Burner Switch

The rear burner can be shut off completely with the switch, allowing the front burner to operate in either high or low mode for limited heat output.

## Ignitor Battery Box

By pulling the drawer forward, the ignitor battery box can be accessed to replace the AA battery as necessary. See Figure 13.2.

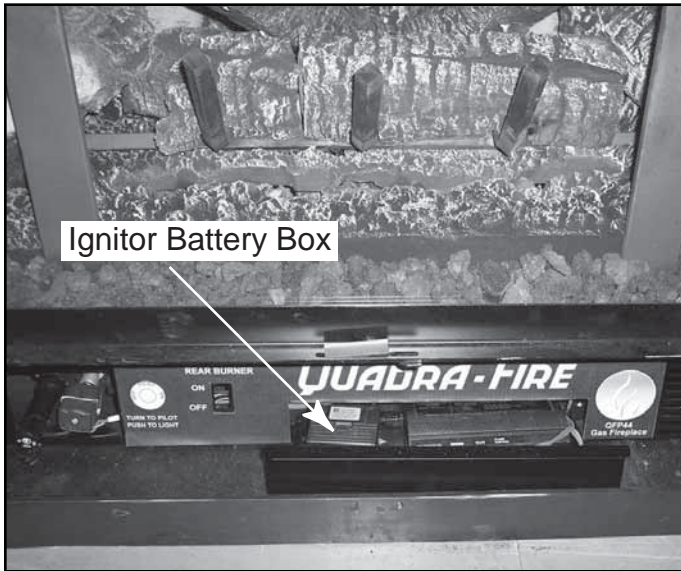

Figure 2.4 Accessing the Ignitor Battery Box.

## Ignitor Battery Box

By pulling the drawer forward, the ignitor battery box can be accessed to replace the AA battery as necessary. See Figure 2.4.

## G. Remote Operation

This remote control kit has a hand held transmitter that can be used as a remote on/off or as a thermostat. The transmitter display shows the current room temperature, target temperature, timer setting, on/off status, low battery indicator, current time, burner/valve operation and fan operation. Electrical ratings for the receiver are: 110 VAC, 60 Hz, 6 W.

## FCC REQUIREMENTS

**Warning!** CHANGES OR MODIFICATIONS TO THIS UNIT NOT EXPRESSLY APPROVED BY THE PARTY RESPONSIBLE FOR COMPLIANCE COULD VOID THE USER'S AUTHORITY TO OPERATE THE EQUIPMENT.

**Note:** This equipment has been tested and found to comply with the limits for a Class B digital device, pursuant to Part 15 of the FCC Rules. These limits are designed to provide reasonable protection against harmful interference in a residential installation. This equipment generates, uses, and can radiate radio frequency energy and, if not installed and used in accordance with the instructions, may cause harmful interference to radio communications. However, there is no guarantee that interference will not occur in a particular installation. If this equipment does cause harmful interference to radio or television reception, which can be determined by turning the equipment off and on, the user is encouraged to try to correct the interference by one or more of the following measures:

- Reorient or relocate the receiving antenna.
- Increase the separation between the equipment and receiver.
- Connect the equipment into an outlet on a circuit different from that to which the receiver is connected.
- Contact the dealer or an experienced radio TV technician for help.

## Canadian Equipment Requirements

This digital apparatus does not exceed the (Class A/ Class B) limits for radio noise emissions from digital apparatus set out in the Radio Interference Regulations of the Canadian Department of Communications. *Le présent appareil numérique n'émet pas de bruits radioélectriques dépassant les limites applicables aux appareils numériques (de la class A/de la class B) prescrites dans le Règlement sur le brouillage radioélectrique édicté par le ministère des Communications du Canada.*

This device complies with RSS-210 of Industry and Science Canada. Operation is subject to the following two conditions: (1) this device may not cause interference, and (2) this device must accept any interference, including interference that may cause undesired operation of the device.

## Remote Receiver

The remote receiver has a 3-position slide switch:

OFF/REMOTE/ON (see Figure 2.5).

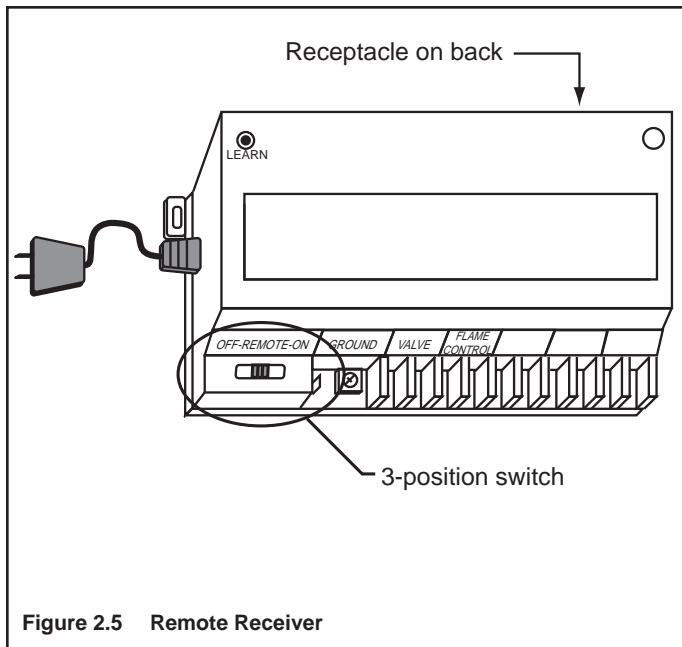

Figure 2.5 Remote Receiver

**NOTE:** The remote receiver will only respond to the transmitter when the 3-position slide button on the remote receiver is in the Remote position. If the system does not respond to the transmitter on initial use, see section Matching Security Codes.

- With the slide switch in the ON position, the system is on.
- With the slide switch in the REMOTE position, the system only operates if the remote receiver receives commands from the transmitter.
- With the slide switch in the OFF position, the system is off.

**NOTE:** The slide switch should be placed in the OFF position if you will be away from your home for an extended period of time. Placing the switch in the OFF position also functions as a safety “lock out” by turning the system off and rendering the remote receiver inoperative.

## Transmitter

**Important:** Before operating remote control, transmitter and receiver must have matching security codes. See section ‘Matching Security Codes’.

**Important:** Review ‘Thermo-Updating/Communication-Safety Features’ under ‘Transmitter Safety Features’ section. Communication Safety features shut down the fireplace system when a potentially unsafe condition exists.

**Important:** Review ‘Auto Shutdown’ section. This safety feature shuts down the fireplace after 9 hours of continuous operation, in ON mode only. **Important:** New or fully charged batteries are essential for proper operation of the multi-function transmitter. The transmitter operates on 2 AAA-size 1.5V batteries. Use Alkaline batteries for longer battery life and maximum operational performance.

Insert 2 AAA-size 1.5V batteries into the battery compartment on the back of the transmitter. When the batteries are correctly inserted, the screen will display numbers (see Figure 2.6 for LCD Display Screen).

**NOTE:** If the transmitter is activated from a very cold condition it may be necessary to allow the transmitter to stabilize to room temperature (could take up to 15 minutes) before accurate room temperatures are displayed on the screen.

**NOTE:** LCD screen is equipped with a “backlite” for easier viewing of LCD screen. Backlite illuminates when a function button is depressed. After 5 seconds elapses, LCD screen will return to its normal state.

1. **LOW** - Battery power low. Replace batteries within two weeks.
2. **TIMER** - Indicates time remaining before system shuts off, when timer-programmed, 9 - hour maximum setting.
3. **MODE** - Indicates operation MODE of system. ON indicates the system is on, either manually or thermostatically. THERMO indicates the system will automatically cycle ON/OFF, depending on programmed SET temperature. OFF indicates the entire system is turned off.
4. **SET** - Indicates desired SET room temperature for THERMO operation.
5. **FLAME** - Single or double Flame/Hi icon indicates burner/valve operational.
6. **CLOCK** - Indicates the current time in AM/PM.
7. **ROOM** - Indicates CURRENT room temperature.
8. °F - Indicates degrees Fahrenheit (°C indicates degrees Celsius).
9. **FAN** - Indicates fan is on or programmed to come on. Three speed settings are available.

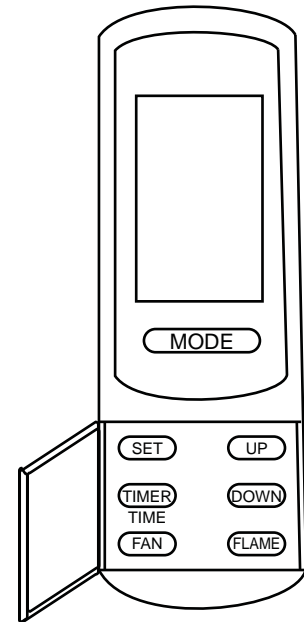
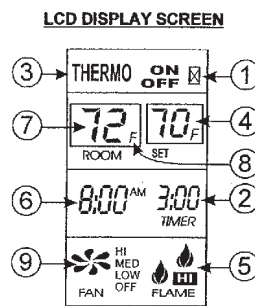

Figure 2.6 Transmitter LCD Display Screen

### Matching Security Codes

It may be necessary to program the remote receiver to the security code of the transmitter upon initial use, if batteries are replaced, or if a replacement transmitter is purchased from your dealer. To program the remote receiver:

- Set the slide button on the receiver to the REMOTE position.
- Push the LEARN button (one beep will be heard) on the top of the remote receiver.
- Then press the MODE button on the transmitter. Several beeps indicate the transmitter's code has been programmed into the receiver. When an existing receiver is matched to a new transmitter, the new security code will overwrite the old one.

**NOTE:** When the LEARN button is depressed, "beeping" sounds should be heard. If no "beeping" is heard check to see that the receiver has 110-120VAC power to it.

If you are unsuccessful in matching the security code on the first attempt, wait 1-2 minutes before trying again.

### Operating Instructions

To operate the system, press the MODE button (Figure 13.4) on the transmitter to select the operational MODE desired.

- ON indicates the system is on, either manually, timed or thermostatically.
- THERMO indicates the system will automatically cycle ON/OFF, depending on programmed set temperature.
- OFF indicates the entire system is turned off.

### Transmitter Settings

Flip open the plastic cover on the front of the transmitter to expose the "SET" buttons.

**NOTE:** Flashing numbers on the display indicate the system is waiting for input, such as using the UP and DOWN buttons to program a new setting. If no change is made to flashing digits within 15 seconds, the system will complete the procedure last programmed and reset the display to its normal state.

### Setting the Clock

- Press and hold the TIMER/TIME button on the transmitter for more than two seconds. The hour digit(s) will begin flashing (see Figure 13.4, Location #6).
- Press the UP or DOWN button until the desired hour is displayed in AM or PM.
- After setting the desired hour, press and release the TIMER/TIME button again to set the minutes; the minute digits will begin flashing.
- Press the UP or DOWN button until the desired minutes are displayed.
- Press and hold the TIMER/TIME button again for more than two seconds. The time digits will cease flashing, indicating the clock has been successfully set. You may also press the SET button on the transmitter to stop the time digits from flashing and set the time.

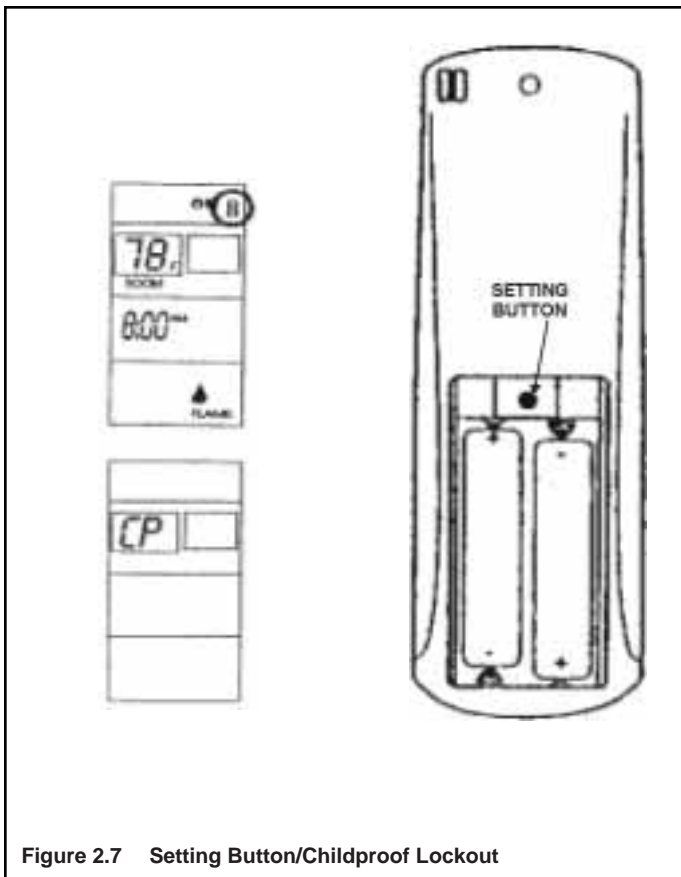

Figure 2.7 Setting Button/Childproof Lockout

### Setting °F/°C Scale

The factory setting for temperature is degrees Fahrenheit (°F). To change this setting to degrees Centigrade (°C):

- Remove the battery cover on the back of the transmitter and locate the “setting button” at the top center of battery compartment (see Figure 2.7).
- Push setting button and °F will begin flashing on the LCD screen (see Figure 13.4, Location #8).
- Push the DOWN button on the transmitter to change °F to °C.
- Push “setting button” on transmitter and Centigrade (°C) degree readings will display on LCD screen.
- Repeat this process to change back to Fahrenheit (°F) reading, this time pushing the UP button.

**NOTE:** LCD screen will return to normal state if setting button is not pushed within 15 seconds.

### Setting Desired Room Temperature - Ther-mo Operations

This remote control system can be thermostatically controlled when the transmitter is in the THERMO mode. (THERMO must be displayed on the screen). The transmitter will “sense” the room temperature every two minutes automatically turning the fireplace ON or OFF thermostatically.

To set the desired room temperature:

- Press the MODE button to place the transmitter into THERMO mode. THERMO ON or OFF will display.

- Press the UP or DOWN button to select the desired room temperature. The highest SET temperature is 99° F (32° C). The lowest SET temperature is 45° F (6° C).

**NOTE:** To prevent repeated thermo-cycling of the gas appliance, the sensing unit in the transmitter will only activate the remote receiver when the temperature change exceeds 2° F (1° C) above or below the SET (desired) temperature.

When the transmitter is in the THERMO mode, it should be kept away from direct sources of heat such as fireplaces, incandescent lighting and direct sunlight. Leaving the transmitter in direct sunlight, for example, will cause it to read the room temperature higher than it actually is.

### Setting the Countdown Timer

This remote control system can operate with a built-in countdown timer when the transmitter is in the ON or THERMO modes (THERMO or ON must be displayed on the LCD screen).

- Press and release the TIMER/TIME button on the transmitter. The word TIMER and 0:15 flash on the screen (see Figure 2.6, Location #2).
- Press the UP and DOWN button to begin advancing through each of the countdown time options. Available countdown times are 15 min, 30 min, 45 min, 1 hour, 1 hr 30 min, and each additional half hour up to nine hours.
- To set the TIMER, press the SET button on the transmitter. If the system is ON, it will remain on until the “time” has expired. If the system is in the THERMO mode, it will cycle on and off as the room temperature requires until the “time” has expired.

**NOTE:** When the timer is used in the THERMO mode, the THERMO operation will discontinue when the “time” has expired.

### Operating the Fan - Operates in ON or THER-MO mode

This remote control system has the capability of operating a 110 VAC fan or blower system that may be included with your gas fireplace. The fan will only operate when the transmitter is in the ON or THERMO mode. (THERMO or ON must be displayed on LCD screen).

- To turn fan ON, press and release the FAN button on the transmitter (see Figure 2.6, Location #9). The fan will operate at HI speed, and fan blade icon will appear on LCD screen.
- To change fan speed to MED, press and release FAN button again. To change fan speed to LO, press and release FAN button again.
- To turn fan OFF, press and release FAN button again. Fan blade icon will disappear from LCD screen.

## Adjusting the Flame Height -

### Operates in ON or THERMO mode

This remote control system allows the user to control the height of the FLAME when the gas valve is factory equipped with a FLAME CONTROLLER.

- Press and release FLAME button to change flame height to HI (see Figure 2.6, Location #5), a second flame icon appears.
- Press again to return flame to normal state.

### Low/Battery Indicator

An "X" outlined by a battery on the right side of the LCD screen will appear when battery power has dropped significantly. At this time, approximately two weeks of battery power remains.

### Child Proof Lockout (CP)

The transmitter contains a "Child Proof" lockout feature that prevents unauthorized use of the remote control. To access the "Child Proof" activation button, remove cover on BACK of transmitter. To activate LOCKOUT:

- Press and hold in the "setting button" for 5 seconds (see Figure 2.7). The letters CP will display on the LCD screen). This prevents the activation of fireplace. When any function button is pressed ON/OFF etc. the letter CP will display on the LCD screen.

To deactivate LOCKOUT:

- Press and hold in the "setting button" for 5 seconds. The LCD will display CP until 5 seconds have elapsed, and then the LCD screen will return to its normal state.

### Transmitter Safety Features

It is recommended that the TRANSMITTERS always be located within a 20 foot operating range of the fireplace, preferably in the same room in which the fireplace system is located. The TRANSMITTER features several safety features that alert the user when the TRANSMITTER is placed outside the 20 foot normal operating range.

### Thermo-Updating and Communication-Safety Features

This remote control has a COMMUNICATION-SAFETY function built into its software. It provides an extra margin of safety when the TRANSMITTER is out of the normal 20 foot operating range of the receiver. It is also activated when the batteries become weak or are removed from the transmitter.

In the THERMO-UPDATING feature (only in the THERMO or TIMER modes) the transmitter normally reads the ROOM temperature every 2 minutes. In addition to checking the temperature, the transmitter sends a signal to the receiver indicating that the transmitter and its batteries are still active.

In the COMMUNICATION-SAFETY feature, at all times and in all OPERATING MODES the transmitter sends a

signal every 15 minutes to the receiver, indicating that the transmitter is within the normal operating range of 20 feet.

Should the receiver NOT receive a transmitter signal every 15 minutes (COMMUNICATION-SAFETY feature), the RECEIVER will begin a 2 HOUR (120 minute) count-down timing function. If during this 2 hour period, the receiver does not receive a signal from the transmitter, the RECEIVER will shut down the fireplace being controlled by the receiver. The RECEIVER will then emit a series of rapid "beeps". Then, after 10 rapid "beeps", the RECEIVER will continue to emit a single "beep" every 4 seconds until a transmitter signal is again received. The intermittent 4 second beeping will go on indefinitely until reset.

To "reset" the RECEIVER and operate the fireplace system:

- Press the MODE button on the transmitter. The word ON must display on the LCD screen. The COMMUNICATION-SAFETY operation is overridden and the system will return to normal operation depending on the MODE selected at the transmitter. We recommend the user check the batteries in the TRANSMITTER to make sure the voltage is no less than 2.7 volts.

### Auto Shutdown

This remote control has an Auto Shutdown feature incorporated into its system. When the transmitter MODE is in the ON position the fireplace will continuously operate for 9 hours. After 9 hours, the fireplace will shut down. To relight the fireplace:

- Press the MODE button. The fireplace will operate continuously for up to 9 hours before Auto Shutdown repeats cycle. The Auto Shutdown signal comes from the transmitter. The transmitter must be positioned within a 20 ft operating range for the Auto Shutdown feature to operate.

### System Check

Light the appliance following the lighting instructions that came with the fireplace. Confirm that the pilot flame is on. It must be in operation for the main gas valve to operate.

- Slide the 3-position button on the remote receiver to the ON position. The main gas flame (i.e., the fire) should ignite.
- Slide the button to OFF. The flame should extinguish (the pilot flame will remain on).
- Slide the button to REMOTE (the center position), then press the MODE button on the transmitter to change the system to ON. The main gas flame should ignite.
- Press the MODE button on the transmitter to change the system to OFF. The flame should extinguish (the pilot flame will remain on).
- Press the MODE button on the transmitter to change the system to THERMO.

- Advance the SET temperature on the transmitter to a temperature of at least 2° F (1° C) above the ROOM temperature displayed on the LCD screen and the system flame will ignite.
- Set the SET temperature to at least 2° F (1° C) below the room temperature and the system flame will extinguish. Thereafter, it should continue to cycle on and off thermostatically approximately every two minutes as the ROOM temperature changes, but only when the temperature differential between ROOM and SET temperatures differs at least 2° F (1° C). The 2° F differential is the factory setting.

### Timer Operation

The countdown timer will operate in either the manual ON or THERMO mode. Once the fireplace system is in an operating mode, set the countdown timer to turn off in 15 minutes. The timer function will allow operation to continue until the “countdown time” on the LCD screen expires. After 15 minutes elapse, the system should turn off.

## General Information

### Transmitter Wall Bracket

The transmitter can be hung on a wall using the bracket provided. Locate the bracket on an inside wall sufficiently far away from direct sources of heat such as a fireplace, incandescent lighting, or sunlight so it detects ambient room temperatures, not a single heat source. If the bracket is installed on a solid wood wall, drill 1/8” pilot holes and install with the screws provided. If it is installed on a plaster/wallboard wall, first drill two 1/4” holes into the wall, then use a hammer to tap in the two plastic wall anchors flush with the wall, then install the screws provided.

### Battery Life

Life expectancy of the batteries in the transmitter should be at least 12 months. Check batteries annually. When the transmitter no longer operates the remote receiver from a distance it did previously (i.e., the transmitter’s range has decreased) the batteries should be checked.

### Specifications

Batteries: Transmitter - 3V 2 ea.; AAA 1.5V, Alkaline  
Remote - 110-120 VAC; 60Hz

Operating Frequency: 303.8 MHZ

FCC ID No.’s: Transmitter - K9L300ITX  
Receiver - K9L3003RX

Canadian ISC ID No.’s: Transmitter - 2439 102 760  
Receiver - 2439 102 760A

## H. Before Lighting Fireplace

Before operating this fireplace for the first time, **have a qualified service technician:**

- Verify all shipping materials have been removed from inside and/or underneath the firebox.
- Review proper placement of logs, rockwool and/or other decorative materials.
- Check the wiring.
- Check the air shutter adjustment.
- Ensure that there are no gas leaks.
- Ensure that the glass is sealed and in the proper position and that the integral barrier is in place.

***WARNING! Risk of Fire or Asphyxiation! DO NOT operate fireplace with fixed glass assembly removed.***



## I. Lighting Instructions (SP)

- For normal use, activate/deactivate your fireplace with the wall switch or remote control.
- If your fireplace must be deactivated for serviced or an extended period of time, follow the instructions below.

### FOR YOUR SAFETY READ BEFORE LIGHTING





**WARNING: If you do not follow these instructions exactly, a fire or explosion may result causing property damage, personal injury or loss of life**

- A. This appliance has a pilot that must be lit manually. When lighting the pilot, follow these instructions exactly.
- B. **BEFORE LIGHTING**, smell around the appliance area for gas. Be sure to smell next to the floor because some gas is heavier than air and will settle on the floor.

#### WHAT TO DO IF YOU SMELL GAS:

- \* Do not try to light any appliance.
  - \* Do not touch any electric switch, do not use any phone in your building.
  - \* Immediately call your gas supplier from a neighbor's phone. Follow the gas supplier's instructions.
  - \* If you cannot reach your gas supplier, call the fire department.
- C. Use only your hand to push in or turn the gas control knob. Never use tools. If the knob will not push in or turn by hand, don't try to repair it, call a qualified service technician. Force or attempted repair may result in a fire or explosion.
- D. Do not use this appliance if any part has been under water. Immediately call a qualified service technician to inspect the appliance and to replace any part of the control system and any gas control which has been under water.

### LIGHTING INSTRUCTIONS

1. **STOP! Read the safety information above on this label.**
2. Set the thermostat to the lowest setting (if applicable) and turn off the switch at the control panel.
3. Disconnect the power from the appliance.
4. Open the door of the appliance. May need to remove face/front first.
5. Push in gas control knob slightly and turn clockwise  to the "OFF" position. Do not force.
6. Wait five (5) minutes to clear out any gas. Smell for gas, including near the floor. If you smell gas, STOP! Follow "B" of the safety information above. If you don't smell gas go to the next step.
7. Push gas control knob in and turn counterclockwise  to the pilot position. NOTE: Knob cannot be turned unless knob is pushed in slightly. Do not force.
8. **PIEZO IGNITER:** Press down on the gas control knob in pilot position and simultaneously press the piezo igniter. (This may take many repetitions for lighting.)  
**ELECTRONIC IGNITER:** If the unit is equipped with an electronic igniter it should begin sparking right away.
9. The pilot should be visible through the door opening.
10. After the pilot is lit, continue holding control knob down for approximately 30 seconds. Release the knob and it will pop back up. Pilot should remain lit. If it goes out, repeat steps 7 through 9.
  - \* If the knob does not pop up when released, stop and immediately call your service technician or gas supplier.
  - \* If the pilot will not stay lit after several tries, turn the gas control knob clockwise  to "OFF" and call your service technician or gas supplier.
11. Reinstall door and face. Wait five minutes to allow pilot flame to stabilize and establish proper draft.
12. Push down and turn gas control knob counterclockwise  to "ON".
13. Use remote transmitter to operate the unit. If thermostat is to be used, leave switch in "OFF" position and set the thermostat to desired setting.
14. Reconnect electrical power to appliance.

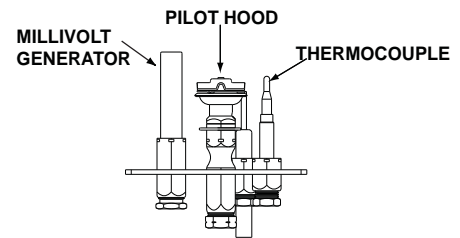
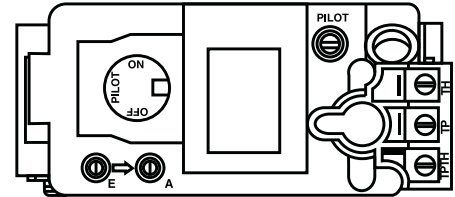

### TO TURN OFF GAS TO APPLIANCE

1. Turn unit off with remote.
2. Turn off all electric power to the appliance if service is to be performed.
3. Push in gas control knob slightly and turn clockwise  to "OFF" position.

## J. After Fireplace is Lit

### Initial Break-in Procedure

- The fireplace should be run three to four hours continuously on high.
- Turn the fireplace off and allow it to completely cool.
- Remove fixed glass assembly. See Section 15.A.
- Clean fixed glass assembly. See Section 3.A.
- Replace the fixed glass assembly and run continuously on high an additional 12 hours.

This cures the materials used to manufacture the fireplace.

**NOTICE!** Open windows for air circulation during fireplace break-in.

- Some people may be sensitive to smoke and odors.
- Smoke detectors may activate.

## K. Frequently Asked Questions

ISSUE	SOLUTIONS
Condensation on the glass	This is a result of gas combustion and temperature variations. As the appliance warms, this condensation will disappear.
Blue flames	This is a result of normal operation and the flames will begin to yellow as the appliance is allowed to burn for 20 to 40 minutes.
Odor from appliance	When first operated, this appliance may release an odor for the first several hours. This is caused by the curing of materials from manufacturing. Odor may also be released from finishing materials and adhesives used near the appliance. These circumstances may require additional curing related to the installation environment.
Film on the glass	This is a normal result of the curing process of the paint and logs. Glass should be cleaned within 3 to 4 hours of initial burning. A non-abrasive cleaner such as gas appliance glass cleaner may be necessary. See your dealer.
Metallic noise	Noise is caused by metal expanding and contracting as it heats up and cools down, similar to the sound produced by a furnace or heating duct. This noise does not affect the operation or longevity of the appliance.
Is it normal to see the pilot flame burn continually?	In an IntelliFire ignition system (IPI), the pilot flame should turn off when appliance is turned off. Some optional control systems available with IPI models may allow pilot flame to remain lit. In a standing pilot system the pilot will always stay on.

# 3 Maintenance and Service

Any safety screen or guard removed for servicing must be replaced prior to operating the fireplace.

When properly maintained, your fireplace will give you many years of trouble-free service. We recommend annual service by a qualified service technician.

## A. Maintenance Tasks-Homeowner

Installation and repair should be done by a qualified service technician only. The fireplace should be inspected before use and at least annually by a professional service person.

The following tasks may be performed annually by the homeowner. If you are uncomfortable performing any of the listed tasks, please call your dealer for a service appointment.

More frequent cleaning may be required due to lint from carpeting or other factors. Control compartment, burner and circulating air passageway of the fireplace must be kept clean.

**CAUTION! Risk of Burns!** The fireplace should be turned off and cooled before servicing.

### Glass Cleaning

**Frequency:** Seasonally

**By:** Homeowner

**Tools Needed:** Protective gloves, glass cleaner, drop cloth and a stable work surface.

**CAUTION! Handle fixed glass assembly with care.**  
*Glass is breakable.*

- Avoid striking, scratching or slamming glass
- Avoid abrasive cleaners
- DO NOT clean glass while it is hot
- Prepare a work area large enough to accommodate fixed glass assembly and door frame by placing a drop cloth on a flat, stable surface.

**Note:** Fixed glass assembly and gasketing may have residue that can stain carpeting or floor surfaces.

- Remove door or decorative front from fireplace and set aside on work surface.
- See Section 15.A for instructions to remove fixed glass assembly.
- Clean glass with a non-abrasive commercially available cleaner.
  - Light deposits: Use a soft cloth with soap and water
  - Heavy deposits: Use commercial fireplace glass cleaner (consult with your dealer)
- Carefully set fixed glass assembly in place on fireplace. Hold glass in place with one hand and secure glass latches with the other hand.
- Reinstall door or decorative front.

## Doors, Surrounds, Fronts

**Frequency:** Annually

**By:** Homeowner

**Tools needed:** Protective gloves, stable work surface

- Assess condition of screen and replace as necessary.
- Inspect for scratches, dents or other damage and repair as necessary.
- Check that louvers are not blocked.
- Vacuum and dust surfaces.

## Remote Control

**Frequency:** Seasonally

**By:** Homeowner

**Tools needed:** Replacement batteries and remote control instructions.

- Locate remote control transmitter and receiver.
- Verify operation of remote. Refer to remote control operation instructions for proper calibration and setup procedure.
- Place batteries as needed in remote transmitters and battery-powered receivers.
- Place remote control out of reach of children.

If not using your fireplace for an extended period of time (summer months, vacations/trips, etc), to prevent unintended operation:

- Remove batteries from remote controls.
- Unplug 3 volt adapter plug on IPI models.

## Venting

**Frequency:** Seasonally

**By:** Homeowner

**Tools needed:** Protective gloves and safety glasses.

- Inspect venting and termination cap for blockage or obstruction such plants, bird nests, leaves, snow, debris, etc.
- Verify termination cap clearance to subsequent construction (building additions, decks, fences, or sheds). See Section 6.
- Inspect for corrosion or separation.
- Verify weather stripping, sealing and flashing remains intact.
- Inspect draft shield to verify it is not damaged or missing.

## B. Maintenance Tasks-Qualified Service Technician

The following tasks must be performed by a qualified service technician.

### Gasket Seal and Glass Assembly Inspection

**Frequency:** Annually

**By:** Qualified Service Technician

**Tools needed:** Protective gloves, drop cloth and a stable work surface.

- Inspect gasket seal and its condition.
- Inspect fixed glass assembly for scratches and nicks that can lead to breakage when exposed to heat.
- Confirm there is no damage to glass or glass frame. Replace as necessary.
- Verify that fixed glass assembly is properly retained and attachment components are intact and not damaged. Replace as necessary.

### Logs

**Frequency:** Annually

**By:** Qualified Service Technician

**Tools needed:** Protective gloves.

- Inspect for damaged or missing logs. Replace as necessary. Refer to Section 15.F. for log placement instructions.
- Verify correct log placement and no flame impingement causing sooting. Correct as necessary.

### Firebox

**Frequency:** Annually

**By:** Qualified Service Technician

**Tools needed:** Protective gloves, sandpaper, steel wool, cloths, mineral spirits, primer and touch-up paint.

- Inspect for paint condition, warped surfaces, corrosion or perforation. Sand and repaint as necessary.
- Replace fireplace if firebox has been perforated.

### Control Compartment and Firebox Top

**Frequency:** Annually

**By:** Qualified Service Technician

**Tools needed:** Protective gloves, vacuum cleaner, dust cloths

- Vacuum and wipe out dust, cobwebs, debris or pet hair. Use caution when cleaning these areas. Screw tips that have penetrated the sheet metal are sharp and should be avoided.
- Remove all foreign objects.
- Verify unobstructed air circulation.

## Burner Ignition and Operation

**Frequency:** Annually

**By:** Qualified Service Technician

**Tools needed:** Protective gloves, vacuum cleaner, whisk broom, flashlight, voltmeter, indexed drill bit set, and a manometer.

- Verify burner is properly secured and aligned with pilot or igniter.
- Clean off burner top, inspect for plugged ports, corrosion or deterioration. Replace burner if necessary.
- Replace rockwool with new dime-size pieces. DO NOT block ports or obstruct lighting paths. Refer to Section 15.F. for proper rockwool placement.
- Verify batteries have been removed from battery back-up IPI systems to prevent premature battery failure or leaking.
- Check for smooth lighting and ignition carryover to all ports. Verify that there is no ignition delay.
- Inspect for lifting or other flame problems.
- Verify air shutter setting is correct. See Section 14.D. for required air shutter setting. Verify air shutter is clear of dust and debris.
- Inspect orifice for soot, dirt and corrosion. Verify orifice size is correct. See Service Parts List for proper orifice sizing.
- Verify manifold and inlet pressures. Adjust regulator as required.
- Inspect pilot flame pattern and strength. See Figure 3.1 for proper pilot flame pattern. Clean or replace orifice spud as necessary.
- Inspect thermocouple/thermopile or IPI flame sensing rod for soot, corrosion and deterioration. Polish with fine steel wool or replace as required.
- Verify thermocouple/thermopile or IPI millivolt output. Replace as necessary.

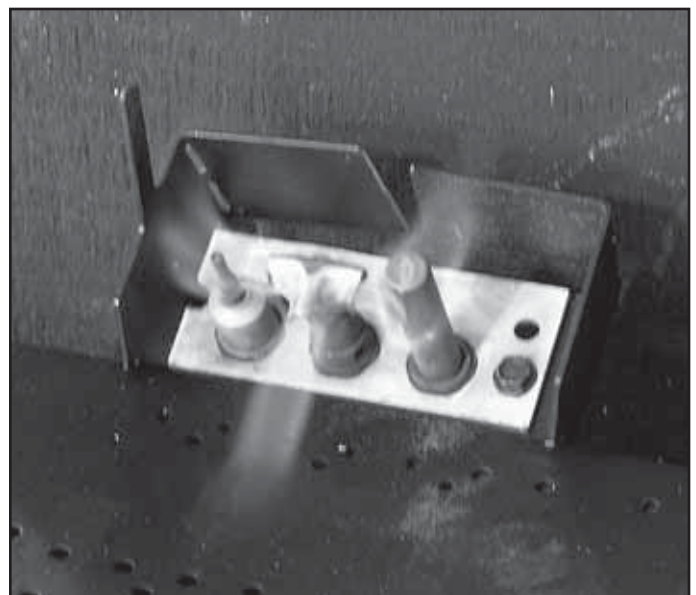

Figure 3.1 Standing Pilot Flame Patterns

# 4 Getting Started

# Installer Guide

## A. Typical Appliance System

**NOTICE:** Illustrations and photos reflect typical installations and are for design purposes only. Illustrations/diagrams are not drawn to scale. Actual product may vary from pictures in manual

**Note:** Dual venting configurations **ARE NOT** allowed. Appliance **MUST** be vented **EITHER** vertically **OR** horizontally.

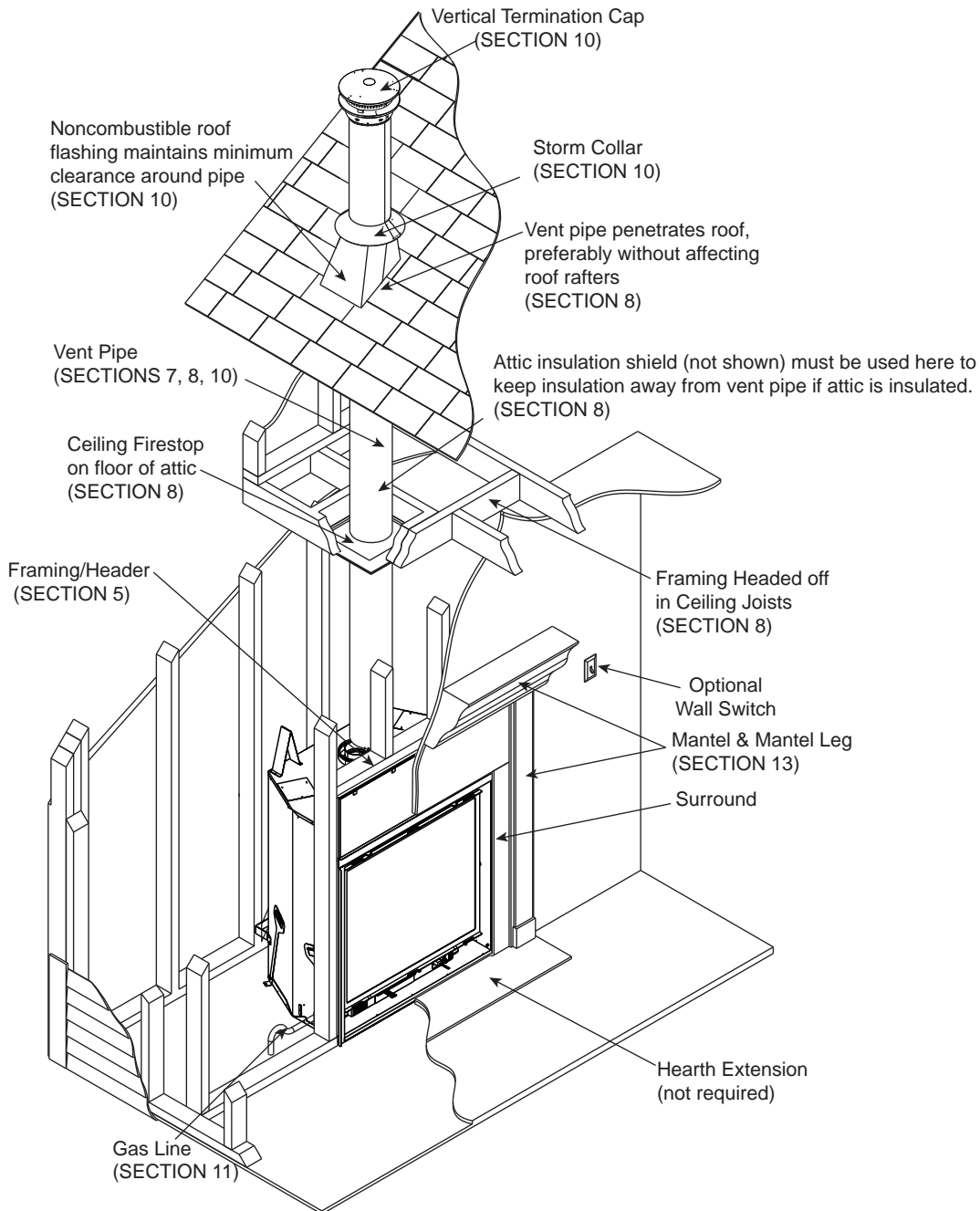

Figure 4.1 Typical System

## B. Design and Installation Considerations

Quadra-Fire direct vent gas appliances are designed to operate with all combustion air siphoned from outside of the building and all exhaust gases expelled to the outside. No additional outside air source is required.

Installation **MUST** comply with local, regional, state and national codes and regulations. Consult insurance carrier, local building inspector, fire officials or authorities having jurisdiction over restrictions, installation inspection and permits.

Before installing, determine the following:

- Where the appliance is to be installed.
- The vent system configuration to be used.
- Gas supply piping.
- Electrical wiring requirements.
- Framing and finishing details.
- Whether optional accessories—devices such as a fan, wall switch, or remote control—are desired.

Improper installation, adjustment, alteration, service or maintenance can cause injury or property damage. For assistance or additional information, consult a qualified service technician, service agency or your dealer.

## C. Tools and Supplies Needed

Before beginning the installation be sure that the following tools and building supplies are available.

Tape measure	Framing material
Pliers	Non-corrosive leak check solution
Hammer	Phillips screwdriver
Gloves	Framing square
Voltmeter	Electric drill and bits (1/4 in.)
Plumb line	Safety glasses
Level	Reciprocating saw
Manometer	Flat blade screwdriver

1/2 - 3/4 in. length, #6 or #8 Self-drilling screws

Caulking material (300°F minimum continuous exposure rating)

One 1/4 in. female connection (for optional fan).

**WARNING! Risk of Fire, Explosion or Electric Shock!**  
*DO NOT use this appliance if any part has been under water. Call a qualified service technician to inspect the appliance and to replace any part of the control system and/or gas control which has been under water.*

## D. Inspect Appliance and Components

- Carefully remove the appliance and components from the packaging (refer to Figure 4.2).
  - Remove refractory from back of unit by removing the screws from shipping bracket.
  - Remove screws from shipping brackets before trying to remove unit from pallet.
  - Remove and save screws from andirons for later installation.
  - Remove screw from top of each carrying handle. Handles have been provided to assist in moving the unit.
- The vent system components and decorative doors and fronts are shipped in separate packages.
- Report to your dealer any parts damaged in shipment, particularly the condition of the glass.
- Read all of the instructions before starting the installation. Follow these instructions carefully during the installation to ensure maximum safety and benefit.

**WARNING! Risk of Fire or Explosion!** Damaged parts could impair safe operation. **DO NOT** install damaged, incomplete or substitute components. Keep appliance dry.

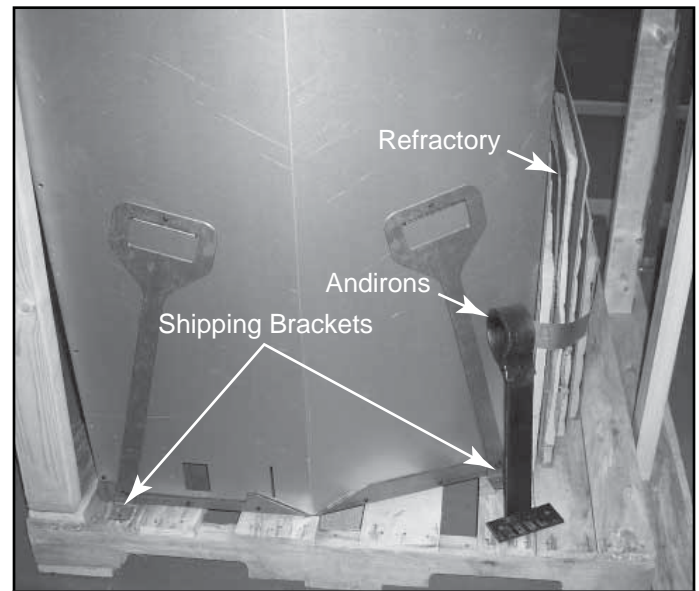

**Figure 4.2 Refractory Shipping Location, Brackets**

Hearth & Home Technologies disclaims any responsibility for, and the warranty will be voided by, the following actions:

- Installation and use of any damaged appliance or vent system component.
- Modification of the appliance or vent system.
- Installation other than as instructed by Hearth & Home Technologies.
- Improper positioning of the gas logs or the glass door.
- Installation and/or use of any component part not approved by Hearth & Home Technologies.

**Any such action may cause a fire hazard.**

# 5 Framing and Clearances

## A. Select Appliance Location

When selecting a location for the appliance it is important to consider the required clearances to walls (see Figure 5.1).

**WARNING! Risk of Fire or Burns! Provide adequate clearance around air openings and for service access. Due to high temperatures, the appliance should be located out of traffic and away from furniture and draperies.**

**NOTICE: Illustrations reflect typical installations and are FOR DESIGN PURPOSES ONLY. Illustrations/diagrams are not drawn to scale. Actual installation may vary due to individual design preference.**

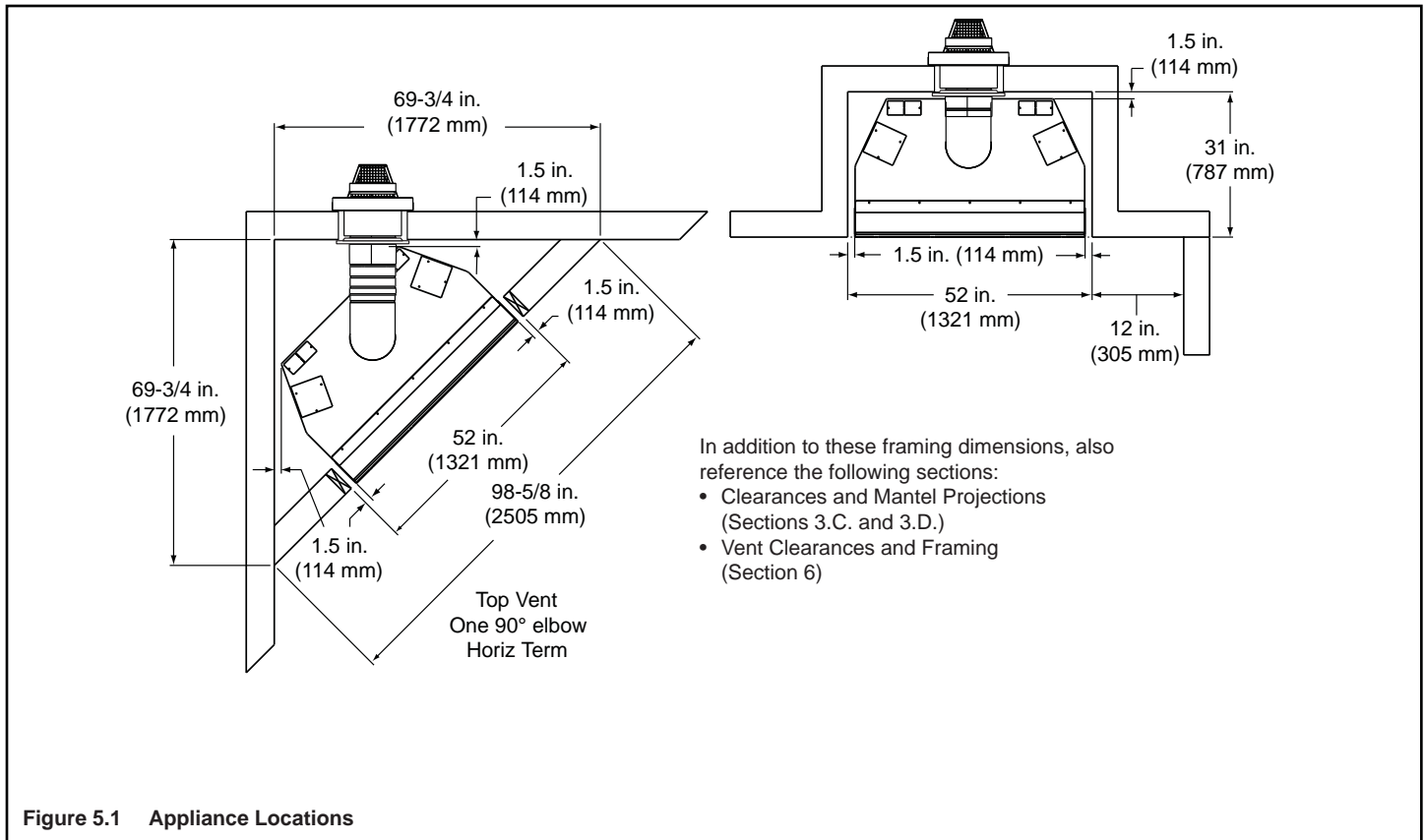

Figure 5.1 Appliance Locations

## B. Construct the Appliance Chase

A chase is a vertical box-like structure built to enclose the gas appliance and/or its vent system. In cooler climates the vent should be enclosed inside the chase.

**NOTICE:** Treatment of ceiling firestops and wall shield firestops and construction of the chase may vary with the type of building. These instructions are not substitutes for the requirements of local building codes. Therefore, you **MUST** check local building codes to determine the requirements to these steps.

Chases should be constructed in the manner of all outside walls of the home to prevent cold air drafting problems. The chase should not break the outside building envelope in any manner.

Walls, ceiling, base plate and cantilever floor of the chase should be insulated. Vapor and air infiltration barriers should be installed in the chase as per regional codes for the rest of the home. Additionally, in regions where cold air infiltration may be an issue, the inside surfaces may be sheetrocked and taped for maximum air tightness.

To further prevent drafts, the wall shield and ceiling firestops should be caulked with caulk with a minimum of 300°F

continuous exposure rating to seal gaps. Gas line holes and other openings should be caulked with caulk with a minimum of 300°F continuous exposure rating or stuffed with unfaced insulation. If the appliance is being installed on a cement slab, a layer of plywood may be placed underneath to prevent conducting cold up into the room.

## C. Clearances

**NOTICE:** Install appliance on hard metal or wood surfaces extending full width and depth. **DO NOT** install directly on carpeting, vinyl, tile or any combustible material other than wood.

**WARNING! Risk of Fire!** Maintain specified air space clearances to appliance and vent pipe:

- Insulation and other materials must be secured to prevent accidental contact.
- The chase must be properly blocked to prevent blown insulation or other combustibles from entering and making contact with fire replace or chimney.
- Failure to maintain airspace may cause overheating and a fire.

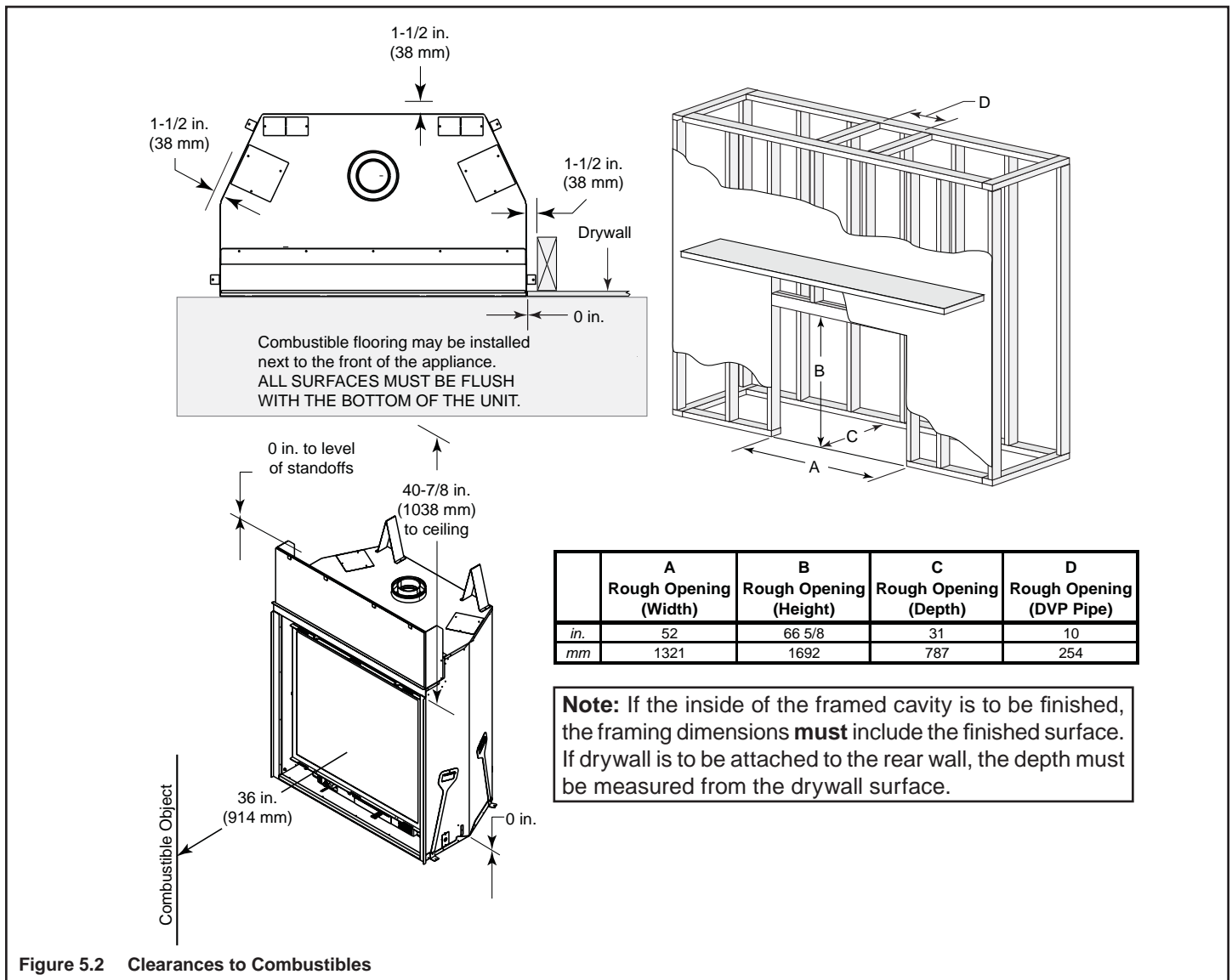

Figure 5.2 Clearances to Combustibles



## D. Mantel and Wall Projections

**WARNING! Risk of Fire!** Comply with all minimum clearances to combustibles as specified. Framing or finishing material closer than the minimums listed must be constructed entirely of non-combustible materials (i.e., steel studs, concrete board, etc).

### Mantels

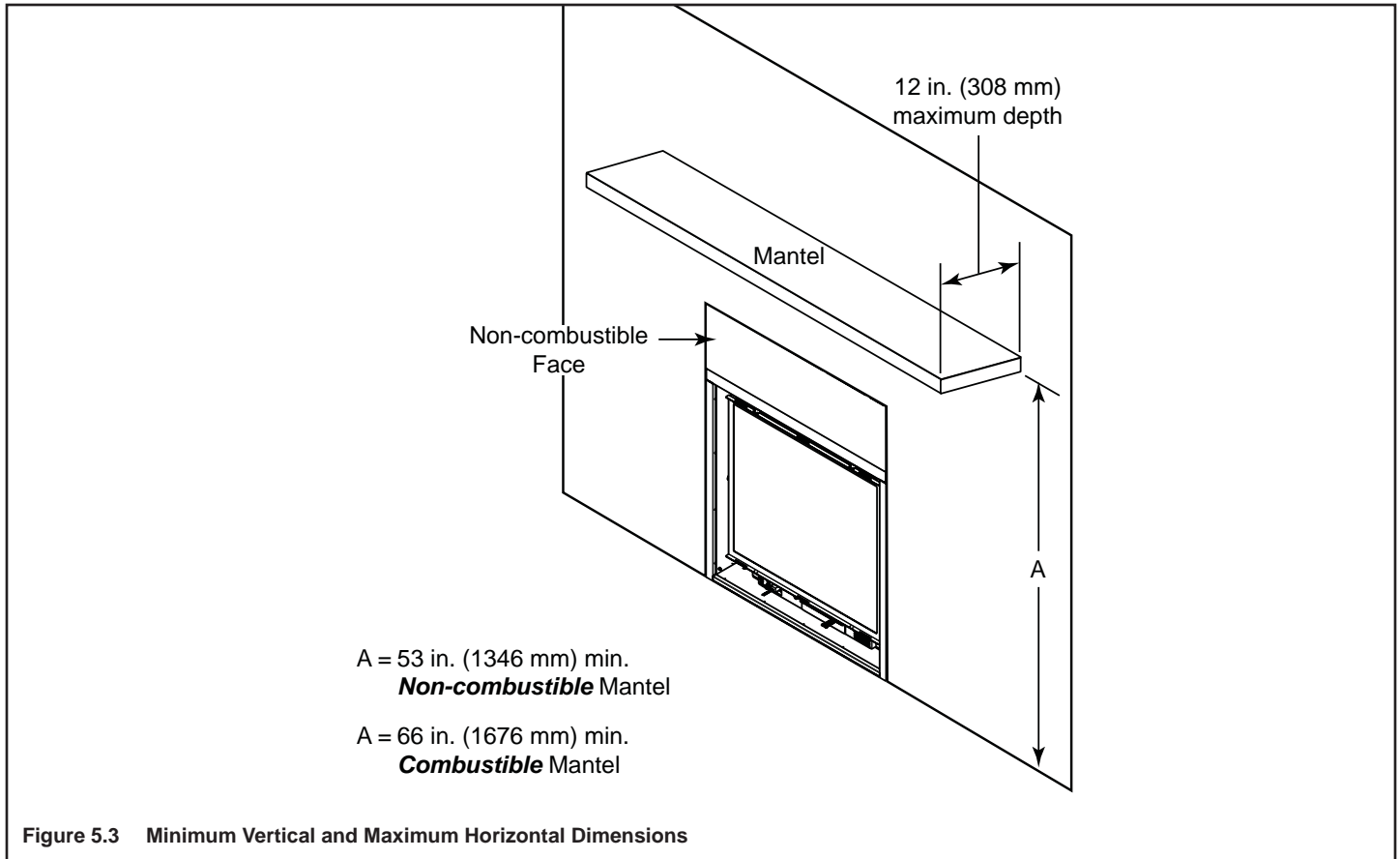

### Mantel Legs or Wall Projections

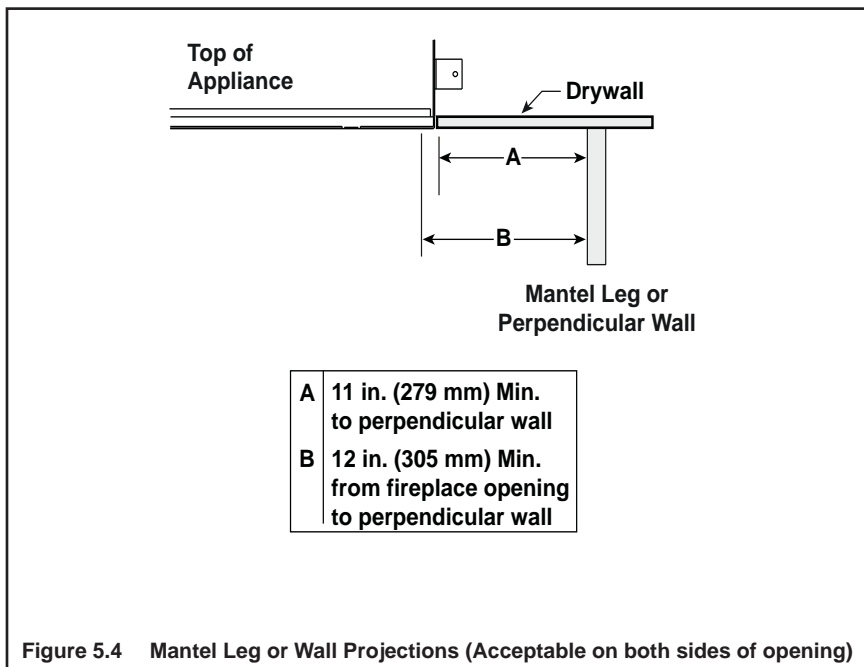

# 6 Termination Locations

## A. Vent Termination Minimum Clearances

**⚠ WARNING**

**Fire Risk.**  
Maintain vent clearance to combustibles as specified.

- **DO NOT** pack air space with insulation or other materials.

Failure to keep insulation or other materials away from vent pipe may cause overheating and fire.

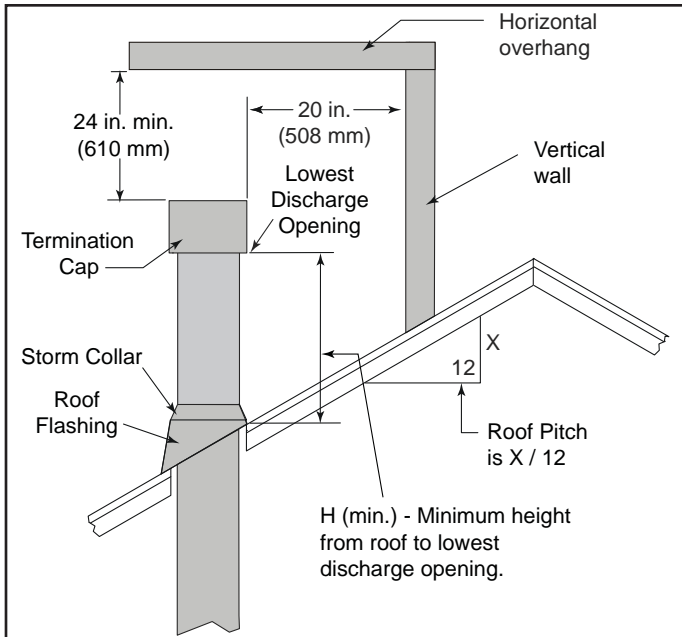

Roof Pitch	H (Min.) Ft.	Roof Pitch	H (Min.) Ft.
Flat to 6/12	1.0*	Over 11/12 to 12/12	4.0
Over 6/12 to 7/12	1.25*	Over 12/12 to 14/12	5.0
Over 7/12 to 8/12	1.5*	Over 14/12 to 16/12	6.0
Over 8/12 to 9/12	2.0*	Over 16/12 to 18/12	7.0
Over 9/12 to 10/12	2.5	Over 18/12 to 20/12	7.5
Over 10/12 to 11/12	3.25	Over 20/12 to 21/12	8.0

\* 3 ft. minimum in snow regions

**Figure 6.1 Minimum Height From Roof To Lowest Discharge Opening**

A	B
6 in. (minimum) up to 20 in. 152 mm/508 mm	18 in. minimum 457 mm
20 in. and over	0 in. minimum

Gas, Wood or Fuel Oil Termination Cap

Gas Termination Cap \*

Gas Termination Cap \*\*

\* If using decorative cap cover(s), this distance may need to be increased. Refer to the installation instructions supplied with the decorative cap cover.

\*\* In a staggered installation with both gas and wood or fuel oil terminations, the wood or fuel oil termination cap must be higher than the gas termination cap.

**Figure 6.2 Multiple Termination Caps**

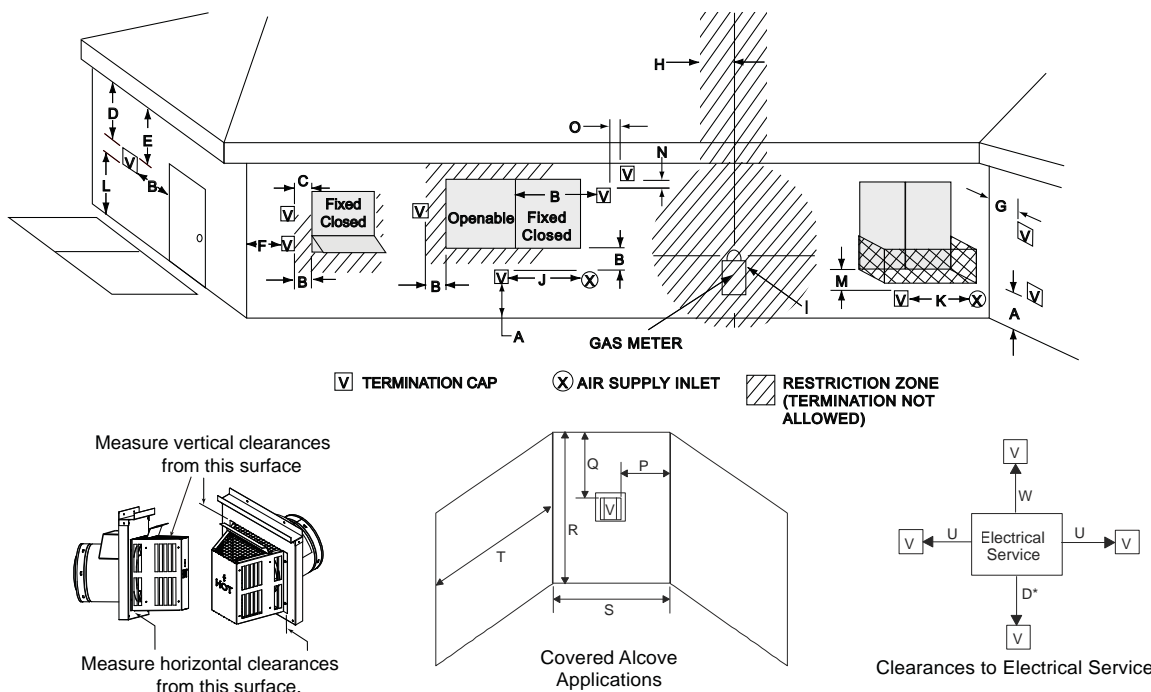

**Dimension Descriptions**

- A Clearance above the ground, a veranda, porch, deck or balcony - 12 in. (30 cm) minimum. \*
- B Clearance to window or door that may be opened – 10,000 BTUs or less, 6 in. (15 cm) minimum; 10,000-50,000 BTUs, 9 in. (23 cm) minimum; over 50,000 BTUs, 12 in. (30 cm) minimum. \*
- C Clearance to permanently closed window – 12 in. (30 cm) minimum - recommended to prevent condensation on window.
- D Vertical clearance to ventilated soffit located above the termination within a horizontal distance of 2 ft (60 cm) from the centerline of the termination – 18 in. (46 cm) minimum. \*\*
- E Vertical clearance to unventilated soffit - 12 in. (30 cm) minimum. \*\*
- F Clearance to outside corner - 6 in. (15 cm) minimum.
- G Clearance to inside corner - 6 in. (15 cm) minimum.
- H Not to be installed above a meter/regulator assembly within 3 ft (90 cm) horizontally\* from the center line of the regulator (Canada only)
- I Clearance to service regulator vent outlet – 3 ft (.91 m) U.S. minimum and 3 ft (.91 m) Canada minimum. \*
- J Clearance to non-mechanical air supply inlet into building or the combustion air inlet to any other appliance – 9" (23 cm) U.S. minimum and 12 in. (30 cm) Canada minimum. \*
- K Clearance to mechanical air supply inlet - 3 ft (.91 m) U.S. minimum and 6 ft (1.8 m) Canada minimum. \*
- L Clearance above a paved sidewalk or paved driveway located on public property - 7 ft (2.1 m) minimum.  
A vent may not terminate directly above a sidewalk or paved driveway which is located between two single family dwellings and serves both dwellings.
- M Clearance under veranda, porch, deck or balcony - 12 in. (30 cm) minimum. \* Recommended 30 in. (76 cm) for vinyl or plastic.  
Only permitted if veranda, porch, deck or balcony is fully open on a minimum of 2 sides beneath the floor. \*
- N Vertical clearance between two horizontal termination caps – 12 in. (30 cm) minimum.
- O Horizontal clearance between two horizontal termination caps – 12 in. (30 cm) minimum.

- P 6" - Non-vinyl sidewalls  
12" – Vinyl sidewalls
- Q 18" – Non-vinyl soffit and overhang  
42" – Vinyl soffit and overhang
- R 8 ft.

	<b>S<sub>min</sub></b>	<b>T<sub>max</sub></b>
1 cap	3 ft	2 x S actual
2 caps	6 ft	1 x S actual
3 caps	9 ft	2/3 x S actual
4 caps	12 ft	1/2 x S actual
S <sub>min</sub> = # term caps x 3		T <sub>max</sub> = (2/# term caps) x S (actual)

- U 6" min. – Clearance from sides of electrical service.
- W 12" min. – Clearance above electrical service.
- \* As specified in CGA B149 Installation Codes  
Note: Local codes or regulations may require different clearances.
- \*\* Clearance required to vinyl soffit material – 30 in. (76 cm) minimum.  
Note: Location of the vent termination must not interfere with access to the electrical service.

**WARNING!**

In the U.S.: Vent system termination is NOT permitted in screened porches. You must follow side wall, overhang and ground clearances as stated in the instructions.

In Canada: Vent system termination is NOT permitted in screened porches. Vent system termination is permitted in porch areas with two or more sides open. You must follow all side wall, overhang and ground clearances as stated in the instructions.

Hearth & Home Technologies assumes no responsibility for the improper performance of the appliance when the venting system does not meet these requirements.

**Figure 6.3 Minimum Clearances for Termination**

**CAUTION: IF EXTERIOR WALLS ARE FINISHED WITH VINYL SIDING, IT IS SUGGESTED THAT A VINYL PROTECTOR KIT BE INSTALLED.**

# 7 Vent Information and Diagrams

## A. Approved Pipe

This appliance is approved for use with Hearth & Home Technologies DVP venting systems. Refer to Section 17.B. for vent component information.

**DO NOT** mix pipe, fittings or joining methods from different manufacturers.

The pipe is tested to be run inside an enclosed wall. There is no requirement for inspection openings at each joint within the wall.

**WARNING! Risk of Fire or Asphyxiation.** This appliance requires a separate vent. **DO NOT** vent to a pipe serving a separate solid fuel burning appliance.

## B. Vent Table Key

The abbreviations listed in this vent table key are used in the vent diagrams.

Symbol	Description
V <sub>1</sub>	First section (closest to appliance) of vertical length
V <sub>2</sub>	Second section of vertical length
H <sub>1</sub>	First section (closest to appliance) of horizontal length
H <sub>2</sub>	Subsequent sections of horizontal length

## C. Use of Elbows

Diagonal runs have both vertical and horizontal vent aspects when calculating the effects. Use the rise for the vertical aspect and the run for the horizontal aspect (see Figure 7.1).

Two 45° elbows may be used in place of one 90° elbow. On 45° runs, one foot of diagonal is equal to 8-1/2 in. (216 mm) horizontal run and 8-1/2 in. (216 mm) vertical run. A length of straight pipe is allowed between two 45° elbows (see Figure 7.1).

## D. Measuring Standards

Vertical and horizontal measurements listed in the vent diagrams were made using the following standards.

- Pipe measurements are shown using the effective length of pipe (see Figure 7.2).
- Horizontal terminations are measured to the outside mounting surface (flange of termination cap) (see Figure 6.4).
- Vertical terminations are measured to bottom of termination cap.
- Horizontal pipe installed level with no rise.

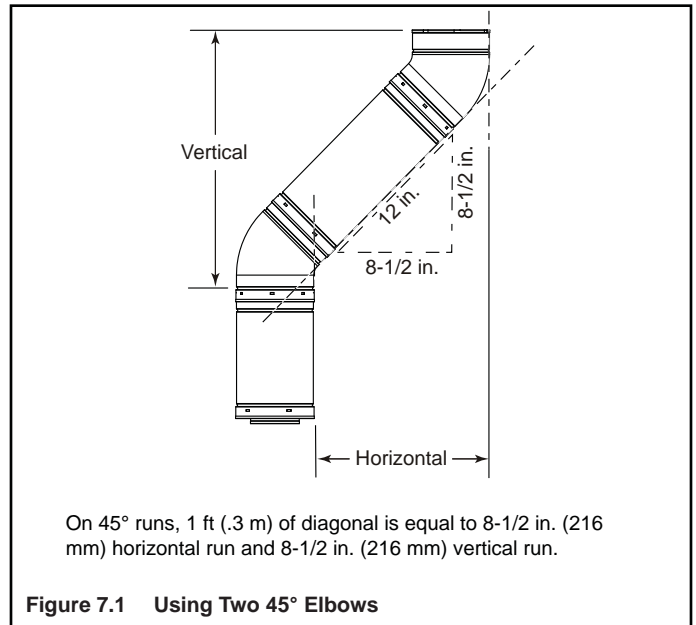

Figure 7.1 Using Two 45° Elbows

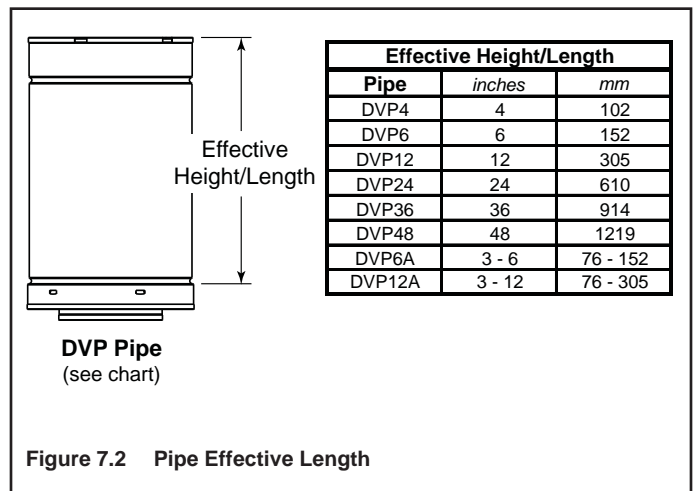

Figure 7.2 Pipe Effective Length

## E. Vent Diagrams

To replace the first starter elbow with two 45° elbows, refer to Figure 7.4. All other 90° elbows can be replaced with two 45° elbows.

General Rules:

- SUBTRACT 3 ft. from the total H measurement for each 90° elbow installed horizontally.
- SUBTRACT 1-1/2 ft. from the total H measurement for each 45° elbow installed horizontally.
- A maximum of three 90° elbows (or six 45° elbows) may be used in any vent configuration. Some elbows may be installed horizontally. See Figure 7.9.
- Elbows may be placed back to back anywhere in the system as long as the first 90° elbow is a starter elbow except as shown in Figure 7.4.
- When penetrating a combustible wall, a wall shield firestop must be installed.
- When penetrating a combustible ceiling, a ceiling firestop must be installed.
- Horizontal runs of vent do not require vertical rise; horizontal runs may be level.

### 1. Top Vent - Horizontal Termination

#### One Elbow

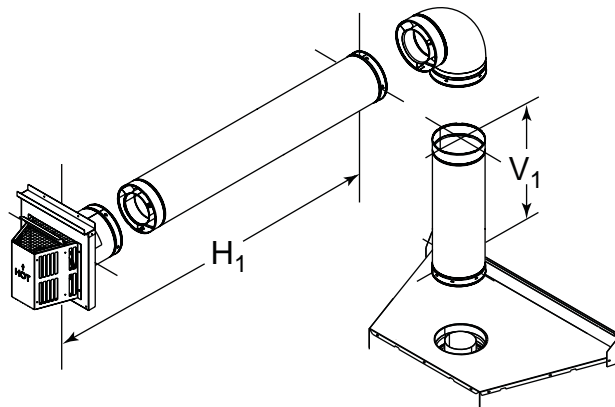

V <sub>1</sub> Min.	V <sub>1</sub> Max.	H <sub>1</sub> Max.
3 ft (.91 m)	-	1.5 ft (.46 m)
4 ft (1.22 m)	-	6 ft (1.83 m)
5 ft (1.52)	-	11 ft (3.35 m)
6 ft (1.83 m)	-	13 ft (3.96 m)
7 ft (2.13 m)	-	15 ft (4.57 m)
10 ft (3.05 m)	25 ft (7.62 m)	20 ft (6.10 m)

Figure 7.3

# 1. Top Vent - Horizontal Termination - (continued)

## Two 45° Elbows replacing One 90° Elbow

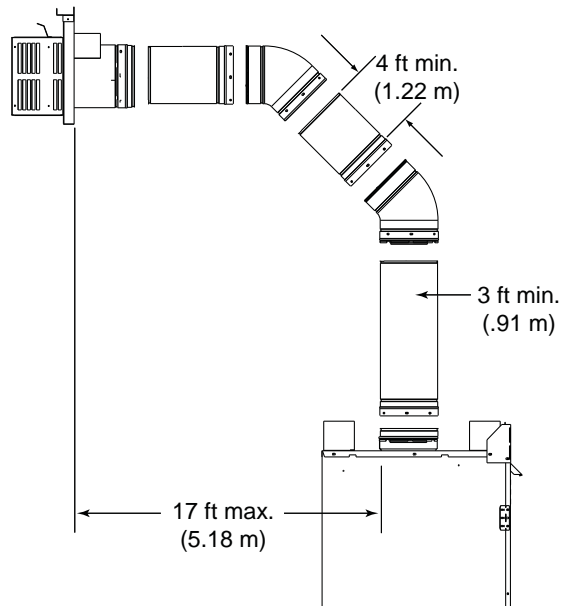

Figure 7.4

## Three Elbows

V1	H1	V2	H2
3 ft (.91 m)	3 ft (.91 m)	4 ft (1.22 m)	4 ft (1.22 m)
6 ft (1.83 m)	8 ft (2.45 m)	8 ft (2.45 m)	12 ft (3.66 m)

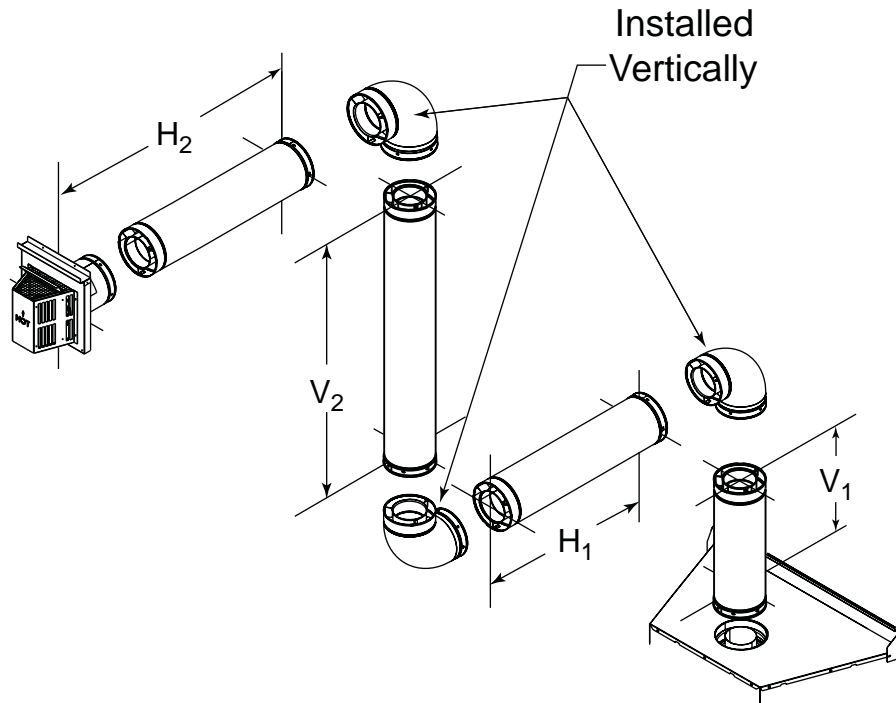
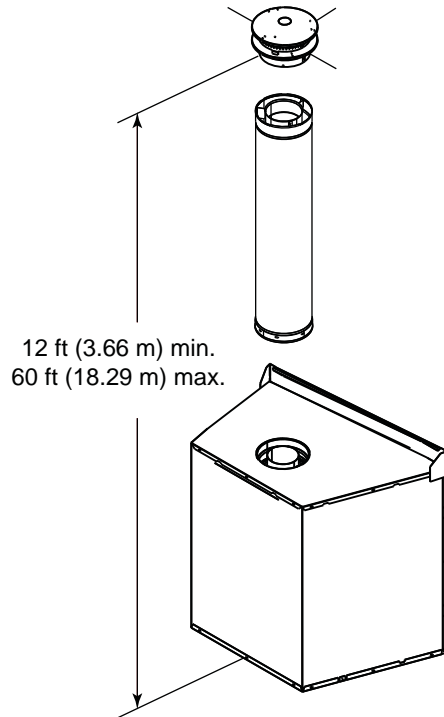

Figure 7.5

## 2. Top Vent - Vertical Termination

### No Elbow



**Note:** If installing a vertical vent/termination off the top of the appliance, the flue restrictor should be used. See Section 15.E. for necessary damper adjustment.

Figure 7.7

### Two Elbows

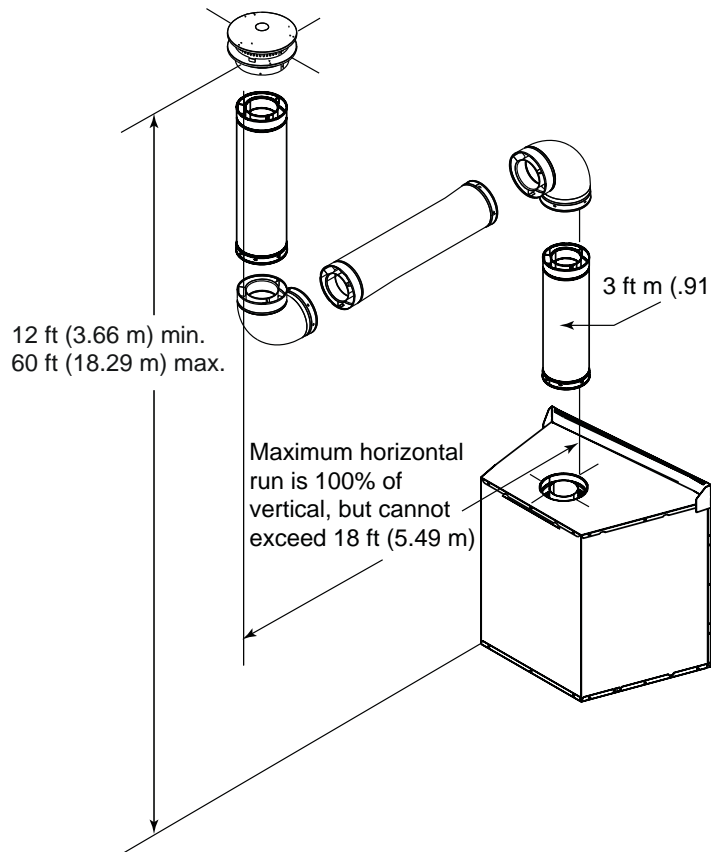

Figure 7.8

## 2. Top Vent - Vertical Termination - (continued)

### Three Elbows

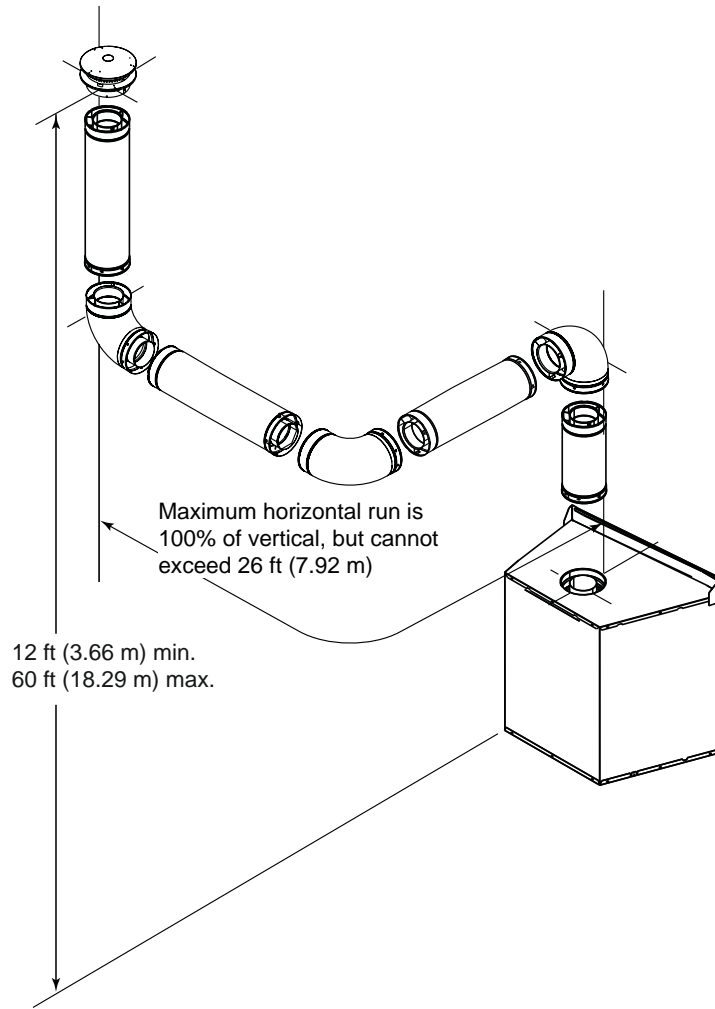

Figure 7.9



# 8 Vent Clearances and Framing

## A. Pipe Clearances to Combustibles

**WARNING! Risk of Fire! Maintain air space clearance to vent. DO NOT pack insulation or other combustibles:**

- Between ceiling firestops
- Between wall shield firestops
- Around vent system

Failure to keep insulation or other material away from vent pipe may cause over heating and fire.

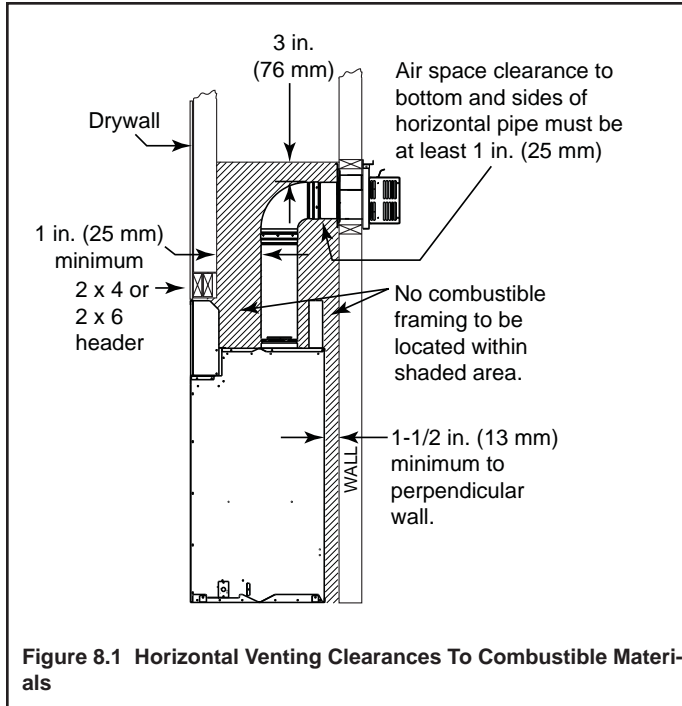

Figure 8.1 Horizontal Venting Clearances To Combustible Materials

## B. Wall Penetration Framing

### Combustible Wall Penetration

Whenever a combustible wall is penetrated, you must frame a hole for the wall shield firestop(s). The wall shield firestop maintains minimum clearances and prevents cold air infiltration.

- The opening must be framed on all four sides using the same size framing materials as those used in the wall construction.
- A wall shield firestop is required on one side only on interior walls. If your local inspector requires a wall shield firestop on both sides, then both wall shield firestops must have a heat shield attached to them.
- See Section 10.I. for information for regarding the installation of a horizontal termination cap.

### Non-Combustible Wall Penetration

If the hole being penetrated is surrounded by non-combustible materials such as concrete, a hole with diameter one inch greater than the pipe is acceptable.

Whenever a non-combustible wall is penetrated, the wall shield firestop is only required on one side and no heat shield is necessary.

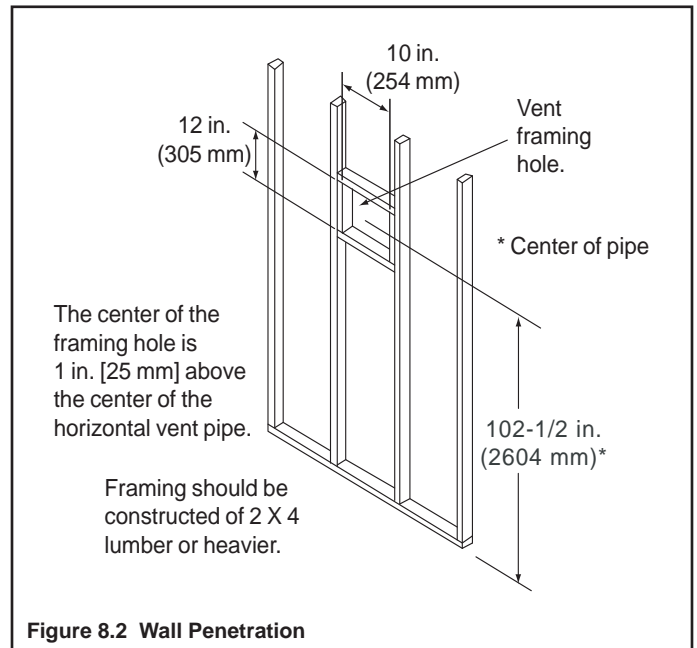

Figure 8.2 Wall Penetration

## C. Install the Ceiling Firestop

A ceiling firestop **MUST** be used between floors and attics.

- Frame an opening 10 in. by 10 in. (254 mm by 254 mm) whenever the vent penetrates a ceiling/floor (see Figure 8.3).
- Frame the area with the same sized lumber as used in ceiling/floor joist.
- The ceiling firestop may be installed above or below the ceiling joists when installed with a attic insulation shield. It must be under joists between floors that are not insulated. Refer to Figure 8.4.
- Secure with three fasteners on each side.

**WARNING! Risk of Fire! DO NOT pack insulation around the vent.** Insulation must be kept back from the pipe to prevent overheating.

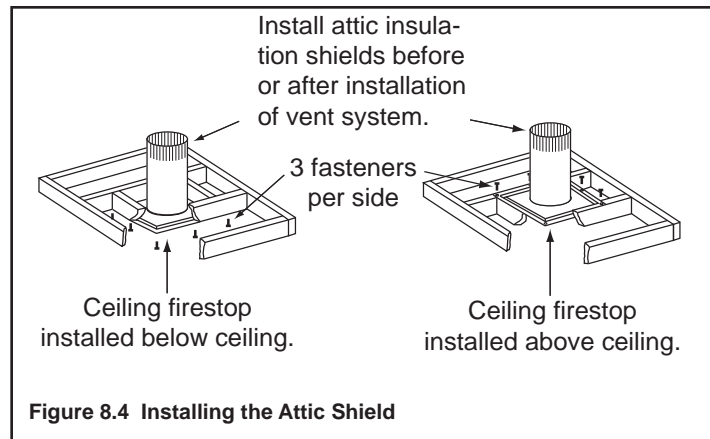
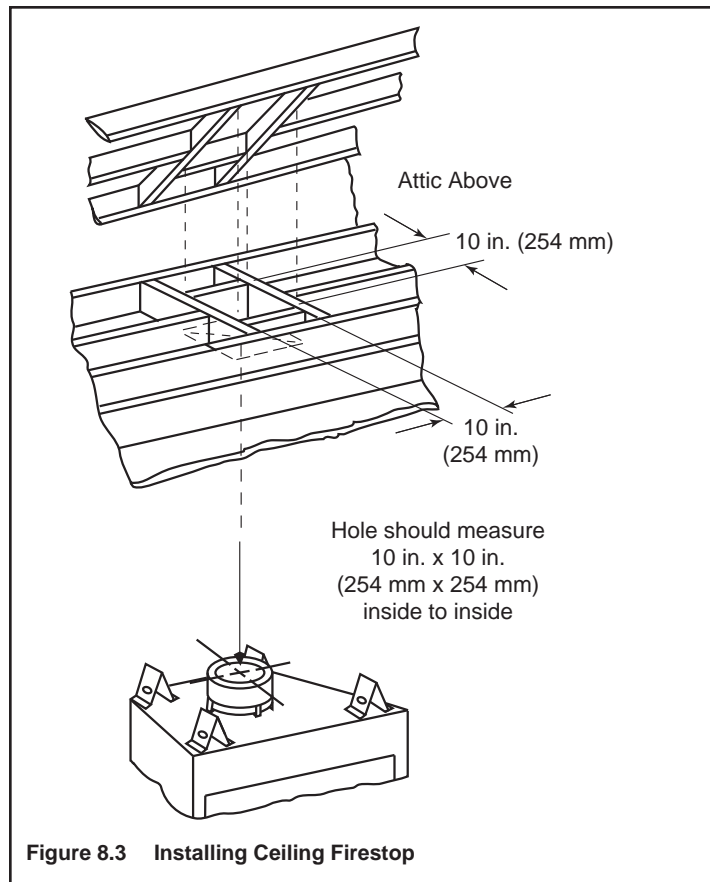

## D. Install Attic Insulation Shield

**WARNING! Fire Risk. DO NOT** allow loose materials or insulation to touch vent. Hearth & Home Technologies Inc. requires the use of an attic shield.

The National Fuel Gas Code ANSI Z223.1 and NFPA 54 requires an attic shield constructed of 26 gauge minimum metal that extends at least 2 in. (51 mm) above insulation.

Attic shields must meet specified clearance and be secured in place.

### Flat Ceiling Installation

- Remove one shield from box.

**NOTICE:** Cut previously installed batt insulation to make room for the attic insulation shield.

- Wrap shield around pipe if pipe is already installed in area to be insulated.
- Match the three holes in each side and fasten with three screws to form a tube.
- Bend three tabs on the bottom of the shield outward to allow attachment to the ceiling firestop.
- Bend the remaining bottom tabs inward 90° to maintain the air space between the pipe and the shield. Set the shield on the ceiling firestop and attach to the firestop.
- Bend all tabs inward 90° around the top of the shield. These tabs must be used to prevent blown insulation from getting between the shield and vent pipe, and to maintain air space clearance.

### Vaulted Ceiling Installation

- Remove one shield from box.

**NOTICE:** Cut previously installed batt insulation to make room for the attic insulation shield.

- Cut the attic insulation shield (if application is for vaulted ceiling), to fit your ceiling pitch. Snip cut edge to recreate 1 in. bend tabs all the way around the bottom.
- Wrap shield around pipe if pipe is already installed in area to be insulated.
- Match the three holes in each side and fasten with three screws to form a tube.
- Bend three tabs on the bottom of the shield outward to allow attachment to the ceiling firestop.
- Bend the remaining bottom tabs inward 90° to maintain the air space between the pipe and the shield. Set the shield on the ceiling firestop and attach to the firestop.
- Bend all tabs inward 90° around the top of the shield. These tabs must be used to prevent blown insulation from getting between the shield and vent pipe, and to maintain air space clearance.

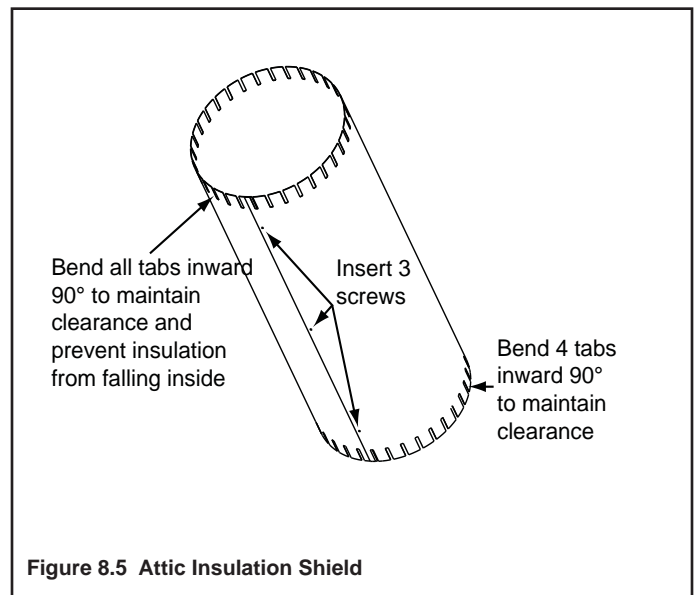

# 9 Appliance Preparation

## A. Secure and Level the Appliance

**WARNING! Risk of Fire!** Prevent contact with:

- Sagging or loose insulation
- Insulation backing or plastic
- Framing and other combustible materials

Block openings into the chase to prevent entry of blown-in insulation. Make sure insulation and other materials are secured.

**DO NOT** notch the framing around the appliance standoffs.

Failure to maintain air space clearance may cause overheating and fire.

The diagram shows how to properly position and secure the appliance (see Figure 9.1). Nailing tabs are provided to secure the appliance to the framing members.

- Bend out nailing tabs on each side.
- Place the appliance into position.
- Keep nailing tabs flush with the framing.
- Level the appliance from side to side and front to back.
- Shim the appliance as necessary. It is acceptable to use wood shims underneath the appliance.
- Secure the appliance to the framing by using nails or screws through the nailing tabs.
- Secure the appliance to the floor by inserting two screws through the pilot holes at the bottom of the appliance.

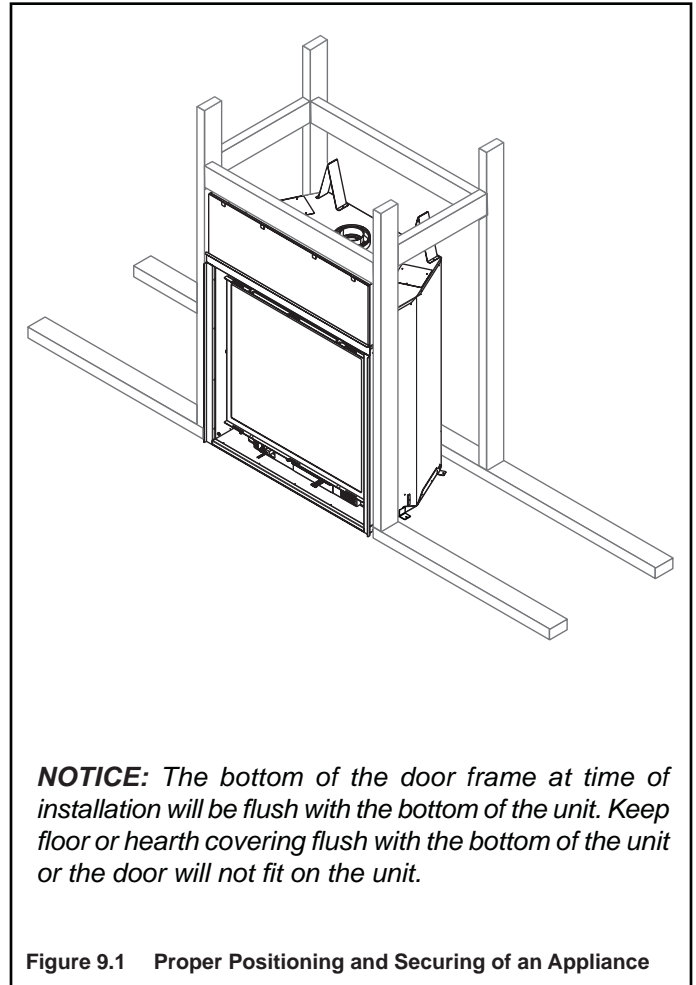

# 10 Install Vent Pipe

## A. Assemble Vent Sections

### Attach Pipe to the Firebox Assembly

**Note:** The end of the pipe sections with the lanced tabs will face towards the appliance.

Attach the first pipe section to the starting collar:

- Lanced pipe end to the starting collar
- Inner pipe over inner collar
- Push the pipe section until all lanced tabs snap in place
- Lightly tug on pipe to confirm it has locked.

### Commercial, Multi-family (Multi-level exceeding two stories), or High-Rise Applications

All outer pipe joints must be sealed with high temperature silicone (300° F minimum continuous exposure rating), including the slip section that connects directly to the horizontal termination cap.

- Apply a bead of silicone sealant inside the female outer pipe joint prior to joining sections. See Figure 10.1
- Only outer pipes need to be sealed. All unit collar, pipe, slip section, elbow and cap outer flues shall be sealed in this manner, unless otherwise stated.

**WARNING! Risk of Fire or Explosion! DO NOT break silicone seals on slip sections. Use care when removing termination cap from slip pipe. If slip section seals are broken during removal of the termination cap, vent may leak.**

### Assemble Pipe Sections

Per Figure 10.2:

- Start the inner pipe on the lanced end of section A into the flared end of section B.
- Start the outer pipe of section A over the outer pipe of section B.
- Once both vents sections are started, push firmly until all lanced tabs lock into place.
- Lightly tug on the pipe to confirm the tabs have locked.

It is acceptable to use screws no longer than 1/2 in. (13 mm) to hold outer pipe sections together. If predrilling holes, **DO NOT** penetrate inner pipe.

For 90° and 45° elbows that are changing the vent direction from horizontal to vertical, one screw minimum should be put in the outer flue at the horizontal elbow joint to prevent the elbow from rotating. Use screws no longer than 1/2 in. (13 mm). If predrilling screw holes, **DO NOT** penetrate inner pipe.

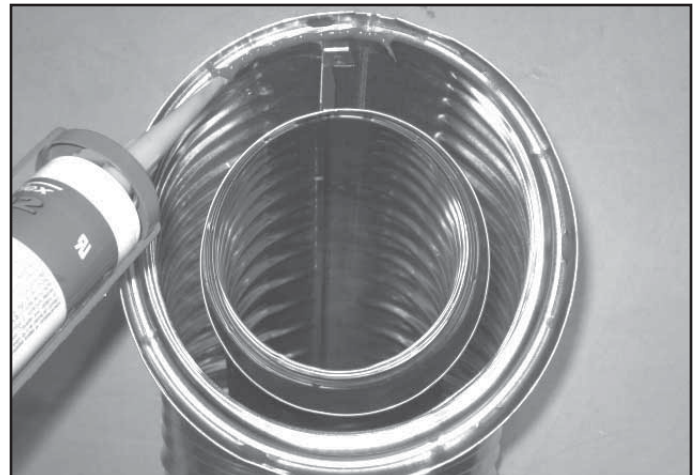

Figure 10.1 High Temperature Silicone Sealant

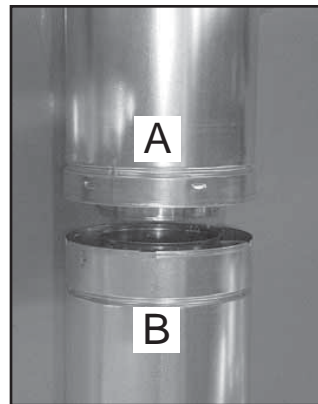

Figure 10.2

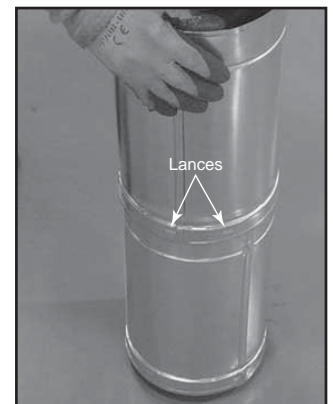

Figure 10.3

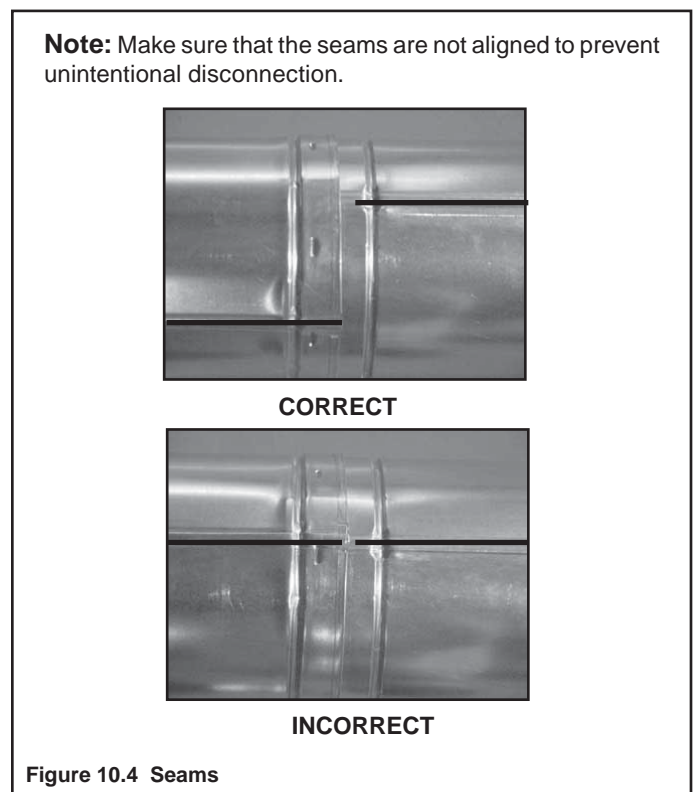

Figure 10.4 Seams

## B. Assemble Slip Sections

**WARNING! Risk of Fire or Asphyxiation!** Overlap pipe sections at least 1 1/2 in. (38 mm). Secure slip sections with two screws which must not exceed 1/2 in. (13 mm) in length. Use the pilot holes. Pipe could separate if not properly joined.

- Slide the inner flue of the slip section into the inner flue of the pipe section and the outer flue of the slip section over the outer flue of the pipe section. See Figure 10.5.
- Slide together to the desired length.

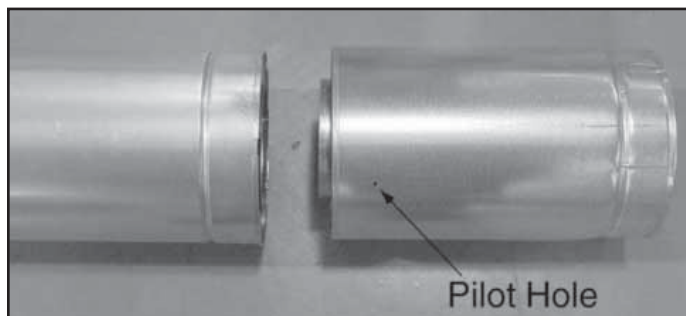

Figure 10.5 Slip Section Pilot Holes

- Maintain a 1-1/2 in. (38 mm) overlap between the slip section and the pipe section.
- Secure the pipe and slip section with two screws no longer than 1/2 in. (13 mm), using the pilot holes in the slip section. See Figure 10.6.

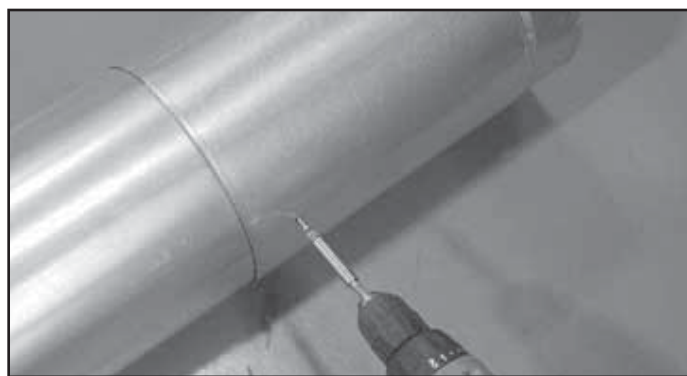

Figure 10.6 Screws into Slip Section

- Continue adding pipe as necessary following instructions in “Assemble Pipe Sections.”

**NOTICE:** If slip section is too long, the inner and outer flues of the slip section can be cut to the desired length.

**NOTICE:** When installing a vent system with an HRC termination cap, all pipe system joints shall be sealed using a high temperature silicone sealant (300° F minimum continuous exposure rating).

- Apply a bead of silicone sealant inside the female outer pipe joint prior to joining sections.
- Only outer pipes are sealed, sealing the inner flue is not required.
- All unit collar, pipe, slip section, elbow and cap outer flues shall be sealed.

### C. Secure the Vent Sections

- Vertical runs of pipe must be supported every 8 ft. (2.44 m) after the 25 ft. (7.62 m) maximum unsupported rise.
- Horizontal sections of vent must be supported every 5 ft. (1.52 m) with a vent support or plumber's strap.
- Wall shield firestops may be used to provide horizontal support.
- Vent support or plumber's strap (spaced 120° apart) may be used for support. See Figures 10.7 and 10.8.

**WARNING! Risk of Fire, Explosion or Asphyxiation!** Improper support may allow vent to sag and separate. Use vent run supports and connect vent sections per installation instructions. DO NOT allow vent to sag below connection point to appliance.

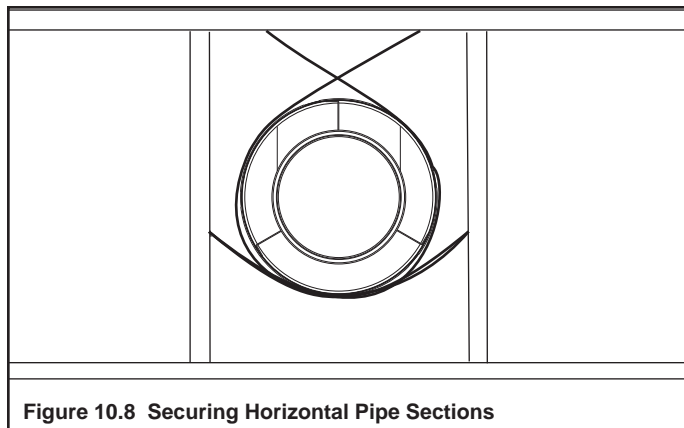
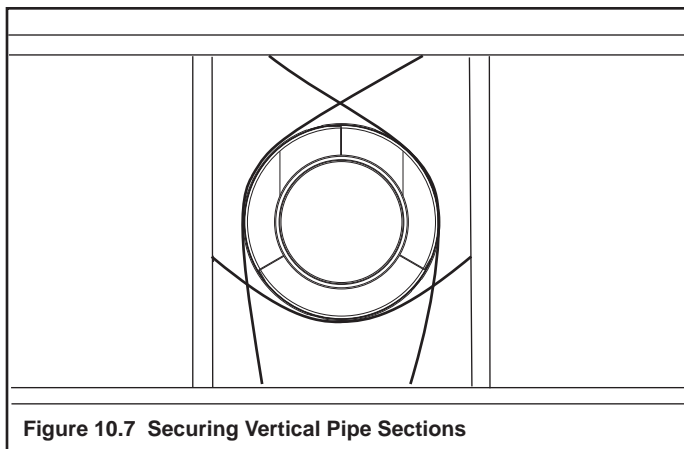

### D. Disassemble Vent Sections

- Rotate either section (see Figure 10.9) so the seams on both pipe sections are aligned as shown in Figure 10.10.
- Pull carefully to separate the pieces of pipe.

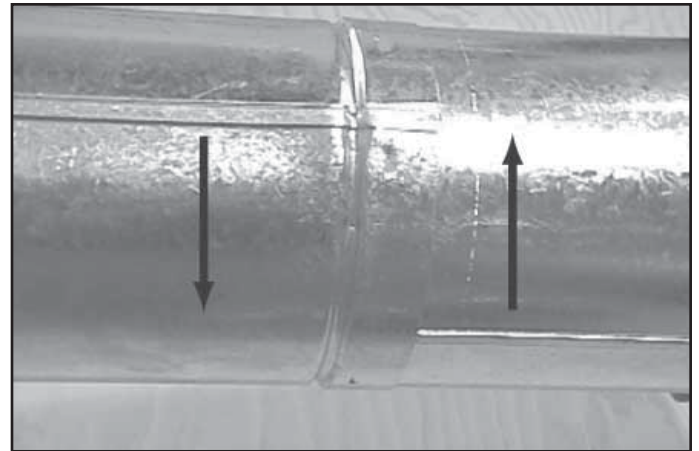

Figure 10.9 Rotate Seams for Disassembly

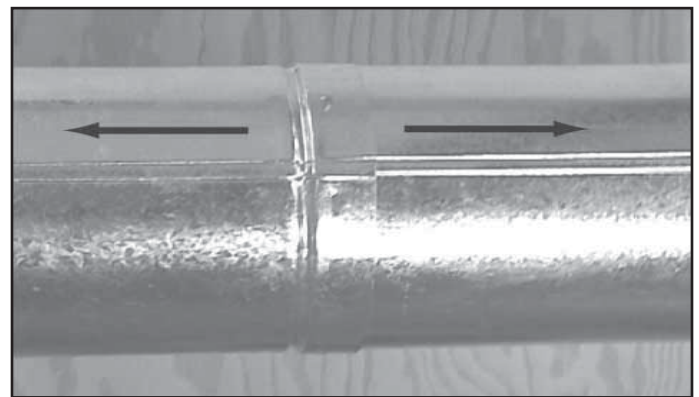
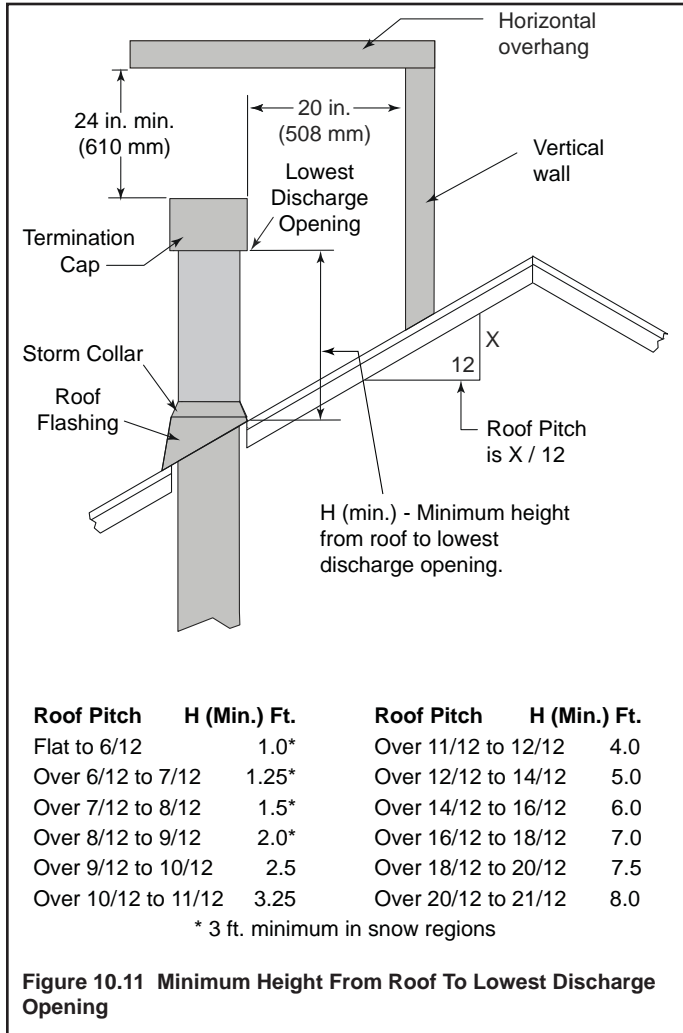

Figure 10.10 Align and Disassemble Vent Sections

## E. Install Metal Roof Flashing

- See minimum vent heights for various pitched roofs (Figure 10.11) to determine the length of pipe to extend through the roof.
- Slide the roof flashing over the pipe sections extending through the roof as shown in Figure 10.12.



**NOTICE:** Failure to properly caulk the roof flashing and pipe seams may permit entry of water.

- Caulk the gap between the roof flashing and the outside diameter of the pipe.
- Caulk the perimeter of the flashing where it contacts the roof surface. See Figure 10.15.
- Caulk the overlap seam of any exposed pipe sections that are located above the roof line.

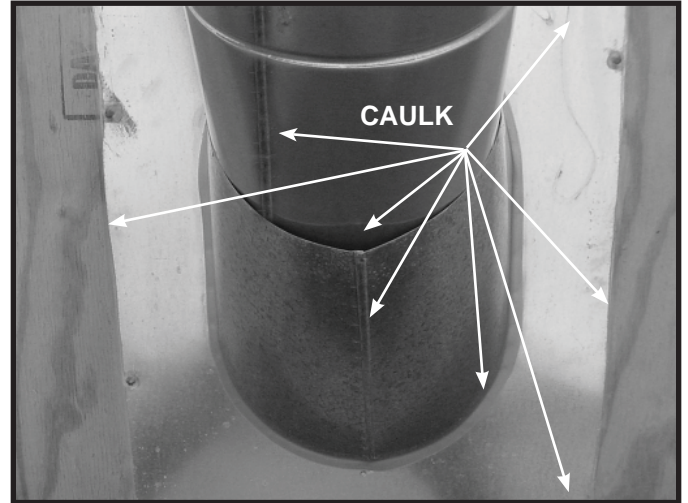

**Figure 10.12 Caulking**



## F. Assemble and Install Storm Collar

**CAUTION! Risk of Cuts, Abrasions or Flying Debris.**  
Wear protective gloves and safety glasses during installation. Sheet metal edges are sharp.

- Connect both halves of the storm collar with two screws (see Figure 10.13).
- Wrap the storm collar around the exposed pipe section closest to the roof and align brackets. Insert a bolt (provided) through the brackets and tighten the nut to complete the storm collar assembly (Figure 10.14). Make sure the collar is tight against the pipe section.
- Slide the assembled storm collar down the pipe section until it rests on the roof flashing.
- Caulk around the top of the storm collar (see Figure 10.20).

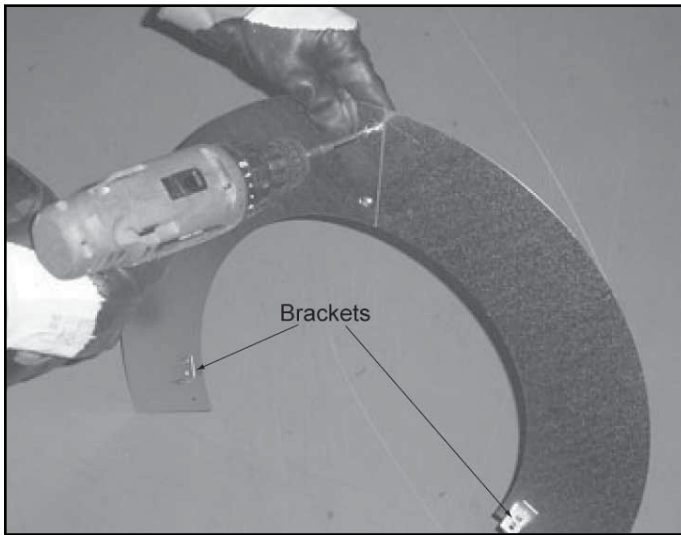

Figure 10.13 Assembling the Storm Collar



Figure 10.14 Assembling the Storm Collar Around the Pipe

## G. Install Vertical Termination Cap

- Attach the vertical termination cap by sliding the inner collar of the cap into the inner flue of the pipe section while placing the outer collar of the cap over the outer flue of the pipe section.
- Secure the cap by driving three self-tapping screws (supplied) through the pilot holes in the outer collar of the cap into the outer flue of the pipe (see Figure 10.15).

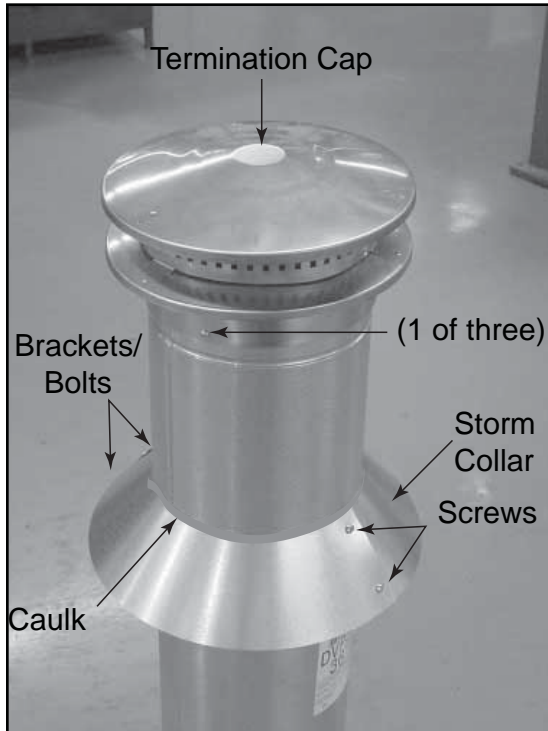

Figure 10.15 Install Vertical Termination Cap

## H. Heat Shield Requirements for Horizontal Termination

**WARNING! Risk of Fire!** To prevent overheating and fire, heat shields must extend through the entire wall thickness.

- **DO NOT** remove the heat shields attached to the wall shield firestop and the horizontal termination cap.
- Heat shields must overlap 1-1/2 in. (38 mm) minimum.

There are two sections of the heat shield. One section is factory-attached to the wall shield firestop. The other section is factory-attached to the cap. See Figure 10.16.

If the wall thickness does not allow the required 1-1/2 in. (38 mm) heat shield overlap when installed, an extended heat shield must be used.

- If the wall thickness is less than 4 in./102 mm the heat shields on the cap and wall shield firestop must be trimmed. A minimum 1-1/2 in. (38 mm) overlap MUST be maintained.
- Use an extended heat shield if the finished wall thickness is greater than 7-1/4 in. (184 mm).
- The extended heat shield may need to be cut to length maintaining sufficient length for a 1-1/2 in. (38 mm) overlap between heat shields.
- Attach the extended heat shield to either of the existing heat shields using the screws supplied with the extended heat shield. Refer to "Vent Components Diagrams" in the back of this manual.
- Rest the small leg on the extended heat shield on top of the pipe section to properly space it from the pipe section.

**Important Notice:** Heat shields may not be field constructed.

## I. Install Horizontal Termination Cap

**WARNING! Risk of Fire!** The telescoping flue section of the termination cap **MUST** be used when connecting vent.

- 1-1/2 (38 mm) minimum overlap of flue telescoping section is required.

Failure to maintain overlap may cause overheating and fire.

- Vent termination must not be recessed in the wall. Siding may be brought to the edge of the cap base.
- Flash and seal as appropriate for siding material at outside edges of cap.

- When installing a horizontal termination cap, follow the cap location guidelines as prescribed by current **ANSI Z223.1** and **CAN/CGA-B149** installation codes and refer to Section 6 of this manual.

**CAUTION! Risk of Burns!** Local codes may require installation of a cap shield to prevent anything or anyone from touching the hot cap.

**NOTICE:** For certain exposures which require superior resistance to wind-driven rain penetration, a flashing kit and HPC caps are available. When penetrating a brick wall, a brick extension kit is available for framing the brick.

**Note:** When using termination caps with factory-supplied heat shield attached, no additional wall shield firestop is required on the exterior side of a combustible wall.

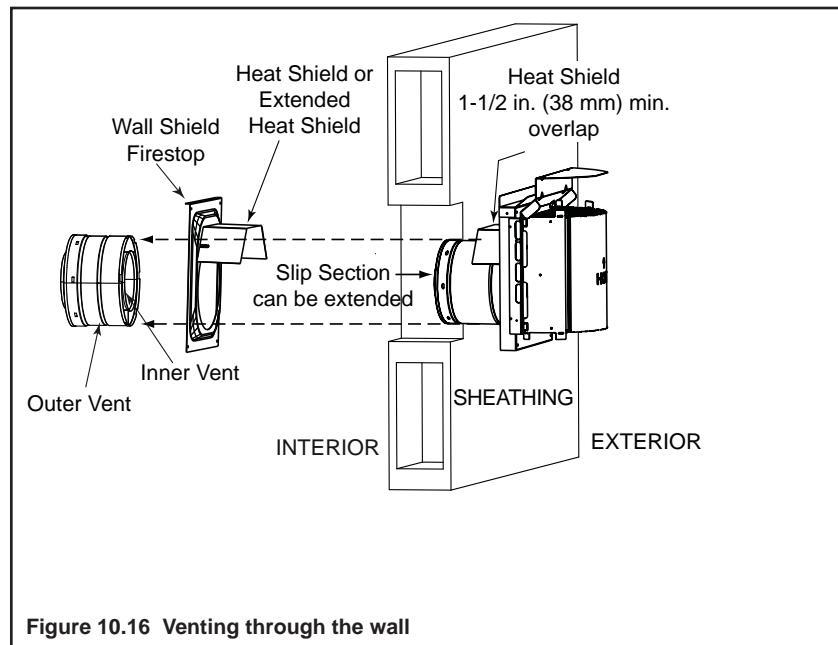

# 11 Shrouds

## A. HHT Shrouds

- You may install a shroud with this fireplace. See Section 17.D. for a list of UL Listed shrouds. Follow the instructions included with these optional components

## B. Field Constructed Shrouds

**WARNING! Risk of Fire!** Shrouds must be constructed as specified. Improper construction may overheat chase top.

- Chase top shrouds may be field constructed where permitted by regional building codes.

**NOTICE:** Some regional codes require an agency-Listed shroud. Consult your local building officials.

- The following field constructed shroud designs have been tested for Hearth Technologies fireplace systems and termination caps.
- The shrouds must be constructed from a minimum .018 in. (26 ga) thick aluminized steel.
- The wire mesh is optional but recommended and must be .018 in. thick minimum, 1/2 in. mesh.

### Open Top Shroud (may be used with DVP-TV, DVP-TVHW, SLP-TVHW)

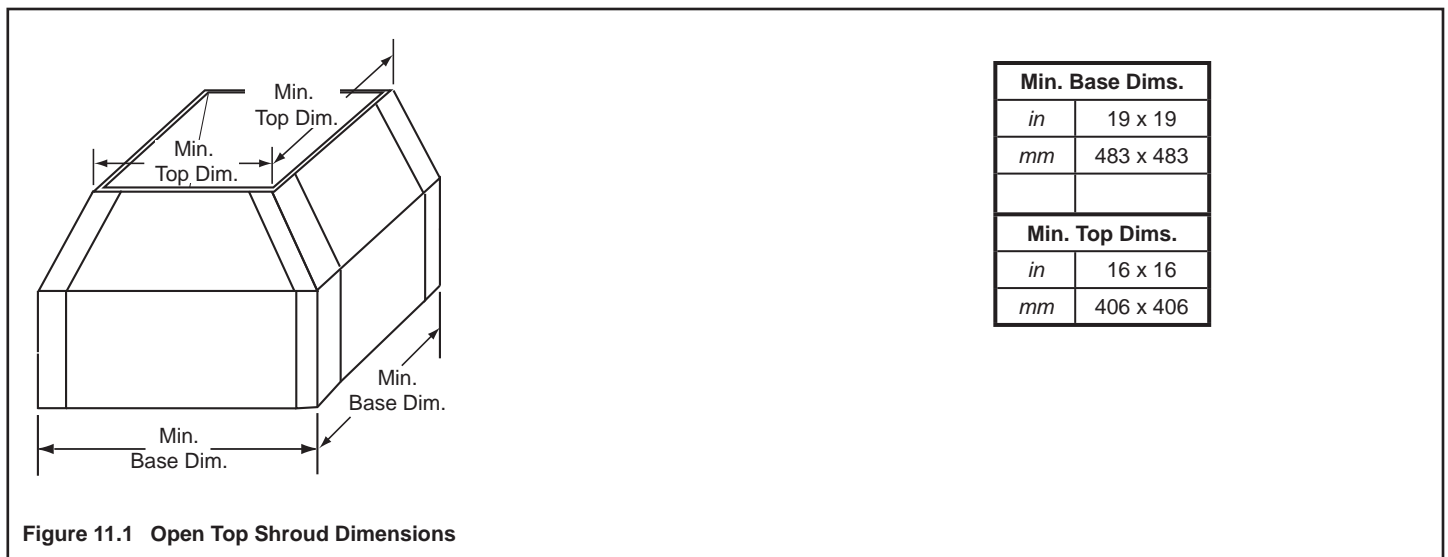

**Mailbox Style Shroud (may be used with DVP-TV, DVP-TVHW, SLP-TVHW)**

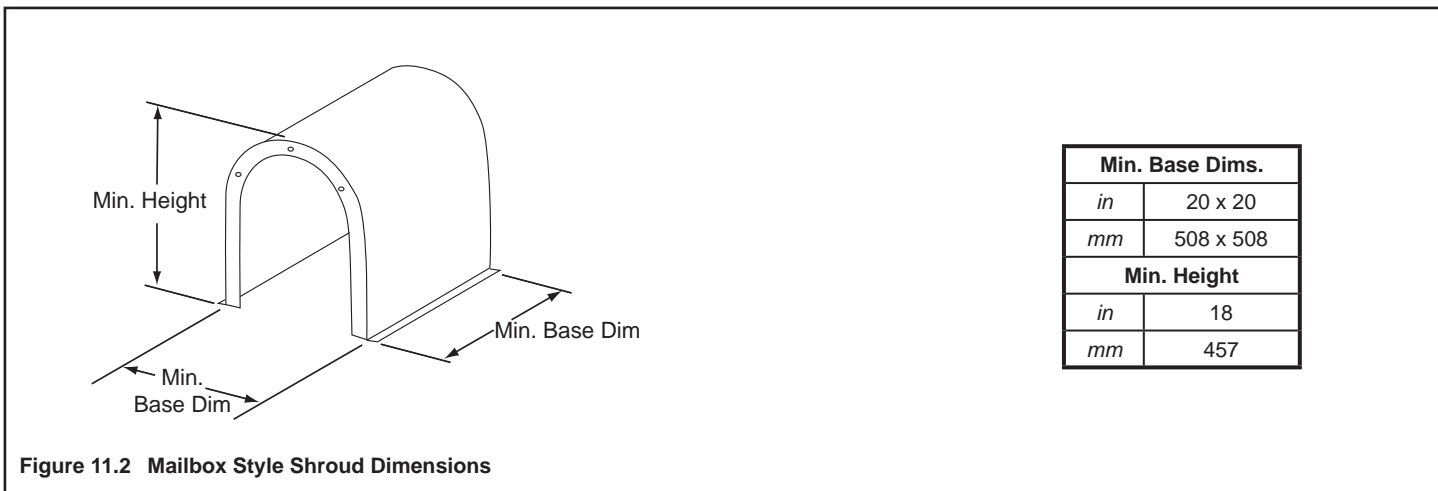

**Roofed Style Shroud (may be used with DVP-TV, DVP-TVHW, SLP-TVHW)**

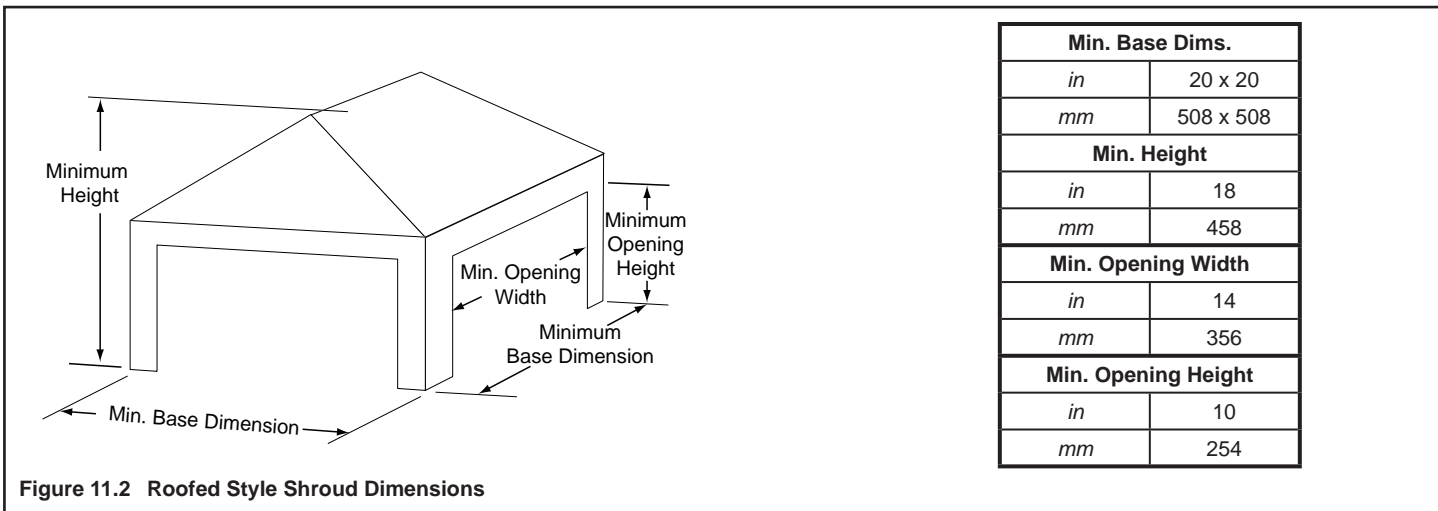

# 12 Gas Information

## A. Fuel Conversion

- Make sure the appliance is compatible with available gas types.
- Conversions must be made by a qualified service technician using Hearth & Home Technologies specified and approved parts.

### Converting to LP Gas

**Note:** Gas conversions should only be performed by a qualified service person, and/or where required by state and local codes, licensed installer/service technician. In the Commonwealth of Massachusetts, installation must be performed by a licensed plumber or gas fitter.

#### Kit contents:

Pilot injector #35  
Burner orifice  
Red pin  
Conversion Label

#### Tools Required:

#2 phillips screwdriver  
Straight screwdriver  
5/32 allen wrench  
3/8 & 11/16 wrenches

- Turn control knob on the valve to OFF position.
- Remove glass assembly (see Figure 15.A)
- (Remove logs, grate, and ember bed if already installed.)
- Remove 2 screws holding pilot bracket to burner. See Figure 11.1.

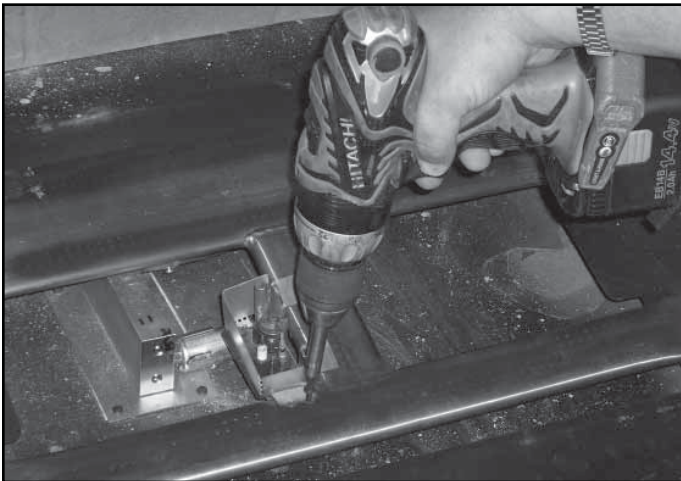

Figure 12.1 Remove Pilot Screws

- Remove 4 screws holding Burner in place and remove burner. See Figure 12.2.

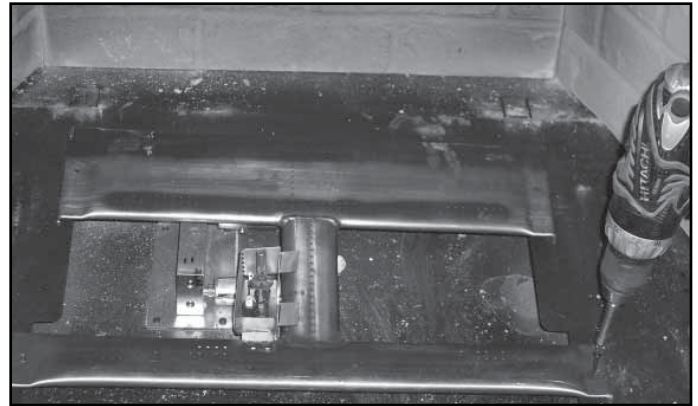

Figure 12.2 Remove Burner Screws

- Using a 3/8 wrench, unscrew and remove rear orifice and discard. See Figure 12.3.

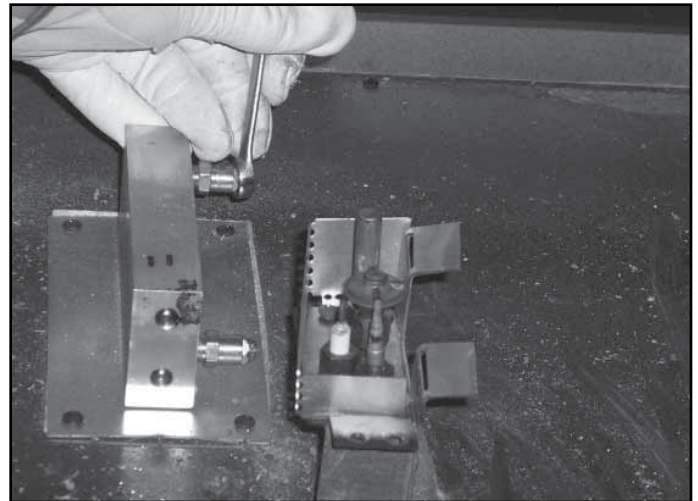

Figure 12.3 Remove Burner Orifice

- Unscrew and remove front orifice #46 and install in rear.
- Install new orifice #56 in front.
- Open air shutters to fully open. See Figure 12.4.
- Replace burner and screws holding it in place.



Figure 12.4 Adjusting Air Shutter

- Replace 2 screws holding pilot bracket to burner.
- Pull hood keeper from pilot and lift hood off pilot assembly. See Figure 12.5.

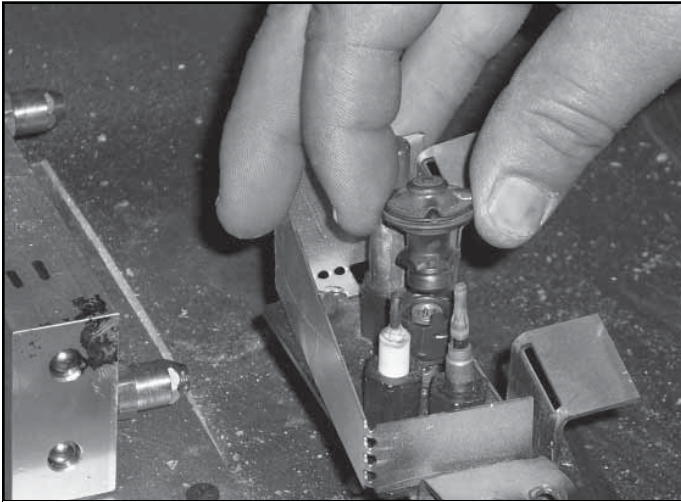

Figure 12.5 Remove Pilot Hood

**Note:** Do not remove retaining clip from the hood.

- Remove #62 pilot injector using 5/32 allen wrench and replace with #35 LP orifice.

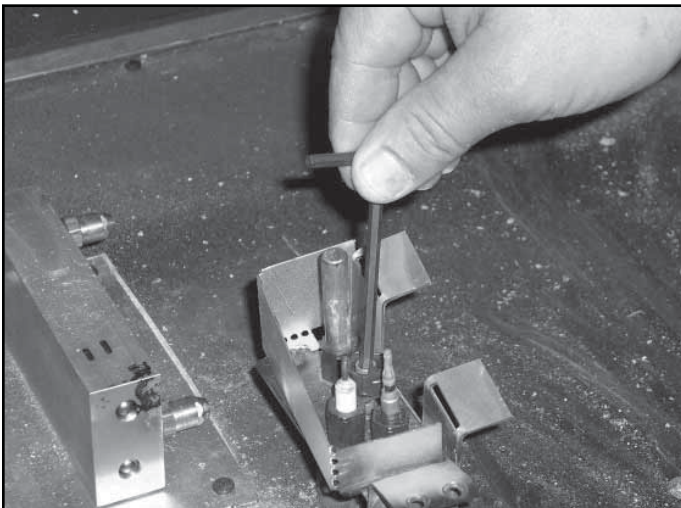

Figure 12.6 Remove Pilot Injector

- Replace hood and keeper.
- Loosen locknut on the Hi-Lo Solenoid using 11/16 wrench.
- Remove solenoid from the valve by turning counterclockwise.
- Use a screwdriver and turn pressure screw clockwise 3/4 turn.
- Attach manometer to outlet side of the valve.
- Light unit.
- Fine tune pressure with screwdriver.
- Replace the blue pin with the red pin and screw solenoid onto the valve.
- Continue turning solenoid until pressure is 10.
- Tighten locknut on the Solenoid so it will not loosen.
- Install identification label near the valve. See Figure 12.8.

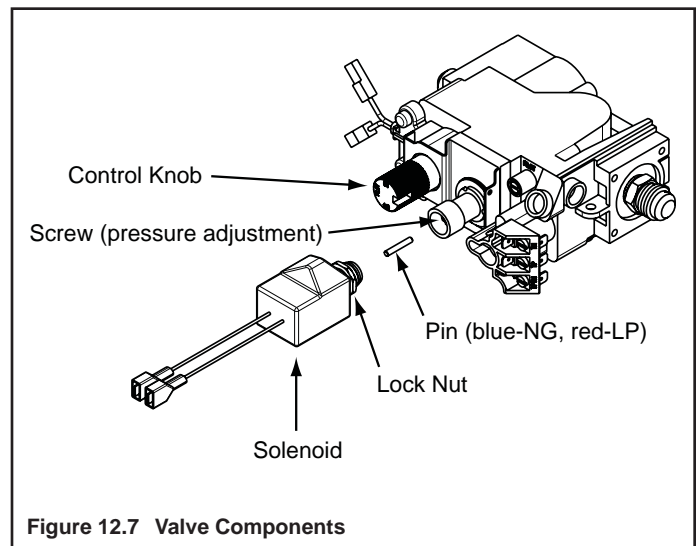

Figure 12.7 Valve Components

44CKP	44CKN
<p>THIS PLATE MUST BE AFFIXED AS CLOSE AS POSSIBLE TO THE EXISTING RATING PLATE.</p> <p>THE FOLLOWING MUST BE COMPLETED BY THE INDIVIDUAL CONVERTING THIS APPLIANCE:</p> <p>THIS APPLIANCE HAS BEEN CONVERTED TO _____ FUEL,            FRONT ORIFICE _____, REAR ORIFICE _____,            MANIFOLD PRESSURE _____, AND INPUT _____, ON _____ (date),            WITH KIT # 44CKP; 44CKN (circle one), BY (name &amp; address of organization making this conversion)</p> <p>_____</p> <p>_____</p> <p>_____</p>	
<p>WHO ACCEPTS THE RESPONSIBILITY FOR THE CORRECTNESS OF THIS CONVERSION.</p> <p style="text-align: right;">4051-304B ←</p>	

Figure 12.8 Identification Label

## B. Gas Pressure

- Optimum appliance performance requires proper input pressures.
- Gas line sizing requirements will be determined in ANSI Z221.3 National Fuel Gas Code in the USA and CAN/CGA B149 in Canada.
- Pressure requirements are:

Gas Pressure	Natural Gas	Propane
Minimum inlet pressure	5.0 in. w.c.	11.0 in. w.c.
Maximum inlet pressure	10.0 in. w.c.	13.0 in. w.c.
Manifold pressure	3.5 in. w.c.	10.0 in. w.c.

**WARNING! Risk of Fire or Explosion! High pressure will damage valve. Low pressure may cause explosion.**

- Verify inlet pressures. Verify minimum pressures when other household gas appliances are operating.
- Install regulator upstream of valve if line pressure is greater than 1/2 psig.

**⚠ WARNING**



Fire Risk.  
Explosion Hazard.  
High pressure will damage valve.

- Disconnect gas supply piping BEFORE pressure testing gas line at test pressures above 1/2 psig.
- Close the manual shutoff valve BEFORE pressure testing gas line at test pressures equal to or less than 1/2 psig.

**Note:** Have the gas supply line installed in accordance with local codes, if any. If not, follow ANSI 223.1. Installation should be done by a qualified installer approved and/or licensed as required by the locality. (In the Commonwealth of Massachusetts installation must be performed by a licensed plumber or gas fitter).

**Note:** A listed (and Commonwealth of Massachusetts approved) 1/2 in. (13 mm) T-handle manual shut-off valve and flexible gas connector are connected to the 1/2 in. (13 mm) control valve inlet.

- **If substituting for these components, please consult local codes for compliance.**

## C. Gas Connection

- Refer to Reference Section 17.A. for location of gas line access in appliance.
- Gas line may be run through knockout provided on the left side only.
- The gap between supply piping and gas access hole may be caulked with caulk with a minimum of 300° F continuous exposure rating or stuffed with non-combustible, unfaced insulation to prevent cold air infiltration.
- Ensure that gas line does not come in contact with outer wrap of the appliance. Follow local codes.
- Pipe incoming gas line into valve compartment.
- Connect incoming gas line to the 1/2 in. (13 mm) connection on manual shutoff valve.

**WARNING! Risk of Fire or Explosion! Support control when attaching pipe to prevent bending gas line.**

- A small amount of air will be in the gas supply lines.

**WARNING! Risk of Fire or Explosion! Gas build-up during line purge could ignite.**

- Purge should be performed by qualified service technician.
- Ensure adequate ventilation.
- Ensure there are no ignition sources such as sparks or open flames.

Light the appliance. It will take a short time for air to purge from lines. When purging is complete the appliance will light and operate normally.

**WARNING! Risk of Fire, Explosion or Asphyxiation! Check all fittings and connections with a non-corrosive commercially available leak-check solution. DO NOT use open flame. Fittings and connections could have loosened during shipping and handling.**

**WARNING! Risk of Fire! DO NOT change valve settings. This valve has been preset at the factory.**

## D. High Altitude Installations

**NOTICE:** If the heating value of the gas has been reduced, these rules do not apply. Check with your local gas utility or authorities having jurisdiction.

When installing above 2000 feet elevation:

- In the USA: Reduce burner orifice 4% for each 1000 feet above 2000 feet.
- In CANADA: Reduce burner orifice 10% for elevations between 2000 feet and 4500 feet. Above 4500 feet, consult local gas utility.



# 13 Electrical Information

---

## A. Wiring Requirements

**NOTICE:** This appliance must be electrically wired and grounded in accordance with local codes or, in the absence of local codes, with **National Electric Code ANSI/NFPA 70-latest edition** or the **Canadian Electric Code CSA C22.1**.

- Wire the appliance junction box to 110-120 VAC. This is required for use of optional accessories.
- A 110-120 VAC circuit for this product must be protected with ground-fault circuit-interrupter protection, in compliance with the applicable electrical codes, when it is installed in locations such as in bathrooms or near sinks.
- Low voltage and 110 VAC voltage cannot be shared within the same wall box.

**WARNING! Risk of Shock or Explosion! DO NOT wire 110V to the valve or to the appliance wall switch. Incorrect wiring will damage controls.**

## B. Standing Pilot Ignition System Wiring

- The standing pilot ignition system wiring does not require a 110 VAC supply to operate.
- A 110 VAC junction box **MUST** be installed for use with a fan or remote control. See Figure 13.2 for junction box wiring. Keep wire lengths short as possible.

**NOTICE: DO NOT wire 110 VAC to the millivolt valve! This will damage the valve.**

- If using a thermostat use one compatible with a millivolt gas valve system:
  - Install the thermostat in the location as indicated in the thermostat instructions to ensure proper operation of appliance.
  - Use low resistance thermostat wire for wiring from ignition system to the wall switch and thermostat.
  - Keep wire lengths short as possible.

## C. Optional Accessories Requirements

- This appliance may be used with a wall switch, wall mounted thermostat and/or a remote control.

Wiring for optional Hearth & Home Technologies approved accessories should be done now to avoid re-construction. Follow instructions that come with those accessories.

## D. Electrical Service and Repair

**WARNING! Risk of Shock!** Label all wires prior to disconnection when servicing controls. Wiring errors can cause improper and dangerous operation. Verify proper operation after servicing.

**WARNING! Risk of Shock!** Replace damaged wire with type 105° C rated wire. Wire must have high temperature insulation.

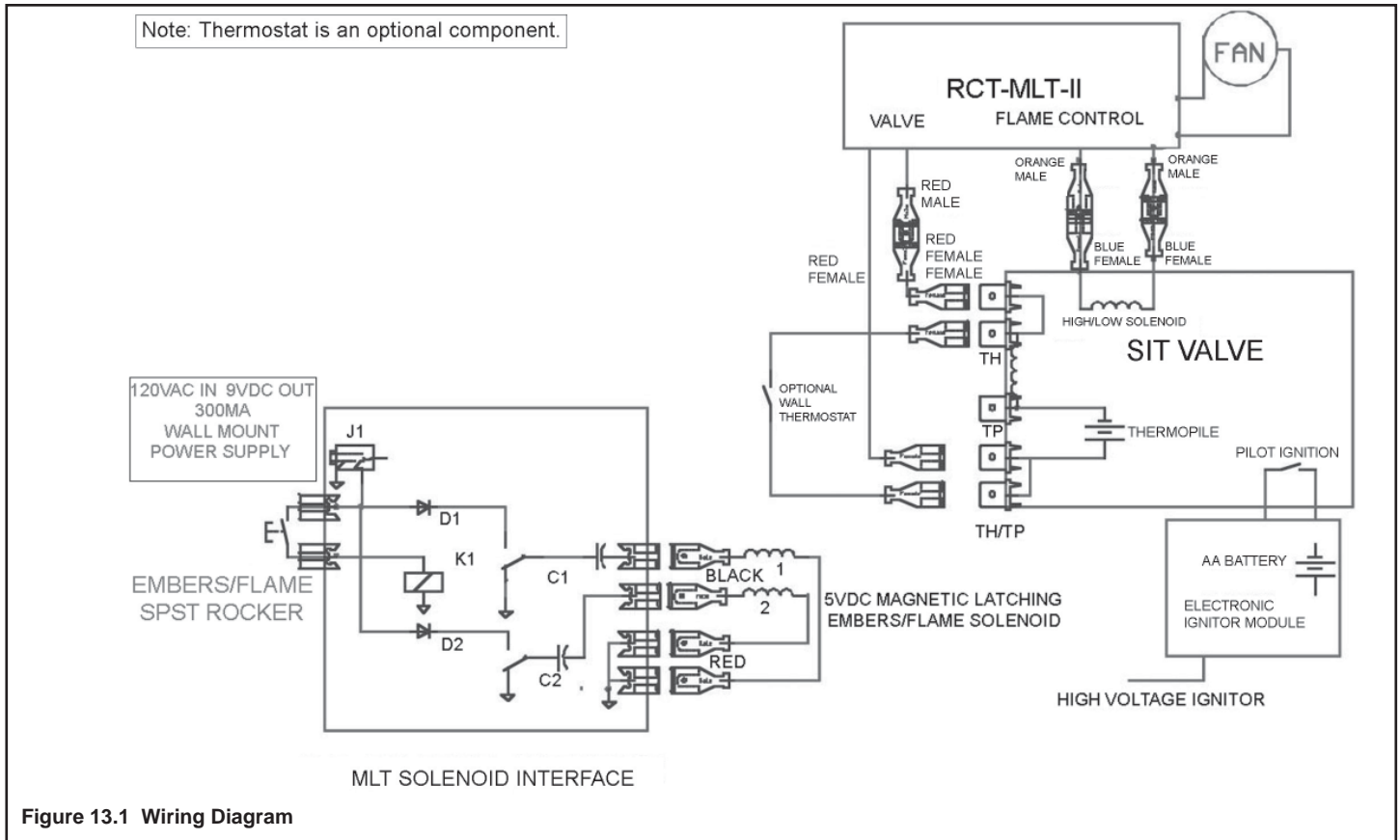

## E. Junction Box Installation

If the box is being wired from the **OUTSIDE** of the appliance:

- Remove the cover plate located on the outer shell - right side (see Figure 13.2).
- Install the supplied Romex™ connector in the cover plate.
- Feed the necessary length of wire through the connector.
- Make all necessary wire connections and reattach the cover plate to the outer shell.

If the box is being wired from the **INSIDE** of the appliance:

- Remove the screw attaching the junction box/receptacle to the outer shell, rotate the junction box inward to disengage it from the outer shell.
- Pull the electrical wires from outside the appliance through this opening into the valve compartment.
- Feed the necessary length of wire through the connector.
- Make all necessary wire connections to the junction box/receptacle and reassemble the junction box/receptacle to the outer shell.

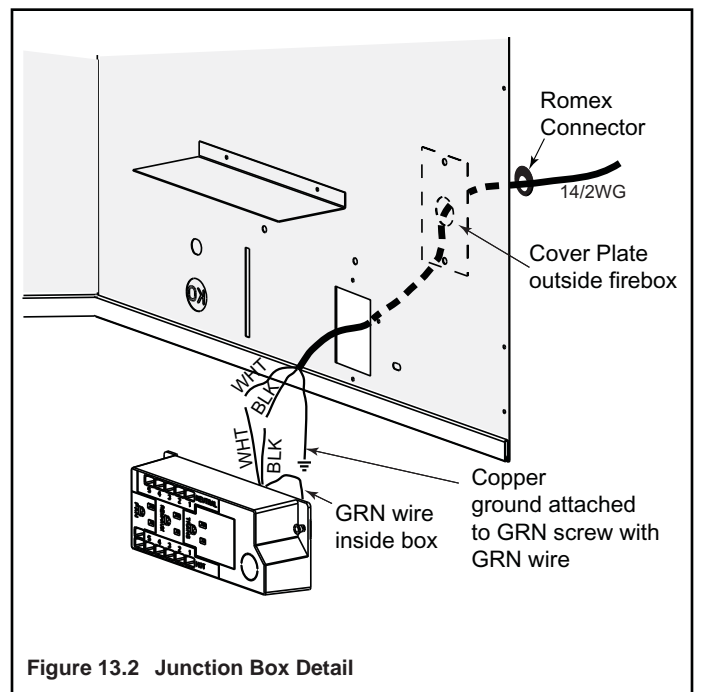

# 14 Finishing

## A. Mantel and Wall Projections

**WARNING! Risk of Fire!** Comply with all minimum clearances to combustibles as specified. Framing or finishing material closer than the minimums listed must be constructed entirely of non-combustible materials (i.e., steel studs, concrete board, etc).

### Mantels

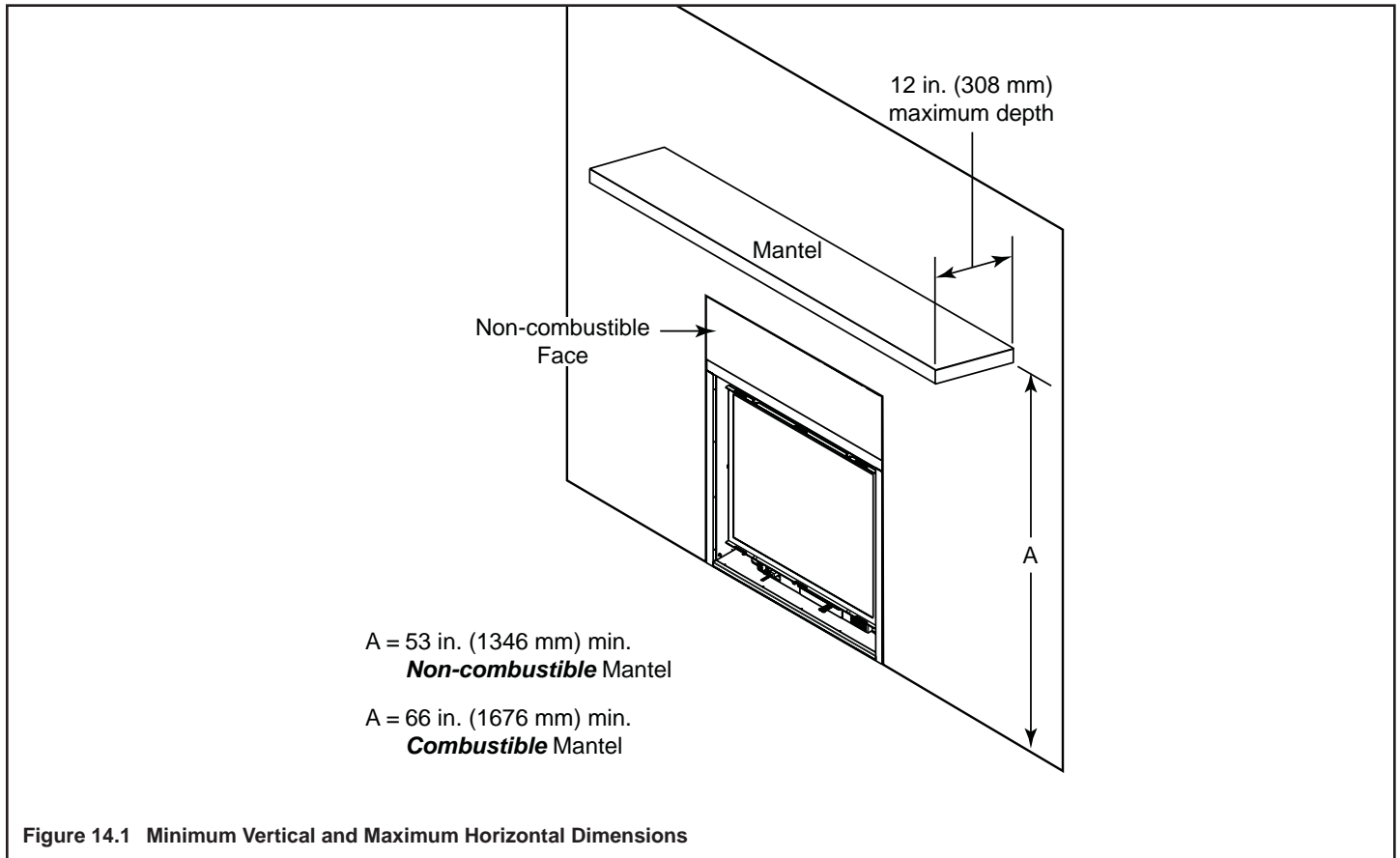

Figure 14.1 Minimum Vertical and Maximum Horizontal Dimensions

### Mantel Legs or Wall Projections

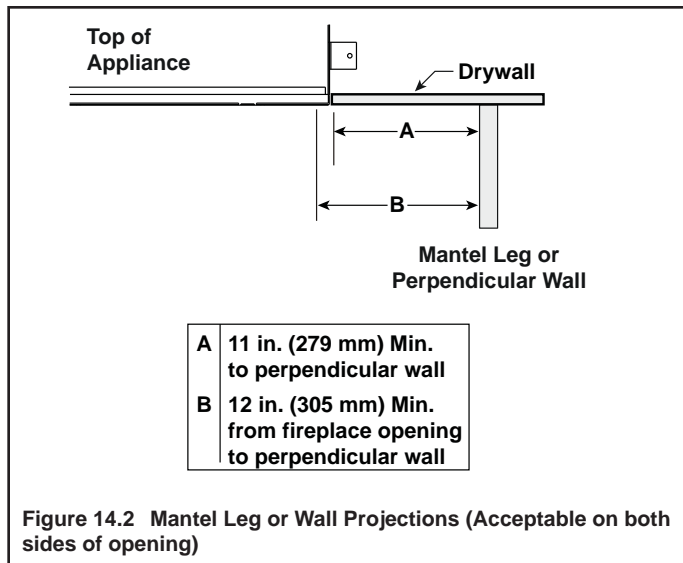

Figure 14.2 Mantel Leg or Wall Projections (Acceptable on both sides of opening)

## B. Facing Material

- The QFP44 is shipped with non-combustible material in place. Do not cover or replace this non-combustible material with combustible materials.
  - The non-combustible front upper can be removed if replaced with non-combustible materials. See Section 1.E. for materials that may be used.
- Combustible finish wall material may be butted up to the unit and the supplied non-combustible material of the upper front.
  - The unit is shipped with door templates attached. The wall material should go behind the templates and butt up to the edge of the unit. Refer to Figure 14.4.
- The joints at the non-combustible material may be taped and covered with normal joint compound.
- Seal joints between the finished wall and appliance top and sides using a 300 °F minimum sealant. Refer to Figure 14.3.

**WARNING! Risk of Fire! DO NOT** apply combustible materials beyond the minimum clearances. Comply with all minimum clearances to combustibles as specified in this manual. Overlapping materials could ignite and will interfere with proper operation of doors and louvers.

- Sheetrock/wall material will have been installed (see Figure 14.3) and the joints filled..
- If installing doors with an **outside surface fit**, the facing templates should be removed (retain the screws for door installation) and non-combustible facing material less than one inch thick may be brought to the edge of the fireplace opening. Doors will be mounted over the facing material. The door frame is slotted to allow the door to be mounted up to one inch from the surface of the unit.
- If installing doors with a **recessed fit**, facing material must be butted to the flanges of the facing templates to allow doors to fit within the facing material. Once the facing material is in place, the template must be removed (retain the screws for door installation).

## C. Facing Template Removal

There is a metal template on each side and across the top of the door opening. See Figure 14.4. If using an inside fit for the doors, do not remove the templates until the facing material is installed. If you choose to use an outside fit, the templates may be removed before installing the facing material.

- Side Templates – Remove the screws from the sides of the door opening and set aside. Remove and discard the template pieces.
- Top Template – Loosen the screws across the top of the opening. Slide the top template out, discard the template and tighten the screws.

## D. Mantel

The mantel may be constructed with combustible or non-combustible materials as indicated in Figure 14.5

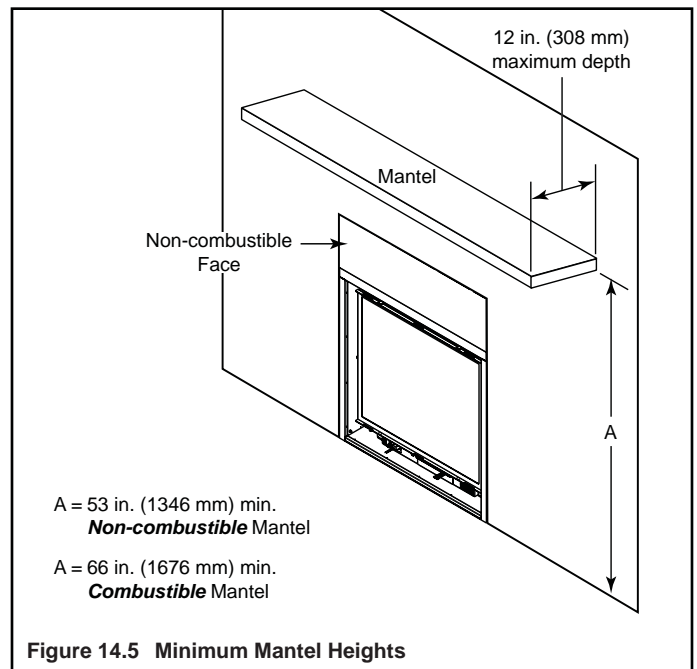
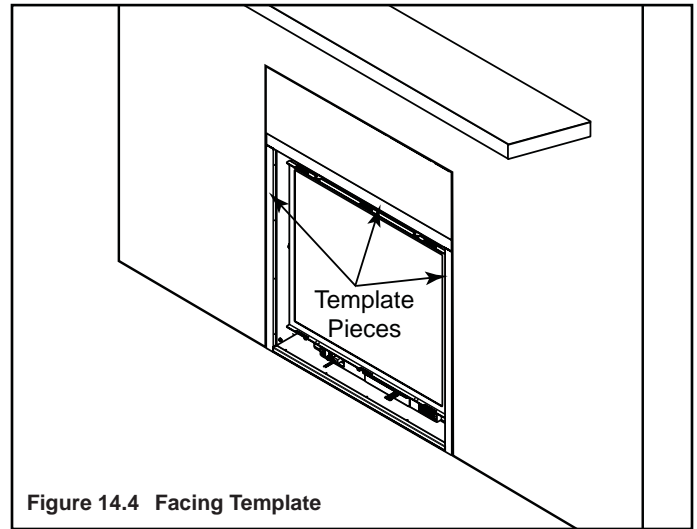
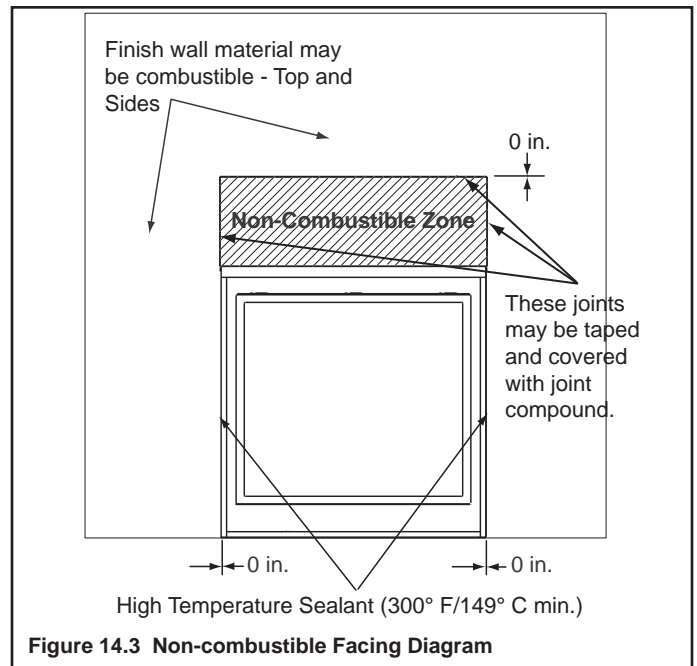

# 15 Appliance Setup

**WARNING! Risk of Fire and Electric Shock!** Use **ONLY** Hearth & Home Technologies-approved optional accessories with this appliance. Using non-listed accessories could result in a safety hazard and will void the warranty.

## A. Remove Glass Assembly

**WARNING! Risk of Asphyxiation!** Handle fixed glass assembly with care. Inspect the gasket to ensure it is undamaged and inspect the glass for cracks, chips or scratches.

- **DO NOT** strike, slam or scratch glass.
- **DO NOT** operate fireplace with glass removed, cracked, broken or scratched.
- Replace as a complete assembly.

The glass assembly can be removed from the unit by pulling and releasing the glass latches. There are three across the top, three across the bottom, and one in the center of each side.

The glass assembly is heavy. Use caution when removing.

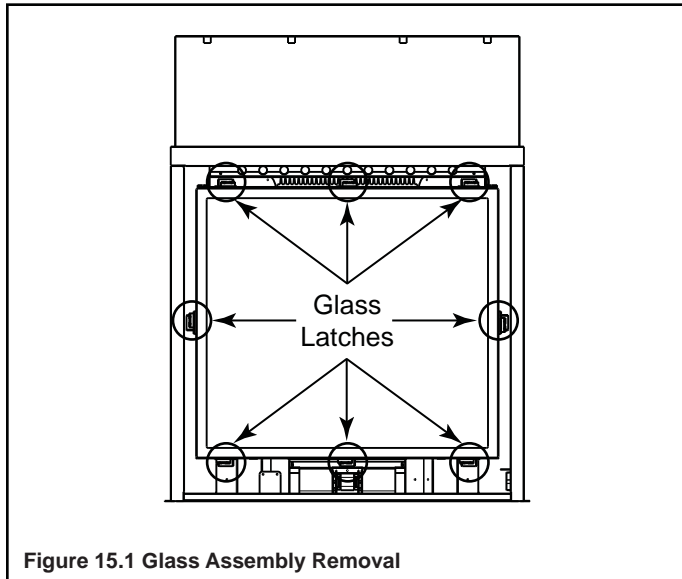

## B. Clean the Appliance

Clean/vacuum any sawdust that may have accumulated inside the firebox or underneath in the control cavity.

## C. Install the Refractory

- Remove the refractory retainer from each side of the firebox.
- Put the left side refractory in place and reinstall the left side refractory retainer.

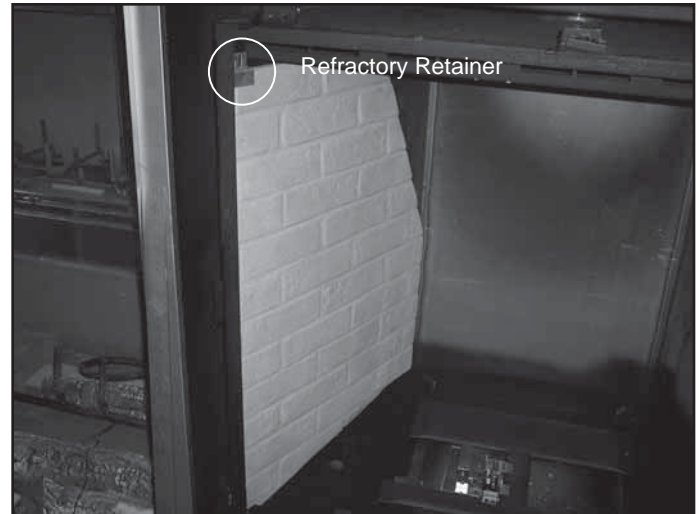

Figure 15.2 Install Left Side Refractory

- Install the lower back refractory.



Figure 15.3 Install Lower Back Refractory

- Install the upper back refractory.



Figure 15.4 Install Upper Back Refractory

- Install the right side refractory.
- Slide the back refractory slightly from side to side as necessary to close up any gaps in the corners.
- Install the right side refractory retainer.



Figure 15.5 Install Right Side Refractory

**Note:** As you use the appliance, expansion and contraction will cause minor cracking of the refractory. This is normal, unavoidable, and will not affect the performance of the appliance. If the cracks become large enough that the metal behind the refractory is exposed or large pieces fall out, the panels should be replaced.

#### D. Adjust the Air Shutter

This appliance has adjustable air shutters (which control the primary air) factory set in the closed position (approximately 1/8 in. open). See Figure 15.6.

**NOTICE:** If sooting occurs, provide more air by opening the air shutter.



Figure 15.6 Adjusting the Air Shutter

**IMPORTANT!** This appliance should be run three to four hours on low on the initial start-up. Turn it off and let it cool completely. Remove and clean the glass. Reinstall the glass and run the appliance for an additional 12 hours. This will help cure the products used in the paint and logs.

## E. Adjust the Vertical Baffle

If the vertical run height is more than 12 feet, it may be necessary to install the vertical baffles that are included with the unit to improve the flame appearance. Install each baffle to cover the outside two slots in the lower firebox top. See Figure 15.7.



Figure 15.7 Adjust the Vertical Baffle

## F. Install Logs, Ember Bed & Rockwool

- Remove the grate from the hearth by removing the screws.
- Position rear log over the locating tabs at the rear of the hearth pan. See Figure 15.8.



Figure 15.8 Positioning Rear Log

- Position ember bed over the burner locating the corners inside the brackets. See Figure 15.9.



Figure 15.9 Positioning Ember Bed

- Position the grate in the recess of the ember bed and attach to the hearth with the screws. See Figure 14.10.



Figure 15.10 Positioning Grate

- Position the cut out on the left front log over the grate bar. See Figure 15.11.



Figure 15.11 Positioning Left Front Log

- Position the right front log over the grate bars, aligning the cut outs on the bottom of the log with the bars. See Figure 15.12



Figure 15.12 Positioning Right Front Log

- Position the cutout on the bottom of the left log over the locating bracket on the grate. Push the top of the rear log back against the back refractory and position the left log on the flat area of the rear log. See Figure 15.13.



Figure 15.13 Positioning Left Log

- Position the right log over the locating bracket on the grate and position the end on the flat area of the rear log. See Figure 15.14.



Figure 15.14 Positioning Right Log

- Place the end of the right middle log on the flat area on the ember bed and position the hole in the log over the exposed locator pin on the front log. See Figure 15.15.



Figure 15.15 Positioning Right Middle Log

- Place the end of the left middle log on the flat area of the ember bed and position the hole in the log over the exposed locator pin on the front log. See Figure 15.16.



Figure 15.16 Positioning Left Middle Log



**WARNING! Risk of Explosion!** Follow rockwool placement instructions. **DO NOT** place rockwool directly over burner ports. Replace rockwool material annually. Improperly placed rockwool interferes with proper burner operation.

- Rockwool is shipped with this gas appliance.
- Place individual pieces of wool loosely in the ember bed slots. Do not block the burner ports by packing tightly.



Figure 15.17 Placing Rockwool

### G. Install Andirons

Install andirons with the screws provided. See Figure 15.18.



Figure 15.18 Installing Andirons

### H. Place Lava Rock and Vermiculite

- Cover the visible area of the metal hearth pan around the ember bed with a layer of lava rock.
- Lightly sprinkle vermiculite over the lava rock.



Figure 15.19 Placing Lava Rock

### I. Reinstall Glass

- Reinstall glass by reversing steps in Section 15.A.

### J. Install Door Fronts

The doors should be lifted off the frame at the hinges to make installation easier.

- Make sure the templates have been removed, retain the screws.
- Fit the frame inside the unit opening and use the screws from the facing template to attach the door frame to the unit.
- Install the doors by hanging on the hinges.
- Install the door handles if necessary.

# 16 Troubleshooting

With proper installation, operation, and maintenance your gas appliance will provide years of trouble-free service. If you do experience a problem, this troubleshooting guide will assist a qualified service technician in the diagnosis of a problem and the corrective action to be taken. This troubleshooting guide can only be used by a qualified service technician. Contact your dealer to arrange a service call by a qualified service technician.

## A. Standing Pilot Ignition System

Symptom		Possible Causes	Corrective Actions
1	After repeated triggering of the electronic spark igniter the pilot will not light.	a. Defective igniter.	Check the spark at the electrode and pilot. If no spark and electrode wire is properly connected, replace the igniter AA battery.
		b. Defective pilot or misaligned electrode (spark at electrode).	Use a match to light the pilot. If the pilot lights, turn off the pilot and trigger the button again. If the pilot lights, an improper gas/air mixture caused the bad lighting and a longer purge period is recommended. If the pilot will not light, ensure the gap at the electrode and pilot is 1/8 in. to have a strong spark. If the gap is OK, replace the pilot.
		c. No gas or low gas pressure.	Check the remote shut-off valves from the fireplace. Usually, there is a valve near the gas main. There can be more than one valve between the fireplace and the main.
		d. No LP in the tank.	Check the LP (propane) tank. You may be out of fuel.
2.	The pilot will not stay lit after carefully following the lighting instructions.	a. Defective thermocouple.	Check that the pilot flame impinges on the thermocouple. Clean and/or adjust the pilot for maximum flame impingement. Ensure that the thermocouple connection at the gas valve is fully inserted and tight (hand tighten plus 1/4 turn). Disconnect the thermocouple from the valve, place one millivolt meter lead wire on the tip of the thermocouple and the other meter lead wire on the thermocouple copper lead. Start the pilot and hold the valve knob in. If the millivolt reading is less than 15mV, replace the thermocouple.
		b. Defective valve.	If the thermocouple is producing more than 15 millivolt, replace faulty valve.
3.	The pilot is burning, there is no burner flame, the valve knob is in the ON position, and the MLT OFF/REMOTE/ON switch is in the REMOTE position.	a. Power failure.	Verify that 120 VAC is present at the unit. If power is OFF, the MLT switch must be placed in the ON position unless an optional wall thermostat or switch is installed. The optional thermostat or switch will control the burner operation. The burner defaults to high when power is OFF.
		b. Remote receiver or wires defective.	Check the RED wires for proper connections. Place a jumper wire across the TH-TP and TH terminals at the gas valve. If the burner comes on, remove the jumper and place the MLT switch in the ON position. If the burner comes ON, refer to the troubleshooting documents for the MLT remote control.
		c. Thermopile may not be generating sufficient millivolt signal.	If the pilot flame is not physically close enough to the thermopile, adjust the pilot flame. Be sure the wire connections from the thermopile at the gas valve terminals are tight and that the thermopile is fully inserted into the pilot bracket. Check the thermopile with a millivolt meter. With the pilot lit, disconnect the thermopile leads from the valve. Take a reading at the thermopile leads. The reading should be 325 millivolt minimum. Replace the thermopile if the reading is below the minimum. Reconnect the thermopile leads. Be sure the wire connections from the thermopile at the gas valve terminals are tight.
		d. Defective valve.	Turn on the valve knob to the ON position. Place the MLT switch in the ON position. Check the millivolt meter reading at the thermopile terminals. The millivolt meter should read greater than 125mV. If the reading is acceptable, and if the burner does not come on, replace the gas valve.
		e. Plugged burner orifice.	Check the burner orifice for stoppage. Remove stoppage.
		f. Optional wall thermostat wires are defective.	Disconnect the red MLT wires. Jumper the leads at the wall thermostat or wall switch. Check the thermostat, switch and wiring. Replace where defective.

## Troubleshooting (continued)

Symptom		Possible Causes	Corrective Actions
4.	Rear burner switch does not turn OFF the back burner.	a. Power failure.	Verify that 120 VAC is present at the unit. If power is OFF, the MLT switch must be placed in the ON position unless an optional wall thermostat or switch is installed. The optional thermostat or switch will control the burner operation. The burner defaults to high when power is OFF.
		b. Rear burner switch is defective.	Ensure that the interface is securely attached to the switch. Jumper the terminals of the switch. If the back burner goes OFF, replace the switch.
		c. 9vdc power supply defective.	Disconnect the power supply from the interface. Use a dc volt meter on the plug the tip is positive. If the voltage is less than 9vdc, replace the power supply.
		d. Defective interface module.	Disconnect the front solenoid red and black wires. Momentarily touch to a 9 volt battery. Reverse the battery and momentarily touch to the battery again. If you hear the solenoid snap when it toggles, replace the interface module. Reverse the battery again. If the solenoid does not snap, replace the solenoid block.
5.	Frequent pilot outage problem.	a. Pilot flame may be too high or low, or blowing (high), causing pilot safety to drop out.	Clean and adjust the pilot flame for maximum flame impingement on thermocouple. Follow lighting instructions carefully.
6.	The pilot and main burner extinguish while in operation.	a. No LP in tank.	Check the LP (propane) tank. Refill the fuel tank.
		b. Inner vent pipe leaking exhaust gases back into the system.	Check for gas leaks.
		c. Horizontal vent improperly pitched.	The horizontal vent cap should slope down only enough to prevent any water from entering the unit. The maximum downwards slope is 1/4 in.
		d. Glass too loose and air tight packet leaks in corners after usage.	Tighten the corner.
		e. Bad thermopile or thermocouple.	Replace if necessary.
		f. Improper vent cap installation.	Check for proper installation and freedom from debris or blockage.
7.	Glass soots.	a. Flame impingement.	Adjust the log set so that the flame does not excessively impinge on it.
		b. Improper venturi setting.	Adjust the air shutter at the base of the burner.
		c. Debris around venturi.	Inspect the opening at the base of the burner. <b>NO MATERIAL SHOULD BE PLACED IN THIS OPENING.</b>
8.	Flame burns blue and lifts off burner.	a. Insufficient oxygen being supplied.	Ensure that the vent cap is installed properly and free of debris, and that the vent system joints are tight and have no leaks. Ensure that no debris has been placed at the base of, or in the area of the air holes in the center of the base pan beneath the burner. Ensure that the glass is tightened properly on the unit, particularly on top corners.

# 17 Reference Materials

## A. Appliance Dimension Diagram

Dimensions are actual appliance dimensions. Use for reference only. For framing dimensions and clearances refer to Section 5.

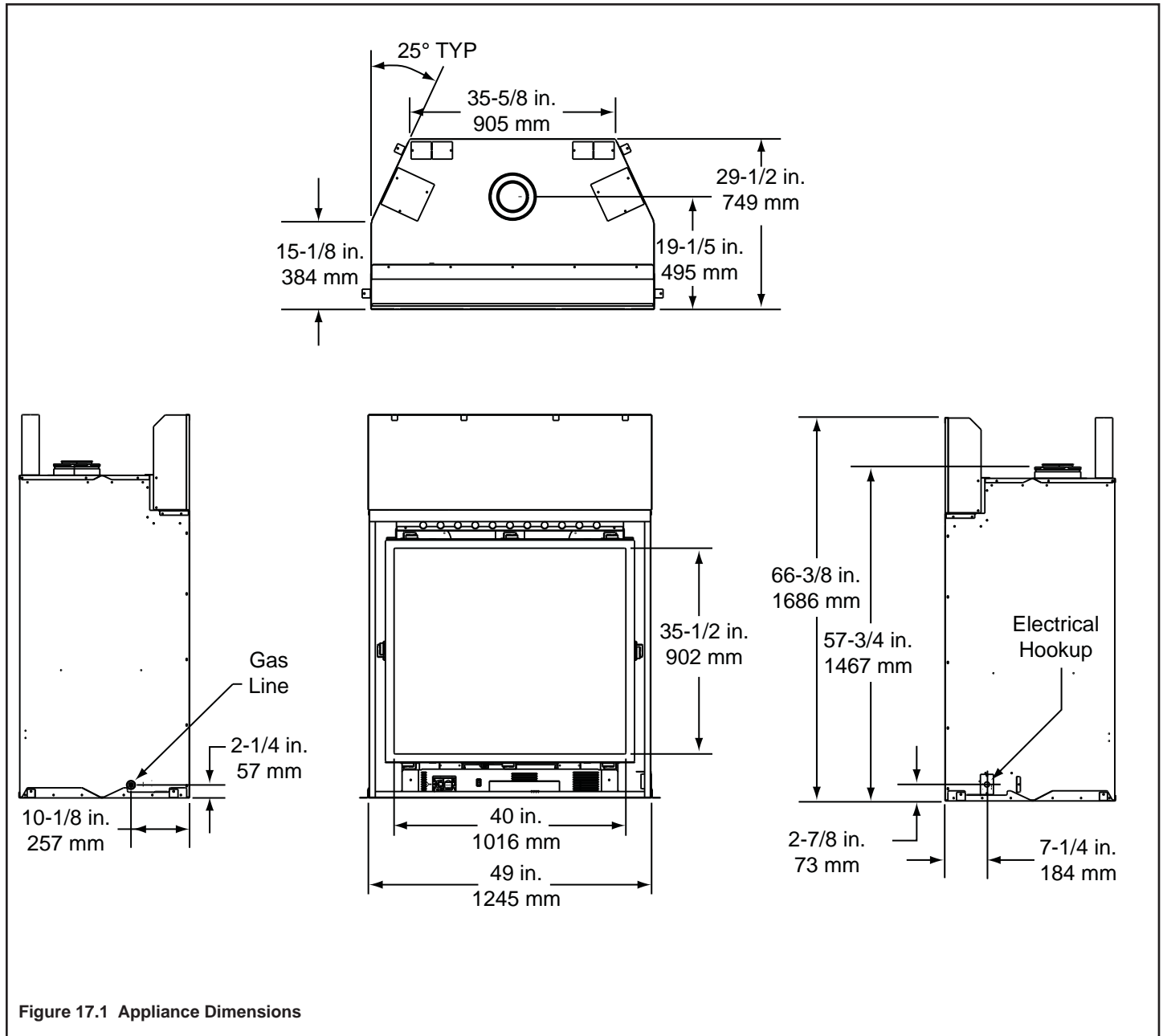
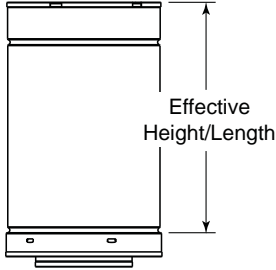

Figure 17.1 Appliance Dimensions

## B. Vent Components Diagrams



**DVP Pipe**  
(see chart)

Effective Height/Length		
Pipe	inches	mm
DVP4	4	102
DVP6	6	152
DVP12	12	305
DVP24	24	610
DVP36	36	914
DVP48	48	1219
DVP6A	3 - 6	76 - 152
DVP12A	3 - 12	76 - 305

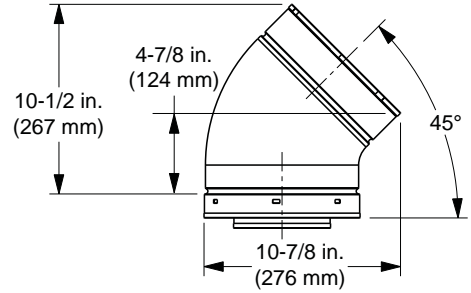

**DVP45**  
**45° Elbow**

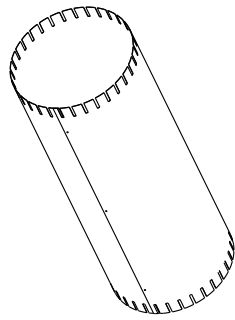

**Assembled**  
**Height: 24 in./610 mm**  
**Diameter: 10 in./254 mm**

**DVP-AS2**

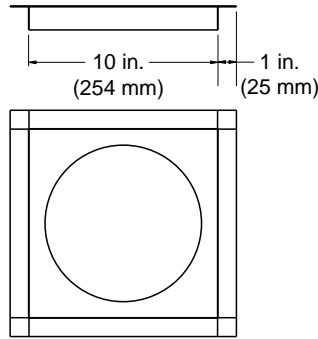

**DVP-FS**  
**Ceiling Firestop**

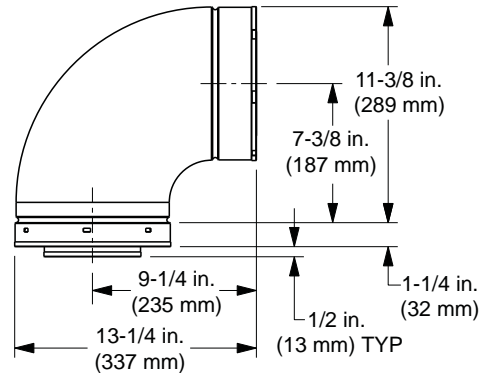

**DVP90ST**  
**90° Elbow**

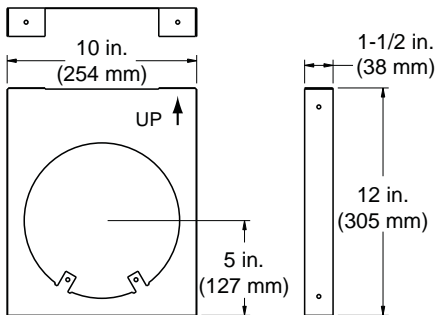

**DVP-HVS**  
**Vent Support**

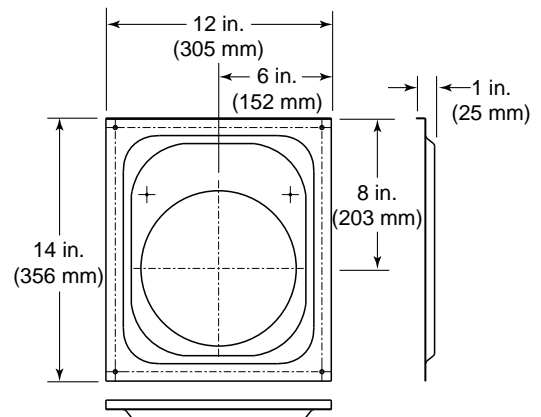

**DVP-WS**  
**Wall Shield Firestop**

Figure 17.2 DVP Vent Components

## B. Vent Components Diagrams (continued)

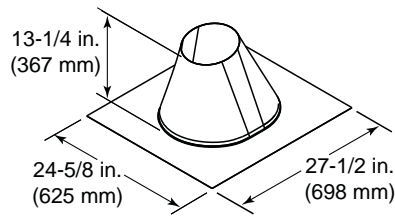

**RF6M**  
Roof Flashing Multi-pak

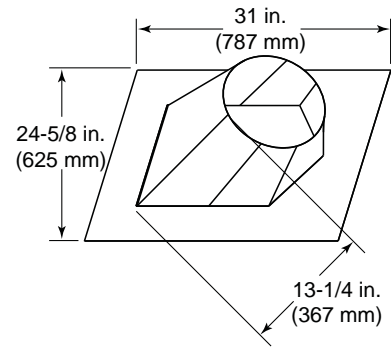

**RF12M**  
Roof Flashing Multi-pak

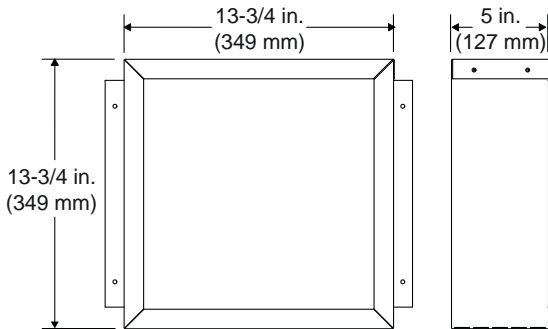

**BEK**  
Trap Cap Brick Extension

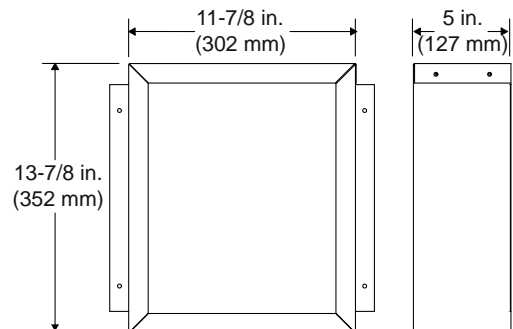

**DVP-BEK2**  
DVP-HPC Cap Brick Extension

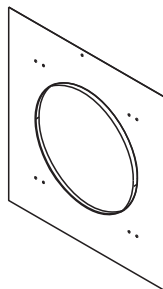

**DVP-TRAPFL**  
Flashing

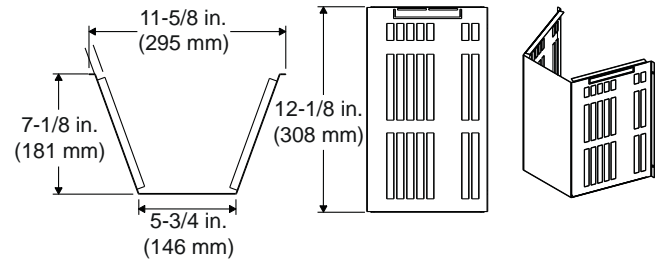

**COOL-ADD**  
Cap Shield

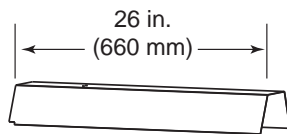

**DVP-HSM-B**  
Extended Heat Shield

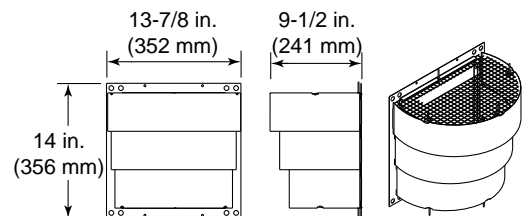

**DRC-RADIUS**  
Cap Shield

Figure 17.3 DVP Vent Components

## B. Vent Components Diagrams (continued)

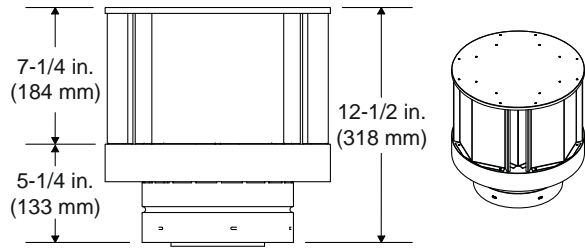

**DVP-TVHW**  
Vertical Termination Cap (High wind)

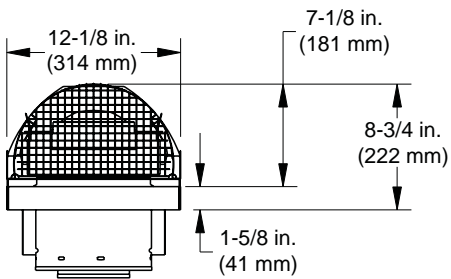
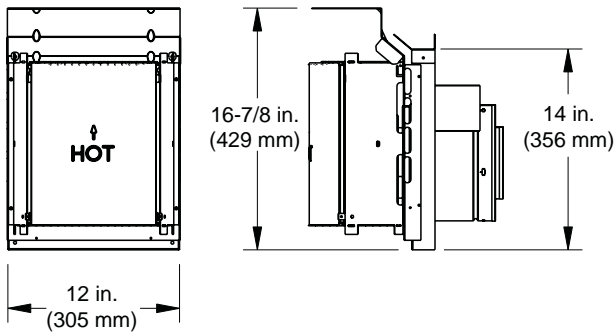

**DVP-HPC**  
High Performance Cap

Figure 17.4 DVP Vent Components

## B. Vent Components Diagrams (continued)

Note: Heat shields MUST overlap by a minimum of 1-1/2 in. (38 mm). **The heat shield is designed to be used on a wall 4 in. to 7-1/4 in. (102 mm to 184 mm) thick.** If wall thickness is less than 4 in. (102 mm) the existing heat shields must be field trimmed. If wall thickness is greater than 7-1/4 in. (184 mm) a DVP-HSM-B will be required.

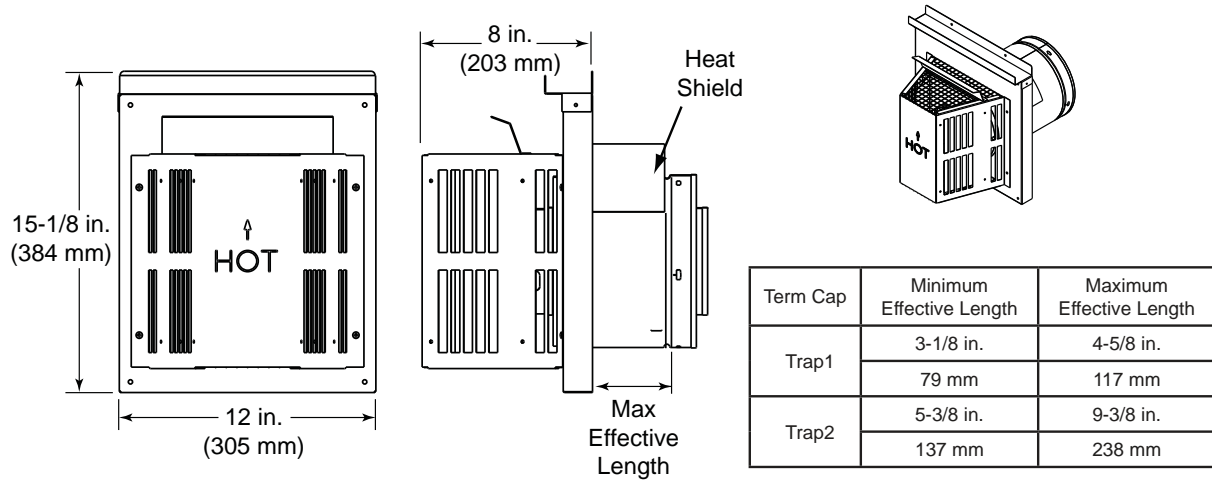

### DVP-TRAP Horizontal Termination Cap

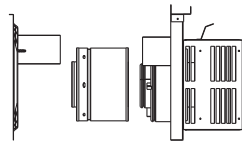

DVP-TRAP1

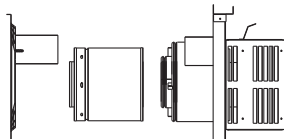

DVP-TRAP2

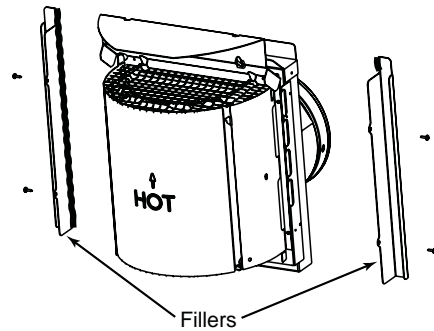

DVP-TRAP to DVP-HPC Side Filler Kit

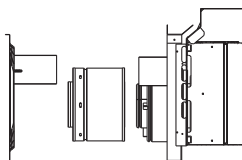

DVP-HPC1

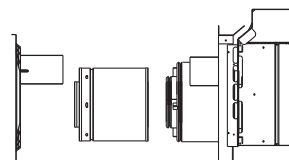

DVP-HPC2

Figure 17.5 DVP Vent Components



## D. Optional Components

Door (iron full view)	DF-QFP44-IFV
Door (iron operable)	DF-QFP44-IOP
Door (Craftsman operable, black)	DF-QFP44-COP-BK
Door (Craftsman operable, sienna bronz)	DF-QFP44-COP-SB
Wall Thermostat - Manual	812-3760
Wall Thermostat - Programmable	811-0520
Heat Zone Kit	QFP-HEAT-ZONE
Conversion Kit, LP	44CKP
Conversion Kit, NG	44CKN

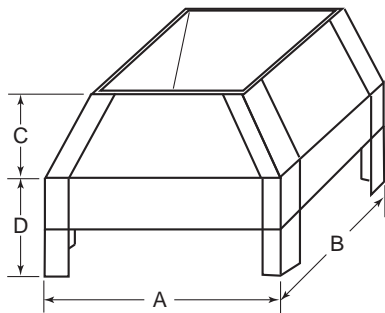

LDS33/LDS46 Decorative Shroud

Catalog #	A		B		C		D	
	in.	mm	in.	mm	in.	mm	in.	mm
LDS33	36	914	36	914	8.5	216	11	279
LDS46	48	1219	72	1829	8.5	216	11	279

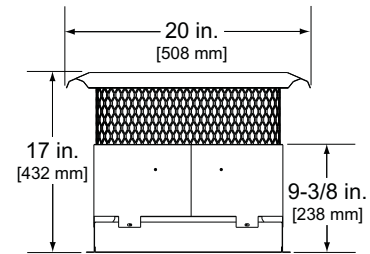

TCG375 Terra Cotta Cap

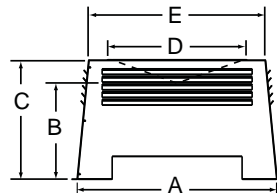
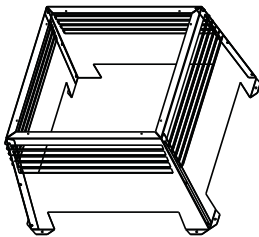

LDS-BV Decorative Shroud

Catalog #	A	B	C	E	E	
	LDS-BV	in.	26	12.5	15.5	22
mm		660	318	394	533	584

LDSCP-M Shroud Leg Multipack  
(not shown)

**See your QuadraFire dealer for a complete listing of optional components.**

E. Contact Information



Quadra-Fire, a brand of Hearth & Home Technologies Inc.  
7571 215<sup>th</sup> Street West, Lakeville, MN 55044  
www.quadrafire.com

Please contact your Quadra-Fire dealer with any questions or concerns.  
For the location of your nearest Quadra-Fire dealer,  
please visit www.Quadra-Fire.com.

**- NOTES -**

---

---

---

---

---

---

---



---

---

---

**NOTICE**

---

	<b>DO NOT DISCARD THIS MANUAL</b>	
<ul style="list-style-type: none"><li>• Important operating and maintenance instructions included.</li></ul>	<ul style="list-style-type: none"><li>• Read, understand and follow these instructions for safe installation and operation.</li></ul>	<ul style="list-style-type: none"><li>• Leave this manual with party responsible for use and operation.</li></ul>

This product may be covered by one or more of the following patents: (United States) 5328356, 5601073, 5613487, 5647340, 5890485, 5941237, 5947112, 5996575, 6006743, 6019099, 6053165, 6145502, 6170481, 6374822, 6484712, 6601579, 6769426, 6863064, 7077122, 7098269, 7258116, 7470729 or other U.S. and foreign patents pending.

2000-945

Printed in U.S.A. - Copyright 2011