

259-S-02-2

SAFETY NOTICE

If this heater is not properly installed, operated, and maintained, a house fire may result. For safety, follow all installation, operation and maintenance directions. Contact local building officials about restrictions and installation inspection requirements in your area.

NATIONAL FIREPLACE INSTITUTE

CERTIFIED
www.nficertified.org

We recommend that our woodburning hearth products be installed and serviced by professionals who are certified in the U.S. by the National Fireplace Institute® (NFI) as NFI Woodburning Specialists or who are certified in Canada by Wood Energy Technical Training (WETT).

 **Wood Energy Technical Training**
www.wettinc.com

This unit has been retired.
Service parts pages within have been removed.
For replacement parts, please refer to the individual service parts list located on the brand website.

The French language version of this manual is available online: www.vermontcastings.com
La version française de ce manuel est disponible en ligne : www.vermontcastings.com

DO NOT DISCARD THIS MANUAL: Retain for future use

The Dutchwest Model 2478 covered in this Owner's Guide has been tested and listed by OMNI - Test Laboratories, Inc. of Portland, Oregon. The test standards utilized were UL 1482-1996 for the United States and ULC-S627-00 for Canada. Dutchwest Model 2478 is not listed for mobile home installations.

Table of Contents

| | |
|-------------------------------|----|
| Specifications | 3 |
| Installation | 4 |
| Clearances | 10 |
| Assembly | 16 |
| Smoke Alarm/Safety Tips | 18 |
| Operation..... | 19 |
| Maintenance | 24 |
| Warranty | 30 |

Patents:

U.S.: D288357, 4502395, 4646712

Resolute Acclaim: 4683868, D308246

Canada: 1235969. Other foreign mechanical patents issued.

This heater meets the U.S. Environmental Protection Agency's emission limits for wood heaters sold on or after May 15, 2015.

PLEASE NOTE

Read this entire manual before you install and use your new room heater. Failure to follow instructions may result in property damage, bodily injury or loss of life. Save these instructions for future use.

Accessories

- Clearance-reducing Right Side Heat Shields
- Clearance-reducing Heat Shields for single-wall stove pipe
- Variable-speed Blower
- Outside Air Termination Kit
- Clearance Reducing Rear Exit Flue Heat Shield
- Clearance Reducing Top Exit Flue Heat Shield

Proposition 65 Warning: Fuels used in gas, woodburning or oil fired appliances, and the products of combustion of such fuels, contain chemicals known to the State of California to cause cancer, birth defects and other reproductive harm.
California Health & Safety Code Sec. 25249.6

Specifications

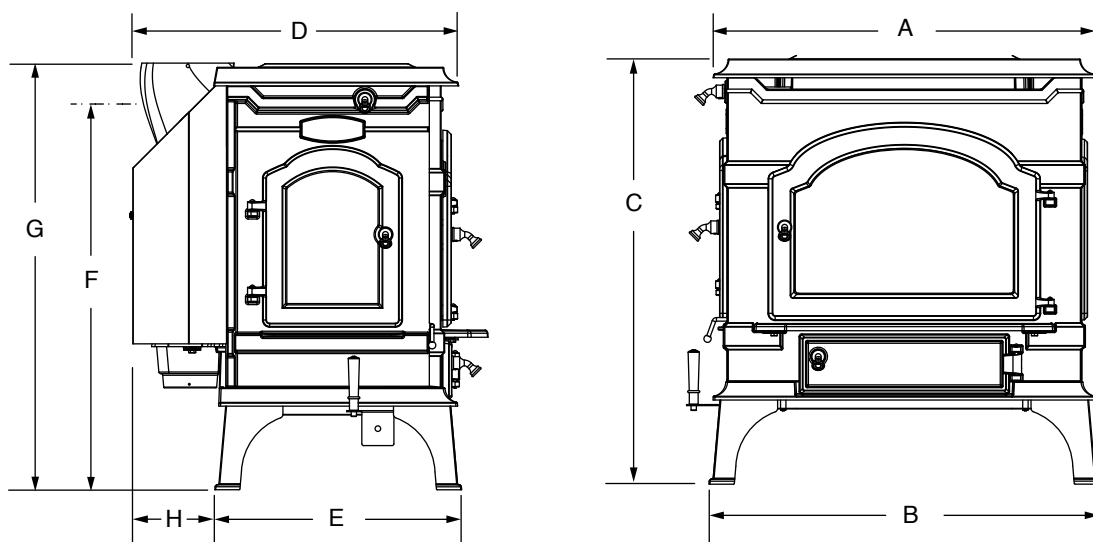

Model 2478

| | |
|--|--|
| A | 26¾" (683 mm) |
| B | 27¼" (695 mm) |
| C | 29¾" (756 mm) |
| D | 23" (584 mm) |
| E | 17½" (445 mm) |
| F | 27¼" (692 mm) Center of Flue Collar, Rear Exit |
| G | 30½" (775 mm) |
| H | 5¾" (146 mm) |
| Log length | 22" (560 mm) |
| Maximum burn time ¹ | Up to 10 hrs. |
| Average area heated (sq. ft.) ² | 800 - 1600 (74 - 149 m ²) |
| Range of heat output ⁴ | 10,600 - 25,300 Btu/hr. |
| Maximum heat output ¹ | 40,000 Btu/hr. |
| EPA emissions rating ⁴ (g/h, non-catalytic) | 1.49 |
| Efficiency, HHV ⁵ | 77% |
| Weight | 420 lbs. (191 kg) |
| Loading | Side or front |
| Flue exit position (reversible) | Top or rear |
| Air control | One |

Figure 1 - Dutchwest Convection Heater specifications.

- Maximum burn times and heat outputs are based on laboratory testing using full loads of seasoned hardwoods, and may vary in individual use depending on how the stove is operated, type and moisture content of fuels, and other factors. Maximum burn times are achieved under different operating conditions than are maximum heat outputs.
- These values are based on operation in building code-conforming homes under typical Winter climate conditions in the northeastern U.S. If your home is of nonstandard construction (e.g. unusually well-insulated, not insulated, built underground, or if you live in a more severe or more temperate climate), these figures may not apply. Since so many variables affect performance, consult your Dutchwest Authorized Dealer to determine realistic expectations for your home.
- Under specific conditions used during EPA emissions testing.
- Efficiency determined by CSA B415.10.

Installation

SAFETY NOTICE: IF YOUR DUTCHWEST CONVECTION HEATER IS NOT PROPERLY INSTALLED, OPERATED AND MAINTAINED, A HOUSE FIRE MAY RESULT. FOR SAFETY, FOLLOW ALL INSTALLATION, OPERATION AND MAINTENANCE DIRECTIONS. CONTACT LOCAL BUILDING OFFICIALS ABOUT RESTRICTIONS AND INSTALLATION INSPECTION REQUIREMENTS IN YOUR AREA.

Before you begin the installation, review your plans to confirm that:

- Your stove and chimney connector will be far enough from combustible material to meet all clearance requirements.
- The floor protector is large enough and is constructed properly to meet all requirements.
- You have obtained all necessary permits from local authorities.

Your local building official is the final authority for approving your installation as safe and for determining that it meets local and state codes.

Clearance and installation information is printed on the metal label attached to the rear of the stove. Local authorities generally will accept the label as evidence that, when the stove is installed according to the information on the label and in this manual, the installation meets codes and can be approved.

Codes vary in different areas, however. Before starting the installation, review your plans with the local building authority. Your local dealer can provide any additional information needed.

Important: Failure to follow these installation instructions may result in a dangerous situation, including a chimney or house fire. Follow all instructions exactly, and do not allow makeshift compromises to endanger property and personal safety.

Chimney Types

Your Dutchwest Convection Heater must be connected to 1) a chimney complying with the requirements for Type HT chimneys in the standard for Chimneys, Factory-Built, Residential Type and Building Heating Appliance, UL 103, or 2) a code-approved masonry chimney with a flue liner.

Whatever kind you use, the chimney and chimney connector must be in good condition and kept clean.

Masonry Chimneys

If you use an existing masonry chimney, it must be inspected to ensure safe condition before the stove is installed. Your local professional chimney sweep, building inspector, or fire department official will be able either to make the inspection or to direct you to someone who can.

An inspection of the chimney must confirm that it has a lining. Do not use an unlined chimney. The chimney should also be examined for cracks, loose mortar, other signs of deterioration, and blockage. Repair any defects before the chimney is used with your stove.

Unused openings in an existing masonry chimney must be sealed with masonry to the thickness of the chimney wall, and the chimney liner should be repaired. Openings sealed with pie plates or wallpaper are a hazard and should be sealed with mortar or refractory cement. In the event of a chimney fire, flames and smoke may be forced out of these unused thimbles.

The chimney should be thoroughly cleaned before use.

A newly-built masonry chimney must conform to the standards of your local building code or, in the absence of a local code, to a recognized national code. Masonry chimneys must be lined, either with code-approved masonry or pre-cast refractory tiles, stainless steel pipe, or a code-approved, "poured-in-place" liner. The chimney's clean-out door must seal tightly.

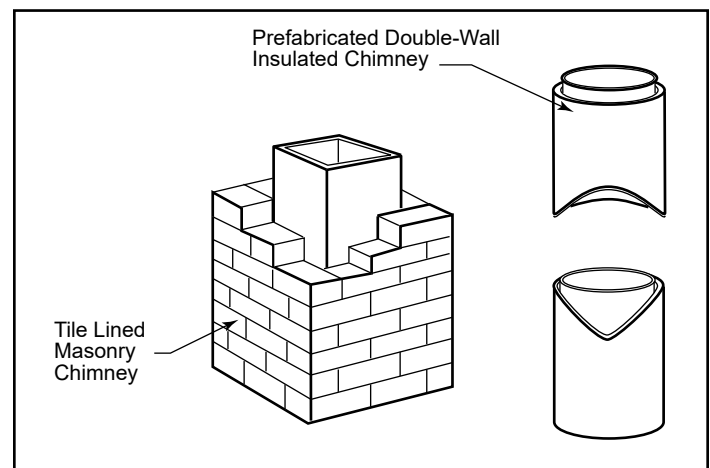

Figure 2 - If in sound condition and approved for use, either a masonry or a prefabricated chimney may be used.

Prefabricated Chimneys

A prefabricated metal chimney must be one tested and listed for use with solid-fuel burning appliances.

A horizontal connector run should be inclined 1/4" per foot (20 mm per meter) from the stove toward the chimney. The recommended maximum length of a horizontal run is 3 feet (1 m) and the total length of chimney connector should be no longer than 8 feet (2.5m).

Chimney Height

For proper draft and good performance, the chimney should extend at least 16' (5 m) above the flue collar of the stove.

The chimney must also extend at least 3' (914 mm) above the highest point where it passes through a roof, and at least 2' (610 mm) higher than any portion of a building within 10' (3 m). (Figure 2)

DO NOT CONNECT THIS UNIT TO A CHIMNEY FLUE SERVING ANOTHER APPLIANCE.

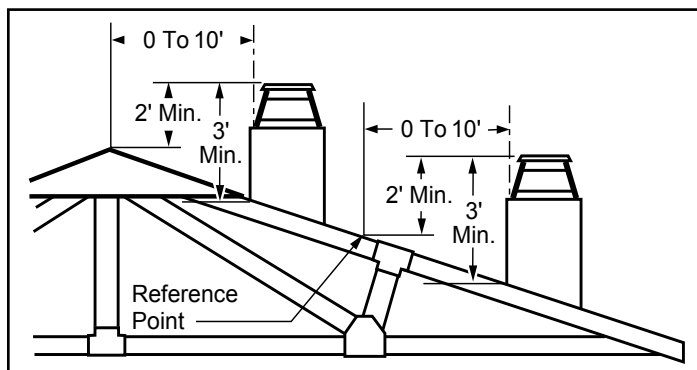

Figure 3 - The 2/3/10 rule for chimneys.

Chimney Size

The Model 2478 heater should be vented into a masonry chimney with a square flue with nominal flue size of 8" x 8" (203 x 203 mm), or a round flue with nominal flue size of 6" (152 mm).

Chimney liners larger than 8" x 12" (203 x 305 mm) may promote rapid cooling of smoke and reduction in draft, especially if they are located outside the home. These large chimneys may need to be insulated or have their flues relined for proper stove performance.

Accessories to help make the connection between stainless steel chimney liners and the stove are available through your local dealer.

Guidelines for Installing the Chimney Connector

The chimney connector is the single-wall pipe, or listed and approved double-wall pipe that connects the stove to the chimney. The chimney itself is a masonry or prefabricated structure that encloses the flue. Chimney connectors are used only to make the connection from the stove to the chimney.

Do not pass the chimney connector through a combustible wall, floor, or ceiling, through an attic or roof space, or through a closet or similar concealed space. If passage through a combustible wall is unavoidable, follow the recommendations in the following section on Wall Pass-Throughs. Keep the passage as short and direct as possible, with no more than two 90 degree turns.

Two Types of Connector

You may use either a single-wall steel connector of the size and gauge described below, or a listed and approved double-wall connector.

Single-Wall Connector

The single-wall chimney connector should be made of 24 gauge or heavier steel, and must have a minimum internal diameter of 6" (150 mm) for model 2478.

Install single-wall chimney connector not less than 18" (450 mm) from the ceiling.

In cathedral ceiling installations, extend the prefabricated chimney downward to within 8 feet (2.5 meters) of the stove. The entire chimney connector should be exposed and accessible for inspection and cleaning.

Do not use galvanized chimney connector; it cannot withstand the high temperatures that can be reached by smoke and exhaust gases and it may release toxic fumes under high heat.

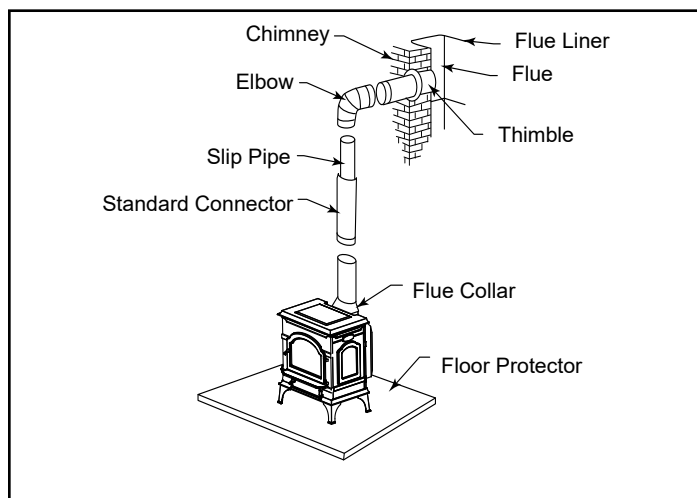

Figure 4 - Sections of a steel chimney connector of at least 24 gauge thickness are fastened together with screws to connect the stove to the chimney.

Double-Wall Connector

Information on assembling and installing double-wall connectors is provided by the manufacturer of the double-wall pipe. Follow the manufacturer's installation instructions exactly. Most manufacturers of prefabricated double-wall insulated chimneys also offer double-wall connector pipes. Using a chimney and connector pipe from the same manufacturer helps simplify the assembly and installation.

NOTE: For installations using double-wall connectors, minimum clearances must conform to listed clearances in the Stove and Chimney Connector Clearance Charts on Page 12 and 13 of this manual.

Assembling Single-Wall Chimney Connector

SAFETY NOTE: Always wear gloves and safety goggles when drilling, cutting or joining sections of chimney connector.

For double-wall connectors, follow the manufacturer's instructions exactly. For single-wall connectors, follow the instructions below.

1. Insert the crimped end of the first section into the stove's flue collar, and keep each crimped end pointing toward the stove (Figure 5). Using the holes in the flue collar as guides, drill 1/8" (3 mm) holes in the bottom of the first section of chimney connector and secure it to the flue collar with three #10 x 1/2" sheet metal screws.
2. Secure each joint between sections of chimney connector, including telescoping joints, with at least three sheet metal screws.
3. Secure the chimney connector to the chimney. Instructions for various installations follow below.
4. Confirm that the installed stove and chimney connector are correct distances from nearby combustible material. See the clearance charts on pages 12 and 13.

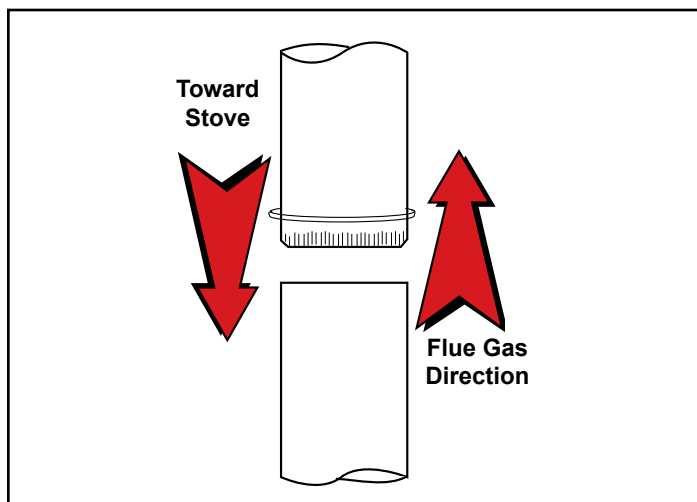

Figure 5 - Crimped sections always point toward the stove so that any liquid condensation will not leak out.

NOTE: Special slip pipes and thimble sleeves that form telescoping joints between sections of chimney connector are available to simplify installations. They can eliminate the need to cut individual connector sections. Consult your local dealer about these special pieces.

Securing the Connector to a Prefabricated Chimney

Follow the installation instructions of the chimney manufacturer exactly as you install the chimney. The manufacturer of the chimney will supply the accessories to support the chimney, either from the roof of the house, at the ceiling of the room where the stove is installed, or from an exterior wall.

Special adapters are available from your local dealer to make the connection between the prefabricated chimney and the chimney connector. (Figure 6) The top of such adapters attach directly to the chimney or to the chimney's ceiling support package, while the bottom of the adapter is screwed to the chimney connector.

These adapters are designed so the top end will fit outside the inner wall of the chimney, and the bottom end will fit inside the first section of chimney connector. Any soot or creosote falling from the inner walls of the chimney will stay inside the chimney connector.

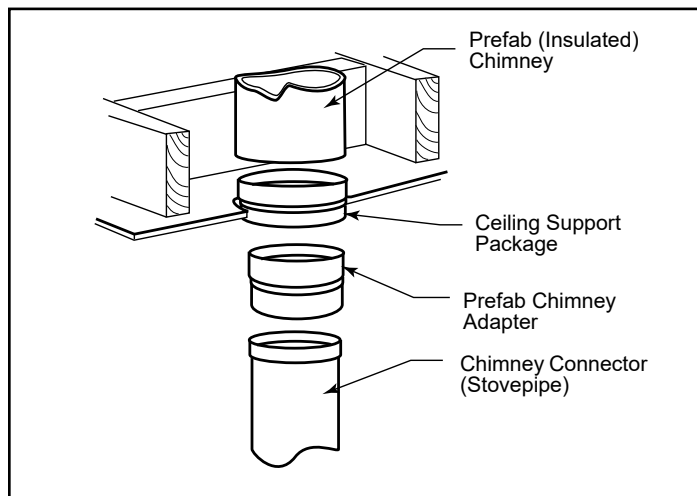

Figure 6 - Joining the chimney connector to a prefabricated chimney.

Securing the Connector to a Masonry Chimney

The Dutchwest Convection heater may be connected to either a freestanding masonry chimney or a masonry fireplace chimney.

Freestanding Installations

If the chimney connector must pass through a combustible wall to reach the chimney, follow the recommendations in the wall pass-through section that follows.

The opening through the chimney wall to the flue (the "breach") must be lined with either a ceramic or metal cylinder, called the "thimble", which is securely cemented in place. (Figure 7) Most chimney breeches incorporate thimbles, but check to be sure the fit is snug and the joint between thimble and chimney wall firmly cemented.

A special piece called the "thimble sleeve," slightly smaller in diameter than the standard connector and most thimbles, will ease the removal of the chimney connector system for inspection and cleaning. Thimble sleeves should be available from your local dealer.

To install a thimble sleeve, slide it into the breach until it is flush with the inner flue wall. Don't extend it into the actual flue passage, as that could interfere with the draft.

The thimble sleeve should protrude 1-2" (25-50 mm) into the room. Use furnace cement and thin gasketing to seal the sleeve in place in the thimble. Secure the chimney connector to the outer end of the sleeve with sheet metal screws.

Fireplace Installations - Above the Fireplace

In this installation, the chimney connector rises from the stove, turns ninety degrees, and goes back into the fireplace chimney. The liner of the fireplace chimney should extend at least to the point at which the chimney connector enters the chimney. Follow all the guidelines for installing a chimney connector into a freestanding masonry chimney, and pay special attention to these additional points:

- Check the stove and chimney connector clearances to combustible mantel or trim materials. Use the necessary combination of mantel, trim, and connector heat shields to provide the required clearances. (Figure 8)
- Double-check connector clearance from the ceiling.
- The fireplace damper must be closed and sealed to prevent room air from being drawn up the flue, reducing the draft. However, it must be possible to re-open the damper to inspect or clean the chimney.

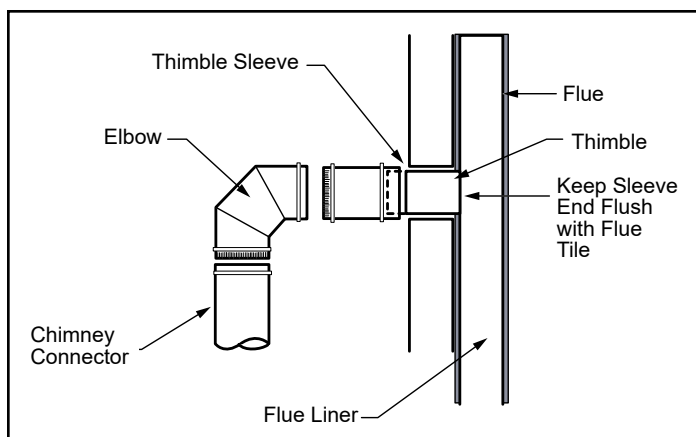

Figure 7 - The thimble, made of either ceramic or metal, must be cemented in place securely.

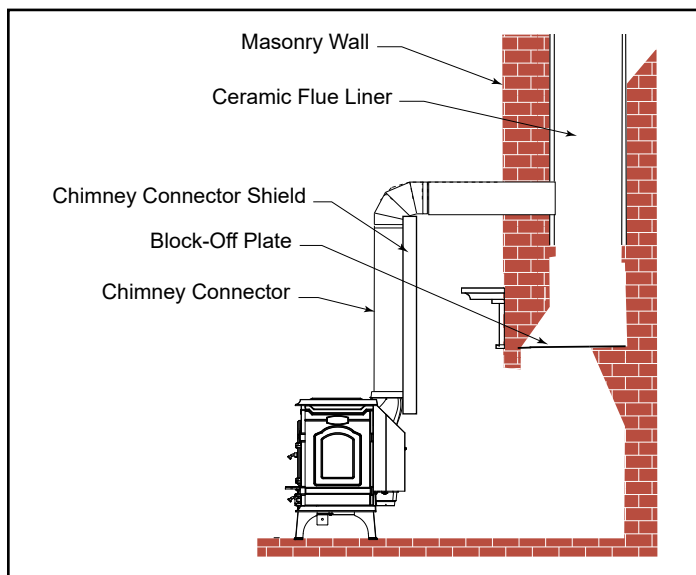

Figure 8 - The connector enters flue above the fireplace. If the clearance between the chimney connector and either the mantel and/or the ceiling is inadequate, special protective shields will be required.

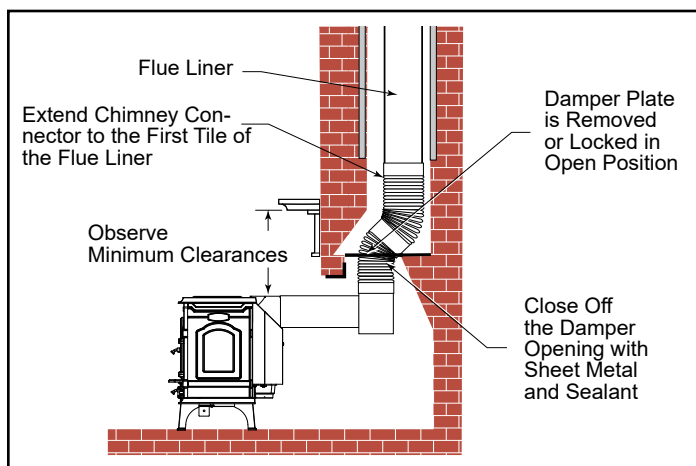

Figure 9 - The connector passes through the fireplace to enter flue. Special Fireplace Adapter Kits to simplify fireplace installations are available from your local dealer.

Fireplace Installations - Through the Fireplace

The Convection heater may be installed either without legs* as a fireplace insert, or with standard legs attached - depending on the safety regulations that apply to your situation, the height of the fireplace opening and your own preference. For either situation, the chimney connector/positive connection kit extends back from the stove, enters the fireplace cavity, and turns upward. It then passes through the fireplace damper opening and smoke chamber and connects to the chimney flue.

In such installations, a “positive connection” must be made to the chimney flue with a special kit available from your local dealer. Also, special clearance and floor protection provisions must be observed. These provisions are discussed in the Clearance and Floor Protection sections respectively.

Wall Pass-Throughs

Whenever possible, design your installation so the connector does not pass through a combustible wall. If you must use a wall pass-through in your installation, check with your building inspector before you begin and construct it in accordance with local building codes. Also check with the chimney connector manufacturer for any specific requirements.

Accessories are available for use as wall pass-throughs. If using one of these, make sure it has been tested and listed for use as a wall pass-through.

All combustible material in the wall is cut away a sufficient distance from the single-wall connector to provide the required 12" (305 mm) clearance for the connector. Any material used to close up the opening must be noncombustible.

The following wall pass-through methods may be approved in your area:

- Use a section of listed factory-built chimney with a nine-inch clearance to combustibles.
- Place a chimney connector pipe inside a ventilated thimble, which is then separated from combustibles by 6" (152 mm) of fiberglass insulating material.
- If the stove is installed without legs, we recommend the use of noncombustible tiles or pavers as shims to allow air flow into the convection air inlets under the stove. Make sure not to block air slots in stove bottom with shims or remove fan cover.
- Place a chimney connector pipe inside a section of listed solid-insulated, factory-built chimney, with an inside diameter 2" (51 mm) larger than the chimney connector and having 1" (25 mm) or more of insulation and maintaining a minimum 2 inch air space between the outer wall of the chimney and combustibles.

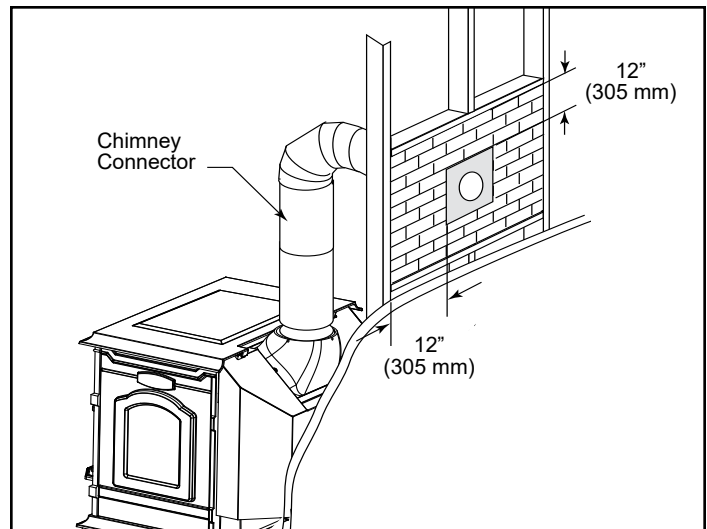

Figure 10 - Wall pass-through enclosed with noncombustible materials.

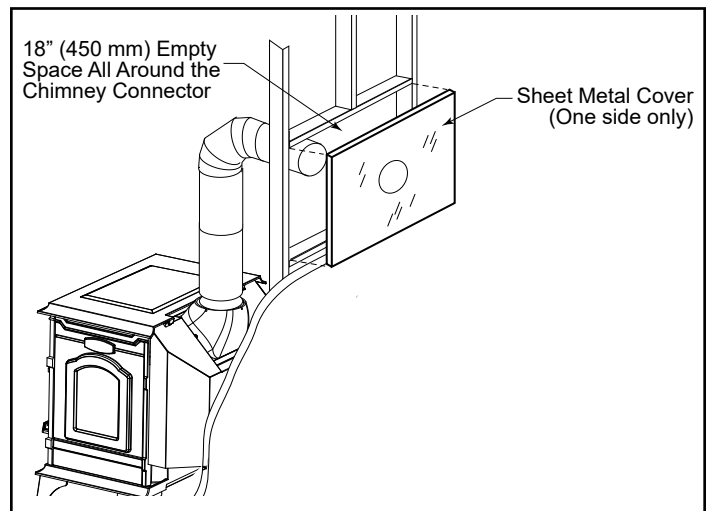

Figure 11 - Hollow wall pass-through.

DO NOT CONNECT THE HEATER TO ANY AIR DISTRIBUTION DUCT OR SYSTEM

In Canada: The Canadian Standards Association has established different guidelines. Figure 11 shows one method, in which all combustible material in the wall is cut away to provide the required 18" (450 mm) clearance for the connector. The resulting space must remain empty.

A flush-mounted sheet metal cover may be used on one side only. If covers must be used on both sides, each cover must be mounted on non-combustible spacers at least 1" (25 mm) clear of the wall. Your Dutchwest dealer or your local building inspector can provide details of other approved methods of passing a chimney connector through a combustible wall. In Canada, this type of installation must conform to CAN/CSA-B365, Installation Code for Solid Fuel Burning Appliances and Equipment.

NOTE: Do not vent your Dutchwest stove into a factory-built (zero-clearance) fireplace. These appliances and their chimneys are specifically designed as a unit for use as fireplaces. It may void the listing or be hazardous to adapt them for any other use.

Floor Protection

A tremendous amount of heat radiates from the bottom plate of your Dutchwest stove. The floor area directly under and around the stove will require protection from radiant heat as well as from stray sparks or embers that may escape the firebox.

Heat protection is provided by the Vermont Castings Group Bottom Heat Shield. Spark, ember and thermal protection must be provided by a floor protector constructed with noncombustible material as specified.

In the US and Canada most installations will require that the bottom heat shield must be attached. Only when the stove is placed on a completely noncombustible surface such as unpainted concrete over earth may it be used without the heat shield.

Even when the bottom heat shield is installed, you must provide special protection to the floor beneath. For installation with the heat shield attached, use an approved 5/8" (16mm) noncombustible hearth pad with K = 0.84 BTU/in ft² hr °F or an equivalent material with an R-value of at least 0.744. (Refer to "How to Determine if Alternate Floor Protection Materials are Acceptable" section)The floor protector may be covered with a decorative noncombustible material if desired. Do not obstruct the space under the heater.

Protection requirements vary somewhat between the United States and Canada as follows:

U.S. Installations: The floor protector is required under the stove and must extend at least 16" from the front and left (loading door) side of the stove, and at least 6" from the right side and rear. (Figure 12)

In Canada: a noncombustible floor protector is required under the heater also. The floor protector must extend 18" (457mm) from the front and left (loading door) side of the stove, and at least 8" (203mm) from the right side and rear. (Figure 12)

Due to the side loading door, floor protector requirements call for more protection on the left side than on the right. If you wish a more balanced look, increase the other side of the hearth as well. Do not reduce side protection under any circumstances.

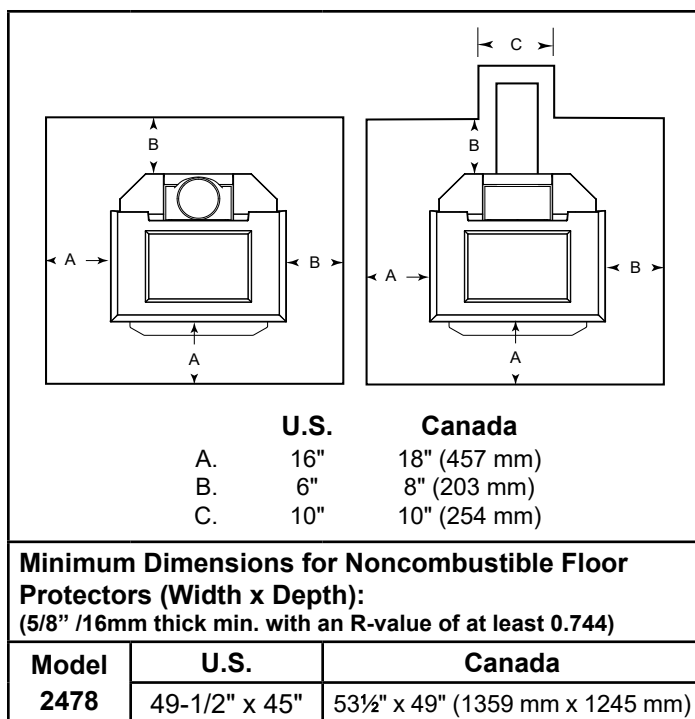

Figure 12 - Be sure to follow exactly the minimum floor protection requirements on all four sides of the stove.

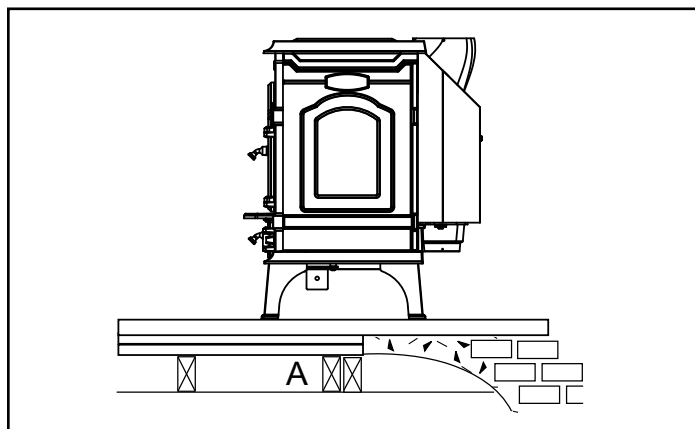

Figure 13 - Combustible supporting timbers (A) may lie beneath fireplace hearths; such situations require additional floor protection.

How to Determine if Alternate Floor Protection Materials are Acceptable

All floor protection must be noncombustible (i.e. metals, brick, stone, mineral fiber boards, etc.). Any organic materials (i.e. plastics, wood paper products, etc.) are combustible and must not be used. The floor protection specified includes some form of thermal designation such as R-value (thermal resistance) or k-factor (thermal conductivity).

Procedure:

- Convert specifications to R-value:
 - R-value given - no conversion needed.
 - k-factor is given with a required thickness (T) in inches:

$$R = \frac{1}{k} \times T$$
 - K-factor is given with a required thickness (T) in inches:

$$R = \frac{1}{K \times 12} \times T$$
 - r-factor is given with a required thickness (T) in inches:

$$R = r \times T$$
- Determine the R-value of the proposed alternate floor protector:
 - Use the formula in Step 1 to convert values not expressed as R.
 - For multiple layers, add R-values of each layer to determine overall R-value.
- If the overall R-value of the system is greater than the R-value of the specified floor protector, the alternate is acceptable.

EXAMPLE: The specified floor protector should be 1/2-inch thick material with k-factor of 0.84. The proposed alternate is 4" brick with an r-factor of 0.2 over 1/8" mineral board with a k-factor of 0.29

Step a: Use formula above to convert specification to R-value:

$$R = \frac{1}{k} \times T = \frac{1}{0.84} \times 0.5 = 0.59$$

Step b: Calculate R of proposed system.

4" brick of r = 0.2, therefore:

$$R_{\text{brick}} = 0.2 \times 4 = 0.8$$

1/8" mineral board of k = 0.29, therefore

$$R_{\text{mineralboard}} = \frac{1}{0.29} \times 0.125 = 0.431$$

$$R_{\text{total}} = R_{\text{brick}} + R_{\text{mineralboard}} = 0.8 + 0.431 = 1.231$$

Step c: Compare proposed system R_{total} of 1.231 to specified R of 0.59. Since proposed system R_{total} is greater than required, the system is acceptable.

Definitions:

$$R = \frac{(\text{ft}^2)(\text{hr})(^\circ\text{F})}{\text{Btu}} \quad k = \frac{(\text{Btu})(\text{in})}{(\text{ft}^2)(\text{hr})(^\circ\text{F})} = K \times 12$$

$$K = \frac{(\text{Btu})(\text{ft})}{(\text{ft}^2)(\text{hr})(^\circ\text{F})} \quad r = \frac{(\text{ft}^2)(\text{hr})(^\circ\text{F})}{(\text{Btu})(\text{in})} = \frac{1}{k}$$

Fireplace Installations

The Dutchwest Model 2478 has a reversible flue collar to allow for either top exit or rear exit installations.

You may install your Dutchwest Model 2478 in an existing fireplace as a fireplace insert with no legs, or with the standard legs attached.

To install the heater without legs as a fireplace insert, the floor must be completely noncombustible, such as an unpainted concrete floor over earth.

Many fireplaces do not satisfy the "completely noncombustible" requirement because the brick or concrete hearth in front of the fireplace opening usually is supported by heavy wooden framing as in Figure 13. Because heat passes readily through brick or concrete, it can easily pass through to the wood. As a result, such fireplace hearths are considered a combustible floor. You may not install a heater on a combustible hearth without legs. Standard leg installations must include the bottom heat shield. The floor protector must also meet standard requirements for freestanding installations.

Floor Protection for Fireplace Installations with Standard Legs

Fireplace installations with the standard legs and the bottom heat shield must have a floor protector of the same construction as that specified for freestanding installations: use an approved 5/8" (16mm) noncombustible hearth pad with K = 0.84 BTU/in ft² hr °F or an equivalent material with an R-value of at least 0.744 (that may be covered with a decorative noncombustible material if you desire). (Refer to "How to Determine if Alternate Floor Protection Materials are Acceptable" section) The floor protector must extend at least 16" (406 mm) [18" / 457 mm in Canada] from the front of the stove and from the left (loading door) side, and at least 8" (203 mm) from the right side and rear. It must also provide protection beneath any horizontal runs of the chimney connector, including 2" to either side.

Many raised hearths will extend less than the required distance from the front of the heater when it is installed. In such cases, sufficient floor protection, as described above, must be added to extend the hearth 16" (406 mm) [18" (457 mm) in Canada].

Hearth rugs do not satisfy the requirements for floor protection.

Fireplace insert installations also have specific clearance requirements to the side walls, side decorative trim, and fireplace mantel. This information is found in "Fireplace Installation Clearances" in this section.

REMINDER- FIREPLACE INSERT INSTALLATIONS WITHOUT LEGS ARE PERMISSIBLE ONLY IF THE HEARTH IS COMPLETELY NONCOMBUSTIBLE, SUCH AS UNPAINTED CONCRETE OVER EARTH.

Clearances

Keep the Stove a Safe Distance From Surrounding Materials

Both a stove and its chimney connector radiate heat in all directions when operating. A safe installation requires that adequate clearance be maintained between the stove and nearby combustible materials to ensure that such materials do not overheat.

Clearance is the distance between either your stove or chimney connector, and nearby walls, floors, the ceiling, and any other fixed combustible surface. Keep furnishings and other combustible materials away from the stove as well. In general, a distance of 48" (1220 mm) must be maintained between the stove and movable combustible items such as drying clothes, furniture, newspapers, firewood, etc. Keeping those clearance areas empty assures that nearby surfaces and objects will not overheat.

Safe Ways to Reduce Clearances

Your stove has specific clearance requirements that have been established through careful research and testing to UL and ULC standards.

Clearance requirements have been established to meet every installation possibility, and they involve the combination of basic variables:

- When the stove has no listed heat shield
- When the stove has a listed heat shield
- When the wall has no heat shield
- When the wall has a heat shield
- When the stove has a double-wall chimney connector
- When the stove has a single-wall connector with heat shields, or without heat shields

In general, the greatest clearance is required when you locate a stove with no heat shield near a wall with no heat shield. The least clearance is required when both the stove and the wall have heat shields. Reducing a stove clearance may require a listed heat shield on the chimney connector as well, or a double-wall connector.

Clearances may be reduced only by means approved by the regulatory authority and in accordance with the clearances listed in this manual. The charts and sample installations that follow list all the clearances required for the various installation configurations of Dutchwest Convection Heaters.

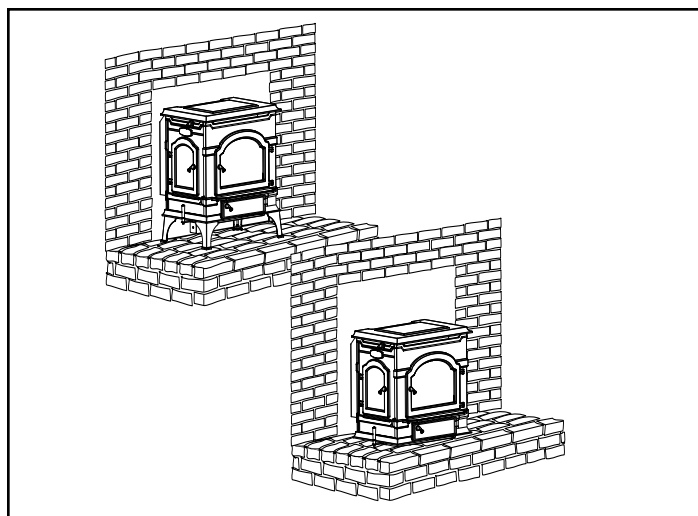

Figure 14 - Extra floor protection may be required for the fireplace hearth, even if your stove is installed with the legs and the bottom heat shield.

Fireplace Installation Clearances

A fireplace installation requires special clearance between the:

- Side of the stove and the right and left walls
- Side of the stove and the decorative side trim on the fireplace face
- Top of the stove and the mantel

In addition, both Fireplace Adapter and Fireplace Insert installations have special floor protection requirements that are addressed in the section on Floor Protection.

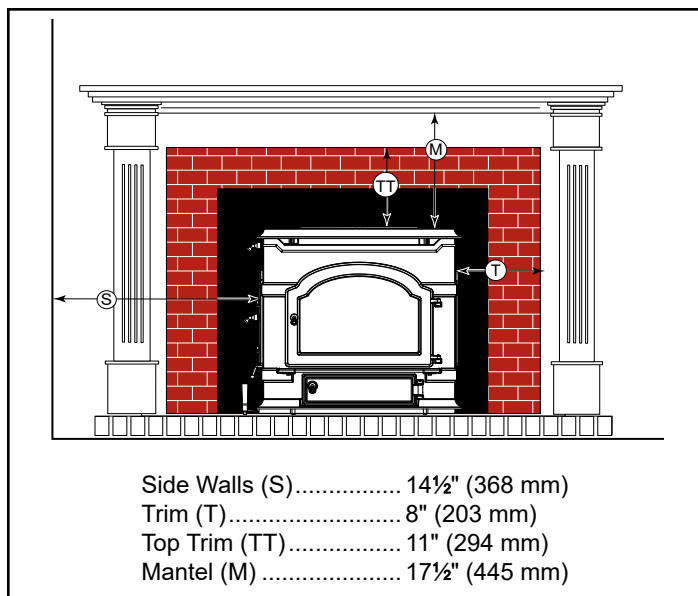

Figure 15 - Minimum clearances for fireplace installation. Recommended clearances must be maintained between stove and the surrounding combustible components.

Designing a Safe Installation

The section that follows contains charts with the information that you'll need to make your installation safe. Included are a chart to tell you exactly where to cut the hole in the ceiling so that the stove will meet clearance requirements, a chart that gives stove clearances for all installations, and a chart to illustrate the required sizes of wall shields for various installations.

Refer to these charts as you plan the installation and do not compromise on any of the dimensions listed.

Clearance Chart Reference Diagrams

Refer to the diagrams below when using the Stove and Chimney Connector Clearance Chart that follows. For example, the letter "A" gives the minimum side clearance for installations in which the stove is not equipped with any heat shield and the wall beside the stove is not protected. "D" gives the minimum side clearance when the stove does not have any heat shield, but the wall is protected.

Measure clearance distances from the top plate of the stove or chimney connector to the wall, not the wall protector.

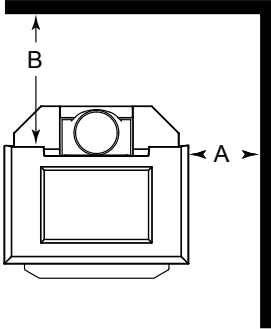
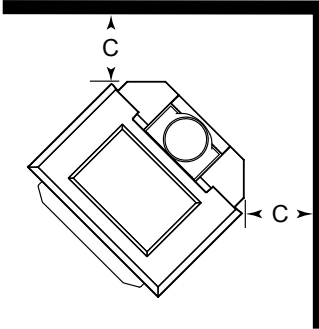
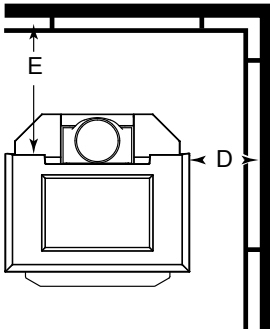
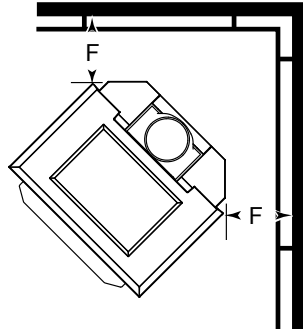
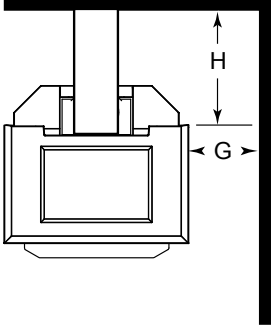
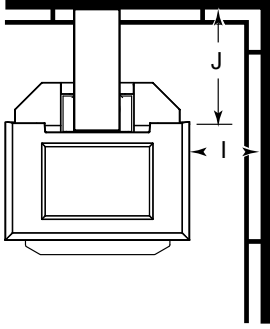
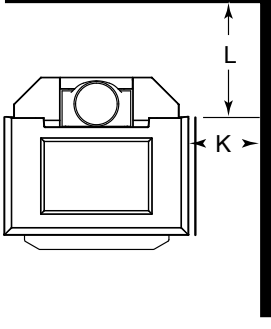
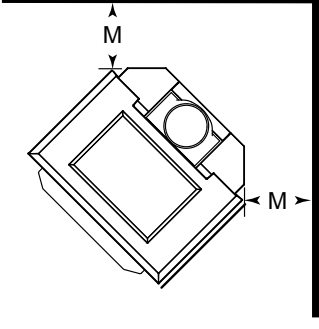
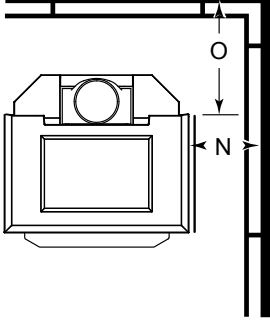
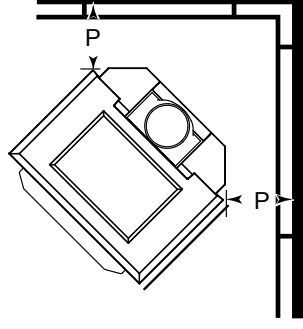
| Unprotected Surface | | Protected Surface | |
|--|---|--|---|
| Parallel Installations | Corner Installations | Parallel Installations | Corner Installations |
|  |  |  |  |
| Installations with no stove heat shields | | | |
|  | N / A |  | N / A |
| Rear exit, flue collar heat shield installations | | | |
|  |  |  |  |
| Top exit, flue collar heat shield, right side heat shield and chimney connector heat shields or double wall connector | | | |

Stove and Chimney Connector Clearance Charts

Model 2478 Medium Convection Heater

| | Unprotected Surface | | | Protected Surface | | |
|---|---|---------------------|-------------------------|--|-------------------------|-------------------------|
| | Parallel Installations | | Corner Installations | Parallel Installations | | Corner Installations |
| Stove Clearance | Side | Rear ³ | Corner | Side | Rear ³ | Corner |
| No heat shields | (A) 20" (508 mm) | (B) 25" (635 mm) | (C) 15-1/2" (394 mm) | (D) 7" (178 mm) | (E) 19" (483 mm) | (F) 10-1/2" (267 mm) |
| Rear exit, flue collar heat shields | (G) 16" (406 mm) | (H) 12" (305 mm) | N/A | N/A | N/A | N/A |
| Top exit ^{1,2} , flue collar single-wall connector w/ connector heat shield and right side heat shield | (K) 14" (356 mm) Right Side Only | (L) 15" (381 mm) | (M) 7-1/2" (191 mm) | (N) 7" (178 mm) Right Side Only | (O) 11" (279 mm) | (P) 7" (178 mm) |
| Top exit ¹ , flue collar heat shield, double wall connector | (K) 17" (432 mm) | (L) 15" (381 mm) | (M) 7-1/2" (191 mm) | (N) 8" (178 mm) | (O) 14-1/2" (368 mm) | (P) 7" (178 mm) |
| Chimney Connector Clearance: | | | | | | |
| Single-wall connector no connector heat shield | 20" (508 mm) | | | 14" (356 mm) | | |
| Single-wall ² connector w/ connector heat shield & flue collar heat shield | 10" (254 mm) | | | 6" (152 mm) | | |
| Double-wall connector & flue collar heat shield | 10" (254 mm) | | | 9-1/2" (241 mm) | | |
| Front Clearance to Combustible: (All Installations) | | | | 48" (1219 mm) | | |

1. Shielding for a top exit stove must include a flue collar shield to protect the area behind the flue collar.
2. Chimney connector heat shields must extend exactly 24" (610 mm) above the flue collar of the stove.
3. Dimension is to the top plate of the stove, not the back wall of the stove.

Important:

When choosing an installation utilizing the side loading door located on the left side of the stove, follow the minimum dimensions given in the Stove and Chimney Connector Chart on Page 13 and the Minimum Dimensions for Noncombustible Floor Protectors given on Page 9, Figure 12.

For operation of the side loading door, the minimum clearances on the left side of the stove for usable operation is 13" (330 mm) in a corner installation and 18" (457 mm) in a parallel installation.

Distance from Center of Flue Collar to Wall in Top-Exit Installations

Dutchwest Convection Heater Model 2478

NOTE: These are not clearance distances. These measurements indicate where the centerline of the flue collar will be for various installations. Measurements are from the centerline of the flue collar to the wall, not the wall protector.

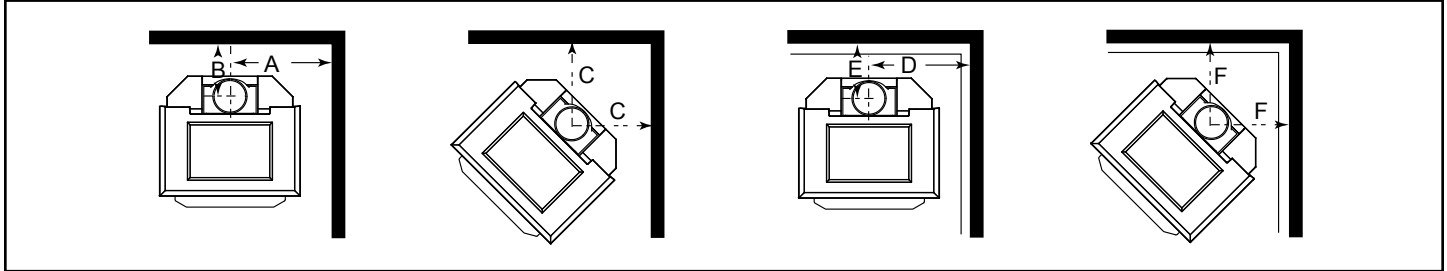

| | Unprotected Surface | | | Protected Surface | | |
|--|------------------------|---------------------|-------------------------|------------------------|-------------------------|-------------------------|
| | Parallel Installations | | Corner Installations | Parallel Installations | | Corner Installations |
| Chimney Connector | Side | Rear | Corner | Side | Rear | Corner |
| Listed, Approved Double-wall, with flue collar shield. | (A) 30" (762 mm) | (B) 13" (330 mm) | (C) 18-1/2" (470 mm) | (D) 21" (533 mm) | (E) 12-1/2" (318 mm) | (F) 18" (457 mm) |
| Single wall, with connector heat shields and flue collar shields | (A) 27" (686 mm) | (B) 13" (330 mm) | (C) 18-1/2" (470 mm) | (D) 20" (508 mm) | (E) 9" (229 mm) | (F) 15" (381 mm) |
| Single wall with no heat shields. | (A) 33" (838 mm) | (B) 23" (584 mm) | (C) 26-1/2" (673 mm) | (D) 20" (508 mm) | (E) 17" (432 mm) | (F) 21-1/2" (546 mm) |

Wall Heat Shield Dimensions

DutchWest Non-Catalytic Convection Heater Model #2478

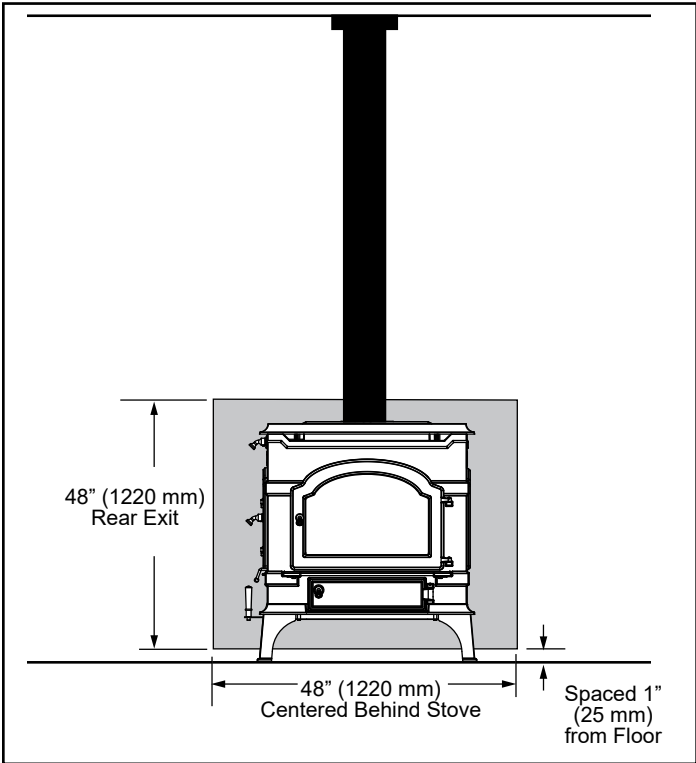

Figure 16 - Rear wall protection.

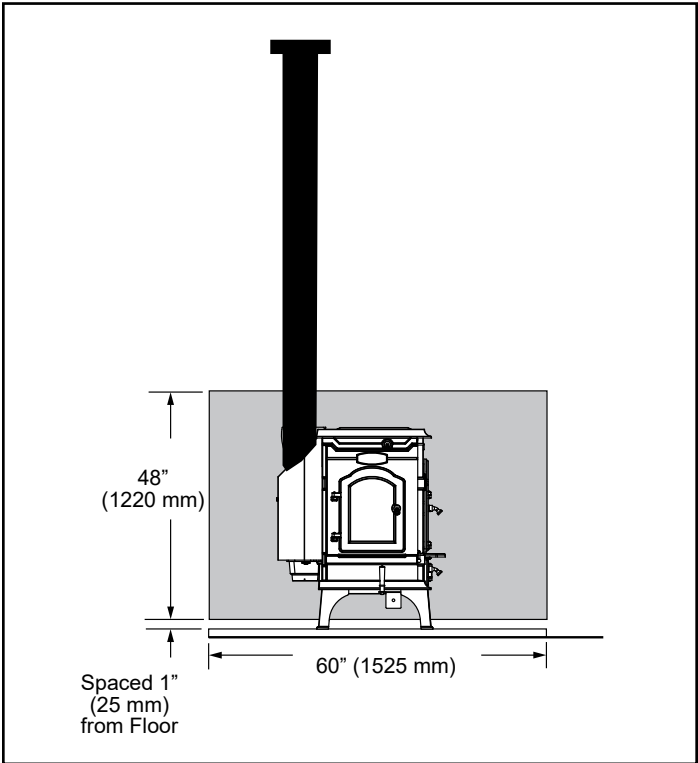

Figure 17 - Sidewall protection.

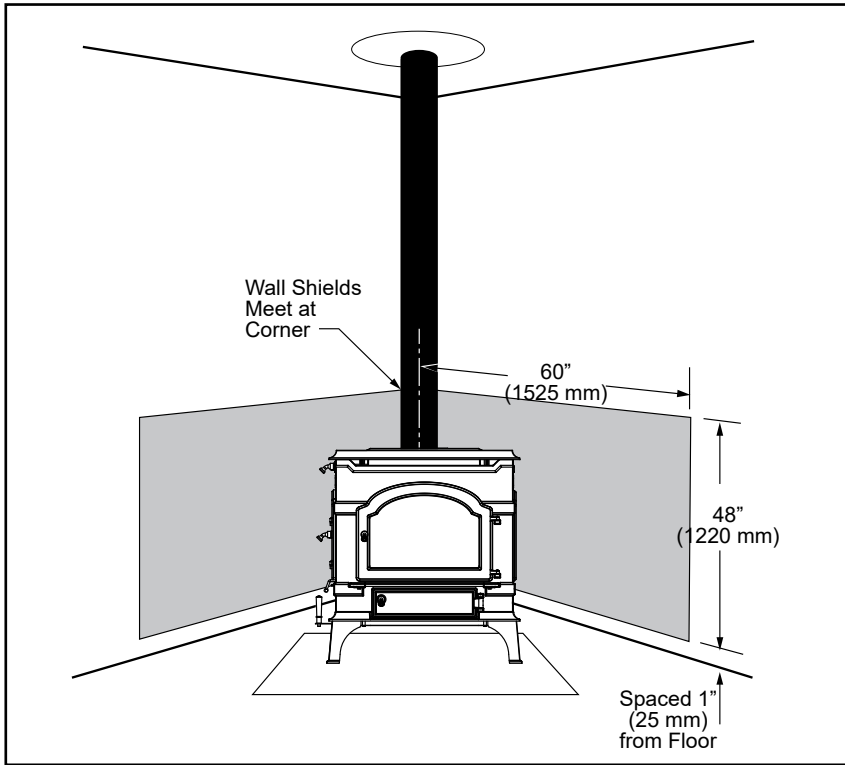

Figure 18 - Corner wall protection.

Assembly

Your convection heater requires some assembly. Follow the directions carefully and refer to the parts diagram at the back of this manual.

Unpack the Parts

Remove the bottom heat shield strapped to the top of the stove and all loose parts from the firebox and the ash pan. Check to make sure all the parts are included and intact. You should have received:

- 1 fully assembled heater body
- 1 bottom heat shield*
- 4 legs
- 1 Lower Load Door Refractory
- 1 ash pan
- 1 handle assembly
- 1 hardware bag, containing the following parts:
 - (3) #10 x 1/2" sheet metal screws, (to attach the chimney connector to the flue collar)
 - (1) 1/8" Allen wrench, (to tighten the door latch)
 - (1) 5/32" Allen wrench, (to tighten the damper handle)
 - (4) washers, (used with the leg bolts to attach legs to the stove)
 - (1) door handle insert holder (for storing the handle assembly when it is not in use.)
 - (4) 3/8-16 x 1" hex head screws, (to attach legs)

If any parts are missing or damaged, immediately notify your Dutchwest dealer for replacements. Do not install your stove without having all necessary parts or using damaged parts.

*** A Bottom Heat Shield is required in many installations. Refer to the floor protection information found in the Installation Section of this manual.**

Attach the Legs and Heat Shield

NOTE: To avoid damaging the sheet metal components, do not place the stove on its back to install the legs. Follow the instructions below.

1. Remove the band that holds the stove to the pallet and remove the bottom heat shield that was positioned on top of the stove. (Figure 19)
2. Rotate the stove counterclockwise until the front left corner overhangs the pallet and the leg-mounting hole is accessible. (Figure 20)
3. Remove and discard the (4) 3/8-16 x 1/2" round head bolts that are in the leg holes on the bottom of the stove.
4. In the hardware bag, locate the four legs, the door handle insert holder, (on this leg only, the door handle insert holder is used along with a washer), (4) 3/8-16 x 1" leg bolts and four (4) washers.

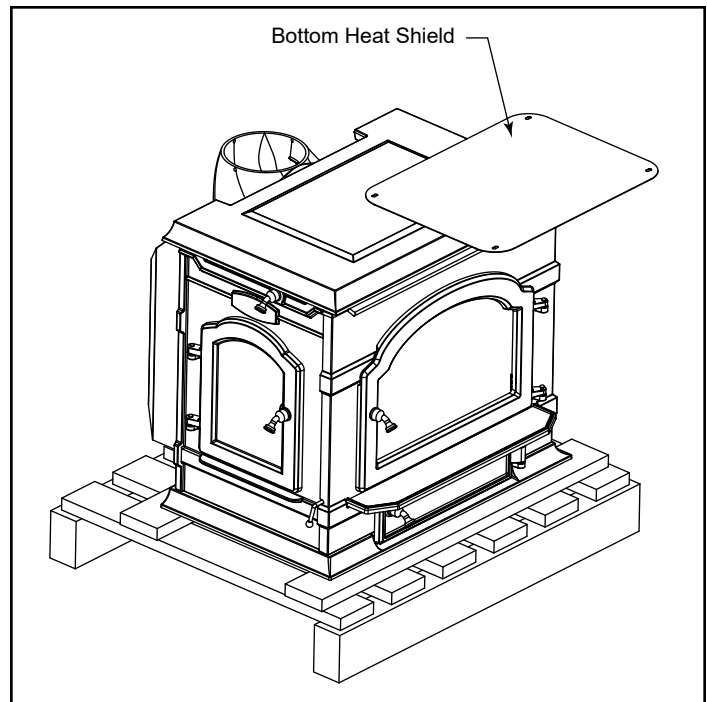

Figure 19 - Remove bands holding stove to pallet and remove heat shield from top of stove.

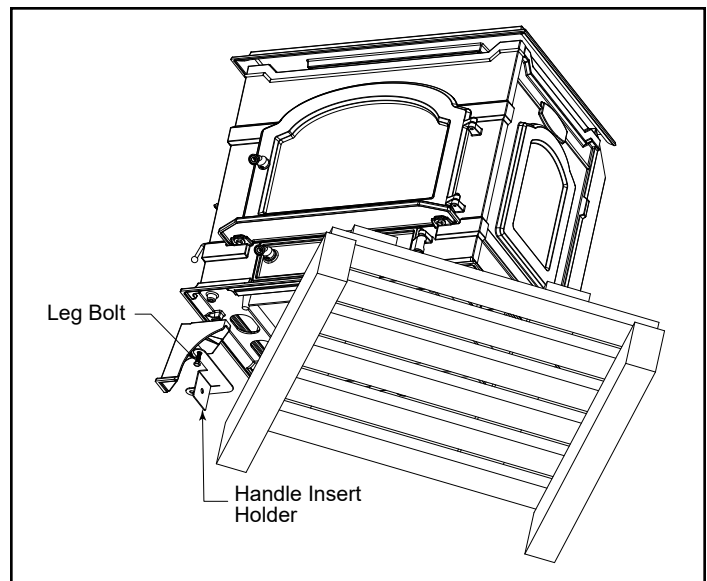

Figure 20 - Rotate stove on pallet to expose front left corner.

5. Place the bolt through a washer and then the door handle insert holder and align the leg with the bolt hole in the bottom of the stove. Tighten securely.
6. Reposition the stove so the other front corner overhangs the pallet and remove the leg bolt from the bottom of the stove. Align the leg with the bolt hole in the bottom of the stove, and attach it with the bolt and washer. Tighten securely.

7. Reposition the stove so the first rear leg can be attached. Attach the leg using the procedure described in Step 6. (Figure 21)
8. Reposition the stove so the remaining leg can be attached. Attach it using the procedure described in Step 6. Remove the pallet from beneath the stove.
9. Remove the (4) 1/4-20 x 3/8" hex head bolts from the mounting bosses and attach the bottom heat shield using the same bolts.

Carefully move the stove to its final position. One way to lessen the effort of moving the stove over smooth flooring is to slide it on a piece of inverted carpet. Move it slowly to ensure the floor is not scratched.

Retighten all leg fastening hardware.

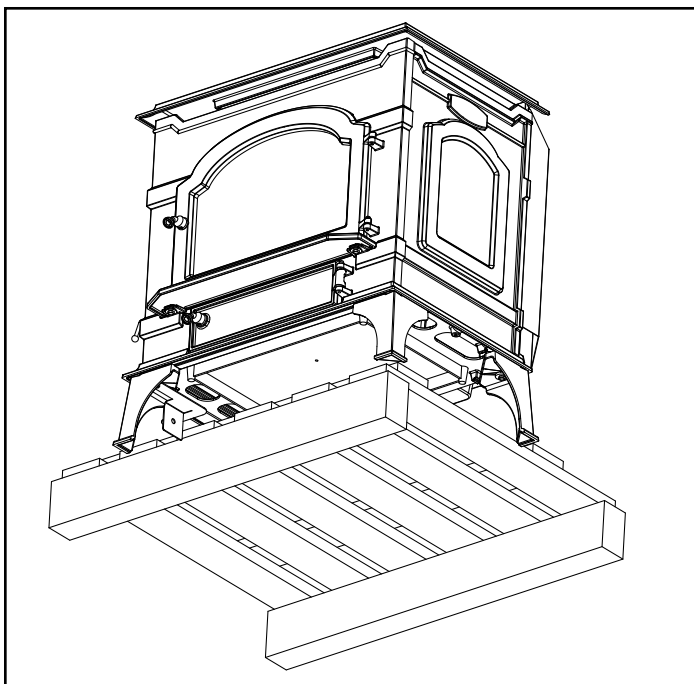

Figure 21 - Reposition stove so one rear leg can be attached.

Install Lower Load Door Refractory

Open the load door and place the lower load door refractory on the bottom and up against the inside of the left end. (Figure 22)

Fan Kit Installation

1. Secure the fan assembly to the inner back with two (2) 1/4-20 x 3/4" hex head screws and one (1) 1/4" star washer as shown in Figure 23.
2. Attach snapstat to the mounting holes on the underside of the bottom with two (2) 1/4-20 pan head screws.

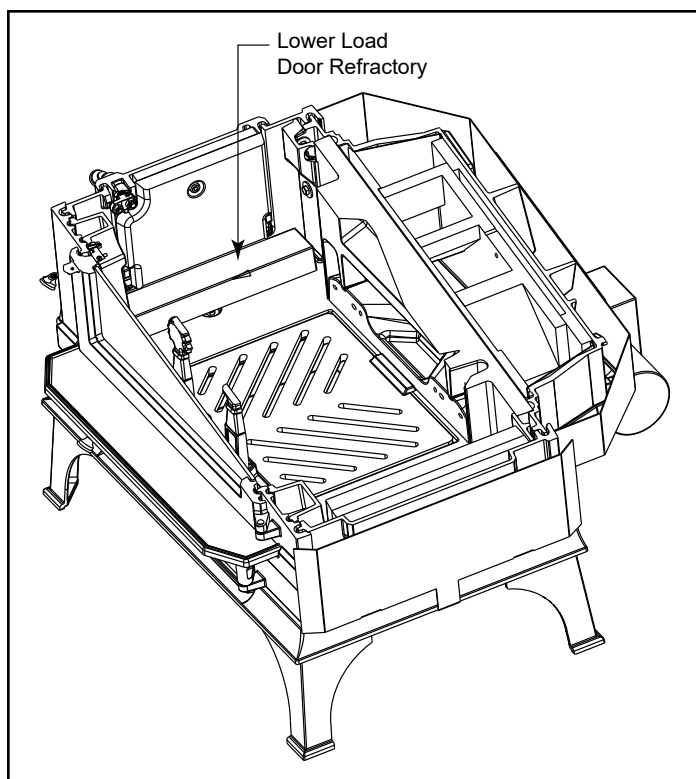

Figure 22 - Install lower load door refractory. (Cutaway view for clarification.)

3. Attach the rheostat to the door handle insert holder near the front left leg. Insert the rheostat control shaft through the handle holder hole. Install the retaining ring and rheostat knob onto the shaft.
4. Place cables where they won't be harmed by traffic.
5. Fan will not operate until stove reaches approximately 109°F.

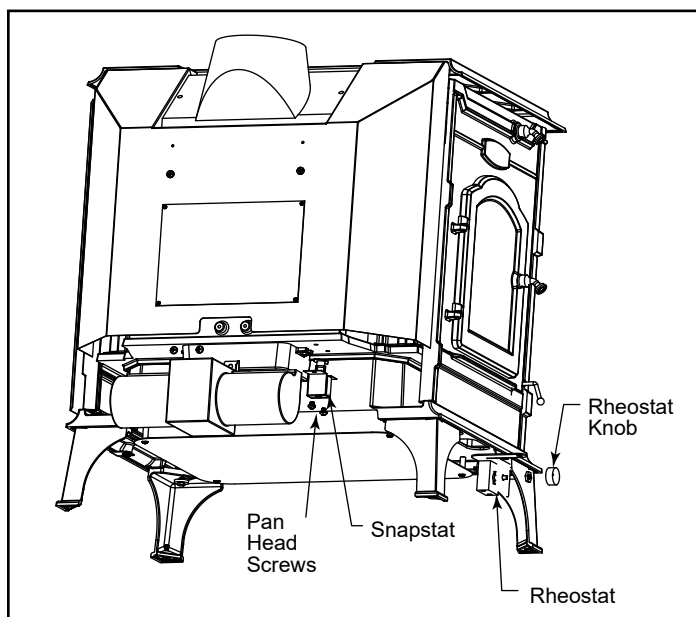

Figure 23 - Fan installation.

Smoke and CO Detectors

The use of smoke and carbon monoxide (CO) detectors throughout the home is strongly advised, even if not required by building codes or insurance regulations. It is a good idea to install a smoke detector in the living areas and each bedroom. Follow the smoke/CO detector manufacturer's placement and installation instructions and maintain regularly.

You may not, however, wish to install a detector in the immediate vicinity of the stove/fireplace insert. Depending on the sensitivity of the unit, the alarm can be set off while you are tending the fire or emptying the ashes. If you install a detector in the same room, locate it as far away from the stove/fireplace insert as possible.

Safety Tips

Conveniently locate a "Class A" fire extinguisher to contend with small fires. Be sure the fire extinguisher works and is clearly visible. All occupants of the house should know where it is, and how it operates. Have heavy stove gloves available near the stove/fireplace insert. Have special safety accessories (e.g., Child Guard Screen) available for use if small children will be in the home.

In the event of a stove pipe or chimney fire....

- Evacuate the house immediately
- Notify the fire department
- If the fire isn't too threatening, closing down the stove/fireplace insert tight, (damper, primary air, all doors) will help to smother the fire.
- Inspect your stove, stove pipe and chimney for any damage caused by the fire and correct any damage before using your stove again.

Operation

Heater Controls and Features Air Control

The Dutchwest Convection Heater Model 2478 has a control that regulates the amount of air drawn into the stove. Generally, more air entering the stove allows the fire to burn hotter and faster, while less air decreases heat output and prolongs the overall burn time.

The **Air Control Lever** is located at the lower front edge of the left side (looking from the front of the stove). (Figure 24) The lever operates two internal shutters. Opening the inlet shutters provides air for primary combustion.

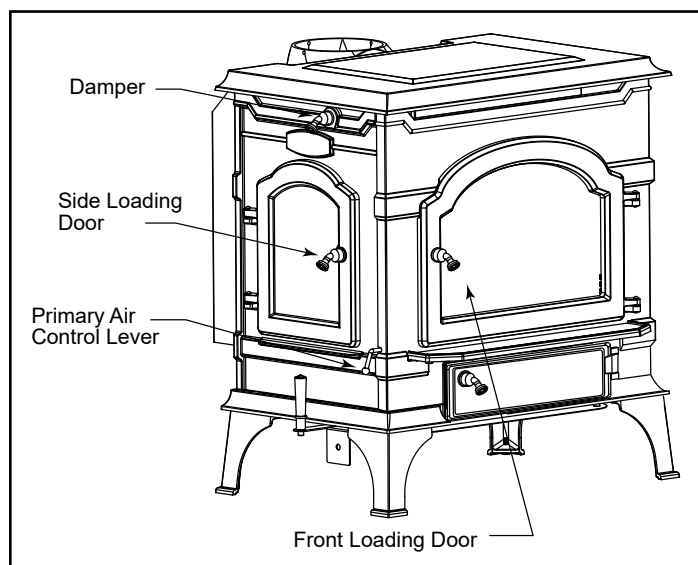

Figure 24 - The heater controls.

To open the shutters, turn the lever clockwise. The shutters are all the way open when the lever points toward the rear at a “9:00” position. (Figure 25) To close the shutters, turn the lever counterclockwise. The shutters are fully closed when the lever points straight down. (Figure 26)

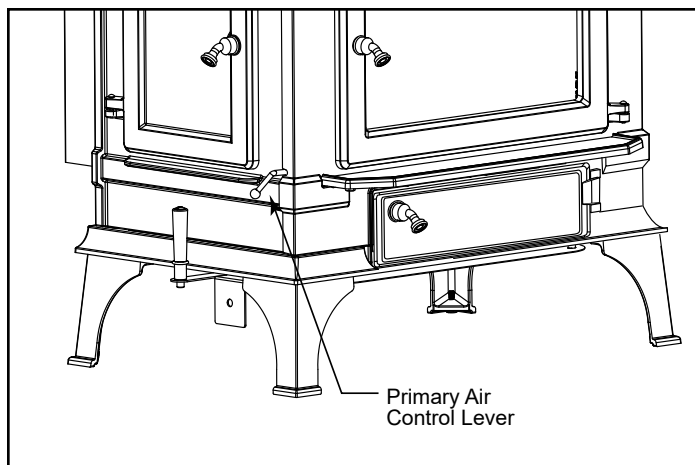

Figure 25 - Turn primary air control lever clockwise to open.

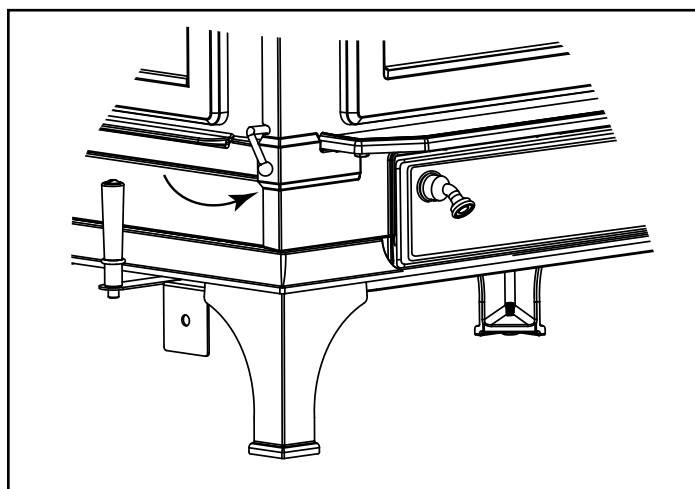

Figure 26 - Turn primary air control lever counterclockwise to close.



WARNING

This wood heater has a manufactured-set minimum low burn rate that must not be altered. It is against federal regulations to alter this setting or otherwise operate this wood heater in a manner inconsistent with operating instructions in this manual.

Damper Function

The **Damper** is operated by moving the handle on the upper left side of the stove. (Figure 27) It has two positions: **OPEN**, to start the fire and load fuel, and **CLOSED**, for greatest efficiency and heat. When the damper is closed, exhaust gases travel through a secondary combustion chamber at the rear of the stove before flowing into the chimney.

Use the door insert handle to rotate the damper handle. Turn it counterclockwise to open the damper and clockwise to close it. You will feel resistance as the damper mechanism engages into the open (counterclockwise) position.

The stove damper must be open when you start a fire, load fuel, or before you open either door for any reason.

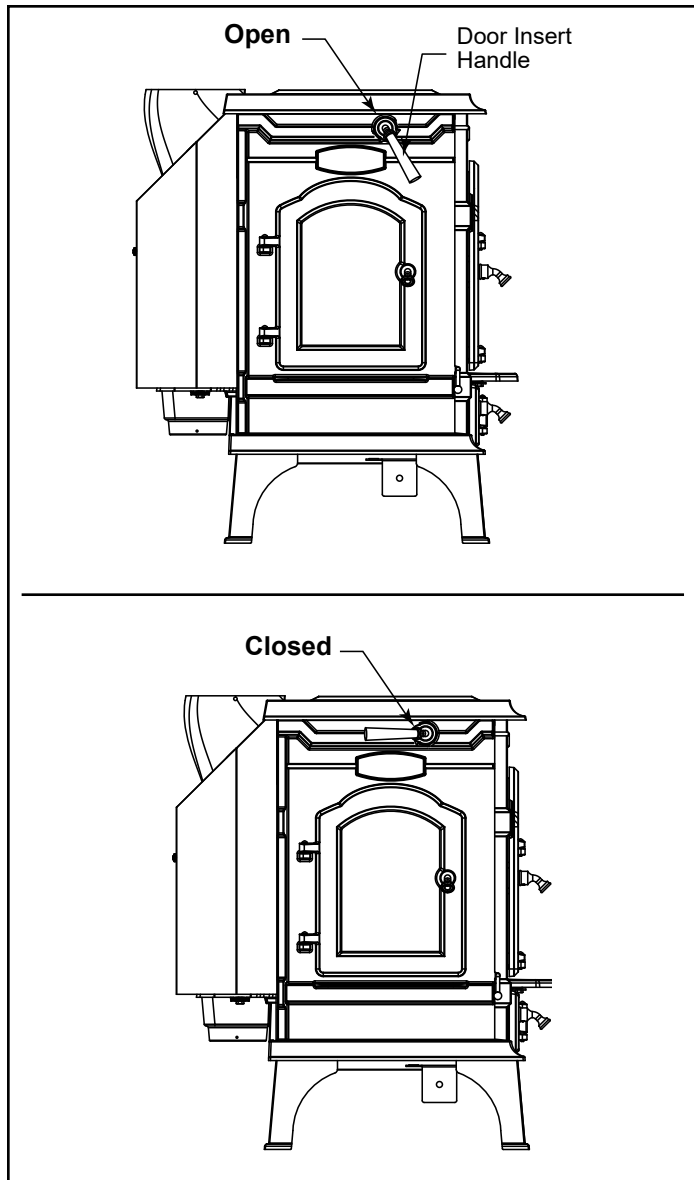

Figure 27 - Damper operating positions.

Load Doors

A **Side Loading Door** allows the easiest loading of wood logs. The **Front Door** opens for adding an occasional log to the fire. Always be sure to open the stove damper before opening either door.

Successful Wood Burning

Woodburning is often said to be more of an art than a science. You'll easily master the art if you start by using good, dry fuel and by understanding how the stove's air supply system operates.

Burn Only High-Quality Fuel

Your heater is designed to burn natural wood only. Do not burn other fuels. Never burn pressure-treated wood, painted or stained wood, or glossy newsprint.

High efficiencies and low emissions are only possible when burning air-dried, seasoned woods. Avoid burning "green" wood that has not been properly seasoned.

The best hardwood fuels include oak, maple, beech, ash, and hickory that has been split, stacked, and air-dried outside under cover for at least one year. If hardwood is not available, tamarack, yellow pine, white pine, Eastern red cedar, fir, and redwood are softwoods that are commonly burned. They too should be properly dried. The length of the wood should be the same as that specified for your particular stove. Avoid using wood that has been dried more than two years. Often gray in color, this wood burns very quickly, resulting in short burn time and diminished stove performance. If you must burn it, mix it in with greener wood to slow the burn.

Store your firewood under cover to keep it dry. Even for short-term storage, keep wood outside of the heater's installation clearances and outside of the space around the heater required for refueling and ash removal.

Use the Air Control Settings that Work Best for You

No single control setting will fit every situation. Each installation will differ depending on the quality of the fuel, the amount of heat desired, and how long you wish the fire to burn.

Control settings also depend on your particular installation's "draft," or the force that moves air from the stove up through the chimney. Draft is affected by such things as the height, type, and location of the chimney, local geography, nearby obstructions, and other factors.

Too much draft may cause excessive temperatures in the stove. On the other hand, too little draft can cause backpuffing into the room and/or insufficient heat.

How do you know if your draft is excessively high or low? Symptoms of too much draft include an uncontrollable burn or a part of the stove or chimney connector glowing-red. Inadequate draft may be indicated by smoke leaking into the room through the stove or chimney connector joints.

When first using the stove, keep a record of the results you achieve from different control settings. You will find that specific settings will give you a fixed amount of heat. It may take a week or two to determine the amount of heat and the length of burn you should expect from various control settings.

Notice that changes in the weather have a strong effect on chimney draft. Higher outdoor temperatures and lower air pressure both weaken draft; lower temperatures and higher air pressure encourage a stronger draft. An exception to this is in installations with outdoor chimneys; since these lose heat to the outdoors, it takes longer to warm them up initially, and it takes more heat to keep them warm, especially when temperatures are very low outdoors.

Most installations do not require a large amount of combustion air, especially if adequate draft is available. Do not attempt to increase the firing rate of your heater by altering the air control adjustment range outlined in these directions.

In some newer homes that are well insulated and weather-tight, poor draft may result from insufficient air in the house. In such instances, an open window near the stove on the windward side of the house (side against which the wind is blowing) will provide the fresh air needed. Another solution is to equip the stove with an Outside Air Kit, available from your local dealer.

Use the air control settings indicated in Figure 28 as a starting point to help determine the best settings for your installation.

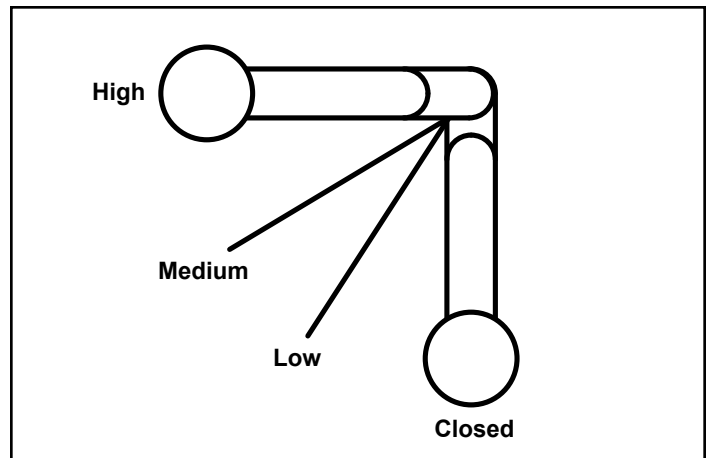

Figure 28 - Position the primary air control lever for different burn rates.

DO NOT OPERATE THE STOVE WITH THE ASH DOOR OPEN. OPERATION WITH THE ASH DOOR OPEN CAN CAUSE AN OVER-FIRING CONDITION TO OCCUR. OVER-FIRING THE STOVE IS DANGEROUS AND CAN RESULT IN PROPERTY DAMAGE, INJURY, OR LOSS OF LIFE.

How to Build and Maintain a Wood Fire

Loading Wood

You can load wood into your Dutchwest Convection Heater through either the front or side doors. Front loading is useful for kindling a new fire and adding an occasional log; however, we recommend side-loading as most convenient when adding several logs at a time. Always be certain that the stove damper is open before opening either door.

WARNING: OPERATE YOUR DUTCHWEST CONVECTION HEATER ONLY WITH THE DOORS FULLY CLOSED EXCEPT WHEN REFUELING.

THIS STOVE IS HOT WHILE IN OPERATION! KEEP CHILDREN, CLOTHING, AND FURNITURE AWAY. CONTACT MAY CAUSE SKIN BURNS.

Break-in Fires

If your stove is new or has new cast iron replacement parts, "season" the new cast iron with a few break-in fires. Follow Steps 1-3 below. Then let the fire burn out. Do not close the damper. Maintain a small but not smoky fire by adjusting the air control. After the break-in fires, continue with Step 4.

The stove's paint and cement will emit a slight odor as these materials cure during the first few fires. You may wish to provide extra ventilation near the stove by partially opening a door or window until the odor disappears.

Lighting the Fire

Step 1. Open the stove damper. Open the primary air control fully.

Step 2. Lay some crumpled newspapers in the stove. Place six or eight finger-width size pieces of dry kindling on the paper. On the kindling, lay two or three larger sticks of split dry wood approximately 1-2" (25-50 mm) thick.

DO NOT USE CHEMICALS OR FLUIDS TO START THE FIRE. DO NOT BURN GARBAGE OR FLAMMABLE FLUIDS SUCH AS GASOLINE, NAPHTHA, OR ENGINE OIL.

Also, never use gasoline-type lantern fuel, kerosene, charcoal lighter fluid, or similar liquids to start or "freshen up" a fire in this heater. Keep all such liquids well away from the heater while it is in use.

Step 3. Light the newspaper and close the door. The fire soon will be well-established and you may gradually build it up by adding a few sticks at a time of a progressively larger size. For your initial three or four break-in fires, let the fire burn brightly for a short time, then let it die out. **NOTE:** An especially large, outdoor, or cold chimney may need to be "primed," or warmed up, before it will draw sufficiently to start a fire. If this is the case, roll up a couple pieces of newspaper, place them on top of the kindling and toward the back of the stove, light them, and close the doors. This should heat the chimney enough to initiate a draft.

Once the draft is established, open the front door and light the rest of the fuel from the bottom. Do not light the main bed of fuel until the chimney begins drawing. Repeat the procedure as often as necessary if the initial attempt is unsuccessful.

Step 4. Once the fire is burning steadily, continue adding fuel until a thick bed has been established on the grate. The bed should be about 2" (51 mm) deep and should cover the throat opening into the secondary combustion chamber that is located in the lower center fireback.

Step 5. Once the ember bed is formed, prepare the stove for high-efficiency operation. Load it with fuel, first with smaller splits of wood and then larger ones.

Close the damper and set the air control lever to the "HIGH" position. Operate the stove for 15-20 minutes at this maximum air setting to guarantee the new load of fuel has fully ignited. Once the fuel is burning steadily, you may adjust the air supply to provide the desired heat output. Refer back to the air control settings chart on Page 20.

NOTE: Effectiveness of a "top-down" method to start a fire. Smoke emissions when starting a fire can be difficult to control because the stove is not yet heated to its optimum temperature. One method of reducing emissions during a cold start-up is the use of a "top-down" kindling procedure. In this, place larger pieces of kindling on the bottom of the kindling pile followed by smaller and smaller pieces as the pile is added to. Very finely split pieces should be on the top. Light the kindling pile with a match at the top and allow the kindling to burn downward into the larger pieces. This reduces smoke by slowly increasing the fire size without creating an air-starved condition.

You'll soon find that this stove is **HOT WHILE IN OPERATION! KEEP CHILDREN, CLOTHING, AND FURNITURE AWAY. CONTACT MAY CAUSE SKIN BURNS.**

DO NOT Over-fire THIS HEATER. Overfiring may cause a house fire, or can result in permanent damage to the stove. If a part of the stove or the chimney connector glows, you are overfiring.

Reloading and Reviving the Fire

Reload your stove while it is still hot and there are plenty of embers to re-ignite the fire quickly. Include some smaller pieces of wood in the new load of fuel to help the stove regain high temperatures quickly.

Follow this procedure when you reload the stove:

- Open the damper and move the primary air lever to the "HIGH" position.
- Open the front door and check the ash level on the grates and in the ash pan. Clear excess ash from the grates, particularly at the rear area. Level the ember bed. Empty the ash pan if necessary.
- Replace the ash pan and close the front door.
- Load wood, smaller pieces first, and close the loading door.
- Allow the stove to regain its "thermal momentum" before closing the damper. This may take 15-20 minutes.
- Close the damper and set the air control lever for the desired heat output.

NOTE: If the charcoal bed is relatively thick and your fuel is well-seasoned, it is possible to add fresh fuel (smaller pieces first), close the door and damper, and reset the air control within five minutes.

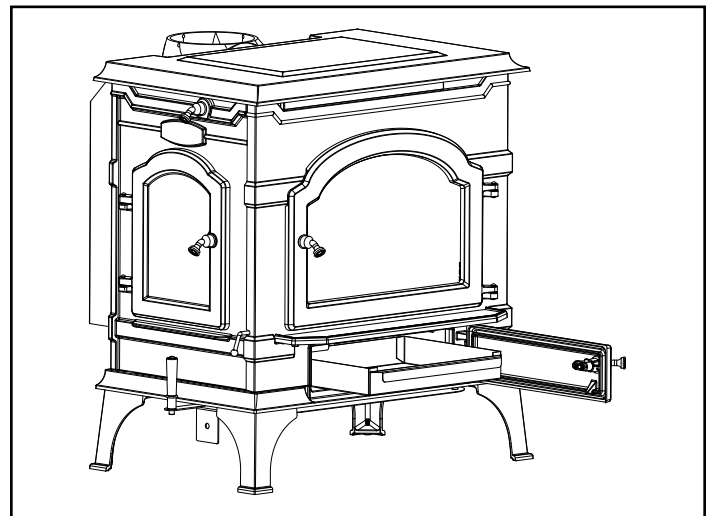

Figure 29 - Check the ash compartment before reloading the stove.

Remove Ashes Frequently

Wear heavy stove gloves when removing ashes. Check the ash compartment before reloading the stove. If the ash pan is nearly full, empty the pan. Before replacing the ash pan, clear away any ash that may have spilled over the sides and back of the pan.

Empty the ash drawer regularly - typically every one to three days. The frequency will vary depending on what kind of wood you use and how hot you run your stove—the hotter the fire, the more wood you burn, and the faster ash will accumulate.

Safe Ash Handling

Ashes may contain hot coals and must be treated with extreme care. Ashes should be placed outdoors in a metal container with a tight-fitting lid. The closed container of ashes should be placed on a noncombustible floor or on the ground, well away from all combustible materials, pending final disposal. If the ashes are disposed of by burial in soil or otherwise locally dispersed, keep them in the closed container until all cinders have thoroughly cooled. **Note:** It may take days for these coals to stop burning. Wood ash may be used as a garden fertilizer.



CAUTION

Never use a vacuum cleaner to remove ash from the stove; always remove and dispose of the ashes properly.

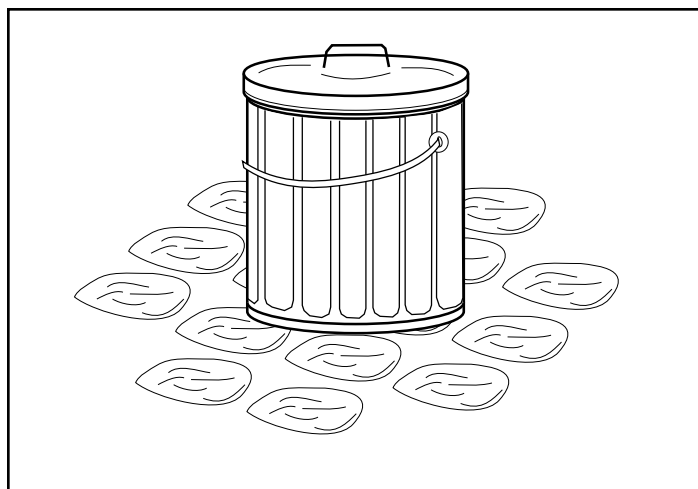

Figure 30 - Hot ashes can be dangerous and must be stored outdoors on a noncombustible surface in a metal container with a tight-fitting lid.

Maintenance

Keep Your Stove Looking New And Working Its Best

Care of the Cast Iron Surface

An occasional dusting with a dry rag will keep the painted cast iron of your Dutchwest Convection Heater looking new.

If the paint needs retouching, allow the stove to cool completely. Wire-brush areas needing to be painted. Remove non-painted components such as air controls or cover them with masking tape. Touch up the stove with high temperature stove paint available from your local dealer. Apply the paint sparingly. Two light coats are better than one heavy one.

Cleaning the Glass

You will find that most of the carbon deposits on the glass will burn off regularly during hot fires. You can wipe fly ash from the glass when hot using a crumpled piece of dry newspaper.

Never use liquid cleaning agents on hot glass. If you wish to clean the glass more thoroughly, follow this procedure:

- Be sure the glass is completely cool.
- Use a glass cleaner especially made for this purpose.
- Dry the glass completely.

Adjust the Door Latch

The door latches must close tightly to ensure a good seal between the each door and the stove plates. With time and use, the door latches will require periodic adjustment. Follow this procedure: (Figure 31)

1. Loosen the small locking nut with an open end wrench.
2. Use the allen wrench (included with the stove) to turn the striker screw clockwise one quarter-turn and close the door to test the engagement. The door latch should engage tightly when closed. Make further adjustments in small increments.
3. When the striker screw is properly adjusted, tighten the small locking nut against the pawl without allowing the striker screw to turn.

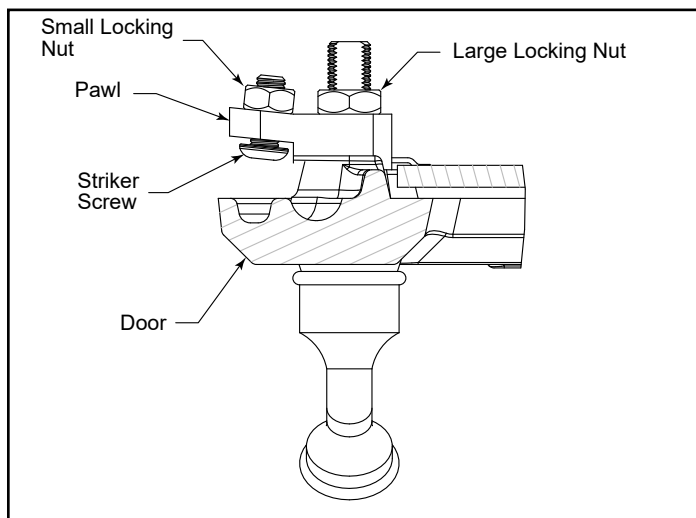

Figure 31 - Door latch adjustment.

Test and Repair the Door Gaskets

Air leaks can be caused by low spots in the door gaskets. To locate such low spots, close each door on a slip of paper and attempt to pull the paper free. If the paper slips out without tearing, the gasket isn't snug enough at that spot.

If the seal cannot be improved by adjusting the door latch, try shimming the gasket. Pack a small quantity of cement or a smaller diameter gasket into the channel beneath the gasket to lift the main gasket and thereby improve its contact with the door frame.

If shimming does not improve the seal, replace the gasket following these steps:

1. Remove the original gasket by grasping an end and pulling firmly.
2. Wearing safety goggles, use a wire brush or the tip of a screwdriver to clean the channel of any remaining cement or bits of gasket.
3. Apply a thin bead of stove cement in the newly-cleaned groove.
4. Lay the gasket into the groove. Wait until you are a couple inches from the end before you cut it.
5. Test the gasket by closing the door on a slip of paper as described above. Adjust the gasket in any areas where an inadequate seal is evident.

All rope-type gasketing used in the Dutchwest Convection Heater is made of fiberglass. The gasket is 3/8" diameter for front and side doors and the ash door and 3/8" for the top plate. 3/16" gasket is used behind the glass.

Avoid Damaging the Glass Door Panel

Do not abuse the glass by slamming the door or striking the glass with a log. Never operate your stove if it has damaged or broken glass. If you need to replace the glass, use only replacement glass provided by your local Dutchwest dealer.

Damper Adjustment

With time, you may need to adjust the damper linkage to ensure that the damper plate seals tightly when closed. Test the damper when the stove is cold. When turned into the closed position, the damper should feel “snug” but not too tight. It will become a little tighter as the stove heats up. Use a 7/16” socket wrench with socket extension to adjust the linkage:

1. From inside the stove, first loosen and then remove the two (2) nuts on the threaded rods that secure the top plate to the inner top of the stove.
2. Remove the top plate and open the damper.
3. Loosen the adjusting bolt's lock nut. (Figure 33)
4. Loosen the anchor bolt's lock nut, located on the underside of the damper.
5. Loosen the anchor bolt a turn or two.
6. Tighten the adjusting bolt.
7. Test the damper. Make further adjustments if necessary.
8. When final adjustment has been made, tighten the adjusting bolt lock nut, the anchor bolt, and the anchor bolt lock nut.

Primary Air Control Adjustment

Simple spring-loaded tabs maintain tension on the primary air control lever. The air control should be loose enough for you to easily set its position by hand, but also snug enough to remain in that position until you change it.

Over time, the air control may tighten or loosen. To adjust the tension on the control, let the stove cool to room temperature. Open the side-loading door and look in toward the inner side of the front panel of the stove. (Figure 34) Locate the lower hex head bolts (A) on the primary air manifold rods on either side of the door. Adjust with a 7/16” wrench.

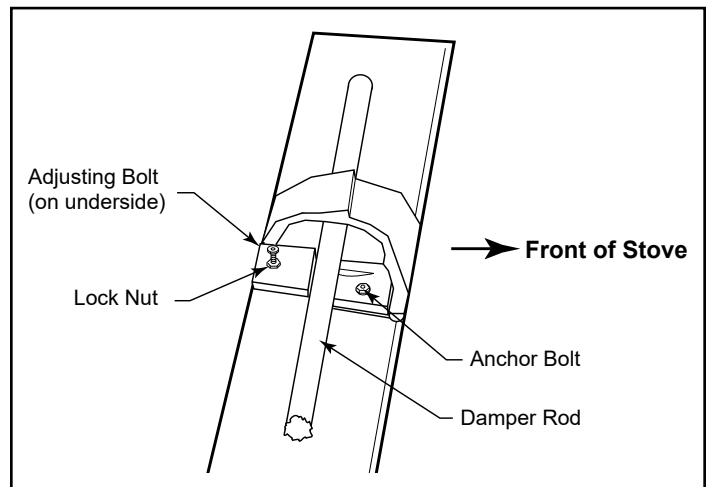

Figure 33 - Damper adjustment.

Note that the mechanism may tighten slightly as the stove heats up. Your adjustment should leave the air control snug, but not overly tight.

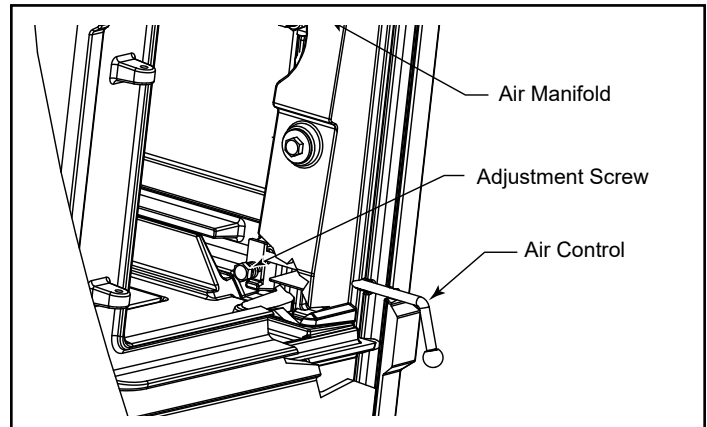

Figure 34 - Primary air control adjustment.

Cleaning the Chimney System

The chimney system is composed of the chimney and the pipe that connects the stove to the chimney. Inspect the chimney and chimney connector at least twice monthly, and clean if necessary.

When you first begin using the stove, check daily for creosote — a substance that can look like either thick tar or black, crisp flakes. Experience will show how often you need to clean to be safe. The frequency may even vary during the year. In the colder months when the hottest fires producing the least creosote are burned, you may need to clean only every couple of months. During the warmer months when creosote is more likely to result from cooler-burning fires, weekly cleaning may be necessary.

At the very least, inspect the chimney connector and chimney at least once every two months during the heating season to determine if a buildup of creosote or soot has occurred. If a significant layer of creosote has accumulated (1/8" [3 mm] or more), or if soot has accumulated, either should be removed to reduce the risk of a chimney fire. Failure to keep the chimney and connector system clean can result in a serious chimney fire.

The conditions for a chimney fire develop as follows: When wood is burned slowly, it produces tar and other organic vapors which combine with expelled moisture to form creosote. The creosote vapors condense in the relatively cool chimney flue of a slow-burning fire. As a result, creosote residue accumulates on the flue lining. Creosote is flammable and, when ignited, makes an extremely hot fire within the flue system which can damage the chimney and overheat adjacent combustible material.

To reduce the amount of creosote that may form, remember to provide adequate air for combustion and to strive for small, intense fires rather than large, smoldering ones.

You can never be too safe. Contact your local fire authority for information on what to do in the event of a chimney fire, and have a clearly understood plan on how to handle one.

Inspect Regularly, Clean As Required

Inspect the chimney and chimney connector twice monthly and clean if necessary. Let the stove cool completely before you inspect the chimney. Use a flashlight and mirror to sight up the flue through the chimney clean-out door or chimney connector inspection tee. If no inspection access is available, disconnect the pipe from the stove.

Clean the chimney using a specially designed chimney cleaning brush, the same size and shape as the flue liner, attached to flexible fiberglass rods designed for this purpose. Run the brush up and down the liner so that any deposits fall to the bottom of the chimney where they can be removed through the clean-out door.

Clean the chimney connector by disconnecting the sections, taking them outside, and removing any deposits with a stiff wire brush. You can use a chimney brush of correct size to clean chimney connector pipe. Reinstall the connector sections after cleaning, being sure to secure the individual sections with three sheet metal screws per section.

If you are unable to inspect and/or clean the chimney system yourself, contact your local Dutchwest dealer or hire a qualified chimney sweep in your area to do the job.

Maintenance Schedule - The Stove

Daily:

- Clear any ash build-up from around the air holes and combustion flow path in the lower fireback.
- Ashes should be removed before they reach the top of the ash pan. Check accumulation at least once a day.
- Keep the area around the stove clear of any combustible materials such as wood, furniture or clothing.

Two Months:

- Check door handle to be sure it is working properly. Gasketing becomes compressed after a period of time. Adjust handle tightness if necessary.
- Check leg bolts and heat shield screws; tighten if necessary.

Annual Spring Cleaning:

- Check gasketing for wear, and replace if necessary.
- Remove ashes from the ash pan and replace with a moisture absorbing material (such as kitty litter) to keep the interior of the stove dry.
- Clean the dust from the inner sides of bottom, rear or pipe heat shields if your stove is equipped with them. Clean surfaces are better heat reflectors than dirty surfaces.
- Touch up the black paint.
- Inspect for and remove ash build-up behind the combustion package. This should be done in conjunction with annual cleaning of the chimney connector since this inspection is most conveniently done through the flue collar opening. Inspect the passages to either side of the combustion package (a mirror will be helpful) and vacuum away ash using a flexible vacuum hose inserted into each passage. Care should be taken not to damage the white fibrous material in this rear chamber. (Figure 35)

The Chimney Connector

Two Weeks:

- Inspect the chimney connector and chimney. Clean if necessary.

Two Months:

- Inspect the chimney and chimney connector. Pay particular attention to the horizontal runs of chimney connector, and the elbows. Clean the system if necessary.

Annual Spring Cleaning:

- Disassemble the chimney connector and take it outdoors for inspection and cleaning. Replace weak sections of connector.
- Inspect the chimney for signs of deterioration. Repairs to a masonry chimney should be made by a professional mason. Replace damaged sections of prefabricated chimney. Your local Dutchwest dealer or a chimney sweep can help determine when replacement is necessary.
- Thoroughly clean the chimney.

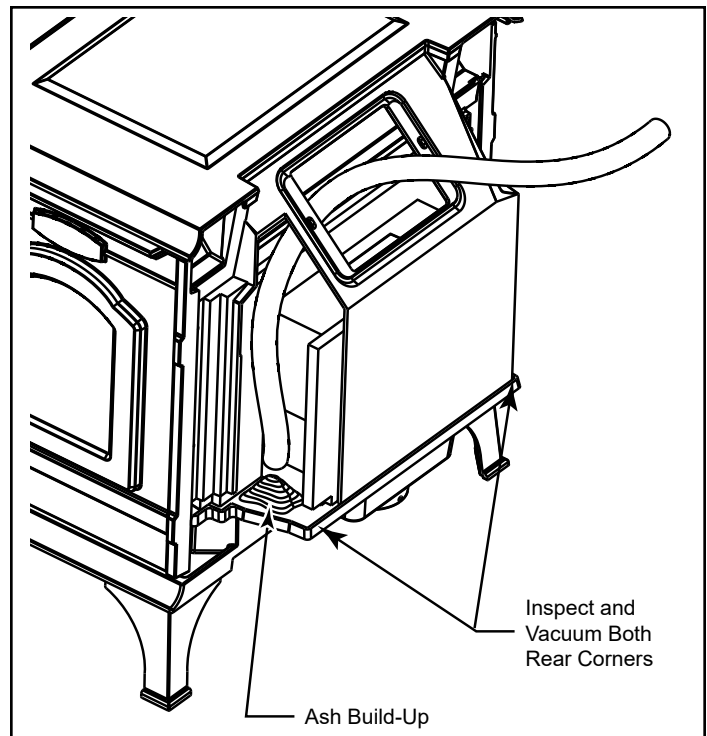

Figure 35 - Inspect and clean out ash accumulation on either side of the non-catalytic combustion system.

Draft Management

Your stove is only one part of a system that includes the chimney, the operator, the fuel, and the home. The other parts of the system will affect how well the stove works. When there is a good match between all the parts, the system works well.

Wood stove operation depends on natural (unforced) draft. Natural draft occurs when exhaust gas is hotter (and therefore lighter) than the outdoor air at the top of the chimney. The greater the temperature difference, the stronger the draft. As the hot exhaust gas rises out of the chimney, it generates suction that draws air into the stove for combustion. A slow, lazy fire when the stove's air inlets are fully open indicates a weak draft. A brisk fire, supported only by air entering the stove through the air inlets, indicates a good draft. The inlets are passive; they regulate how much air can enter the stove, but they don't force air into it.

The efficiency of a modern woodburning appliance, (in which the amount of air available for combustion is regulated), depends on the chimney to keep exhaust gases warm all the way outdoors. The characteristics of your chimney - whether it is steel or masonry, interior or exterior, matched or mismatched to the stove outlet, - determine how quickly it will warm up and how well it will sustain the optimum temperatures necessary to maintain strong draft and efficient combustion. Here follows a description of various flue system characteristics and the related effects on stove performance.

Masonry Chimney

Although masonry is the traditional material used for chimney construction, it can have distinct performance disadvantages when used to vent a controlled-combustion woodstove. Masonry forms an effective 'heat sink' - that is, it absorbs and holds heat for long periods of time.

The large mass, however, may take a long time to become hot enough to sustain a strong draft. The larger the chimney (in total mass), the longer it will take to warm up. Cold masonry will actually cool exhaust gases enough to diminish draft strength. This problem is worse if the chimney is located outside the home or if the chimney flue has a cross-sectional volume much larger than the stove outlet.

Steel Chimney

Most factory-made 'Class A' steel chimneys have a layer of insulation around the inner flue. This insulation keeps the smoke warm and protects the surrounding structure from the high flue temperatures. Because the insulation is less dense than masonry, the inner steel liner warms up more quickly than a masonry chimney; this makes the steel chimney support a good draft more quickly than masonry does. Steel chimneys are not as attractive as masonry, but they are very durable and generally outperform masonry.

Indoor/ Outdoor Location

Because the chimney's function is to keep the smoke warm, it is best to locate it inside the house. This location uses the house as insulation for the flue and allows some radiant heat release from the flue into the home. Since an interior chimney doesn't continuously lose its heat to the outdoors, less heat from the stove is required to get it warm and keep it warm.

Flue Sizing

The flue size for a controlled-combustion appliance should be based on the cross-sectional volume of the stove flue outlet. In this case, more is definitely not better. Hot gases lose heat through expansion; if a stove with a six-inch flue collar (28 square inch area) is vented into a 10" x 10" flue, the gases will expand to over three times their original volume. As gases cool with expansion, draft strength decreases. If an oversized flue is also outside the house, the heat it absorbs will be conducted to the outdoor air and the flue will remain relatively cool.

It is common for a masonry flue to be oversized for the stove. Such a chimney can take quite a while to warm up and the stove performance will likely be disappointing. The best solution to an oversize flue problem is the installation of an insulated steel chimney liner of the same diameter as the appliance flue outlet. The liner keeps the exhaust gas warm and the result is a stronger draft. An uninsulated liner is a second choice - although the liner will keep the exhaust restricted to its original volume, the air around the liner will require time and heat energy to warm up.

Check your local codes. You may be required to install a flue liner in any oversize or masonry flue.

Pipe & Chimney Layout

Every bend in the flue will act as a brake on the exhaust as it flows from the firebox to the chimney cap. The ideal pipe and chimney keeps some pipe in the room for heat transfer, and allows long-term flexibility for installing a different appliance without relocating the thimble.

There should be no more than eight feet of single-wall stove pipe between the stove and a chimney. Longer runs can cool the smoke enough to cause draft and creosote problems. Use double-wall stove pipe for longer runs.

Single Venting

Your stove requires a dedicated flue. Do not connect the stove to a flue used by any other appliance. Chimney draft is a natural form of energy and follows the path of least resistance. If the stove is vented to a flue that also serves an open fireplace or another appliance, the draft will also pull air in through those avenues.

The additional air flow will lower flue temperatures, reduce draft strength and promote creosote development; overall stove performance will suffer. The effect is similar to that of a vacuum cleaner with a hole in the hose. In some extreme instances, the other appliance can even impose a negative draft and result in a dangerous draft reversal.

Fuel

Even the best stove installation will not perform well with poor fuel. If available, always use hardwood that has been air-dried (“seasoned”) 12-18 months. Softwood burns more rapidly than hardwood and has a high pitch content that can result in creosote. Decayed wood of any type has little heat value and should not be used.

Unseasoned (‘green’) wood has a high moisture content. Much of its heat value will be used to evaporate moisture before the wood can burn. This significantly reduces the amount of energy available to warm your home, as well as the intensity of the fire and temperature of the exhaust gas. Incomplete combustion and cool flue temperatures promote creosote formation and weak draft.

You can judge the moisture content of wood by its appearance and weight or use a commercially available moisture meter for an exact measurement. Unseasoned wood will be a third heavier than dry wood. Also, look for cracks (“checking”) in the ends of the log that result from contraction as the wood dries. The longer and wider the cracks are, the dryer the wood is.

Creosote

Creosote is a by-product of low-temperature stove operation, weak draft, or both. It is a tar that results when unburned gases condense inside the flue system at temperatures below 290° F. Creosote is volatile and can generate a chimney fire. All of the installation characteristics that adversely affect chimney draft also promote creosote condensation. Consequently, you can minimize creosote accumulation with an effective chimney design and the use of operational techniques that encourage good draft and complete combustion.

Inspect your chimney frequently and clean it whenever accumulation exceeds 1/4”.

Back-puffing

Back-puffing is a condition that results when the draft is too weak to pull flue gases out of the chimney system as fast as the fire generates them. Volatile gases build up within the firebox until reaching a density and temperature at which they ignite. With this ignition, you may hear a muffled popping sound and see a bit of smoke forced out of the stove.

This condition is most likely to occur in the Spring or Fall when moderate outdoor temperatures and low intensity fires produce weak draft. If your stove back-puffs, open the damper to let the smoke rise to the flue more quickly. Also, open the air inlets to induce a livelier fire and speed airflow through the stove. Avoid large loads of firewood at one time. You should always see lively, dancing flames in the firebox; a lazy, smoky fire is inefficient and will promote draft problems.

Draft Testing

An easy way to determine whether your chimney draft is strong enough is to close the stove damper, wait a few minutes to let the airflow stabilize, and then test whether you can vary the strength of the fire by swinging the air control open and closed. Results here are not instant; you may need to wait a few minutes for a change in the air control setting to have an effect on the fire. If there is no change, the draft is not yet strong enough to let you close the damper. You will need to open it for a while longer and manage the fire with the air inlet until the draft strengthens.

Keep a record of your operating habits and relate them to their effects on the stove’s function. You’ll be rewarded with safe and efficient performance.

Negative Pressure

Good draft also depends on a sufficient supply of air to the stove. The chimney can’t pull in more air than is available to it. Sluggish draft can be caused by a house that is tight enough to prevent the ready flow of air to the stove, or by competition between the stove and other appliances that vent indoor air to the outside; i.e., exhaust fans for range hoods, clothes dryers, bathroom fans, etc.

If the chimney draws well when all such equipment is turned off (or sealed, in the case of fireplaces and/or other stoves), you need to be attentive in timing the use of the other appliances. If you need to crack a nearby window or door to enable the chimney to pull well, you should install an outside-air intake to bring combustion air into the room.

Conclusion

Woodburning is more an art than a science. Art includes technique; and since installations, homes, and fuel vary, the stove operator must also vary technique, (mostly timing), to achieve satisfying results. Over time, you will become familiar with the features of your particular installation; you will be able to identify cause and effect in a variety of seasonal circumstances, and adapt your operating habits to changing conditions.

LIMITED LIFETIME Warranty

For Dutchwest Model 2478 Non-Catalytic Wood Stove

Limited Lifetime Warranty

Vermont Castings Group warrants that all refractory brick and material used in this product will be warranted against deterioration not resulting from physical damage or overloading of the woodstove for the lifetime of this product. This coverage includes the components of the EverBurn System: "shoe, fountain, and fireback. Coverage is provided only to the original purchaser.

Limited 3 Year Warranty

All cast iron parts are warranted for a period of three years against breakage, cracking or burn-through.

Limited 1 Year Warranty

The following parts of the woodburning stove are warranted to be free of defects in material and workmanship for a period of one year from the date you receive it: The handles, glass door panels, door gasketing and porcelain finish. Any of these items found to be defective will be repaired or replaced at no charge, upon the return of the part with postage prepaid to a Dutchwest Authorized Dealer.

Any parts repaired or replaced during the limited warranty period will be warranted under the terms of the limited warranty for a period not to exceed the remaining term of the original limited warranty or six (6) months, whichever is longer.

Exclusions & Limitations

1. This warranty is non-transferable.
2. This warranty does not cover misuse of the stove. Misuse includes overfiring, which will result if the stove is used in such a manner as to cause one or more of the plates to glow red. Overfiring can be identified later by warped plates and areas where the paint pigment has burned off. Overfiring in enamel stoves is identified by bubbling, cracking, chipping and discoloration of the porcelain enamel finish. Vermont Castings Group offers no warranty on chipping of enamel surfaces. Inspect your woodburning stove prior to accepting it for any damage to the enamel.
3. This warranty does not cover misuse of the stove as described in the Owners Guide, nor does it cover a stove which has been modified unless authorized by a Vermont Castings Group representative in writing. This warranty does not cover damage to the stove caused by burning salt saturated wood, chemically treated wood, or any fuel not recommended in the Owners Guide.
4. This warranty does not cover a stove repaired by someone other than a Dutchwest Authorized Dealer.
5. Damage to the unit while in transit is not covered by this warranty but is subject to a claim against the common carrier. Contact the Dutchwest Authorized Dealer from whom you purchased your stove or Vermont Castings Group if the purchase was direct. (Do not operate the stove as this may negate the ability to process the claim with the carrier).

6. Claims are not valid where the installation does not conform to local building and fire codes or, in their absence, to the recommendations in our Owners Guide.
7. The salt air environment of coastal areas, or a high-humidity environment, can be corrosive to the porcelain enamel finish. These conditions can cause rusting of the cast iron beneath the porcelain enamel finish, which will cause the porcelain enamel finish to flake off. This warranty does not cover damage caused by a salt air or high-humidity environment.
8. Vermont Castings Group shall have no obligation to enhance or update any unit once manufactured.

IN NO EVENT SHALL Vermont Castings Group BE LIABLE FOR INCIDENTAL AND CONSEQUENTIAL DAMAGES. ALL IMPLIED WARRANTIES, INCLUDING THE IMPLIED WARRANTIES OF MERCHANTABILITY AND FITNESS, ARE LIMITED TO THE DURATION OF THIS WRITTEN WARRANTY. THIS WARRANTY SUPERCEDES ALL OTHER ORAL OR WRITTEN WARRANTIES.

Some states do not allow the exclusion or limitations of incidental and consequential damages or limitations on how long an implied warranty lasts, so the above limitations may not apply to you. This warranty gives you specific rights and you may have other rights, which vary from state to state.

How to Obtain Service

If a defect is noted within the warranty period, the customer should contact a Dutchwest Authorized Dealer or Vermont Castings Group if the purchase was direct with the following information:

1. Name, address, and telephone number of the purchaser
2. Date of Purchase.
3. Serial number from the label on the back
4. Nature of the defect or damage.
5. Any relevant information or circumstances, e.g., installation, mode of operation when defect was noted.

A warranty claim will then start in process. Vermont Castings Group reserves the right to withhold final approval of a warranty claim pending a visual inspection of the defect by authorized representatives.