

This appliance has been retired.
For replacement parts, please refer to the individual
service parts list located on the brand websites.

Installation Manual

Installation and Appliance Setup

INSTALLER: Leave this manual with party responsible for use and operation.
OWNER: Retain this manual for future reference.

NOTICE: DO NOT discard this manual!

heatilator
The first name in fireplaces

Models:

CD4236IFTR

CD4236IFTLR

CD4842IFTR

CD4842IFTLR

GAS-FIRED

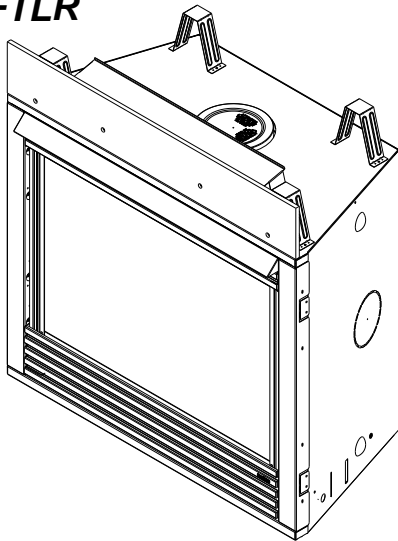

This appliance may be installed as an OEM installation in manufactured home (USA only) or mobile home and must be installed in accordance with the manufacturer's instructions and the *Manufactured Home Construction and Safety Standard, Title 24 CFR, Part 3280* in the United States, or the *Standard for Installation in Mobile Homes, CAN/CSA Z240 MH Series*, in Canada.

This appliance is only for use with the type(s) of gas indicated on the rating plate. This appliance is not convertible for use with other gases, unless a certified kit is used.

In the Commonwealth of Massachusetts installation must be performed by a licensed plumber or gas fitter.
See Table of Contents for location of additional Commonwealth of Massachusetts requirements.

⚠ WARNING:
FIRE OR EXPLOSION HAZARD
Failure to follow safety warnings exactly could result in serious injury, death, or property damage.

- **DO NOT** store or use gasoline or other flammable vapors and liquids in the vicinity of this or any other appliance.
- **What to do if you smell gas**
 - **DO NOT** try to light any appliance.
 - **DO NOT** touch any electrical switch. **DO NOT** use any phone in your building.
 - Leave the building immediately.
 - Immediately call your gas supplier from a neighbor's phone. Follow the gas supplier's instructions.
 - If you cannot reach your gas supplier, call the fire department.
- Installation and service must be performed by a qualified installer, service agency, or the gas supplier.

⚠ DANGER



HOT GLASS WILL CAUSE BURNS.

DO NOT TOUCH GLASS UNTIL COOLED.

NEVER ALLOW CHILDREN TO TOUCH GLASS.

A barrier designed to reduce the risk of burns from the hot viewing glass is provided with this appliance and must be installed for the protection of children and other at-risk individuals.

▲ Safety Alert Key:

- **DANGER!** Indicates a hazardous situation which, if not avoided will result in death or serious injury.
- **WARNING!** Indicates a hazardous situation which, if not avoided could result in death or serious injury.
- **CAUTION!** Indicates a hazardous situation which, if not avoided, could result in minor or moderate injury.
- **NOTICE:** Used to address practices not related to personal injury.

Note: The term “recommend” or “recommended” does not indicate a requirement. It is a best practice suggested by Hearth & Home Technologies®.

Table of Contents

Installation Standard Work Checklist	3
--	---

1 Product Specific and Important Safety Information

A. Appliance Certification	4
B. Glass Specifications	4
C. BTU Specifications	4
D. High Altitude Installations	4
E. Non-Combustible Materials Specification	4
F. Combustible Materials Specification	4
G. Electrical Codes	4
H. California	4
I. Requirements for the Commonwealth of Massachusetts	5

2 Getting Started

A. Design and Installation Considerations	6
B. Good Faith Wall Surface	6
C. Tools and Supplies Needed	6
D. Inspect Appliance and Components	7

3 Framing and Clearances

A. Appliance/Decorative Front Dimension Diagrams	8
B. Clearances to Combustibles	12
C. Constructing the Appliance Chase	14
D. Floor Protection	14

4 Termination Location and Vent Information

A. Vent Termination Minimum Clearances	15
B. Vent Terminal Clearances	16
C. Approved Pipe	17
D. Use of Elbows	18
E. Measuring Standards	19
F. Vent Diagrams	20

5 Vent Clearances and Framing

A. Pipe Clearances to Combustibles	33
B. Wall Penetration Framing/Firestops	33
C. Ceiling Firestop/Floor Penetration Framing	34
D. Install Attic Insulation Shield	34

6 Appliance Preparation

A. Vent Collar Preparation	35
B. Installing Optional Heat Management Systems	37
C. Securing and Leveling the Appliance	38
D. Installing the Non-combustible Board	38

7 Venting and Chimneys

A. Assemble Vent Sections	39
B. Assemble Vent Sections	40
C. Assemble Slip Sections	41
D. Secure the Vent Sections	42
E. Disassemble Vent Sections	42
F. Vertical Termination Requirements	43
G. Horizontal Termination Requirements	44

8 Electrical Information

A. General Information	46
B. Wiring Requirements	47

9 Gas Information

A. Fuel Conversion	49
B. Gas Pressure	49
C. Gas Connection	49
D. High Altitude Installations	49
E. Air Shutter Setting	50

10 Finishing

A. Facing Material	51
B. Mantel and Wall Projections	52
C. Facing Material	53
D. Decorative Fronts	53

11 Appliance Setup

A. Remove Fixed Glass Assembly	56
B. Remove the Shipping Materials	56
C. Clean the Appliance	56
D. Install the Refractory (Optional)	56
E. Ember Placement	57
F. Place the Lava Rock	57
G. Install the Log Assembly	58
H. IntelliFire Touch® Control System Setup	60
I. Install Fixed Glass Assembly	60
J. Fiber Refractory Color Review	60

12 Reference Materials

A. Vent Components Diagrams	61
B. Accessories	73

➔ = Contains updated information.

Installation Standard Work Checklist

ATTENTION INSTALLER: Follow this Standard Work Checklist

This standard work checklist is to be used by the installer in conjunction with, not instead of, the instructions contained in this installation manual.

Customer: _____ Lot/Address: _____ Model (circle one): CD4236IFTR CD4236IFTLR CD4842IFTR CD4842IFTLR	Date Installed: _____ Location of Fireplace: _____ Installer: _____ Dealer/Distributor Phone # _____ Serial #: _____
--	---

WARNING! Risk of Fire or Explosion! Failure to install appliance according to these instructions could lead to a fire or explosion.

<u>Appliance Install</u>	YES	IF NO, WHY?
Verified that the chase is insulated and sealed. (Pg. 14)	<input type="checkbox"/>	_____
Required non-combustible board is installed. (Pg. 38)	<input type="checkbox"/>	_____
Verified clearances to combustibles. (Pg. 12-13)	<input type="checkbox"/>	_____
Fireplace is leveled and secured. (Pg. 38)	<input type="checkbox"/>	_____
<u>Venting/Chimney Section 7 (Pg 39-45)</u>		
Venting configuration complies to vent diagrams.	<input type="checkbox"/>	_____
Venting installed, locked and secured in place with proper clearance.	<input type="checkbox"/>	_____
Elbow heat shield installed per requirements. (Pg 22, 33)	<input type="checkbox"/>	_____
Firestops installed.	<input type="checkbox"/>	_____
Attic insulation shield installed.	<input type="checkbox"/>	_____
Exterior wall/Roof flashing installed and sealed.	<input type="checkbox"/>	_____
Terminations installed and sealed.	<input type="checkbox"/>	_____
<u>Electrical Section 8 (Pg 46-48)</u>		
Unswitched power (110-120 VAC) provided to the appliance.	<input type="checkbox"/>	_____
Switch wires properly installed.	<input type="checkbox"/>	_____
<u>Gas Section 9 (Pg 49-50)</u>		
Proper appliance for fuel type.	<input type="checkbox"/>	_____
Was a conversion performed?	<input type="checkbox"/>	_____
Leak check performed and inlet pressure verified.	<input type="checkbox"/>	_____
Verified proper air shutter setting for installation type.	<input type="checkbox"/>	_____
<u>Finishing Section 10 (Pg 51-55)</u>		
Combustible materials not installed in non-combustible areas.	<input type="checkbox"/>	_____
Verified all clearances meet installation manual requirements.	<input type="checkbox"/>	_____
Mantels and wall projections comply with installation manual requirements.	<input type="checkbox"/>	_____
<u>Appliance Setup Section 11 (Pg 56-60)</u>		
All packaging and protective materials removed (inside & outside of appliance).	<input type="checkbox"/>	_____
Refractories, logs, lava rock, and embers installed correctly.	<input type="checkbox"/>	_____
Glass assembly installed and secured.	<input type="checkbox"/>	_____
Accessories installed properly.	<input type="checkbox"/>	_____
Decorative front properly installed.	<input type="checkbox"/>	_____
Manual bag and all of its contents are removed from inside/under the appliance and given to party responsible for use and operation.	<input type="checkbox"/>	_____
Started appliance and verified no gas leaks exist.	<input type="checkbox"/>	_____

- Hearth & Home Technologies recommends the following:**
- Photographing the installation and copying this checklist for your file.
 - That this checklist remain visible at all times on the appliance until the installation is complete.

Comments: Further description of the issues, who is responsible (Installer/ Builder/ Other Trades, etc) and corrective action needed _____

Comments Communicated to party responsible _____ by _____ on _____
(Builder / Gen. Contractor/) (Installer) (Date)

→ = Contains updated information. 2511-982 11/17

1 Product Specific and Important Safety Information

A. Appliance Certification

MODELS: CD4236IFTR CD4236IFTLR
CD4842IFTR CD4842IFTLR
LABORATORY: Underwriters Laboratories, Inc. (UL)
TYPE: Direct Vent Heater
STANDARD: CSA / ANSI Z21.88:19 • CSA 2.33:19

This product is listed to ANSI standards for “Vented Gas Fireplace Heaters” and applicable sections of “Gas Burning Heating Appliances for Manufactured Homes and Recreational Vehicles”, and “Gas Fired Appliances for Use at High Altitudes”.

NOTICE: This installation must conform with local codes. In the absence of local codes you must comply with the National Fuel Gas Code, ANSI Z223.1-latest edition in the U.S.A. and the CAN/CGA B149 Installation Codes in Canada.

NOT INTENDED FOR USE AS A PRIMARY HEAT SOURCE.
This appliance is tested and approved as either supplemental room heat or as a decorative appliance. It should not be factored as primary heat in residential heating calculations.

B. Glass Specifications

Hearth & Home Technologies appliances manufactured with tempered glass may be installed in hazardous locations such as bathtub enclosures as defined by the Consumer Product Safety Commission (CPSC). The tempered glass has been tested and certified to the requirements of **ANSI Z97.1** and **CPSC 16 CFR 1202** (Safety Glazing Certification Council **SGCC# 1595** and **1597**. Architectural Testing, Inc. Reports **02-31919.01** and **02-31917.01**).

This statement is in compliance with **CPSC 16 CFR Section 1201.5** “Certification and labeling requirements” which refers to **15 U.S. Code (USC) 2063** stating “...Such certificate shall accompany the product or shall otherwise be furnished to any distributor or retailer to whom the product is delivered.”

Some local building codes require the use of tempered glass with permanent marking in such locations. Glass meeting this requirement is available from the factory. Please contact your dealer or distributor to order.

C. BTU Specifications

Models U.S. or Canada		Maximum Input BTU/h	Minimum Input BTU/h	Orifice Size (DMS)
CD4236IFTR (NG)	(0-2000 FT)	30,000	16,000	37
CD4236IFTLR (Propane)	(0-2000 FT)	29,000	16,000	52
CD4842IFTR (NG)	(0-2000 FT)	35,000	18,000	33
CD4842IFTLR (Propane)	(0-2000 FT)	32,500	17,000	51

D. High Altitude Installations

NOTICE: If the heating value of the gas has been reduced, these rules do not apply. Check with your local gas utility or authorities having jurisdiction.

When installing above 2000 feet elevation:

- In the USA: Reduce input rate 4% for each 1000 feet above 2000 feet.
- In CANADA: Input ratings are certified without a reduction of input rate for elevations up to 4500 feet (1370 m) above sea level. Please consult provincial and/or local authorities having jurisdiction for installations at elevations above 4500 feet (1370 m).

Check with your local gas utility to determine proper orifice size.

E. Non-Combustible Materials Specification

Material which will not ignite and burn. Such materials are those consisting entirely of steel, iron, brick, tile, concrete, slate, glass or plasters, or any combination thereof.

Materials that are reported as passing **ASTM E 136, Standard Test Method for Behavior of Materials in a Vertical Tube Furnace at 750 °C** shall be considered non-combustible materials.

F. Combustible Materials Specification

Materials made of or surfaced with wood, compressed paper, plant fibers, plastics, or other material that can ignite and burn, whether flame proofed or not, or plastered or unplastered shall be considered combustible materials.

G. Electrical Codes

NOTICE: This appliance must be electrically wired and grounded in accordance with local codes or, in the absence of local codes, with **National Electric Code ANSI/NFPA 70-latest edition** or the **Canadian Electric Code CSA C22.1**.

- A 110-120 VAC circuit for this product must be protected with ground-fault circuit-interrupter protection, in compliance with the applicable electrical codes, when it is installed in locations such as in bathrooms or near sinks.

H. California

WARNING: This product and the fuels used to operate this product (liquid propane or natural gas), and the products of combustion of such fuels, can expose you to chemicals including benzene, which is known to the State of California to cause cancer and reproductive harm. For more information go to: www.P65Warnings.ca.gov.

Note: The following requirements reference various Massachusetts and national codes not contained in this document.

I. Requirements for the Commonwealth of Massachusetts

For all side wall horizontally vented gas fueled equipment installed in every dwelling, building or structure used in whole or in part for residential purposes, including those owned or operated by the Commonwealth and where the side wall exhaust vent termination is less than seven (7) feet above finished grade in the area of the venting, including but not limited to decks and porches, the following requirements shall be satisfied:

Installation of Carbon Monoxide Detectors

At the time of installation of the side wall horizontal vented gas fueled equipment, the installing plumber or gas fitter shall observe that a hard wired carbon monoxide detector with an alarm and battery back-up is installed on the floor level where the gas equipment is to be installed. In addition, the installing plumber or gas fitter shall observe that a battery operated or hard wired carbon monoxide detector with an alarm is installed on each additional level of the dwelling, building or structure served by the side wall horizontal vented gas fueled equipment. It shall be the responsibility of the property owner to secure the services of qualified licensed professionals for the installation of hard wired carbon monoxide detectors.

In the event that the side wall horizontally vented gas fueled equipment is installed in a crawl space or an attic, the hard wired carbon monoxide detector with alarm and battery back-up may be installed on the next adjacent floor level.

In the event that the requirements of this subdivision can not be met at the time of completion of installation, the owner shall have a period of thirty (30) days to comply with the above requirements; provided, however, that during said thirty (30) day period, a battery operated carbon monoxide detector with an alarm shall be installed.

Approved Carbon Monoxide Detectors

Each carbon monoxide detector as required in accordance with the above provisions shall comply with NFPA 720 and be ANSI/UL 2034 listed and IAS certified.

Signage

A metal or plastic identification plate shall be permanently mounted to the exterior of the building at a minimum height of eight (8) feet above grade directly in line with the exhaust vent terminal for the horizontally vented gas fueled heating appliance or equipment. The sign shall read, in print size no less than one-half (1/2) in. in size, "**GAS VENT DIRECTLY BELOW. KEEP CLEAR OF ALL OBSTRUCTIONS**".

Inspection

The state or local gas inspector of the side wall horizontally vented gas fueled equipment shall not approve the installation unless, upon inspection, the inspector observes carbon monoxide detectors and signage installed in accordance with the provisions of 248 CMR 5.08(2)(a)1 through 4.

Exemptions

The following equipment is exempt from 248 CMR 5.08(2)(a)1 through 4:

- The equipment listed in Chapter 10 entitled "Equipment Not Required To Be Vented" in the most current edition of NFPA 54 as adopted by the Board; and
- Product Approved side wall horizontally vented gas fueled equipment installed in a room or structure separate from the dwelling, building or structure used in whole or in part for residential purposes.

MANUFACTURER REQUIREMENTS

Gas Equipment Venting System Provided

When the manufacturer of Product Approved side wall horizontally vented gas equipment provides a venting system design or venting system components with the equipment, the instructions provided by the manufacturer for installation of the equipment and the venting system shall include:

- Detailed instructions for the installation of the venting system design or the venting system components; and
- A complete parts list for the venting system design or venting system.

Gas Equipment Venting System NOT Provided

When the manufacturer of a Product Approved side wall horizontally vented gas fueled equipment does not provide the parts for venting the flue gases, but identifies "special venting systems", the following requirements shall be satisfied by the manufacturer:

- The referenced "special venting system" instructions shall be included with the appliance or equipment installation instructions; and
- The "special venting systems" shall be Product Approved by the Board, and the instructions for that system shall include a parts list and detailed installation instructions.

A copy of all installation instructions for all Product Approved side wall horizontally vented gas fueled equipment, all venting instructions, all parts lists for venting instructions, and/or all venting design instructions shall remain with the appliance or equipment at the completion of the installation.

See Gas Connection section for additional Commonwealth of Massachusetts requirements.

2 Getting Started

A. Design and Installation Considerations

Heatilator direct vent gas appliances are designed to operate with all combustion air siphoned from outside of the building and all exhaust gases expelled to the outside. No additional outside air source is required.

Installation **MUST** comply with local, regional, state and national codes and regulations. Consult insurance carrier, local building inspector, fire officials or authorities having jurisdiction over restrictions, installation inspection and permits.

Before installing, determine the following:

- Where the appliance is to be installed.
- The vent system configuration to be used.
- Gas supply piping requirements.
- Provisions for optional heat management system.
- Electrical wiring requirements.
- Framing and finishing details.
- Whether optional accessories—devices such as a fan, wall switch, or remote control—are desired.

Installation and service of this appliance should be performed by qualified personnel. Hearth & Home Technologies recommends HHT Factory Trained or NFI certified professionals.



Improper installation, adjustment, alteration, service or maintenance can cause injury or property damage. For assistance or additional information, consult a qualified service technician, service agency or your dealer.

B. Good Faith Wall Surface

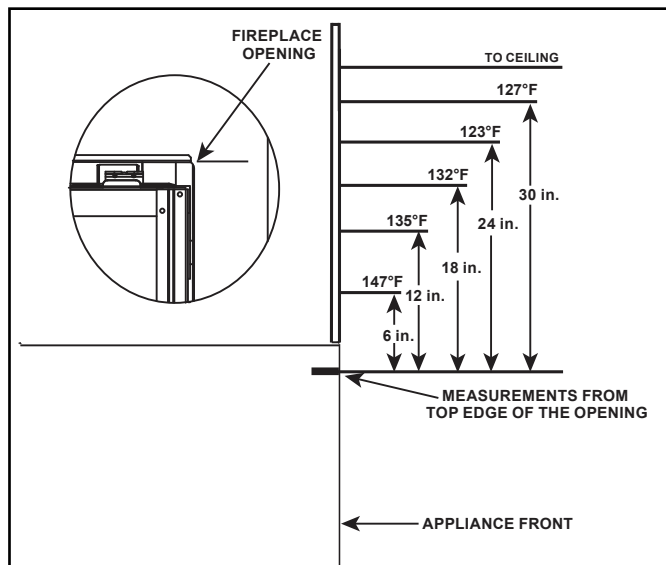

Figure 2.1 Good Faith Wall Surface Temperatures Above Appliance

If installing a television (TV) above the appliance, see Section 3 of the appliance Owner's Manual.

NOTICE: *Temperatures listed above are taken with a temperature measuring probe as prescribed by the test standard used for appliance certification. Temperatures on walls or mantels taken with an infrared thermometer may yield increased temperatures of up to 30 degrees or more depending on the thermometer settings and material characteristics being measured. Use appropriate finishing materials that are able to withstand these conditions. For additional finishing guidelines, see Section 10.*

C. Tools and Supplies Needed

Before beginning the installation be sure that the following tools and building supplies are available.

- | | |
|---|-----------------------------------|
| Tape measure | Framing material |
| Pliers | Hammer |
| Phillips screwdriver | Manometer |
| Gloves | Framing square |
| Voltmeter | Electric drill and bits (1/4 in.) |
| Plumb line | Safety glasses |
| Level | Reciprocating saw |
| Flat blade screwdriver | |
| Non-corrosive leak check solution | |
| 1/2 - 3/4 in. length, #6 or #8 Self-drilling screws | |
| Caulking material (300 °F minimum continuous exposure rating) | |
| One 1/4 in. female connection (for optional fan) | |

D. Inspect Appliance and Components

- Carefully remove the appliance and components from the packaging.
- The vent system components and decorative doors and fronts may be shipped in separate packages.
- If packaged separately, the log set and appliance grate must be installed.
- Report to your dealer any parts damaged in shipment, particularly the condition of the glass.
- **Read all of the instructions before starting the installation. Follow these instructions carefully during the installation to ensure maximum safety and benefit.**

WARNING! Risk of Fire or Explosion! Damaged parts could impair safe operation. **DO NOT** install damaged, incomplete or substitute components. Keep appliance dry.

Hearth & Home Technologies disclaims any responsibility for, and the warranty will be voided by, the following actions:

- Installation and use of any damaged appliance or vent system component.
- Modification of the appliance or vent system.
- Installation other than as instructed by Hearth & Home Technologies.
- Improper positioning of the gas logs or the glass assembly.
- Installation and/or use of any component part not approved by Hearth & Home Technologies.

Any such action may cause a fire hazard.

WARNING! Risk of Fire, Explosion or Electric Shock! **DO NOT** use this appliance if any part has been under water. Call a qualified service technician to inspect the appliance and to replace any part of the control system and/or gas control which has been under water.

3 Framing and Clearances

A. Appliance/Decorative Front Dimension Diagrams

Dimensions are actual appliance dimensions. Use for reference only. For framing dimensions and clearances refer to Section 5.

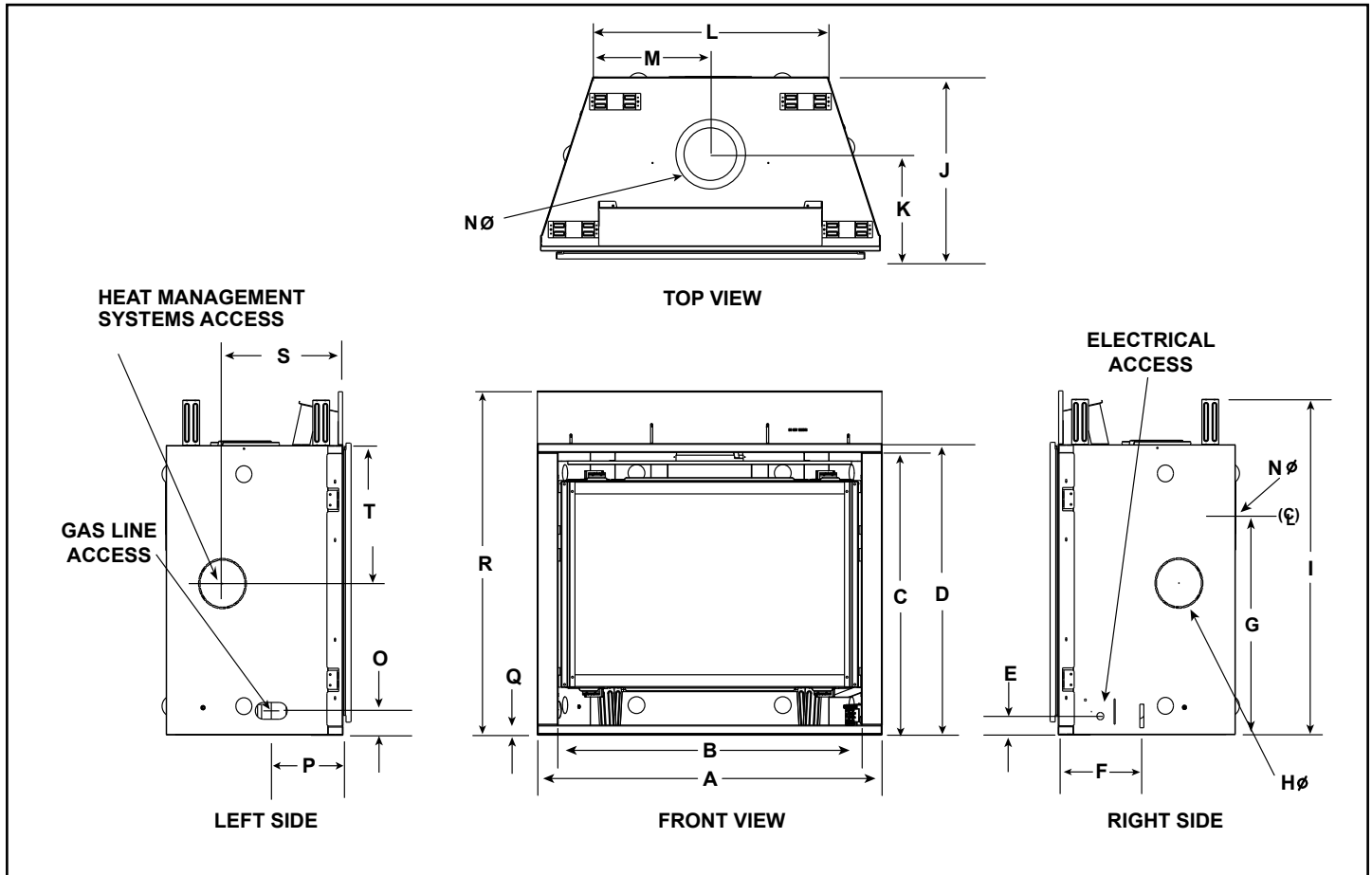

Appliance Dimensions Table

Location	Inches	Millimeters
A	41	1041
B	36-1/8	918
C	33-1/2	851
D	34-5/8	879
E	2-1/4	57
F	9-11/16	246
G	26-7/8	683
H	6 dia	152
I	39-7/8	1013
J	21	533

Location	Inches	Millimeters
K	11-11/16	297
L	28-1/2	724
M	14-1/4	362
N	8-1/2	216
O	2-7/8	73
P	8-1/2	216
Q	1	25
R	40-7/8	1038
S	14-3/16	360
T	15-3/8	391

Figure 3.1 Appliance Dimensions - CD4236IFTLR, CD4236IFTR

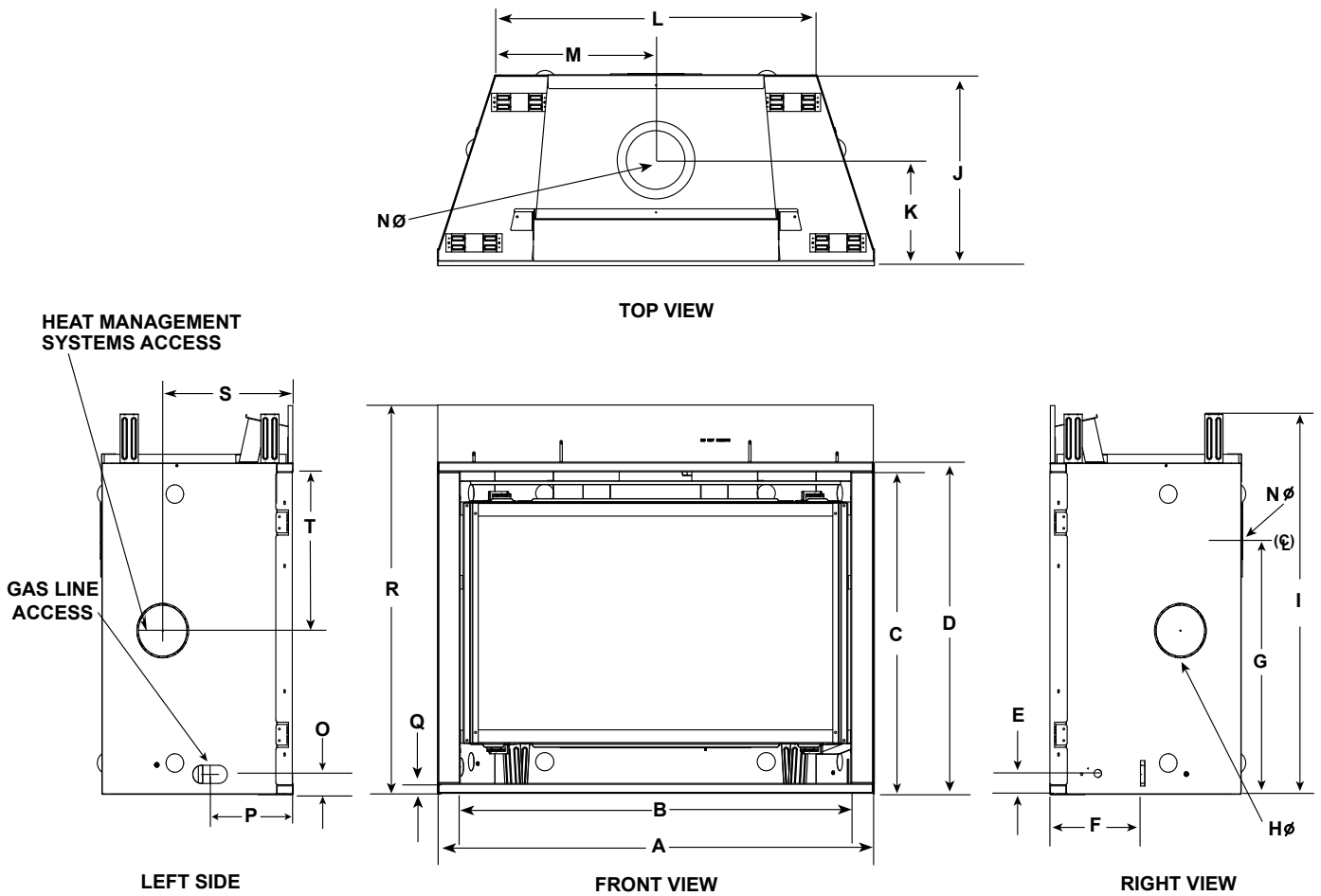

Appliance Dimensions Table

Location	Inches	Millimeters
A	48	1219
B	43-1/8	1096
C	35-1/2	902
D	36-5/8	930
E	2-3/8	60
F	9-15/16	252
G	28-7/8	734
H	6	152
I	41-7/8	1064
J	21	866

Location	Inches	Millimeters
K	11-11/16	297
L	35-1/2	901
M	17-3/4	451
N	8-1/2	216
O	2-7/8	73
P	8-1/2	216
Q	1	25
R	42-7/8	1089
S	14-3/16	360
T	17-1/16	433

Figure 3.2 Appliance Dimensions - CD4842IFTLR, CD4842IFTR

SIMON DECORATIVE FRONTS

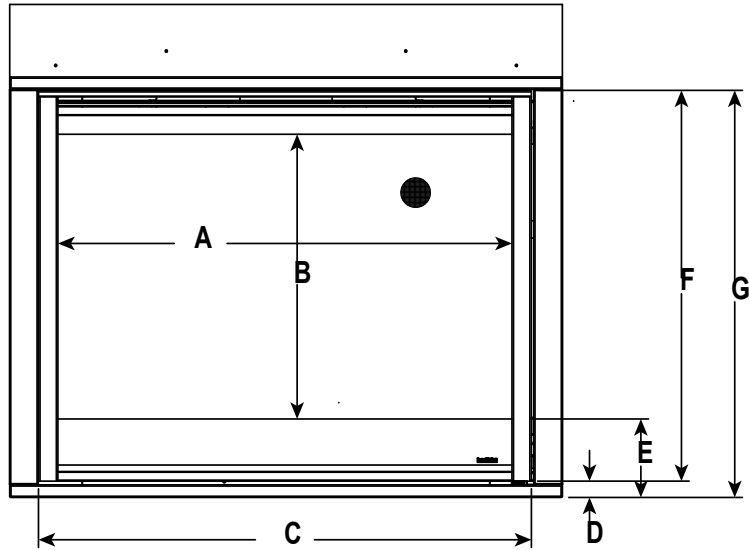

			A	B	C	D	E	F	G
SIM-36C	CD4236IFTR CD4236IFTLR	in.	32-7/16	22-1/16	35-13/16	1-7/16	7-1/16	32-1/16	33-1/2
		mm	824	560	910	37	179	814	851
SIM-42C	CD4842IFTR CD4842IFTLR	in.	39-7/16	24	42-13/16	1-7/16	7-1/16	33-15/16	35-3/8
		mm	1002	610	1087	37	179	862	899

CRAFTSMAN DECORATIVE FRONTS

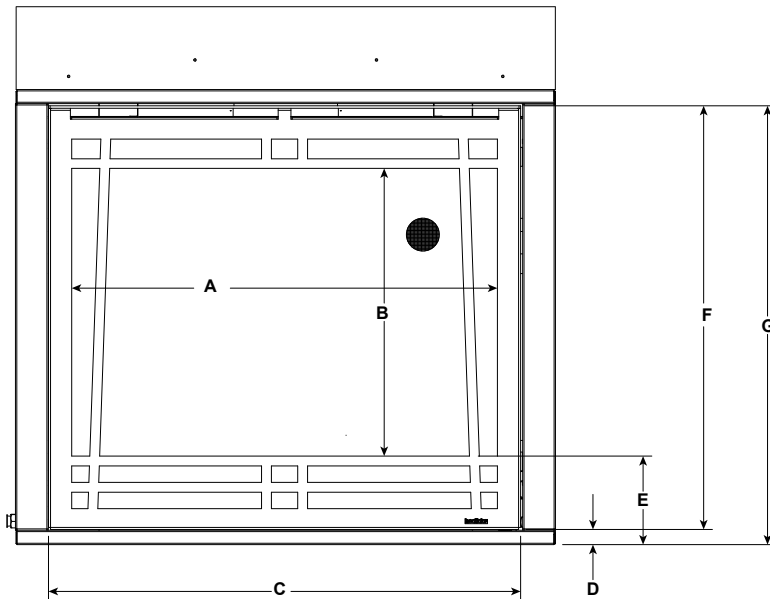

			A	B	C	D	E	F	G
CRAFT-36C	CD4236IFTR CD4236IFTLR	in.	32-3/8	21-7/8	35-15/16	1-1/4	6-3/4	32-1/4	33-1/2
		mm	822	556	913	32	172	819	851
CRAFT-42C	CD4842IFTR CD4842IFTLR	in.	39-5/16	23-13/16	42-13/16	1-1/4	6-3/4	34-1/8	35-3/8
		mm	999	605	1087	32	172	867	899

Figure 3.3 Decorative Front dimensions - Simon and Craftsman

CONTOUR DECORATIVE FRONTS

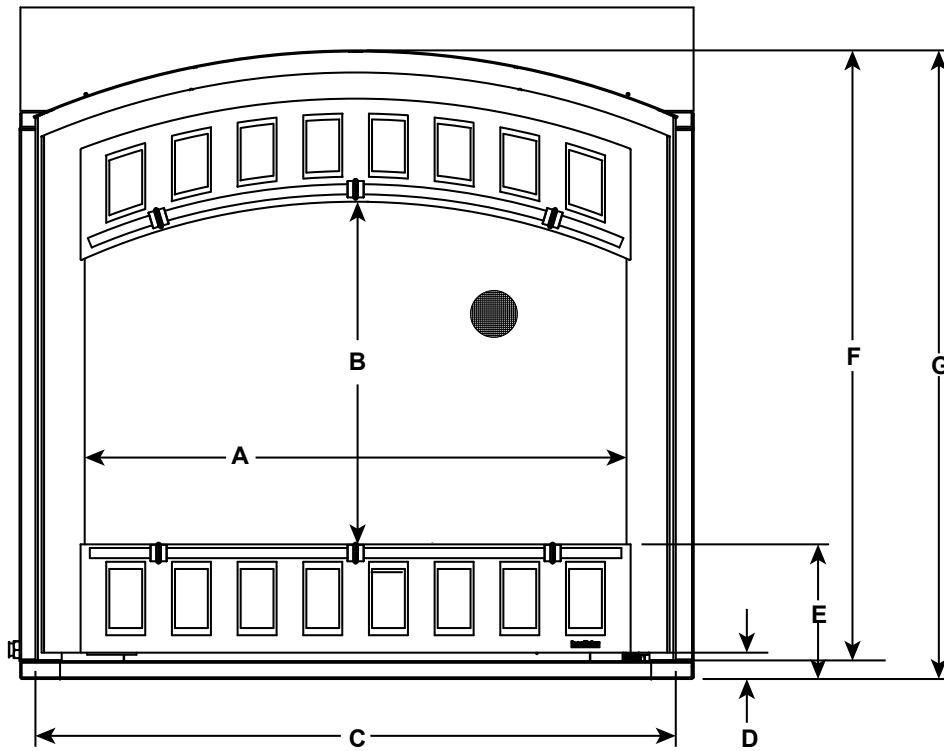

			A	B	C	D	E	F	G
CON-36C	CD4236IFTR CD4236IFTLR	in.	33	20-7/8	39	1-3/8	8	37-1/4	38-1/4
		mm	838	530	991	35	203	946	972
CON-42C	CD4842IFTR CD4842IFTLR	in.	40	22-3/4	46	1-3/8	8	39	40
		mm	1016	578	1168	35	203	991	1016

Figure 3.4 Decorative Front Dimensions - Contour

B. Clearances to Combustibles

When selecting a location for the appliance it is important to consider the required clearances to walls. See Figure 3.5.

WARNING! Risk of Fire or Burns! Provide adequate clearance around air openings and for service access. Due to high temperatures, the appliance should be located out of traffic and away from furniture and draperies.

NOTICE: Illustrations reflect typical installations and are FOR DESIGN PURPOSES ONLY. Illustrations/diagrams are not drawn to scale. Actual installation may vary due to individual design preference.

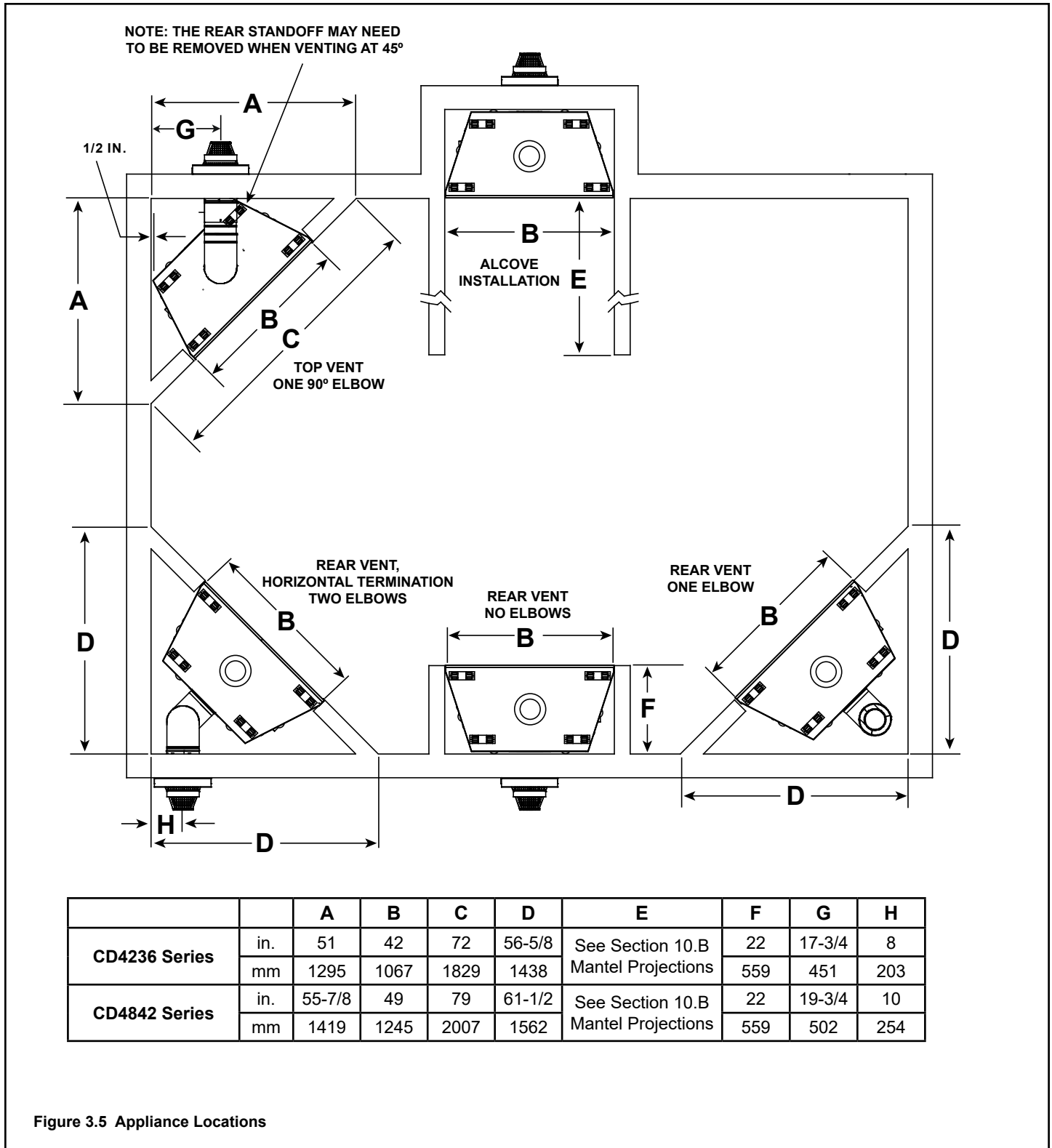

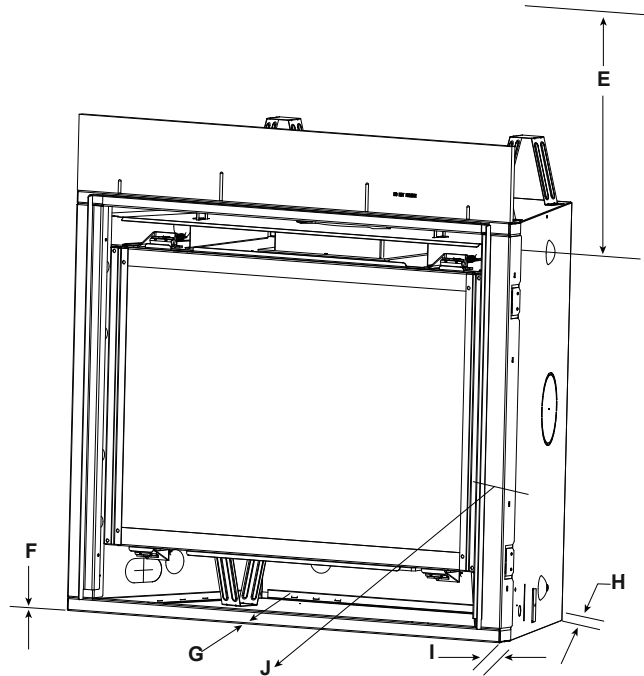
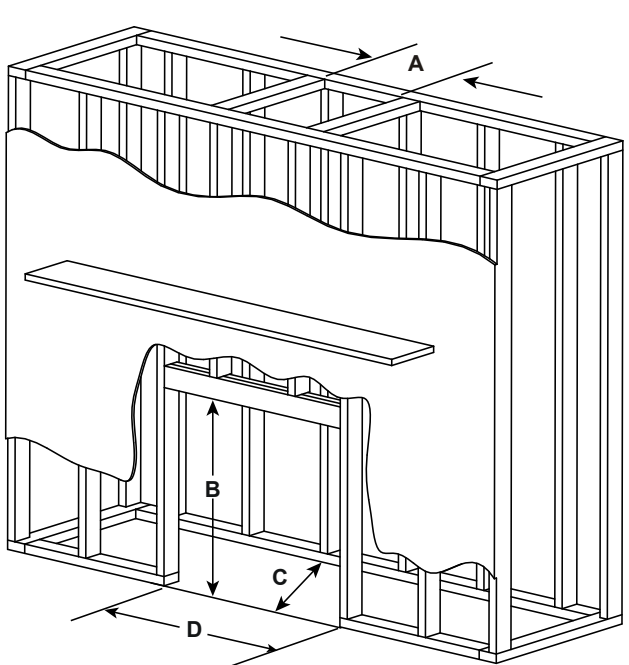
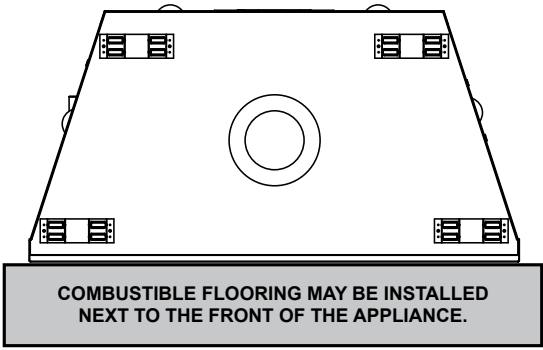

* MINIMUM FRAMING DIMENSIONS											
Models		A	B	C**	D	E	F	G***	H	I	J
		Rough Opening (Width)	Rough Opening (Height)	Rough Opening (Depth)	Rough Opening (Width)	Clearance to Ceiling	Combustible Floor	Combustible Flooring	Behind Appliance	Sides of Appliance	Front of Appliance
CD4236 Series	in.	10	40-1/8	22	42	32	0	0	1/2	1/2	36
	mm	254	1019	559	1067	813	0	0	13	13	914
CD4842 Series	in.	10	42-1/8	22	49	32	0	0	1/2	1/2	36
	mm	254	1070	559	1245	813	0	0	13	13	914

* Adjust framing dimensions for interior sheathing (such as sheetrock)
 C** Add 12 inches for rear venting with one 90° elbow.
 G*** For installations with vinyl flooring, see Section 3.D.

Figure 3.6 Clearances to Combustibles

C. Constructing the Appliance Chase

A chase is a vertical box-like structure built to enclose the gas appliance and/or its vent system. In cooler climates the vent should be enclosed inside the chase.

NOTICE: Treatment of ceiling firestops and wall shield firestops and construction of the chase may vary with the type of building. These instructions are not substitutes for the requirements of local building codes. Therefore, you **MUST** check local building codes to determine the requirements to these steps.

NOTICE: Where required by code, install only sprinkler heads with a sprinkler activation temperature classified as **Extra High**.

- *Sprinklers inside of chase: Keep sprinkler head away from vent and chimney.*
- *Heat Management applications: Maintain 36 inches of clearance to openings from which heat is discharged such as heat zone registers, etc. Refer to Section 6.B for Heat Management options allowed for this appliance.*

Chases should be constructed and insulated in the same manner as the thermal envelope of the home based on the code requirements for that climate zone to prevent air leakage and draft problems. The chase is an extension of the building thermal envelope.

To further prevent drafts and air leakage, the wall shield and ceiling firestops should be caulked with caulk with a minimum of 300 °F continuous exposure rating to seal gaps. Gas line holes and other openings should be caulked with caulk with a minimum of 300 °F continuous exposure rating or stuffed with unfaced insulation. If the appliance is being installed on a cement surface, a layer of plywood may be placed underneath to prevent conducting cold up into the room.

NOTICE: Install appliance on hard metal or wood surfaces extending full width and depth. **DO NOT** install directly on carpeting, vinyl, tile or any combustible material other than wood.

WARNING! Risk of Fire! Maintain specified air space clearances to appliance and vent pipe:

- Insulation and other materials must be secured to prevent accidental contact.
- The chase must be properly blocked to prevent blown insulation or other combustibles from entering and making contact with fireplace or chimney.
- Failure to maintain airspace may cause overheating and a fire.

NOTICE: Where required by code, install only sprinkler heads with a sprinkler activation temperature classified as **Extra High**.

- *Sprinklers inside of chase: Keep sprinkler head away from vent and chimney.*
- *Heat Management applications: Maintain 36 inches of clearance to openings from which heat is discharged such as convection slots, passive heat registers, heat zone registers, etc. Refer to Section 6.B for Heat Management options allowed for this appliance.*

D. Floor Protection

Vinyl Flooring

Vinyl flooring is sensitive to heat. Hearth and Home Technologies does not recommend adhesive based vinyl flooring due to thermal expansion. Floating-style flooring can be used, but will reach temperatures up to 110 °F in a room with ambient temperature of 70 °F. Consult flooring specifications to ensure compatibility.

4 Termination Location and Vent Information

A. Vent Termination Minimum Clearances

⚠ WARNING

Fire Risk.
Maintain vent clearance to combustibles as specified.

- **DO NOT** pack air space with insulation or other materials.

Failure to keep insulation or other materials away from vent pipe could cause overheating and fire.

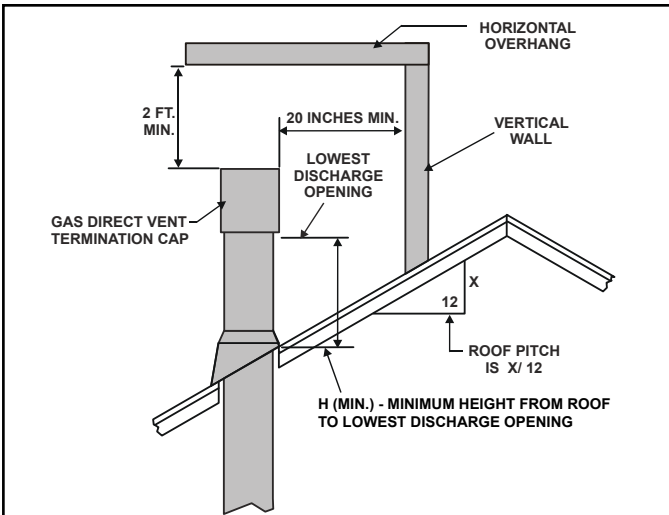

Roof Pitch	H (Min.) Ft.
Flat to 6/12.....	1.0*
Over 6/12 to 7/12.....	1.25*
Over 7/12 to 8/12.....	1.5*
Over 8/12 to 9/12.....	2.0*
Over 9/12 to 10/12.....	2.5*
Over 10/12 to 11/12.....	3.25
Over 11/12 to 12/12.....	4.0
Over 12/12 to 14/12.....	5.0
Over 14/12 to 16/12.....	6.0
Over 16/12 to 18/12.....	7.0
Over 18/12 to 20/12.....	7.5
Over 20/12 to 21/12.....	8.0

* H minimum may vary depending on regional snowfall. Refer to local codes.

Figure 4.1 Minimum Height From Roof to Lowest Discharge Opening

A	B
6 in. (minimum) up to 20 in. 152 mm/508 mm	18 in. minimum 457 mm
20 in. and over	0 in. minimum

- * If using decorative cap cover(s), this distance may need to be increased. Refer to the installation instructions supplied with the decorative cap cover.
- ** In a staggered installation with both gas and wood or fuel oil terminations, the wood or fuel oil termination cap must be higher than the gas termination cap.

Figure 4.2 Staggered Termination Caps

CAUTION! Risk of Burns! Termination caps are HOT, consider proximity to doors, traffic areas or where people may pass or gather (sidewalk, deck, patio, etc.). Listed cap shields available. Contact your dealer.

- Local codes or regulations may require different clearances.
- Hearth & Home Technologies assumes no responsibility for the improper performance of the appliance when the venting system does not meet these requirements.
- Vinyl protection kits are suggested for use with vinyl siding.
- Measure horizontal and vertical termination cap clearances as noted in Figure 4.3.

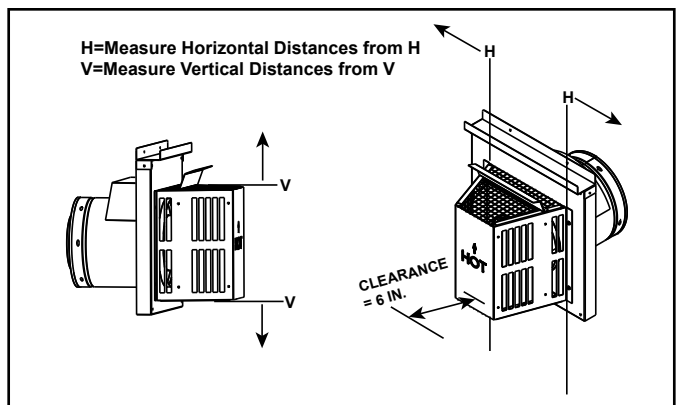
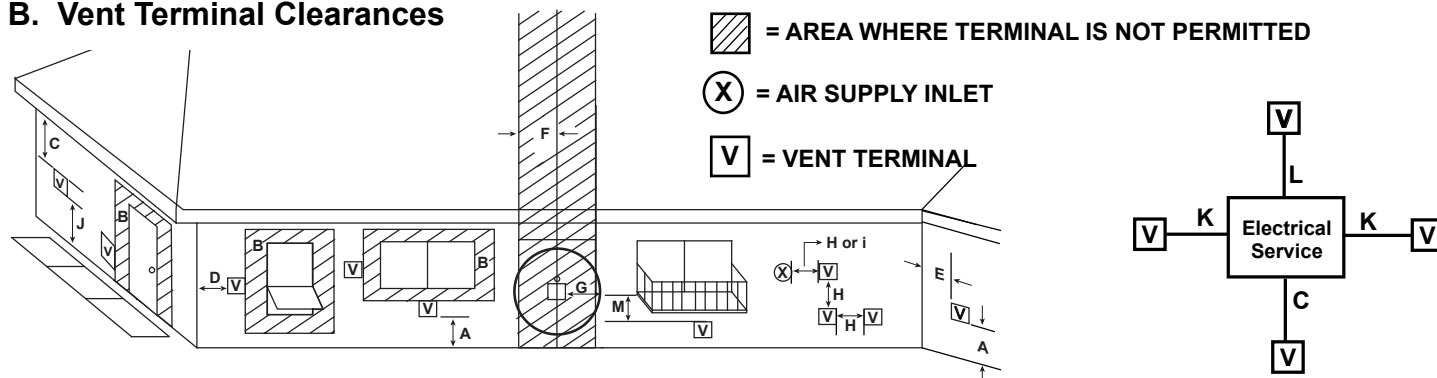

Figure 4.3

B. Vent Terminal Clearances



U.S.A. Installations: In accordance with the current ANSI Z223.1/NFPA 54, National Fuel Gas Code.

Canadian Installations: In accordance with the current CSA B149.1, Natural Gas and Propane Installation Code.

		U.S.A.	CANADA
A	Clearance above grade, veranda, porch, deck, or balcony	12 in. (305 mm)	12 in. (305 mm)
B	Clearance to window or door that may be opened, or to permanently closed window U.S.A.: = 9 in. min. (229 mm min.) CANADA: = 12 in. min. (305 mm min.)		
C	clearance below unventilated soffit	18 in. (457 mm)	18 in. (457 mm)
	clearance below ventilated soffit	18 in. (457 mm)	18 in. (457 mm)
	clearance below any vinyl soffits and electrical service	30 in. (762 mm)	30 in. (762 mm)
D	clearance to outside corner	6 in. (152 mm)	6 in. (152 mm)
E	clearance to inside corner	6 in. (152 mm)	6 in. (152 mm)
F	not to be installed above a gas meter/regulator assembly within 3 feet horizontally from the center-line of the regulator	3 ft (914 mm)	3 ft (914 mm)
G	clearance to gas service regulator vent outlet	3 ft (914 mm)	3 ft (914 mm)
H	clearance to non-mechanical air supply inlet to building or the combustion air inlet to any other appliance termination (mechanical or non-mechanical)	9 in. min. (229 mm min.)	12 in. min. (305 mm min.)
I	clearance to a mechanical (powered) air supply inlet *** (All mechanical air intakes within 10 feet of a horizontal termination cap must be a minimum of 3 feet below termination.)	3 ft (914 mm)***	6 ft (1.8 m)
J	On public property: clearance above paved sidewalk or a paved driveway.	7 ft (2.1 m)	7 ft (2.1 m)**
	**(A vent shall not terminate directly above a sidewalk or paved driveway which is located between two single family dwellings and serves both dwellings.)		
K	clearance from sides of electrical service	6 in. (152 mm)	6 in. (152 mm)
	Location of the vent termination must not interfere with access to the electrical service.		
L	clearance above electrical service	12 in. (305 mm)	12 in. (305 mm)
	Location of the vent termination must not interfere with access to the electrical service.		
M	clearance under veranda, porch, deck, balcony or overhang (Permitted only if veranda, porch, deck, or balcony is fully open on a minimum of two sides beneath the floor.)	18 in. (457 mm)	12 in. (305 mm)*
	vinyl or composite overhang	42 in. (1067 mm)	42 in. (1067 mm)

Figure 4.4 Minimum Clearances for Termination

C. Approved Pipe

This appliance is approved for use with Hearth & Home Technologies DVP or SLP venting systems. Refer to Section 12.A for vent component information and dimensions. Only use listed decorative termination caps/shrouds with Hearth & Home Technologies approved venting systems.

DO NOT mix pipe, fittings or joining methods from different manufacturers.

The pipe is tested to be run inside an enclosed wall. There is no requirement for inspection openings at each joint within the wall.

WARNING! Risk of Fire or Asphyxiation. *This appliance requires a separate vent. DO NOT vent to a pipe serving a separate solid fuel burning appliance.*

D. Use of Elbows

Diagonal runs have both vertical and horizontal vent aspects when calculating the effects. Use the rise for the vertical aspect and the run for the horizontal aspect. See Figure 4.5.

Two 45° elbows may be used in place of one 90° elbow. On 45° runs, one foot of diagonal is equal to 8-1/2 in. (216 mm) horizontal run and 8-1/2 in. (216 mm) vertical run. A length of straight pipe is allowed between two 45° elbows. See Figure 4.5.

Figure 4.6 shows the vertical and horizontal offsets for DVP or SLP elbows.

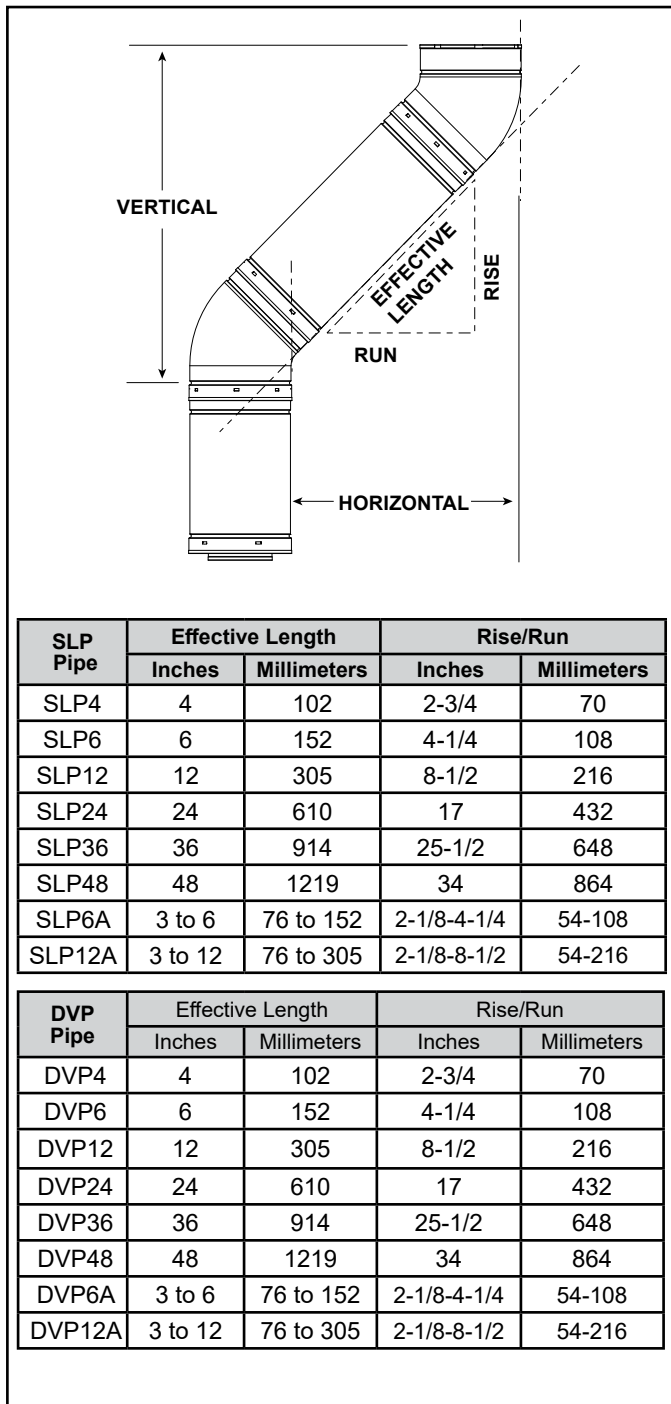

Figure 4.5

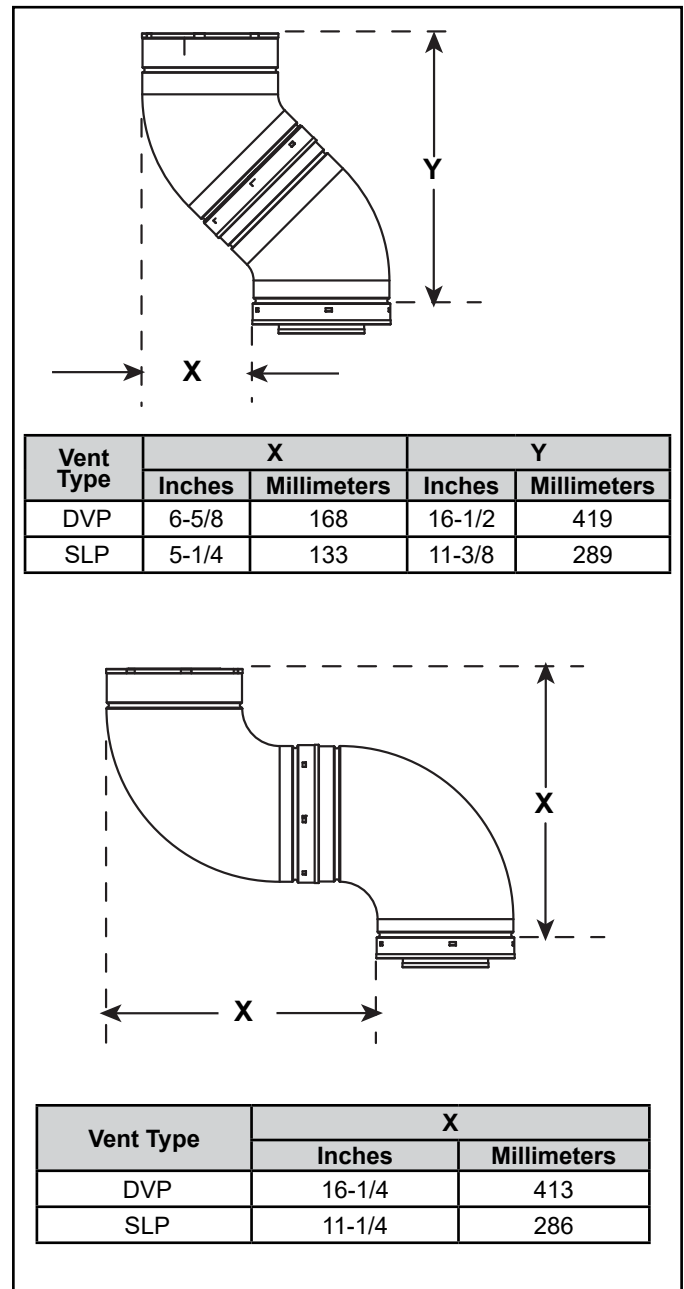

Figure 4.6 Vertical and Horizontal Offset for DVP and SLP Elbows

E. Measuring Standards

Vertical and horizontal measurements listed in the vent diagrams were made using the following standards:

- Pipe measurements are shown using the effective length of pipe. See Section 12.A (Figure 12.1 for DVP, Figure 12.8 for SLP) for information on effective length of pipe components.
- Horizontal terminations are measured to the outside mounting surface (flange of termination cap). See Figure 4.7.
- Vertical terminations are measured to top of last section of pipe. See Figure 4.8.
- Horizontal pipe installed level with no rise.

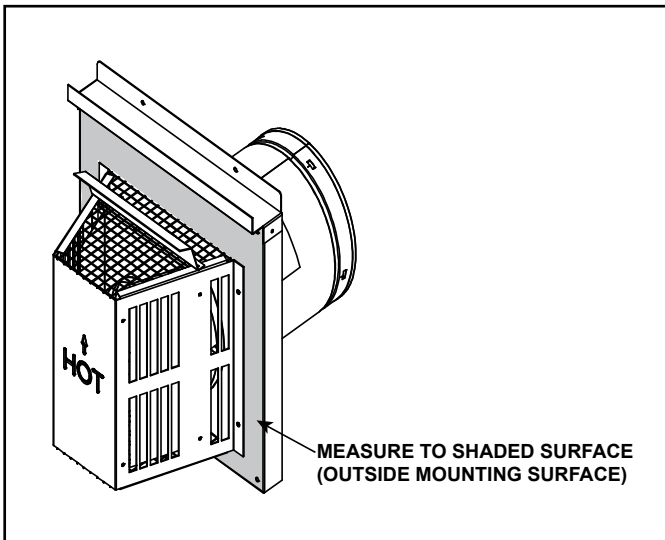

Figure 4.7 Measure to Outside Mounting Surface

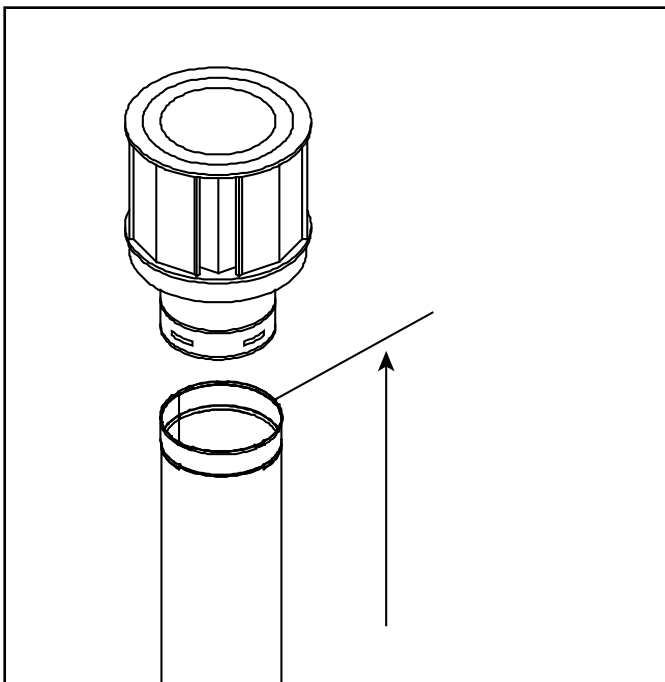

Figure 4.8 Measure to Top of Last Section of Pipe

F. Vent Diagrams

General Rules:

- SUBTRACT 3 ft. from the total H measurement for each 90° elbow installed horizontally.
- SUBTRACT 1-1/2 ft. from the total H measurement for each 45° elbow installed horizontally.
- A maximum of three 90° elbows (or six 45° elbows) may be used in any vent configuration. Some elbows may be installed horizontally. For example, see Figure 4.19.
- Elbows may be placed back to back anywhere in the system.
- Any 90° elbow may be replaced with two back to back 45° elbows.
- When penetrating a combustable wall, a wall shield firestop must be installed.
- When penetrating a combustable ceiling, a ceiling firestop must be installed.
- Horizontal runs of vent do not require vertical rise; horizontal runs may be level.
- Horizontal termination cap should have a 1/4 inch downward slant to allow any moisture in cap to be released. See Figure 4.9.

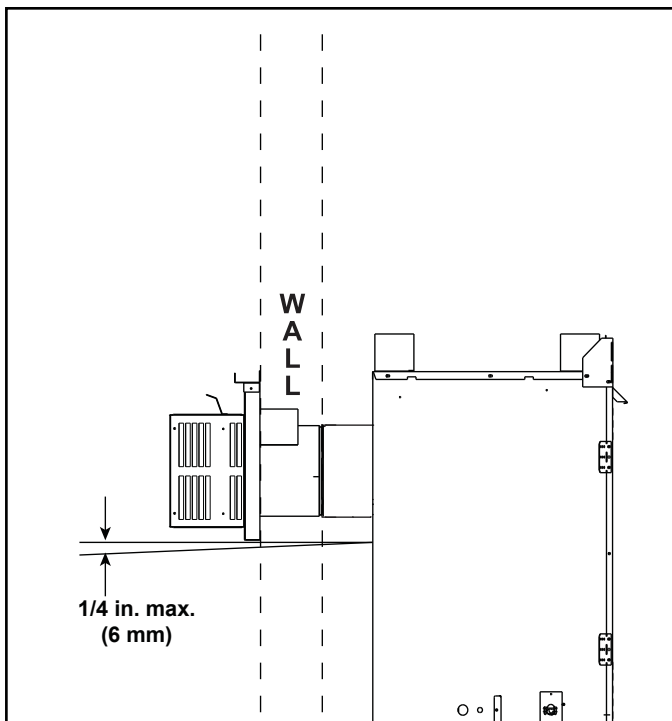

Figure 4.9

Top Vent - Horizontal Termination

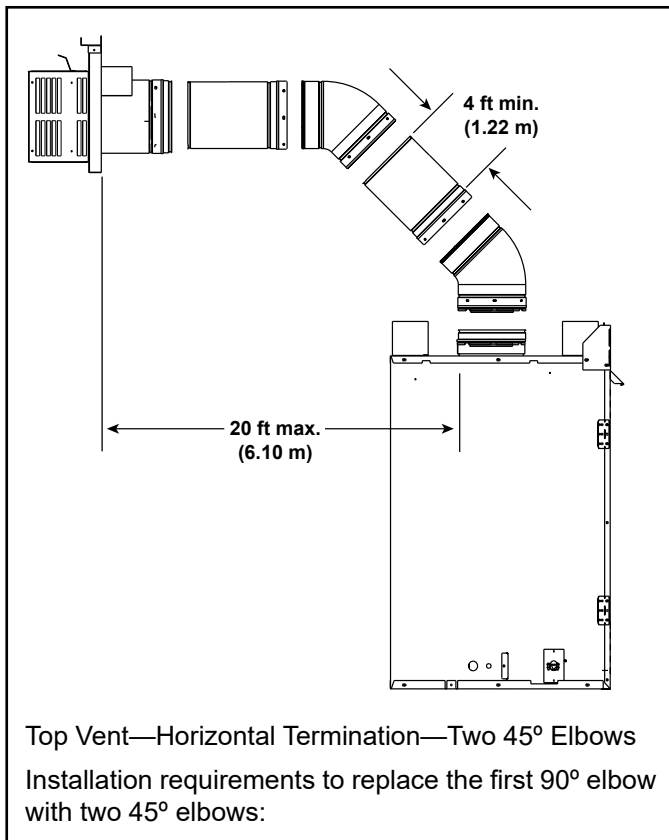

Figure 4.10

Note: The CD series fireplaces can adapt to SLP series vent pipe, if desired.

When venting off the top of the unit, use a DVP-2SL adapter and a minimum 48 inch vertical section of SLP series vent pipe.

A DVP-SLP24 adapter may also be used with a 24 inch vertical section of SLP series vent pipe.

After the 48 inch vertical section, the venting table rules must be followed. The first 48 inch **vertical** section is **NOT** counted as part of the vertical components in the table. It is still counted as part of the overall maximum run. All venting table rules for the vent run must still be followed.

Example: DVP pipe 3 ft. min. vertical = 11 ft. max. horizontal
 SLP pipe 7 ft. min. vertical = 11 ft. max. horizontal

⚠ WARNING



Fire Risk. Explosion Risk.

Do NOT pack insulation or other combustibles between ceiling firestops.

- ALWAYS maintain specified clearances around venting and firestop systems.



- Install wall shield and ceiling firestops as specified.

Failure to keep insulation or other material away from vent pipe may cause fire.

⚠ WARNING



Fire Risk.

- When using DVP-HRC-SS and DVP-HRC-ZC-SS termination caps on top vented fireplaces, a 6 inch minimum vertical vent section is required before installing first elbow.

Top Vent - Horizontal Termination - (continued)

One Elbow

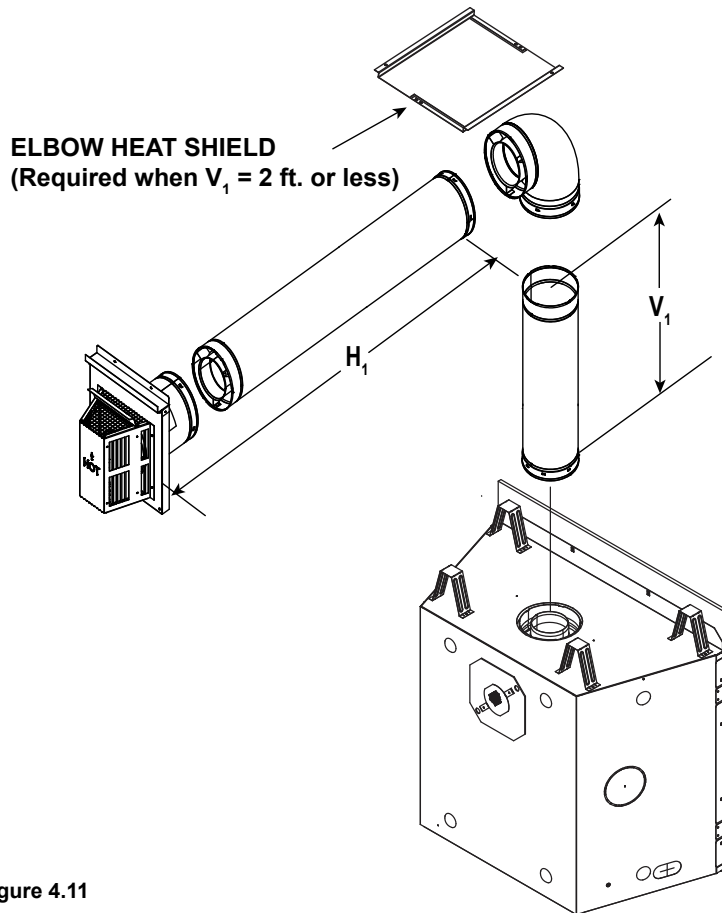

WARNING! Risk of Fire! Elbow heat shield required when $V_1 = 2$ ft. or less. Clearances to combustibles must be maintained. See Section 5.A.

V_1 Minimum		H_1 Maximum	
Elbow only		2 ft	610 mm
1/2 ft.	152 mm	6 ft.	1.8 m
1 ft.	305 mm	11 ft.	3.4 m
1-1/2 ft.	457 mm	18 ft.	5.5 m
2 ft.	610 mm	25 ft.	7.6 m
$V_1 + H_1 = 40$ ft. (12.2 m) Maximum			
$H_1 = 25$ ft. (7.6 m) Maximum			

Note: For corner installations: A 6 in. (152 mm) section of straight pipe may need to be attached to the appliance before a 90° elbow, to allow the vent pipe to clear the top standoffs.

Figure 4.11

Two Elbows

Note: For corner installations: A 6 in. (152 mm) section of straight pipe may need to be attached to the appliance before a 90° elbow, to allow the vent pipe to clear the top standoffs.

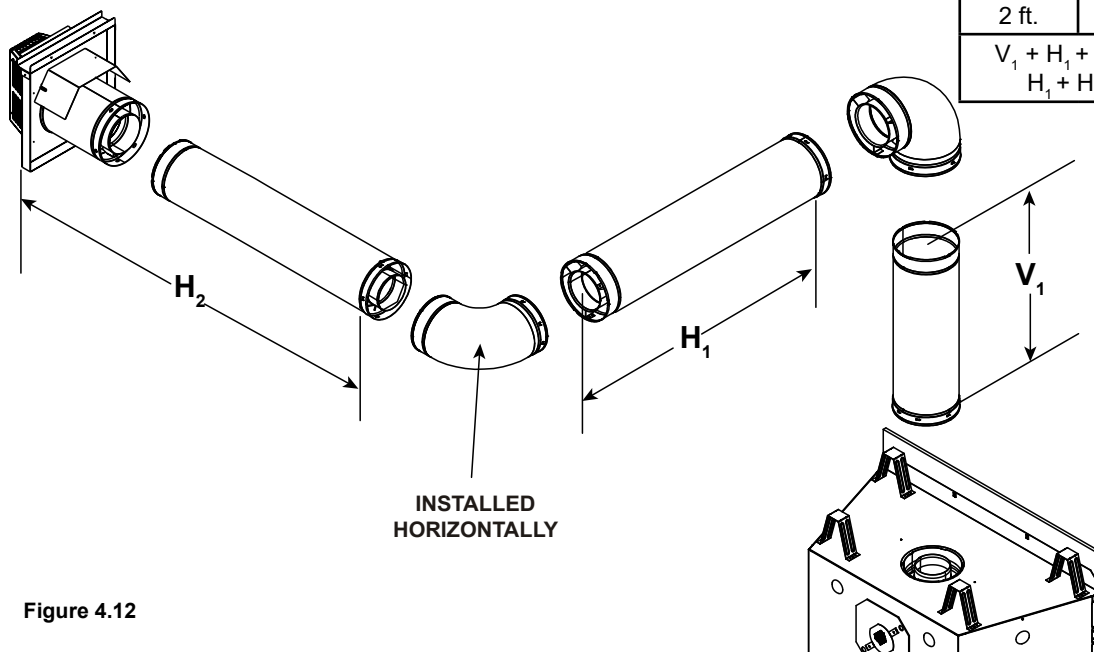

V_1 Minimum		$H_1 + H_2$ Maximum	
Elbow only		2 ft	610 mm
1/2 ft.	152 mm	6 ft.	1.8 m
1 ft.	305 mm	11 ft.	3.4 m
1-1/2 ft.	457 mm	18 ft.	5.5 m
2 ft.	610 mm	25 ft.	7.6 m
$V_1 + H_1 + H_2 = 40$ ft. (12.2 m) Maximum			
$H_1 + H_2 = 25$ ft. (7.6 m) Maximum			

Figure 4.12

Top Vent - Horizontal Termination - (continued)

Three Elbows

V ₁ Min.		H ₁ Max.		V ₂ Min.		H ₂ Max.	
Elbow only		2 ft.	610 mm	0 in.	0 mm	1 ft.	305 mm
6 in.	152 mm	3 ft.	914 mm	6 in.	152 mm	2 ft.	610 mm
1 ft.	305 mm	6 ft.	1.8 m	1 ft.	305 mm	6 ft.	1.8 m
2 ft.	610 mm	11 ft.*	3.4 m*	2 ft.	610 mm	10 ft.*	3.1 m*
3 ft.	914 mm	16 ft.*	4.9 m*	3 ft.	914 mm	14 ft.*	4.3 m*
*H ₁ + H ₂ = 20 ft. (6.1 m) Maximum				V ₁ + V ₂ + H ₁ + H ₂ = 40 ft. (12.2 m) Maximum			

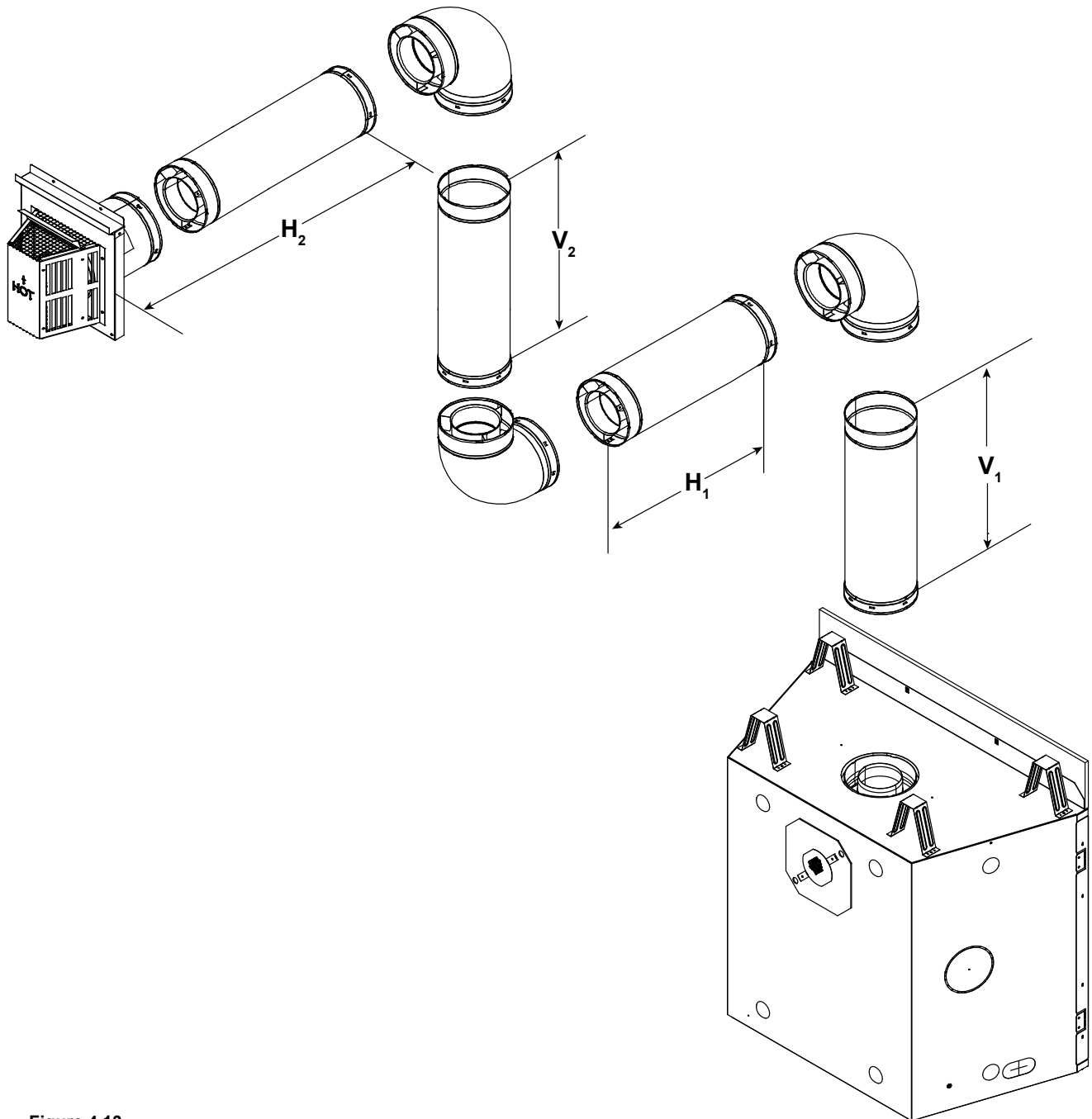

Figure 4.13

Top Vent - Vertical Termination

No Elbow

$V_1 = 60 \text{ ft. Max. (18.3 m)}$
 $V_1 = 3 \text{ ft. Min. (914 mm)}$

Note: If installing a vertical vent/termination off the top of the appliance, the flue restrictor should be used.

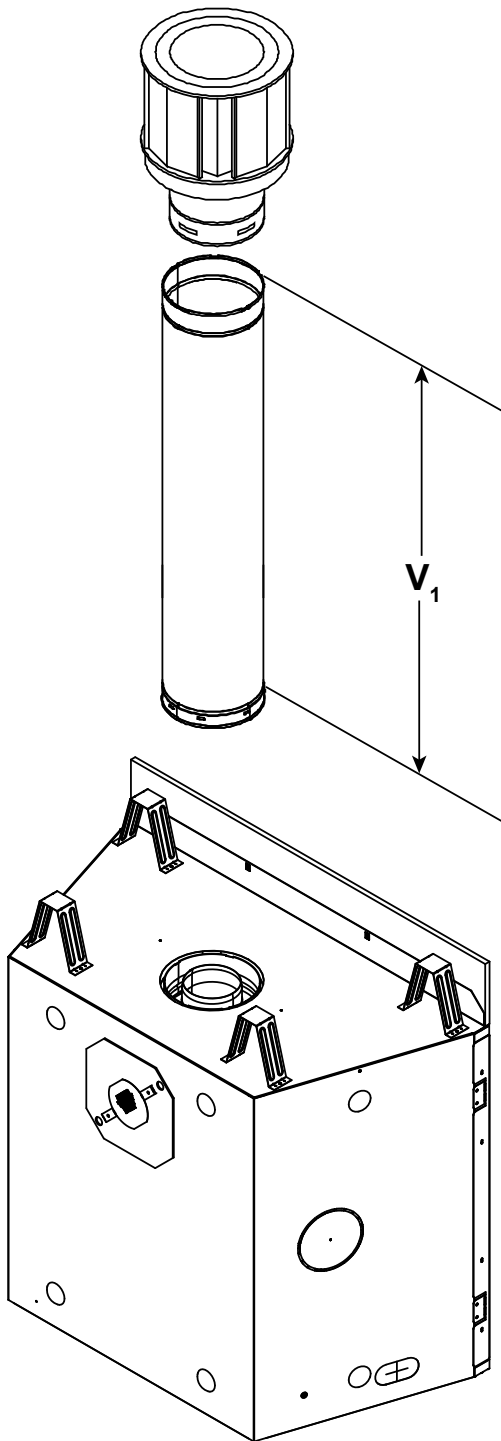

Figure 4.14

Flue Restrictor Instructions

1. Remove exhaust shield using a 1/4 inch nut driver by removing the four screws securing it in place. See Figure 4.15
2. Remove the two flue restrictor components from the manual bag assembly. See Figure 4.17.

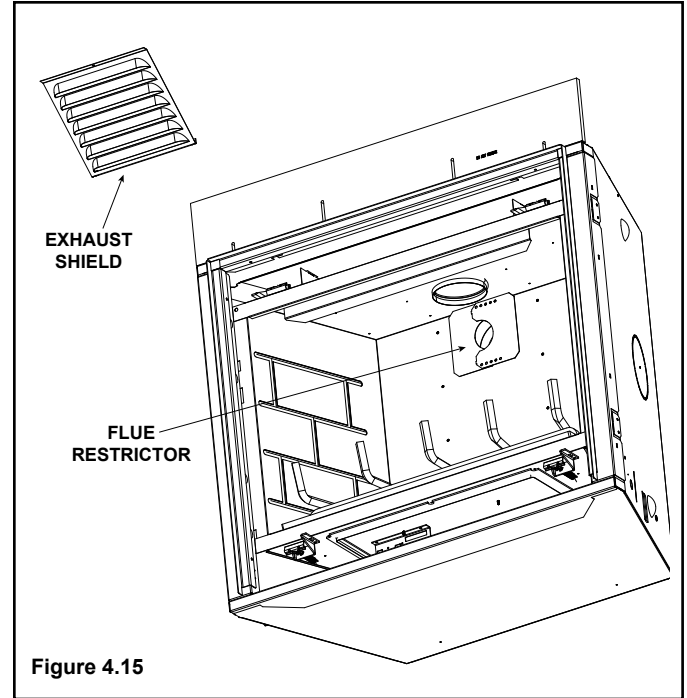

Figure 4.15

3. Match the amount of vertical you have in the system with the chart to find the appropriate position to set the flue restrictor. See Figure 4.16 and Figure 4.17.
4. Center the two flue restrictor pieces on the vent at the setting selected in step 3 and secure in place by using two self-tapping screws. See Figure 4.15.
5. Reinstall the exhaust shield.

Vertical	TOP VENT		REAR VENT	
	NG	Propane	NG	Propane
4 ft.	1-1	No Restrictor	No Restrictor	No Restrictor
8 ft.	2-2	1-2	1-1	No Restrictor
15 ft.	3-3	3-2	2-2	1-2
20 ft.	3-4	3-3	3-3	2-3
25 ft.	3-4	3-3	3-3	2-3
30 ft.	4-4	3-4	3-4	3-3
35 ft.	4-4	3-4	3-4	3-3
40 ft.	4-4	4-4	4-4	3-4
50 ft.+	4-4	4-4	4-4	4-4

Figure 4.16

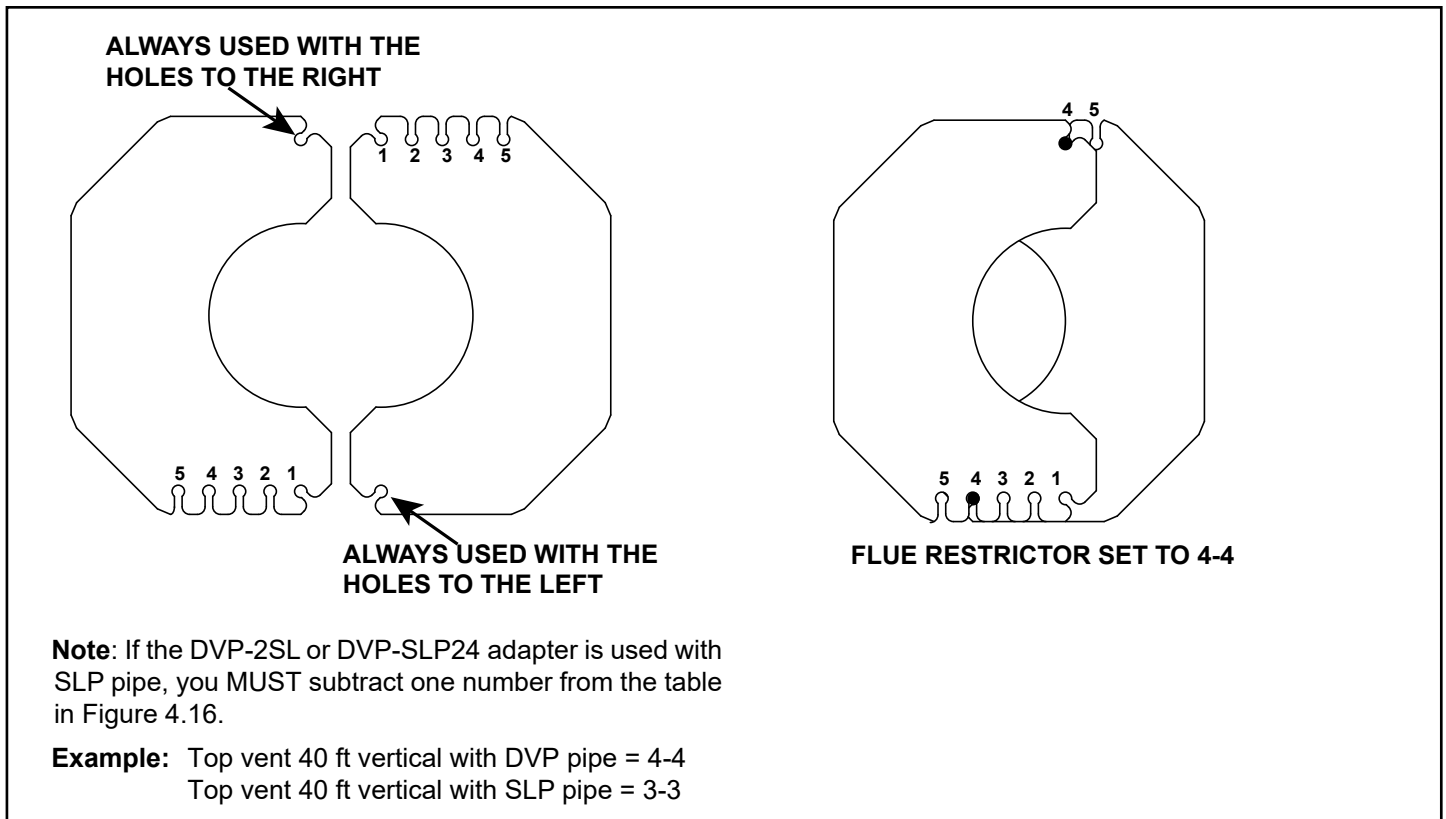
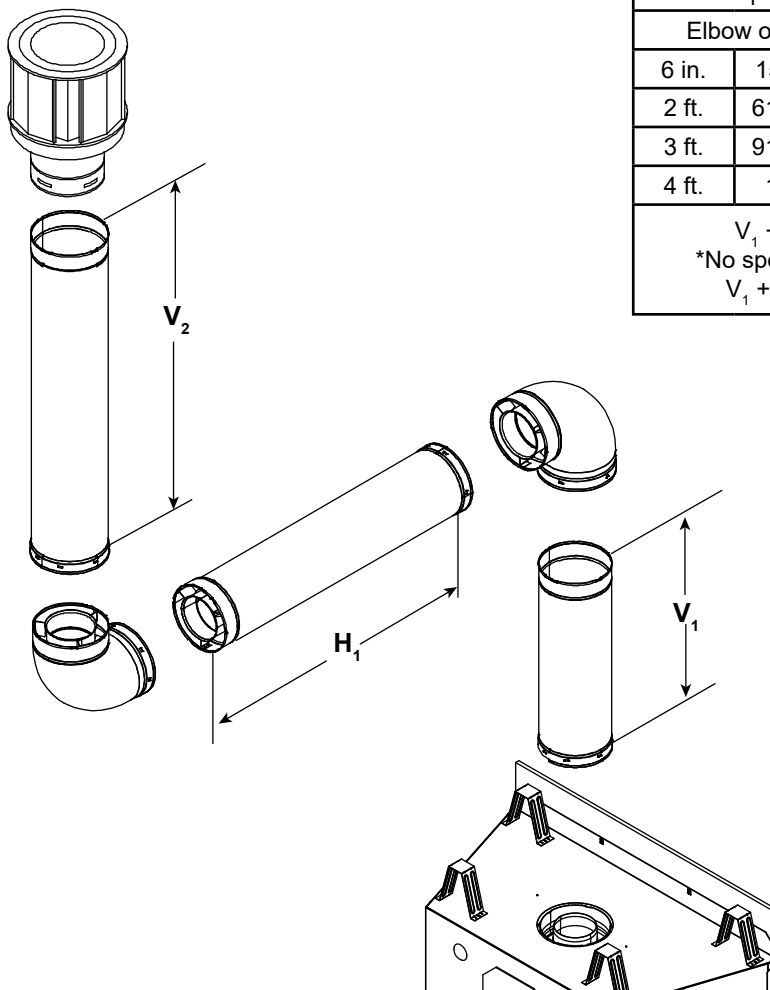

Figure 4.17 Setting the Flue Restrictor

Two Elbows



V_1		H_1 Maximum		V_2	$V_1 + V_2$ Min.	
Elbow only		2 ft.	610 mm	*	*	*
6 in.	152 mm	6 ft.	1.8 m	*	*	*
2 ft.	610 mm	11 ft.	3.4 m	*	*	*
3 ft.	914 mm	16 ft.	4.9 m	*	*	*
4 ft.	1.2 m	20 ft.	6.1 m	*	*	*
$V_1 + V_2 + H_1 = 60$ ft. (18.3 m) Maximum *No specific restrictions on this value EXCEPT $V_1 + V_2 + H_1$ cannot exceed 60 ft (18.3 m)						

Figure 4.18

Top Vent - Vertical Termination - (continued)

Three Elbows

V_1		$H_1 + H_2$		V_2	$V_1 + V_2$ Minimum		$H_1 + H_2$ Maximum	
Elbow only		1 ft.	305 mm	*	*	*	1 ft.	305 mm
6 in.	152 mm	2 ft.	610 mm	*	*	*	2 ft.	610 mm
1 ft.	305 mm	2 ft.	610 mm	*	*	*	2 ft.	610 mm
2 ft.	610 mm	4 ft.	1.2 m	*	*	*	4 ft.	1.2 m
3 ft.	914 mm	9 ft.	2.7 m	*	*	*	9 ft.	2.7 m
4 ft.	1.2 m	18 ft.	5.5 m	*	*	*	18 ft.	5.5 m
$H_1 + H_2 = 20$ ft. (6.1 m) Maximum				$V_1 + V_2 + H_1 + H_2 = 60$ ft. (18.3 m) Maximum				

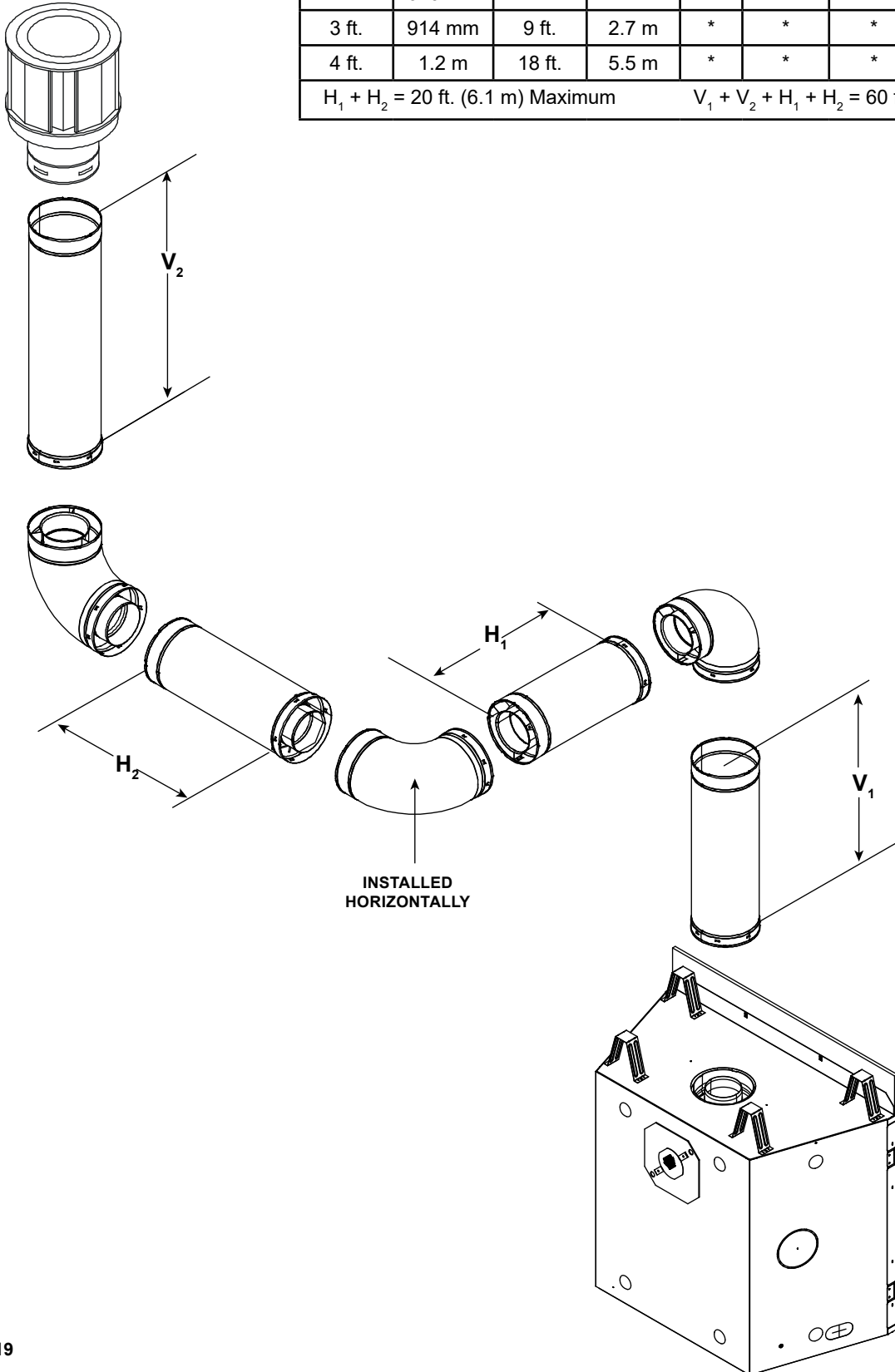

Figure 4.19

Rear Vent - Horizontal Termination

No Elbow

$H_1 = 18 \text{ in. (457 mm)}$ Maximum

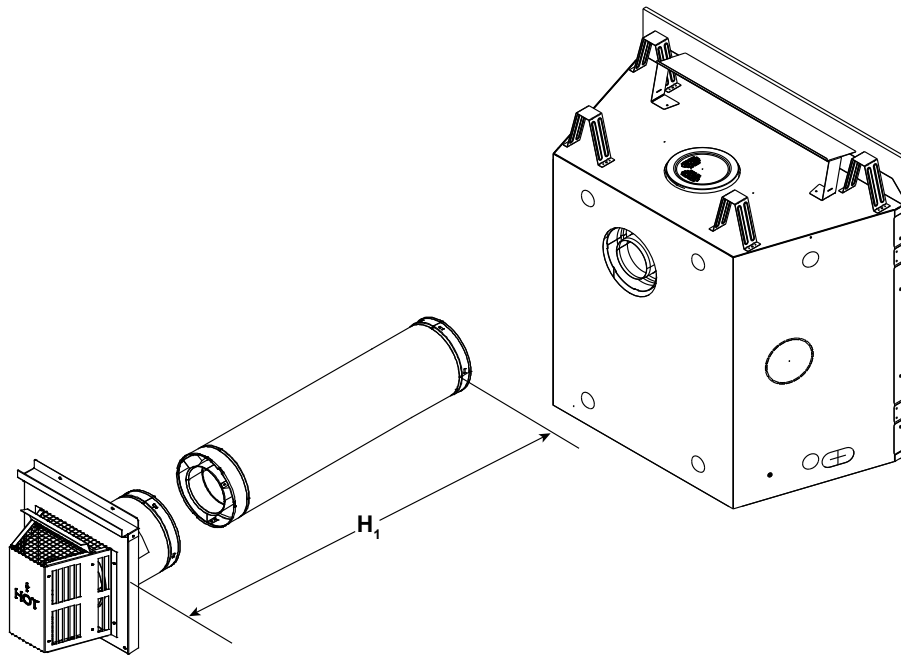

Figure 4.20

One 45° Elbow

$H_1 = 12 \text{ in. (305 mm)}$ Maximum CD4236IR
 $H_1 = 15 \text{ in. (381 mm)}$ Maximum CD4842IR

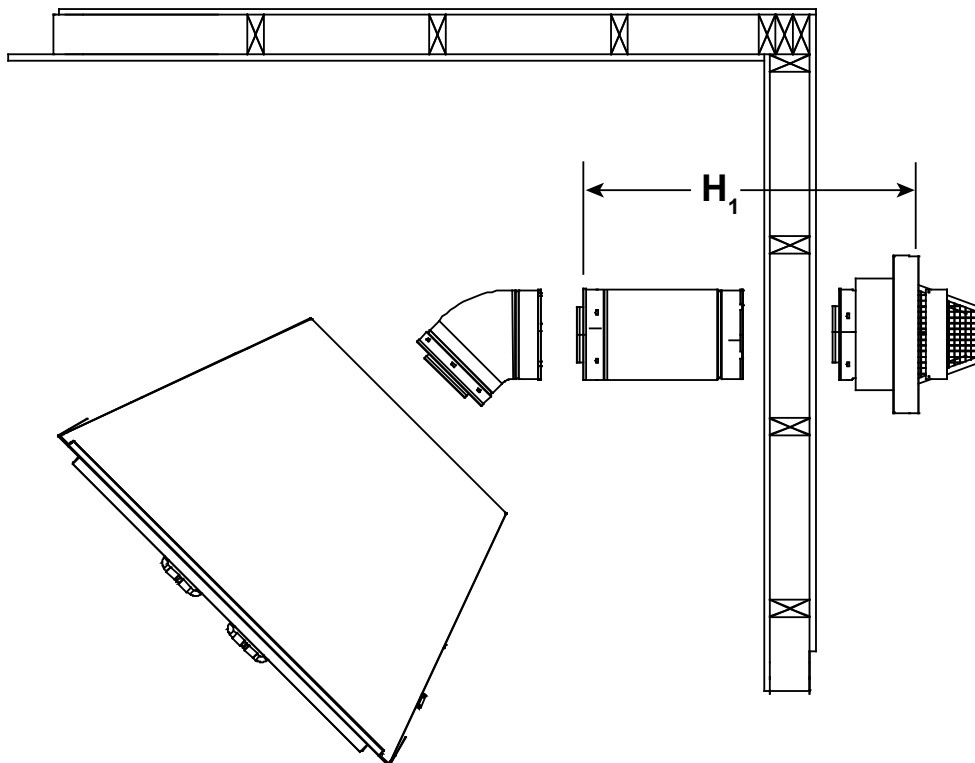

Figure 4.21

Rear Vent - Horizontal Termination - (continued)

Two Elbows

H ₁ Maximum		V ₁ Minimum		H ₂		H ₁ + H ₂ Maximum	
1 ft.	305 mm	Back to Back 90° Elbows		1 ft.	305 mm	2 ft.	610 mm
2 ft.	610 mm	6 in.	152 mm	2 ft.	610 mm	4 ft.	1.2 m
3 ft.	914 mm	1 ft.	305 mm	2 ft.	610 mm	5 ft.	1.5 m
3 ft.	914 mm	2 ft.	610 mm	4 ft.	1.2 m	7 ft.	2.1 m
3 ft.	914 mm	3 ft.	914 mm	9 ft.	2.7 m	12 ft.	3.7 m
3 ft.	914 mm	4 ft.	1.2 m	17 ft.	5.2 m	20 ft.*	6.1 m*

$V_1 + H_1 + H_2 = 40 \text{ ft. (12.2 m) Maximum}$ $H_1 = 3 \text{ ft. (914 mm) Maximum}$
 $*H_1 + H_2 = 20 \text{ ft (6.1 m) Maximum}$

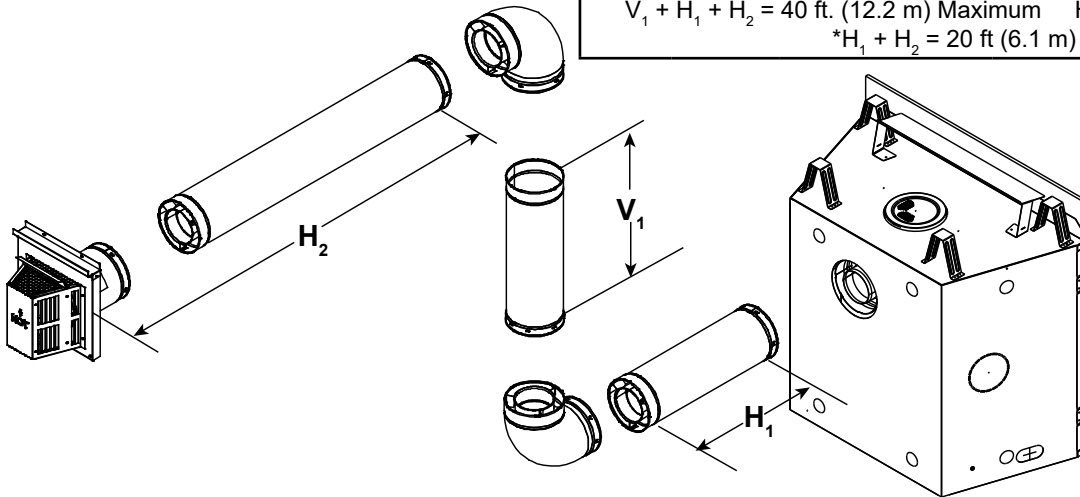

Figure 4.22

Three Elbows

H ₁ Maximum		V ₁ Minimum		H ₂ + H ₃		H ₁ + H ₂ + H ₃ Max.	
1 ft.	305 mm	Back to Back 90° Elbows		1 ft.	305 mm	2 ft.	610 mm
2 ft.	610 mm	6 in.	152 mm	1.5 ft.	457 mm	3.5 ft.	1.1 m
3 ft.	914 mm	1 ft.	305 mm	2 ft.	610 mm	5 ft.	1.5 m
3 ft.	914 mm	2 ft.	610 mm	4 ft.	1.2 m	7 ft.	2.1 m
3 ft.	914 mm	3 ft.	914 mm	9 ft.	2.7 m	12 ft.	3.7 m
3 ft.	914 mm	4 ft.	1.2 m	12 ft.	3.7 m	15 ft.	4.6 m

$V_1 + H_1 + H_2 + H_3 = 40 \text{ ft. (12.2 m) Maximum}$ $H_1 = 3 \text{ ft. (914 mm) Maximum}$
 $H_1 + H_2 + H_3 = 20 \text{ ft. (6.1 m) Maximum}$

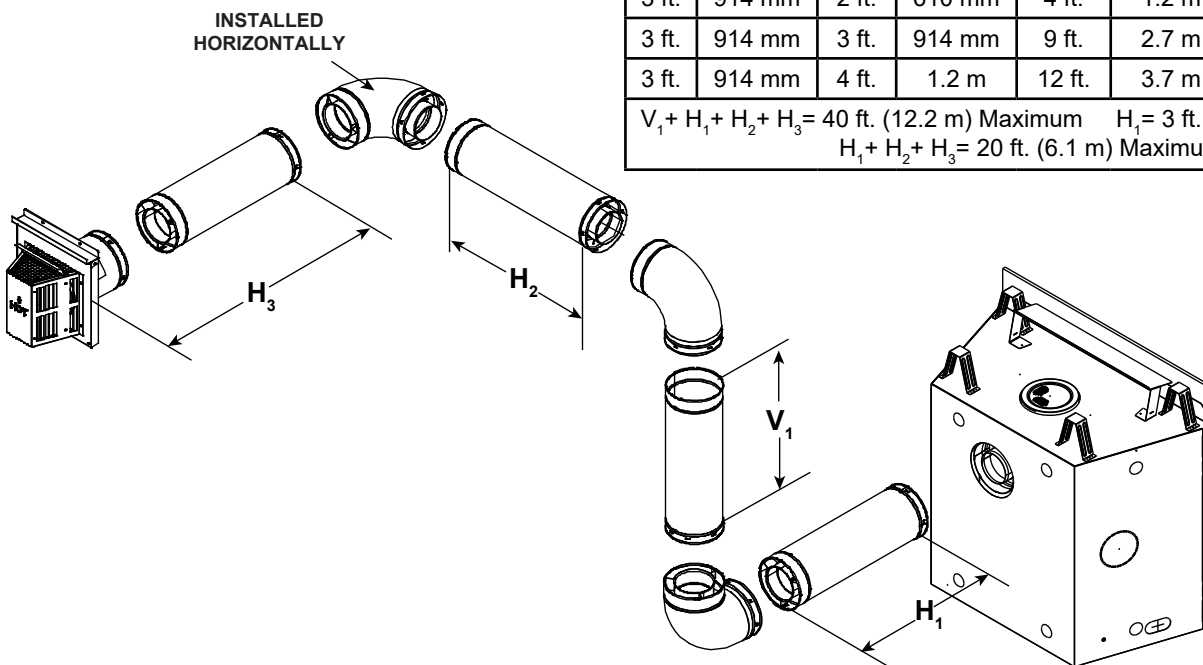
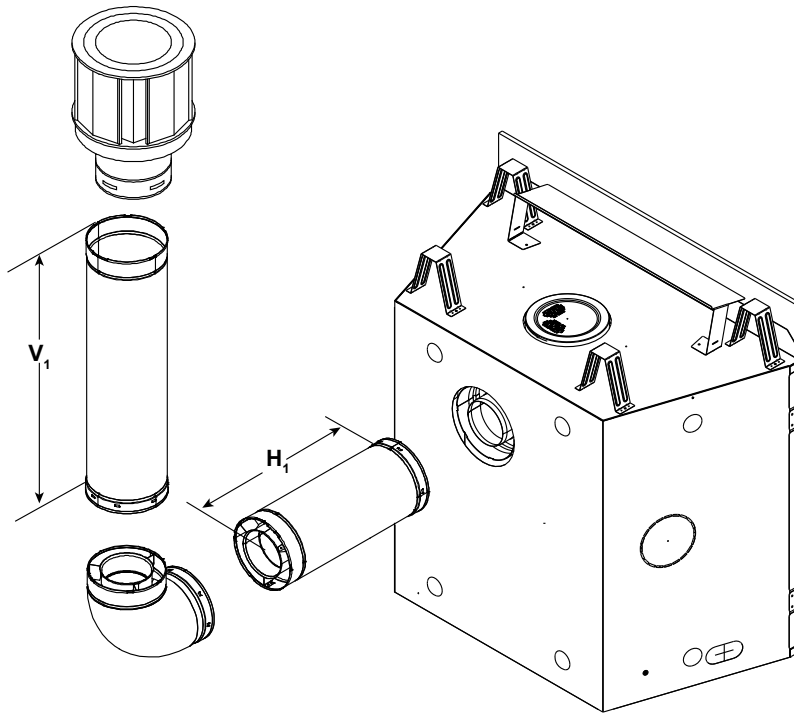

Figure 4.23

Rear Vent - Vertical Termination One Elbow



V ₁ Minimum		H ₁ Maximum	
6 in.	152 mm	2 ft.	610 mm
1 ft.	305 mm	3 ft.	914 mm
2 ft.	610 mm	5 ft.	1.5 m
3 ft.	914 mm	7 ft.	2.1 m
4 ft.	1.2 m	8 ft.	2.4 m
5 ft.	1.5 m	8 ft.	2.4 m
V ₁ + H ₁ = 40 ft. (12.2 m) Maximum			
H ₁ = 8 ft. (2.4 m) Maximum			

Figure 4.24

Two Elbows

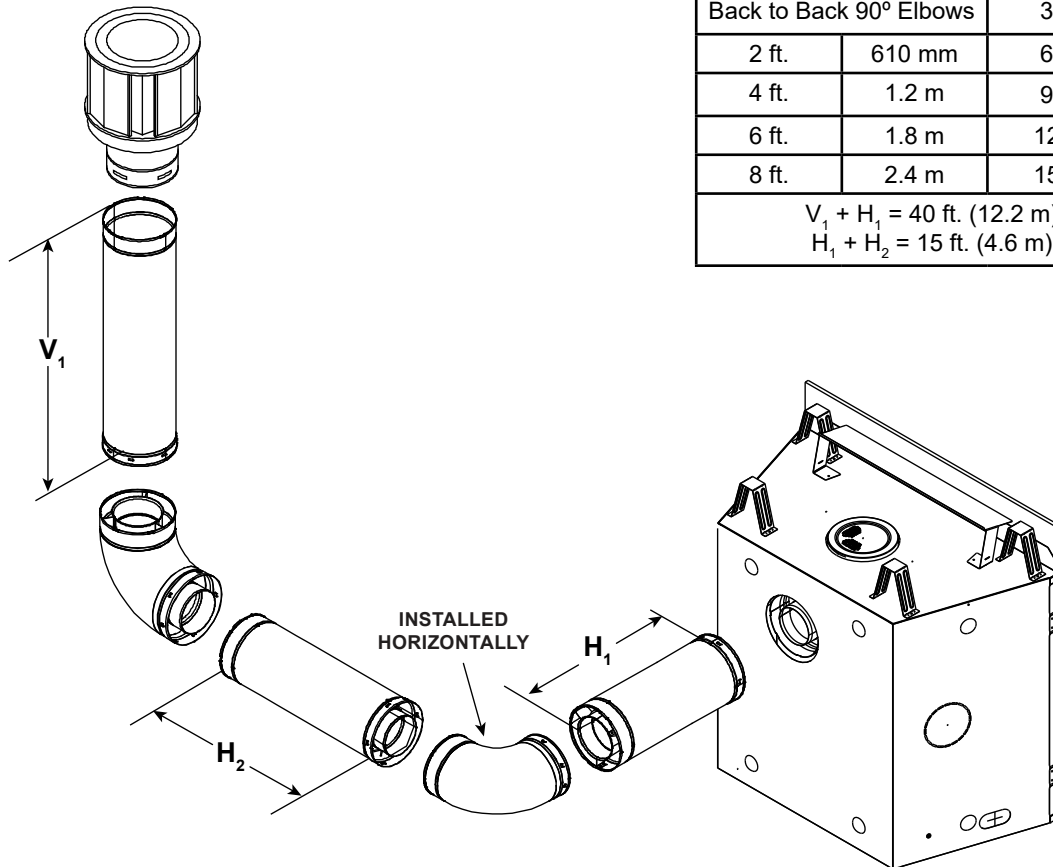

V ₁ Minimum		H ₁ + H ₂ Maximum	
Back to Back 90° Elbows		3 ft.	914 mm
2 ft.	610 mm	6 ft.	1.8 m
4 ft.	1.2 m	9 ft.	2.7 m
6 ft.	1.8 m	12 ft.	3.7 m
8 ft.	2.4 m	15 ft.	4.6 m
V ₁ + H ₁ = 40 ft. (12.2 m) Maximum			
H ₁ + H ₂ = 15 ft. (4.6 m) Maximum			

Figure 4.25

Rear Vent - Vertical Termination - (continued)

Three Elbows

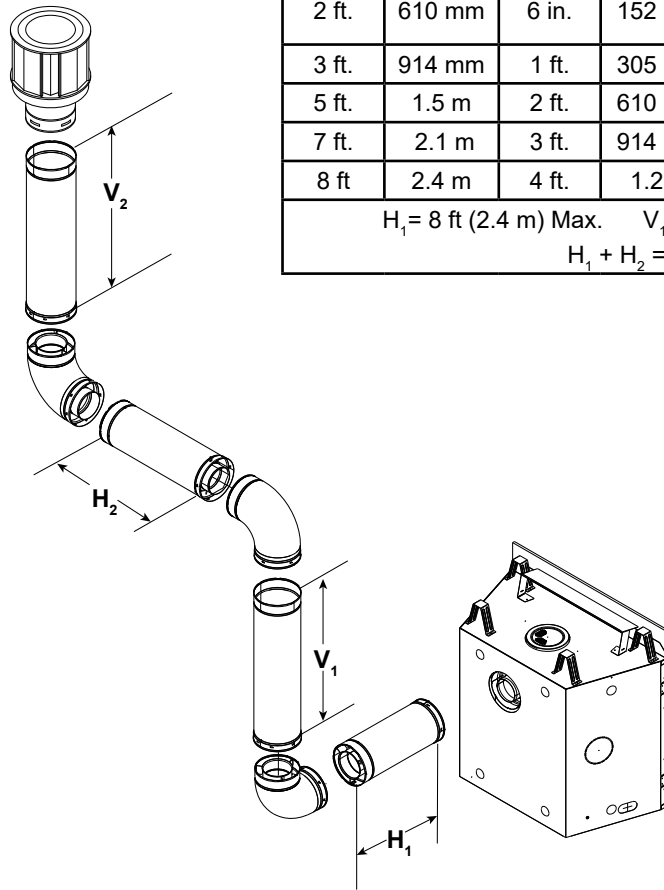

H ₁ Maximum		V ₁ Minimum		H ₂		H ₁ + H ₂ Maximum	
2 ft.	610 mm	6 in.	152 mm	2 ft.	610 mm	4 ft.	1.2 m
3 ft.	914 mm	1 ft.	305 mm	4 ft.	1.2 m	7 ft.	2.1 m
5 ft.	1.5 m	2 ft.	610 mm	6 ft.	1.8 m	11 ft.	3.4 m
7 ft.	2.1 m	3 ft.	914 mm	8 ft.	2.4 m	15 ft.	4.6 m
8 ft.	2.4 m	4 ft.	1.2 m	10 ft.	3.1 m	18 ft.	5.5 m
H ₁ = 8 ft (2.4 m) Max. V ₁ + V ₂ + H ₁ + H ₂ = 40 ft (12.2 m) Max. H ₁ + H ₂ = 20 ft (6.1 m) Max.							

Figure 4.26

Three Elbows

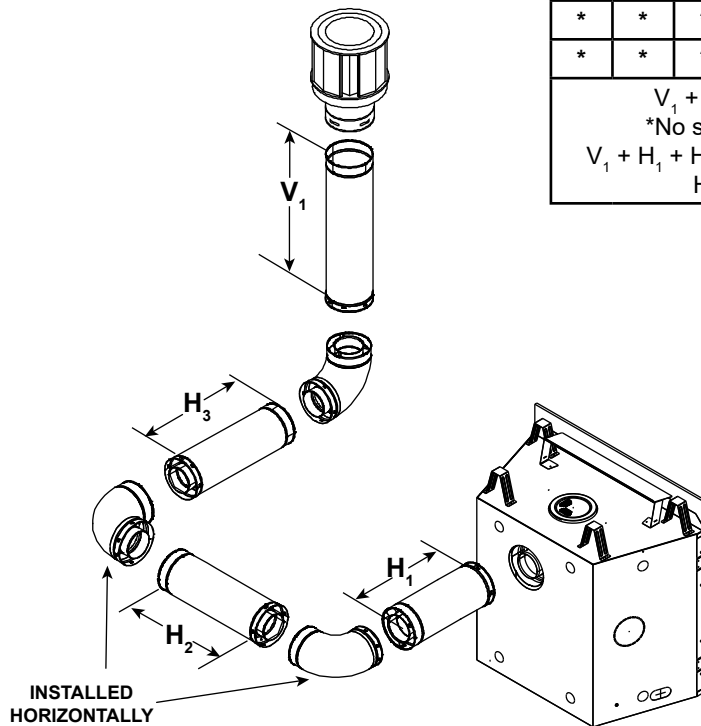

H ₁	H ₂	H ₃	V ₁ Minimum		H ₁ + H ₂ + H ₃ Maximum	
*	*	*	8 ft.	2.4 m	6 ft.	1.8 m
*	*	*	9 ft.	2.7 m	7 ft.	2.1 m
*	*	*	10 ft.	3.1 m	8 ft.	2.4 m
V ₁ + H ₁ + H ₂ + H ₃ = 40 ft. (12.2 m) Maximum *No specific restrictions on this value EXCEPT V ₁ + H ₁ + H ₂ + H ₃ cannot exceed 40 ft. (12.2 m) Maximum H ₁ + H ₂ + H ₃ = 8 ft. (2.4 m) Maximum						

Figure 4.27

Coaxial to Colinear Venting

The coaxial to colinear adapter (DV-46DVA-GCL) is approved for installations into solid fuel masonry or factory built fireplaces that have been installed in accordance with the National, Provincial, State and local building codes. Reference Table 1 for required parts. The DV-46DVA-GCL must be recessed into existing masonry fireplace. See Table 2 and Figure 4.29.

Table 1

REQUIRED PARTS	
DV-46DVA-GCL	Coaxial/Colinear Appliance Connector
LINK-DV30B	Flex Liner Kit
768-380A	Stainless Steel Flex Pipe
DVP-2SL	Adapter (Appliances using DVP pipe)

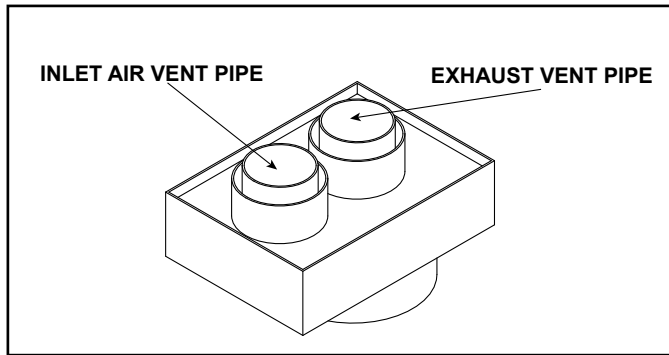

Figure 4.28 Coaxial/Colinear Appliance Connector

WARNING! Risk of Fire! Coaxial to colinear venting configuration may only be used in existing non-combustible chimney. Installation in any other venting application could cause fire.

Prior to installing the gas appliance:

- Have the chimney and adjacent structure inspected and cleaned by qualified professionals. Hearth & Home Technologies recommends that NFI or CSIA certified professionals, or technicians under the direction of certified professionals, conduct a minimum of a NFPA 211 Level 2 inspection of the chimney.
- Replace component parts of the chimney and fireplace as specified by the professionals.
- Ensure all joints are properly engaged and the chimney is properly secured.

Table 2

CLEARANCE TO COMBUSTIBLES REQUIREMENTS	
DV-46DVA-GCL	3 IN.
Exhaust Vent Pipe	5 IN.

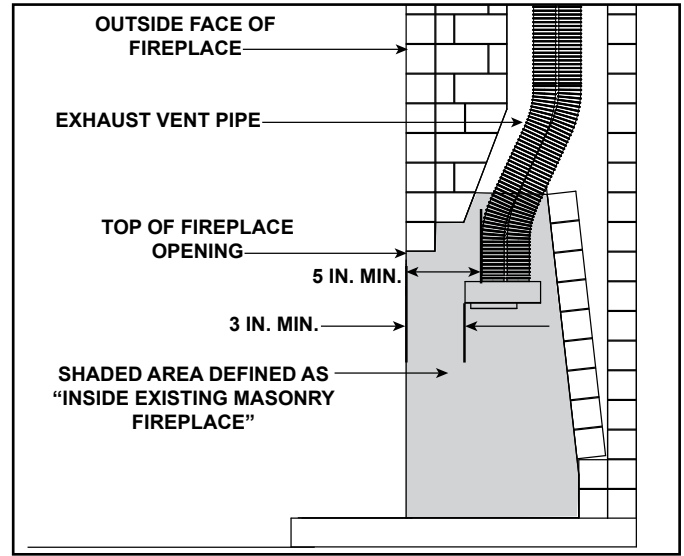

Figure 4.29 Existing Fireplace DV-46DVA-GCL Clearance Requirements

Clearances to Combustibles:

Refer to Section 3 for clearances to the appliance, mantel, mantel legs and wall projection.

Refer to Section 5 for pipe clearances to combustibles.

Termination Cap

For installation of termination cap see minimum vent heights for various pitched roofs. See Section 4.A.

Flue Damper

Fully lock the solid fuel fireplace's flue damper in the open position, OR completely remove it.

Venting Components

The LINK-DV30B is approved for use with the coaxial/colinear venting application. The LINK-DV30B kit includes:

- Two 30 foot sections of flexible vent pipe (3 inches Ø). One section is used to draw combustion air and the other section is used to expel exhaust gases.
- One vertical termination cap.

CAUTION! DO NOT use any flue restrictor when venting with the DV-46DVA-GCL adapter and LINK-DV30B kit. This could result in poor flame appearance, sooting, pilot malfunction, or overheating.

Connecting the DV-46DVA-GCL Adapter to Appliance

Top Vent

- Remove top seal cap and insulation if equipped. See Section 6, "Appliance Preparation." Attach the DVP-2SL to the 8 inch starting collar. Follow installation instructions included with DVP-2SL kit. Attach the DV-46DVA-GCL adapter to the appliance starting collar with 3-1/2 in. self-tapping screws. See Figure 4.30.

Rear Vent

- Remove the rear seal cap and insulation if equipped. Connect the DVP-2SL adapter to the vertically positioned elbow. Follow installation instructions included with DVP-2SL kit. Secure DV-46DVA-GCL adapter to DVP-2SL with 3-1/2 in. self-tapping screws. See Figure 4.30.

Connecting the LINK-DV30B to the DV-46DVA-GCL adapter

- Insert the two sections of flexible vent pipe down the existing chimney.
- Attach one section of stainless steel flex pipe to the exhaust collar on top of the DV-46DVA-GCL adapter with three screws.

- Attach one section of flexible vent pipe to the stainless steel flex pipe with three self-tapping screws.
- Attach one section of flexible vent pipe to the inlet collar on top of the DV-46DVA-GCL adapter with three self-tapping screws.
- To minimize cold air drafts, seal around the flex vents at the damper inside the chimney with non-combustible unfaced fiberglass or rock wool insulation.

The DV-46DVA-GCL adapter must be recessed into existing masonry fireplace. This measurement is taken from the top of the fireplace opening. See Table 2 and Figure 4.29.

WARNING! Risk of Fire, Explosion or Asphyxiation!
Do NOT connect this gas appliance to a chimney flue serving a separate solid fuel or gas burning appliance.

- Could impair safe operation of this appliance or other appliances connected to the flue.
- Vent this appliance directly outside.
- Use separate vent system for this appliance.

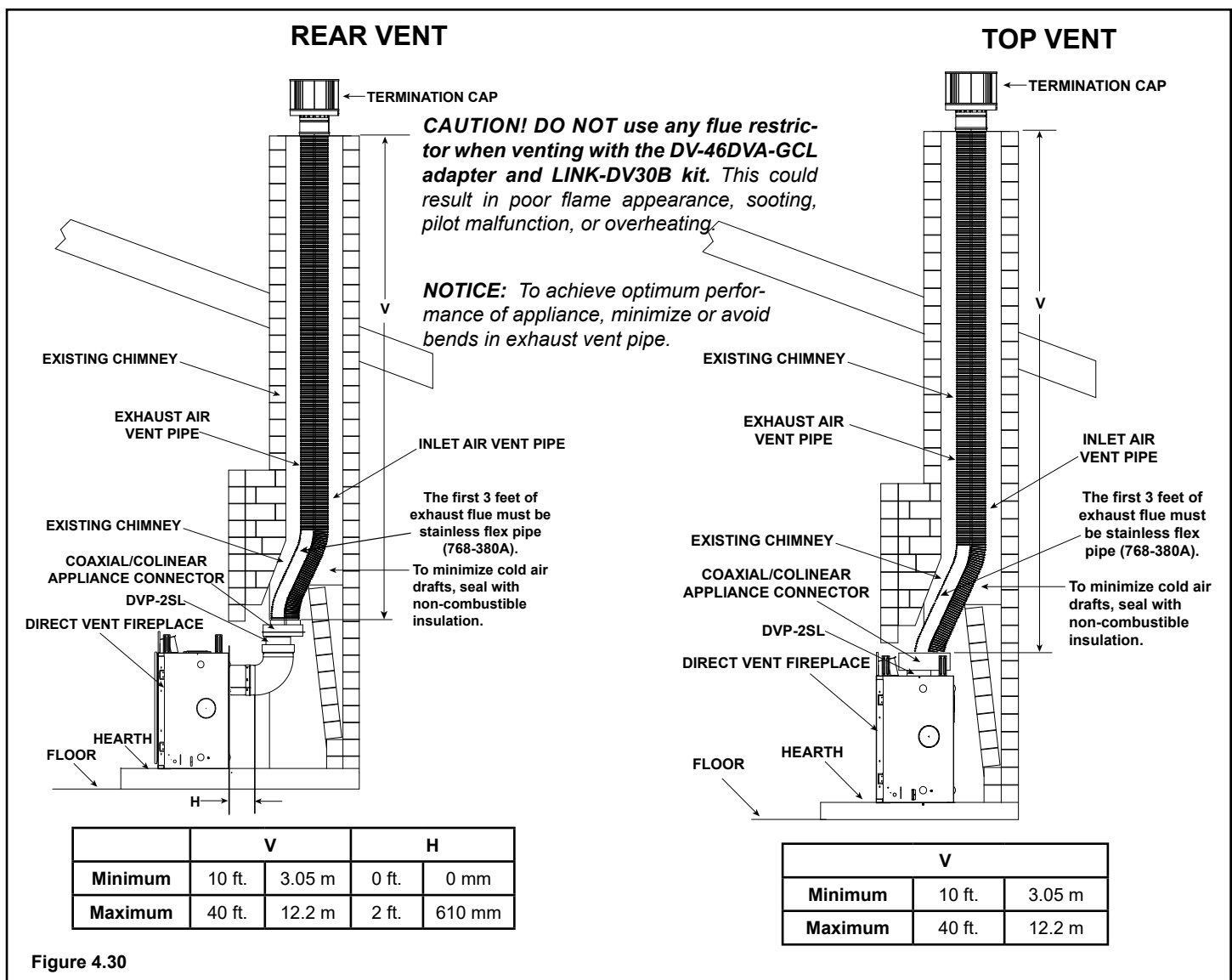

Figure 4.30

5 Vent Clearances and Framing

A. Pipe Clearances to Combustibles

WARNING! Risk of Fire! Maintain air space clearance to vent. DO NOT pack insulation or other combustibles:

- Between ceiling firestops
- Between wall shield firestops
- Around vent system

Failure to keep insulation or other material away from vent pipe could cause overheating and fire.

WARNING! Risk of Fire! Elbow heat shield required when $V_1 = 2$ ft. or less. Clearances to combustibles must be maintained. See Figure 4.11.

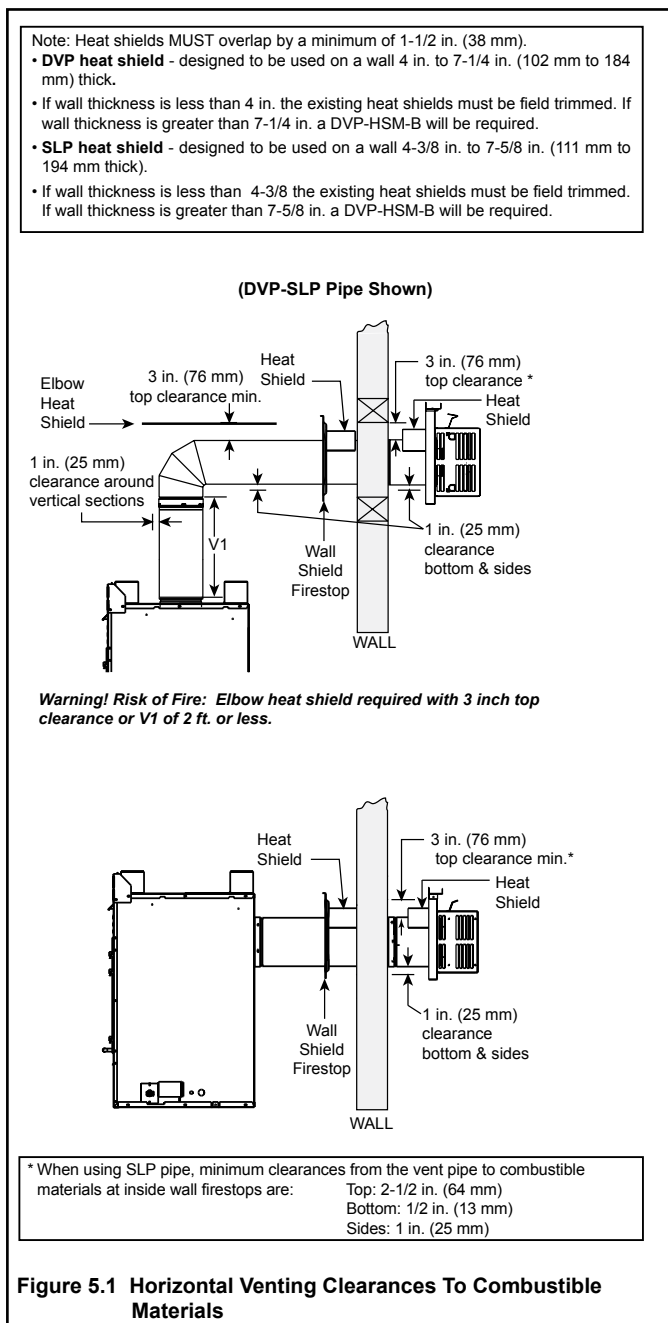

Figure 5.1 Horizontal Venting Clearances To Combustible Materials

B. Wall Penetration Framing/Firestops

Combustible Wall Penetration

Whenever a combustible wall is penetrated, you must frame a hole for the wall shield firestop(s). The wall shield firestop maintains minimum clearances and prevents cold air infiltration.

- The opening must be framed on all four sides using the same size framing materials as those used in the wall construction.
- SLP pipe - A wall shield firestop must be placed on each side of an interior wall. A minimum 1-1/2 in. (38 mm) overlap of attached heat shields must be maintained.
- DVP pipe - A wall shield firestop is required on one side only on interior walls. If your local inspector requires a wall shield firestop on both sides, then both wall shield firestops must have a heat shield (refer to Section 12.A) attached to them.
- See Section 7.G for information for regarding the installation of a horizontal termination cap.

Non-Combustible Wall Penetration

If the hole being penetrated is surrounded by non-combustible materials such as concrete, a hole with diameter one inch greater than the pipe is acceptable.

Whenever a non-combustible wall is penetrated, the wall shield firestop is only required on one side and no heat shield is necessary.

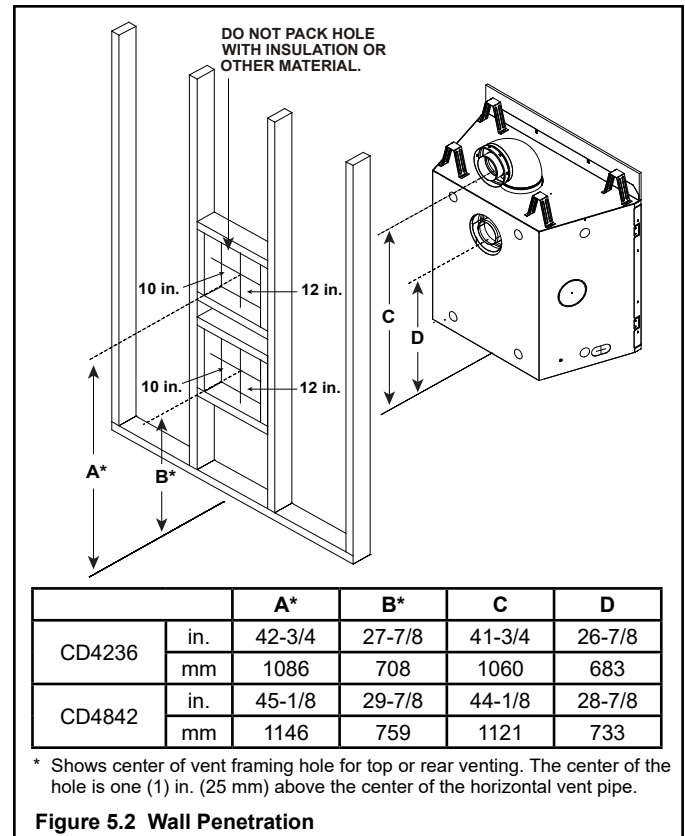

Figure 5.2 Wall Penetration

C. Ceiling Firestop/Floor Penetration Framing

A ceiling firestop **MUST** be used between floors and attics.

- **DVP pipe only** - Frame an opening 10 in. by 10 in. (254 mm by 254 mm) whenever the vent penetrates a ceiling/floor (see Figure 5.3).
- **SLP pipe only** - Frame opening 9 in. x 9 in. (229 mm x 229 mm) whenever the vent penetrates a ceiling/floor (see Figure 5.3).
- Frame the area with the same sized lumber as used in ceiling/floor joist.
- The ceiling firestop may be installed above or below the ceiling joists when installed with an attic insulation shield. It must be under joists between floors that are not insulated. Refer to Figure 5.4.
- Secure in place with nails or screws.

WARNING! Risk of Fire! DO NOT pack insulation around the vent. Insulation must be kept back from the pipe to prevent overheating.

D. Install Attic Insulation Shield

WARNING! Fire Risk. DO NOT allow loose materials or insulation to touch vent. Hearth & Home Technologies requires the use of an attic shield.

The International Fuel Gas Code requires an attic shield constructed of 26 gauge minimum steel that extends at least 2 in. (51 mm) above insulation.

- Attic insulation shields must meet specified clearances to combustible materials and be secured in place.
- An attic insulation shield kit is available from Hearth & Home Technologies. Contact your dealer to order. Install attic insulation shield according to instructions included with kit.

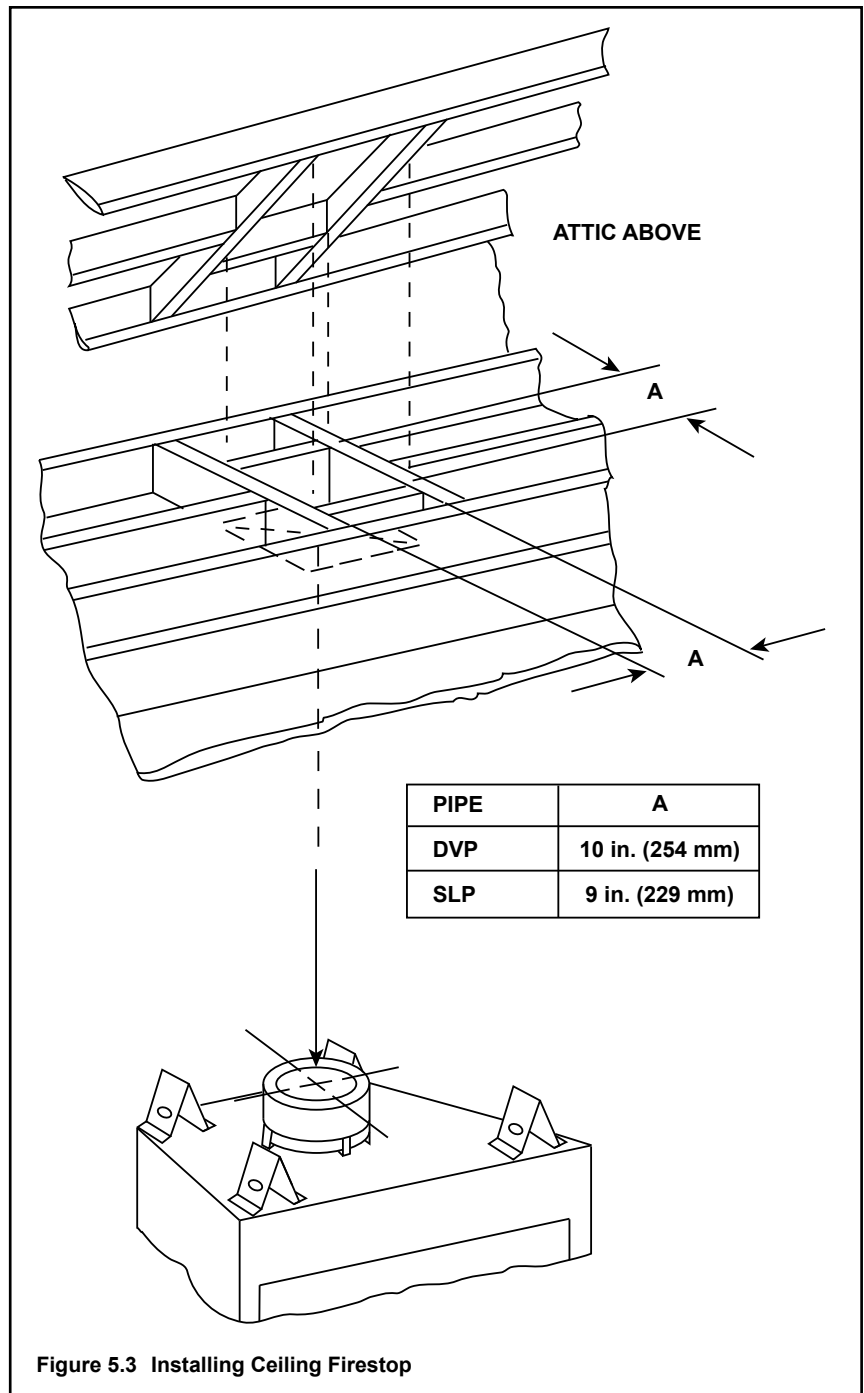

Figure 5.3 Installing Ceiling Firestop

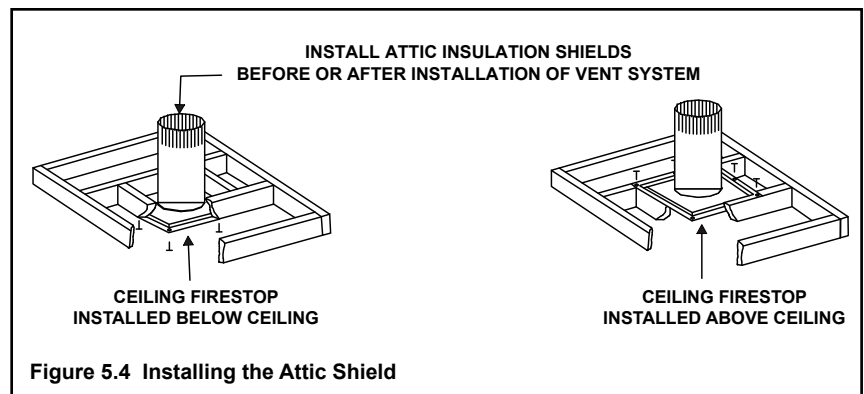

Figure 5.4 Installing the Attic Shield

6 Appliance Preparation

A. Vent Collar Preparation

CAUTION! Risk of Cuts, Abrasions or Flying Debris. Wear protective gloves and safety glasses during installation. Sheet metal edges are sharp.

NOTICE: Once appliance is set up for top or rear venting, it **CANNOT** be changed at a later time.

Top Vent

Note: Instructions for rear vented models on next page.

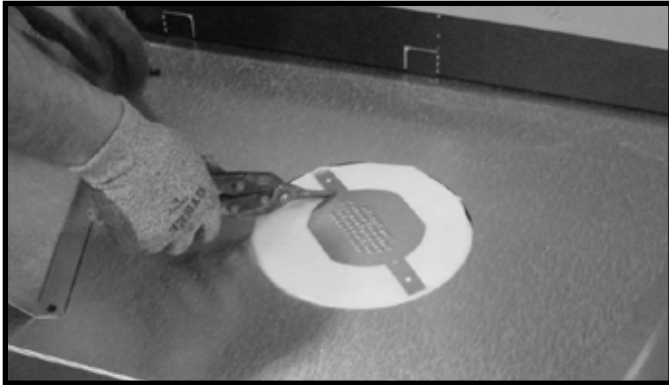

Figure 6.1 (Generic Fireplace Shown) Cut the seal cap strap across the rectangles next to the disk.

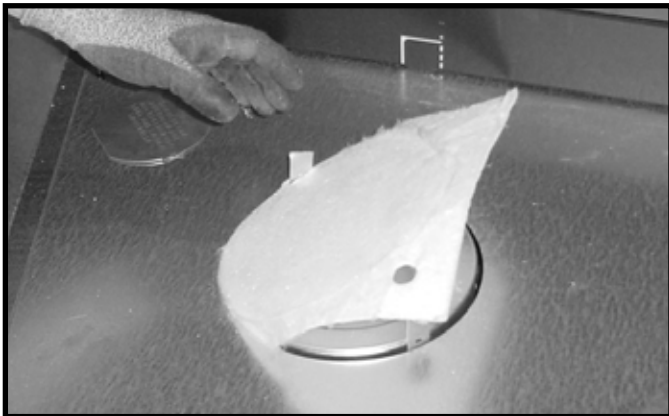

Figure 6.2 (Generic Fireplace Shown) Remove the white gasket material covering the seal cap.

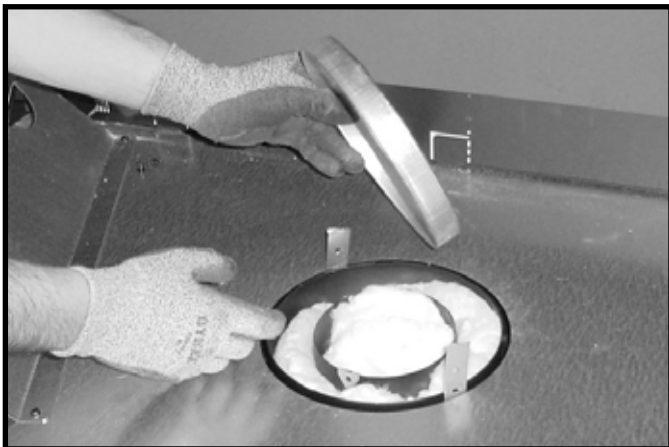

Figure 6.3 (Generic Fireplace Shown) Remove the seal cap.

NOTICE: Once the seal cap has been removed it **CANNOT** be reattached.



Figure 6.4 (Generic Fireplace Shown) Remove the insulation basket and white insulation from the center vent pipe.

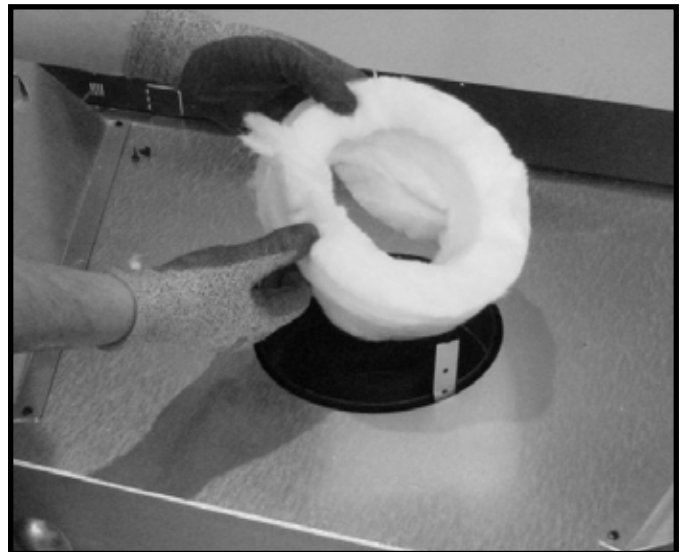

Figure 6.5 (Generic Fireplace Shown) Remove the insulation from the outer vent pipe.

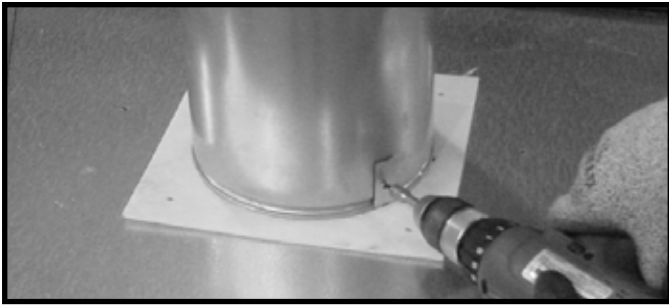

Figure 6.6 (Generic Fireplace Shown) To attach the first section of vent pipe, make sure to use the fiberglass gasket in the manual bag to seal between the first vent component and the outer fireplace wrap. Use 2 self tapping screws to secure the gasket to the outer wrap.

Secure the first section of venting to the fireplace by screwing through the two straps left over from cutting the seal cap strap. See Figure 6.6.

Rear Vent

CAUTION! Risk of Cuts, Abrasions or Flying Debris. Wear protective gloves and safety glasses during installation. Sheet metal edges are sharp.

NOTICE: Once appliance is set up for top or rear venting, it CANNOT be changed at a later time.

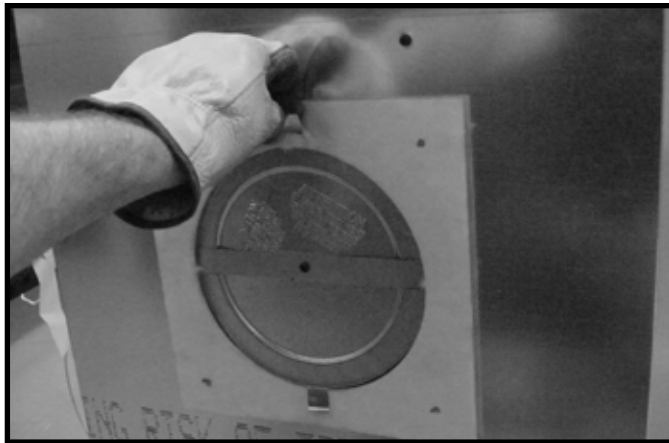

Figure 6.7 (Generic Fireplace Shown) Fold the tabs toward the center of the seal cap (90°) and remove the insulation gasket.



Figure 6.8 (Generic Fireplace Shown) Cut the metal retaining band and fold the sides out.



Figure 6.9 (Generic Fireplace Shown) Fold the center parts of the retaining band out and use to remove the seal cap.

NOTICE: Once the seal cap has been removed it CANNOT be reattached.

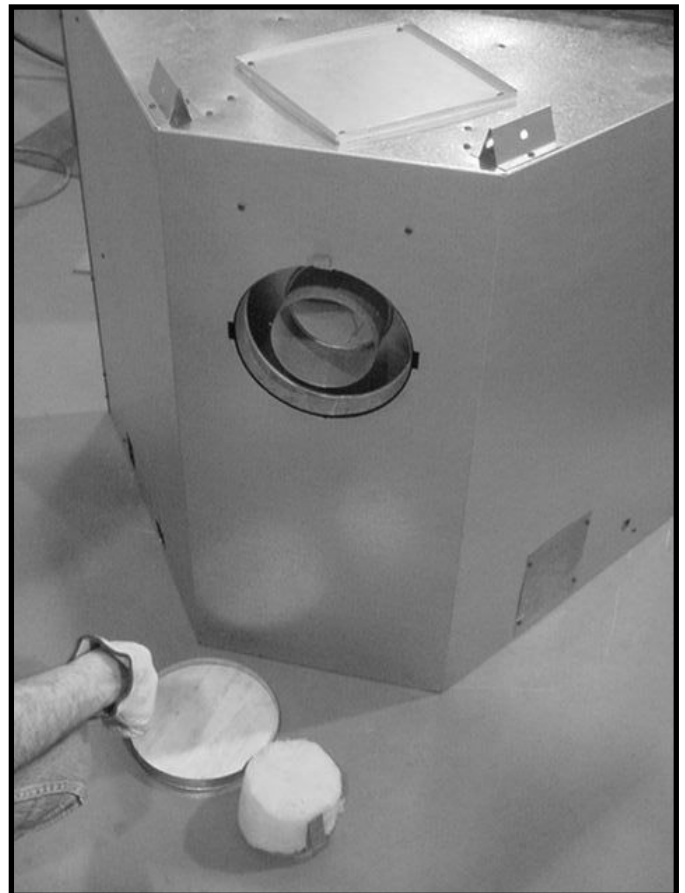
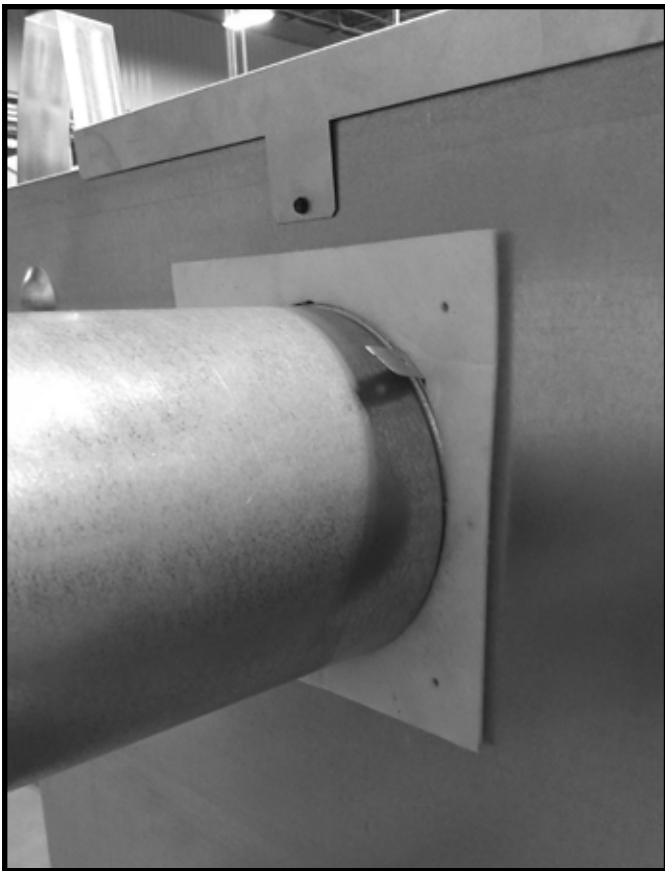

Figure 6.10 (Generic Fireplace Shown) Discard the vent cap, remove and discard the insulation basket.



B. Installing Optional Heat Management Systems

NOTICE: Additional clearances are required for heat management systems installations. Provisions must be made in advance to ensure fit within the framing.

- Locate the heat management ports on the left and right sides of the appliance. Either one or two Heat-Zone® -Gas Kits may be installed. Remove the knockout from the fireplace and discard it. See Figure 6.12.
- Center the duct collar around the exposed hole and attach it to the fireplace with 3 screws.

Note: Do this BEFORE final positioning of fireplace.

- Determine the location for the air register/fan housing assembly.

Reference the appropriate instructions included with the kit for the remaining installation steps.

Figure 6.11 (Generic Fireplace Shown) Attach the first vent section (it will snap into place). Slide the insulation gasket (shipped in the manual bag) onto the vent section, up against the appliance and over the tabs.

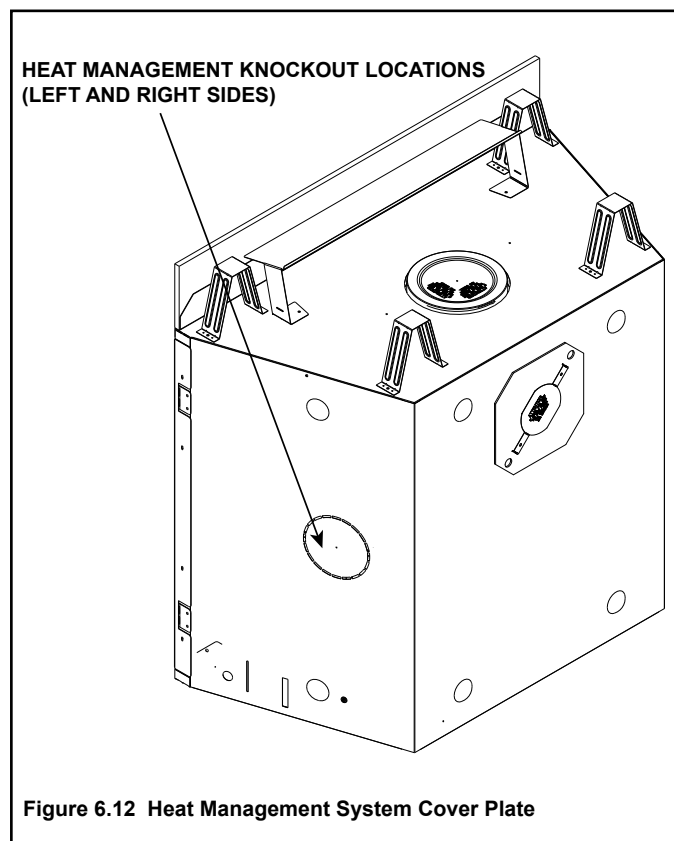

Figure 6.12 Heat Management System Cover Plate

C. Securing and Leveling the Appliance

WARNING! Risk of Fire! Prevent contact with:

- Sagging or loose insulation
- Insulation backing or plastic
- Framing and other combustible materials

Block openings into the chase to prevent entry of blown-in insulation. Make sure insulation and other materials are secured.

DO NOT notch the framing around the appliance standoffs.

Failure to maintain air space clearance may cause overheating and fire.

The diagram shows how to properly square and position, and secure the appliance. See Figures 6.13 and 6.14. Nailing tabs are provided to secure the appliance to the framing members.

- Bend out nailing tabs on each side.
- Place the appliance into position.
- Keep nailing tabs flush with the framing.
- Level the appliance from side to side and front to back.
- “Square” the unit by securing diagonal dimensions to within 1/4 inch of each other. See Figure 6.13.
- Shim the appliance as necessary. It is acceptable to use wood shims underneath the appliance.
- Secure the appliance to the framing by using nails or screws through the nailing tabs.
- Secure the appliance to the floor by inserting two screws through the pilot holes at the bottom of the appliance.
- Optional: Secure the appliance to the floor by inserting two screws through the pilot holes at the bottom of the appliance.

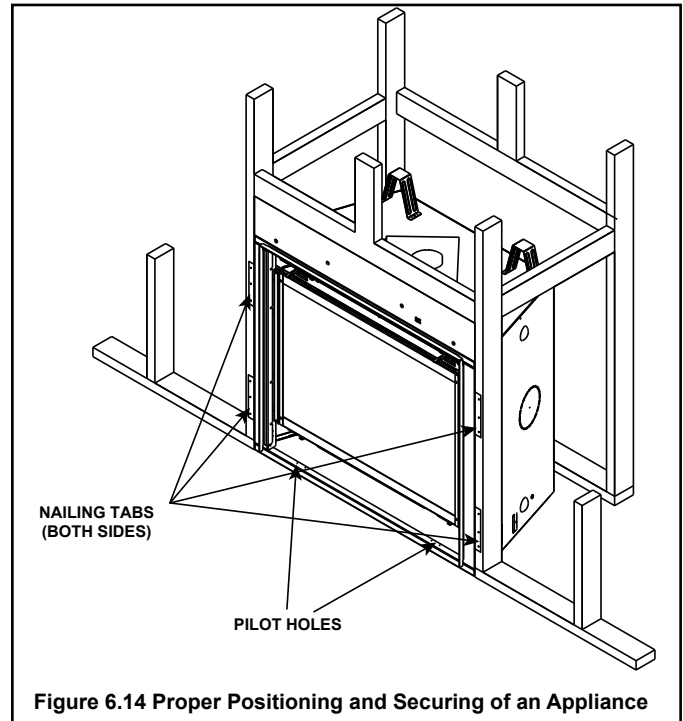

Figure 6.14 Proper Positioning and Securing of an Appliance

D. Installing the Non-combustible Board

The factory supplied non-combustible board spans the distance from the top of the fireplace to the center of the framing header. This board must be used. See Figure 6.15.

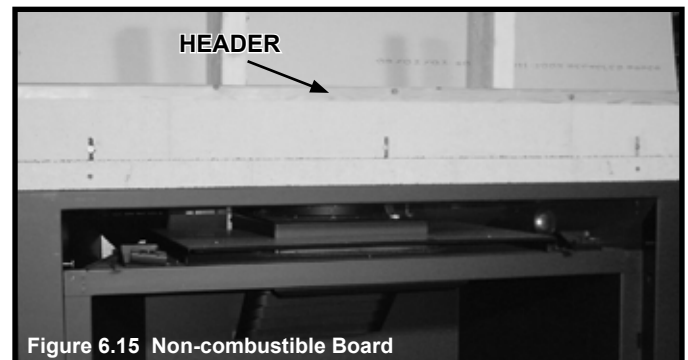
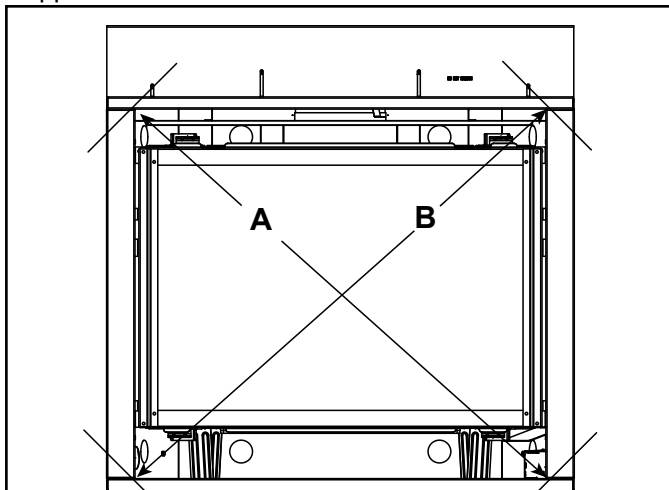

Figure 6.15 Non-combustible Board



Note: Diagonal dimensions (A) and (B) must be within 1/4 inch of each other.

Figure 6.13 Positioning the Appliance Squarely

7 Venting and Chimneys

A. Assemble Vent Sections (DVP Pipe Only)

Attach Vent to the Firebox Assembly

Note: The end of the pipe sections with the lanced tabs will face toward the appliance.

Attach the first pipe section to the starting collar:

- Lanced pipe end of the starting collar.
- Inner pipe over inner collar.
- Push the pipe section until all lanced tabs snap in place.
- Lightly tug on pipe to confirm it has locked.

Required Commercial, Multi-family (Multi-level exceeding two stories), or High-Rise Applications

All outer pipe joints must be sealed with 100% silicone (300 °F minimum continuous exposure rating), including the slip section that connects directly to the horizontal termination cap.

- Apply a bead of silicone sealant (300 °F minimum continuous exposure rating) inside the female outer pipe joint prior to joining sections. See Figure 7.1. **OR**

Apply a bead of silicone sealant (300 °F minimum continuous exposure rating) to the outside of connecting joint after joining sections **OR**

Apply aluminum foil tape (300 °F minimum continuous exposure rating) to the outside of connecting joint after joining sections. On horizontal pipe runs, it is recommended that the tape seam is positioned on the bottom side of the vent pipe.

- Only outer pipes need to be sealed. All unit collar, pipe, slip section, elbow and cap outer flues shall be sealed in this manner, unless otherwise stated.

WARNING! Risk of Fire or Explosion! DO NOT break silicone seals on slip sections. Use care when removing termination cap from slip pipe. If slip section seals are broken during removal of the termination cap, vent could leak.

Assemble Pipe Sections

Per Figure 7.2:

- Start the inner pipe on the lanced end of section A into the flared end of section B.
- Start the outer pipe of section A over the outer pipe of section B.
- Once both vents sections are started, push firmly until all lanced tabs lock into place.
- Lightly tug on the pipe to confirm the tabs have locked.

It is acceptable to use screws no longer than 1/2 in. (13 mm) to hold outer pipe sections together. If predrilling holes, **DO NOT** penetrate inner pipe.

For 90° and 45° elbows that are changing the vent direction

from horizontal to vertical, one screw minimum should be put in the outer flue at the horizontal elbow joint to prevent the elbow from rotating. Use screws no longer than 1/2 in. (13 mm). If predrilling screw holes, **DO NOT** penetrate inner pipe.



Figure 7.1 High Temperature Silicone Sealant

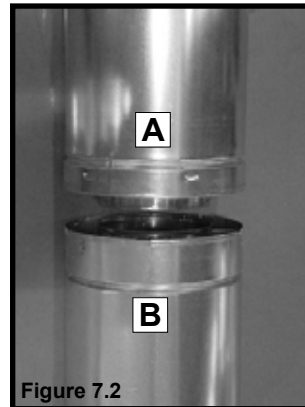

Figure 7.2

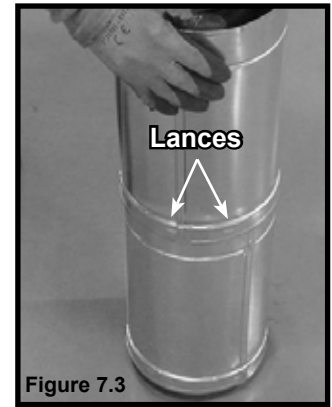
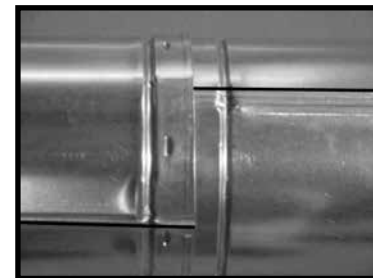
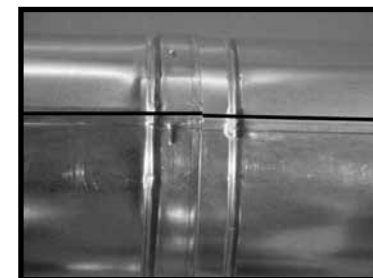

Figure 7.3

Note: Make sure that the seams are not aligned to prevent unintentional disconnection.



CORRECT



INCORRECT

Figure 7.4 Seams

B . Assemble Vent Sections

(SLP Only)

To attach the first vent component to the starting collars of the appliance:

- Attach a DVP-SLP24 adapter to the starting collar of the appliance.
- Lock the vent components into place by sliding the pipe section onto the collar.
- Align the seam of the pipe and seam of collar to allow engagement. Rotate the vent component to lock into place. Use this procedure for all vent components. See Figure 7.5.
- Slide the gasket over the first vent section and place it flush to the appliance. This will prevent cold air infiltration. Caulk with a minimum of 300 °F continuous exposure rating may be used to hold the part in place.
- Continue adding vent components, locking each succeeding component into place.
- Ensure that each succeeding vent component is securely fitted and locked into the preceding component.

It is acceptable to use screws no longer than 1/2 in. (13 mm) to hold outer pipe sections together. If predrilling holes, **DO NOT** penetrate inner pipe.

Required Commercial, Multi-family (Multi-level exceeding two stories), or High-Rise Applications

All outer pipe joints must be sealed with high temperature silicone (300 °F minimum continuous exposure rating), including the slip section that connects directly to the horizontal termination cap.

- Apply a bead of silicone sealant (300 °F minimum continuous exposure rating) inside the female outer pipe joint prior to joining sections. See Figure 7.1. **OR**

Apply a bead of silicone sealant (300 °F minimum continuous exposure rating) to the outside of connecting joint after joining sections **OR**

Apply aluminum foil tape (300 °F minimum continuous exposure rating) to the outside of connecting joint after joining sections. On horizontal pipe runs, it is recommended that the tape seam is positioned on the bottom side of the vent pipe.

- Only outer pipes need to be sealed. All unit collar, pipe, slip section, elbow and cap outer flues shall be sealed in this manner, unless otherwise stated.

WARNING! Risk of Fire or Explosion! DO NOT break silicone seals on slip sections. Use care when removing termination cap from slip pipe. If slip section seals are broken during removal of the termination cap, vent could leak.

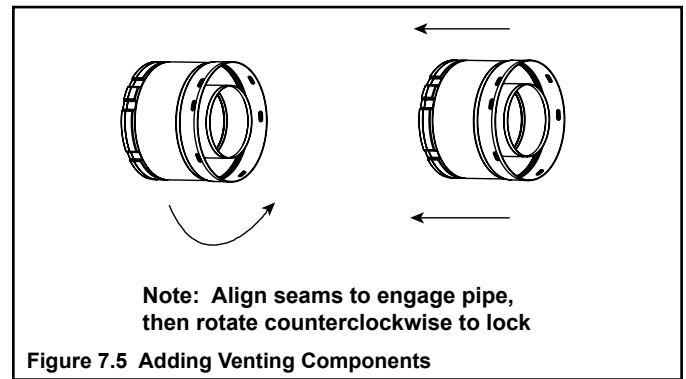

Figure 7.5 Adding Venting Components

C. Assemble Slip Sections

- Slide the inner flue of the slip section into the inner flue of the pipe section and the outer flue of the slip section over the outer flue of the pipe section. See Figure 7.6.
- Slide together to the desired length.

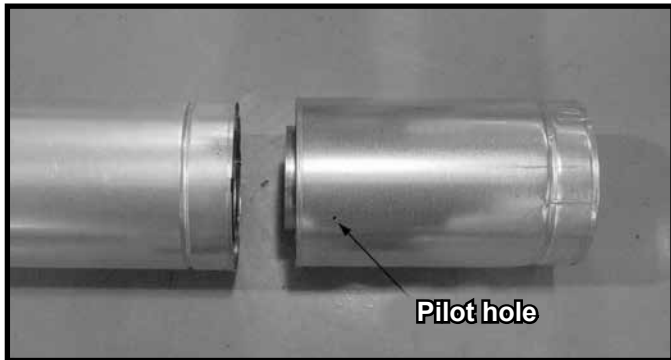

Figure 7.6 Slip Section Pilot Holes

- Maintain a 1-1/2 in. (38 mm) overlap between the slip section and the pipe section.
- Secure the pipe and slip section with two screws no longer than 1/2 in. (13 mm), using the pilot holes in the slip section. See Figure 7.7.

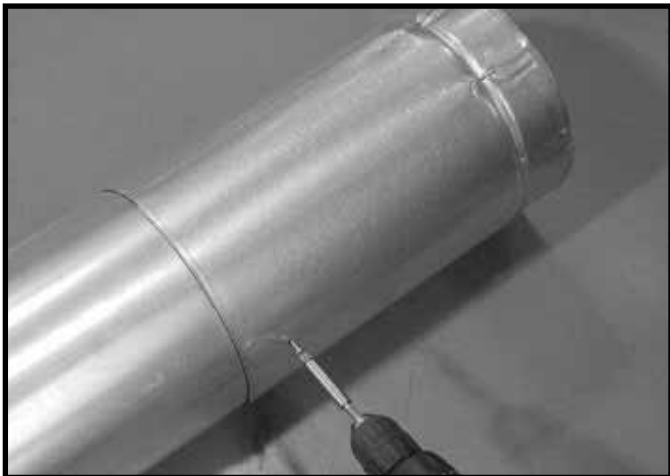

Figure 7.7 Screws into Slip Section

- Continue adding pipe as necessary following instructions in “Assembling Pipe Sections.”

NOTICE: If slip section is too long, the inner and outer flues of the slip section can be cut to the desired length.

NOTICE: When installing a vent system with an HRC termination cap, all pipe system joints shall be sealed using a high temperature silicone sealant (300 °F minimum continuous exposure rating).

- Apply a bead of silicone sealant (300 °F minimum continuous exposure rating) inside the female outer pipe joint prior to joining sections.
- Only outer pipes are sealed, sealing the inner flue is not required.
- All unit collar, pipe, slip section, elbow and cap outer flues shall be sealed.

D. Secure the Vent Sections

- Vertical runs originating off the top of the appliance, with no offsets, must be supported every 8 ft. (2.44 m) after the maximum allowed 25 ft. (7.62 m) of unsupported rise.
- Vertical runs originating off the rear of the appliance, or after any elbow, must be supported every 8 ft. (2.44 m).
- Horizontal runs must be supported every 5 feet (1.52 m).
- Vent supports or plumbers strap (spaced 120° apart) may be used to support vent sections. See Figures 7.8 and 7.9.
- Wall shield firestops may be used to provide horizontal support to vent sections.
- SLP ceiling firestops have tabs that may be used to provide vertical support.

WARNING! Risk of Fire, Explosion or Asphyxiation! Improper support could allow vent to sag and separate. Use vent run supports and connect vent sections per installation instructions. **DO NOT** allow vent to sag below connection point to appliance.

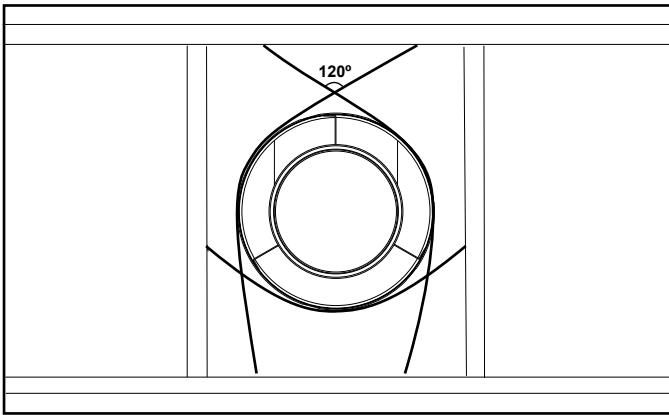

Figure 7.8 Securing Vertical Pipe Sections

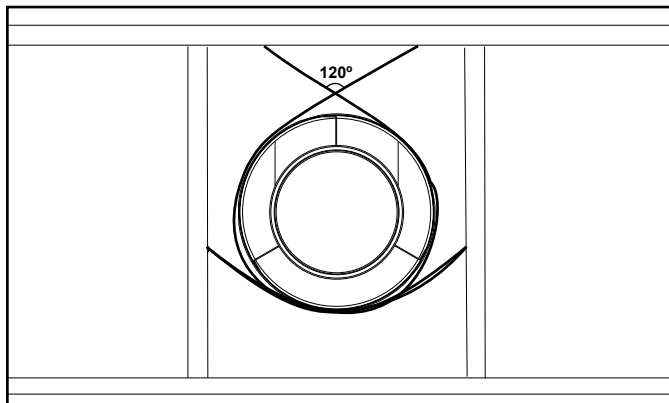

Figure 7.9 Securing Horizontal Pipe Sections

E. Disassemble Vent Sections

- Rotate either section (see Figure 7.10) so the seams on both pipe sections are aligned as shown in Figure 7.11.
- Pull carefully to separate the pieces of pipe.

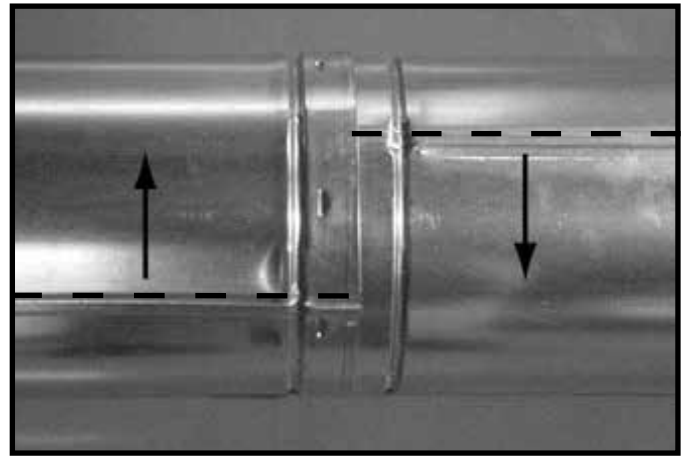

Figure 7.10 Rotate Seams for Disassembly

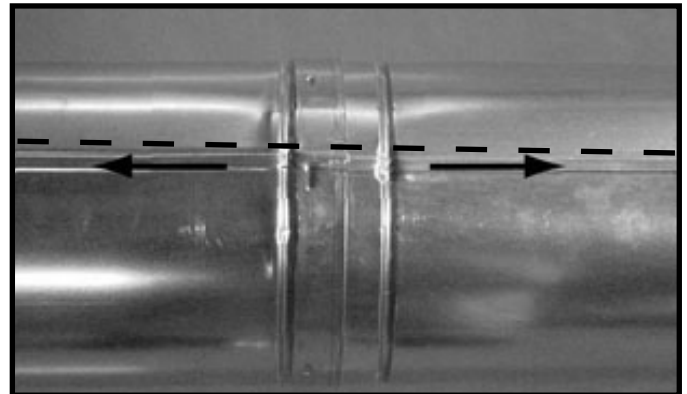

Figure 7.11 Align and Disassemble Vent Sections

F. Vertical Termination Requirements

Install Metal Roof Flashing

- See minimum vent heights for various pitched roofs (Figure 7.12) to determine the length of pipe to extend through the roof.
- Slide the roof flashing over the pipe sections extending through the roof as shown in Figure 7.13.

Note: When installing a silicone or EPDM pipe flashing boot on a metal roof, it is recommended to put a bead of 100% silicone sealant where the boot contacts the vent pipe to prevent the entry of water. Follow the manufacturer's recommendations when installing the boot. Climate regions with frequent temperatures below - 50 °F (-45.6 °C) should use a silicone flashing boot.

NOTICE: Failure to properly caulk the roof flashing and pipe seams could permit entry of water.

- Caulk the gap between the roof flashing and the outside diameter of the pipe.
- Caulk the perimeter of the flashing where it contacts the roof surface. See Figure 7.13.
- Caulk the overlap seam of any exposed pipe sections that are located above the roof line.

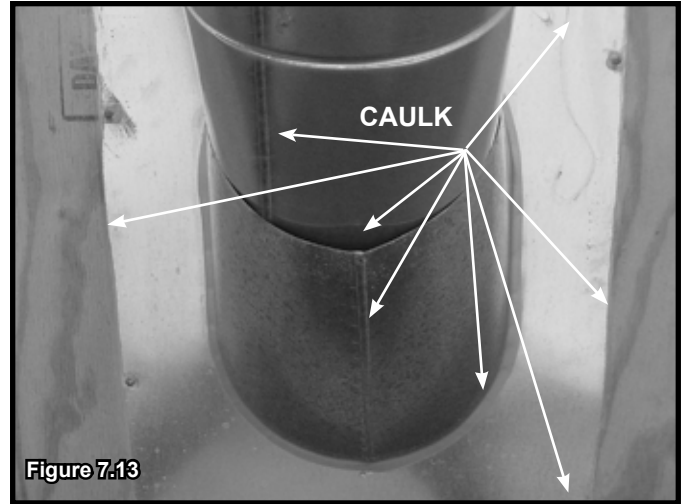
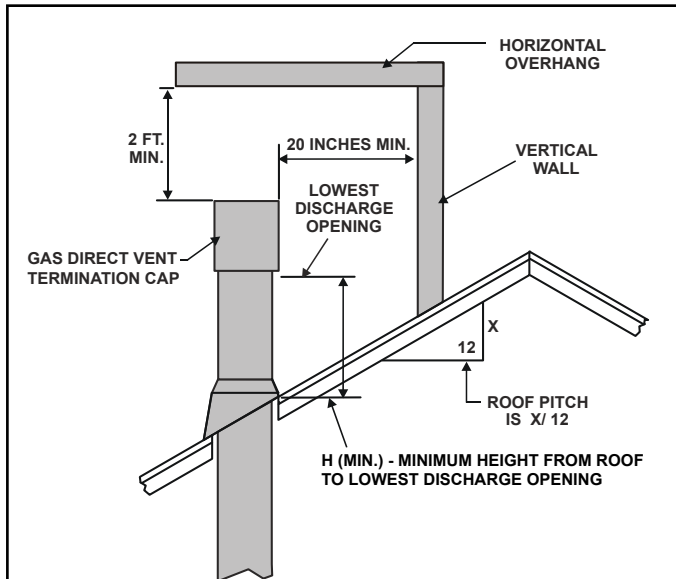

Figure 7.13



Roof Pitch	H (Min.) Ft.
Flat to 6/12.....	1.0*
Over 6/12 to 7/12.....	1.25*
Over 7/12 to 8/12.....	1.5*
Over 8/12 to 9/12.....	2.0*
Over 9/12 to 10/12.....	2.5*
Over 10/12 to 11/12.....	3.25
Over 11/12 to 12/12.....	4.0
Over 12/12 to 14/12.....	5.0
Over 14/12 to 16/12.....	6.0
Over 16/12 to 18/12.....	7.0
Over 18/12 to 20/12.....	7.5
Over 20/12 to 21/12.....	8.0

* H minimum may vary depending on regional snowfall. Refer to local codes.

Figure 7.12 Minimum Height From Roof to Lowest Discharge Opening

Assemble and Install Storm Collar

CAUTION! Risk of Cuts, Abrasions or Flying Debris. Wear protective gloves and safety glasses during installation. Sheet metal edges are sharp.

- Slide the storm collar onto the exposed pipe section and align brackets.
- Insert a bolt (provided) through the brackets and install nut. Do not completely tighten.



- Slide the assembled storm collar down the pipe section until it rests on the roof flashing (see Figure 7.14).
- Tighten nut and make sure the collar is tight against the pipe section.
- Caulk around the top of the storm collar. See Figure 7.15.

Install Vertical Termination Cap

- Attach the vertical termination cap by sliding the inner collar of the cap into the inner flue of the pipe section while placing the outer collar of the cap over the outer flue of the pipe section.
- Secure the cap by driving three self-tapping screws (supplied) through the pilot holes in the outer collar of the cap into the outer flue of the pipe (see Figure 7.15).

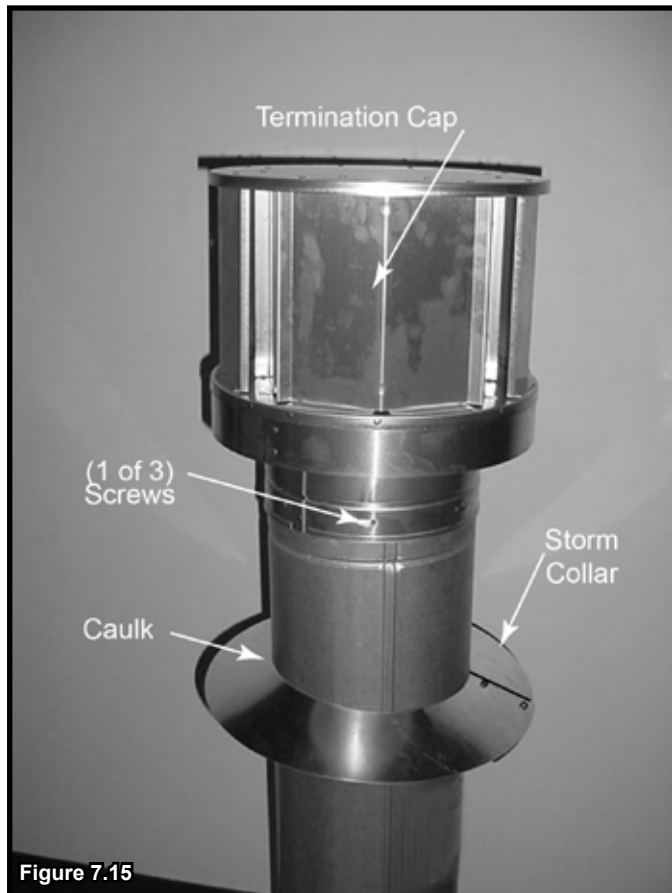

Figure 7.15

G. Horizontal Termination Requirements

Heat Shield Requirements for Horizontal Termination

WARNING! Risk of Fire! To prevent overheating and fire, heat shields must extend through the entire wall thickness.

- **DO NOT** remove the heat shields attached to the wall shield firestop and the horizontal termination cap (shown in Figure 7.16).
- Heat shields must overlap 1-1/2 in. (38 mm) minimum.

There are two sections of the heat shield. One section is factory-attached to the wall shield firestop. The other section is factory-attached to the cap. See Figure 7.16.

If the wall thickness does not allow the required 1-1/2 in. (38 mm) heat shield overlap when installed, an extended heat shield must be used.

- If the wall thickness is less than 4 in./102 mm (DVP) or 4-3/8 in./ 111 mm (SLP), the heat shields on the cap and wall shield firestop must be trimmed. A minimum 1-1/2 in. (38 mm) overlap **MUST** be maintained.
- Use an extended heat shield if the finished wall thickness is greater than 7-1/4 in. (184 mm).
- The extended heat shield may need to be cut to length maintaining sufficient length for a 1-1/2 in. (38 mm) overlap between heat shields.
- Attach the extended heat shield to either of the existing heat shields using the screws supplied with the extended heat shield. Refer to vent components diagrams in the back of this manual.
- Rest the small leg on the extended heat shield on top of the pipe section to properly space it from the pipe section.

Important Notice: Heat shields may not be field constructed.

Install Horizontal Termination Cap (DVP and SLP Pipe)

WARNING! Risk of Fire! The telescoping flue section of the termination cap **MUST** be used when connecting vent.

- 1-1/2 (38 mm) minimum overlap of flue telescoping section is required.

Failure to maintain overlap could cause overheating and fire.

- Vent termination must not be recessed in the wall. Siding may be brought to the edge of the cap base.
- Flash and seal as appropriate for siding material at outside edges of cap.
- When installing a horizontal termination cap, follow the cap location guidelines as prescribed by current **ANSI Z223.1** and **CAN/CGA-B149** installation codes and refer to Section 4 of this manual.

CAUTION! Risk of Burns! Local codes may require installation of a cap shield to prevent anything or anyone from touching the hot cap.

NOTICE: For certain exposures which require superior resistance to wind-driven rain penetration, a flashing kit and HRC caps are available. When penetrating a brick wall, a brick extension kit is available for framing the brick.

Note: When using termination caps with factory-supplied heat shield attached, no additional wall shield firestop is required on the exterior side of a combustible wall.

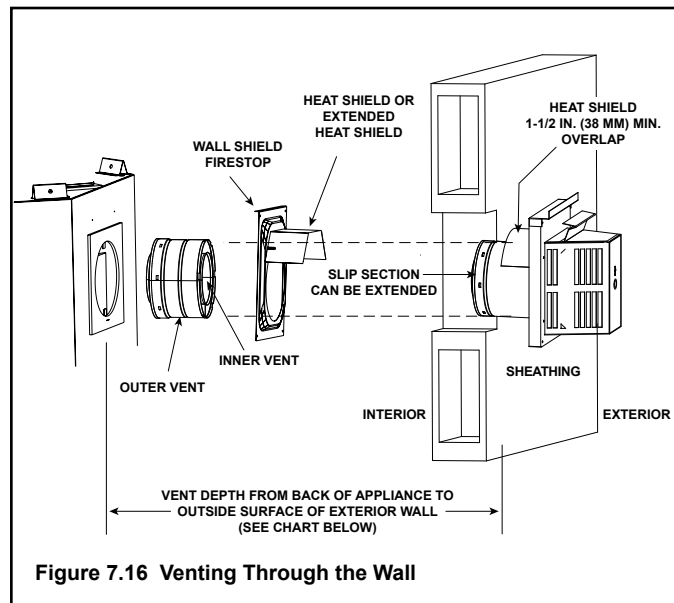

Figure 7.16 Venting Through the Wall

Cap Specification Chart
(depth without using additional pipe sections)

CD4236 CD4842 Series	DVP-TRAPK1 Top Vent <u>Depth</u>	DVP-TRAP1 Rear Vent <u>Depth</u>	DVP-TRAPK2 Top Vent <u>Depth</u>	DVP-TRAP2 Rear Vent <u>Depth</u>
	2-3/4 in. to 4-5/8 in.	3-1/8 in. to 5 in.	5-1/8 in. to 9-1/8 in.	5-1/2 in. to 9-1/2 in.
	DVP-HPC1 Top Vent <u>Depth</u>	DVP-HPC1 Rear Vent <u>Depth</u>	DVP-HPC2 Top Vent <u>Depth</u>	DVP-HPC2 Rear Vent <u>Depth</u>
	2-3/4 in. to 4-7/8 in.	3-1/8 in. to 5-1/4 in.	4-7/8 in. to 9 in.	5-1/4 in. to 9-3/8 in.

DVP-TRAP1 can adjust 1-1/2 in. (3-1/8 to 4-5/8 in.)

DVP-TRAP2 can adjust 4 in. (5-3/8 to 9-3/8)

DVP-HPC1 can adjust 2-1/8 in. (4-1/4 to 6-3/8)

DVP-HPC2 can adjust 4-1/8 in. (6-3/8 to 10-1/2)

8 Electrical Information

A. General Information

WARNING! Risk of Shock or Explosion! DO NOT wire 110-120 VAC to the valve or to the appliance wall switch. Incorrect wiring will damage controls.

NOTICE: This appliance must be electrically wired and grounded in accordance with local codes or, in the absence of local codes, with **National Electric Code ANSI/NFPA 70-latest edition** or the **Canadian Electric Code CSA C22.1**.

- Wire the appliance junction box to unswitched 110-120 VAC. This is required for proper operation of the appliance.
- A 110-120 VAC circuit for this product must be protected with ground-fault circuit-interrupter protection, in compliance with the applicable electrical codes, when it is installed in locations such as in bathrooms or near sinks.
- Low voltage and 110-120 VAC voltage cannot be shared within the same wall box.
- In some instances, the spark ignition of the fireplace may cause intermittent, non-damaging, interference during the lighting sequence with a TV plugged into the same circuit. It is recommended that the fireplace and TV use different circuits to mitigate the interference potential. If interference is occurring on the same circuit, the use of surge protectors may help alleviate the interference.

Junction Box Installation

If the box is being wired from the **INSIDE** of the appliance:

- Remove the screw attaching the junction box/receptacle to the outer shell, rotate the junction box inward to disengage it from the outer shell. See Figure 8.1.
- Pull the electrical wires from outside the appliance through the opening into the valve compartment and secure wires with a Romex connector. See Figure 8.1.
- Make all necessary wire connections to the junction box/receptacle and reattach the junction box/receptacle to the outer shell.

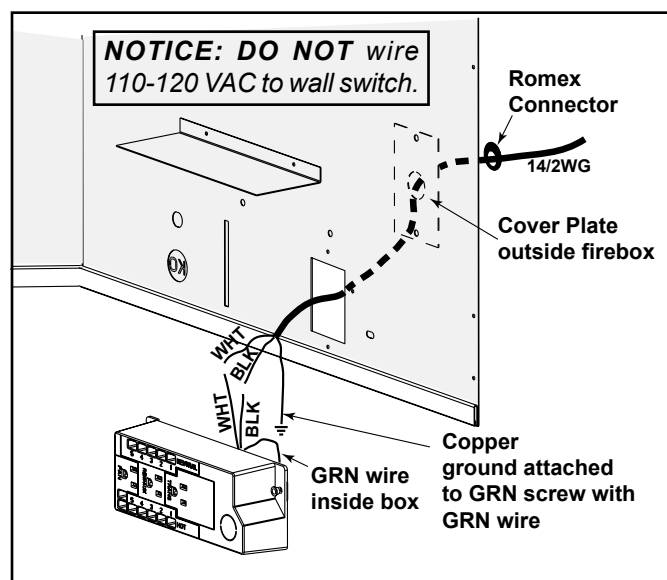

Figure 8.1 Junction Box Detail

Accessories Requirements

- This appliance may be used with a wall switch, wall mounted thermostat and/or a remote control.

Wiring for optional Hearth & Home Technologies approved accessories should be done now to avoid reconstruction. Follow instructions that come with those accessories.

Electrical Service and Repair

WARNING! Risk of Shock! Label all wires prior to disconnection when servicing controls. Wiring errors could cause improper and dangerous operation. Verify proper operation after servicing.

WARNING! Risk of Shock! Replace damaged wire with type 105° C rated wire. Wire must have high temperature insulation.

B. Wiring Requirements

IntelliFire Touch® Ignition System Wiring

- Wire the appliance junction box to 110-120 VAC for proper operation of the appliance.

WARNING! Risk of Shock or Explosion! DO NOT wire IPI controlled appliance junction box to a switched circuit. Incorrect wiring will override IPI safety lockout.

- Refer to Figure 8.2 IntelliFire Touch (IPI) Wiring Diagram.
- This appliance is equipped with an IntelliFire® control valve which operates on a 6 volt system.

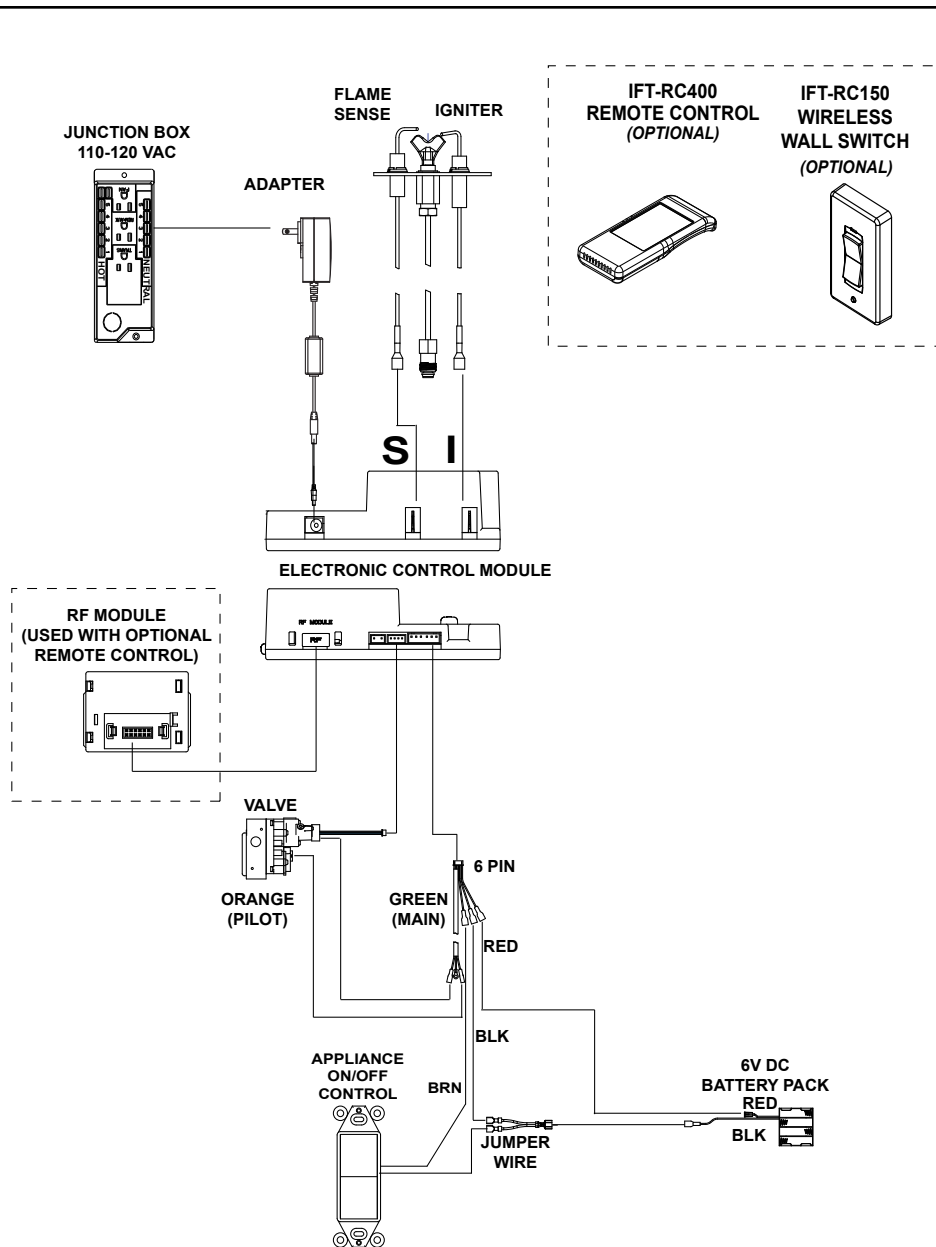
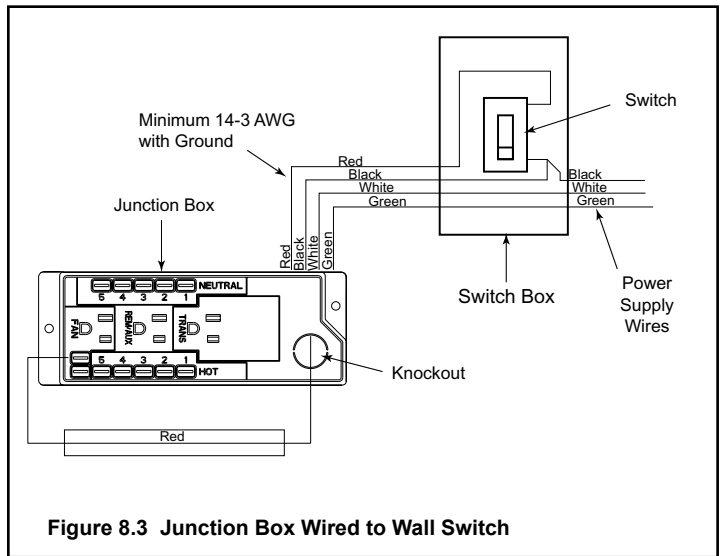

Figure 8.2 IntelliFire Touch Pilot Ignition Wiring Diagram

Wall Switch Installation for Fan (Optional)

If the box is being wired to a wall mounted switch for use with a fan. See Figure 8.3:

- The power supply for the appliance must be brought into a switch box.
- The power can then be supplied from the switch box to the appliance using a minimum of 14-3 with ground wire.
- At the switch box connect the black (hot) wire and red (switch leg) wire to the wall switch as shown.
- At the appliance connect the black (hot), white (neutral) and green (ground) wires to the junction box as shown.
- Add a 1/4 in. insulated female connector to the red (switch leg) wire, route it through the knockout in the face of the junction box, and connect to the top fan switch connector (1/4 in. male) as shown.



9 Gas Information

A. Fuel Conversion

- Make sure the appliance is compatible with available gas types.
- Conversions must be made by a qualified service technician using Hearth & Home Technologies specified and approved parts.



B. Gas Pressure

- Optimum appliance performance requires proper input pressures.
- Gas line sizing requirements will be determined in ANSI Z223.1 National Fuel Gas Code in the USA and CAN/CGA B149 in Canada.
- Pressure requirements are:

Gas Pressure	Natural Gas	Propane
Minimum inlet pressure	5.0 in. w.c.	11.0 in. w.c.
Maximum inlet pressure	10.0 in. w.c.	13.0 in. w.c.
Manifold pressure	3.5 in. w.c.	10.0 in. w.c.

WARNING! Risk of Fire or Explosion! High pressure will damage valve. Low pressure could cause explosion.

- Verify inlet pressures. Verify minimum pressures when other household gas appliances are operating.
- Install regulator upstream of valve if line pressure is greater than 1/2 psig.

 WARNING	
 	<p>Fire Risk. Explosion Hazard. High pressure will damage valve.</p> <ul style="list-style-type: none">• Disconnect gas supply piping BEFORE pressure testing gas line at test pressures above 1/2 psig.• Close the manual shutoff valve BEFORE pressure testing gas line at test pressures equal to or less than 1/2 psig.

Note: Have the gas supply line installed in accordance with local codes, if any. If not, follow ANSI Z223.1. Installation should be done by a qualified installer approved and/or licensed as required by the locality. (In the Commonwealth of Massachusetts installation must be performed by a licensed plumber or gas fitter).

Note: A listed (and Commonwealth of Massachusetts approved) 1/2 in. (13 mm) T-handle manual shut-off valve and flexible gas connector are connected to the 1/2 in. (13 mm) control valve inlet.

- **If substituting for these components, please consult local codes for compliance.**

C. Gas Connection

- Refer to Section 3 for location of gas line access in appliance.
- Gas line may be run through knockout(s) provided.
- The gap between supply piping and gas access hole may be caulked with caulk with a minimum of 300 °F continuous exposure rating or stuffed with non-combustible, unfaced insulation to prevent cold air infiltration.
- Ensure that gas line does not come in contact with outer wrap of the appliance. Follow local codes.
- Pipe incoming gas line into valve compartment.
- Connect incoming gas line to the 1/2 in. (13 mm) connection on manual shutoff valve.

WARNING! Risk of Fire or Explosion! Support control when attaching pipe to prevent bending gas line.

- A small amount of air will be in the gas supply lines.

WARNING! Risk of Fire or Explosion! Gas build-up during line purge could ignite.

- Purge should be performed by qualified service technician.
- Ensure adequate ventilation.
- Ensure there are no ignition sources such as sparks or open flames.

Light the appliance. It will take a short time for air to purge from lines. When purging is complete the appliance will light and operate normally.

WARNING! Risk of Fire, Explosion or Asphyxiation! Check all fittings and connections with a non-corrosive commercially available leak-check solution. **DO NOT** use open flame. Fittings and connections could have loosened during shipping and handling.

WARNING! Risk of Fire! DO NOT change valve settings. This valve has been preset at the factory.

D. High Altitude Installations

NOTICE: If the heating value of the gas has been reduced, these rules do not apply. Check with your local gas utility or authorities having jurisdiction.

When installing above 2000 feet elevation:

- In the USA: Reduce input rate 4% for each 1000 feet above 2000 feet.
- In CANADA: Input ratings are certified without a reduction of input rate for elevations up to 4500 feet (1370 m) above sea level. Please consult provincial and/or local authorities having jurisdiction for installations at elevations above 4500 feet (1370 m).

Check with your local gas utility to determine proper orifice size.

E. Air Shutter Setting

Air shutter settings should be adjusted by a qualified service technician at the time of installation. The air shutter is set at the factory for minimum vertical vent run. Adjust air shutter for longer vertical runs. See Figure 9.1.

- Loosen the wing nut.
- Move the air handle to the right to open the air shutter.
- Move the air handle to the left to close the air shutter.
- Tighten the wing nut.

NOTICE: If sooting occurs, provide more air by opening the air shutter.

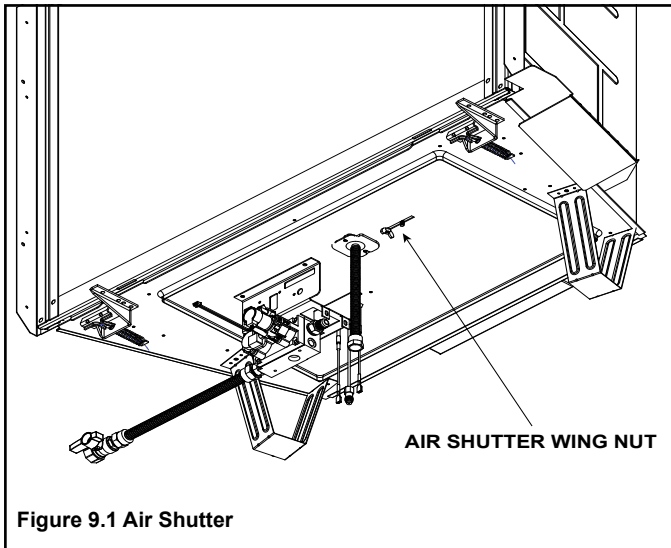

Air Shutter Settings

	NG	Propane
CD4236IFTR CD4236IFTLR	1/8 in.	5/8 in.
CD4842IFTR CD4842IFTLR	5/16 in.	Fully Open

10 Finishing

A. Facing Material

- Metal front faces may be covered with non-combustible materials only.
- Facing and/or finishing materials must not interfere with air flow through or removal of decorative fronts or access for service.
- Facing and/or finishing materials must never overhang into the glass opening.
- Observe all clearances when applying combustible materials.
- Seal joints between the finished wall and appliance top and sides using a 300 °F minimum sealant. Refer to Figure 10.1.

WARNING! Risk of Fire! DO NOT apply combustible materials beyond the minimum clearances. Comply with all minimum clearances to combustibles as specified in this manual. Overlapping materials could ignite and will interfere with air flow through decorative fronts.

NOTICE: Surface temperatures around the appliance will become warm while the appliance is in operation. Ensure finishing materials used for all surfaces (floor, walls, mantels, etc.) will withstand temperatures up to 190°F.

Finish wall material may be combustible - Top and Sides
 Seal Top and Side Joints with High Temperature Sealant (300 °F/149 °C min.)

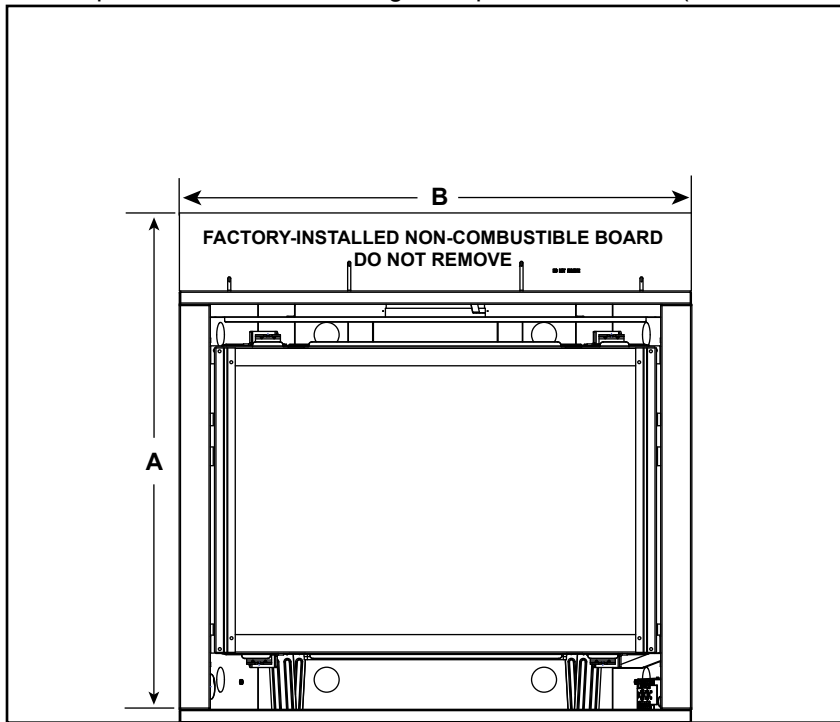

		A	B
CD4236	inches	39-3/4	41
	millimeters	1010	1041
CD4842	inches	41-3/4	48
	millimeters	1060	1219

Figure 10.1 Noncombustible Facing Diagram

B. Mantel and Wall Projections

WARNING! Risk of Fire! Comply with all minimum clearances as specified. Framing closer than the minimums listed must be constructed entirely of noncombustible materials (i.e., steel studs, concrete board, etc.)

Note: Measurement is taken from top of the opening, NOT the top of the fireplace.

Mantels - Combustible or Painted Surfaces

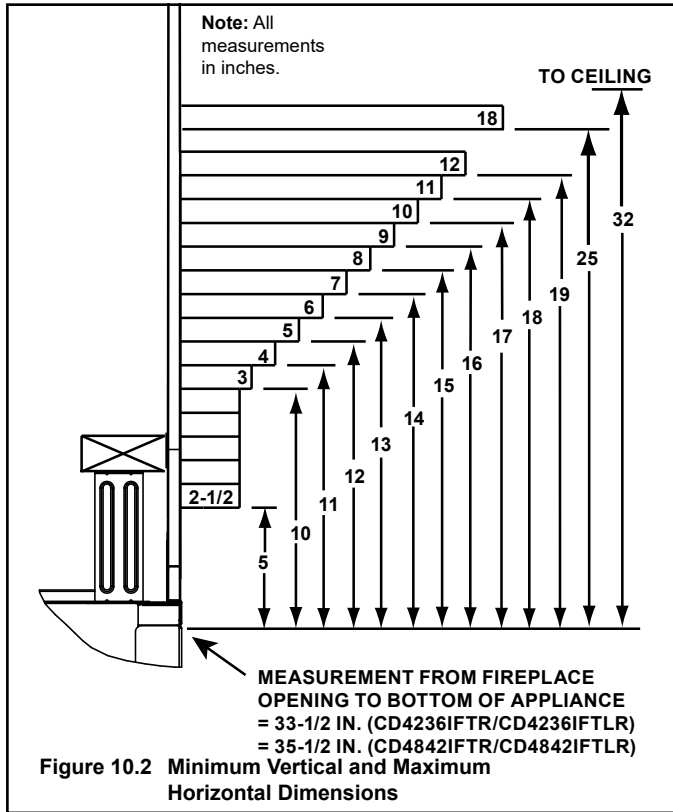

Combustible Mantel Legs or Wall Projections

Mantels - Non-Combustible

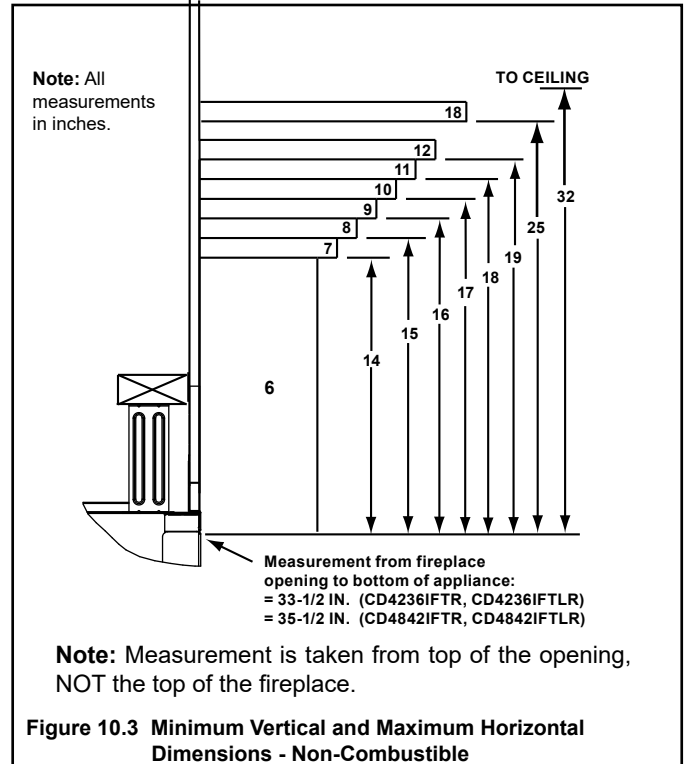

Mantel Legs or Wall Projections

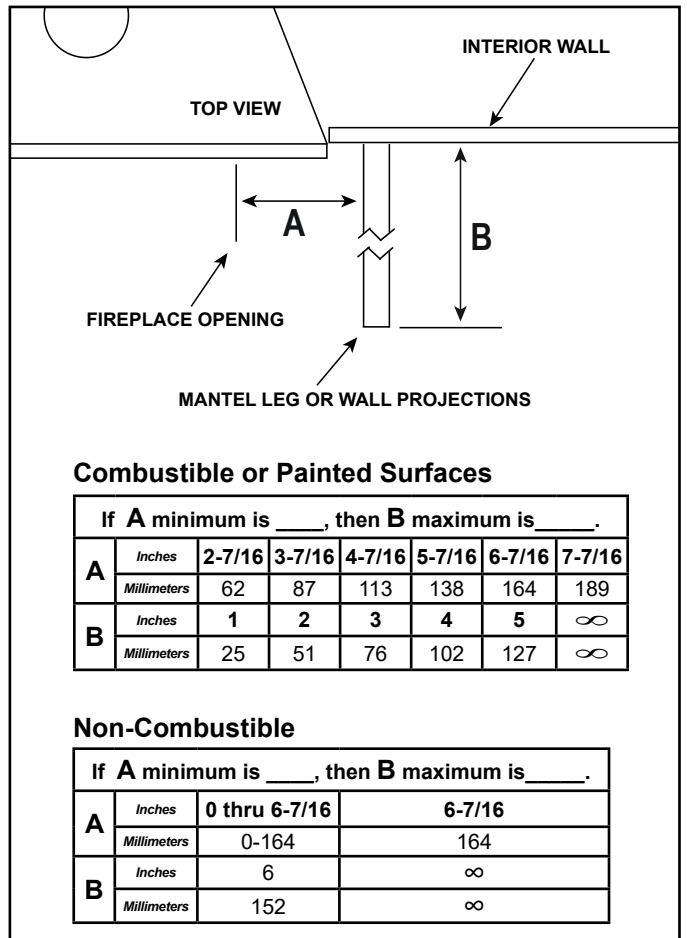
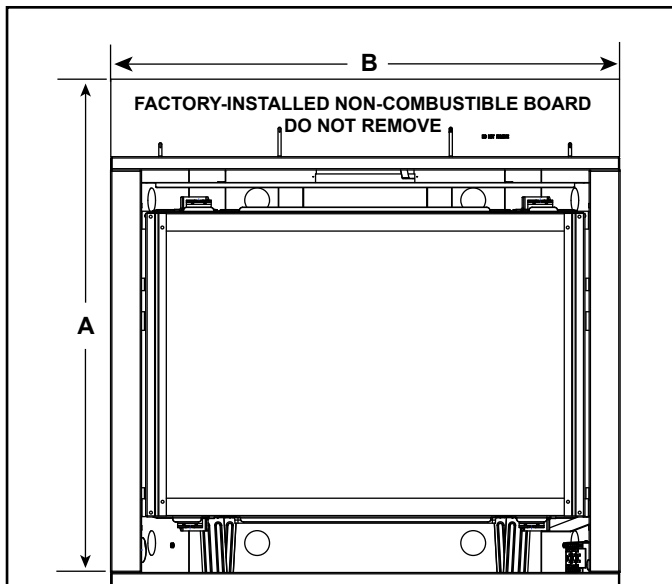

Figure 10.4 Clearances to Mantel Leg or Wall Projections (Acceptable on both sides of opening)

C. Facing Material

- Metal front faces may be covered with non-combustible materials only.
- Facing and/or finishing materials must not interfere with air flow through decorative fronts, removal of decorative fronts or access for service.
- Facing and/or finishing materials must never overhang into the glass opening.
- Observe all clearances when applying combustible materials.
- Seal joints between the finished wall and appliance top and sides using a 300 °F minimum sealant. Refer to Figure 10.5.

WARNING! Risk of Fire! DO NOT apply combustible materials beyond the minimum clearances. Comply with all minimum clearances to combustibles as specified in this manual. Overlapping materials could ignite and will interfere with proper operation of decorative fronts.



		A	B
CD4236IFTR CD4236IFTLR	inches	39-3/4	41
	millimeters	1010	1041
CD4842IFTR CD4842IFTLR	inches	41-3/4	48
	millimeters	1060	1219

Figure 10.5 Noncombustible Facing Diagram

D. Decorative Fronts

Only decorative fronts certified for use with this appliance model may be used. Contact your dealer for a list of decorative fronts that may be used. Once you have determined what kind of decorative front and finishing material is going to be used on the fireplace, you may use the table below which shows the decorative front models and the finishing material thickness allowed.

DECORATIVE FRONT	FIT	FINISH MATERIAL THICKNESS	SEE FIGURE
Simon	Inside	0-6 Inches max.	10.7
Contour	Overlap	1 inch or less	10.5
	Inside	1-6 inches max.	10.6
Craftsman	Inside	0-6 Inches max.	10.7

Finishing Material: 1 Inch Thick or Less(Overlap Fit)

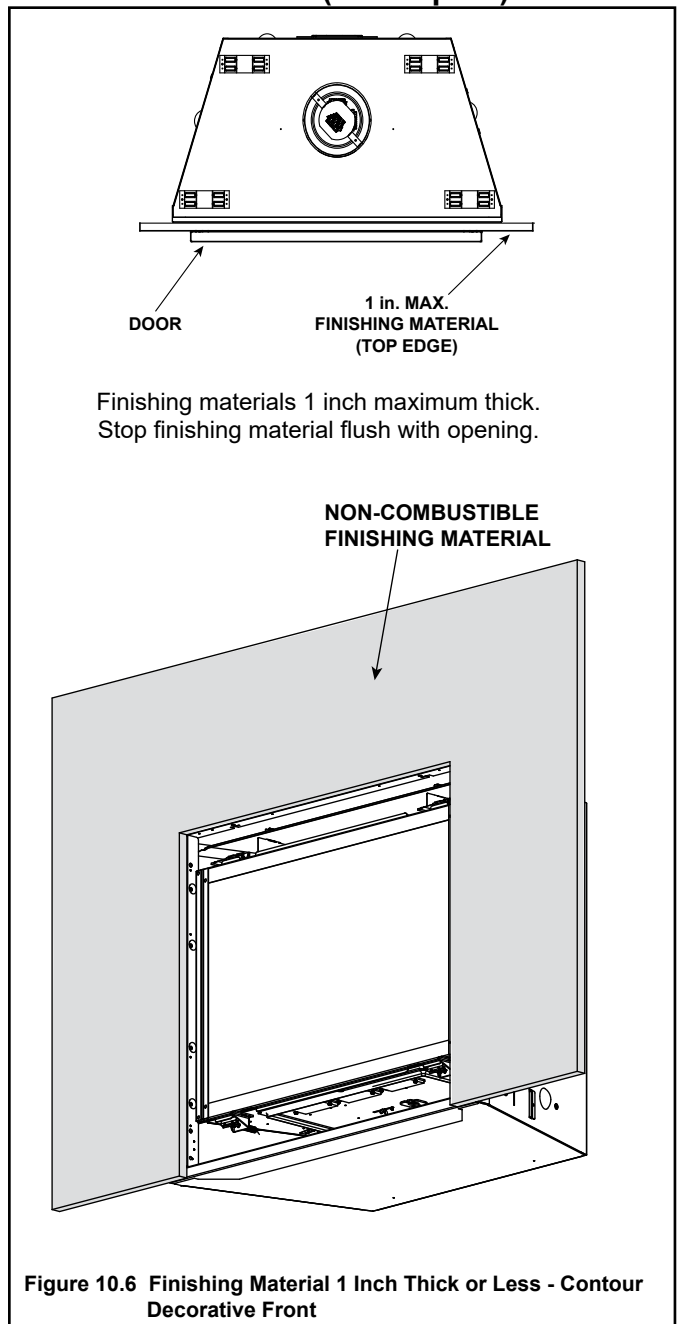
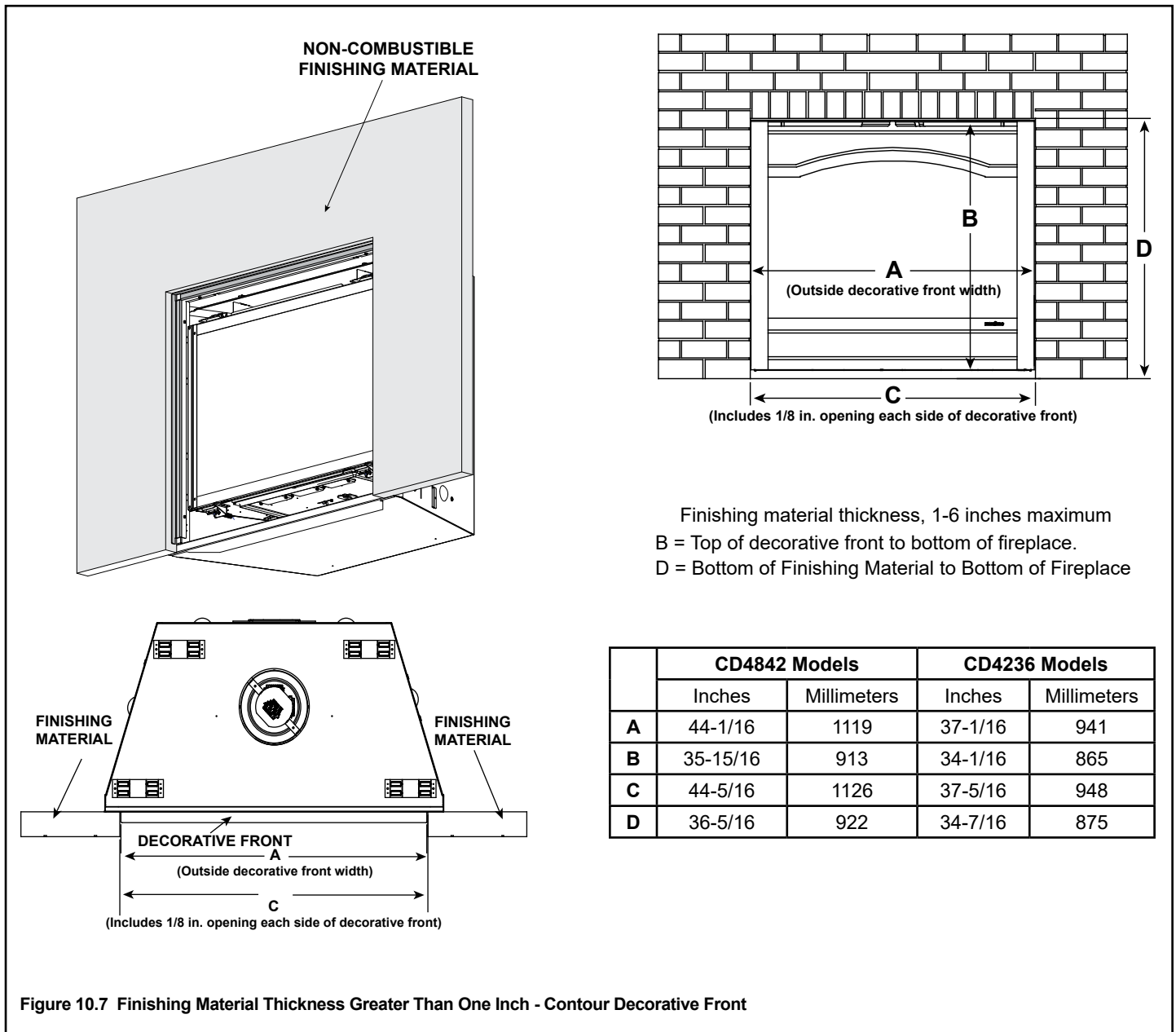

Figure 10.6 Finishing Material 1 Inch Thick or Less - Contour Decorative Front

**Finishing Material Thickness:
1-6 Inches Maximum
(Inside Fit)**



**Finishing Material Thickness:
0-6 Inches Maximum
(Inside Fit)**

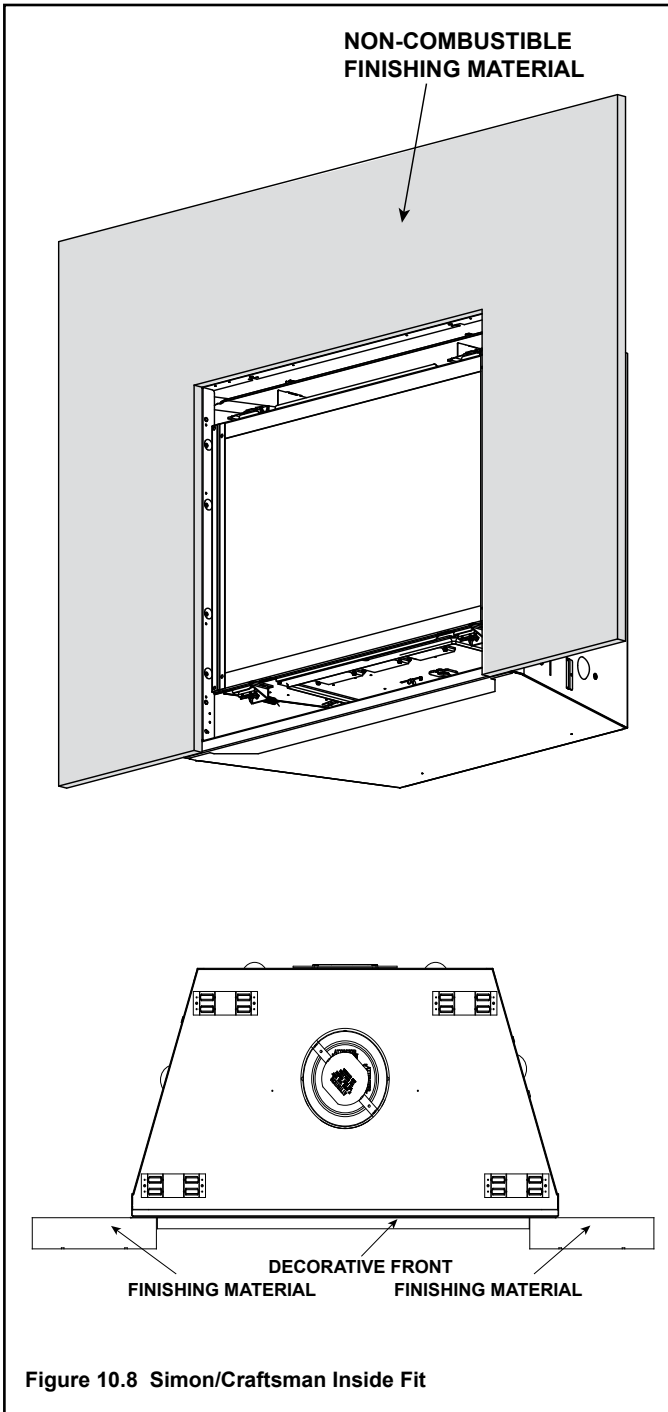

Figure 10.8 Simon/Craftsman Inside Fit

11 Appliance Setup

A. Remove Fixed Glass Assembly

WARNING! Risk of Asphyxiation! Handle fixed glass assembly with care. Inspect the gasket to ensure it is undamaged and inspect the glass for cracks, chips or scratches.

- **DO NOT** strike, slam or scratch glass.
- **DO NOT** operate fireplace with glass removed, cracked, broken or scratched.
- Replace as a complete assembly.
- Pull the four glass assembly latches out of the groove on the glass frame. Remove glass assembly from the appliance. See Figure 11.1.

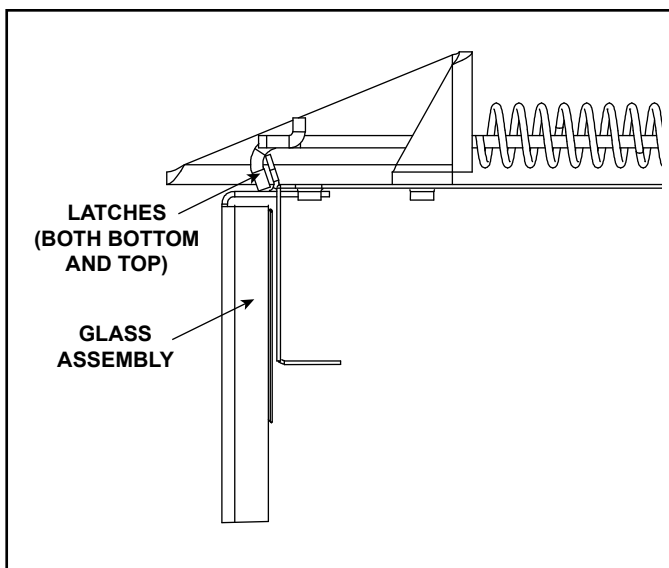

Figure 11.1 Fixed Glass Assembly

B. Remove the Shipping Materials

Remove shipping materials from inside or underneath the firebox.

- The splatter guard is a piece of corrugated material used to protect the appliance during the installation process before finishing work on the whole hearth is complete. Splatter guards may be factory installed or accompany the decorative front of the appliance, depending on the fireplace model. Splatter guards must be removed before appliance is fired.

WARNING! Risk of Fire! Close the ball valve before installing the splatter guard to prevent accidental lighting. Remove the splatter guard before lighting the appliance.

C. Clean the Appliance

Clean/vacuum any sawdust that may have accumulated inside the firebox or underneath in the control cavity.

D. Install the Refractory (Optional)

Optional fiber and black glass refractory kits are available with these models. Install either the black glass refractory or brick refractory per instructions included with the kit.

E. Ember Placement

WARNING! Risk of Explosion! Follow ember placement instructions. DO NOT place ember directly over burner ports. Replace ember material annually. Improperly placed ember material interferes with proper burner operation.

Place the Ember Material

See Figures 11.2 and 11.3. Place a small amount of 1/2 in. diameter pieces (dime-size) of ember material on the burner top. Be careful not to cover burner ports. It is not necessary to use the entire bag. Save the remaining amount for future use.

WARNING! Risk of Explosion! Follow ember placement instructions. DO NOT place embers directly over burner ports. Replace ember material annually. Improperly placed embers interfere with proper burner operation.

Ember material is shipped with this gas appliance. To place the ember material:

- Embers CANNOT be placed directly over ports. Care should be taken not to cover the lighting trail of ports (from back to front).
- Place dime-size pieces of Glowing Embers® just in front of the port trail, but not on or in between the ports. See Figure 11.3. Care should be taken so that the ports are not covered. Failure to follow this procedure will likely cause lighting and sooting problems.



Figure 11.2 Placement of Embers

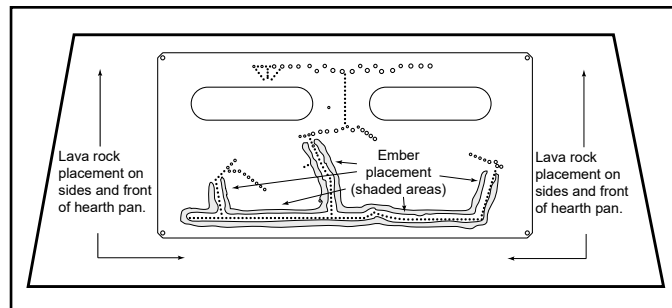

Figure 11.3 Placement of Embers

F. Place the Lava Rock

See Figures 11.3 and 11.4. Lava rock should be evenly spread on firebox bottom. It is not necessary to use the entire bag. Save the remaining amount for future use.



Figure 11.4 Placement of Lava Rock

G. Install the Log Assembly

LOG PLACEMENT INSTRUCTIONS

Log Set Assembly: LOGS-4236, LOGS-4842

Models: CNXT4236IT-C/D, CNXT4842IT-C/D, CNXT4236IH-C/D, CNXT4842IH-C/D,
CNXT4236IFTT/H, CNXT4842IFTT/H, CD4236IR-C/D, CD4842IR-C/D
CD4236IFTR, CD4236IFTLR, CD4842IFTR, CD4842IFTLR

CAUTION: Logs are fragile, handle with care.

Log A: SRV2208-702

Log B: SRV2208-703

Log C: SRV2208-704

Log D: SRV2208-073 (4236 models)
SRV2211-073 (4842 models)

Log E: SRV2208-705

Log F: SRV2208-706

1. Base logs B, C and D have been permanently mounted on the grate assembly. Do not attempt to remove or relocate the logs.
2. Log A placement (SRV2208-702): Install Log A as shown in Figure 2 and Figure 3. Locate log placement bracket and placement tabs shown in Figure 2. Align holes in bottom of log with alignment tabs. Place log down on log placement bracket and push back toward the rear of the firebox. See Figure 3.

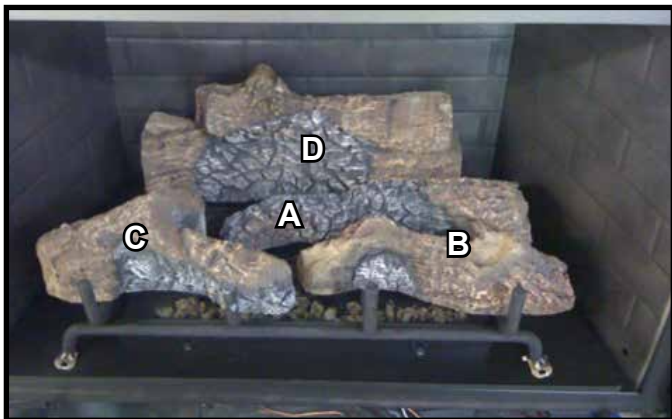

Figure 1. Base Logs

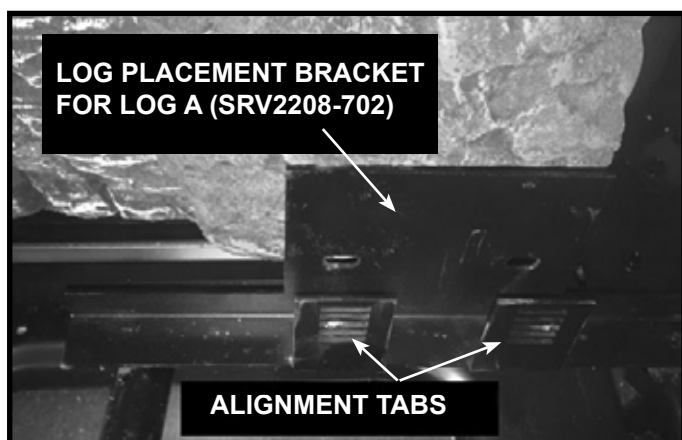

Figure 2.



Figure 3.

3. Left log placement (SRV2208-705) : Mate rear and front faces of left log with indentations on rear and base logs as shown in Figure 4 and Figure 5. Slide the left log back.
4. Right log placement (SRV2208-706) : Place the right log by positioning the front “V” of the log on the indentation on the base log and resting the rear of the log on the flat area of the rear log. See Figure 4 and Figure 6.
5. Figure 6 shows the left and right logs properly placed. Both left and right logs should sit securely on the rear and corresponding base logs.

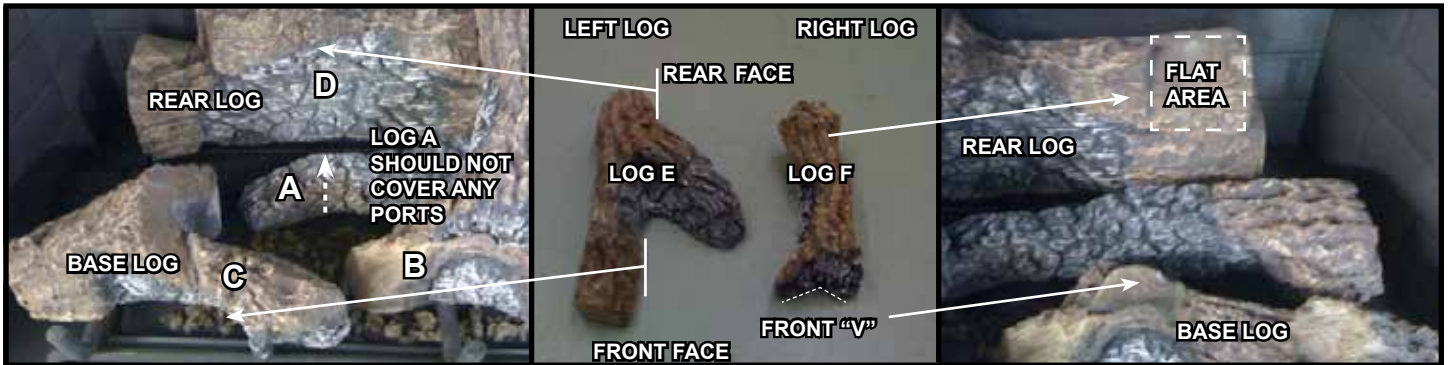

Figure 4. Left Log and Right Log Reference Points



Figure 5. Left Log in Proper Position



Figure 6. Left and Right Log in Proper Position

H. IntelliFire Touch® Control System Setup

- Detailed instructions for electrical wiring and connections are provided in Section 8.
- Determine if this appliance is equipped with a Module Reset Switch. See Section 8. Verify this switch is in the ON position.
- Verify that the 3-Position switch on the IFT-ECM is switched to the REMOTE position. Detailed Operating Instructions for the IFT-ECM are provided in Section 3.J of the Owner's Manual.

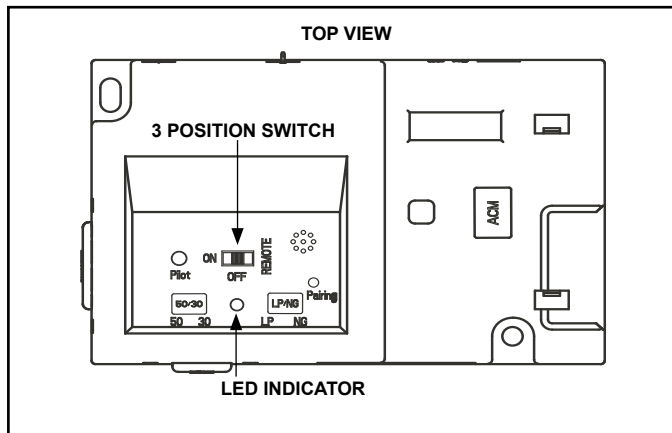

Figure 11.5 IFT-ECM

If this appliance is being upgraded to an optional IntelliFire Touch Remote Control, and/or optional power vent, fan, or light kit are added as new accessory upgrade(s) to fireplace:

1. The RC400 remote will need to be paired to the ECM.
2. Follow the installation instructions provided with the IntelliFire Touch remote and/or accessory kit(s).

I. Install Fixed Glass Assembly

WARNING! Risk of Asphyxiation! Handle fixed glass assembly with care. Inspect the gasket to ensure it is undamaged and inspect the glass for cracks, chips or scratches.

- **DO NOT** strike, slam or scratch glass.
- **DO NOT** operate fireplace with glass removed, cracked, broken or scratched.
- Replace as a complete assembly.

Replace the glass assembly on the appliance. Pull out and latch the four glass assembly latches into the groove on the glass frame.

J. Fiber Refractory Color Review

(Optional Fiber Refractory Only):

Based on the installation of the appliance, the lighting may cause the back refractory panel to appear lighter than the side panels. In these rare cases, the recommended solution is to use the tested and approved aerosol touchup paint (TUP-GBK-12) to fog the back panels to match the side panels.

12 Reference Materials

A. Vent Components Diagrams

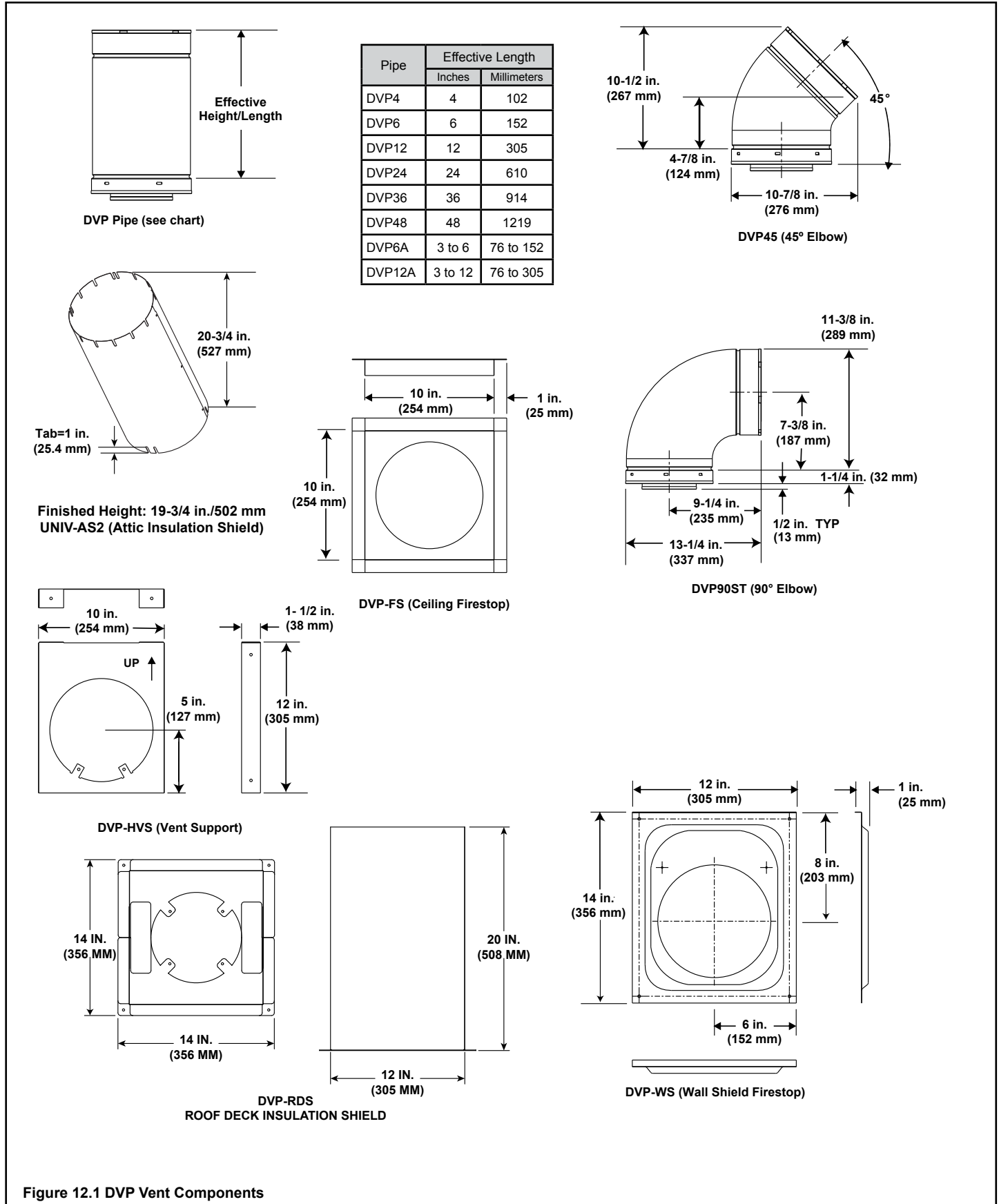
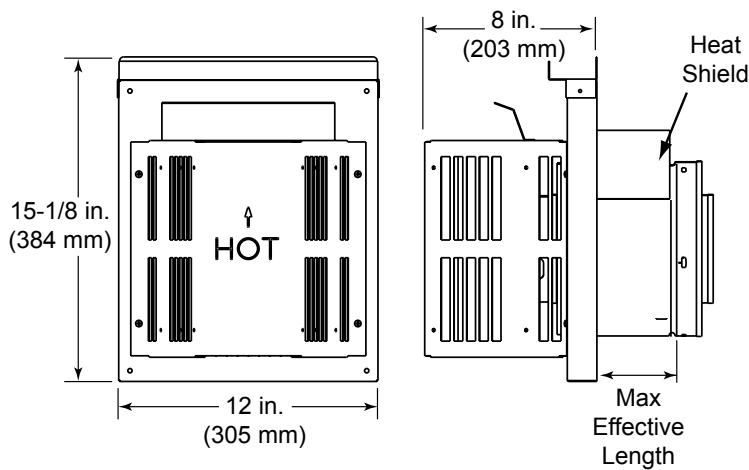

Figure 12.1 DVP Vent Components

A. Vent Components Diagrams (continued)

Note: Heat shields MUST overlap by a minimum of 1-1/2 in. (38 mm). The heat shield is designed to be used on a wall 4 in. to 7-1/4 in. (102 mm to 184 mm) thick. If wall thickness is less than 4 in. (102 mm) the existing heat shields must be field trimmed. If wall thickness is greater than 7-1/4 in. (184 mm) a DVP-HSM-B will be required.



DVP-TRAP
Horizontal Termination Cap

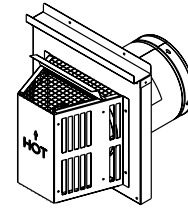

Term Cap	Minimum Effective Length	Maximum Effective Length
Trap1	3-1/8 in.	4-5/8 in.
	79 mm	117 mm
Trap2	5-3/8 in.	9-3/8 in.
	137 mm	238 mm

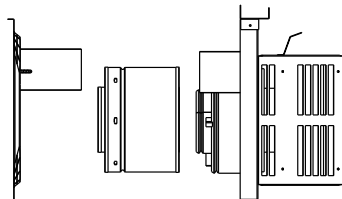

DVP-TRAP1

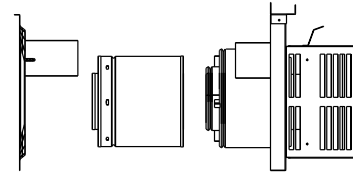

DVP-TRAP2

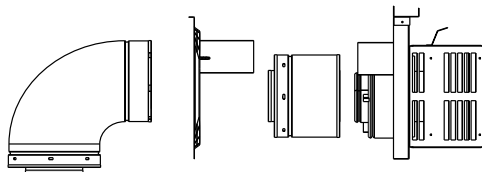

DVP-TRAPK1

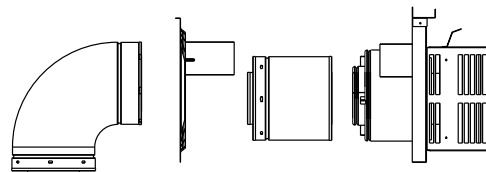

DVP-TRAPK2

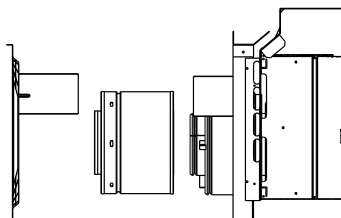

DVP-HPC1

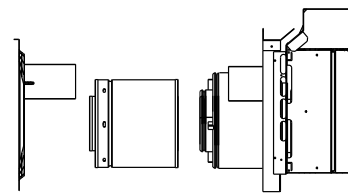

DVP-HPC2

Figure 12.2 DVP Vent Components

A. Vent Components Diagrams (continued)

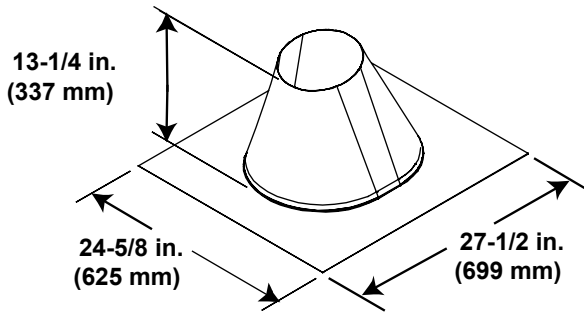

**RF6
Roof Flashing**

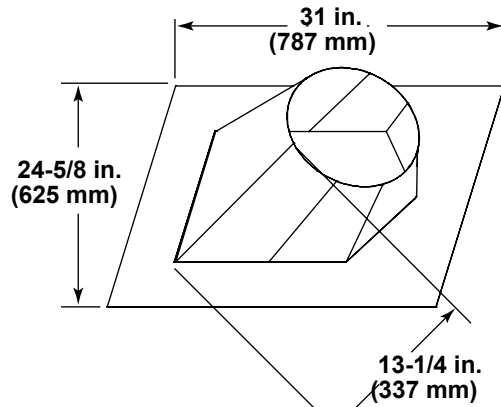

**RF12
Roof Flashing**

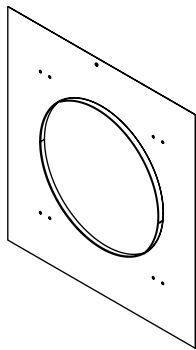

**DVP-TRAPFL
Flashing**

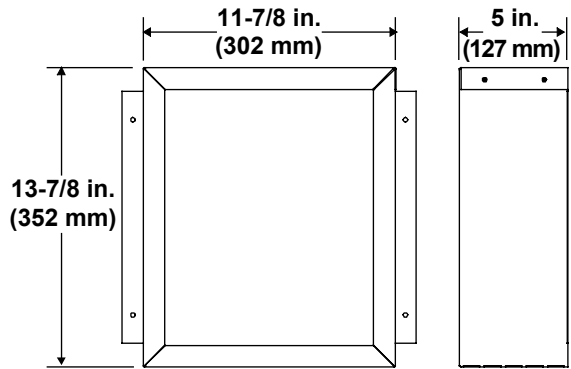

**DVP-BEK2
DVP-HPC Cap Brick Extension**

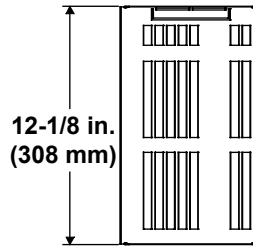
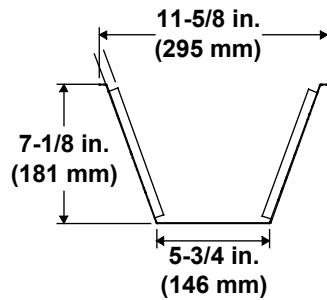

**COOL-ADDM
Cap Shield**

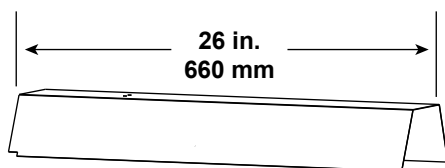
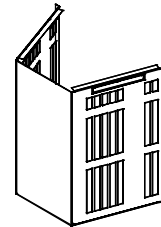

**DVP-HSM-B
Extended Heat Shield**

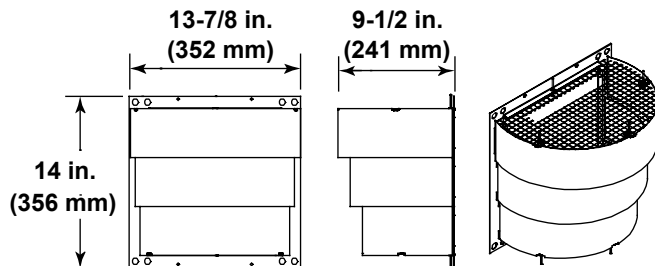

**DRC-RADIUS
Cap Shield**

Figure 12.3 DVP Vent Components

A. Vent Components Diagrams (continued)

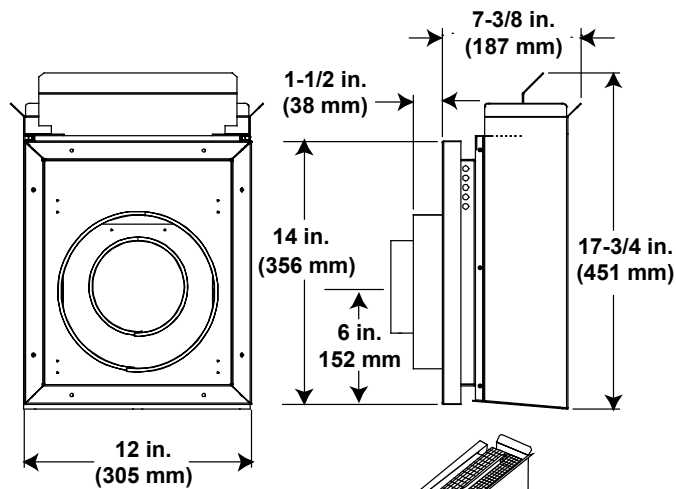

DVP-TB1
Basement Vent Cap

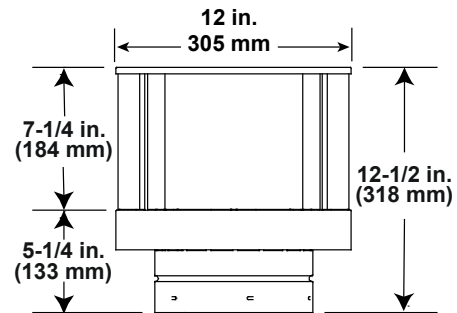

DVP-TVHW
Vertical Termination Cap (Highwind)

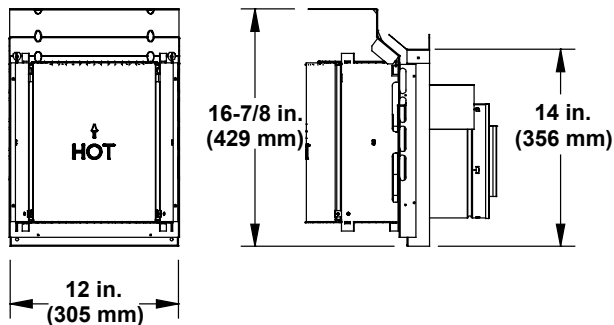

DVP-HPC
High Performance Cap

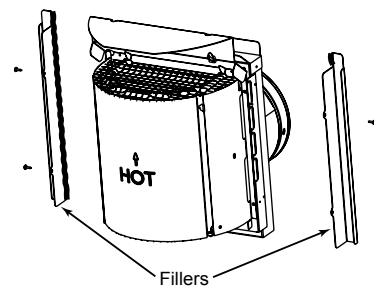
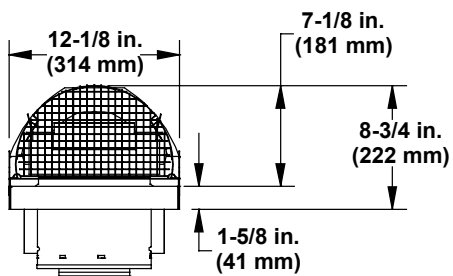

DVP-TRAP to DVP-HPC Side Filler Kit

Figure 12.4 DVP Vent Components

A. Vent Components Diagrams (continued)

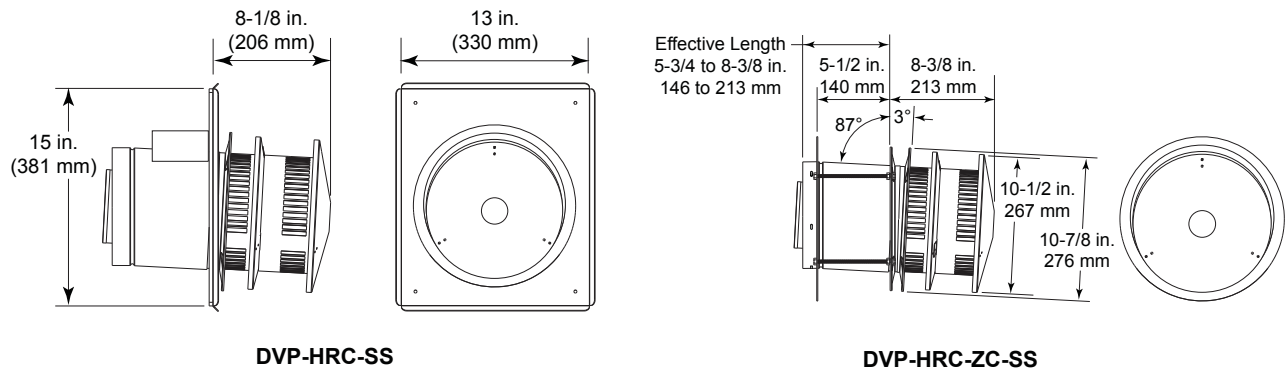

DECORATIVE TERMINATIONS/SHROUDS

Only use listed decorative termination caps/shrouds with Hearth & Home Technologies approved venting systems.

This applies to both DVP and SLP venting systems.

Decorative Terminations Caps/Shrouds

DTO134
DTO146
DTS134
DTS146
LDS33
LDS46
LDS-BV

Figure 12.5 DVP Vent Components

A. Vent Components Diagrams (continued)

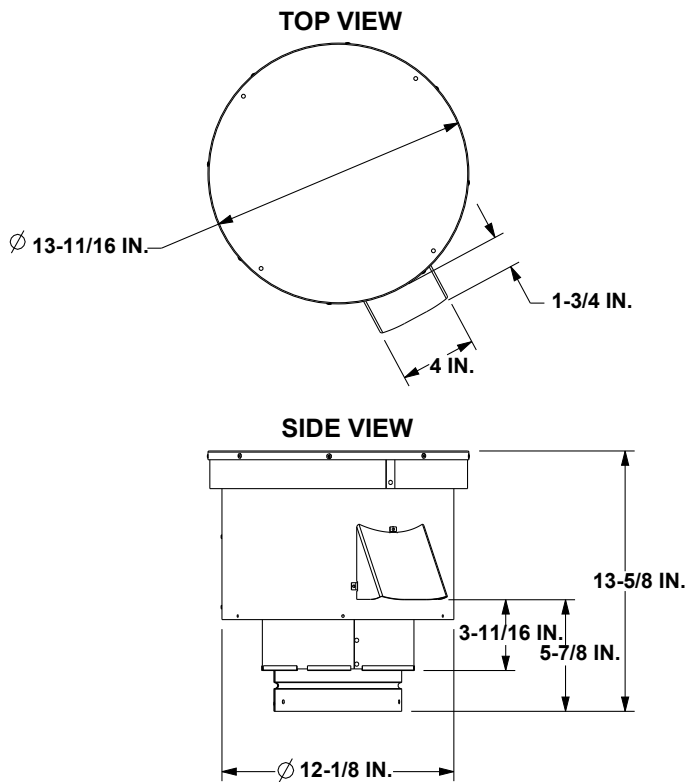

PVV-SLP
Vertical Power Vent

Required Wire Harness and PVV-SLEEVE	
Lengths Available	Part Number
10 ft. PV Wire Harness	PVI-WH10
20 ft. PV Wire Harness	PVI-WH20
40 ft. PV Wire Harness	PVI-WH40
60 ft. PV Wire Harness	PVI-WH60
80 ft. PV Wire Harness	PVI-WH80
100 ft. PV Wire Harness	PVI-WH100
Description	Part Number
12 in. Wire Harness Sleeve	PVV-SLEEVE-12
48 in. Wire Harness Sleeve	PVV-SLEEVE-48

Note: A wire harness is required to power the PVV-SLP and connect it to the appliance. It is ordered separately from the PVV-SLP. Contact your dealer to order.

Note: The PVV-SLEEVE-12 and/or PVV-SLEEVE-48 is required to be installed with the PVV-SLP. It is ordered separately from the PVV-SLP. Contact your dealer to order.

Note: The PVV-SLP requires one of the following options to be installed on this appliance.

Option A: IFT-RC400 and/or IFT-WFM, IFT-ACM and IntelliFire App that can be downloaded from the app store.

OR

Option B: IFT-RC150, IFT-ACM, IFT-WFM and an IntelliFire App that can be downloaded from the app store. These accessories are purchased separately from the PVV-SLP. Contact your dealer to order.

Figure 12.6 PVV-SLP Vent Components

A. Vent Components Diagrams (continued)

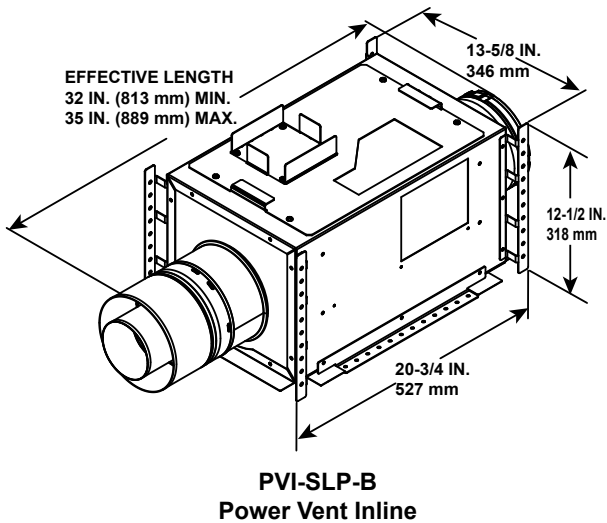

Optional Wire Harness	
DESCRIPTION	PART NUMBER
10 FT PV Wire Harness	PVI-WH10
20 FT PV Wire Harness	PVI-WH20
40 FT PV Wire Harness	PVI-WH40
60 FT PV Wire Harness	PVI-WH60
80 FT PV Wire Harness	PVI-WH80
100 FT PV Wire Harness	PVI-WH100

Note: Wire harnesses required to power the PVI-SLP-B connect to the appliance and are ordered separately from PVI-SLP-B. Contact your dealer to order.

Note: The PVI-SLP-B requires one of the following options to be installed on this appliance.

Option A: IFT-RC400 **OR**

Option B: IFT-RC150 and IFT-ACM.

These accessories are purchased separately from the PVI-SLP-B. Contact your dealer to order.

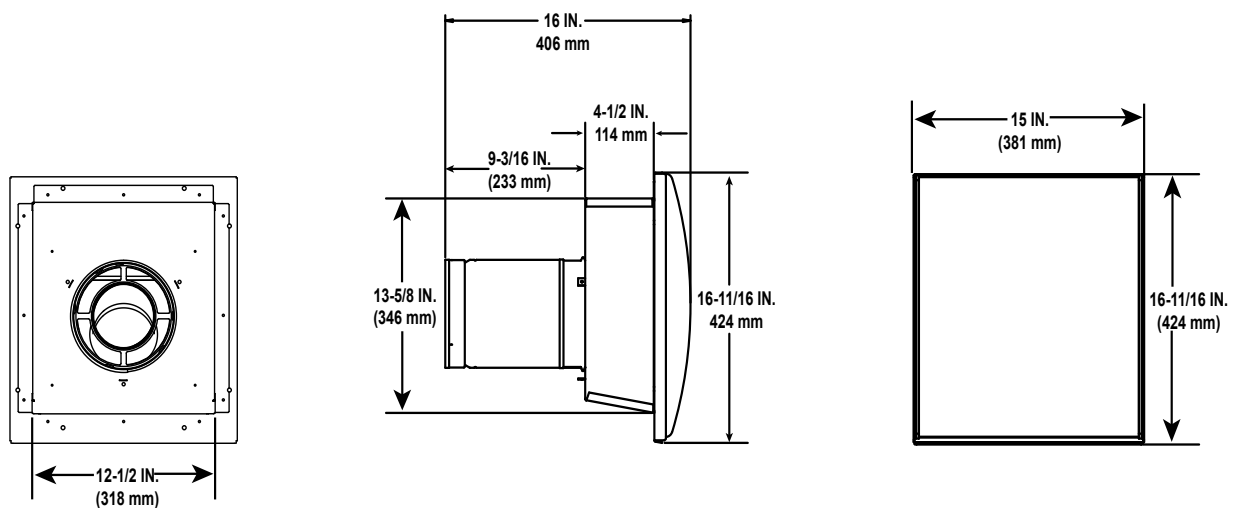

**SLP-LPC
SLP Low Profile Cap
(Approved for use with PVI-SLP-B only)**

Figure 12.7 PVI-SLP-B Vent Components

A. Vent Components Diagrams (continued)

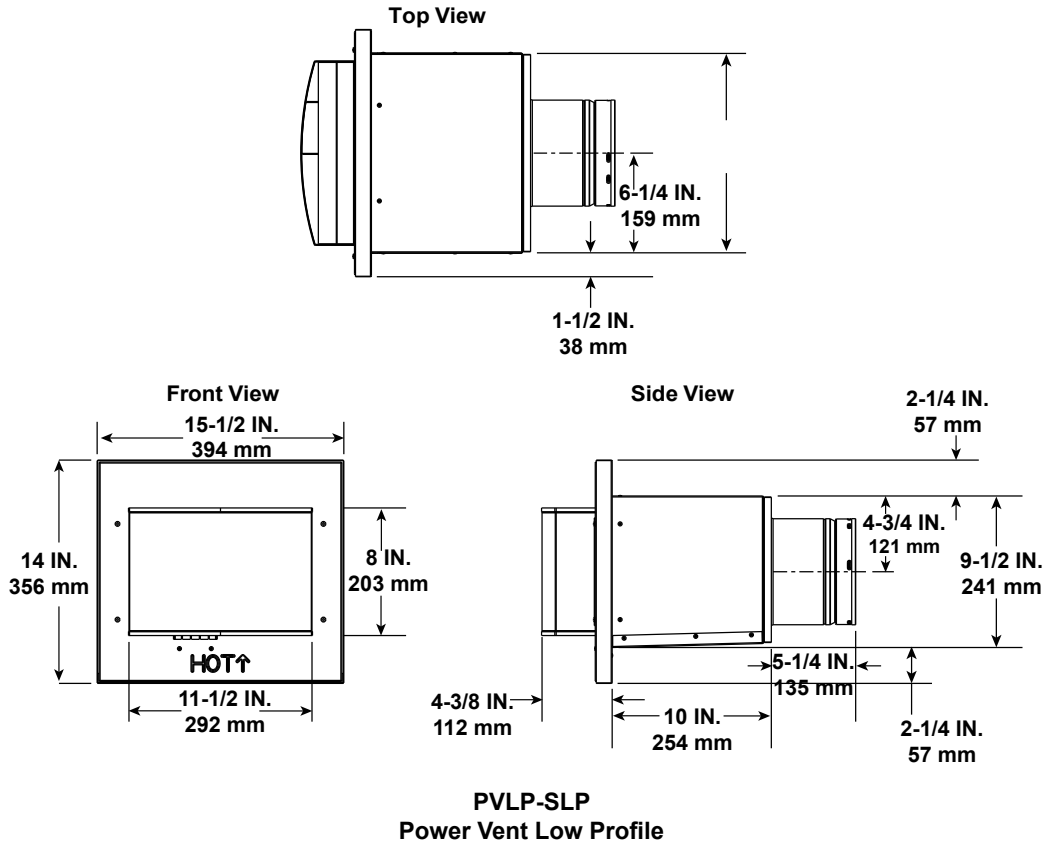

Note: Wire harnesses required to power the PVLP-SLP connect to the appliance and are ordered separately from PVLP-SLP. Contact your dealer to order.

Note: A PVLP-HS heat shield is available and sold separately. Use if the PVLP-SLP is installed in a high traffic area.

Note: The PVLP-SLP requires one of the following options to be installed on this appliance.

Option A: IFT-RC400 **OR**

Option B: IFT-RC150 and IFT-ACM

These accessories are purchased separately from the PVLP-SLP. Contact your dealer to order.

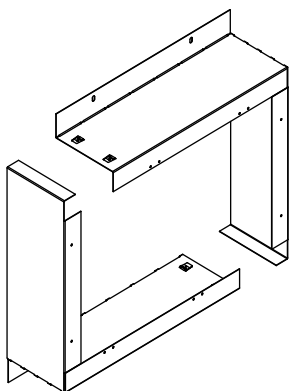

**PVLP-BEK
Brick Kit**

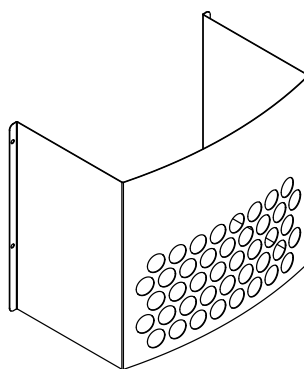

**PVLP-HS
Heat Shield**

Required Wire Harness	
DESCRIPTION	PART NUMBER
10 FT PV Wire Harness	PVI-WH10
20 FT PV Wire Harness	PVI-WH20
40 FT PV Wire Harness	PVI-WH40
60 FT PV Wire Harness	PVI-WH60
80 FT PV Wire Harness	PVI-WH80
100 FT PV Wire Harness	PVI-WH100

Figure 12.8 PVLP-SLP Vent Components

A. Vent Components Diagrams (continued)

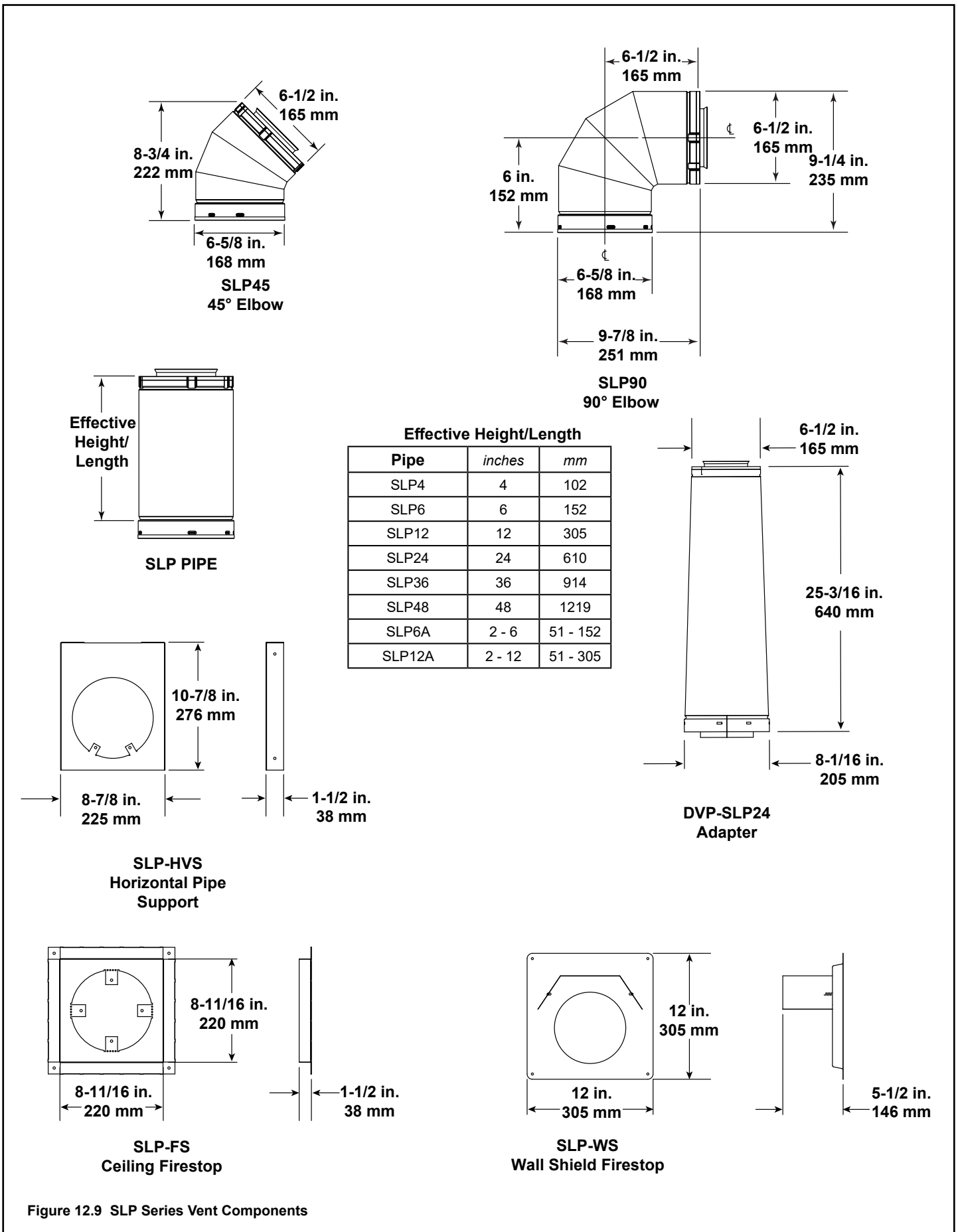
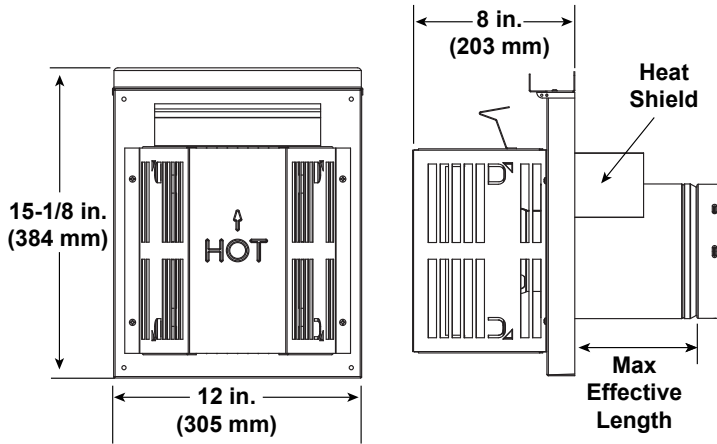

Figure 12.9 SLP Series Vent Components

A. Vent Components Diagrams (continued)

Note: Heat shields MUST overlap by a minimum of 1-1/2 in. (38 mm). The heat shield is designed to be used on a wall 4 in. to 7-1/4 in. (102 mm to 184 mm) thick. If wall thickness is less than 4 in. (102 mm) the existing heat shields must be field trimmed. If wall thickness is greater than 7-1/4 in. (184 mm) a DVP-HSM-B will be required.



SLP-TRAP
Horizontal Termination Cap

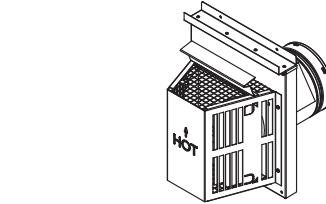

Term Cap	Minimum Effective Length	Maximum Effective Length
Trap1	3-1/8 in.	4-3/4 in.
	79 mm	121 mm
Trap2	5-1/4 in.	9-1/4 in.
	133 mm	235 mm

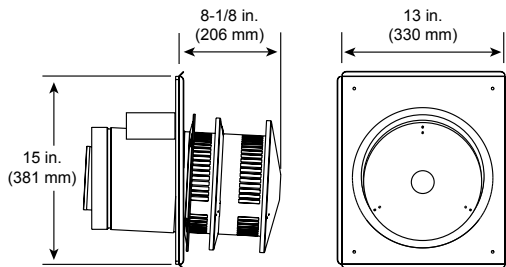

SLP-HRC-SS
Horizontal Termination Cap

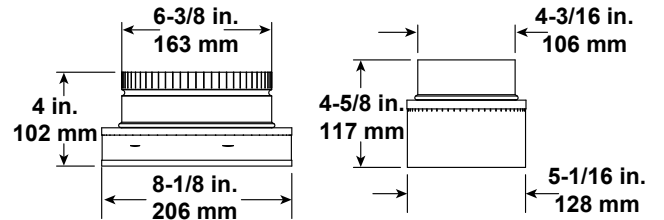

DVP-2SL
Adapter

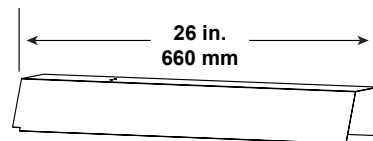

DVP-HSM-B
Extended Heat Shield

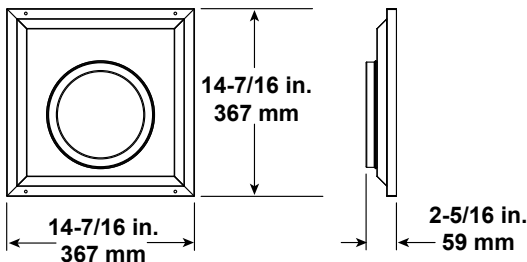

SLP-WT-BK
Wall Thimble-Black

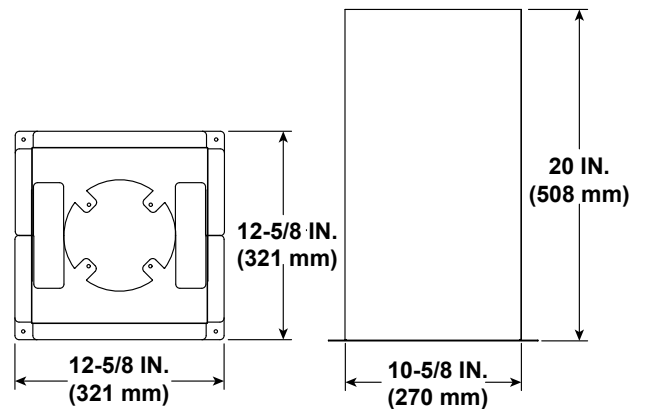

SLP-RDS
ROOF DECK INSULATION SHIELD

Figure 12.10 SLP Series Vent Components

A. Vent Components Diagrams (continued)

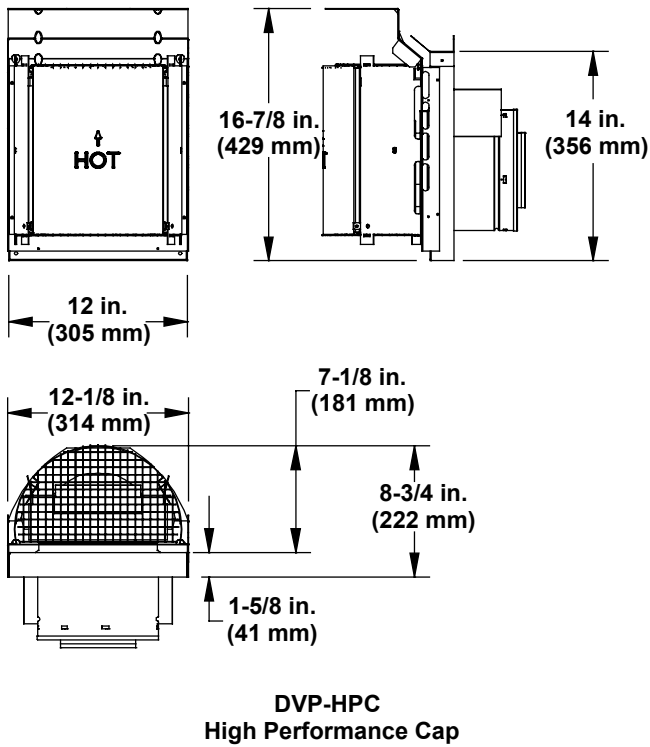
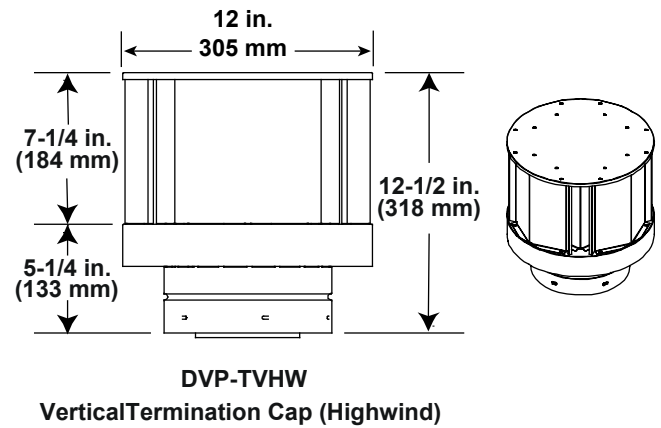
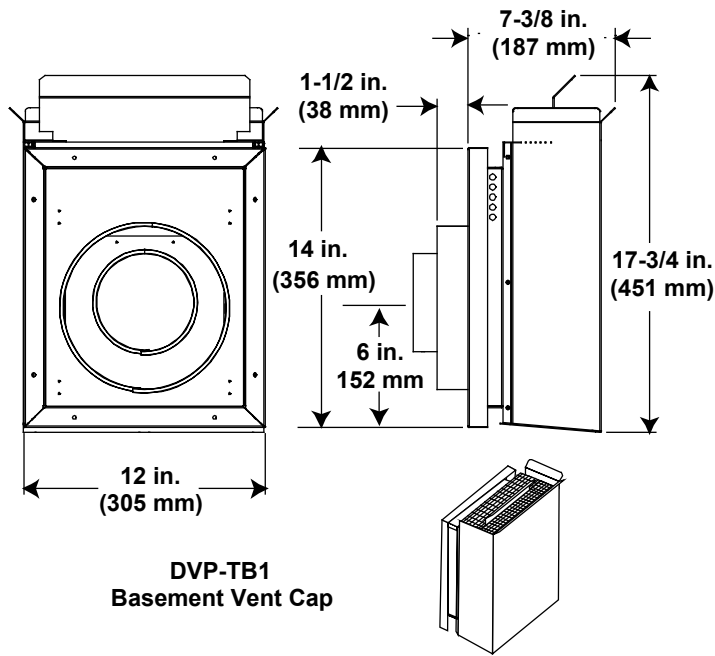
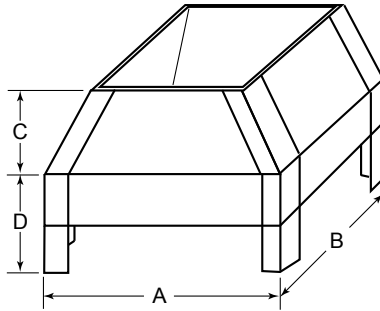

Figure 12.11 SLP Series Vent Components

A. Vent Components Diagrams (continued)



LDS33/LDS46 Decorative Shroud

Catalog #	A		B		C		D	
	in.	mm	in.	mm	in.	mm	in.	mm
LDS33	36	914	36	914	8.5	216	11	279
LDS46	48	1219	72	1829	8.5	216	11	279

Figure 12.12 LDS33 / LDS46 Decorative Shrouds

COAXIAL to COLINEAR VENTING

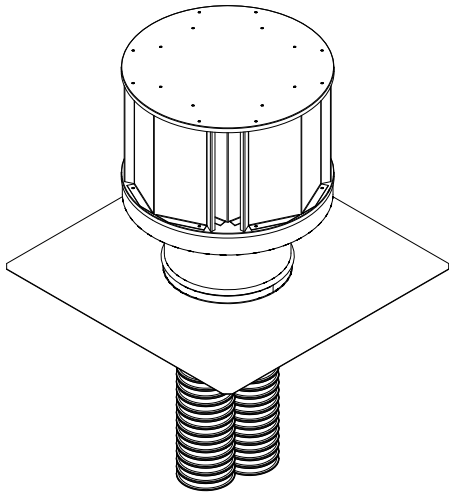

**LINK-DV30B
Flex Liner Kit**



**768-380A
Stainless Steel Flex Pipe
(Required)**

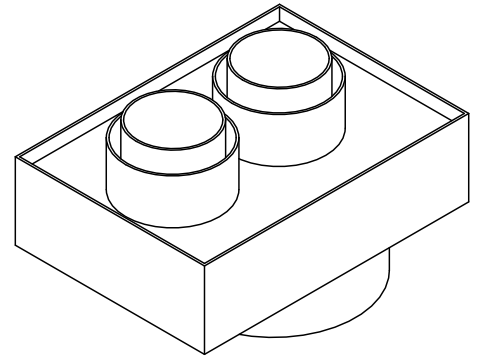

**DV-46DVA-GCL
Coaxial/Colinear Appliance Connector**

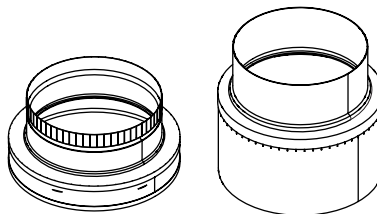

**DVP-2SL
Adapter**

Figure 12.13 Coaxial to Colinear Vent Components

B. Accessories

Optional Remote Controls, Wall Controls and Wall Switches

Follow the instructions supplied with the control installed to operate your fireplace:

For safety:

- Install a switch lock or a wall/remote control with child protection lockout feature.
- Keep remote controls out of reach of children.

See your dealer if you have questions.

Optional Fan

Follow the instructions supplied with the fan kit to operate your fan. See your dealer if you have questions.

Optional Heat Management Kits

Follow the instructions supplied with the kit for operation.

- Preparation of the appliance for installation of a heat management kit is discussed in Section 6.B.

Contact your dealer if you have questions.

Optional Black Glass or Fiber Refractory Kit

Follow the instructions supplied to install the kit. Contact your dealer if you have questions.

Heatilator, a brand of Hearth & Home Technologies
7571 215th Street West, Lakeville, MN 55044
www.heatilator.com

Please contact your Heatilator dealer with any questions or concerns.
For the location of your nearest Heatilator dealer,
please visit www.heatilator.com.

Printed in U.S.A. - Copyright 2023