

Owner's Manual

Operation and Maintenance

CAUTION! Risk of Fire! DO NOT store instruction manuals inside fireplace cavity. High temperatures could cause a fire.

INSTALLER: Leave this manual with the appliance, not inside the appliance.

CONSUMER: Retain this manual for future reference. Do not store inside the appliance. Contact your dealer with questions regarding installation, operation or service.

NOTICE: DO NOT discard this manual!

heatilator[®]
The first name in fireplaces

Models:

NDV3630I-B
NDV3630IL-B
NDV3933I-B
NDV3933IL-B
NDV4236I-B
NDV4236IL-B
NDV4236I-NVR
NDV4842I-B
NDV4842IL-B

GAS-FIRED
UL
LISTED

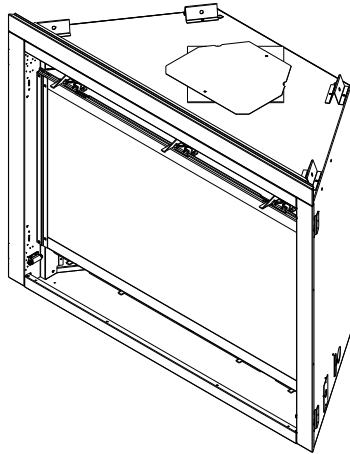

This appliance may be installed as an OEM installation in manufactured home (USA only) or mobile home and must be installed in accordance with the manufacturer's instructions and the *Manufactured Home Construction and Safety Standard, Title 24 CFR, Part 3280* in the United States, or the *Standard for Installation in Mobile Homes, CAN/CSA Z240 MH Series*, in Canada.

This appliance is only for use with the type(s) of gas indicated on the rating plate. This appliance is not convertible for use with other gases, unless a certified kit is used.

⚠ WARNING:

FIRE OR EXPLOSION HAZARD

Failure to follow safety warnings exactly could result in serious injury, death, or property damage.

- **DO NOT** store or use gasoline or other flammable vapors and liquids in the vicinity of this or any other appliance.
- **What to do if you smell gas**
 - **DO NOT** try to light any appliance.
 - **DO NOT** touch any electrical switch. **DO NOT** use any phone in your building.
 - Leave the building immediately.
 - Immediately call your gas supplier from a neighbor's phone. Follow the gas supplier's instructions.
 - If you cannot reach your gas supplier, call the fire department.
- Installation and service must be performed by a qualified installer, service agency, or the gas supplier.

⚠ DANGER



HOT GLASS WILL CAUSE BURNS.

DO NOT TOUCH GLASS UNTIL COOLED.

NEVER ALLOW CHILDREN TO TOUCH GLASS.

A barrier designed to reduce the risk of burns from the hot viewing glass is provided with this appliance and must be installed for the protection of children and other at-risk individuals.

Decorative barrier front must be ordered separately at time of appliance purchase.

1 Welcome

Read this manual before operating this appliance.
Please retain this Owner's Manual for future reference.

Read the Installation Manual before making any installation or finishing changes.

A. Congratulations

Congratulations on selecting a Heatilator gas fireplace, an elegant and clean alternative to wood burning fireplaces. The Heatilator gas fireplace you have selected is designed to provide the utmost in safety, reliability, and efficiency.

As the owner of a new fireplace, you'll want to read and carefully follow all of the instructions contained in this owner's manual. Pay special attention to all cautions and warnings.

This owner's manual should be retained for future reference. We suggest that you keep it with your other important documents and product manuals.

The information contained in this owner's manual, unless noted otherwise, applies to all models and gas control systems.

Your new Heatilator gas fireplace will give you years of durable use and trouble-free enjoyment. Welcome to the Heatilator family of fireplace products!

Local Dealer Information

DEALER: Fill in your name, address, phone and email information here and appliance information below.

Dealer Name: _____
 Address: _____

 Phone: _____
 Email: _____

Appliance Information:

Brand: _____ Model Name: _____
 Serial Number: _____ Date Installed: _____

Listing Label Information/Location The model information regarding your specific fireplace can be found on the rating plate usually located in the control area of the fireplace.

Type of Gas points to: Type of Gas (Sorte De Gaz): **NATURAL GAS** CAN/CSA-P.X.X-XX · FE: %

Gas and Electric Information points to: Minimum Permissible Gas Supply for Purposes of Input Adjustment.
 Approved Minimum (De Gaz) Disponible x.x in. w.c. (Po. Col. d'eau)
 Maximum Pressure (Pression) xx.x in. w.c. (Po. Col. D'eau)
 Maximum Manifold Pressure (Pression) x.x in. w.c. (Po. Col. d'eau)
 Minimum Manifold Pressure (Pression) x.x in. w.c. (Po. Col. d'eau)
 Minimum rate with variable regulator on control valve
 Total Electrical Requirements: 120Vac, 60Hz., less than 12 Amperes

Model Number points to: Model: (Modèle): XXXXXXXXX

Serial Number points to: Serial: (Série): Xxxx-xxx

▲ Safety Alert Key:

- **DANGER!** Indicates a hazardous situation which, if not avoided will result in death or serious injury.
- **WARNING!** Indicates a hazardous situation which, if not avoided could result in death or serious injury.
- **CAUTION!** Indicates a hazardous situation which, if not avoided, could result in minor or moderate injury.
- **NOTICE:** Used to address practices not related to personal injury.

Note: The term “recommend” or “recommended” does not indicate a requirement. It is a best practice suggested by Hearth & Home Technologies®. Failure to perform the recommended task will not result in a safety concern.

Table of Contents

1 Welcome

A. Congratulations	2
B. Limited Warranty	4

2 Product Specific Information

A. Appliance Certification	6
B. Glass Specifications	6
C. BTU Specifications	6

3 Important Safety and Operating Information

A. Appliance Safety	7
B. General Operating Parts	8
C. Fuel Specifications	8
D. Wall and Mantel Temperatures	8
E. Good Faith Wall Surface/TV Guidelines	8
F. Before Lighting Appliance	10
G. Lighting Instructions (IPI)	11
H. Appliance Break-In	12
I. Heat Management	12
J. Operation During A Power Outage (IPI)	12
K. Detailed Component Operating Instructions	13

4 Maintenance and Service

A. Maintenance: Frequency and Tasks	14
B. Maintenance Tasks - Homeowner	14
C. Maintenance Tasks - Qualified Service Technician	16

5 Frequently Asked Questions and Troubleshooting

A. Frequently Asked Questions	17
B. Troubleshooting	18

6 Reference Materials

A. Accessories	20
→ B. Service Parts	21
C. Contact Information	27

→ = Contains updated information.

B. Limited Warranty

Hearth & Home Technologies LLC LIMITED WARRANTY

Hearth & Home Technologies LLC (“HHT”) extends the following warranty for HHT gas, wood, pellet and electric hearth appliances (each a “Product” and collectively, the “Product(s)”) and certain component parts set forth in the table below (“Component Part(s)”) that are purchased from a HHT authorized dealer or distributor.

WARRANTY COVERAGE:

HHT warrants that the Products and their Component Parts will be free from defects in materials and workmanship for the applicable period of Warranty coverage set forth in the table below (“Warranty Period”). If a Product or Component Parts are found to be defective in materials or workmanship during the applicable Warranty Period, HHT will, at our discretion, repair the applicable Component Part(s), replace the applicable Component Part(s), or refund the purchase price of the applicable Product(s). The maximum amount recoverable under this Warranty is limited to the purchase price of the Product. This Warranty is transferable from the original purchaser to subsequent owners, but the Warranty Period will not be extended in duration or expanded in coverage for any such transfer. This Warranty is subject to conditions, exclusions, and limitations as described below.

WARRANTY PERIOD:

Warranty coverage begins at the date of installation. In the case of new home constructions, Warranty coverage begins six months after invoice of the final sale of the Product(s) by an independent, authorized HHT dealer or distributor. However, the Warranty coverage shall commence no later than 24 months following the date of Product shipment from HHT, regardless of the installation or purchase date.

Warranty Period		HHT Manufactured Appliances and Venting					
Component Parts	Labor	Gas	Pellet	Wood	Electric	Component Parts Covered by this Warranty	
1 Year		X	X	X		All parts including handles, external enameled components and other material except as covered by Warranty Conditions, Warranty Exclusions, and Warranty Limitations listed	
2 Years					X	All parts except as covered by Warranty Conditions, Warranty Exclusions, and Warranty Limitations listed	
			X	X		Glass, Electrical components limited to heating element/igniters, Top feed auger assembly, Blowers, Junction Box, Remotes/Wall switches, linear actuator, power cord, vacuum switch, snap disc, wire harnesses and thermocouple	
		X				Electrical components limited to modules, remotes/wall switches, valves, pilots, blowers, junction boxes, wire harnesses, transformers and lights (excluding light bulbs)	
		X		X		Cement Refractory Panels, Glass Liner Panels	
3 years			X			Firepots, burnpots, Harman mechanical feeders	
5 years		X		X		Catalysts, Vented and Vent Free burners and logs	
10 years	1 year	X				Burners, logs and metal/fiber refractory components of HHT manufactured fireplaces or stoves, venting due to poor workmanship	
10 years	3 years		X	X		Castings, Medallions & Baffles, FlexBurn® System (engine, inner cover, access cover and fireback), Firebox and heat exchanger, HHT Chimney & Terminations, Manifolds	
20 years	3 years	X				Firebox and heat exchanger	
All purchased replacement parts and optional accessories							
1 Year	None	X	X	X	X	All purchased replacement parts and optional accessories	

WARRANTY CONDITIONS:

- Because HHT cannot control the quality of any Products sold by unauthorized sellers, this Warranty only covers Products that are purchased through an HHT authorized dealer or distributor unless otherwise prohibited by law; a list of HHT authorized dealers is available on the HHT branded websites.
- This Warranty is only valid while the applicable Product remains at the site of original installation.
- This Warranty is only valid in the country in which the HHT authorized dealer or distributor that sold the applicable Product is authorized to sell applicable Product.
- Contact your installing distributor or dealer for Warranty service. If the installing dealer or distributor is unable to provide necessary parts, contact the nearest HHT authorized dealer or supplier. Additional service fees may apply if you are seeking Warranty service from a dealer other than the dealer from whom you originally purchased the applicable Product.
- No HHT consumer should bear cost of warranty service or costs incurred while servicing warranty claims (i.e., travel, gas, or mileage) when the service is performed within the terms of this Warranty. Check with your dealer or distributor in advance for any costs to you when arranging a warranty call. Travel and shipping charges for parts are not covered by this Warranty.

WARRANTY EXCLUSIONS:

This Warranty does not cover the following:

- Changes in surface finishes as a result of normal use. As a heating appliance, some changes in color of interior and exterior surface finishes may occur. This is not a flaw and is not covered under the Warranty.
- Damage to printed, plated, or enameled surfaces caused by fingerprints, accidents, misuse, scratches, melted items or other external sources and residues left on the plated surfaces from the use of abrasive cleaners or polishes.
- Repair or replacement of parts that are subject to normal wear and tear during the Warranty Period are not covered. These parts include: paint, wood and pellet gaskets, firebricks, wood grates, flame guides, batteries and the discoloration of glass.
- Minor expansion, contraction, or movement of certain parts causing noise. These conditions are normal and complaints related to this noise are not covered by this Warranty.
- Damages resulting from: (1) failure to install, operate, or maintain the applicable Product in accordance with the installation instructions, operating instructions, and listing agent identification label furnished with the applicable Product; (2) failure to install the applicable Product in accordance with local building codes; (3) shipping or improper handling; (4) improper operation, abuse, misuse, continued operation with damaged, corroded or failed components, accident, or improperly/incorrectly performed repairs; (5) environmental conditions, inadequate ventilation, negative pressure, or drafting caused by tightly sealed constructions, insufficient make-up air supply, or handling devices such as exhaust fans or forced air furnaces or other such causes; (6) use of fuels other than those specified in the operation instructions; (7) installation or use of components not supplied with the applicable Product or any other components not expressly authorized and approved by HHT; (8) modification of the appliance not expressly authorized and approved by HHT in writing; and/or (9) interruptions or fluctuations of electrical power supply to the applicable Product.
- Non-HHT venting components, hearth connections or other accessories used in conjunction with the applicable Product.
- Any part of a pre-existing fireplace system in which an insert or a decorative gas applicable Product is installed.
- HHT's obligation under this Warranty does not extend to the Product's capability to heat the desired space. Information is provided to assist the consumer and the dealer in selecting the proper Product for the application. Consideration must be given to the Product location and configuration, environmental conditions, insulation and air tightness of the structure.

This warranty is void if:

- The applicable Product has been over-fired, operated in atmospheres contaminated by chlorine, fluorine, or other damaging chemicals. Over-firing can be identified by, but not limited to, warped plates or tubes, deformation/warping of interior cast iron structure or components, rust colored cast iron, bubbling, cracking and discoloration of steel or enamel finishes.
- The applicable Product is subjected to prolonged periods of dampness or condensation.
- There is any damage to the applicable Product due to water or weather damage which is the result of, but not limited to, improper chimney or venting installation.

LIMITATIONS OF REMEDIES AND LIABILITY:

- **EXCEPT TO THE EXTENT PROVIDED BY LAW, HHT MAKES NO EXPRESS WARRANTIES OTHER THAN THE WARRANTY SPECIFIED HEREIN. The owner's exclusive remedy and HHT's sole obligation under this Warranty or in contract, tort or otherwise, shall be limited to, at HHT's sole option, replacement of the Component Part(s), repair of the Component Part(s), or refund of the original purchase price of the applicable Product(s). In no event will HHT be liable for any incidental or consequential damages caused by defects in the applicable Product. Some States do not allow the exclusion or limitation of incidental or consequential damages, so the above limitation or exclusion may not apply to you. This Warranty gives you specific legal rights and you may also have other rights which vary from State to State. THE DURATION OF ANY IMPLIED WARRANTY IS LIMITED TO DURATION OF THE EXPRESSED WARRANTY SPECIFIED ABOVE FOR THE APPLICABLE PRODUCT. Some States do not allow limitations on how long an implied warranty lasts, so the above limitation may not apply to you.**

2 Product Specific Information

A. Appliance Certification

MODELS: NDV3630I-B, NDV3630IL-B,
NDV3933I-B, NDV3933IL-B
NDV4236I-B, NDV4236IL-B
NCV4236I-NVR
NDV4842I-B, NDV4842IL-B

LABORATORY: Underwriters Laboratories, Inc. (UL)

TYPE: Direct Vent Heater

STANDARD: CSA / ANSI Z21.88-2019 • CSA 2.33-2019

This product is listed to ANSI standards for “Vented Gas Fireplace Heaters” and applicable sections of “Gas Burning Heating Appliances for Manufactured Homes and Recreational Vehicles”, and “Gas Fired Appliances for Use at High Altitudes”.

NOTICE: This installation must conform with local codes. In the absence of local codes you must comply with the National Fuel Gas Code, ANSI Z223.1-latest edition in the U.S.A. and the CAN/CGA B149 Installation Codes in Canada.

NOT INTENDED FOR USE AS A PRIMARY HEAT SOURCE.

This appliance is tested and approved as either supplemental room heat or as a decorative appliance. It should not be factored as primary heat in residential heating calculations.

Installation and service of this appliance should be performed by qualified personnel. Hearth & Home Technologies recommends HHT Factory Trained or NFI certified professionals.



B. Glass Specifications

Hearth & Home Technologies appliances manufactured with tempered glass may be installed in hazardous locations such as bathtub enclosures as defined by the Consumer Product Safety Commission (CPSC). The tempered glass has been tested and certified to the requirements of **ANSI Z97.1** and **CPSC 16 CFR 1202** (Safety Glazing Certification Council **SGCC# 1595** and **1597**. Architectural Testing, Inc. Reports **02-31919.01** and **02-31917.01**).

This statement is in compliance with **CPSC 16 CFR Section 1201.5** “Certification and labeling requirements” which refers to **15 U.S. Code (USC) 2063** stating “...Such certificate shall accompany the product or shall otherwise be furnished to any distributor or retailer to whom the product is delivered.”

Some local building codes require the use of tempered glass with permanent marking in such locations. Glass meeting this requirement is available from the factory. Please contact your dealer or distributor to order.

C. BTU Specifications

Models (U.S. or Canada)		Maximum Input BTU/h	Minimum Input BTU/h	Orifice Size (DMS)
NDV3630I-B (NG)	(0-2000 FT)	20,000	14,000	.083 in.
NDV3630IL-B (Propane)	(0-2000 FT)	18,500	13,500	1.25 mm
NDV3933I-B (NG)	(0-2000 FT)	22,000	15,000	#43
NDV3933IL-B (Propane)	(0-2000 FT)	20,000	14,500	#55
NDV4236I-B (NG)	(0-2000 FT)	25,000	17,000	#42
NDV4236IL-B (Propane)	(0-2000 FT)	24,000	17,000	#54
NDV4236I-NVR (NG)	(0-2000 FT)	25,000	17,000	#42
NDV4236IL-NVR (Propane)	(0-2000 FT)	24,000	17,000	#54
NDV4842I-B (NG)	(0-2000 FT)	27,500	19,500	#39
NDV4842IL-B (Propane)	(0-2000 FT)	26,500	18,500	#53

3 Important Safety and Operating Information

A. Appliance Safety

WARNING! DO NOT operate fireplace before reading and understanding operating instructions. Failure to operate fireplace according to operating instructions could cause fire or injury.



HOT GLASS WILL CAUSE BURNS.

DO NOT TOUCH GLASS UNTIL COOLED.

NEVER ALLOW CHILDREN TO TOUCH GLASS.

- Keep children away.
- CAREFULLY SUPERVISE children in same room as fireplace.
- Alert children and adults to hazards of high temperatures.

High temperatures may ignite clothing or other flammable materials.

- Clothing, furniture, draperies, and other flammable materials must not be placed on or near the appliance.

A barrier designed to reduce the risk of burns from the hot viewing glass is provided with this appliance and must be installed for the protection of children and other at-risk individuals. DO NOT operate the appliance with the barrier removed. If the barrier becomes damaged, the barrier must be replaced with the manufacturer's barrier for this appliance.

Contact your dealer or Hearth & Home Technologies if the barrier is not present or help is needed to properly install one.

- Young children should be carefully supervised when they are in the same room as the appliance. Toddlers, young children and others may be susceptible to accidental contact burns.

A physical barrier is recommended if there are at risk individuals in the house. To restrict access to a fireplace or stove, install an adjustable safety gate to keep toddlers, young children and other at risk individuals out of the room and away from hot surfaces.

- Install a switch lock or a wall/remote control with child protection lockout feature.
- Keep remote controls out of reach of children.
- Never leave children alone near a hot fireplace, whether operating or cooling down.
- Teach children to NEVER touch the fireplace.

- Consider not using the fireplace when children will be present.

Contact your dealer for more information, or visit: www.hpba.org/Product-Info/Fireplace-Stove-Heater/Glass-Fronts-Safety.

To prevent unintended operation when not using your fireplace for an extended period of time (summer months, vacations, trips, etc):

- Remove batteries from remote controls.
- Turn off wall controls.
- Unplug 3 volt adapter plug (IPI) and remove batteries on IPI models.



WARNING: This product and the fuels used to operate this product (liquid propane or natural gas), and the products of combustion of such fuels, can expose you to chemicals including benzene, which is known to the State of California to cause cancer and reproductive harm. For more information go to: www.P65Warnings.ca.gov.

Clear Space

WARNING! DO NOT place combustible objects in front of the fireplace or block fireplace openings. High temperatures could start a fire. See Figure 3.1.

Avoid placing candles and other heat-sensitive objects on mantel or hearth. Heat could damage these objects.

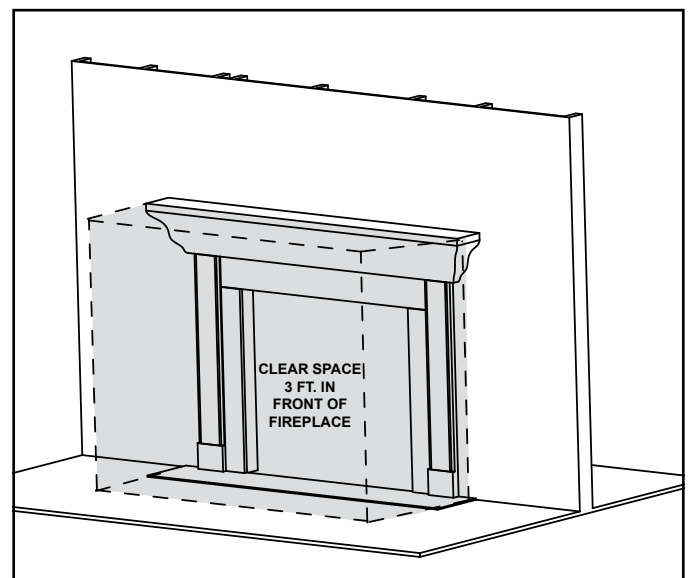

Figure 3.1 Clear Space Requirement - All Models

B. General Operating Parts

Figure 3.2 references the general operating parts of the appliance and the section of this manual in which they are discussed.

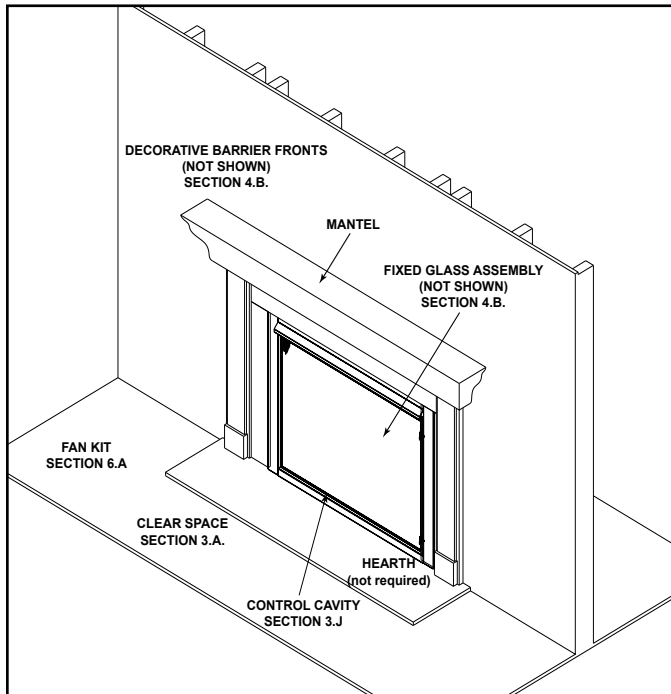

Figure 3.2 General Operating Parts

C. Fuel Specifications

WARNING! Risk of Fire or Explosion! Appliance must be set up for compatible gas type!

- This appliance is designed to operate on either natural gas or propane. Make sure the appliance is compatible with gas type selected for installation site.
- Conversions must be made by a qualified service technician using Hearth & Home Technologies specified and approved parts.

D. Wall and Mantel Temperatures

ANSI/CSA Standards

The American National Standards Institute (ANSI) and Canadian Standards Association (CSA) write the safety and performance standards to which all gas fireplaces are tested. The following are the allowable temperatures around and on a gas fireplace per the ANSI/CSA standards:

Combustible Mantel and Surfaces around a Fireplace

The allowable temperature rise above ambient is 117 °F for all exposed combustible surfaces around the fireplace, including the mantel, when installed according to the installation instructions. Non-combustible surfaces and mantels do not have a maximum temperature limit; however the installation instructions must still be followed for any restrictions on placement of non-combustible materials on or around the fireplace.

Example: The mantel above a fireplace in a room that is 70 °F is allowed to reach but not exceed 187°F (70 °F+117 °F = 187 °F).

E. Good Faith Wall Surface/TV Guidelines

Figure 3.3 shows the approximate wall surface temperatures above the center of the appliance at various heights above the appliance opening.

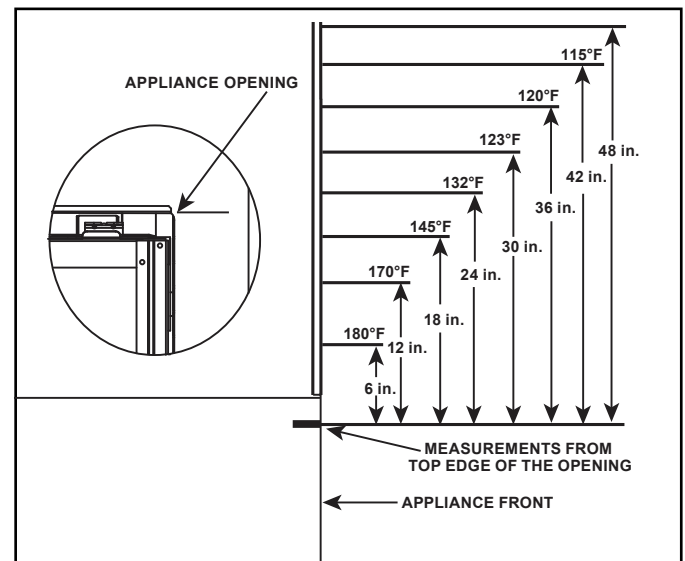
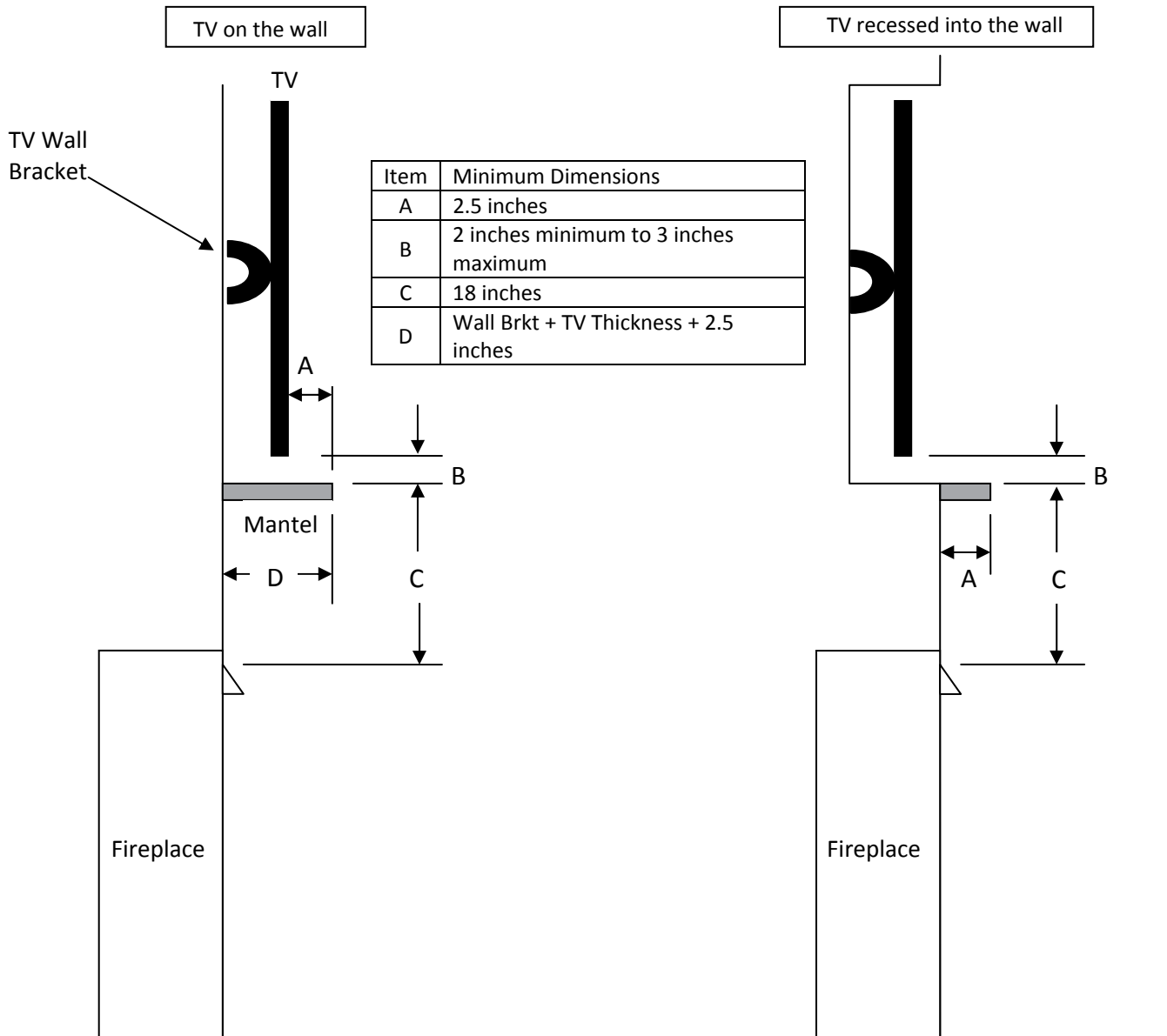

Figure 3.3 Maximum Wall Surface Temperatures Above Appliance

NOTICE: Surface temperatures listed above are taken with a temperature measuring probe as prescribed by the test standard used for appliance certification. Temperatures on walls or mantels taken with an infrared thermometer may yield increased temperatures of up to 30 °F (17 °C) or more depending on the thermometer settings and material characteristics being measured.

Good Faith Guidelines for TV Installations Above Appliance



Notes:

1. These are good faith recommended clearances only and not a guarantee of compliance with all TV manufacturers' maximum allowable operating temperatures.
2. Since every home has unique air flow characteristics and maximum allowable operating temperatures can vary from manufacturer to manufacturer and from model to model, actual TV temperatures should be validated at the time of each installation. TVs should not be used in situations where the actual TV temperature exceeds the manufacturers' maximum allowable operating temperatures identified in the TV's technical specifications. Contact the TV's manufacturer directly if you cannot locate this information or have questions regarding the information.
3. Mantel height and depth must conform to mantel requirements specified in the fireplace installation manual.
4. "C" dimension taken from the top of the hood or fireplace opening.
5. Suggestions on how to further reduce TV temperatures:
 - a. Increase "A" dimension.
 - b. Increase "C" dimension, however, increasing "B" dimension beyond maximum recommended typically results in higher temperatures.

Figure 3.4. Good Faith TV Guidelines

F. Before Lighting Appliance

Before operating this fireplace for the first time, **it is recommended that a qualified service technician:**

- Verify all shipping materials have been removed from inside and/or underneath the firebox.
- Review proper placement of logs, ember material and/or other decorative materials.
- Check the wiring.
- Check the air shutter adjustment.
- Ensure that there are no gas leaks.
- Ensure that the glass is sealed and in the proper position and that the integral barrier is in place.

WARNING! Risk of Fire or Asphyxiation! DO NOT operate fireplace with fixed glass assembly removed.

G. Lighting Instructions (IPI)

The IPI system may be operated with two D-cell batteries. When using batteries, unplug the transformer. To prolong battery life, remove them when using the transformer.

FOR YOUR SAFETY READ BEFORE LIGHTING



WARNING: If you do not follow these instructions exactly, a fire or explosion may result causing property damage, personal injury or loss of life.

- A. This appliance is equipped with an intermittent pilot ignition (IPI) device which automatically lights the burner. **DO NOT** try to light the burner by hand.
 - B. **BEFORE LIGHTING**, smell all around the appliance area for gas. Be sure to smell next to the floor because some gas is heavier than air and will settle on the floor.
- WHAT TO DO IF YOU SMELL GAS**
- **DO NOT** try to light any appliance.
 - **DO NOT** touch any electric switch; do not use any phone in your building.
 - Immediately call your gas supplier from a neighbor's phone. Follow the gas supplier's instructions.
 - If you cannot reach your gas supplier, call the fire department.
- C. Use only your hand to push in or turn the gas control knob. Never use tools. If the knob will not push in or turn by hand, **DO NOT** try to repair it, call a qualified service technician. Force or attempted repair may result in a fire or explosion.
 - D. **DO NOT** use this appliance if any part has been under water. Immediately call a qualified service technician to inspect the appliance and to replace any part of the control system and any gas control which has been under water.

LIGHTING INSTRUCTIONS (IPI)

1. This appliance is equipped with an ignition device which automatically lights the burner. **DO NOT** try to light the burner by hand.
2. Wait five (5) minutes to clear out any gas. Then smell for gas, including near the floor. If you smell gas, **STOP!** Follow "B" in the Safety Information located on the top of this label. If you do not smell gas, go to next step.
3. To light the burner:
Equipped with wall switch: Turn ON/OFF switch to ON.
Equipped with remote or wall control: Press ON or FLAME button.
Equipped with thermostat: Set temperature to desired setting.
4. If the appliance does not light after three tries, call your service technician or gas supplier.

**GAS
VALVE**

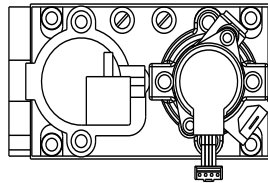

TO TURN OFF GAS TO APPLIANCE

1. Equipped with wall switch: Turn ON/OFF switch to OFF.
Equipped with remote or wall control: Press OFF button.
Equipped with thermostat: Set temperature to lowest setting.
2. Service technician should turn off electric power to the control when performing service.



DANGER



**HOT GLASS WILL CAUSE BURNS.
DO NOT TOUCH GLASS UNTIL COOLED.
NEVER ALLOW CHILDREN TO TOUCH GLASS.**

A barrier designed to reduce the risk of burns from the hot viewing glass is provided with this appliance and must be installed for the protection of children and other at-risk individuals.

WARNING:

DO NOT CONNECT LINE VOLTAGE (110/120 VAC OR 220/240 VAC) TO THE CONTROL VALVE.

Improper installation, adjustment, alteration, service or maintenance can cause injury or property damage. Refer to the owner's information manual provided with this appliance. For assistance or additional information, consult a qualified installer, service agency or the gas supplier.

This appliance needs fresh air for safe operation and must be installed so there are provisions for adequate combustion and ventilation air.



WARNING: This product and the fuels used to operate this product (liquid propane or natural gas), and the products of combustion of such fuels, can expose you to chemicals including benzene, which is known to the State of California to cause cancer and reproductive harm. For more information go to: www.P65Warnings.ca.gov.

Keep burner and control compartment clean. See installation and operating instructions accompanying appliance.

CAUTION:

Hot while in operation. **DO NOT** touch. Keep children, clothing, furniture, gasoline and other liquids having flammable vapors away.

DO NOT operate the appliance with fixed glass assembly removed, cracked or broken. Replacement of the fixed glass assembly should be done by a licensed or qualified service person.

NOT FOR USE WITH SOLID FUEL

For use with natural gas and propane. A conversion kit, as supplied by the manufacturer, shall be used to convert this appliance to the alternate fuel.

Also Certified for Installation in a Bedroom or a Bedsitting Room.

This appliance must be installed in accordance with local codes, if any; if none, follow the *National Fuel Gas Code, ANSI Z223.1/NFPA 54*, or the *National Gas and Propane Installation code, CSA B149.1*.

**For additional information on operating your
Hearth & Home Technologies fireplace, please
refer to www.hearthnhome.com.**

593-913K

H. Appliance Break-In

Initial Break-in Procedure

- The fireplace should be run three to four hours continuously on high.
- Turn the fireplace off and allow it to completely cool.
- Remove fixed glass assembly. See Section 4.B.
- Clean fixed glass assembly. See Section 4.
- Replace the fixed glass assembly and run continuously on high an additional 12 hours.

This cures the materials used to manufacture the fireplace.

NOTICE! Open windows for air circulation during fireplace break-in.

- Some people may be sensitive to smoke and odors.
- Smoke detectors may activate.

I. Heat Management

Heat Output

- Burn Rate

The Novus direct vent models have a variable burn rate which is controlled by the HI/LO knob on the gas valve. Therefore the flame height is adjustable. The HI/LO knob is shown in Figure 3.5. It is located in the control cavity of the appliance.

The HI/LO knob may be adjusted as desired by turning clockwise to the HI position and by turning counterclockwise to the LO position.

- Change fan speed

If an optional fan is installed, follow the instructions included with the fan.

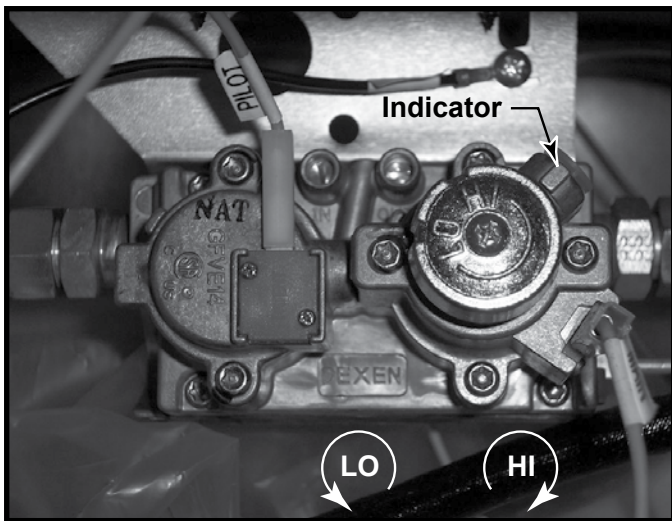

3.5 HI/LO KNOB Location

J. Operation During A Power Outage (IPI)

The IntelliFire intermittent pilot ignition system comes with a battery backup system that enables the system to operate in a power outage. A factory-installed battery pack is located in the control cavity of the appliance. See Figure 3.6. Batteries should not be placed in the battery tray while using electrical power to operate the fireplace. Remove batteries from battery tray when power has been restored.

NOTICE: Batteries should only be used as a power source in the event of an emergency power outage. Batteries should not be used as a primary long-term power source.

To Operate Fireplace Using Battery Power (DC):

1. Access the control cavity of the appliance. See Figure 3.6 for location. The decorative front may need to be removed.
2. Locate the battery tray and insert two D cell batteries. Battery polarity must be correct or module damage will occur. A complete wiring diagram is included in the Electrical section of the Appliance Installation Manual.
3. Turn the appliance on according to the instructions below for the appropriate type of control:

Standard Wall Switch or Factory-Installed ON/OFF Switch:

- Toggle the switch as you would under normal circumstances.

Multifunctional Wired Wall Switch Control System:

- Locate the wired wall switch control module in control cavity.
- Locate battery operation switch on the side of the module.
- Slide the switch to the BATTERY ON or ON position.

NOTICE: Some functionality will be lost when using battery backup including remote control, fan, lights, or any other auxiliary functions that require household 110-120 VAC power.

To Return to Operation Using Electrical (AC) Power:

Standard Wall Switch or Factory-Installed ON/OFF Switch:

- Toggle the switch to OFF and remove the batteries from the battery tray. Replace decorative front on appliance.

Multifunctional Wired Wall Switch Control System:

- Slide the switch to the OFF position. Remove the batteries from the battery tray. Replace decorative front on appliance.

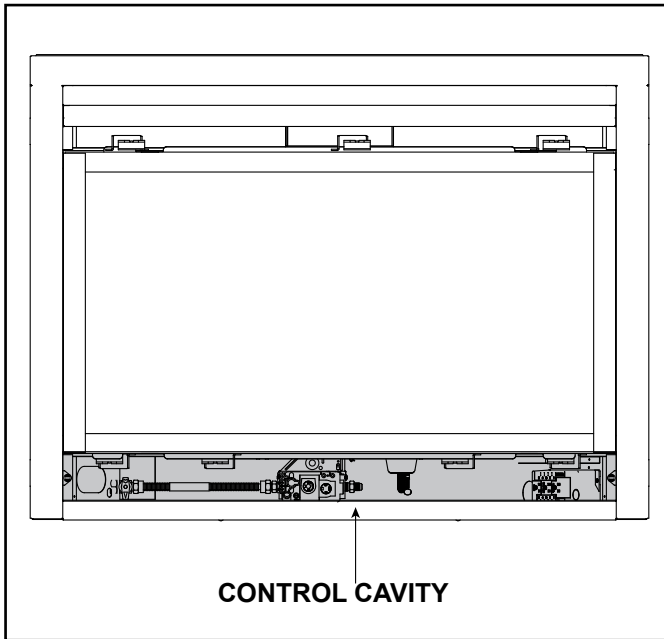

3.6 Control Cavity Location

K. Detailed Component Operating Instructions

IntelliFire™ Ignition System

IntelliFire™, an ignition system exclusively featured in Hearth & Home Technologies products, is an energy-saving pilot ignition system for gas fireplaces and inserts. It provides an ignition flame only when needed and has a battery backup system that supplies power to spark the ignition flame in the event of a power outage.

Intellifire™ is an intermittent pilot ignition, which is an electronic system. The term Intermittent is used because the pilot burner flame is only present when the main burner is operating. When the main burner is off the pilot is also off.

NOTICE: Batteries should not be placed in the battery pack while using the transformer. Remove batteries before using the transformer, and unplug the transformer before installing the batteries. Battery polarity must be correct or module damage will occur.

Appliance ON/OFF

A wall control is used to control the ON/OFF function of the appliance. Follow instructions included with the installed control.

Fan Kit (Optional)

If desired, a fan kit may be added. Contact your dealer to order the correct fan kit. Heat management for the fan is discussed in Section 3.I. Detailed instructions are included with the fan kit.

4 Maintenance and Service

IMPORTANT! Any safety screen, decorative barrier front or guard removed for servicing must be replaced prior to operating the fireplace.

When properly maintained, your fireplace will give you many years of trouble-free service. **Contact your dealer** to answer questions regarding proper operation, troubleshooting and service for your appliance. Visit www.heatilator.com to locate a dealer. We recommend annual service by a qualified service technician.

A. Maintenance: Frequency and Tasks

Task	Frequency	To be completed by
Glass Cleaning	Seasonally	Homeowner
Surrounds, Decorative Barrier Fronts	Annually	
Remote Control	Seasonally	
Venting	Seasonally	
Gasket Seal and Glass Inspection	Annually	Qualified Service Technician
Log Inspection	Annually	
Firebox Inspection	Annually	
Control Compartment & firebox Top	Annually	
Burner Ignition & Operation	Annually	
Electrical Service and Repair	As needed	

B. Maintenance Tasks - Homeowner

Installation and repair should be done by a qualified service technician only. The appliance should be inspected before use and at least annually by a professional service person.

The following tasks may be performed annually by the homeowner. If you are uncomfortable performing any of the listed tasks, please call your dealer for a service appointment.

More frequent cleaning may be required due to excessive lint from carpeting, bedding material, etc. It is imperative that control compartments, burners and circulating air passageways of the appliance be kept clean. Any safety screen, guard, or barrier removed for servicing the appliance must be replaced prior to operating the appliance.

CAUTION! Risk of Burns! The fireplace shall be turned off and cooled before servicing.

Glass Cleaning

Frequency: Seasonally

By: Homeowner

Tools Needed: Protective gloves, gas fireplace glass cleaner, drop cloth and a stable work surface.

CAUTION! Handle fixed glass assembly with care. Glass is breakable.

- Avoid striking, scratching or slamming glass
 - Avoid abrasive cleaners
 - **DO NOT** clean glass while it is hot
- Prepare a work area large enough to accommodate fixed glass assembly and decorative barrier front by placing a drop cloth on a flat, stable surface.

Note: Fixed glass assembly and gasketing may have residue that can stain carpeting or floor surfaces.

- Remove decorative barrier front (or decorative front) from fireplace and set aside on work surface.

WARNING! Risk of Asphyxiation! Handle fixed glass assembly with care. Inspect the gasket to ensure it is undamaged and inspect the glass for cracks, chips or scratches.

- **DO NOT** strike, slam or scratch glass.
- **DO NOT** operate fireplace with glass removed, cracked, broken or scratched.
- Replace as a complete assembly.
- Pull the four (two upper and two lower) glass assembly latches out of the groove on the glass frame. Refer to Figure 4.1.
- Remove the glass assembly from the appliance.

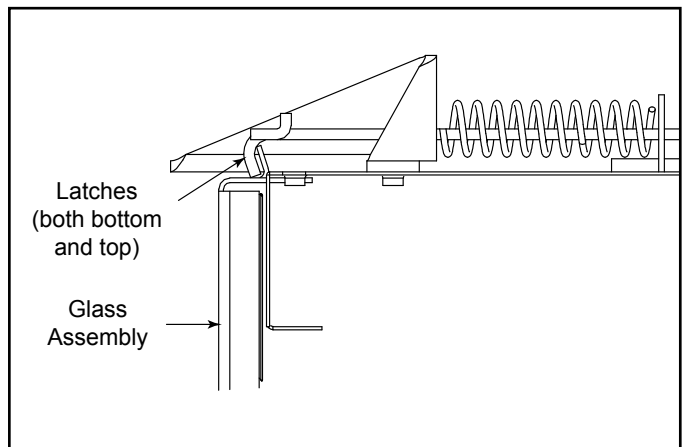

Figure 4.1 Glass Assembly

- Clean glass with a non-abrasive, non-ammonia based, commercially available gas fireplace glass cleaner.
 - Light deposits: Use a soft cloth with soap and water
 - Heavy deposits: Use commercial fireplace glass cleaner (consult with your dealer)
- Carefully set fixed glass assembly in place on fireplace. Hold glass in place with one hand and secure all glass latches with the other hand.
- Inspect and operate all glass latches to ensure they move freely and no obstructions are present.
- Reinstall decorative barrier front.

Decorative Barrier Fronts

Frequency: Annually

By: Homeowner

Tools needed: Protective gloves, stable work surface

- Assess condition of screen and replace as necessary.
- Inspect for scratches, dents or other damage and repair as necessary.
- Check that air intake and discharge areas are not blocked.
- Vacuum and dust surfaces.

Remote Control (Optional)

Frequency: Seasonally

By: Homeowner

Tools needed: Replacement batteries and remote control instructions.

- Locate remote control transmitter and receiver.
- Verify operation of remote. Refer to remote control operation instructions for proper calibration and setup procedure.
- Place batteries as needed in remote transmitters and battery-powered receivers.
- Place remote control out of reach of children.

If not using your fireplace for an extended period of time (summer months, vacations/trips, etc), to prevent unintended operation:

- Remove batteries from remote controls.
- Unplug 3 volt adapter plug on IPI models.

Venting and Termination Cap

Frequency: Seasonally

By: Homeowner

Tools needed: Protective gloves and safety glasses.

- Inspect exposed venting and termination cap for blockage or obstruction such as plants, bird nests, leaves, snow, debris, etc.
- Verify termination cap clearance to subsequent construction (building additions, decks, fences, or sheds).
- Inspect for corrosion or separation.
- Verify caulking and sealing of vent components and termination cap remains intact.
- Inspect draft shield to verify it is not damaged or missing.

C. Maintenance Tasks - Qualified Service Technician

The following tasks must be performed by a qualified service technician.

Gasket Seal and Glass Assembly Inspection

Frequency: Annually

By: Qualified Service Technician

Tools needed: Protective gloves, drop cloth and a stable work surface.

- Inspect gasket seal and its condition.
- Inspect fixed glass assembly for scratches and nicks that can lead to breakage when exposed to heat.
- Confirm there is no damage to glass or glass frame. Replace as necessary.
- Verify that fixed glass assembly is properly retained and attachment components are intact and not damaged. Replace as necessary.

Log Inspection

Frequency: Annually

By: Qualified Service Technician

Tools needed: Protective gloves.

- Inspect for damaged or missing logs. Replace as necessary. Refer to Installation manual for log placement instructions.
- Verify correct log placement and no flame impingement causing sooting. Correct as necessary.

Firebox Inspection

Frequency: Annually

By: Qualified Service Technician

Tools needed: Protective gloves, sandpaper, steel wool, cloths, mineral spirits, primer and touch-up paint.

- Inspect for paint condition, warped surfaces, corrosion or perforation. Sand and repaint as necessary.
- Replace fireplace if firebox has been perforated.

Control Compartment and Firebox Top

Frequency: Annually

By: Qualified Service Technician

Tools needed: Protective gloves, vacuum cleaner, dust cloths

- Vacuum and wipe out dust, cobwebs, debris or pet hair. Use caution when cleaning these areas. Screw tips that have penetrated the sheet metal are sharp and should be avoided.
- Remove all foreign objects.
- Verify unobstructed air circulation.

Pilot and Burner Ignition and Operation

Frequency: Annually

By: Qualified Service Technician

Tools needed: Protective gloves, vacuum cleaner, whisk broom, flashlight, voltmeter, indexed drill bit set, and a manometer.

- Inspect orifice for soot, dirt and corrosion. Verify orifice size is correct. See Service Parts List for proper orifice sizing.
- Verify air shutter setting is correct. See Installation Manual for required air shutter setting. Verify air shutter is clear of dust and debris.
- Verify burner is properly secured and aligned with pilot or igniter.
- Clean off burner top, inspect for plugged ports, corrosion or deterioration. Replace burner if necessary.
- Inspect IPI flame sensing rod for soot, corrosion and deterioration. Polish with 320 grit Emery cloth and/or 3M™ Scotch-Brite Abrasive Hand Pad.
- Verify that there is not a short in flame sense circuit by checking continuity between pilot hood and flame sensing rod. Replace pilot as necessary.
- Verify manifold and inlet pressures. Adjust regulator as required.
- Check all accessible gas-carrying tubes, connections, pipes and other components for leaks.
- Inspect pilot flame pattern and strength. See Figure 4.2 for proper pilot flame pattern. Clean or replace orifice spud as necessary.
- Replace Glowing embers with new dime-size pieces. **DO NOT** block ports or obstruct lighting paths. Refer to appliance installation manual for proper ember placement.
- Check for smooth lighting and ignition carryover to all ports. Verify that there is no ignition delay. Inspect and ensure the lighting of the main burner occurs within four seconds of the main gas valve opening.
- Inspect for lifting or other flame problems.
- Verify batteries have been removed from battery back-up to prevent premature battery failure or leaking.

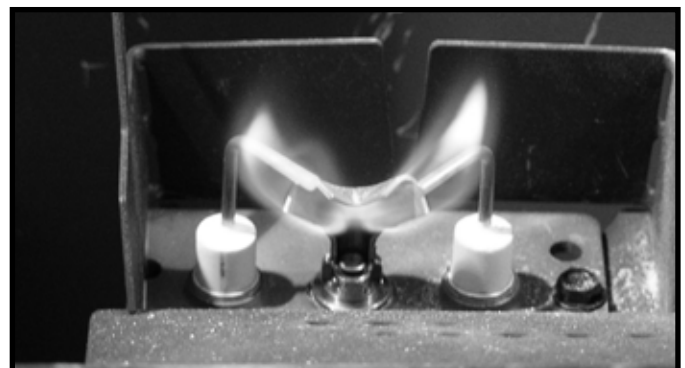

Figure 4.2 IPI Pilot Flame Pattern

5 Frequently Asked Questions and Troubleshooting

A. Frequently Asked Questions

ISSUE	SOLUTIONS
Condensation on the glass	<p>This is a result of gas combustion and temperature variations. Prior to appliance being turned on, the inside of the glass has cooled below the dew point producing a byproduct of combustion: water in the form of condensation. As the fireplace glass warms, the condensation will disappear.</p> <p>In the summer, the inside of your fireplace contains hot humid air from outdoors. When the air from outdoors contacts glass cooled below the dew point by your air conditioning, moisture in that air will condense.</p>
Blue flames	This is a result of normal operation and the flames will begin to yellow as the fireplace is allowed to burn for 20 to 40 minutes.
Erratic flames	<p>Verify that the glass assembly is correctly installed and that all glass latches are engaged over the tabs on the glass frame.</p> <p>Vent baffle/flue restrictor may be needed when long vertical vent runs are used. Refer to Installation Manual, Section 4 Vent Diagrams.</p>
Odor from fireplace	When first operated, this fireplace may release an odor for the first several hours. This is caused by the curing of the paint and the burning off of any oils remaining from manufacturing. Odor may also be released from finishing materials and adhesives used around the fireplace. These circumstances may require additional curing related to the installation environment.
Film on the glass	This is a normal result of the curing process of the paint and logs. Glass should be cleaned within 3 to 4 hours of initial burning to remove deposits left by oils from the manufacturing process. A non-abrasive cleaner such as gas fireplace glass cleaner may be necessary. Contact your dealer.
Metallic noise	Noise is caused by metal expanding and contracting as it heats up and cools down, similar to the sound produced by a furnace or heating duct. This noise does not affect the operation or longevity of the fireplace.
Is it normal to see the pilot flame burn continually?	In an intermittent pilot ignition system (IPI), the pilot flame should turn off when appliance is turned off. Some optional control systems available with IPI models may allow pilot flame to remain lit.
Power Outages (battery backup)	This appliance can be operated on battery power in the event of a power outage. To access the battery pack, the decorative barrier front, mesh and glass assembly must be removed. Refer to Section 3 for more details.
Wall above appliance feels hot to the touch.	No action necessary. This appliance ships with a non-combustible material attached. Specifications of the attached non-combustible material are listed in the Installer's Manual for this appliance.

Contact your dealer for additional information regarding operation and troubleshooting. Visit www.heatilator.com to locate a dealer.

B. Troubleshooting

With proper installation, operation, and maintenance your gas appliance will provide years of trouble-free service. If you do experience a problem, this troubleshooting guide will assist a qualified service technician in the diagnosis of a problem and the corrective action to be taken. This troubleshooting guide can only be used by a qualified service technician. Contact your dealer to arrange a service call by a qualified service technician.

Intellifire Ignition System

Symptom	Possible Cause	Corrective Action
1. Pilot won't light. The ignitor/module makes noise, but no spark.	A. Incorrect wiring.	Verify "S" wire (white) for sensor and "I" wire (orange) for ignitor are connected to correct terminals on module and pilot assembly.
	B. Loose connections or electrical shorts in the wiring.	Verify no loose connections or electrical shorts in wiring from module to pilot assembly. Verify connections underneath pilot assembly are tight; also verify connections are not grounding out to metal chassis, pilot burner, pilot enclosure, mesh screen if present, or any other metal object.
	C. Ignitor gap is too large.	Verify gap of igniter to right side of pilot hood. The gap should be approximately .095 in. (2.41 mm) to .135 in. (3.43 mm).
	D. Module.	Turn ON/OFF rocker switch or wall switch to OFF position. Remove ignitor wire "I" from module. Place a grounded wire about 3/16 in. (5 mm) away from "I" terminal on module. Place ON/OFF rocker switch or wall switch in ON position. If there is no spark at "I" terminal module must be replaced. If there is a spark at "I" terminal, module is fine. Inspect pilot assembly for shorted sparker wire or cracked insulator around electrode. Replace pilot if necessary.
2. Pilot won't light, there is no noise or spark.	A. No power or transformer installed incorrectly.	Verify that transformer is installed and plugged into module. Check voltage of transformer under load at spade connection on module with ON/OFF switch in ON position. Acceptable readings of a good transformer are between 3.2 and 2.8 volts AC.
	B. A shorted or loose connection in wiring configuration or wiring harness.	Remove and reinstall the wiring harness that plugs into module. Verify there is a tight fit. Verify pilot assembly wiring to module. Remove and verify continuity of each wire in wiring harness. Replace any damaged components.
	C. Improper wall switch wiring.	Verify that 110-120 VAC power is "ON" to junction box.
	D. Module not grounded.	Verify black ground wire from module wire harness is grounded to metal chassis of appliance.
	E. Module.	Turn ON/OFF rocker switch or wall switch to OFF position. Remove ignitor wire "I" from module. Place ON/OFF rocker switch or wall switch in ON position. If there is no spark at "I" terminal module must be replaced. If there is a spark at "I" terminal, module is fine. Inspect pilot assembly for shorted sparker wire or cracked insulator around electrode.
3. Pilot sparks, but Pilot will not light.	A. Gas supply.	Verify that incoming gas line ball valve is "open". Verify that inlet pressure reading is within acceptable limits.
	B. Ignitor gap is too large.	Verify gap of igniter to right side of pilot hood. The gap should be approximately .095 in. (2.41 mm) to .135 in. (3.43 mm).
	C. Module is not grounded.	Verify module is securely grounded to metal chassis of appliance.
	D. Module voltage output / Valve/Pilot solenoid ohms readings.	Verify battery voltage is at least 2.7 volts. Replace batteries if voltage is below 2.7.

Intellifire Ignition System - (continued)

Symptom	Possible Cause	Corrective Action
<p>4. Pilot lights but continues to spark, and main burner will not ignite. (If the pilot continues to spark after the pilot flame has been lit, flame rectification has not occurred.)</p>	<p>A. A shorted or loose connection in flame sensing rod.</p>	<p>Verify all connections to wiring diagram in manual. Verify connections underneath pilot assembly are tight. Verify connections are not grounding out to metal chassis, pilot burner, pilot enclosure or screen if present, or any other metal object.</p>
	<p>B. Poor flame rectification or contaminated flame sensing rod.</p>	<p>With fixed glass assembly in place, verify that flame is engulfing flame sensing rod on left side of pilot hood. Flame sensing rod should glow shortly after ignition. Verify correct pilot orifice is installed and gas inlet is set to pressure specifications. Polish flame sensing rod with fine steel wool to remove any contaminants that may have accumulated on flame sensing rod.</p>
	<p>C. Module is not grounded.</p>	<p>Verify module is securely grounded to metal chassis of appliance. Verify that wire harness is firmly connected to the module.</p>
	<p>D. Damaged pilot assembly or contaminated flame sensing rod.</p>	<p>Verify that ceramic insulator around the flame sensing rod is not cracked, damaged, or loose. Verify connection from flame sensing rod to white sensor wire. Polish flame sensing rod with fine steel wool to remove any contaminants that may have accumulated on flame sensing rod. Verify continuity with a multimeter with ohms set at lowest range. Replace pilot if any damage is detected.</p>
	<p>E. Module.</p>	<p>Turn ON/OFF rocker switch or wall switch to OFF position. Remove ignitor wire "I" from module. Place ON/OFF rocker switch or wall switch in ON position. If there is no spark at "I" terminal module must be replaced. If there is a spark at "I" terminal, module is fine.</p>

6 Reference Materials

A. Accessories

Install approved accessories per instructions included with accessories. Contact your dealer for a list of approved accessories.

WARNING! Risk of Fire and Electric Shock! Use **ONLY** Hearth & Home Technologies-approved optional accessories with this appliance. Using non-listed accessories could result in a safety hazard and will void the warranty.

Remote Controls, Wall Controls and Wall Switches

After a qualified service technician has installed the remote control, wall control or wall switch, follow the instructions supplied with the control installed to operate your fireplace:

For safety:

- Install a switch lock or a wall/remote control with child protection lockout feature.
- Keep remote controls out of reach of children.

See your dealer if you have questions.

Optional Fan Kit

If desired, a fan kit may be added. Contact your dealer to order the correct fan kit. Heat management for the fan is discussed in Section 3.H. Detailed instructions are included with the fan kit.

Optional Refractory Kit

If desired, a refractory kit may be added. Contact your dealer to order the correct refractory kit. Detailed installation instructions are included with the refractory kit.

Decorative Doors and Fronts

WARNING! Risk of Fire! Install **ONLY** doors or fronts approved by Hearth & Home Technologies. Unapproved doors or fronts may cause appliance to overheat.

This appliance has been supplied with an integral barrier to prevent direct contact with the fixed glass panel. DO NOT operate the appliance with the barrier removed.

Contact your dealer or Hearth & Home Technologies if the barrier is not present or help is needed to properly install one.

For more information refer to the instructions supplied with your decorative door or front.

B. Service Parts

heatilator[®]
The first name in fireplaces

NDV3630I-B, NDV3933I-B, NDV4236I-B, NDV4842I-B, NDV4236I-NVR

Service Parts
Novus Gas Fireplace - DV

Beginning Manufacturing Date: Feb 2016

Ending Manufacturing Date: Oct 2022

Manufacturing Reactivation Date: May 2022

NDV4236I-NVR Ending Manufacturing Date: April 2023

Log Set Assembly

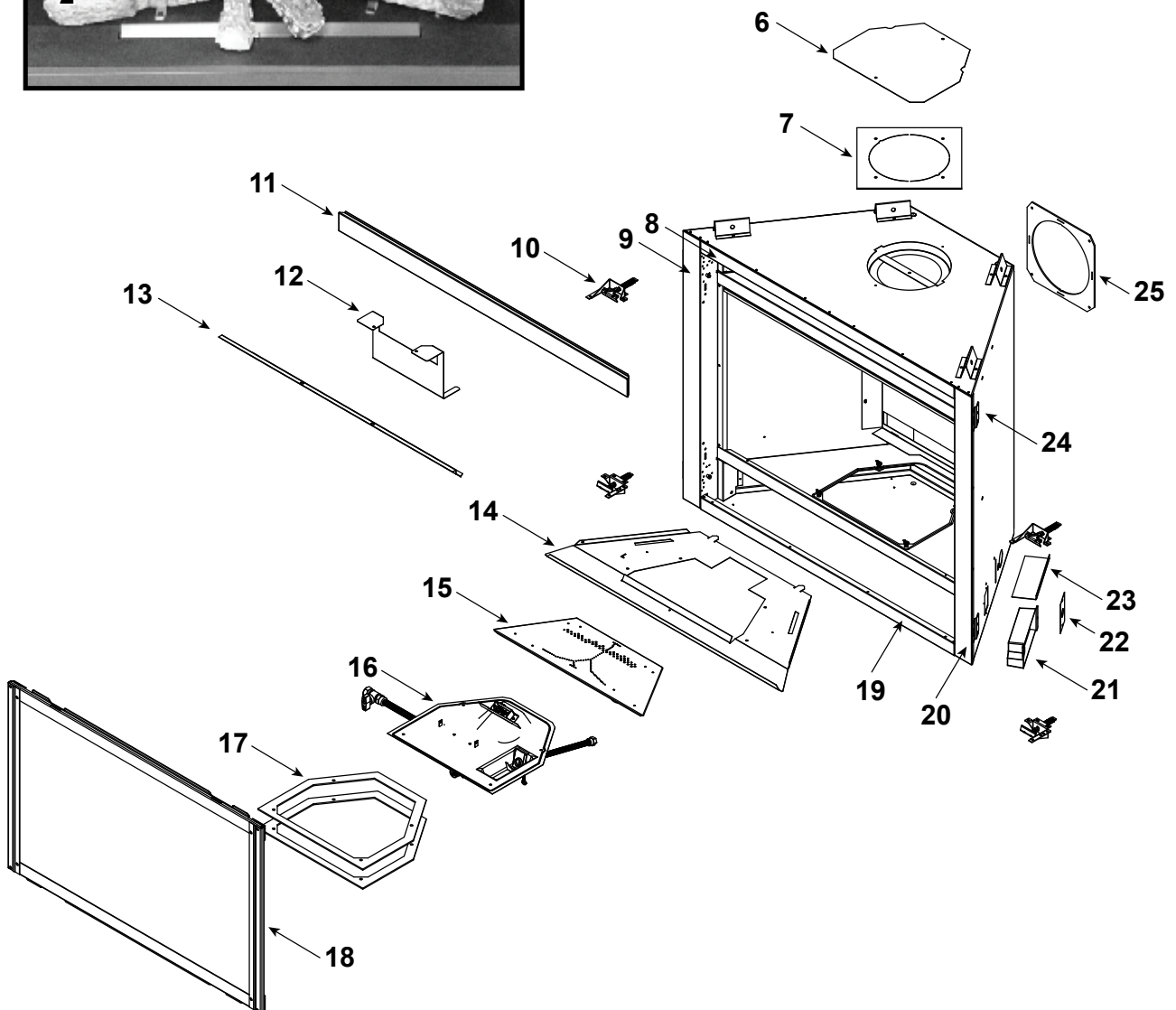
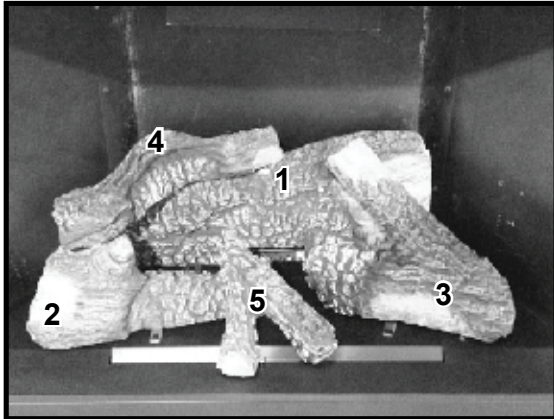

Part number list on following page.

IMPORTANT: THIS IS DATED INFORMATION. Parts must be ordered from a dealer or distributor. **Hearth and Home Technologies does not sell directly to consumers.** Provide model number and serial number when requesting service parts from your dealer or distributor.



**Stocked
at Depot**

ITEM	DESCRIPTION	COMMENTS	PART NUMBER	
	Log Set Assembly		SRV2380-070	Y
1	Rear Log		SRV2380-071	
2	Front Left Log		SRV2380-072	
3	Front Right Log		SRV2380-073	
4	Top Log		SRV2380-074	
5	Middle Log		SRV2380-075	
6	Intake Cover Plate		2166-450	
7	Intake Cover Gasket		4031-239	
8	Not replaceable must order overlay (CUST4018-001)		4055-194	
9			4055-133	
10	Glass Latch Assembly	Qty 4 req	2382-400	Y
11	Dry Wall Lip		4031-205	
12	Exhaust Baffle		2382-129	
13	Glass Shield		4031-217	
14	Hearth Pan		2380-111	
15	Burner Assembly		2380-007	Y
16	Valve Assembly		Refer to valve page	
17	Gasket, Valve Plate	Qty 2 req	4055-135	
18	Glass Frame Assembly		GLA2380-018	Y
19	Not replaceable must order overlay (CUST4018-001)		4055-194	
20			4055-133	
21	Junction box	Pre LC5475379	SRV4021-013	Y
		Post LC5475379	SRV2326-013	Y
22	Cover Plate		SRV4031-222	
23	Shield Junction Box	Pre LC5475379	4031-193	
24	Nailing Flange	Qty 4 req	SRV4044-161	
25	Back Gasket		SRV4000-225	
	Firebox Overlay Kit		OVERLAY-NDV3630	
	Touch-up Paint, Interior	Pre LC5475379	SRV4021-110	
		Post LC5475379	TUPB-12	
	Touch-up Paint, Exterior		TUPB-12	
	Battery Pack		SRV593-594	Y
	Thumb Screws	Pkg of 25	4021-558/25	Y
	Lava Rock Bag Assembly		SRV4040-094	
	Lava Rock, 3 Lbs		4021-297	
	Mineral Wool		SRV14333	

Additional service part numbers appear on following page.

IMPORTANT: THIS IS DATED INFORMATION. Parts must be ordered from a dealer or distributor. **Hearth and Home Technologies does not sell directly to consumers.** Provide model number and serial number when requesting service parts from your dealer or distributor.



**Stocked
at Depot**

ITEM	DESCRIPTION	COMMENTS	PART NUMBER	
	Log Set Assembly		SRV2381-070	Y
1	Rear Log		SRV2380-071	
2	Front Left Log		SRV2381-072	
3	Front Right Log		SRV2381-073	
4	Top Log		SRV2380-074	
5	Middle Log		SRV2380-075	
6	Intake Cover Plate		2166-450	
7	Intake Cover Gasket		4031-239	
8	Not replaceable must order overlay (CUST4018-001)		4055-195	
9			4055-133	
10	Glass Latch Assembly	Qty 4 req	2382-400	Y
11	Dry Wall Lip		4031-206	
12	Exhaust Baffle		2382-129	
13	Glass Shield		4031-218	
14	Hearth Pan		2381-111	
15	Burner Assembly		2381-007	Y
16	Valve Assembly		Refer to Valve page	
17	Gasket, Valve Plate	Qty 2 req	4055-135	
18	Glass Frame Assembly		GLA2381-018	Y
19	Not replaceable must order overlay (CUST4018-001)		4055-195	
20			4055-133	
21	Junction box	Pre LC5475379	SRV4021-013	Y
		Post LC5475379	SRV2326-013	Y
22	Cover Plate		SRV4031-222	
23	Shield Junction Box	Pre LC5475379	4031-193	
24	Nailing Flange	Qty 4 req	SRV4044-161	
25	Back Gasket		SRV4000-225	
	Firebox Overlay Kit		OVERLAY-NDV3933	
	Touch-up Paint, Interior	Pre LC5475379	SRV4021-110	
		Post LC5475379	TUPB-12	
	Touch-up Paint, Exterior		TUPB-12	
	Battery Pack		SRV593-594	Y
	Thumb Screws	Pkg of 25	4021-558/25	Y
	Lava Rock Bag Assembly		SRV4040-094	
	Lava Rock, 3 Lbs		4021-297	
	Mineral Wool		SRV14333	

Additional service part numbers appear on following page.

IMPORTANT: THIS IS DATED INFORMATION. Parts must be ordered from a dealer or distributor. **Hearth and Home Technologies does not sell directly to consumers.** Provide model number and serial number when requesting service parts from your dealer or distributor.



**Stocked
at Depot**

ITEM	DESCRIPTION	COMMENTS	PART NUMBER	
	Log Set Assembly		SRV2382-070	Y
1	Rear Log		SRV2382-071	
2	Front Left Log		SRV2381-072	
3	Front Right Log		SRV2381-073	
4	Top Log		SRV2382-074	
5	Middle Log		SRV2380-075	
6	Intake Cover Plate		2166-450	
7	Intake Cover Gasket		4031-239	
8	Not replaceable must order overlay (CUST4018-001)		4055-196	
9			4055-133	
10	Glass Latch Assembly	Qty 4 req	2382-400	Y
11	Dry Wall Lip		4031-207	
12	Exhaust Baffle		2382-129	
13	Glass Shield		4031-219	
14	Hearth Pan		2382-111	
15	Burner Assembly		2382-007	Y
16	Valve Assembly		Refer to valve page	
17	Gasket, Valve Plate	Qty 2 req	4055-135	
18	Glass Frame Assembly		GLA2382-018	Y
19	Not replaceable must order overlay (CUST4018-001)		4055-196	
20			4055-133	
21	Junction Box (For -B Units)	Pre LC5475379	SRV4021-013	Y
		Post LC5475379	SRV2326-013	Y
	Junction Box (Corded, Only for NDV4236I-NVR)	Pre LC5475379	2382-013	Y
		Post LC5475379	2326-014	Y
22	Cover Plate		SRV4031-222	
23	Shield Junction Box	Pre LC5475379	4031-193	
24	Nailing Flange	Qty 4 req	SRV4044-161	
25	Back Gasket		SRV4000-225	
	Firebox Overlay Kit		OVERLAY-NDV4236	
	Touch-up Paint, Interior	Pre LC5475379	SRV4021-110	
		Post LC5475379	TUPB-12	
	Touch-up Paint, Exterior		TUPB-12	
	Battery Pack		SRV593-594	Y
	Thumb Screws	Pkg of 25	4021-558/25	Y
	Lava Rock Bag Assembly		SRV4040-094	
	Lava Rock, 3 Lbs		4021-297	
	Mineral Wool		SRV14333	

IMPORTANT: THIS IS DATED INFORMATION. Parts must be ordered from a dealer or distributor. **Hearth and Home Technologies does not sell directly to consumers.** Provide model number and serial number when requesting service parts from your dealer or distributor.



Stocked at Depot

ITEM	DESCRIPTION	COMMENTS	PART NUMBER	
	Log Set Assembly		SRV2383-070	Y
1	Rear Log		SRV2383-071	
2	Front Left Log		SRV2383-072	
3	Front Right Log		SRV2383-073	
4	Top Log		SRV2382-074	
5	Middle Log		SRV2383-075	
6	Intake Cover Plate		2166-450	
7	Intake Cover Gasket		4031-239	
8	Not replaceable must order overlay (CUST4018-001)		4055-197	
9			4055-133	
10	Glass Latch Assembly	Qty 4 req	2382-400	Y
11	Dry Wall Lip		4031-208	
12	Exhaust Shield		2382-129	
13	Glass Shield		4031-220	
14	Hearth Pan		2383-111	
15	Burner Assembly		2383-007	Y
16	Valve Assembly		Refer to valve page	
17	Gasket, Valve Plate	Qty 2 req	4055-135	
18	Glass Frame Assembly		GLA2383-018	
19	Not replaceable must order overlay (CUST4018-001)		4055-197	
20			4055-133	
21	Junction box	Pre LC5475379	SRV4021-013	Y
		Post LC5475379	SRV2326-013	Y
22	Cover Plate		SRV4031-222	
23	Shield Junction Box	Pre LC5475379	4031-193	
24	Nailing Flange	Qty 4 req	SRV4044-161	
25	Back Gasket		SRV4000-225	
	Firebox Overlay Kit		OVERLAY-NDV4842	
	Touch-up Paint, Interior	Pre LC5475379	SRV4021-110	
		Post LC5475379	TUPB-12	
	Touch-up Paint, Exterior		TUPB-12	
	Battery Pack		SRV593-594	Y
	Thumb Screws	Pkg of 25	4021-558/25	Y
	Lava Rock Bag Assembly		SRV4040-094	
	Lava Rock, 3 Lbs		4021-297	
	Mineral Wool		SRV14333	

Additional service part numbers appear on following page.

#16 Valve Assembly

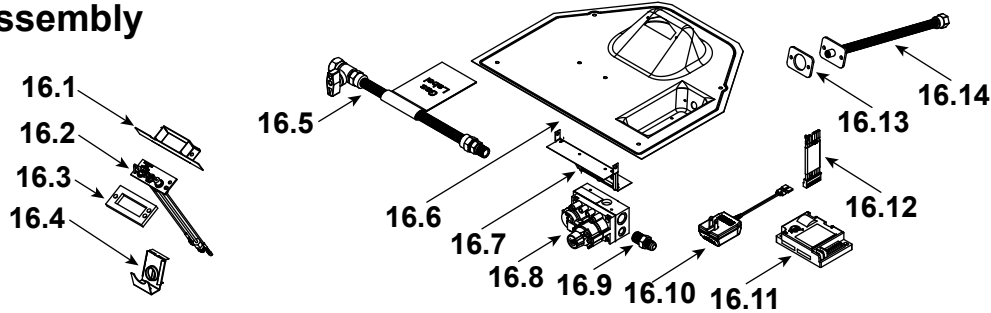

IMPORTANT: THIS IS DATED INFORMATION. Parts must be ordered from a dealer or distributor. **Hearth and Home Technologies does not sell directly to consumers.** Provide model number and serial number when requesting service parts from your dealer or distributor.



Stocked at Depot

ITEM	DESCRIPTION	COMMENTS	PART NUMBER	
16.1	Pilot Shield		2382-131	
16.2	Pilot Assembly NG		SRV2090-012	Y
	Pilot Assembly Propane		2090-013	Y
16.3	Gasket, Pilot Assembly		4021-042	
16.4	Air Shutter Assembly		SRV4055-202	Y
16.5	Flex Ball Valve Assembly		SRV302-320	Y
16.6	Seal Plate Assembly		2382-584	
16.7	Valve Bracket		4055-205	
16.8	Valve NG		750-500	Y
	Valve Propane		2155-501	Y
16.9	Brass Fitting	Pkg of 5	303-315/5	Y
16.10	3 Volt Transformer		SRV593-593	Y
16.11	Module		593-592	Y
16.12	Module Wire Assembly		SRV593-590	Y
16.13	Gasket, Bulkhead		4021-429	
16.14	Bulkhead, Flexible		4021-512	Y
	Wire Assembly , Wall Switch		SRV2118-170	Y
	Orifice NG (.083)	NDV3630I-B	4021-435	Y
	Orifice Propane (1.25mmC)		582-8125	Y
	Orifice NG (#43C)	NDV3933I-B	582-843	Y
	Orifice Propane (#55C)		582-855	Y
	Orifice NG (#42C)	NDV4236I-B & NDV4236I-NVR	582-842	Y
	Orifice Propane (#54C)		SRV582-854	Y
	Orifice NG (#39C)	NDV4842I-B	582-839	Y
	Orifice Propane (#53C)		582-853	Y
	Conversion Kit NG		DCKVN-Novus	Y
	Conversion Kit Propane		DCKVP-Novus	Y
	Pilot Orifice NG		SRV593-528	Y
	Pilot Orifice Propane		SRV593-527	Y
	Regulator NG		SRVNGK-DXV	Y
	Regulator Propane	Not Available - Must Replace Valve		



C. Contact Information



Heatilator, a brand of Hearth & Home Technologies
7571 215th Street West, Lakeville, MN 55044
www.heatilator.com

Please contact your Heatilator dealer with any questions or concerns.
For the location of your nearest Heatilator dealer,
please visit www.heatilator.com.

- NOTES -

NOTICE		
	DO NOT DISCARD THIS MANUAL	
<ul style="list-style-type: none">• Important operating and maintenance instructions included.	<ul style="list-style-type: none">• Read, understand and follow these instructions for safe installation and operation.	<ul style="list-style-type: none">• Leave this manual with party responsible for use and operation.

This product may be covered by one or more of the following patents: (United States) 7077122, 7074035, 7234932, 7322819, 7422011, 7726300, 8147240, 9625149 or other U.S. and foreign patents pending.

2000-945F

Printed in U.S.A. - Copyright 2024