

Installation Manual

Installation and Appliance Setup

This appliance has been retired.
For replacement parts, please refer to the individual
service parts list located on the brand websites.

INSTALLER: Leave this manual with party responsible for use and operation.
OWNER: Retain this manual for future reference.

NOTICE: DO NOT discard this manual!

heatilator
The first name in fireplaces

Models:

NEVO3630I-B

NEVO4236I-B

GAS-FIRED

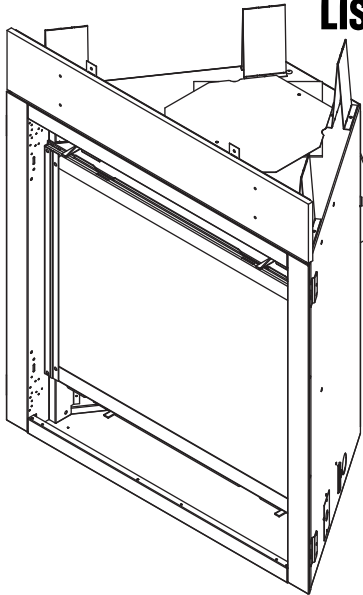

This appliance may be installed as an OEM installation in manufactured home (USA only) or mobile home and must be installed in accordance with the manufacturer's instructions and the *Manufactured Home Construction and Safety Standard, Title 24 CFR, Part 3280* in the United States, or the *Standard for Installation in Mobile Homes, CAN/CSA Z240 MH Series*, in Canada.

This appliance is only for use with the type(s) of gas indicated on the rating plate. This appliance is not convertible for use with other gases, unless a certified kit is used.

In the Commonwealth of Massachusetts installation must be performed by a licensed plumber or gas fitter.
See Table of Contents for location of additional Commonwealth of Massachusetts requirements.

⚠ **WARNING:**

FIRE OR EXPLOSION HAZARD

Failure to follow safety warnings exactly could result in serious injury, death, or property damage.

- **DO NOT** store or use gasoline or other flammable vapors and liquids in the vicinity of this or any other appliance.
- **What to do if you smell gas**
 - **DO NOT** try to light any appliance.
 - **DO NOT** touch any electrical switch. **DO NOT** use any phone in your building.
 - Leave the building immediately.
 - Immediately call your gas supplier from a neighbor's phone. Follow the gas supplier's instructions.
 - If you cannot reach your gas supplier, call the fire department.
- Installation and service must be performed by a qualified installer, service agency, or the gas supplier.

⚠ **DANGER**



**HOT GLASS WILL
CAUSE BURNS.**

**DO NOT TOUCH GLASS
UNTIL COOLED.**

**NEVER ALLOW CHILDREN
TO TOUCH GLASS.**

A barrier designed to reduce the risk of burns from the hot viewing glass is provided with this appliance and shall be installed for the protection of children and other at-risk individuals.

▲ Safety Alert Key:

- **DANGER!** Indicates a hazardous situation which, if not avoided will result in death or serious injury.
- **WARNING!** Indicates a hazardous situation which, if not avoided could result in death or serious injury.
- **CAUTION!** Indicates a hazardous situation which, if not avoided, could result in minor or moderate injury.
- **NOTICE:** Used to address practices not related to personal injury.

Table of Contents

Installation Standard Work Checklist	3	7 Venting and Chimneys	
1 Product Specific and Important Safety Information		A. Assemble Vent Sections	35
A. Appliance Certification	4	B. Assemble Slip Sections	36
B. Glass Specifications	4	C. Secure the Vent Sections	37
C. BTU Specifications	4	D. Disassemble Vent Sections	37
D. High Altitude Installations	4	E. Vertical Termination Requirements	38
E. Non-Combustible Materials Specification	5	F. Horizontal Termination Requirements	39
F. Combustible Materials Specification	5	G. Shrouds (Optional)	41
G. Electrical Codes	5	8 Electrical Information	
H. California	5	A. General Information	42
I. Requirements for the Commonwealth of Massachusetts	6	B. Wiring Requirements	43
2 Getting Started		9 Gas Information	
A. Design and Installation Considerations	7	A. Fuel Conversion	45
B. Wall Surface/TV Guidelines	7	B. Gas Pressure	45
C. Tools and Supplies Needed	7	C. Gas Connection	45
D. Inspect Appliance and Components	7	D. High Altitude Installations	45
3 Framing and Clearances		E. Air Shutter Setting	46
A. Appliance/Decorative Front Dimension Diagrams	8	10 Finishing	
B. Clearances to Combustibles	10	A. Facing Material	47
C. Constructing the Appliance Chase	12	B. Mantel and Wall Projections	48
4 Termination Location and Vent Information		C. Decorative Front Dimensions for Finishing	48
→ A. Vent Termination Minimum Clearances	13	11 Appliance Setup	
B. Vent Terminal Clearances	14	A. Remove the Packaging	49
C. Approved Pipe	15	B. Remove Fixed Glass Assembly	49
D. Use of Elbows	16	C. Remove the Shipping Materials	49
E. Measuring Standards	17	D. Remove Glass Media Package	49
F. Vent Diagrams	18	E. Clean the Appliance	49
5 Vent Clearances and Framing		F. Install Glass Media	50
A. Pipe Clearances to Combustibles	30	G. Install Fixed Glass Assembly	51
B. Wall Penetration Framing/Firestops	30	H. Install Decorative Front	51
C. Ceiling Firestop/Floor Penetration Framing	31	12 Reference Materials	
D. Install Attic Insulation Shield	31	A. Vent Components Diagrams	52
6 Appliance Preparation		B. Optional Components	61
A. Vent Collar Preparation	32	C. Accessories	62
B. Securing and Leveling the Appliance	34		

→ = Contains updated information.

Installation Standard Work Checklist

ATTENTION INSTALLER: Follow this Standard Work Checklist

This standard work checklist is to be used by the installer in conjunction with, not instead of, the instructions contained in this installation manual.

Customer: _____
Lot/Address: _____
Model (circle one): NEVO3630I-B NEVO4236I-B

Date Installed: _____
Location of Fireplace: _____
Installer: _____
Dealer/Distributor Phone # _____
Serial #: _____

 **WARNING! Risk of Fire or Explosion!** Failure to install appliance according to these instructions could lead to a fire or explosion.

Appliance Install	YES	IF NO, WHY?
Verified that the chase is insulated and sealed. (Pg. 12)	<input type="checkbox"/>	_____
Verified factory-installed non-combustible board is in place.	<input type="checkbox"/>	_____
Verified clearances to combustibles. (Pg. 10-11)	<input type="checkbox"/>	_____
Fireplace is leveled and secured. (Pg. 34)	<input type="checkbox"/>	_____
 Venting/Chimney Section 7 (Pg 35-41)		
Venting configuration complies to vent diagrams.	<input type="checkbox"/>	_____
Venting installed, locked and secured in place with proper clearance.	<input type="checkbox"/>	_____
Firestops installed.	<input type="checkbox"/>	_____
Attic insulation shield installed.	<input type="checkbox"/>	_____
Exterior wall/Roof flashing installed and sealed.	<input type="checkbox"/>	_____
Terminations installed and sealed.	<input type="checkbox"/>	_____
 Electrical Section 8 (Pg 42-44)		
Unswitched power (110-120 VAC) provided to the appliance.	<input type="checkbox"/>	_____
Switch wires properly installed.	<input type="checkbox"/>	_____
 Gas Section 9 (Pg 45-46)		
Proper appliance for fuel type.	<input type="checkbox"/>	_____
Was a conversion performed?	<input type="checkbox"/>	_____
Leak check performed and inlet pressure verified.	<input type="checkbox"/>	_____
Verified proper air shutter setting for installation type.	<input type="checkbox"/>	_____
 Finishing Section 10 (Pg 47-48)		
Combustible materials not installed in non-combustible areas.	<input type="checkbox"/>	_____
Verified all clearances meet installation manual requirements.	<input type="checkbox"/>	_____
Mantels and wall projections comply with installation manual requirements.	<input type="checkbox"/>	_____
 Appliance Setup Section 11 (Pg 49-51)		
All packaging and protective materials removed (inside & outside of appliance).	<input type="checkbox"/>	_____
Media installed correctly.	<input type="checkbox"/>	_____
Glass assembly installed and secured.	<input type="checkbox"/>	_____
Accessories installed properly.	<input type="checkbox"/>	_____
Decorative front properly installed.	<input type="checkbox"/>	_____
Manual bag and all of its contents are removed from inside/under the appliance and given to party responsible for use and operation.	<input type="checkbox"/>	_____
Started appliance and verified no gas leaks exist.	<input type="checkbox"/>	_____

Hearth & Home Technologies recommends the following:

- Photographing the installation and copying this checklist for your file.
- That this checklist remain visible at all times on the appliance until the installation is complete.

Comments: Further description of the issues, who is responsible (Installer/ Builder/ Other Trades, etc) and corrective action needed _____

Comments Communicated to party responsible _____ by _____ on _____
 (Builder / Gen. Contractor/) (Installer) (Date)

➔ = Contains updated information.

1 Product Specific and Important Safety Information

A. Appliance Certification

MODELS: NEVO4236I-B, NEVO3630I-B
LABORATORY: Underwriters Laboratories, Inc. (UL)
TYPE: Direct Vent Heater
STANDARD: ANSI Z21.88-2017 • CSA 2.33-2017

This product is listed to ANSI standards for “Vented Gas Fireplace Heaters” and applicable sections of “Gas Burning Heating Appliances for Manufactured Homes and Recreational Vehicles”, and “Gas Fired Appliances for Use at High Altitudes”.

NOTICE: This installation must conform with local codes. In the absence of local codes you must comply with the National Fuel Gas Code, ANSI Z223.1-latest edition in the U.S.A. and the CAN/CGA B149 Installation Codes in Canada.

NOT INTENDED FOR USE AS A PRIMARY HEAT SOURCE.
This appliance is tested and approved as either supplemental room heat or as a decorative appliance. It should not be factored as primary heat in residential heating calculations.

B. Glass Specifications

Hearth & Home Technologies appliances manufactured with tempered glass may be installed in hazardous locations such as bathtub enclosures as defined by the Consumer Product Safety Commission (CPSC). The tempered glass has been tested and certified to the requirements of **ANSI Z97.1** and **CPSC 16 CFR 1202** (Safety Glazing Certification Council **SGCC# 1595** and **1597**. Architectural Testing, Inc. Reports **02-31919.01** and **02-31917.01**).

This statement is in compliance with **CPSC 16 CFR Section 1201.5** “Certification and labeling requirements” which refers to **15 U.S. Code (USC) 2063** stating “...Such certificate shall accompany the product or shall otherwise be furnished to any distributor or retailer to whom the product is delivered.”

Some local building codes require the use of tempered glass with permanent marking in such locations. Glass meeting this requirement is available from the factory. Please contact your dealer or distributor to order.

C BTU Specifications

Models <i>(U.S. or Canada)</i>		Maximum Input BTU/h	Mini- mum Input BTU/h	Orifice Size (DMS)
NEVO3630I-B (NG)	<i>(0-2000 FT)</i>	20,000	10,000	0.083
NEVO3630I-B (Propane)	<i>(0-2000 FT)</i>	20,000	10,000	0.053
NEVO4236I-B (NG)	<i>(0-2000 FT)</i>	25,000	12,500	0.089 #43
NEVO4236I-B (Propane)	<i>(0-2000 FT)</i>	23,000	11,500	0.055 #54

D. High Altitude Installations

NOTICE: If the heating value of the gas has been reduced, these rules do not apply. Check with your local gas utility or authorities having jurisdiction.

When installing above 2000 feet elevation:

- In the USA: Reduce input rate 4% for each 1000 feet above 2000 feet.
- In CANADA: Input ratings are certified without a reduction of input rate for elevations up to 4500 feet (1370 m) above sea level. Please consult provincial and/or local authorities having jurisdiction for installations at elevations above 4500 feet (1370 m).

Check with your local gas utility to determine proper orifice size.

E. Non-Combustible Materials Specification

Material which will not ignite and burn. Such materials are those consisting entirely of steel, iron, brick, tile, concrete, slate, glass or plasters, or any combination thereof.

Materials that are reported as passing **ASTM E 136, Standard Test Method for Behavior of Materials in a Vertical Tube Furnace at 750 °C** shall be considered non-combustible materials.

F. Combustible Materials Specification

Materials made of or surfaced with wood, compressed paper, plant fibers, plastics, or other material that can ignite and burn, whether flame proofed or not, or plastered or unplastered shall be considered combustible materials.

G. Electrical Codes

NOTICE: *This appliance must be electrically wired and grounded in accordance with local codes or, in the absence of local codes, with **National Electric Code ANSI/NFPA 70-latest edition** or the **Canadian Electric Code CSA C22.1**.*

- A 110-120 VAC circuit for this product must be protected with ground-fault circuit-interrupter protection, in compliance with the applicable electrical codes, when it is installed in locations such as in bathrooms or near sinks.

H. California



WARNING: This product and the fuels used to operate this product (liquid propane or natural gas), and the products of combustion of such fuels, can expose you to chemicals including benzene, which is known to the State of California to cause cancer and reproductive harm. For more information go to: www.P65Warnings.ca.gov.

Note: The following requirements reference various Massachusetts and national codes not contained in this document.

I. Requirements for the Commonwealth of Massachusetts

For all side wall horizontally vented gas fueled equipment installed in every dwelling, building or structure used in whole or in part for residential purposes, including those owned or operated by the Commonwealth and where the side wall exhaust vent termination is less than seven (7) feet above finished grade in the area of the venting, including but not limited to decks and porches, the following requirements shall be satisfied:

Installation of Carbon Monoxide Detectors

At the time of installation of the side wall horizontal vented gas fueled equipment, the installing plumber or gas fitter shall observe that a hard wired carbon monoxide detector with an alarm and battery back-up is installed on the floor level where the gas equipment is to be installed. In addition, the installing plumber or gas fitter shall observe that a battery operated or hard wired carbon monoxide detector with an alarm is installed on each additional level of the dwelling, building or structure served by the side wall horizontal vented gas fueled equipment. It shall be the responsibility of the property owner to secure the services of qualified licensed professionals for the installation of hard wired carbon monoxide detectors.

In the event that the side wall horizontally vented gas fueled equipment is installed in a crawl space or an attic, the hard wired carbon monoxide detector with alarm and battery back-up may be installed on the next adjacent floor level.

In the event that the requirements of this subdivision can not be met at the time of completion of installation, the owner shall have a period of thirty (30) days to comply with the above requirements; provided, however, that during said thirty (30) day period, a battery operated carbon monoxide detector with an alarm shall be installed.

Approved Carbon Monoxide Detectors

Each carbon monoxide detector as required in accordance with the above provisions shall comply with NFPA 720 and be ANSI/UL 2034 listed and IAS certified.

Signage

A metal or plastic identification plate shall be permanently mounted to the exterior of the building at a minimum height of eight (8) feet above grade directly in line with the exhaust vent terminal for the horizontally vented gas fueled heating appliance or equipment. The sign shall read, in print size no less than one-half (1/2) in. in size, "**GAS VENT DIRECTLY BELOW. KEEP CLEAR OF ALL OBSTRUCTIONS**".

Inspection

The state or local gas inspector of the side wall horizontally vented gas fueled equipment shall not approve the installation unless, upon inspection, the inspector observes carbon monoxide detectors and signage installed in accordance with the provisions of 248 CMR 5.08(2)(a)1 through 4.

Exemptions

The following equipment is exempt from 248 CMR 5.08(2)(a)1 through 4:

- The equipment listed in Chapter 10 entitled "Equipment Not Required To Be Vented" in the most current edition of NFPA 54 as adopted by the Board; and
- Product Approved side wall horizontally vented gas fueled equipment installed in a room or structure separate from the dwelling, building or structure used in whole or in part for residential purposes.

MANUFACTURER REQUIREMENTS

Gas Equipment Venting System Provided

When the manufacturer of Product Approved side wall horizontally vented gas equipment provides a venting system design or venting system components with the equipment, the instructions provided by the manufacturer for installation of the equipment and the venting system shall include:

- Detailed instructions for the installation of the venting system design or the venting system components; and
- A complete parts list for the venting system design or venting system.

Gas Equipment Venting System NOT Provided

When the manufacturer of a Product Approved side wall horizontally vented gas fueled equipment does not provide the parts for venting the flue gases, but identifies "special venting systems", the following requirements shall be satisfied by the manufacturer:

- The referenced "special venting system" instructions shall be included with the appliance or equipment installation instructions; and
- The "special venting systems" shall be Product Approved by the Board, and the instructions for that system shall include a parts list and detailed installation instructions.

A copy of all installation instructions for all Product Approved side wall horizontally vented gas fueled equipment, all venting instructions, all parts lists for venting instructions, and/or all venting design instructions shall remain with the appliance or equipment at the completion of the installation.

See Gas Connection section for additional Commonwealth of Massachusetts requirements.

2 Getting Started

A. Design and Installation Considerations

Heatilator direct vent gas appliances are designed to operate with all combustion air siphoned from outside of the building and all exhaust gases expelled to the outside. No additional outside air source is required.

Installation **MUST** comply with local, regional, state and national codes and regulations. Consult insurance carrier, local building inspector, fire officials or authorities having jurisdiction over restrictions, installation inspection and permits.

Before installing, determine the following:

- Where the appliance is to be installed.
- The vent system configuration to be used.
- Gas supply piping requirements.
- Electrical wiring requirements.
- Framing and finishing details.
- Whether optional accessories—devices such as a fan, wall switch, or remote control—are desired.

Installation and service of this appliance should be performed by qualified personnel. Hearth & Home Technologies recommends HHT Factory Trained or NFI certified professionals.



Improper installation, adjustment, alteration, service or maintenance can cause injury or property damage. For assistance or additional information, consult a qualified service technician, service agency or your dealer.

B. Wall Surface/TV Guidelines

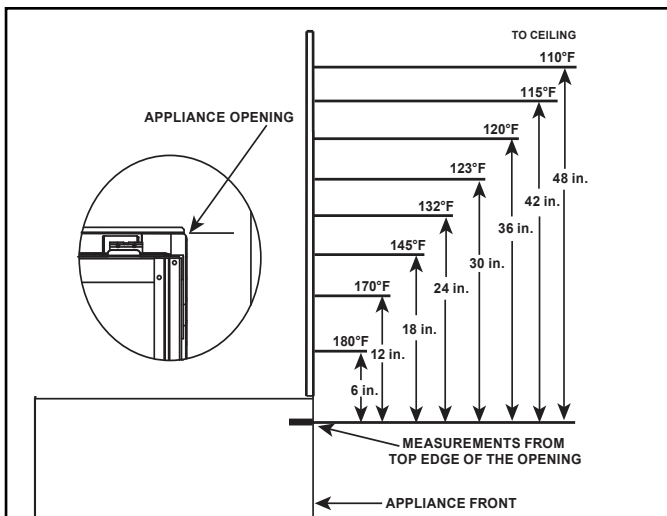

Figure 2.1. Maximum Wall Surface Temperatures Above Appliance

NOTICE: Temperatures listed above are taken with a temperature measuring probe as prescribed by the test standard used for appliance certification. Temperatures on walls or mantels taken with an infrared thermometer may yield increased temperatures of up to 30 degrees or more depending on the thermometer settings and material characteristics being measured.

C. Tools and Supplies Needed

Before beginning the installation be sure that the following tools and building supplies are available.

Tape measure	Framing material
Pliers	Hammer
Phillips screwdriver	Manometer
Gloves	Framing square
Voltmeter	Electric drill and bits (1/4 in.)
Plumb line	Safety glasses
Level	Reciprocating saw

Flat blade screwdriver

Non-corrosive leak check solution

1/2 - 3/4 in. length, #6 or #8 Self-drilling screws

Caulking material (300 °F minimum continuous exposure rating)

One 1/4 in. female connection (for optional fan).

D. Inspect Appliance and Components

- Carefully remove the appliance and components from the packaging.
- The vent system components and decorative doors and fronts may be shipped in separate packages.
- If packaged separately, the log set and appliance grate must be installed.
- Report to your dealer any parts damaged in shipment, particularly the condition of the glass.
- **Read all of the instructions before starting the installation. Follow these instructions carefully during the installation to ensure maximum safety and benefit.**

WARNING! Risk of Fire or Explosion! Damaged parts could impair safe operation. DO NOT install damaged, incomplete or substitute components. Keep appliance dry.

Hearth & Home Technologies disclaims any responsibility for, and the warranty will be voided by, the following actions:

- Installation and use of any damaged appliance or vent system component.
- Modification of the appliance or vent system.
- Installation other than as instructed by Hearth & Home Technologies.
- Improper positioning of the gas logs or the glass door.
- Installation and/or use of any component part not approved by Hearth & Home Technologies.

Any such action may cause a fire hazard.

WARNING! Risk of Fire, Explosion or Electric Shock! DO NOT use this appliance if any part has been under water. Call a qualified service technician to inspect the appliance and to replace any part of the control system and/or gas control which has been under water.

3 Framing and Clearances

A. Appliance/Decorative Front Dimension Diagrams

Dimensions are actual appliance dimensions. Use for reference only. For framing dimensions and clearances refer to Section 5.

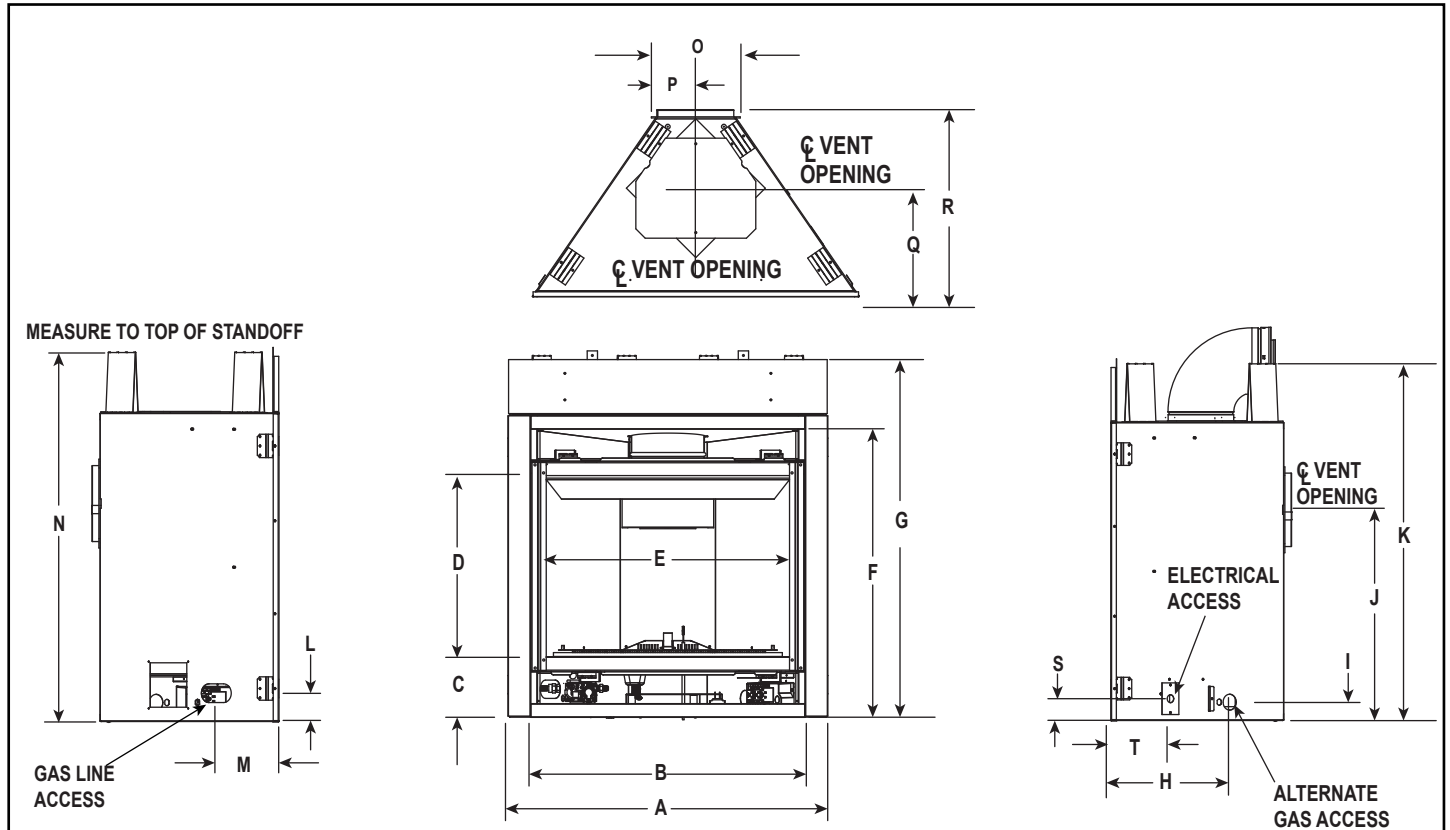

Appliance Dimensions Table

Location	NEVO3630I-B		NEVO4236I-B	
	Inches	Millimeters	Inches	Millimeters
A	35	889	41	1041
B	30	762	36	914
C	6-3/8	162	6-3/8	162
D	19-7/8	505	19-7/8	505
E	26-5/8	676	32-5/8	829
F	31-1/2	800	31-1/2	800
G	39-1/8	994	39-1/8	994
H	15-3/4	400	15-3/4	400
I	1-3/4	44	1-3/4	44
J	23-1/2	597	23-1/2	597
K	39-1/2	1003	39-1/2	1003
L	3	76	3	76
M	6-1/2	165	6-1/2	165
N	39-5/8	1007	39-5/8	1007
O	8-5/8	219	14-5/8	371
P	4-3/8	111	7-3/8	186
Q	11-5/8	295	11-5/8	295
R	19-1/8	486	19-1/8	486
S	2-3/8	60	2-3/8	60
T	8	203	8	203

Figure 3.1 Appliance Dimensions

DF-MR30/DF-MR30-SS DECORATIVE FRONTS

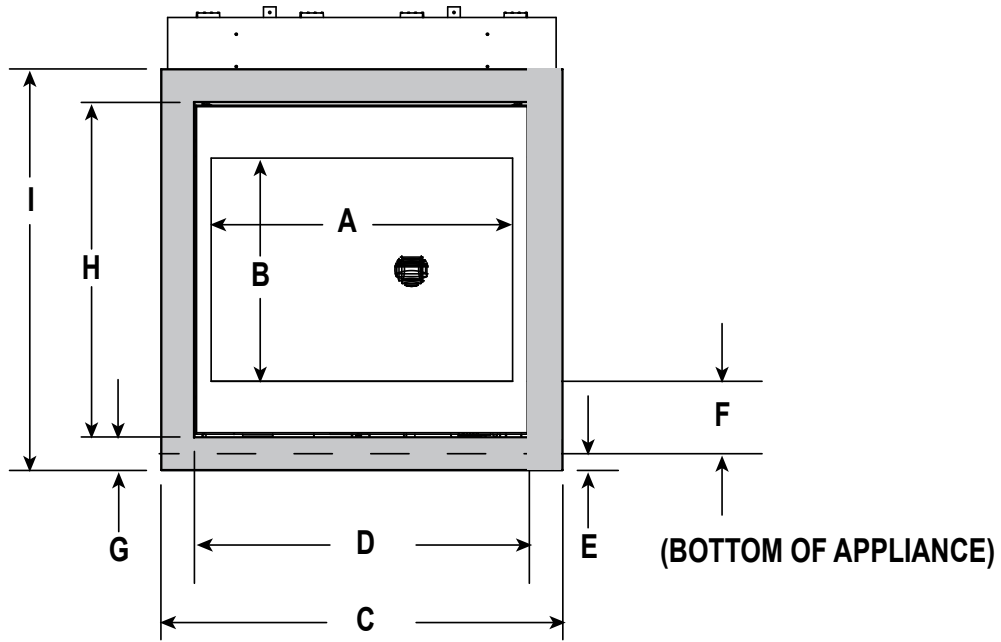

		A	B	C	D	E	F	G	H	I
NEVO3630i	in.	27	20	36	30	1-1/2	6-1/2	3	30	36
	mm	686	508	914	762	38	165	76	762	914

DF-MR36/DF-MR36-SS DECORATIVE FRONTS

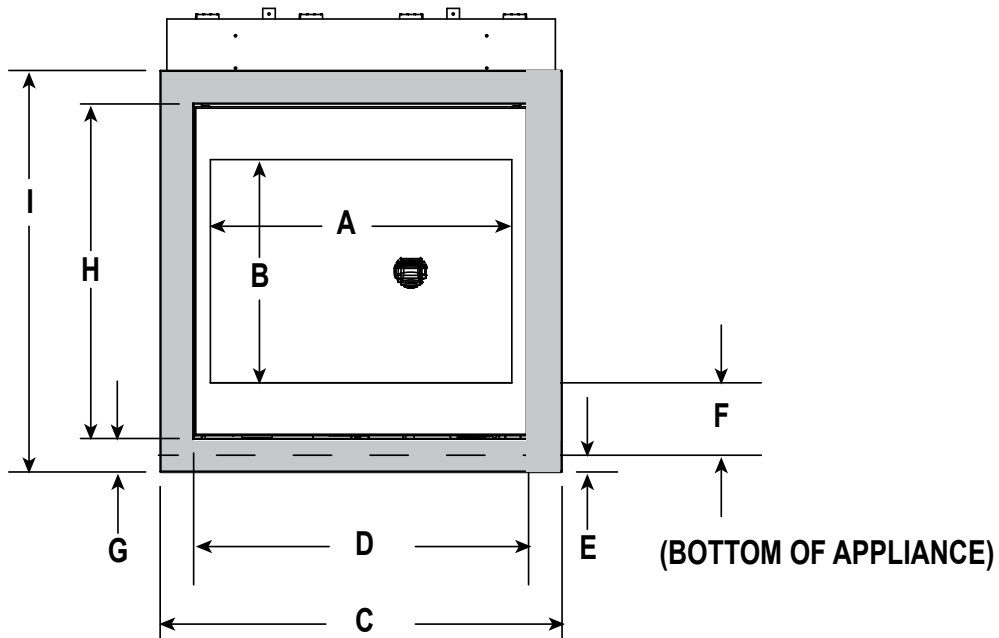

		A	B	C	D	E	F	G	H	I
NEVO4236i	in.	33	20	42	36	1-1/2	6-1/2	3	30	36
	mm	838	508	1067	914	38	165	76	762	914

Figure 3.2 Decorative Front Dimensions (Including Surround)

B. Clearances to Combustibles

When selecting a location for the appliance it is important to consider the required clearances to walls (see Figure 3.3).

WARNING! Risk of Fire or Burns! Provide adequate clearance around air openings and for service access. Due to high temperatures, the appliance should be located out of traffic and away from furniture and draperies.

NOTICE: Illustrations reflect typical installations and are FOR DESIGN PURPOSES ONLY. Illustrations/diagrams are not drawn to scale. Actual installation may vary due to individual design preference.

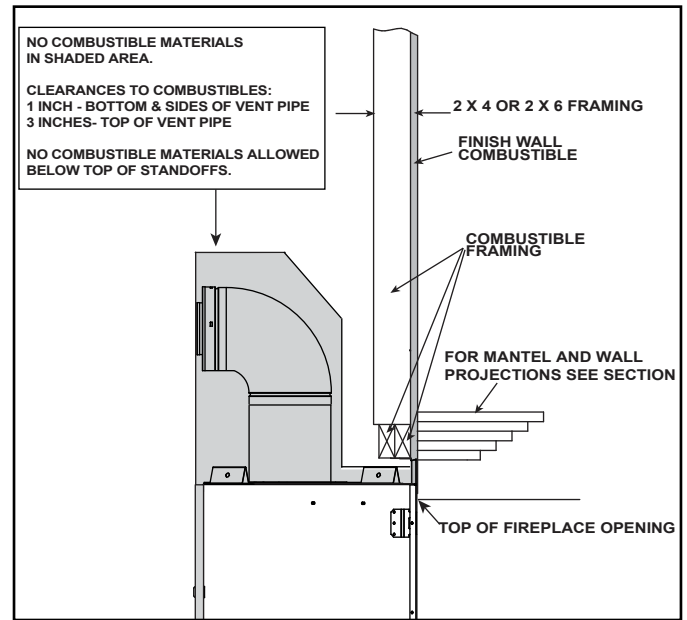

Figure 3.4 Clearances to Combustibles - Non-Combustible Zone

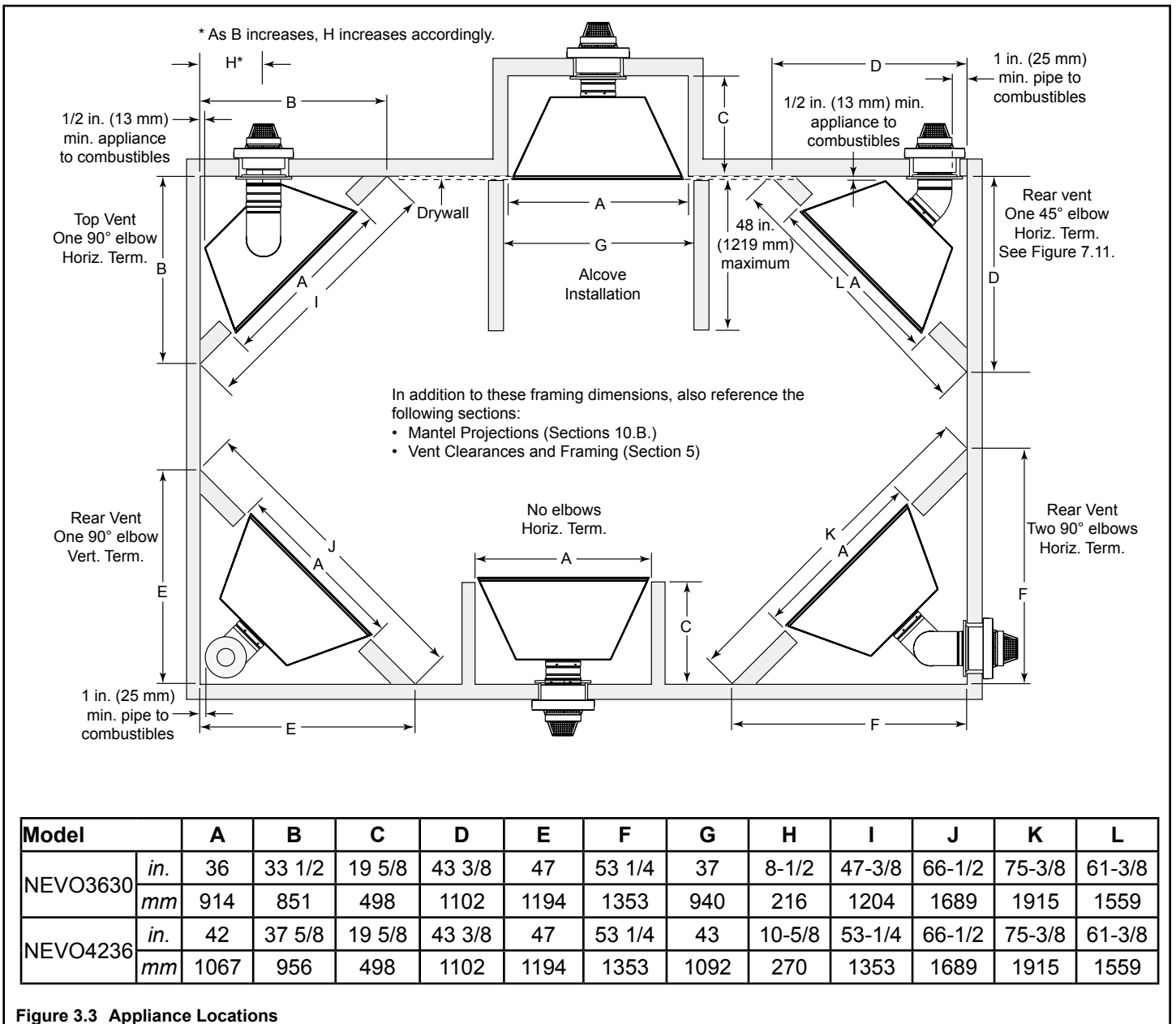
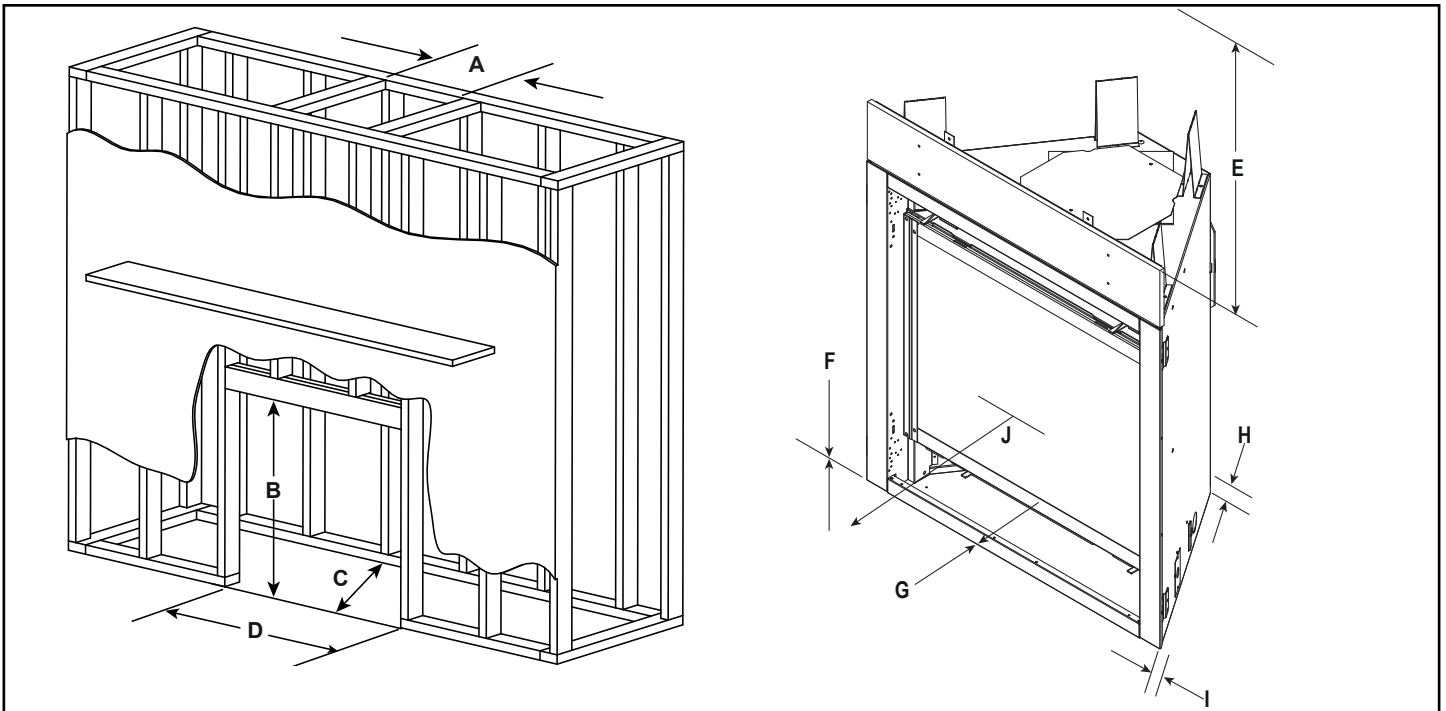

Figure 3.3 Appliance Locations



*** MINIMUM FRAMING DIMENSIONS**

		A	B	C**	D	E	F	G	H	I	J
		Rough Opening (Vent Pipe)	Rough Opening (Height)	Rough Opening (Depth)	Rough Opening (Width)	Clearance to Ceiling	Combustible Floor	Combustible Flooring	Behind Appliance	Sides of Appliance	Front of Appliance
NEVO3630I-B	in.	10	39-7/8	19-5/8	36	30	0	0	1/2	1/2	36
	mm	254	1013	499	914	762	0	0	13	13	914
NEVO4236I-B	in.	10	39-7/8	19-5/8	42	30	0	0	1/2	1/2	36
	mm	254	1013	499	1067	762	0	0	13	13	914

* Adjust framing dimensions for interior sheathing (such as sheetrock)

C** Add 11-1/2 inches for rear vented elbow vented directly off the rear of the appliance.

Figure 3.5 Clearances to Combustibles

C. Constructing the Appliance Chase

A chase is a vertical box-like structure built to enclose the gas appliance and/or its vent system. In cooler climates the vent should be enclosed inside the chase.

NOTICE: *Treatment of ceiling firestops and wall shield firestops and construction of the chase may vary with the type of building. These instructions are not substitutes for the requirements of local building codes. Therefore, you MUST check local building codes to determine the requirements to these steps.*

NOTICE: *When installing a sprinkler head in a fireplace chase, it is recommended to use a sprinkler head with a sprinkler activation temperature classified as Extra High. Keep sprinkler head away from vent and chimney.*

Chases should be constructed in the manner of all outside walls of the home to prevent cold air drafting problems. The chase should not break the outside building envelope in any manner.

Walls, ceiling, base plate and cantilever floor of the chase should be insulated. Vapor and air infiltration barriers should be installed in the chase as per regional codes for the rest of the home. Additionally, in regions where cold air infiltration may be an issue, the inside surfaces may be sheetrocked and taped (or an equivalent method may be used) to achieve maximum air tightness.

To further prevent drafts, the wall shield and ceiling firestops should be caulked with caulk with a minimum of 300 °F continuous exposure rating to seal gaps. Gas line holes and other openings should be caulked with caulk with a minimum of 300 °F continuous exposure rating or stuffed with unfaced insulation. If the appliance is being installed on a cement surface, a layer of plywood may be placed underneath to prevent conducting cold up into the room.

NOTICE: *Install appliance on hard metal or wood surfaces extending full width and depth. **DO NOT** install directly on carpeting, vinyl, tile or any combustible material other than wood.*

WARNING! Risk of Fire! *Maintain specified air space clearances to appliance and vent pipe:*

- Insulation and other materials must be secured to prevent accidental contact.
- The chase must be properly blocked to prevent blown insulation or other combustibles from entering and making contact with fireplace or chimney.
- Failure to maintain airspace may cause overheating and a fire.

4 Termination Location and Vent Information

A. Vent Termination Minimum Clearances

WARNING

Fire Risk.
 Maintain vent clearance to combustibles as specified.

- **DO NOT** pack air space with insulation or other materials.

Failure to keep insulation or other materials away from vent pipe could cause overheating and fire.

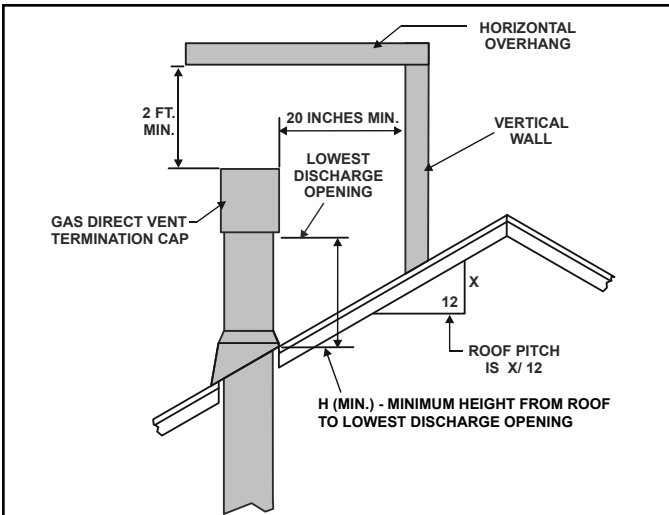

Roof Pitch	H (Min.) Ft.
Flat to 6/12.....	1.0*
Over 6/12 to 7/12.....	1.25*
Over 7/12 to 8/12.....	1.5*
Over 8/12 to 9/12.....	2.0*
Over 9/12 to 10/12.....	2.5*
Over 10/12 to 11/12.....	3.25
Over 11/12 to 12/12.....	4.0
Over 12/12 to 14/12.....	5.0
Over 14/12 to 16/12.....	6.0
Over 16/12 to 18/12.....	7.0
Over 18/12 to 20/12.....	7.5
Over 20/12 to 21/12.....	8.0

* H minimum may vary depending on regional snowfall. Refer to local codes.

Figure 4.1 Minimum Height From Roof to Lowest Discharge Opening

A	B
6 in. (minimum) up to 20 in. 152 mm/508 mm	18 in. minimum 457 mm
20 in. and over	0 in. minimum

C = 8 in. (203 mm) recommended

* If using decorative cap cover(s), this distance may need to be increased. Refer to the installation instructions supplied with the decorative cap cover.

** In a staggered installation with both gas and wood or fuel oil terminations, the wood or fuel oil termination cap must be higher than the gas termination cap.

Figure 4.2 Staggered Termination Caps

CAUTION! Risk of Burns! Termination caps are HOT, ← consider proximity to doors, traffic areas or where people may pass or gather (sidewalk, deck, patio, etc.). Listed cap shields available. Contact your dealer.

- Local codes or regulations may require different clearances.
- Hearth & Home Technologies assumes no responsibility for the improper performance of the appliance when the venting system does not meet these requirements.
- Vinyl protection kits are suggested for use with vinyl siding.
- Measure horizontal and vertical termination cap clearances as noted in Figure 4.3.

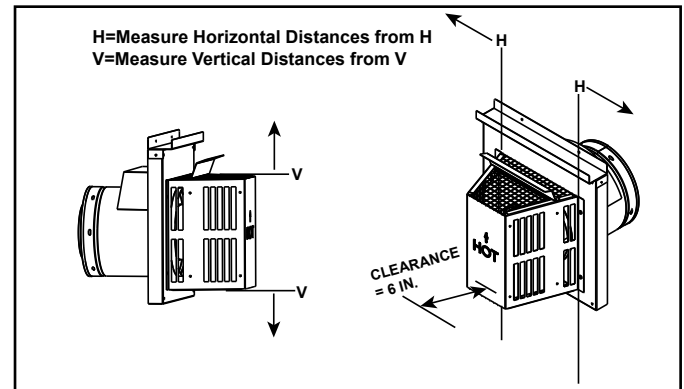
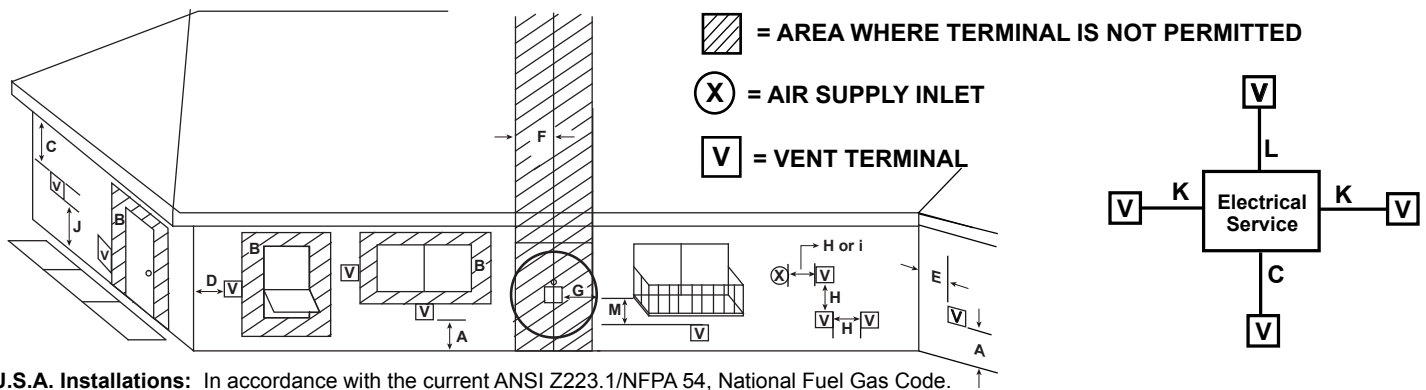

Figure 4.3

B. Vent Terminal Clearances



U.S.A. Installations: In accordance with the current ANSI Z223.1/NFPA 54, National Fuel Gas Code.

Canadian Installations: In accordance with the current CSA B149.1, Natural Gas and Propane Installation Code.

		U.S.A.	CANADA
A	Clearance above grade, veranda, porch, deck, or balcony	12 in. (305 mm)	12 in. (305 mm)
B	Clearance to window or door that may be opened, or to permanently closed window U.S.A.: = 9 in. min. (229 mm min.) CANADA: = 12 in. min. (305 mm min.)		
C	clearance below unventilated soffit	12 in. (305 mm)	12 in. (305 mm)
	clearance below ventilated soffit	18 in. (457 mm)	18 in. (457 mm)
	clearance below any vinyl soffits and electrical service	30 in. (762 mm)	30 in. (762 mm)
D	clearance to outside corner	6 in. (152 mm)	6 in. (152 mm)
E	clearance to inside corner	6 in. (152 mm)	6 in. (152 mm)
F	not to be installed above a gas meter/regulator assembly within 3 feet horizontally from the center-line of the regulator	3 ft (914 mm)	3 ft (914 mm)
G	clearance to gas service regulator vent outlet	3 ft (914 mm)	3 ft (914 mm)
H	clearance to non-mechanical air supply inlet to building or the combustion air inlet to any other appliance termination (mechanical or non-mechanical)	9 in. min. (229 mm min.)	12 in. min. (305 mm min.)
I	clearance to a mechanical (powered) air supply inlet *** (All mechanical air intakes within 10 feet of a horizontal termination cap must be a minimum of 3 feet below termination.)	3 ft (914 mm)***	6 ft (1.8 m)
J	On public property: clearance above paved sidewalk or a paved driveway.	7 ft (2.1 m)	7 ft (2.1 m)**
	** (A vent shall not terminate directly above a sidewalk or paved driveway which is located between two single family dwellings and serves both dwellings.)		
K	clearance from sides of electrical service	6 in. (152 mm)	6 in. (152 mm)
	Location of the vent termination must not interfere with access to the electrical service.		
L	clearance above electrical service	12 in. (305 mm)	12 in. (305 mm)
	Location of the vent termination must not interfere with access to the electrical service.		
M	clearance under veranda, porch, deck, balcony or overhang *(Permitted only if veranda, porch, deck, or balcony is fully open on a minimum of two sides beneath the floor.)	12 in. (305 mm)	12 in. (305 mm)*
	vinyl or composite overhang	30 in. (762 mm)	30 in. (762 mm)

Figure 4.4 Minimum Clearances for Termination

C. Approved Pipe

This appliance is approved for use with Hearth & Home Technologies DVP or SLP venting systems. Refer to Section 12.A for vent component information and dimensions.

DO NOT mix pipe, fittings or joining methods from different manufacturers.

The pipe is tested to be run inside an enclosed wall. There is no requirement for inspection openings at each joint within the wall.

WARNING! Risk of Fire or Asphyxiation. *This appliance requires a separate vent. DO NOT vent to a pipe serving a separate solid fuel burning appliance.*

D. Use of Elbows

Diagonal runs have both vertical and horizontal vent aspects when calculating the effects. Use the rise for the vertical aspect and the run for the horizontal aspect. See Figure 4.5.

Two 45° elbows may be used in place of one 90° elbow. On 45° runs, one foot of diagonal is equal to 8-1/2 in. (216 mm) horizontal run and 8-1/2 in. (216 mm) vertical run. A length of straight pipe is allowed between two 45° elbows. See Figure 4.5.

Figure 4.6 shows the vertical and horizontal offsets for DVP or SLP elbows.

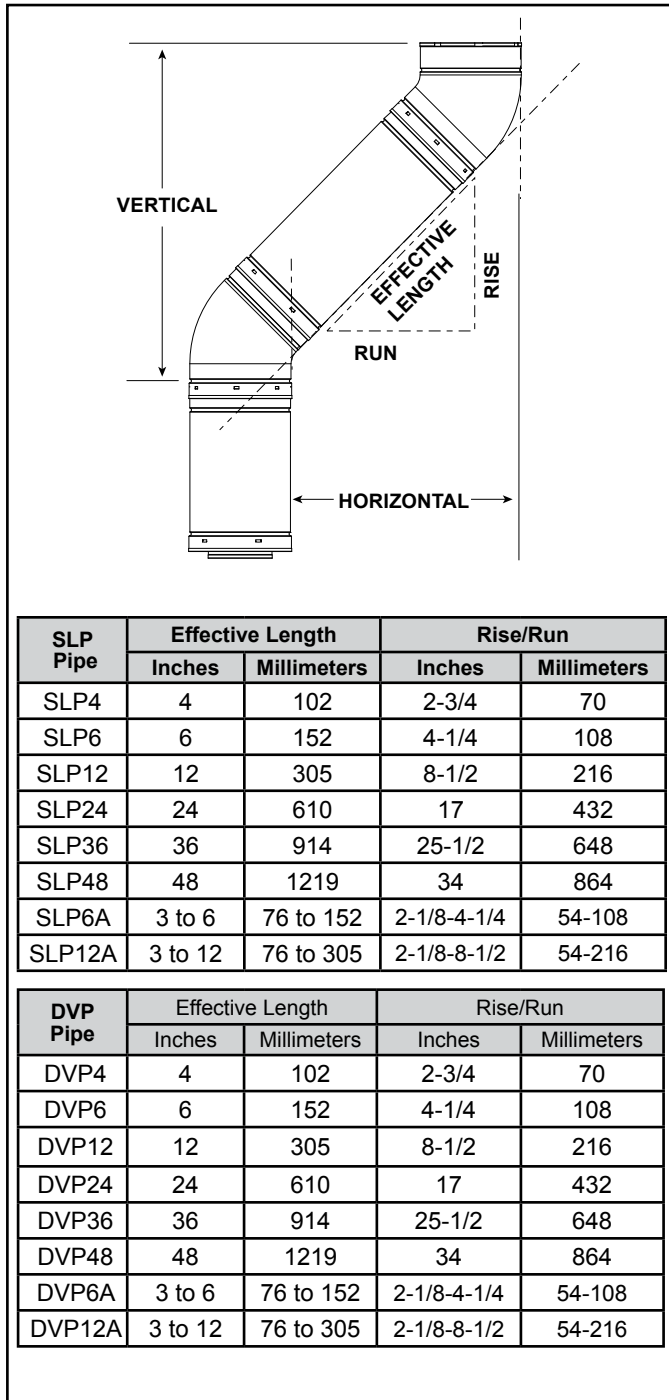

Figure 4.5

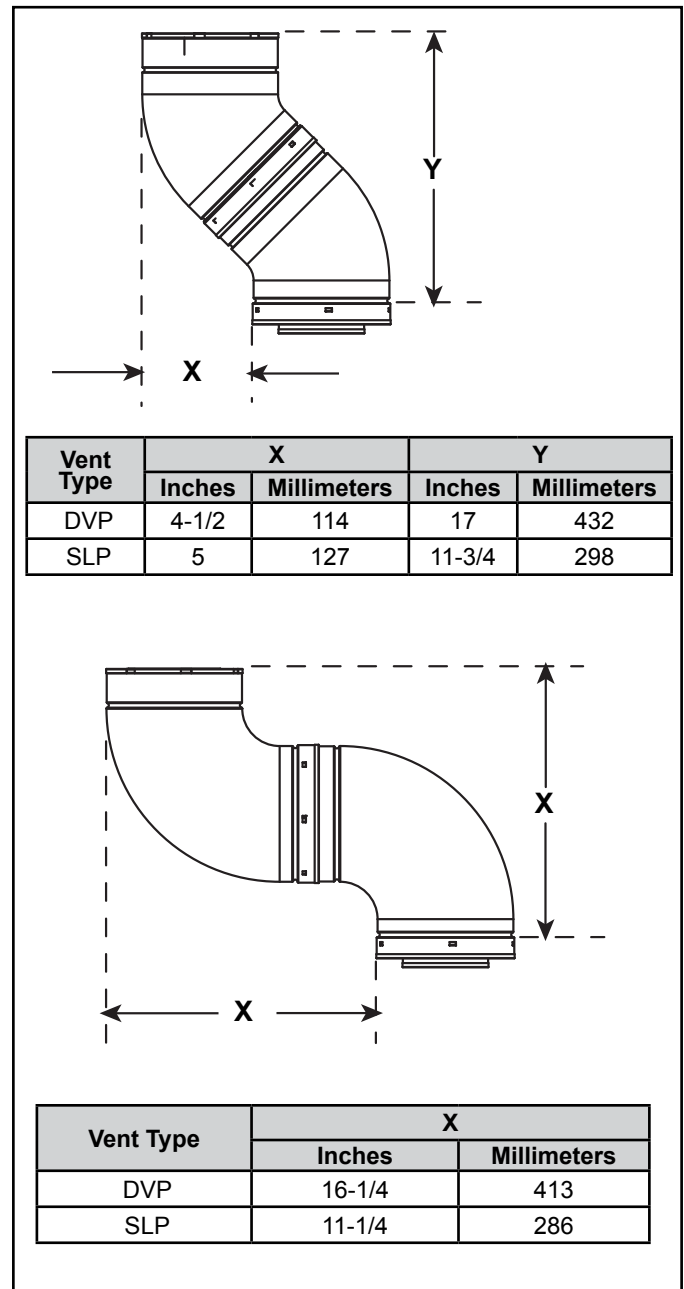

Figure 4.6 Vertical and Horizontal Offset for DVP and SLP Elbows

Note: Back to back 45 degree or 90 degree elbows have no additional vertical or horizontal value and are not included in determining maximum vent run lengths.

E. Measuring Standards

Vertical and horizontal measurements listed in the vent diagrams were made using the following standards:

- Pipe measurements are shown using the effective length of pipe. See Section 12.A (Figure 12.1 for DVP, Figure 12.7 for SLP) for information on effective length of pipe components.
- Horizontal terminations are measured to the outside mounting surface (flange of termination cap) (see Figure 4.7).
- Vertical terminations are measured to top of last section of pipe. See Figure 4.8.
- Horizontal pipe installed level with no rise.

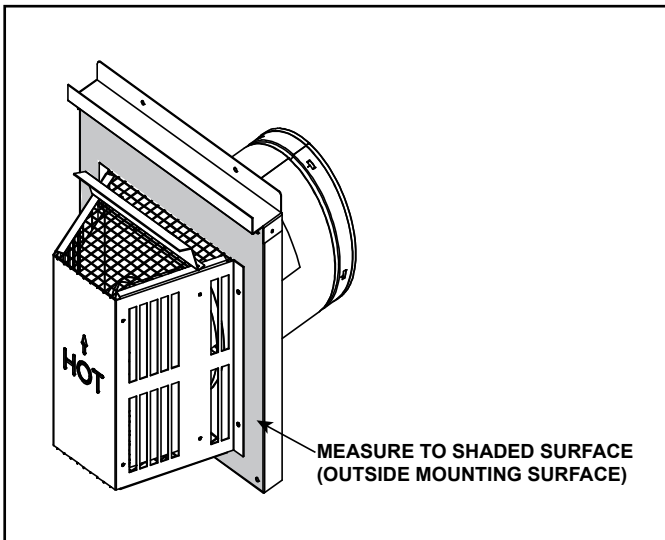

Figure 4.7 Measure to Outside Mounting Surface

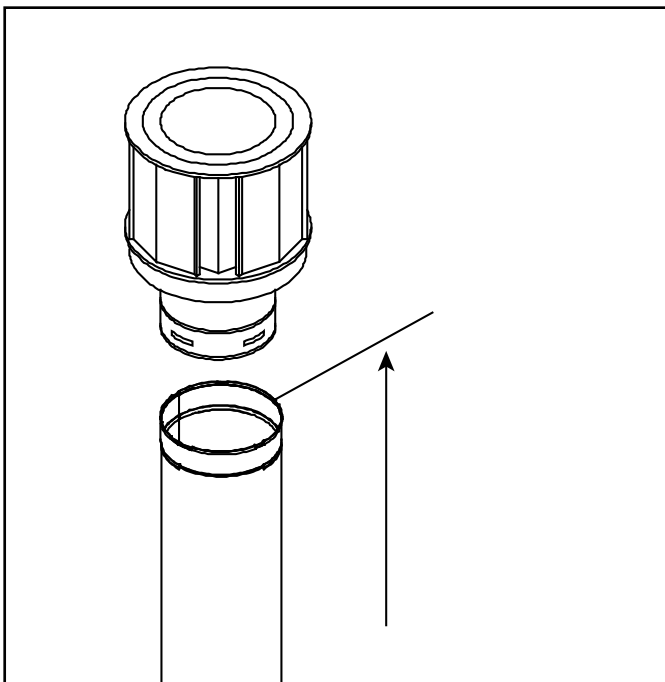

Figure 4.8 Measure to Top of Last Section of Pipe

F. Vent Diagrams

General Rules:

- SUBTRACT 3 ft. from the total H measurement for each 90° elbow installed horizontally.
- SUBTRACT 1-1/2 ft. from the total H measurement for each 45° elbow installed horizontally.
- A maximum of three 90° elbows (or six 45° elbows) may be used in any vent configuration. Some elbows may be installed horizontally.
- Elbows may be placed back to back anywhere in the system.
- Any 90° elbow may be replaced with two back to back 45° elbows.
- When penetrating a combustible wall, a wall shield firestop must be installed.
- When penetrating a combustible ceiling, a ceiling firestop must be installed.
- Horizontal runs of vent do not require vertical rise; horizontal runs may be level.
- Horizontal termination cap should have a 1/4 inch downward slant to allow any moisture in cap to be released. See Figure 4.9. See Figure 4.10 for additional water infiltration prevention information.

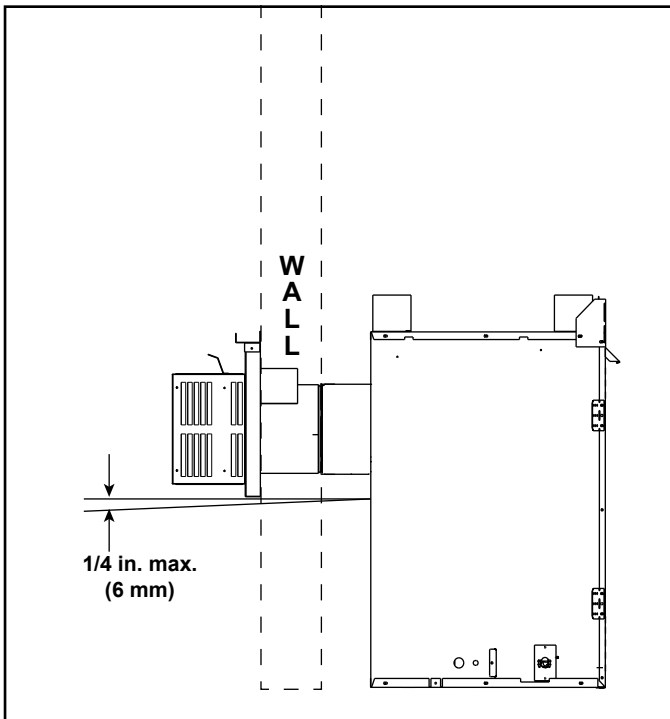

Figure 4.9 Water infiltration Prevention

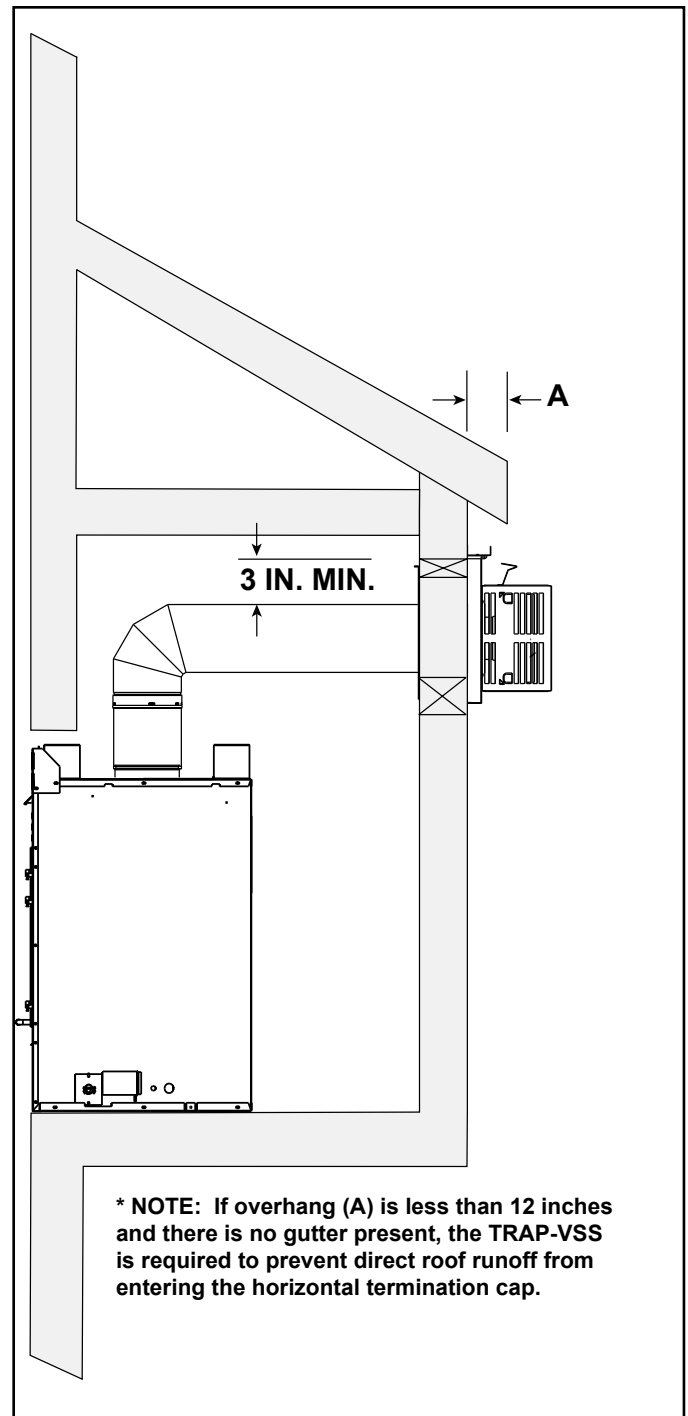

Figure 4.10 Exterior Chase - Water infiltration Prevention

Top Vent - Horizontal Termination - (continued)

Note: The Nevo series appliances can adapt to SLP series vent pipe when venting off the top of the appliance. You must use a DVP-SLP24 adapter or a DVP-2SL and two feet of SLP pipe which can only be attached to the appliance starting collar.

On horizontal terminations, the adapter is not counted as part of the minimum vertical (V_1 min.) requirements.

On both horizontal and vertical terminations, the adapter is counted as part of the maximum vertical limitations.

All venting rules for the vent run must still be followed.

Top Vent - Horizontal Termination

Top Vent—Horizontal Termination—Two 45° Elbows
Installation requirements to replace the first 90° elbow with two 45° elbows:

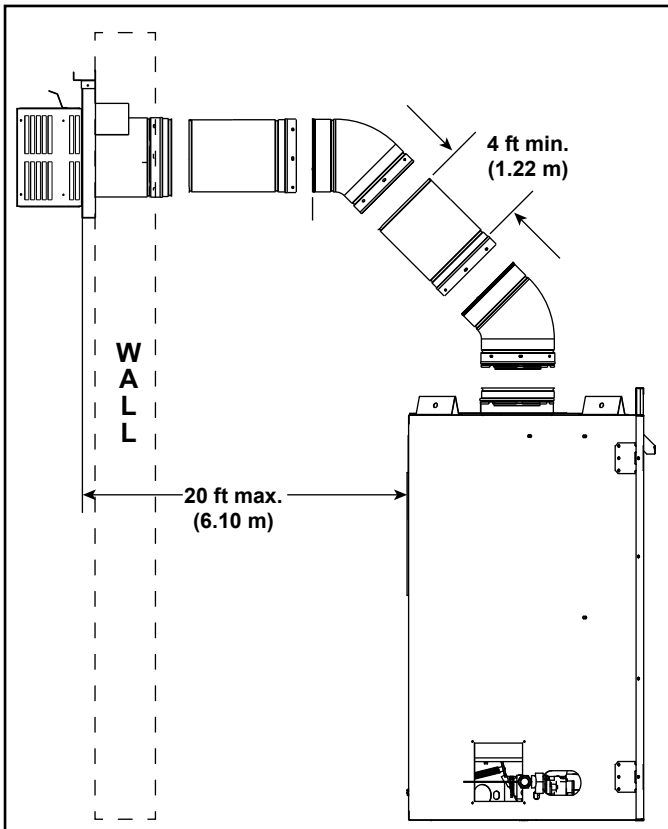

Figure 4.11 Minimum Installation Requirements for Two 45 Degree Elbows - Top Vent - Horizontal Termination

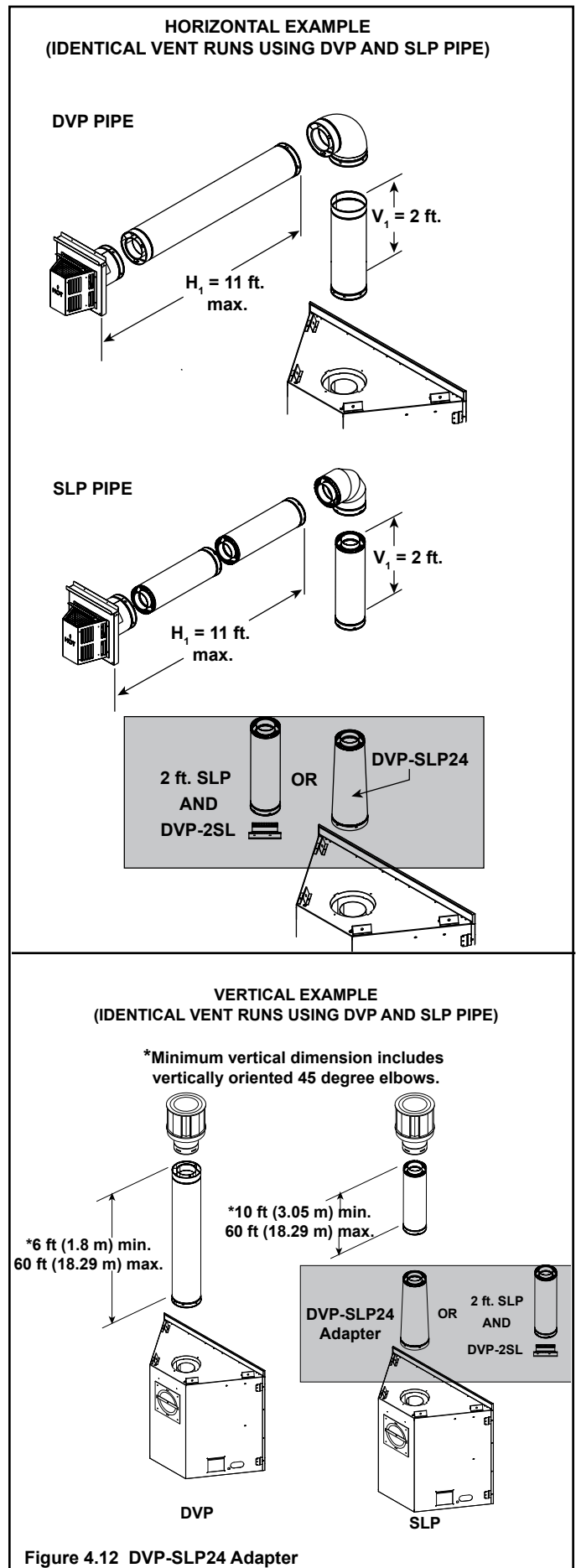
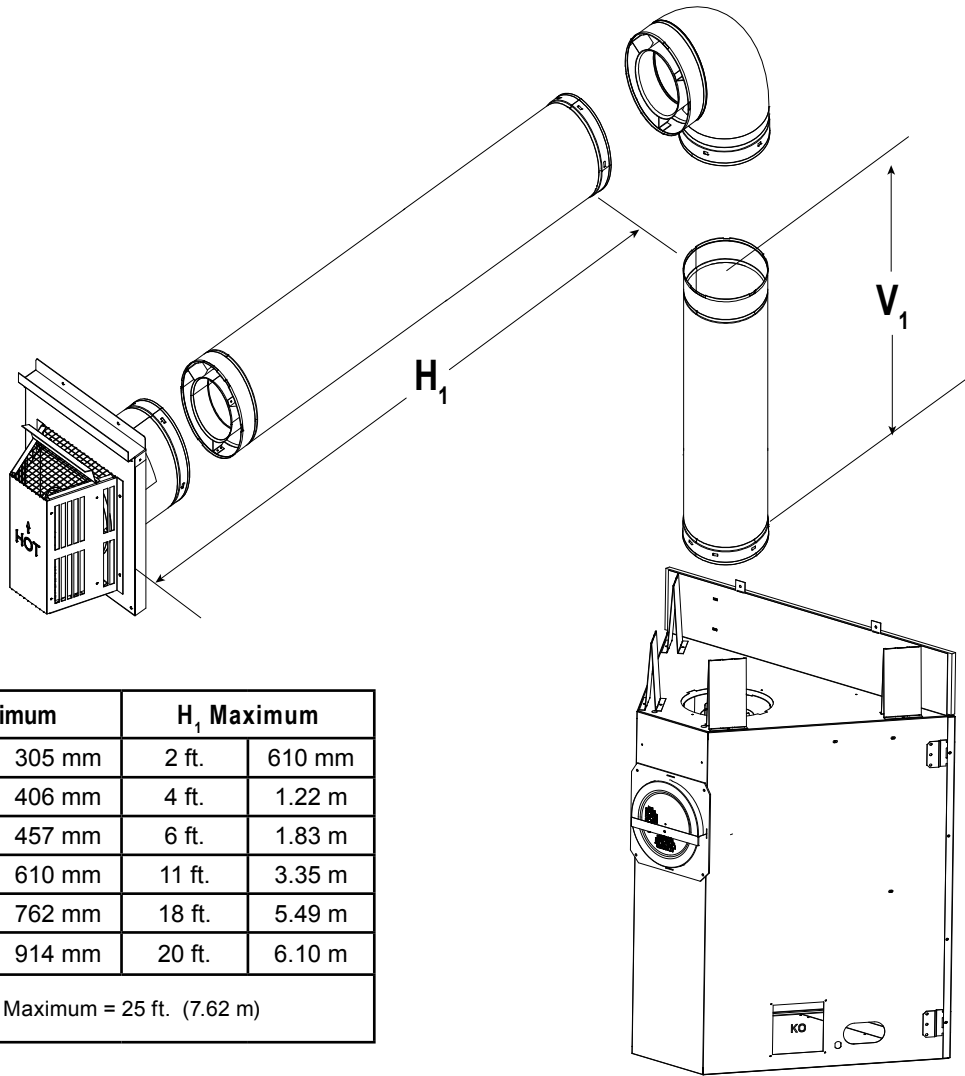

Figure 4.12 DVP-SLP24 Adapter

Top Vent - Horizontal Termination - (continued)

One Elbow



V_1 Minimum		H_1 Maximum	
1 ft.	305 mm	2 ft.	610 mm
16 in.	406 mm	4 ft.	1.22 m
18 in.	457 mm	6 ft.	1.83 m
2 ft.	610 mm	11 ft.	3.35 m
30 in.	762 mm	18 ft.	5.49 m
3 ft.	914 mm	20 ft.	6.10 m
V Maximum = 25 ft. (7.62 m)			

Figure 4.13

Top Vent - Horizontal Termination - (continued)

Two or Three Elbows

V ₁ Minimum		H ₁ + H ₂ Maximum		H ₁ + H ₂ + H ₃ Maximum	
18 in.	457 mm	6 ft.	1.83 m	3 ft.	.91 m
2 ft.	610 mm	11 ft.	3.35 m	8 ft.	2.4 m
30 in.	762 mm	18 ft.	5.49 m	15 ft.	4.6 m
3 ft.	914 mm	20 ft.	6.1 m	17 ft.	5.2 m
-	-	25 ft.	7.62 m	22 ft.	6.7 m
V Maximum = 25 ft. (7.62 m)					

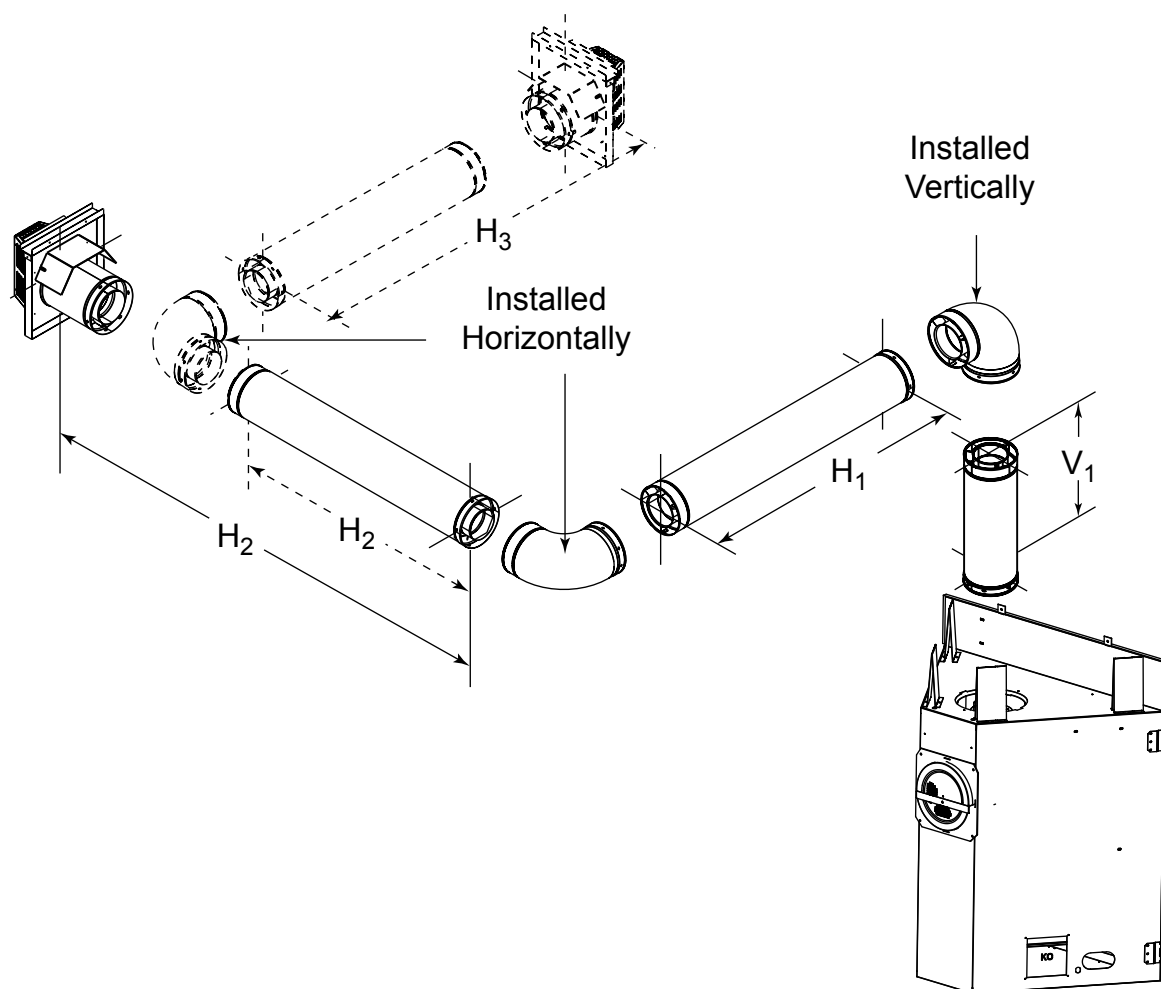

Figure 4.14

Three Elbows

V_1 min.		V_1+V_2 max.		H_1+H_2 max.	
2 ft.	610 mm	25 ft.	7.62 m	20 ft.	6.1 m

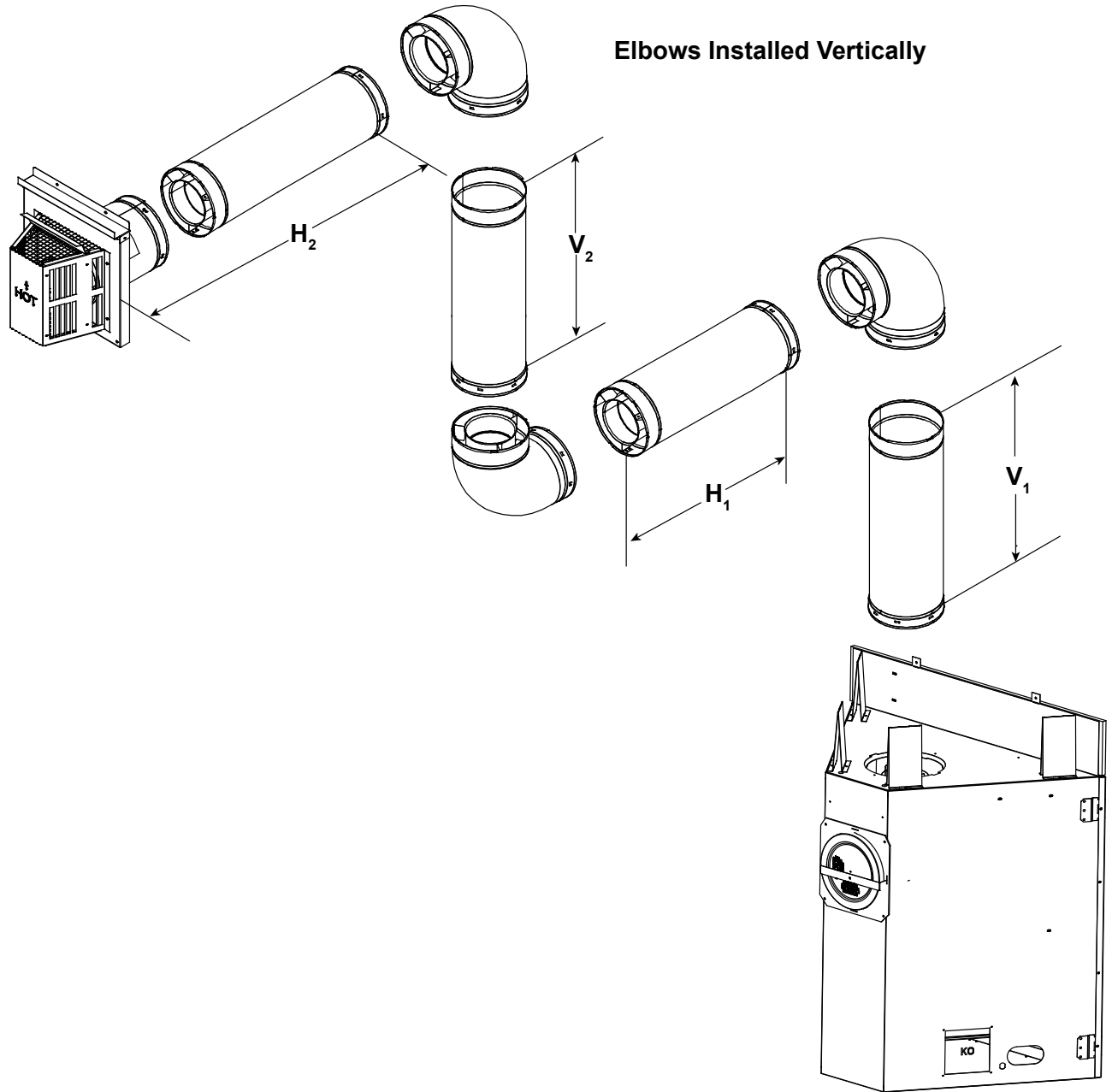

Figure 4.15

Install Top Vent Flue Visor - No Elbow Configurations

- Remove screws holding flue visor to firebox top. See Figure 4.16.
- Remove the flue visor.
- Using the screws removed and the same holes, install the top vent flue baffle and flue visor.
 - The top vent flue baffle will be turned to install below the level of the firebox top for 12-30 ft vertical runs of vent. See Figure 4.17.
 - The top vent flue baffle will be turned to install inside for 31-60 ft. vertical runs of vent. See Figure 4.18.

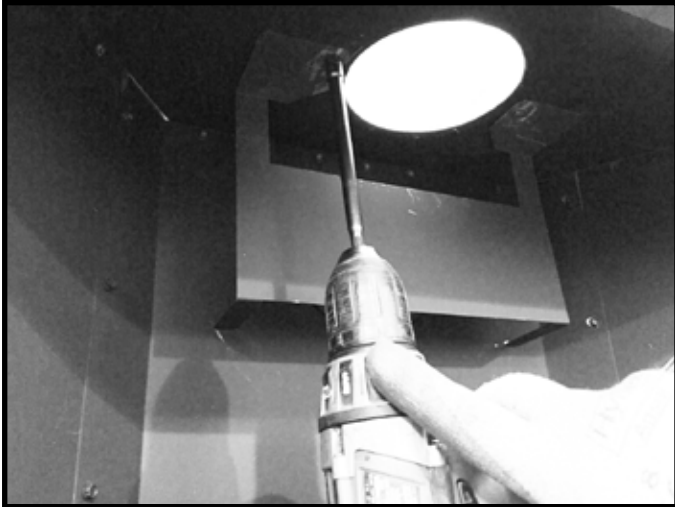

Figure 4.16 Remove Flue Visor

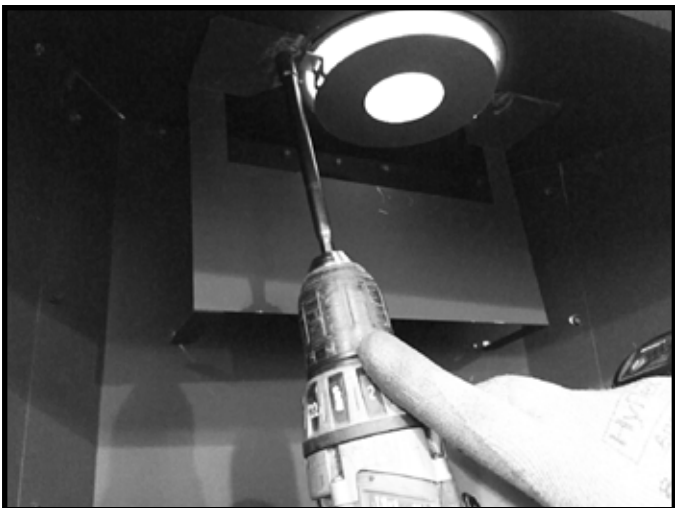

Figure 4.17 12 ft. to 30 ft. Vertical Run

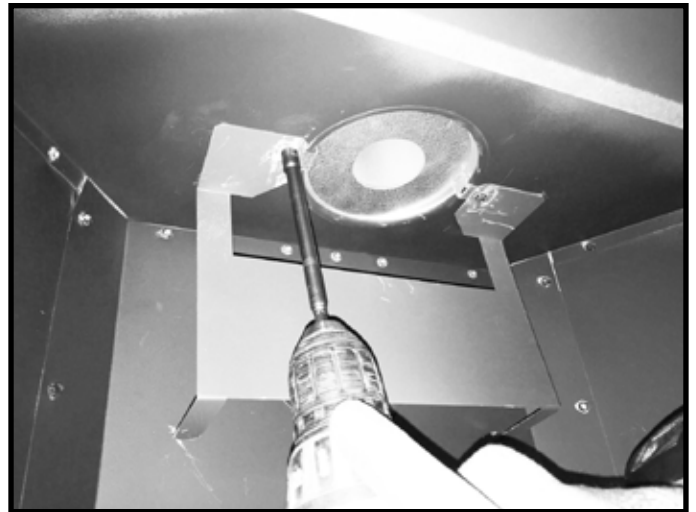
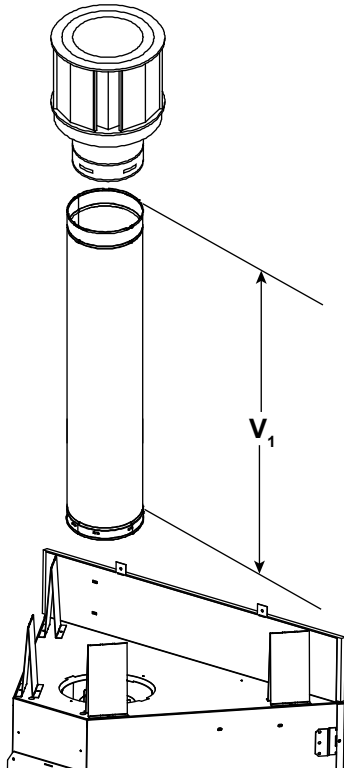

Figure 4.18 31 ft. to 60 ft. Vertical Run

Top Vent - Vertical Termination

No Elbow



$$V_1 = 60 \text{ ft. Max. (18.3 m)}$$
$$V_1 = 6 \text{ ft. Min. (1.8 m)}$$

Note: If installing a vertical vent/termination off the top of the appliance, the flue restrictor should be used.

Figure 4.19

Two Elbows

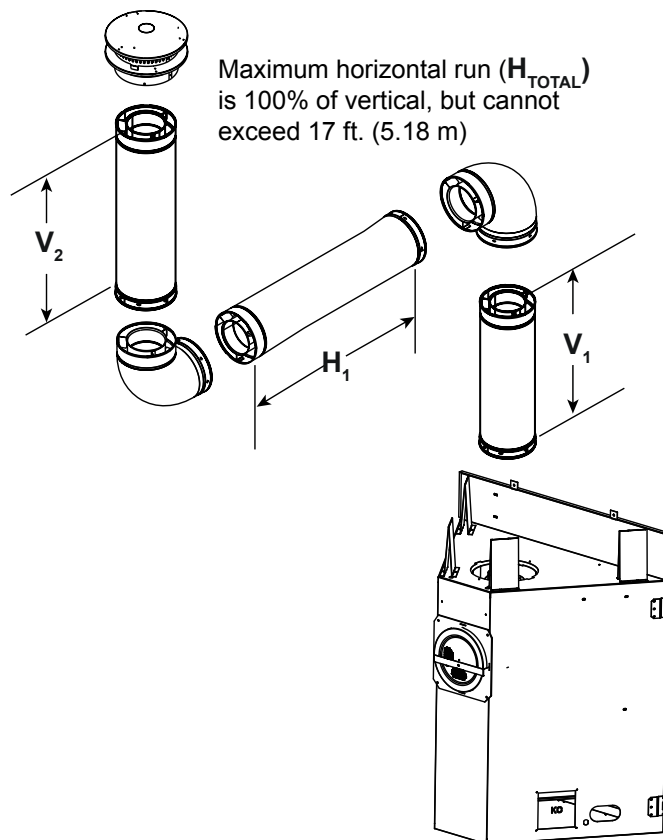

$$V_1 + V_2 = 60 \text{ ft. Max. (18.3 m)}$$
$$V_1 + V_2 = 12 \text{ ft. Min. (3.7 m)}$$

Figure 4.20

Three Elbows

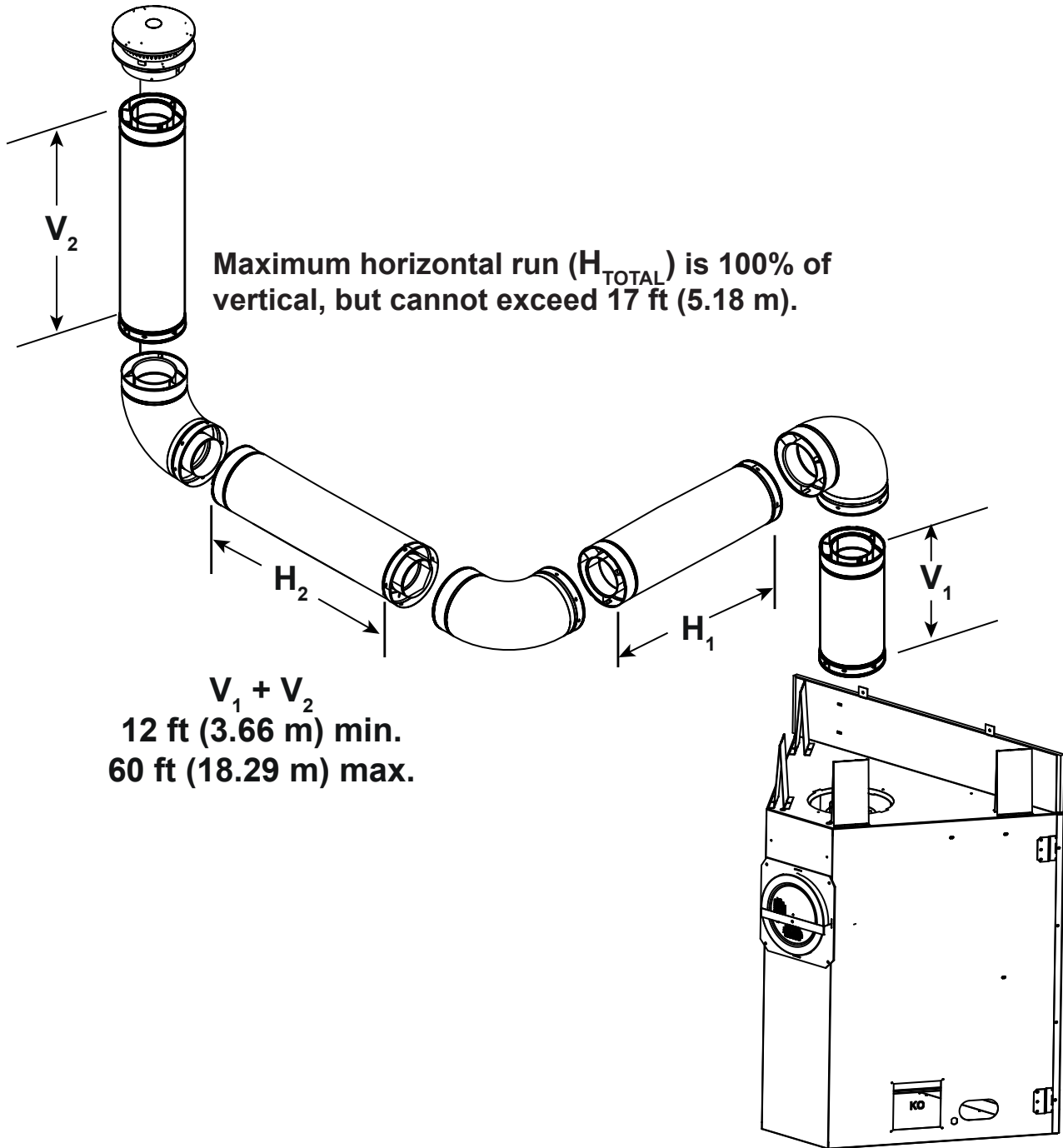

Figure 4.21

Rear Vent - Horizontal Termination

No Elbow

$H_1 = 18 \text{ in. (457 mm) Maximum}$

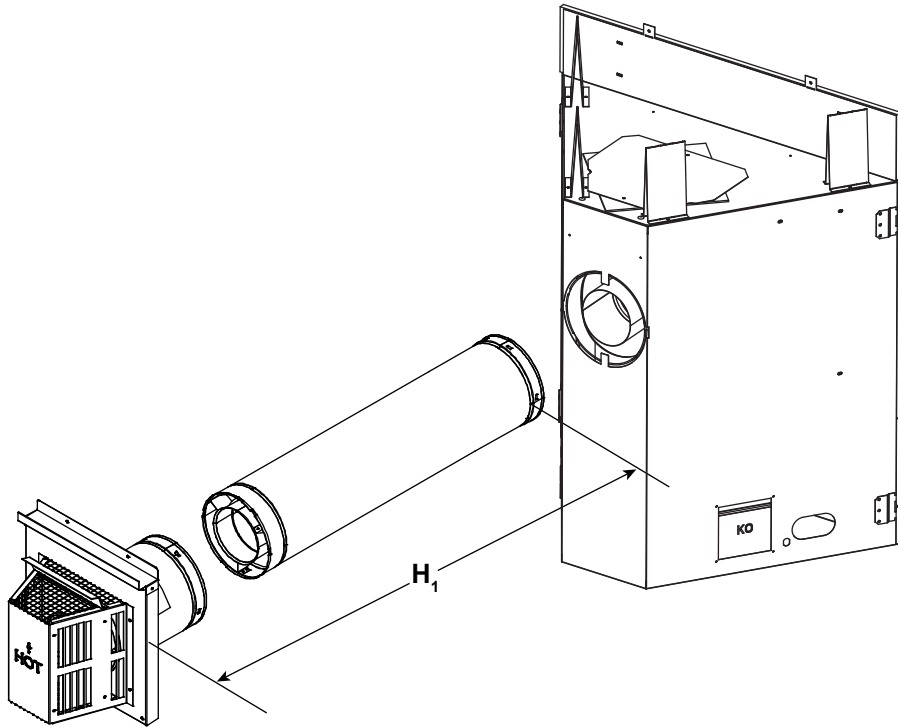
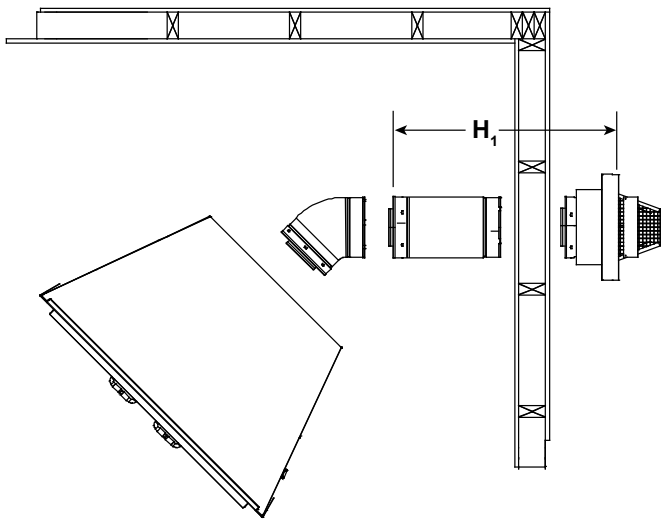

Figure 4.22

One 45° Elbow

$H_1 = 9 \text{ in. (229 mm) Maximum}$



NOTICE: To ensure proper operation of appliance, remove the pilot shield when the venting configuration includes a single 45° elbow and horizontal termination.

Remove pilot shield by removing the two screws and lifting the pilot shield out of the appliance as shown.

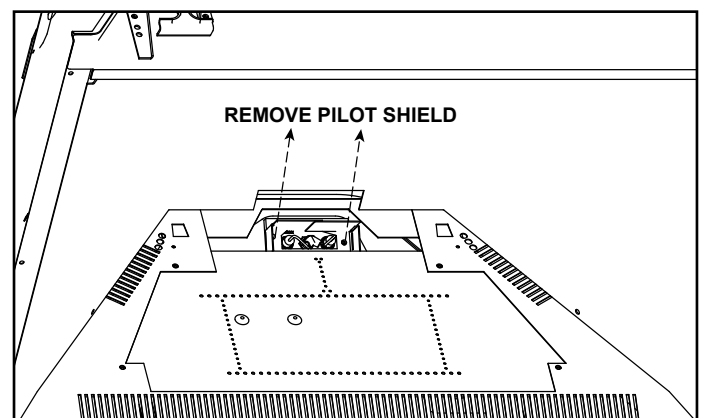

Figure 4.23

Rear Vent - Horizontal Termination - (continued)

Two Elbows

H ₁ Maximum		V ₁ Minimum		H ₁ + H ₂ Maximum	
0 ft	0 mm	1 ft	305 mm	3 ft	914 mm
2 ft	610 mm	1 ft	305 mm	3 ft	914 mm
4 ft	1.2 m	2 ft	610 mm	6 ft	1.8 m
6 ft	1.8 m	3 ft	914 mm	9 ft	2.7 m
8 ft	2.4 m	4 ft	1.2 m	12 ft	3.7 m
8 ft	2.4 m	5 ft	1.5 m	15 ft	4.6 m
8 ft	2.4 m	6 ft	1.8 m	18 ft	5.5 m
V ₁ + H ₁ + H ₂ = 50 ft (15.2 m) Maximum H ₁ = 8 ft (2.4 m) Maximum					

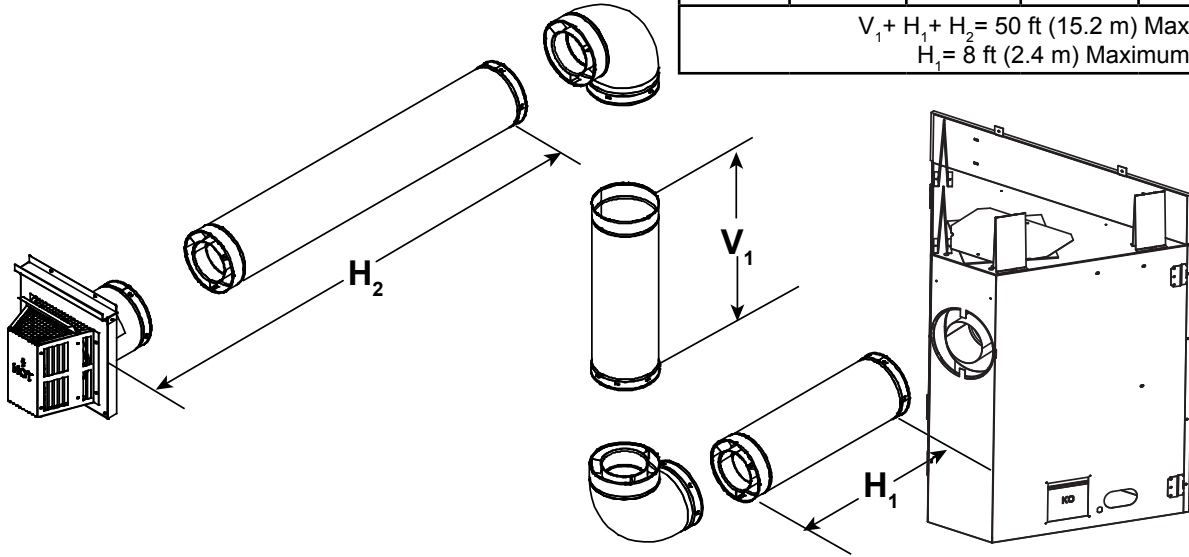

Figure 4.24

Three Elbows

H ₁ Maximum		V ₁ Minimum		H ₁ + H ₂ + H ₃ Maximum	
0 ft	0 mm	1 ft	305 mm	3 ft	914 mm
2 ft	610 mm	1 ft	305 mm	3 ft	914 mm
4 ft	1.2 m	2 ft	610 mm	3 ft	914 mm
6 ft	1.8 m	3 ft	914 mm	6 ft	1.8 m
8 ft	2.4 m	4 ft	1.2 m	9 ft	2.7 m
8 ft	2.4 m	5 ft	1.5 m	12 ft	3.7 m
8 ft	2.4 m	6 ft	1.8 m	15 ft	4.6 m
V ₁ + H ₁ + H ₂ + H ₃ = 47 ft (14.3 m) Maximum H ₁ = 8 ft (2.4 m) Maximum					

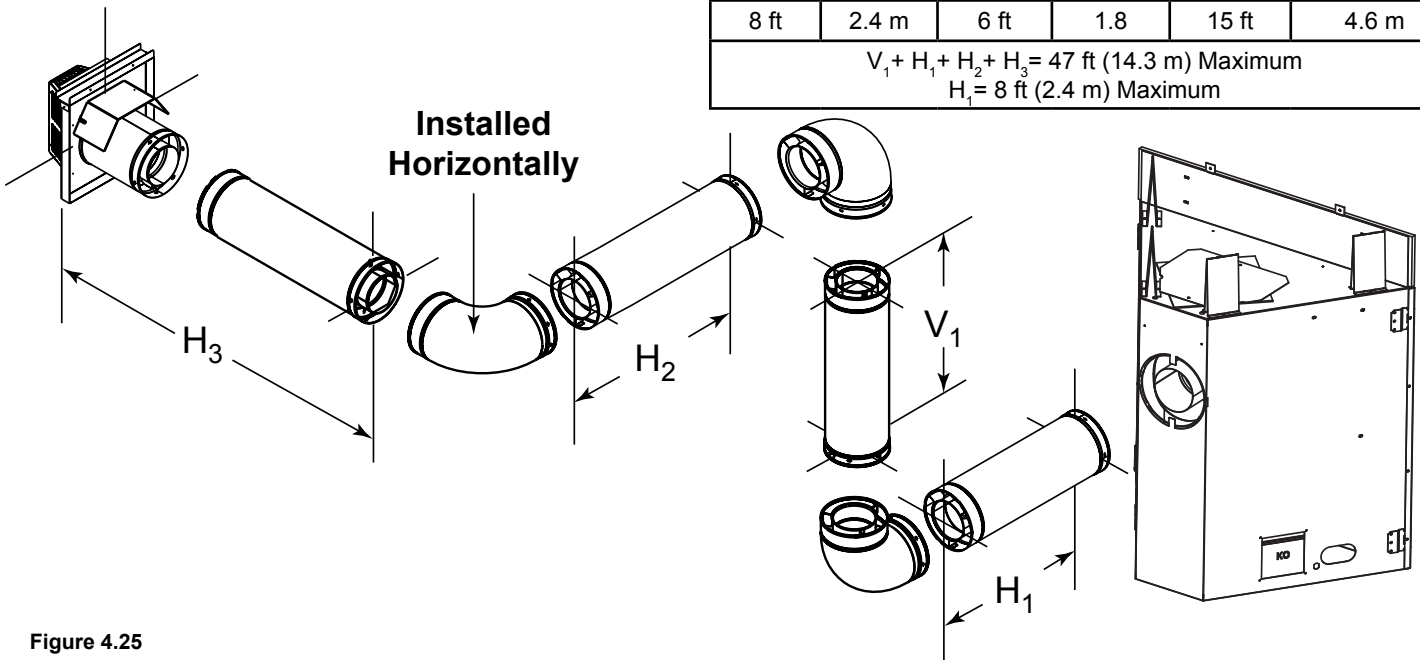

Figure 4.25

Rear Vent - Vertical Termination

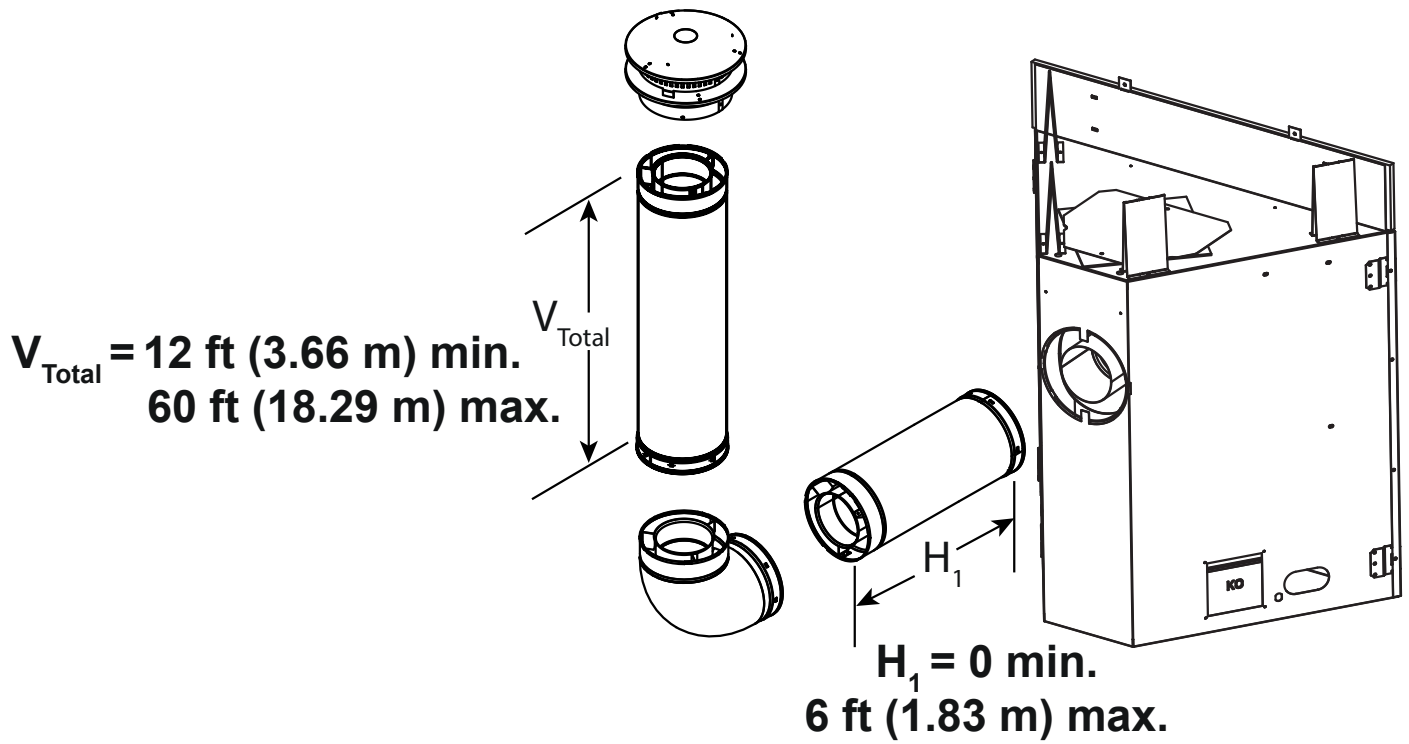

Figure 4.26

Two Elbows

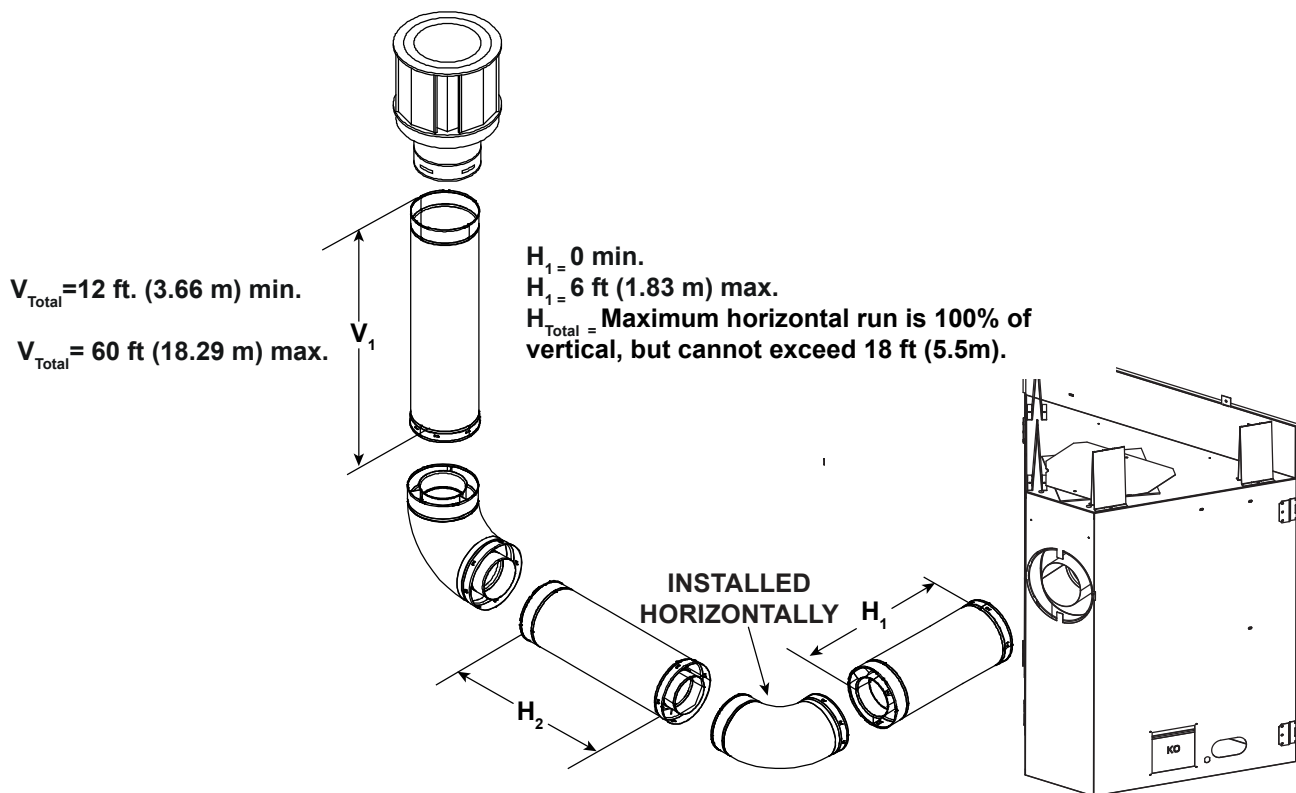

Figure 4.27

Three Elbows

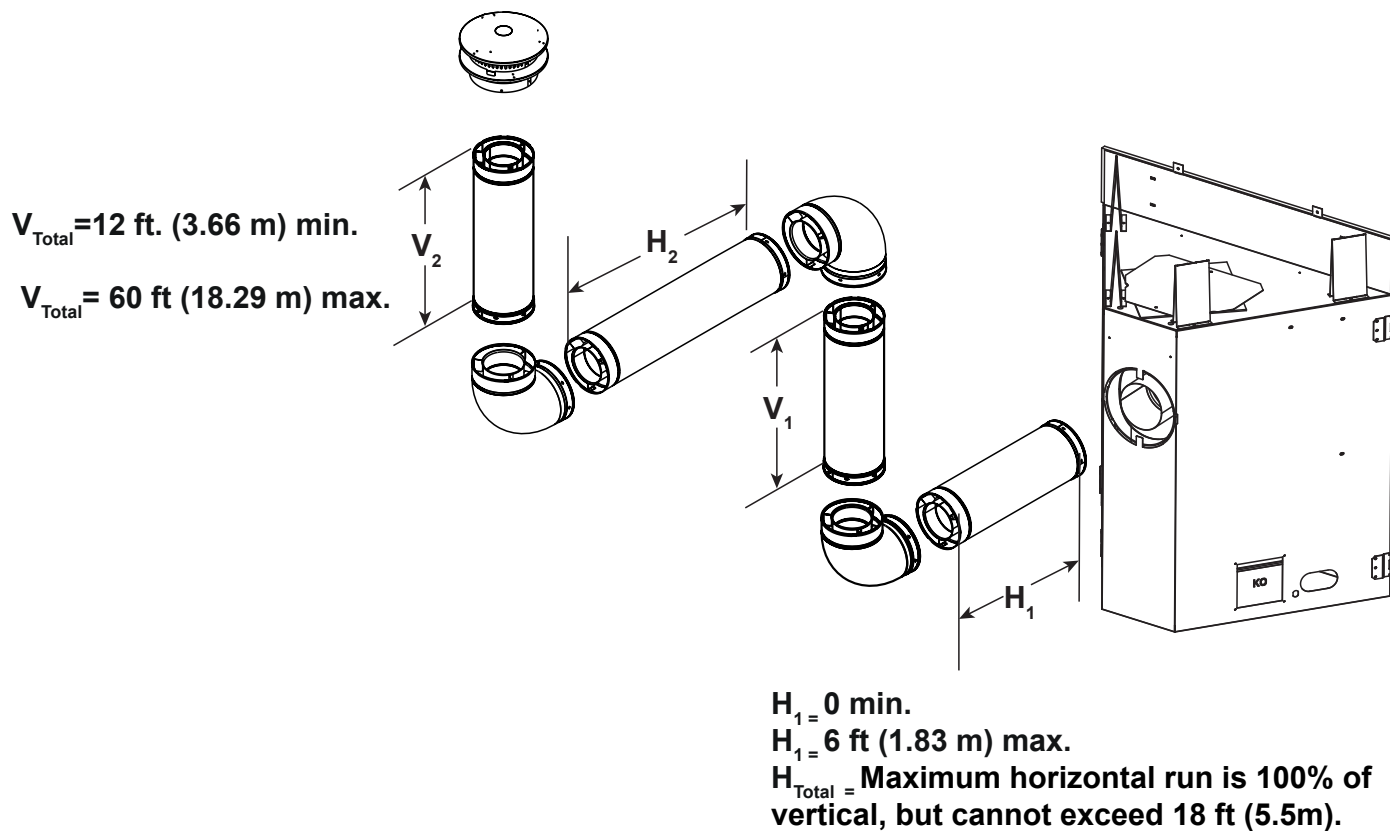

Figure 4.28

5 Vent Clearances and Framing

A. Pipe Clearances to Combustibles

WARNING! Risk of Fire! Maintain air space clearance to vent. DO NOT pack insulation or other combustibles:

- Between ceiling firestops
- Between wall shield firestops
- Around vent system

Failure to keep insulation or other material away from vent pipe could cause overheating and fire.

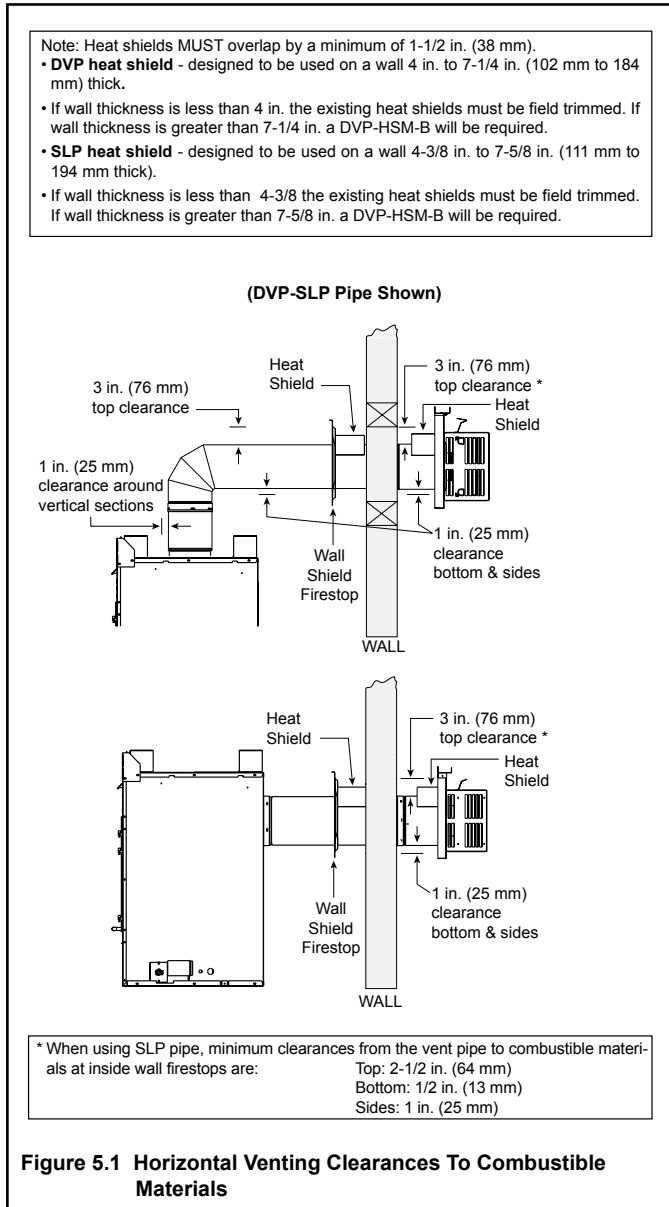

B. Wall Penetration Framing/Firestops

Combustible Wall Penetration

Whenever a combustible wall is penetrated, you must frame a hole for the wall shield firestop(s). The wall shield firestop maintains minimum clearances and prevents cold air infiltration.

- The opening must be framed on all four sides using the same size framing materials as those used in the wall construction.
- SLP pipe - A wall shield firestop must be placed on each side of an interior wall. A minimum 1-1/2 in. (38 mm) overlap of attached heat shields must be maintained.
- DVP pipe - A wall shield firestop is required on one side only on interior walls. If your local inspector requires a wall shield firestop on both sides, then both wall shield firestops must have a heat shield (refer to Section 12.A.) attached to them.
- See Section 7.F. for information for regarding the installation of a horizontal termination cap.

Non-Combustible Wall Penetration

If the hole being penetrated is surrounded by non-combustible materials such as concrete, a hole with diameter one inch greater than the pipe is acceptable.

Whenever a non-combustible wall is penetrated, the wall shield firestop is only required on one side and no heat shield is necessary.

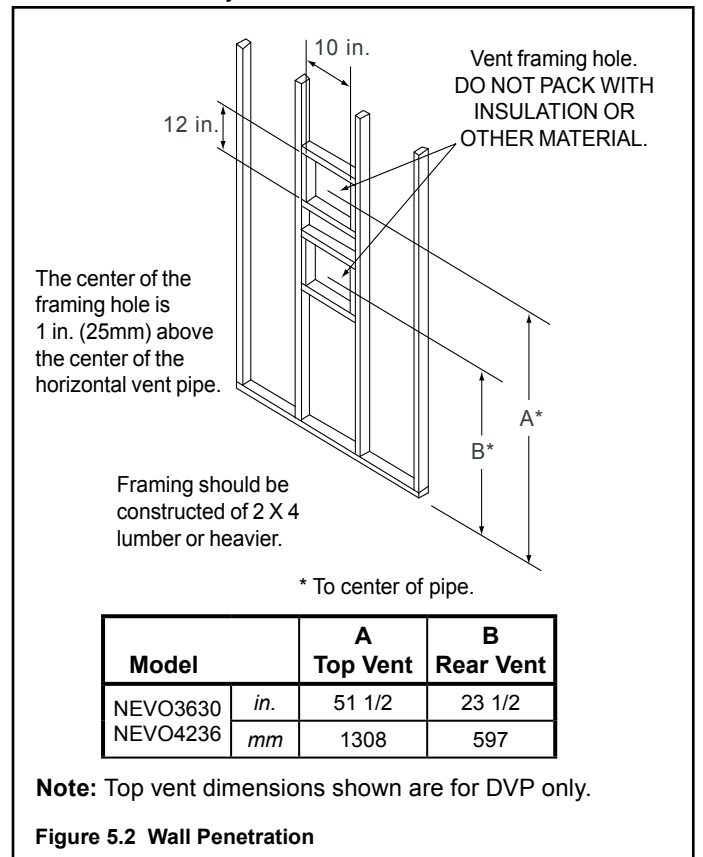

C. Ceiling Firestop/Floor Penetration Framing

A ceiling firestop **MUST** be used between floors and attics.

- **DVP pipe only** - Frame an opening 10 in. by 10 in. (254 mm by 254 mm) whenever the vent penetrates a ceiling/floor (see Figure 5.3).
- **SLP pipe only** - Frame opening 9 in. x 9 in. (229 mm x 229 mm) whenever the vent penetrates a ceiling/floor (see Figure 5.3).
- Frame the area with the same sized lumber as used in ceiling/floor joist.
- The ceiling firestop may be installed above or below the ceiling joists when installed with an attic insulation shield. It must be under joists between floors that are not insulated. Refer to Figure 5.4.
- Secure in place with nails or screws.

WARNING! Risk of Fire! DO NOT pack insulation around the vent. Insulation must be kept back from the pipe to prevent overheating.

D. Install Attic Insulation Shield

WARNING! Fire Risk. DO NOT allow loose materials or insulation to touch vent. Hearth & Home Technologies requires the use of an attic shield.

The International Fuel Gas Code requires an attic shield constructed of 26 gauge minimum steel that extends at least 2 in. (51 mm) above insulation.

- Attic insulation shields must meet specified clearances to combustible materials and be secured in place.
- An attic insulation shield kit is available from Hearth & Home Technologies. Contact your dealer to order. Install attic insulation shield according to instructions included with kit.

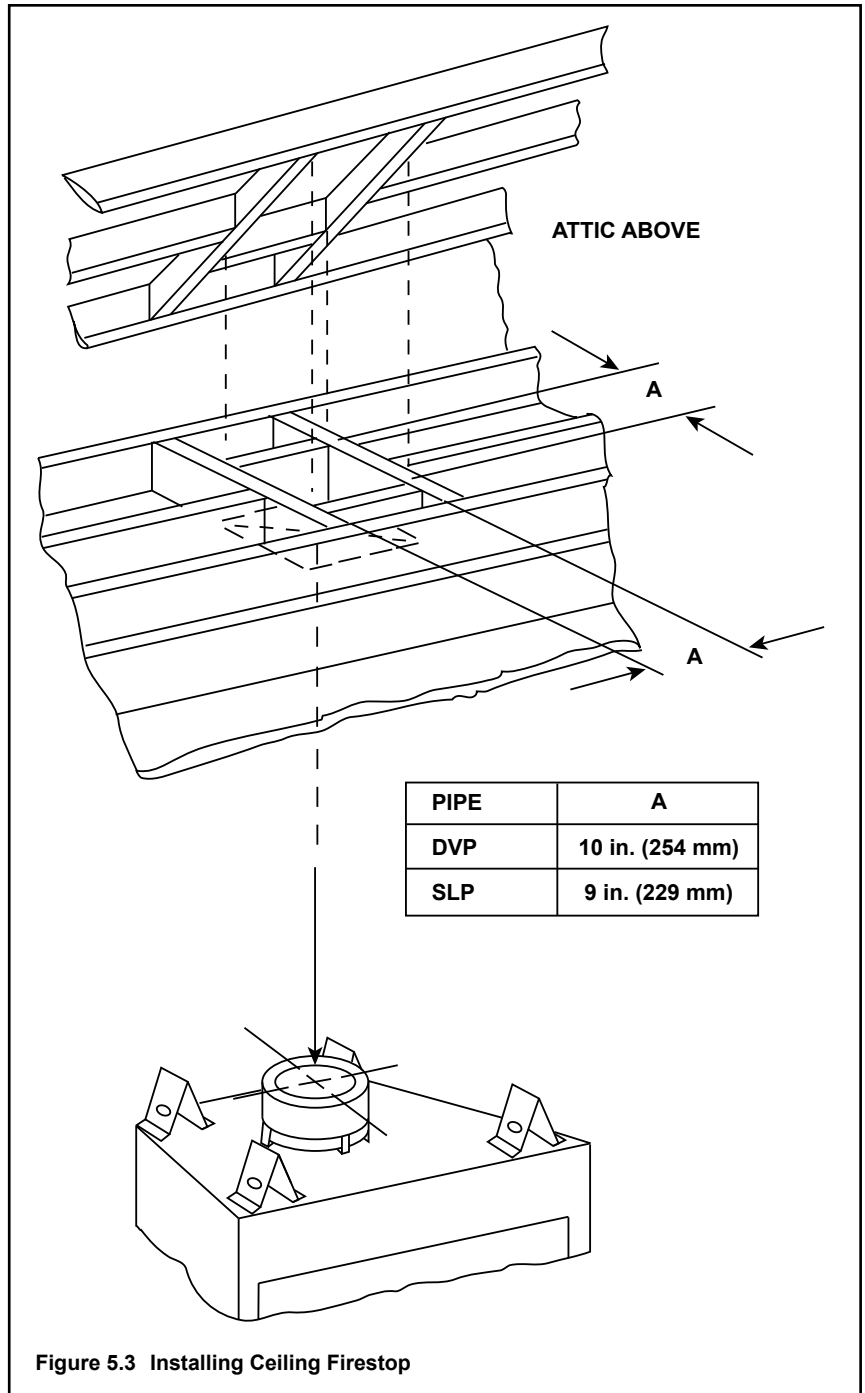

Figure 5.3 Installing Ceiling Firestop

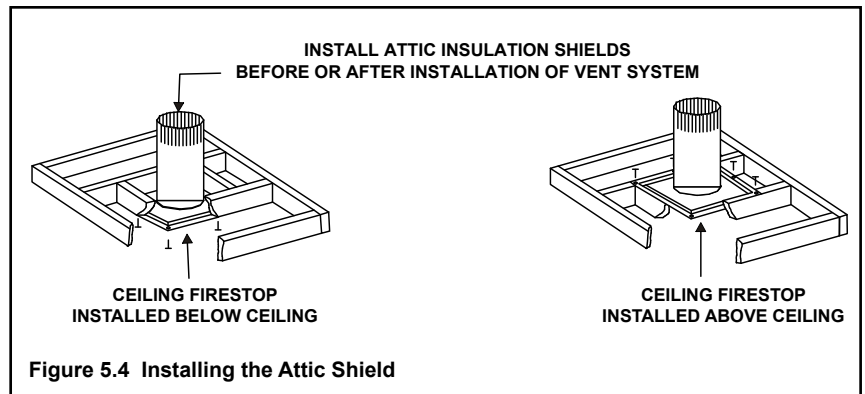

Figure 5.4 Installing the Attic Shield

6 Appliance Preparation

A. Vent Collar Preparation

CAUTION! Risk of Cuts, Abrasions or Flying Debris. Wear protective gloves and safety glasses during installation. Sheet metal edges are sharp.

NOTICE: Once appliance is set up for top or rear venting, it CANNOT be changed at a later time.

Top Vent

- Remove the cover plate by removing the four screws holding it to the top of the appliance. Remove and discard the cover plate.



Figure 6.1

- Remove the center insulation plug.



Figure 6.2

- Cut the metal retaining band and fold the sides out.

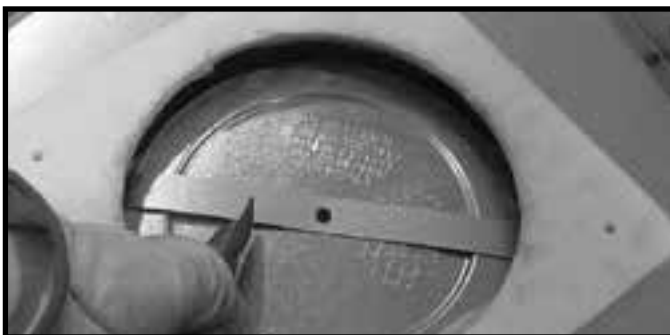

Figure 6.3

- Fold the center parts of the retaining band up and use to remove the vent cap.



Figure 6.4

- Discard the vent cap, remove and discard the insulation basket.

Note: Once the vent cap has been removed it cannot be reattached.



Figure 6.5

- Remove the insulation from the outer vent pipe. For rear venting there is no insulation in the outer vent pipe.

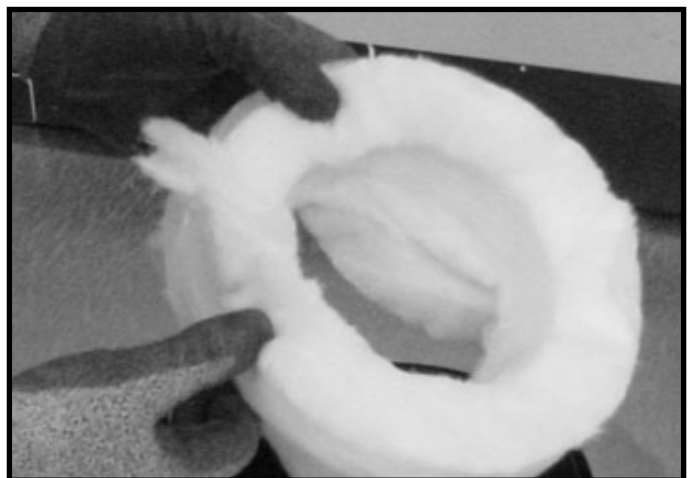

Figure 6.6

- Snap the first vent section into place.

Rear Vent

NOTICE: Once appliance is set up for top or rear venting, it **CANNOT** be changed at a later time.

- Fold the tabs toward the center of the vent cap (90°) and remove the insulation gasket.



Figure 6.7

- Cut the metal retaining band and fold the sides out.

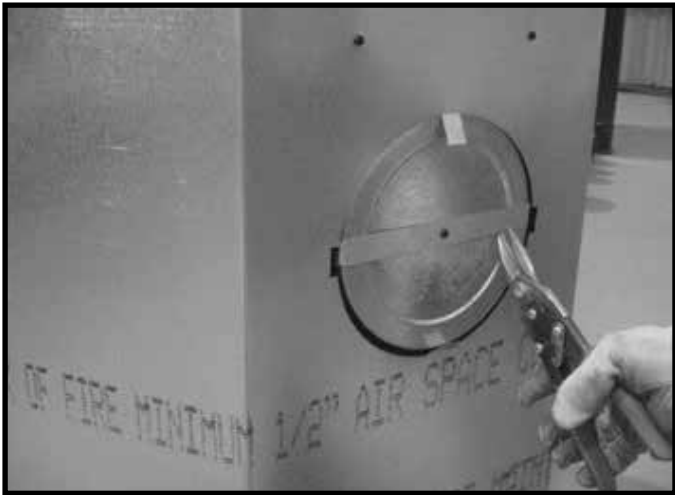

Figure 6.8

- Fold the center parts of the retaining band out and use to remove the vent cap.



Figure 6.9

- Discard the vent cap, remove and discard the insulation basket.

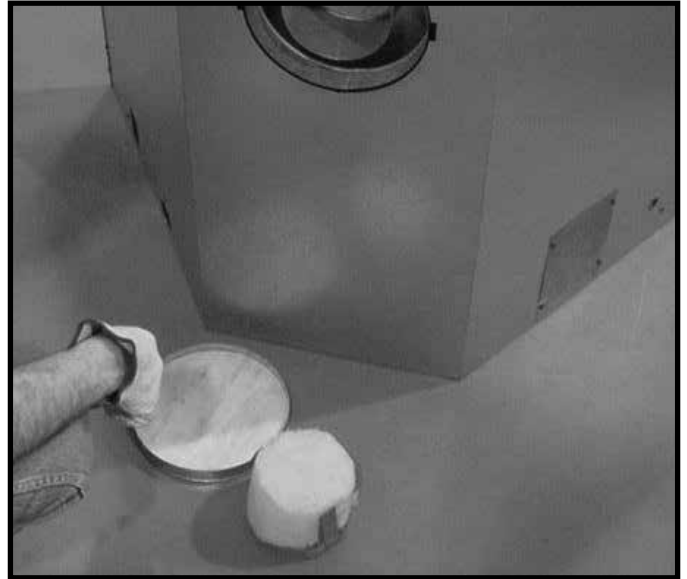

Figure 6.10

- Attach the first vent section (it will snap into place). Slide the insulation gasket onto the vent section, up against the appliance and over the tabs.

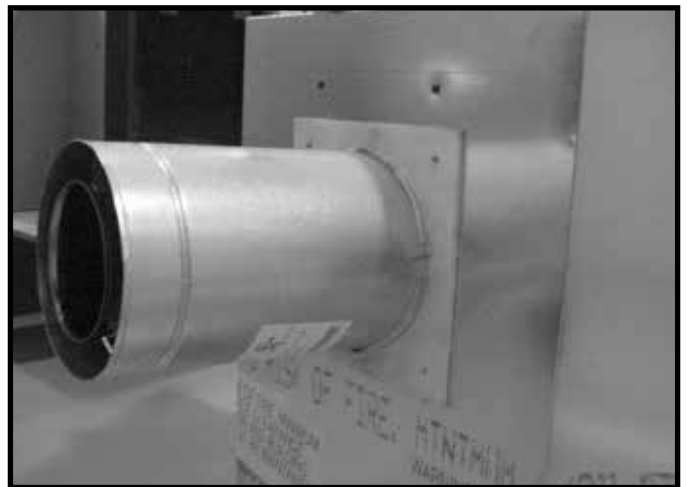

Figure 6.11

B. Securing and Leveling the Appliance

WARNING! Risk of Fire! Prevent contact with:

- Sagging or loose insulation
- Insulation backing or plastic
- Framing and other combustible materials

Block openings into the chase to prevent entry of blown-in insulation. Make sure insulation and other materials are secured.

DO NOT notch the framing around the appliance standoffs.

Failure to maintain air space clearance could cause overheating and fire.

The diagram shows how to properly position and secure the appliance. See Figure 6.12. Nailing tabs are provided to secure the appliance to the framing members.

- Bend out nailing tabs on each side.
- Place the appliance into position.
- Keep nailing tabs flush with the framing.
- Level the appliance from side to side and front to back.
- Shim the appliance as necessary. It is acceptable to use wood shims underneath the appliance.
- Secure the appliance to the framing by using nails or screws through the nailing tabs.
- Optional: Secure the appliance to the floor by inserting two screws through the pilot holes at the bottom of the appliance.

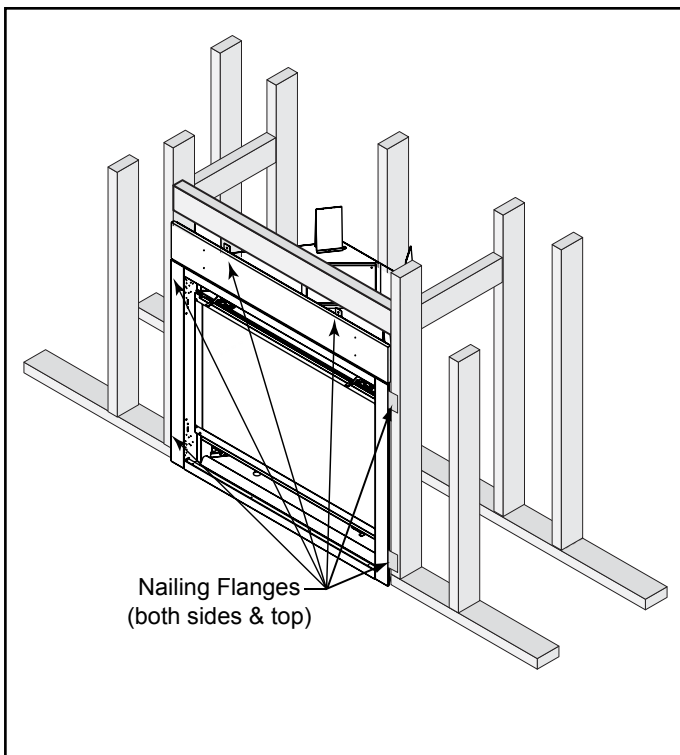

Figure 6.12 Proper Positioning and Securing of an Appliance

7 Venting and Chimneys

A. Assemble Vent Sections

(DVP Pipe Only)

Attach Vent to the Firebox Assembly

Note: The end of the pipe sections with the lanced tabs will face toward the appliance.

Attach the first pipe section to the starting collar:

- Lanced pipe end of the starting collar.
- Inner pipe over inner collar.
- Push the pipe section until all lanced tabs snap in place.
- Lightly tug on pipe to confirm it has locked.

Required Commercial, Multi-family (Multi-level exceeding two stories), or High-Rise Applications

All outer pipe joints must be sealed with 100% silicone (300 °F minimum continuous exposure rating), including the slip section that connects directly to the horizontal termination cap.

- Apply a bead of silicone sealant (300 °F minimum continuous exposure rating) inside the female outer pipe joint prior to joining sections. See Figure 7.1. **OR**

Apply a bead of silicone sealant (300 °F minimum continuous exposure rating) to the outside of connecting joint after joining sections **OR**

Apply aluminum foil tape (300 °F minimum continuous exposure rating) to the outside of connecting joint after joining sections. On horizontal pipe runs, it is recommended that the tape seam is positioned on the bottom side of the vent pipe.

- Only outer pipes need to be sealed. All unit collar, pipe, slip section, elbow and cap outer flues shall be sealed in this manner, unless otherwise stated.

WARNING! Risk of Fire or Explosion! DO NOT break silicone seals on slip sections. Use care when removing termination cap from slip pipe. If slip section seals are broken during removal of the termination cap, vent could leak.

Assemble Pipe Sections

Per Figure 7.2:

- Start the inner pipe on the lanced end of section A into the flared end of section B.
 - Start the outer pipe of section A over the outer pipe of section B.
 - Once both vents sections are started, push firmly until all lanced tabs lock into place.
 - Lightly tug on the pipe to confirm the tabs have locked.
- It is acceptable to use screws no longer than 1/2 in. (13 mm) to hold outer pipe sections together. If predrilling holes, **DO NOT** penetrate inner pipe.

For 90° and 45° elbows that are changing the vent direction from horizontal to vertical, one screw minimum should be put in the outer flue at the horizontal elbow joint to prevent the elbow from rotating. Use screws no longer than 1/2 in. (13 mm). If predrilling screw holes, **DO NOT** penetrate inner pipe.



Figure 7.1 High Temperature Silicone Sealant

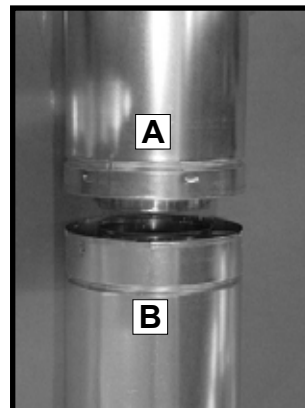

Figure 7.2

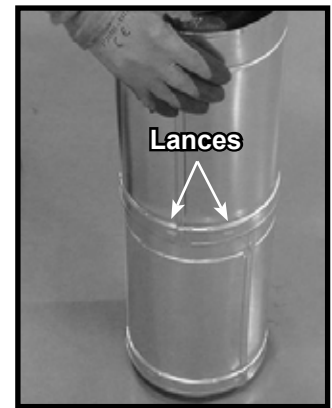

Figure 7.3

Note: Make sure that the seams are not aligned to prevent unintentional disconnection.

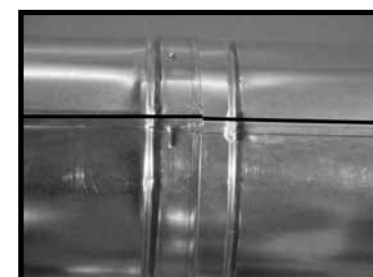
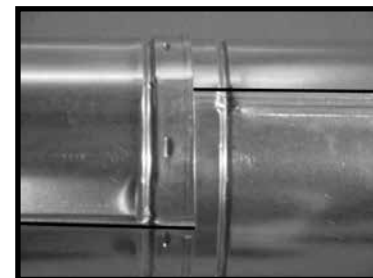

Figure 7.4 Seams

Assemble Vent Sections

(SLP Only)

To attach the first vent component to the starting collars of the appliance:

- Attach a DVP-SLP24 adapter to the starting collar of the appliance.
- Lock the vent components into place by sliding the pipe section onto the collar.
- Align the seam of the pipe and seam of collar to allow engagement. Rotate the vent component to lock into place. Use this procedure for all vent components. See Figure 7.5.
- Slide the gasket over the first vent section and place it flush to the appliance. This will prevent cold air infiltration. Caulk with a minimum of 300 °F continuous exposure rating may be used to hold the part in place.
- Continue adding vent components, locking each succeeding component into place.
- Ensure that each succeeding vent component is securely fitted and locked into the preceding component.

Required Commercial, Multi-family (Multi-level exceeding two stories), or High-Rise Applications

For Installation into a commercial, multi-family (multi-level exceeding two stories) or high-rise applications: All outer pipe joints must be sealed with high temperature silicone (300 °F minimum continuous exposure rating), including the slip section that connects directly to the horizontal termination cap.

- Apply a bead of silicone sealant (300 °F minimum continuous exposure rating) inside the female outer pipe joint prior to joining sections. See Figure 7.1.
- Only outer pipes need to be sealed. All unit collar, pipe, slip section, elbow and cap outer flues shall be sealed in this manner, unless otherwise stated.

WARNING! Risk of Fire or Explosion! DO NOT break silicone seals on slip sections. Use care when removing termination cap from slip pipe. If slip section seals are broken during removal of the termination cap, vent could leak.

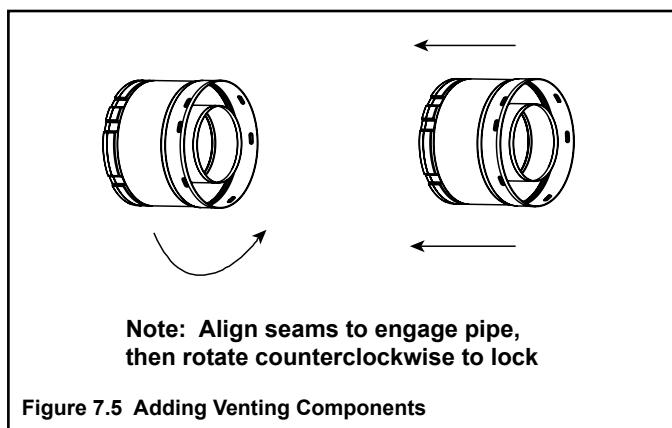

B. Assemble Slip Sections

- Slide the inner flue of the slip section into the inner flue of the pipe section and the outer flue of the slip section over the outer flue of the pipe section. See Figure 7.6.
- Slide together to the desired length.

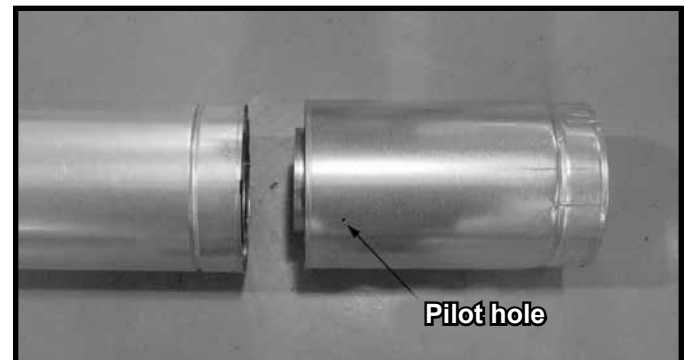

Figure 7.6 Slip Section Pilot Holes

- Maintain a 1-1/2 in. (38 mm) overlap between the slip section and the pipe section.
- Secure the pipe and slip section with two screws no longer than 1/2 in. (13 mm), using the pilot holes in the slip section. See Figure 7.7.

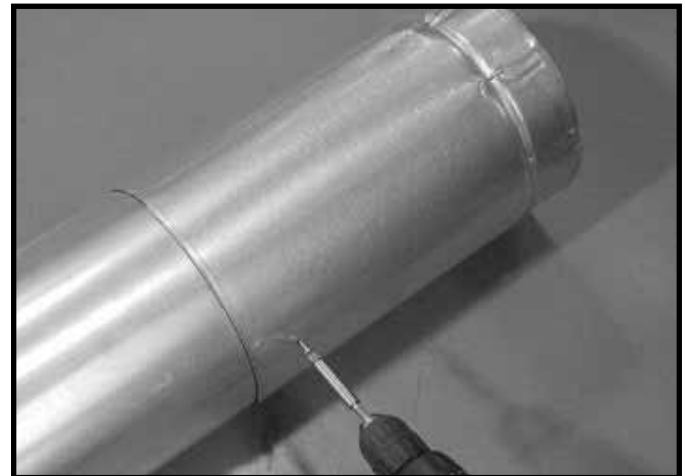

Figure 7.7 Screws into Slip Section

- Continue adding pipe as necessary following instructions in "Assembling Pipe Sections."

NOTICE: If slip section is too long, the inner and outer flues of the slip section can be cut to the desired length.

NOTICE: When installing a vent system with an HRC termination cap, all pipe system joints shall be sealed using a high temperature silicone sealant (300 °F minimum continuous exposure rating).

- Apply a bead of silicone sealant (300 °F minimum continuous exposure rating) inside the female outer pipe joint prior to joining sections.
- Only outer pipes are sealed, sealing the inner flue is not required.
- All unit collar, pipe, slip section, elbow and cap outer flues shall be sealed.

C. Secure the Vent Sections

- Vertical runs originating off the top of the appliance, with no offsets, must be supported every 8 ft. (2.44 m) after the maximum allowed 25 ft. (7.62 m) of unsupported rise.
- Vertical runs originating off the rear of the appliance, or after any elbow, must be supported every 8 ft. (2.44 m).
- Horizontal runs must be supported every 5 feet (1.52 m).
- Vent supports or plumbers strap (spaced 120° apart) may be used to support vent sections. See Figures 7.8 and 7.9.
- Wall shield firestops may be used to provide horizontal support to vent sections.
- SLP ceiling firestops have tabs that may be used to provide vertical support.

WARNING! Risk of Fire, Explosion or Asphyxiation! Improper support could allow vent to sag and separate. Use vent run supports and connect vent sections per installation instructions. **DO NOT** allow vent to sag below connection point to appliance.

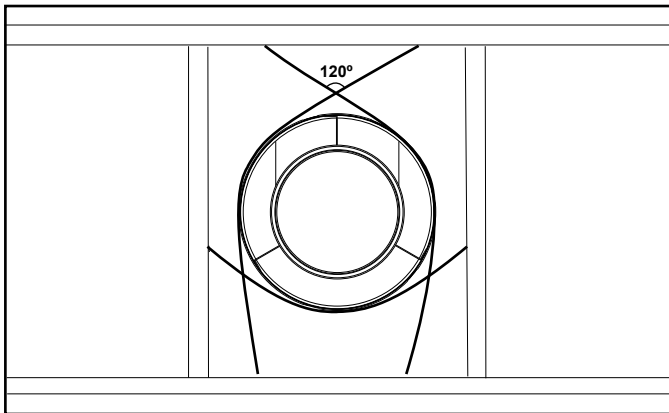

Figure 7.8 Securing Vertical Pipe Sections

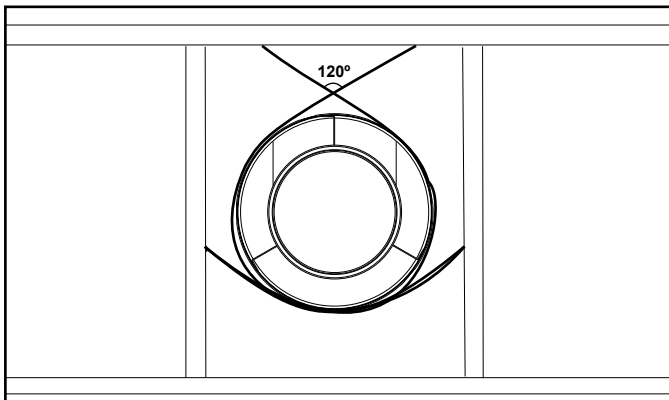

Figure 7.9 Securing Horizontal Pipe Sections

D. Disassemble Vent Sections

- Rotate either section (see Figure 7.10) so the seams on both pipe sections are aligned as shown in Figure 7.11.
- Pull carefully to separate the pieces of pipe.

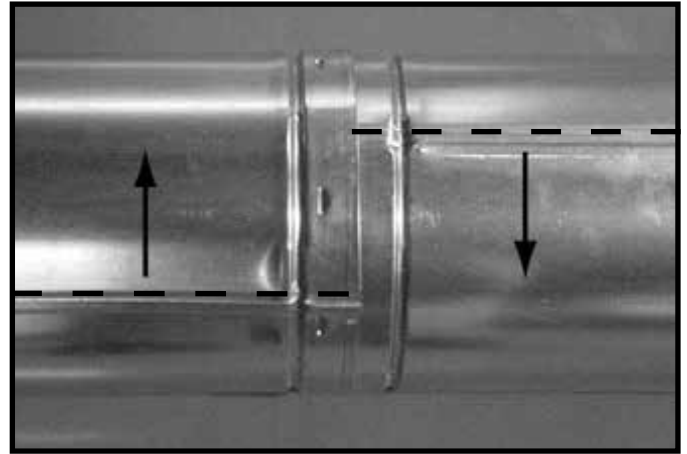

Figure 7.10 Rotate Seams for Disassembly

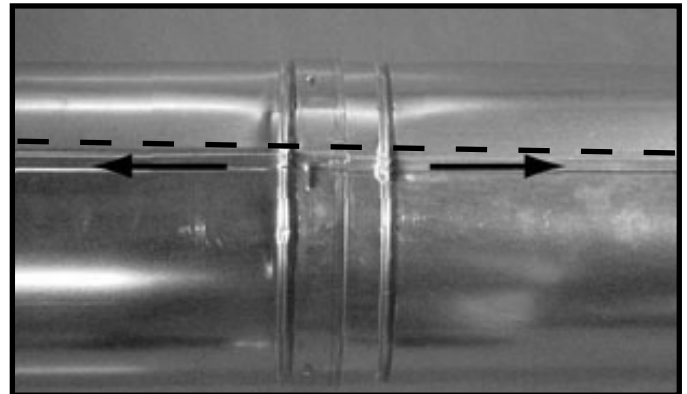
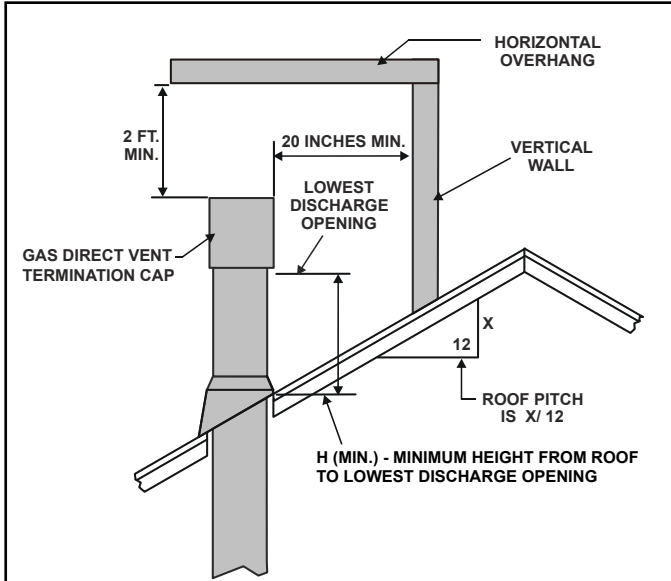

Figure 7.11 Align and Disassemble Vent Sections

E. Vertical Termination Requirements

Install Metal Roof Flashing

- See minimum vent heights for various pitched roofs (Figure 7.12) to determine the length of pipe to extend through the roof.
- Slide the roof flashing over the pipe sections extending through the roof as shown in Figure 7.13.



<u>Roof Pitch</u>	<u>H (Min.) Ft.</u>
Flat to 6/12.....	1.0*
Over 6/12 to 7/12.....	1.25*
Over 7/12 to 8/12.....	1.5*
Over 8/12 to 9/12.....	2.0*
Over 9/12 to 10/12.....	2.5*
Over 10/12 to 11/12.....	3.25
Over 11/12 to 12/12.....	4.0
Over 12/12 to 14/12.....	5.0
Over 14/12 to 16/12.....	6.0
Over 16/12 to 18/12.....	7.0
Over 18/12 to 20/12.....	7.5
Over 20/12 to 21/12.....	8.0

* H minimum may vary depending on regional snowfall. Refer to local codes.

Figure 7.12 Minimum Height From Roof to Lowest Discharge Opening

NOTICE: Failure to properly caulk the roof flashing and pipe seams could permit entry of water.

- Caulk the gap between the roof flashing and the outside diameter of the pipe.
- Caulk the perimeter of the flashing where it contacts the roof surface. See Figure 7.13
- Caulk the overlap seam of any exposed pipe sections that are located above the roof line.

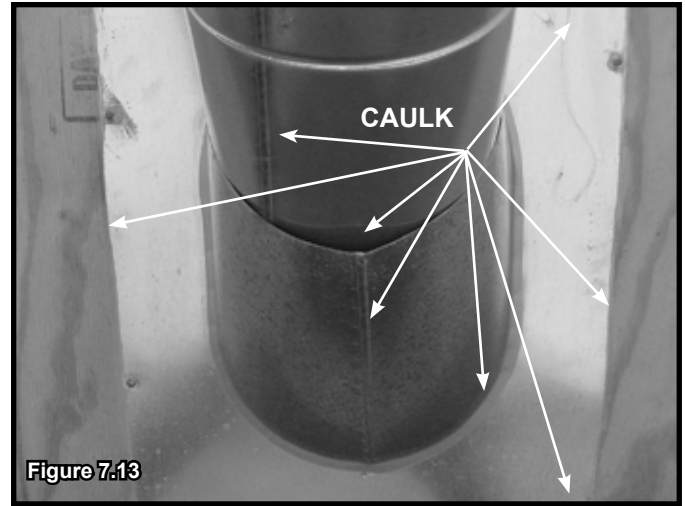

Figure 7.13

Assemble and Install Storm Collar

CAUTION! Risk of Cuts, Abrasions or Flying Debris. Wear protective gloves and safety glasses during installation. Sheet metal edges are sharp.

- Slide the storm collar onto the exposed pipe section and align brackets.
- Insert a bolt (provided) through the brackets and install nut. Do not completely tighten.



- Slide the assembled storm collar down the pipe section until it rests on the roof flashing (see Figure 7.14).
- Tighten nut and make sure the collar is tight against the pipe section.
- Caulk around the top of the storm collar. See Figure 7.15.

Install Vertical Termination Cap

- Attach the vertical termination cap by sliding the inner collar of the cap into the inner flue of the pipe section while placing the outer collar of the cap over the outer flue of the pipe section.
- Secure the cap by driving three self-tapping screws (supplied) through the pilot holes in the outer collar of the cap into the outer flue of the pipe (see Figure 7.15).

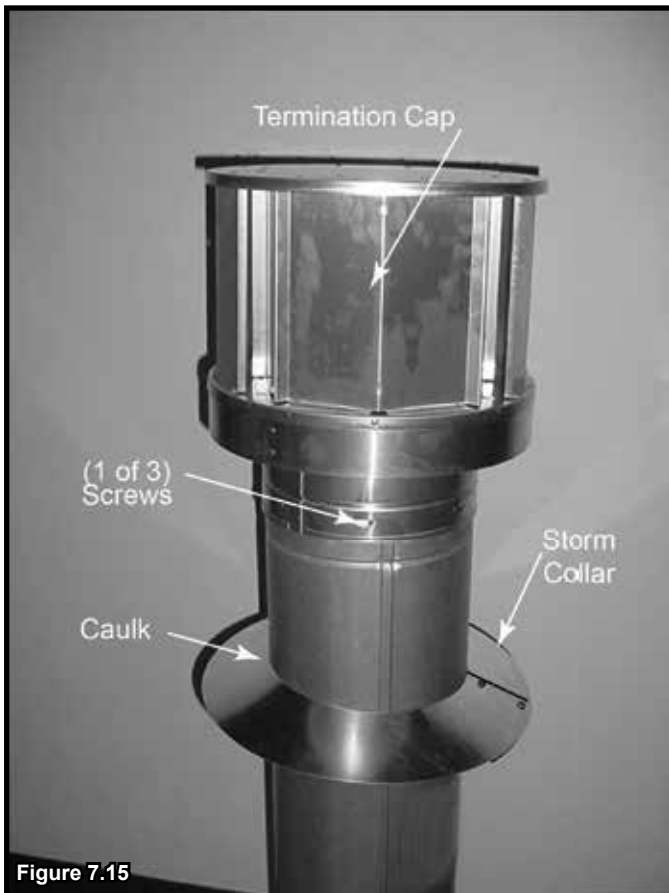

Figure 7.15

F. Horizontal Termination Requirements

Heat Shield Requirements for Horizontal Termination

WARNING! Risk of Fire! To prevent overheating and fire, heat shields must extend through the entire wall thickness.

- **DO NOT** remove the heat shields attached to the wall shield firestop and the horizontal termination cap (shown in Figure 7.16).
- Heat shields must overlap 1-1/2 in. (38 mm) minimum.

There are two sections of the heat shield. One section is factory-attached to the wall shield firestop. The other section is factory-attached to the cap. See Figure 7.16.

If the wall thickness does not allow the required 1-1/2 in. (38 mm) heat shield overlap when installed, an extended heat shield must be used.

- If the wall thickness is less than 4 in./102 mm (DVP) or 4-3/8 in./ 111 mm (SLP), the heat shields on the cap and wall shield firestop must be trimmed. A minimum 1-1/2 in. (38 mm) overlap **MUST** be maintained.
- Use an extended heat shield if the finished wall thickness is greater than 7-1/4 in. (184 mm).
- The extended heat shield may need to be cut to length maintaining sufficient length for a 1-1/2 in. (38 mm) overlap between heat shields.
- Attach the extended heat shield to either of the existing heat shields using the screws supplied with the extended heat shield. Refer to vent components diagrams in the back of this manual.
- Rest the small leg on the extended heat shield on top of the pipe section to properly space it from the pipe section.

Important Notice: Heat shields may not be field constructed.

Install Horizontal Termination Cap (DVP and SLP Pipe)

WARNING! Risk of Fire! The telescoping flue section of the termination cap **MUST** be used when connecting vent.

- 1-1/2 (38 mm) minimum overlap of flue telescoping section is required.

Failure to maintain overlap could cause overheating and fire.

- Vent termination must not be recessed in the wall. Siding may be brought to the edge of the cap base.
- Flash and seal as appropriate for siding material at outside edges of cap.
- When installing a horizontal termination cap, follow the cap location guidelines as prescribed by current **ANSI Z223.1** and **CAN/CGA-B149** installation codes and refer to Section 4 of this manual.

CAUTION! Risk of Burns! Local codes may require installation of a cap shield to prevent anything or anyone from touching the hot cap.

NOTICE: For certain exposures which require superior resistance to wind-driven rain penetration, a flashing kit and HRC caps are available. When penetrating a brick wall, a brick extension kit is available for framing the brick.

Note: When using termination caps with factory-supplied heat shield attached, no additional wall shield firestop is required on the exterior side of a combustible wall.

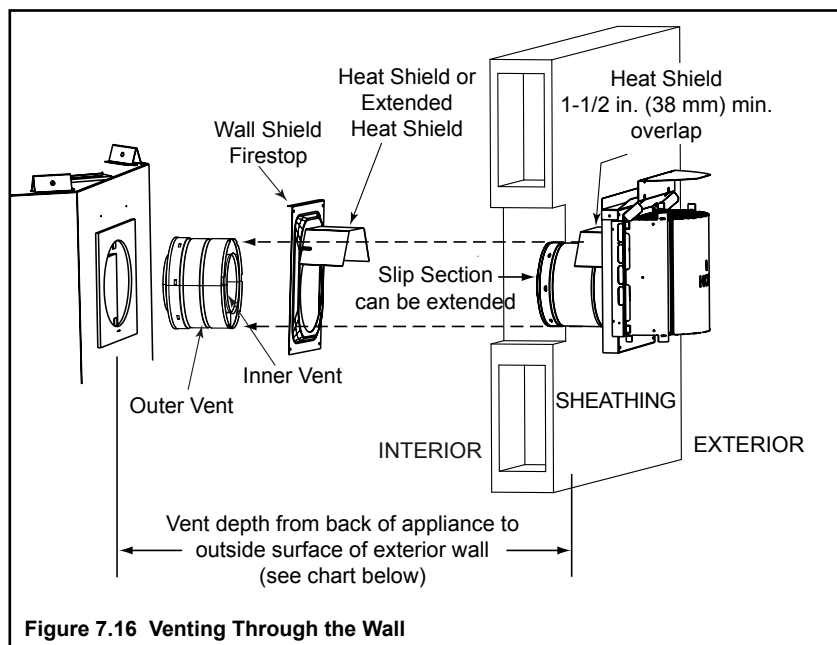

Figure 7.16 Venting Through the Wall

Cap Specification Chart (depth without using additional pipe sections)

NEVO Series	DVP-TRAPK1 Top Vent Depth	DVP-TRAP1 Rear Vent Depth	DVP-TRAPK2 Top Vent Depth	DVP-TRAP2 Rear Vent Depth	SLP-TRAP1 Top Vent Depth	SLP-TRAP2 Top Vent Depth
		4 1/2 to 6 3/8 in.	3 to 4 7/8 in.	6 7/8 to 10 7/8 in.	5 3/8 to 9 3/8 in.	2 to 3 7/8 in.
NEVO Series	DVP-HPC1 Top Vent Depth	DVP-HPC1 Rear Vent Depth	DVP-HPC2 Top Vent Depth	DVP-HPC2 Rear Vent Depth		
	4 1/2 to 6 5/8 in.	3 to 5 1/8 in.	6 5/8 to 10 3/4 in.	5 1/8 to 9 1/4 in.		

DVP-TRAP1 can adjust 1 1/2 in. (3 1/8 to 4 5/8)

DVP-TRAP2 can adjust 4 in. (5 3/8 to 9 3/8)

SLP-TRAP1 can adjust 1 5/8 in. (3 1/8 to 4 3/4)

SLP-TRAP2 can adjust 4 in. (5 1/4 to 9 1/4)

DVP-HPC1 can adjust 2 1/8 in. (4 1/4 to 6 3/8)

DVP-HPC2 can adjust 4 1/8 in. (6 3/8 to 10 1/2)

G. Shrouds (Optional)

HHT Shrouds

- You may install a shroud with this fireplace. See Section 12.B for a list of UL Listed shrouds. Follow the instructions included with these optional components

Field Constructed Shrouds

WARNING! Risk of Fire! Shrouds must be constructed as specified. Improper construction may overheat chase top.

- Chase top shrouds may be field constructed where permitted by regional building codes.

NOTICE: Some regional codes require an agency-Listed shroud. Consult your local building officials.

- The following field constructed shroud designs have been tested for Hearth Technologies fireplace systems and termination caps.
- The shrouds must be constructed from a minimum .018 in. (26 ga) thick aluminized steel.
- The wire mesh is optional but recommended and must be .018 in. thick minimum, 1/2 in. mesh.

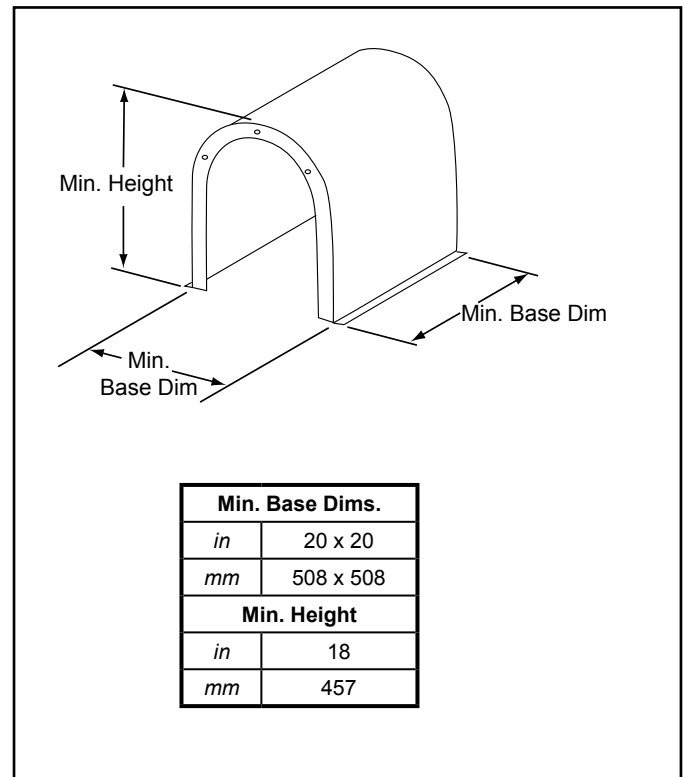

Figure 7.18 Mailbox Style Shroud Dimensions

Open Top Shroud (may be used with DVP-TV, DVP-TVHW, SLP-TVHW)

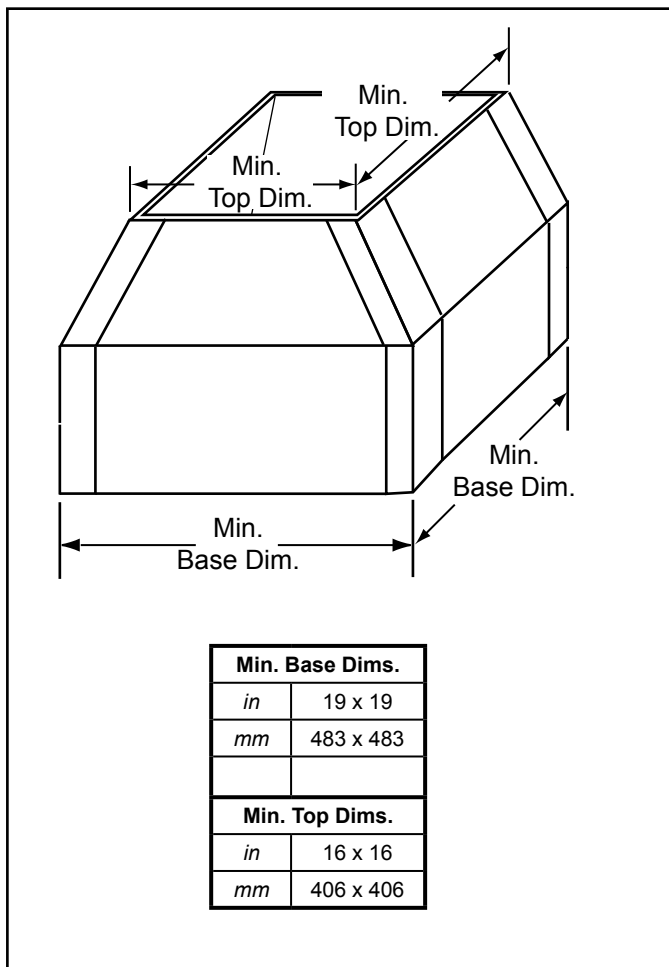

Figure 7.17 Open Top Shroud Dimensions

Roofed Style Shroud (may be used with DVP-TV, DVP-TVHW, SLP-TVHW)

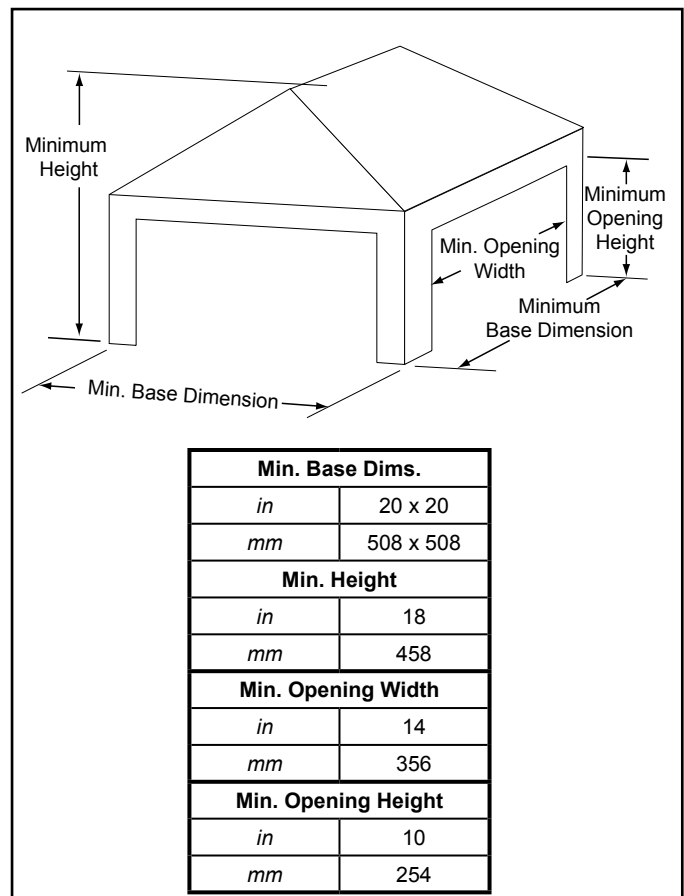

Figure 7.19 Roofed Style Shroud Dimensions

8 Electrical Information

A. General Information

WARNING! Risk of Shock or Explosion! DO NOT wire 110-120 VAC to the valve or to the appliance wall switch. Incorrect wiring will damage controls.

NOTICE: This appliance must be electrically wired and grounded in accordance with local codes or, in the absence of local codes, with **National Electric Code ANSI/NFPA 70-latest edition or the Canadian Electric Code CSA C22.1.**

- Wire the appliance junction box to unswitched 110-120 VAC. This is required for use of optional accessories (standing pilot ignition) or proper operation of the appliance (Intellifire ignition).
- A 110-120 VAC circuit for this product must be protected with ground-fault circuit-interrupter protection, in compliance with the applicable electrical codes, when it is installed in locations such as in bathrooms or near sinks.
- Low voltage and 110-120 VAC voltage cannot be shared within the same wall box.

Accessories Requirements

- This appliance may be used with a wall switch, wall mounted thermostat and/or a remote control.

Wiring for optional Hearth & Home Technologies approved accessories should be done now to avoid reconstruction. Follow instructions that come with those accessories.

- Hearth & Home Technologies recommends that IntelliFire™ Plus wireless controls be used for their features and functionality with the IntelliFire™ Plus ignition system.
- A standard ON/OFF switch is compatible.

Electrical Service and Repair

WARNING! Risk of Shock! Label all wires prior to disconnection when servicing controls. Wiring errors could cause improper and dangerous operation. Verify proper operation after servicing.

WARNING! Risk of Shock! Replace damaged wire with type 105° C rated wire. Wire must have high temperature insulation.

Junction Box Installation

If the box is being wired from the **OUTSIDE** of the appliance:

- Remove the cover plate located on the outer shell - right side (see Figure 8.1).
- Install the supplied Romex™ connector in the cover plate.
- Make all necessary wire connections and reattach the cover plate to the outer shell.

If the box is being wired from the **INSIDE** of the appliance:

- Remove the screw attaching the junction box/receptacle to the outer shell, rotate the junction box inward to disengage it from the outer shell (see Figure 8.1).
- Pull the electrical wires from outside the appliance through the opening into the valve compartment and secure wires with a Romex connector. See Figure 8.1.
- Make all necessary wire connections to the junction box/receptacle and reattach the junction box/receptacle to the outer shell.

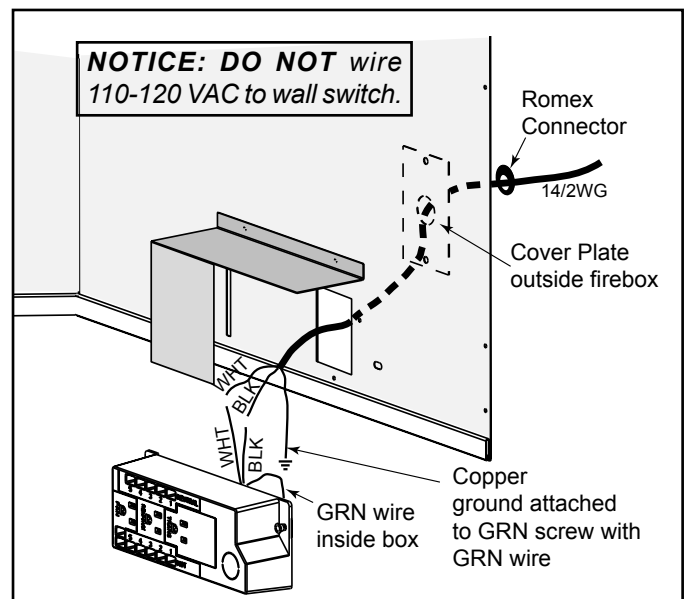

Figure 8.1 Junction Box Detail

B. Wiring Requirements

IntelliFire™ Plus Ignition System Wiring

- Wire the appliance junction box to 110-120 VAC for proper operation of the appliance.

WARNING! Risk of Shock or Explosion! DO NOT wire IPI controlled appliance junction box to a switched circuit. Incorrect wiring will override IPI safety lockout.

- Refer to Figure 8.2, IPI Wiring Diagram.
- This appliance is equipped with an IntelliFire™ Plus control valve which operates on a 6 volt/1.5 AMP system.
- Plug the 6 volt transformer plug into the appliance junction box to supply power to the unit OR install 4 AA cell batteries (not included) into the battery pack before use.

NOTICE: Batteries should only be used as a power source in the event of an emergency power outage. Batteries should not be used as a primary long-term power source. Battery polarity must be correct when installing batteries.

Do not store batteries in the battery pack when the appliance is powered by the 6 volt transformer connected to permanent electrical service.

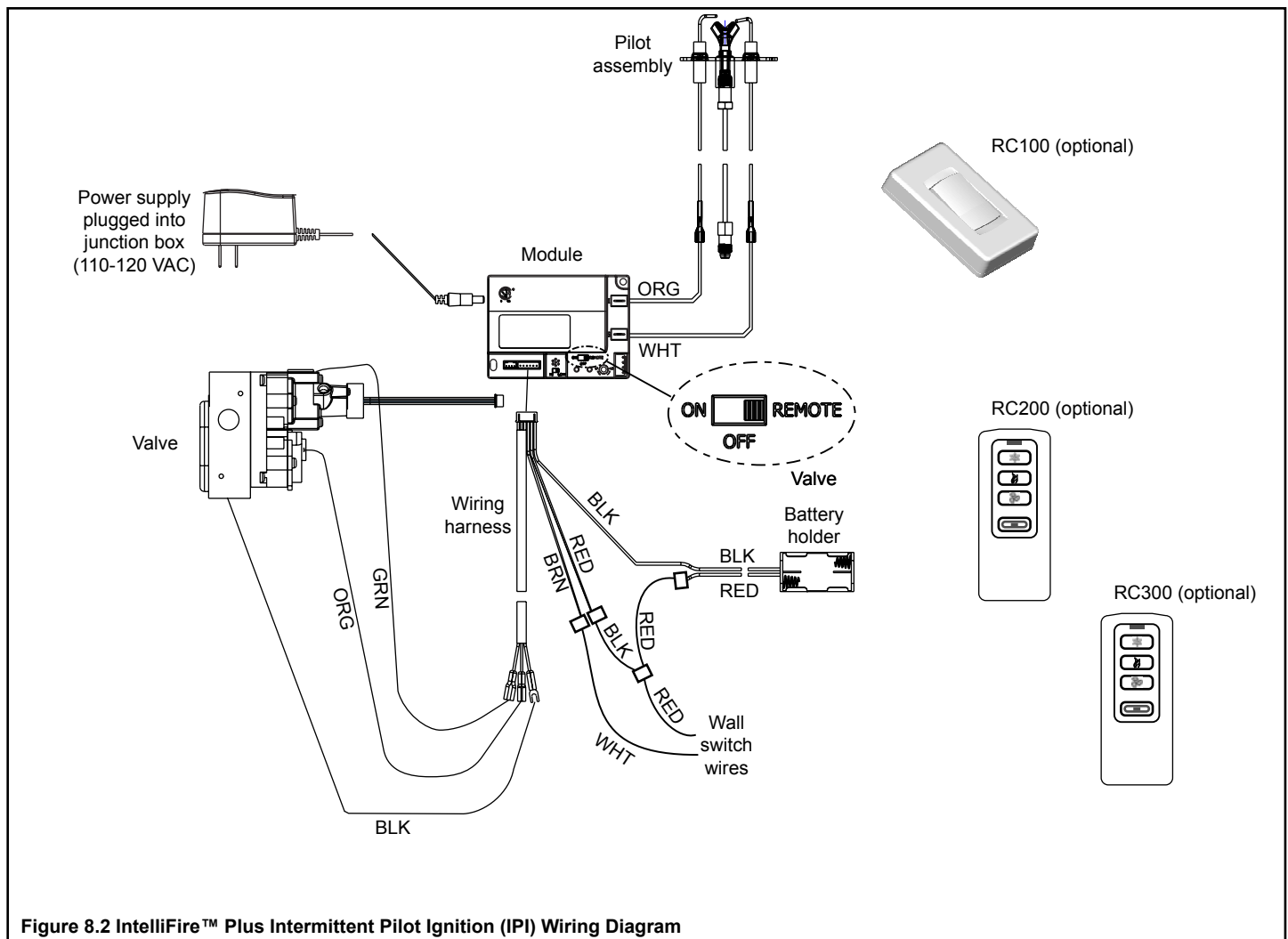

Wall Switch Installation for Fan (Optional)

If the box is being wired to a wall mounted switch for use with a fan. See Figure 8.3:

- The power supply for the appliance must be brought into a switch box.
- The power can then be supplied from the switch box to the appliance using a minimum of 14-3 with ground wire.
- At the switch box connect the black (hot) wire and red (switch leg) wire to the wall switch as shown.
- At the appliance connect the black (hot), white (neutral) and green (ground) wires to the junction box as shown.
- Add a 1/4 in. insulated female connector to the red (switch leg) wire, route it through the knockout in the face of the junction box, and connect to the top fan switch connector (1/4 in. male) as shown.

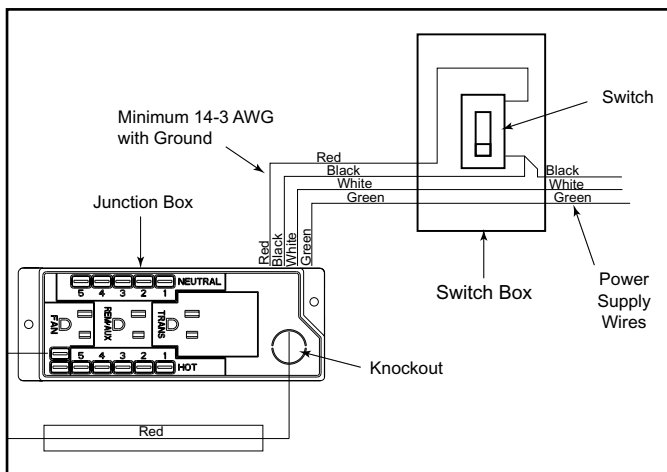

Figure 8.3 Junction Box Wired to Wall Switch or BC10

9 Gas Information

A. Fuel Conversion

- Make sure the appliance is compatible with available gas types.
- Conversions must be made by a qualified service technician using Hearth & Home Technologies specified and approved parts.

B. Gas Pressure

- Optimum appliance performance requires proper input pressures.
- Gas line sizing requirements will be determined in ANSI Z223.1 National Fuel Gas Code in the USA and CAN/CGA B149 in Canada.
- Pressure requirements are:

Gas Pressure	Natural Gas	Propane
Minimum inlet pressure	5.0 in. w.c.	11.0 in. w.c.
Maximum inlet pressure	10.0 in. w.c.	13.0 in. w.c.
Manifold pressure	3.5 in. w.c.	10.0 in. w.c.

WARNING! Risk of Fire or Explosion! High pressure will damage valve. Low pressure could cause explosion.

- Verify inlet pressures. Verify minimum pressures when other household gas appliances are operating.
- Install regulator upstream of valve if line pressure is greater than 1/2 psig.

▲ WARNING	
	<p>Fire Risk. Explosion Hazard. High pressure will damage valve.</p> <ul style="list-style-type: none">• Disconnect gas supply piping BEFORE pressure testing gas line at test pressures above 1/2 psig.• Close the manual shutoff valve BEFORE pressure testing gas line at test pressures equal to or less than 1/2 psig.

Note: Have the gas supply line installed in accordance with local codes, if any. If not, follow ANSI Z223.1. Installation should be done by a qualified installer approved and/or licensed as required by the locality. (In the Commonwealth of Massachusetts installation must be performed by a licensed plumber or gas fitter).

Note: A listed (and Commonwealth of Massachusetts approved) 1/2 in. (13 mm) T-handle manual shut-off valve and flexible gas connector are connected to the 1/2 in. (13 mm) control valve inlet.

- **If substituting for these components, please consult local codes for compliance.**

C. Gas Connection

- Refer to Reference Section 3 for location of gas line access in appliance.
- Gas line may be run through knockout(s) provided.
- The gap between supply piping and gas access hole may be caulked with caulk with a minimum of 300 °F continuous exposure rating or stuffed with non-combustible, unfaced insulation to prevent cold air infiltration.
- Ensure that gas line does not come in contact with outer wrap of the appliance. Follow local codes.
- Pipe incoming gas line into valve compartment.
- Connect incoming gas line to the 1/2 in. (13 mm) connection on manual shutoff valve.

WARNING! Risk of Fire or Explosion! Support control when attaching pipe to prevent bending gas line.

- A small amount of air will be in the gas supply lines.

WARNING! Risk of Fire or Explosion! Gas build-up during line purge could ignite.

- Purge should be performed by qualified service technician.
- Ensure adequate ventilation.
- Ensure there are no ignition sources such as sparks or open flames.

Light the appliance. It will take a short time for air to purge from lines. When purging is complete the appliance will light and operate normally.

WARNING! Risk of Fire, Explosion or Asphyxiation! Check all fittings and connections with a non-corrosive commercially available leak-check solution. **DO NOT** use open flame. Fittings and connections could have loosened during shipping and handling.

WARNING! Risk of Fire! DO NOT change valve settings. This valve has been preset at the factory.

D. High Altitude Installations

NOTICE: If the heating value of the gas has been reduced, these rules do not apply. Check with your local gas utility or authorities having jurisdiction.

When installing above 2000 feet elevation:

- In the USA: Reduce input rate 4% for each 1000 feet above 2000 feet.
- In CANADA: Input ratings are certified without a reduction of input rate for elevations up to 4500 feet (1370 m) above sea level. Please consult provincial and/or local authorities having jurisdiction for installations at elevations above 4500 feet (1370 m).

Check with your local gas utility to determine proper orifice size.

E. Air Shutter Setting

Air shutter setting should be adjusted by a qualified installer at the time of installation.

- The air shutter is set at the factory for minimum vertical vent run. It may need to be adjusted for other venting scenarios.
- Adjust air shutter for longer vertical runs. See Figure 9.1. Turn the thumbscrew to open or close the air shutter. It may be necessary to use a pliers or crescent wrench to adjust the shutter.

Note: Adjust air shutter after flame has reached full maturity (approximately 20-40 minutes).

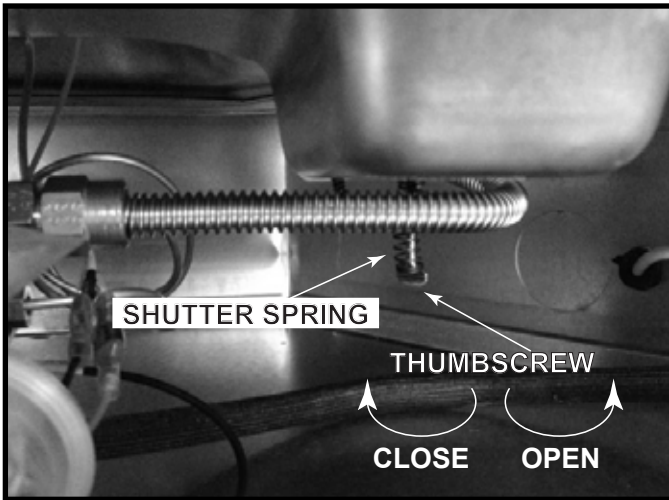

Figure 9.1 Adjusting Air Shutter

Note: The air shutter is equipped with a compression spring that helps to maintain the shutter position during transportation. It may be necessary to relieve this spring pressure on the thumb screw to adjust the shutter.

10 Finishing

A. Facing Material

- Metal front faces may be covered with non-combustible materials only.
- Facing and/or finishing materials must not interfere with air flow through louvers, operation of louvers or doors, or access for service.
- Facing and/or finishing materials must never overhang into the glass opening.
- Observe all clearances when applying combustible materials.

Note: If using the optional finishing trim for the Modern Front facing, finish wall material must not be installed within 3 in. (76 mm) of the fireplace opening. See Figure 14.5.

- Seal joints between the finished wall and appliance top and sides using a 300 °F minimum sealant. Refer to Figure 10.2.

WARNING! Risk of Fire! DO NOT apply combustible materials beyond the minimum clearances. Comply with all minimum clearances to combustibles as specified in this manual. Overlapping materials could ignite and will interfere with proper operation of doors and louvers.

NOTICE: Surface temperatures around the appliance will become warm while the appliance is in operation. Ensure finishing materials used for all surfaces (floor, walls, mantels, etc.) will withstand temperatures up to 190°F.

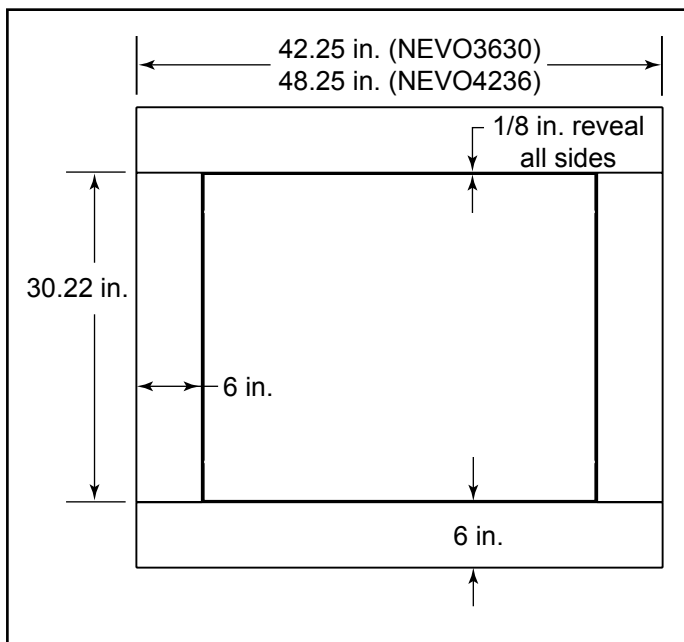

Figure 10.1 Marble/Granite Cut Dimensions

- Figure 10.1 shows the dimensions for cutting marble/granite if the optional Finishing Trim is not used.
- The dimensions given assume a 1/8 in. reveal around the fireplace opening.

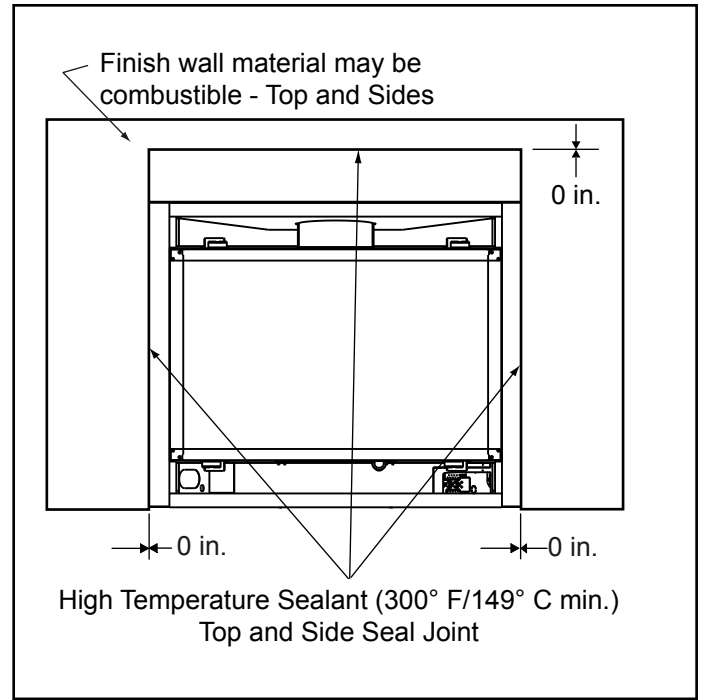

Figure 10.2 Non-combustible Facing Diagram

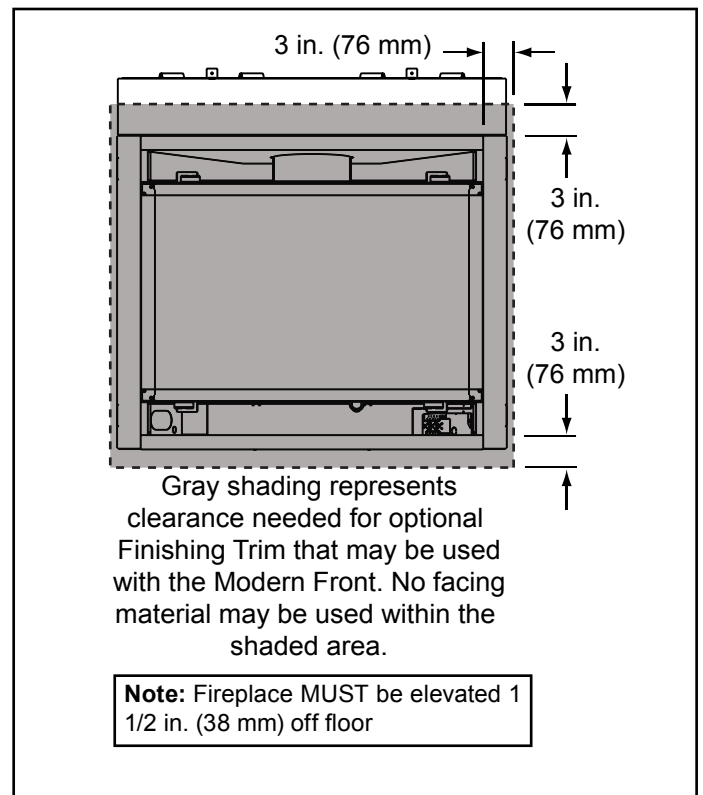

Figure 10.3 Clearance for Optional Finishing Trim (Modern Front)

B. Mantel and Wall Projections

WARNING! Risk of Fire! Comply with all minimum clearances as specified. Framing closer than the minimums listed must be constructed entirely of non-combustible materials (i.e., steel studs, concrete board, etc.).

Note: Mantel Measurement is taken from top of the opening, NOT the top of the fireplace.

Combustible Mantels

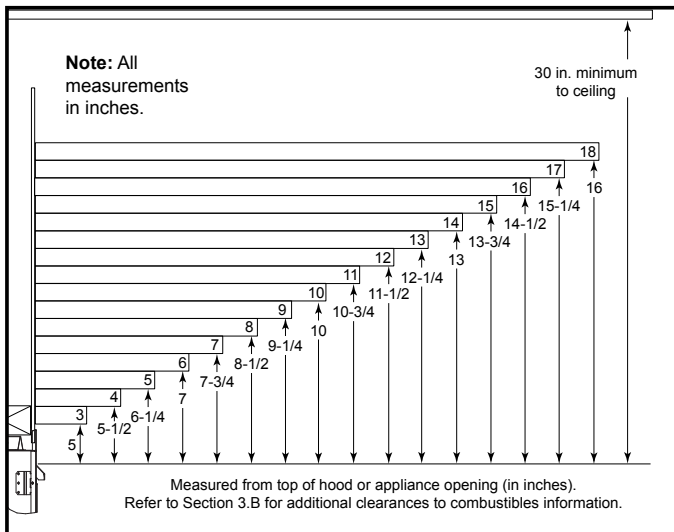

Figure 10.2 Minimum Vertical and Maximum Horizontal Dimensions of Combustibles

Combustible or Non-Combustible Mantel Legs or Wall Projections

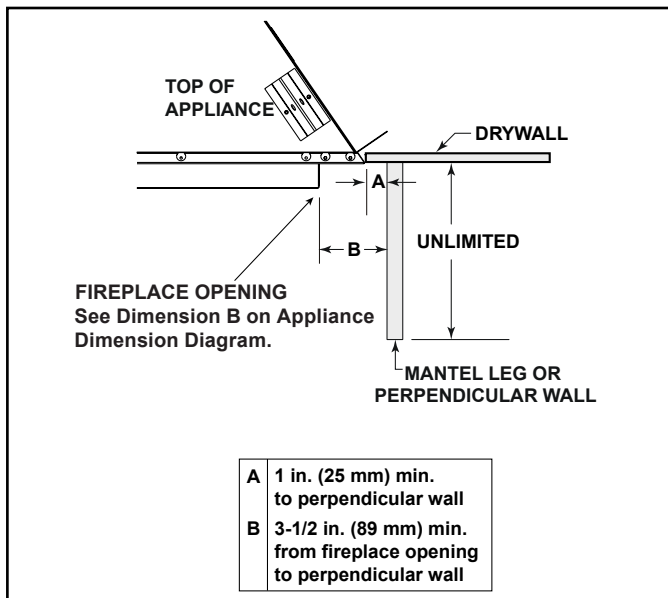

Figure 10.3 Combustible Mantel Leg or Wall Projections (Acceptable on both sides of opening)

C. Decorative Front Dimensions for Finishing

Only decorative fronts certified for use with this appliance model may be used. Contact your dealer for a list of decorative fronts that may be used. The finishing material thicknesses allowed are noted below.

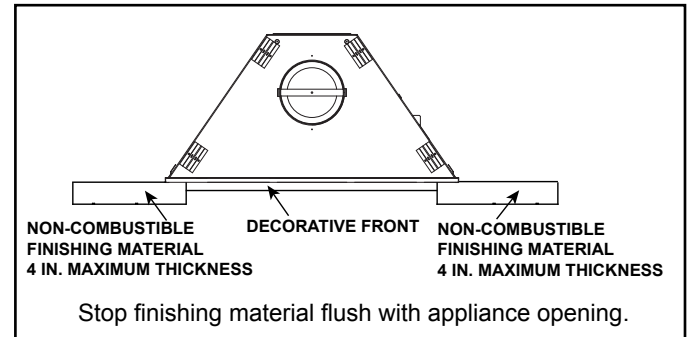

Figure 10.4 Non-Combustible Finishing Material

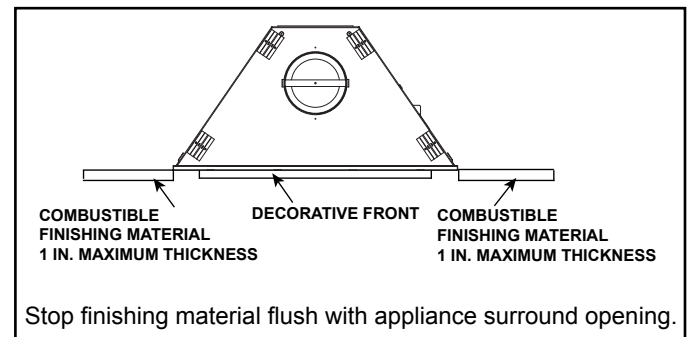

Figure 10.5 Combustible Finishing Material

11 Appliance Setup

A. Remove the Packaging

Remove the shrink film, corrugated top cap, bottom cap and column protectors from the appliance. The appliance should look as shown in Figure 11.1.



Figure 11.1 Appliance Unwrapped

B. Remove Fixed Glass Assembly

WARNING! Risk of Asphyxiation! Handle fixed glass assembly with care. Inspect the gasket to ensure it is undamaged and inspect the glass for cracks, chips or scratches.

- **DO NOT** strike, slam or scratch glass.
- **DO NOT** operate fireplace with glass removed, cracked, broken or scratched.
- Replace as a complete assembly.
 - Pull the four (two upper and two lower) glass assembly latches out of the groove on the glass frame. Refer to Figure 11.1.
 - Remove the glass assembly from the appliance.

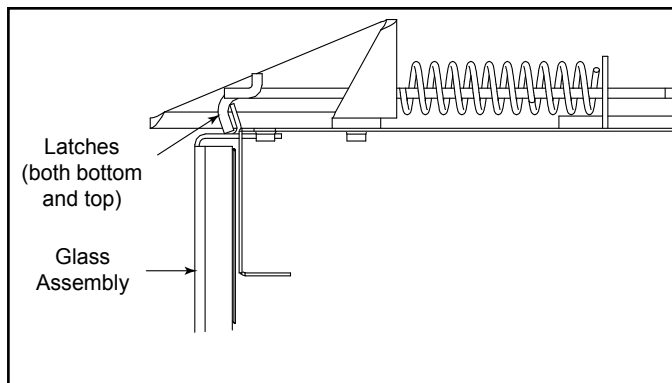

Figure 11.2 Fixed Glass Assembly

C. Remove the Shipping Materials

Remove shipping materials from inside or underneath the firebox.

- The splatter guard is a piece of corrugated material used to protect the appliance during the installation process before finishing work on the whole hearth is complete. Splatter guards may be factory installed or accompany the door of the unit, depending on the fireplace model. Splatter guards must be removed before appliance is fired.

WARNING! Risk of Fire! Close the ball valve before installing the splatter guard to prevent accidental lighting. Remove the splatter guard before lighting the appliance.

D. Remove Glass Media Package

The glass media package is shipped inside the firebox. Refer to Figure 11.1.

E. Clean the Appliance

Clean/vacuum any sawdust that may have accumulated inside the firebox or underneath in the control cavity.

F. Install Glass Media

WARNING! Risk of Explosion! Follow glass media placement instructions.

- DO NOT place glass media in pilot opening.
- DO NOT place glass media where they might fall into pilot opening.
- DO NOT use any media other than the glass media supplied with this fireplace.
- DO NOT place more than one layer of glass media on top of burner.

Improperly placed glass media interferes with proper burner operation. Delayed ignition could occur.

WARNING! Choking Hazard! Keep glass media out of reach of children.

Cleaning the Glass Media

During shipment of the glass media, dust and debris can accumulate. We recommend the glass media be rinsed thoroughly with water to remove dust and small glass particles.

- Place the glass media into a bucket and rinse thoroughly with water.
- Allow the glass media to dry before installing it into the fireplace.

Install the Glass Media

- Remove the screws holding the glass media placement jig. Leave the jig in place until the glass media is placed.



Figure 11.3 Remove Screws from Jig

- Open the bag of glass media and place on the burner/hearth pan area.
- Spread the glass media over the entire area. **Make sure glass media is only one layer thick on top of the burner.**

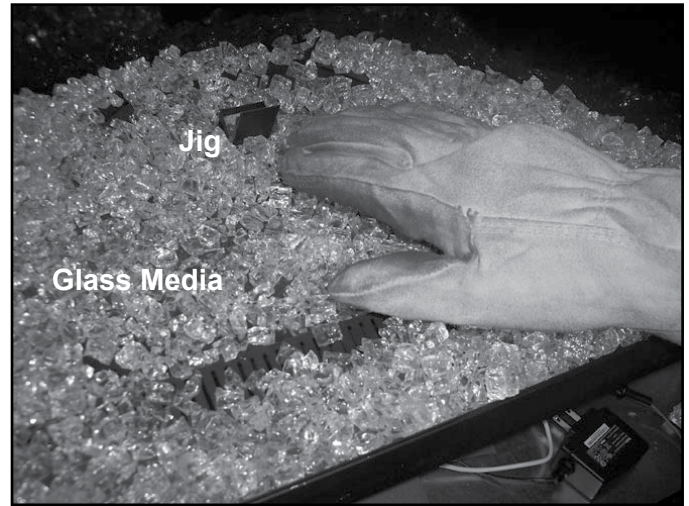

Figure 11.4 Place & Spread Glass Media

- Remove the glass media placement jig.



Figure 11.5 Remove Jig

- Make sure the area in front of the pilot remains free of glass media.



Figure 11.6 Pilot Open & Glass-Media-Free

G. Install Fixed Glass Assembly

WARNING! Risk of Asphyxiation! Handle fixed glass assembly with care. Inspect the gasket to ensure it is undamaged and inspect the glass for cracks, chips or scratches.

- **DO NOT** strike, slam or scratch glass.
- **DO NOT** operate fireplace with glass removed, cracked, broken or scratched.
- Replace as a complete assembly.
- Set the glass panel on the lower two or four glass assembly latches, ensuring the glass panel is centered in the opening.
- Replace glass latches. See Figure 11.2.

H. Install Decorative Front

WARNING! Risk of Fire! Install **ONLY** decorative fronts approved by Hearth & Home Technologies. Unapproved doors or fronts could cause fireplace to overheat.

This fireplace has been supplied with an integral barrier to prevent direct contact with the fixed glass panel. DO NOT operate the fireplace with the barrier removed.

Contact your dealer or Hearth & Home Technologies if the barrier is not present or help is needed to properly install one.

For more information refer to the instructions supplied with your decorative front.

12 Reference Materials

A. Vent Components Diagrams

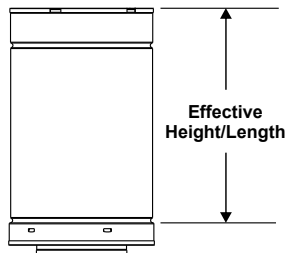

DVP Pipe (see chart)

Pipe	Effective Length	
	Inches	Millimeters
DVP4	4	102
DVP6	6	152
DVP12	12	305
DVP24	24	610
DVP36	36	914
DVP48	48	1219
DVP6A	3 to 6	76 to 152
DVP12A	3 to 12	76 to 305

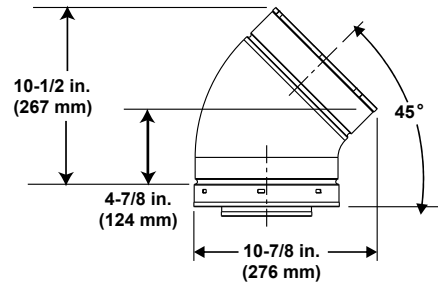

DVP45 (45° Elbow)

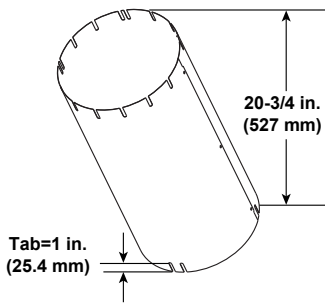

Finished Height: 19-3/4 in./502 mm
UNIV-AS2 (Attic Insulation Shield)

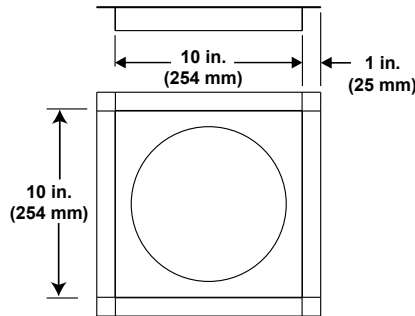

DVP-FS (Ceiling Firestop)

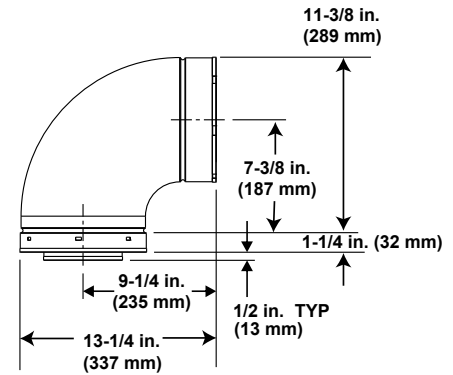

DVP90ST (90° Elbow)

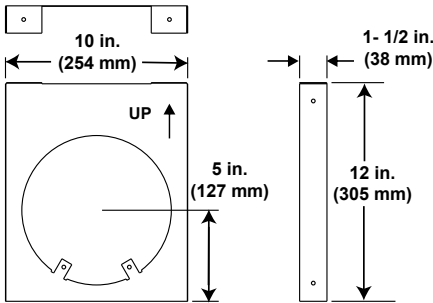

DVP-HVS (Vent Support)

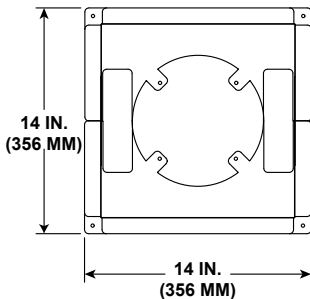

DVP-RDS
ROOF DECK INSULATION SHIELD

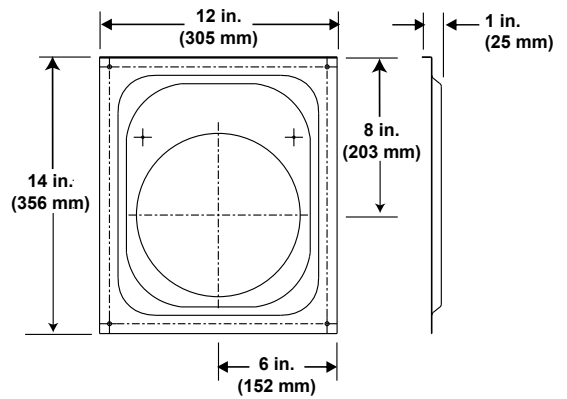
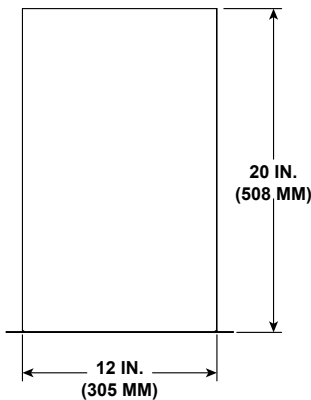

DVP-WS (Wall Shield Firestop)

Figure 12.1 DVP Vent Components

A. Vent Components Diagrams (continued)

Note: Heat shields MUST overlap by a minimum of 1-1/2 in. (38 mm). The heat shield is designed to be used on a wall 4 in. to 7-1/4 in. (102 mm to 184 mm) thick. If wall thickness is less than 4 in. (102 mm) the existing heat shields must be field trimmed. If wall thickness is greater than 7-1/4 in. (184 mm) a DVP-HSM-B will be required.

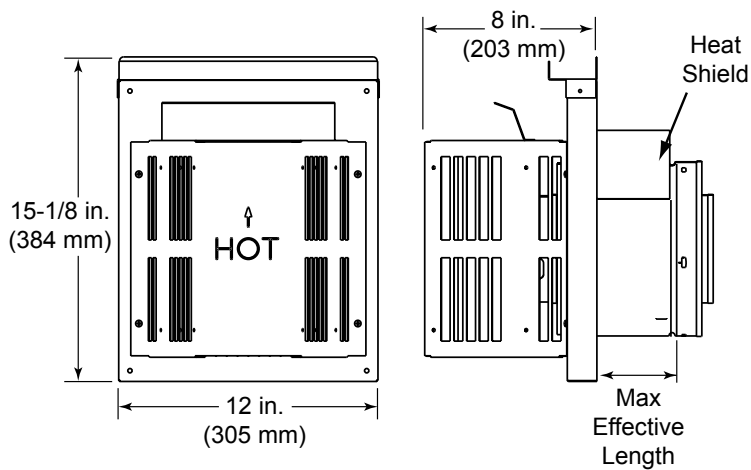

DVP-TRAP
Horizontal Termination Cap

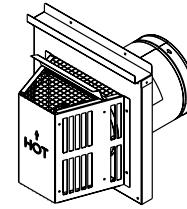

Term Cap	Minimum Effective Length	Maximum Effective Length
Trap1	3-1/8 in.	4-5/8 in.
	79 mm	117 mm
Trap2	5-3/8 in.	9-3/8 in.
	137 mm	238 mm

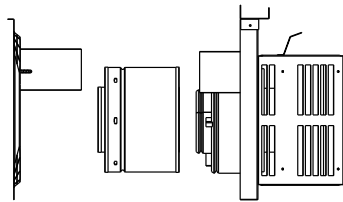

DVP-TRAP1

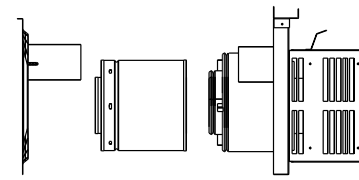

DVP-TRAP2

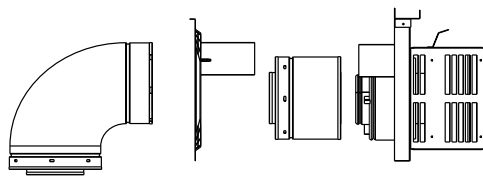

DVP-TRAPK1

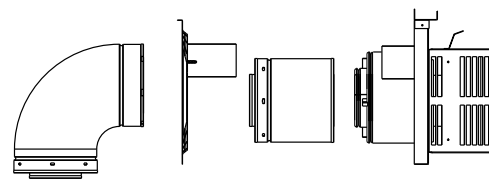

DVP-TRAPK2

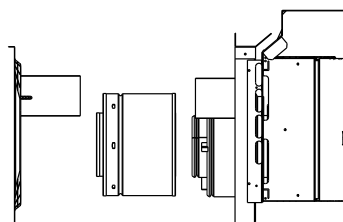

DVP-HPC1

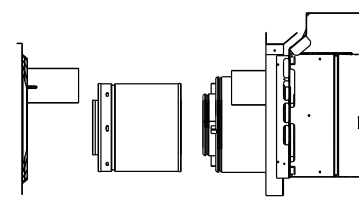

DVP-HPC2

Figure 12.2 DVP Vent Components

A. Vent Components Diagrams (continued)

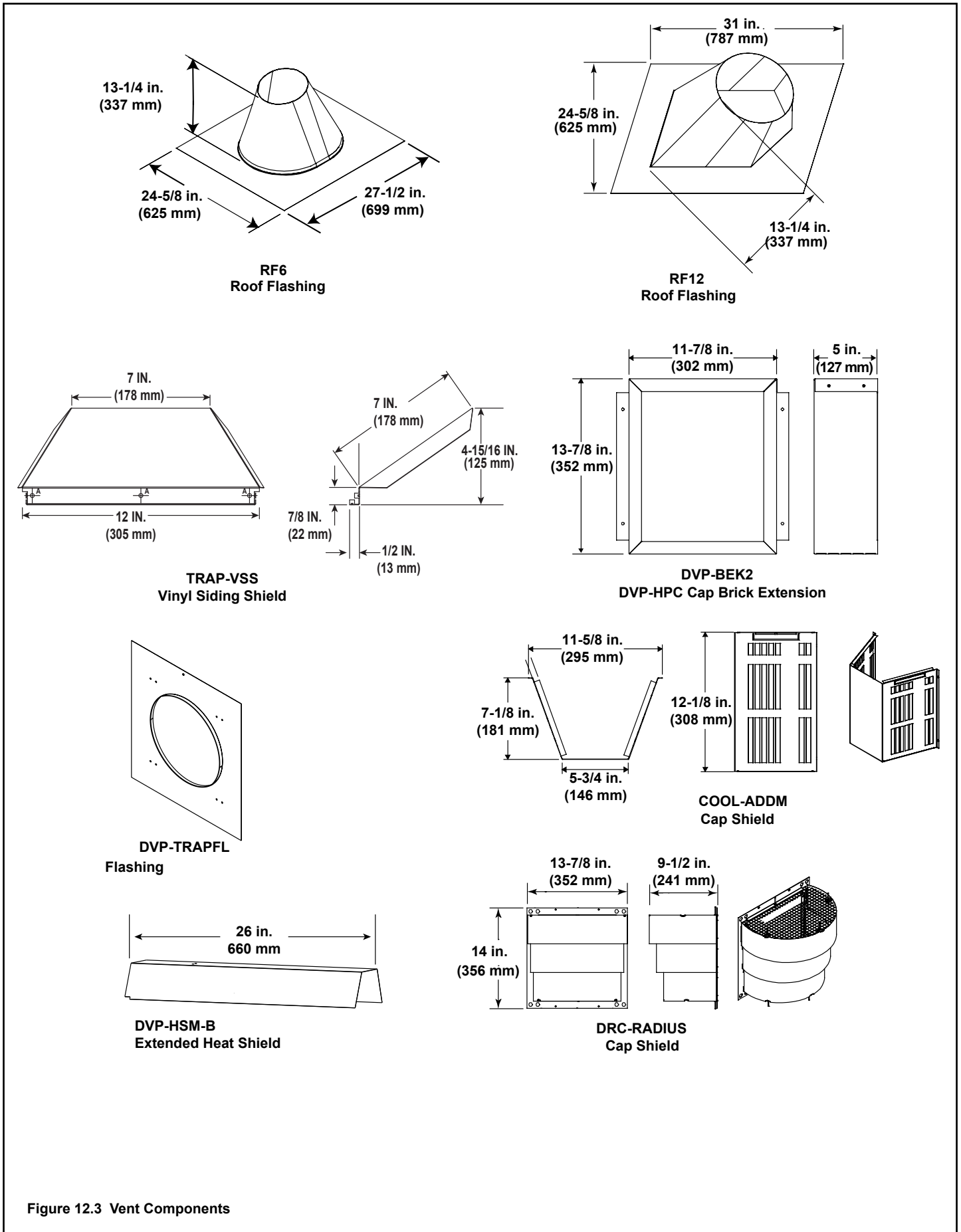
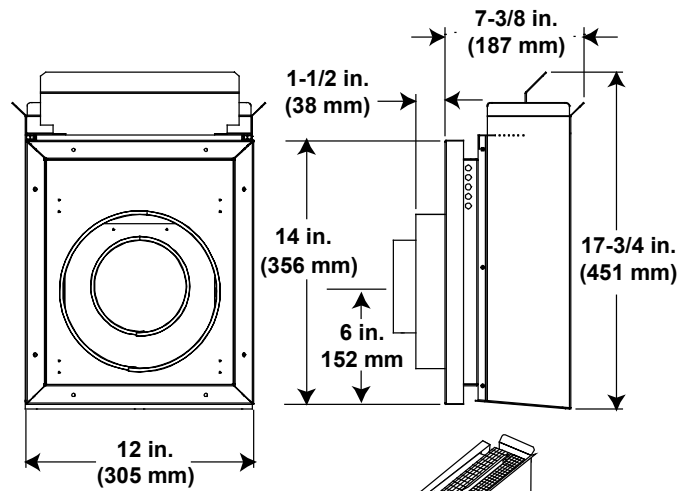
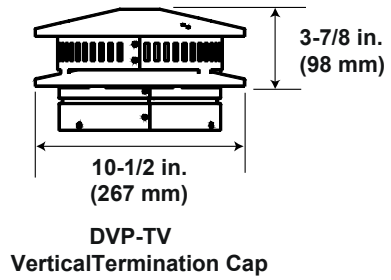
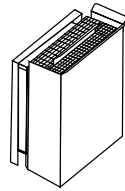

Figure 12.3 Vent Components

A. Vent Components Diagrams (continued)



DVP-TB1
Basement Vent Cap



DVP-TV
Vertical Termination Cap

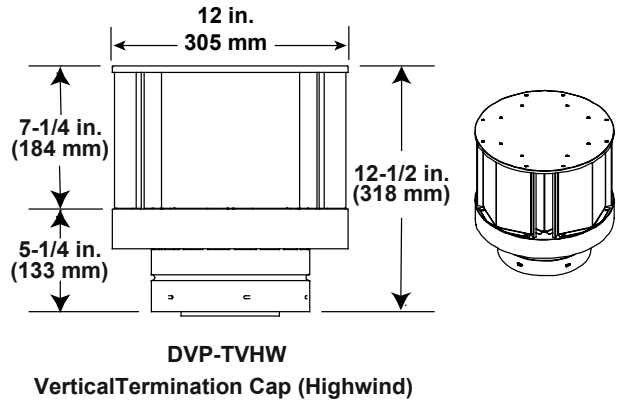
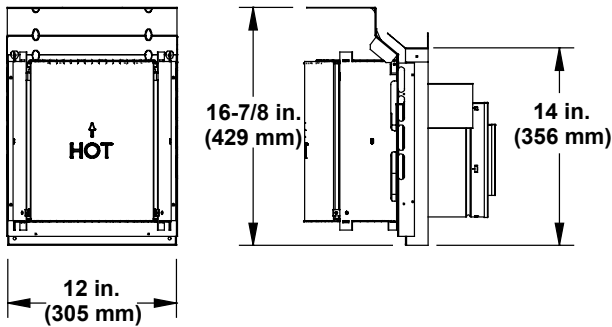

DVP-TVHW
Vertical Termination Cap (Highwind)

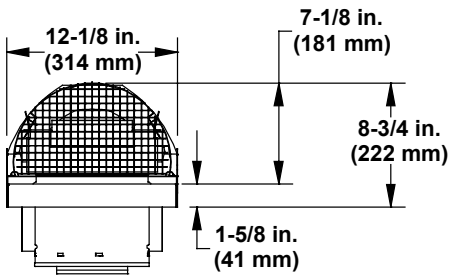

DVP-HPC
High Performance Cap

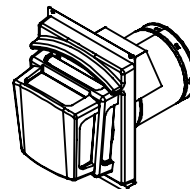
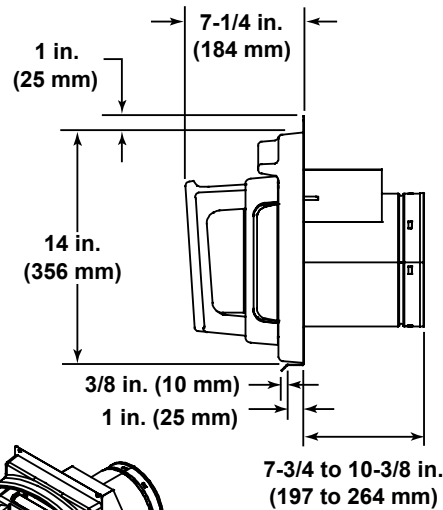

DVP-FBHT
Fire Brick Termination Cap

Figure 12.4 DVP Vent Components

A. Vent Components Diagrams (continued)

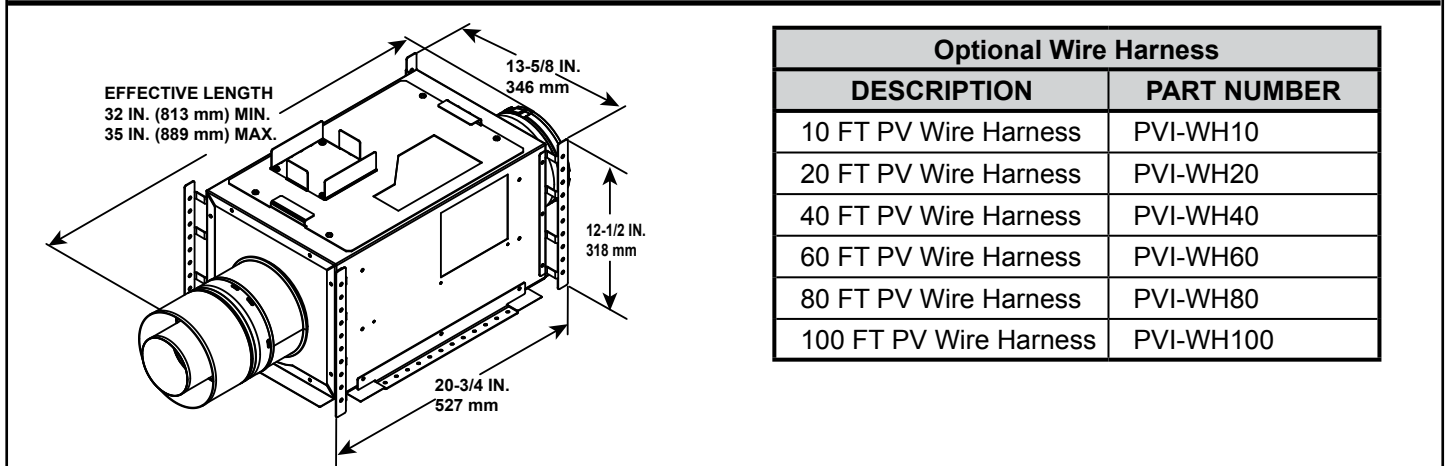
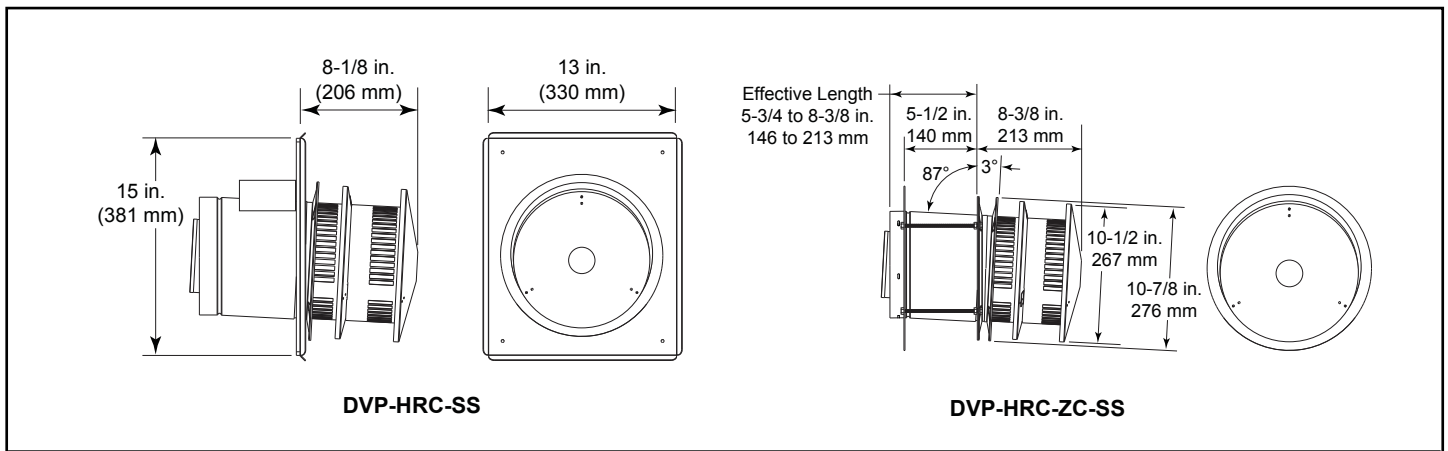

Optional Wire Harness	
DESCRIPTION	PART NUMBER
10 FT PV Wire Harness	PVI-WH10
20 FT PV Wire Harness	PVI-WH20
40 FT PV Wire Harness	PVI-WH40
60 FT PV Wire Harness	PVI-WH60
80 FT PV Wire Harness	PVI-WH80
100 FT PV Wire Harness	PVI-WH100

Note: Wire harnesses required to power the PVI-SLP-B connect to the appliance and are ordered separately from PVI-SLP-B. Contact your dealer to order.

Note: The PVI-SLP-B requires a PV-IPI-CK be installed on this appliance. The PV-IPI-CK is ordered separately from the PVI-SLP-B. Contact your dealer to order.

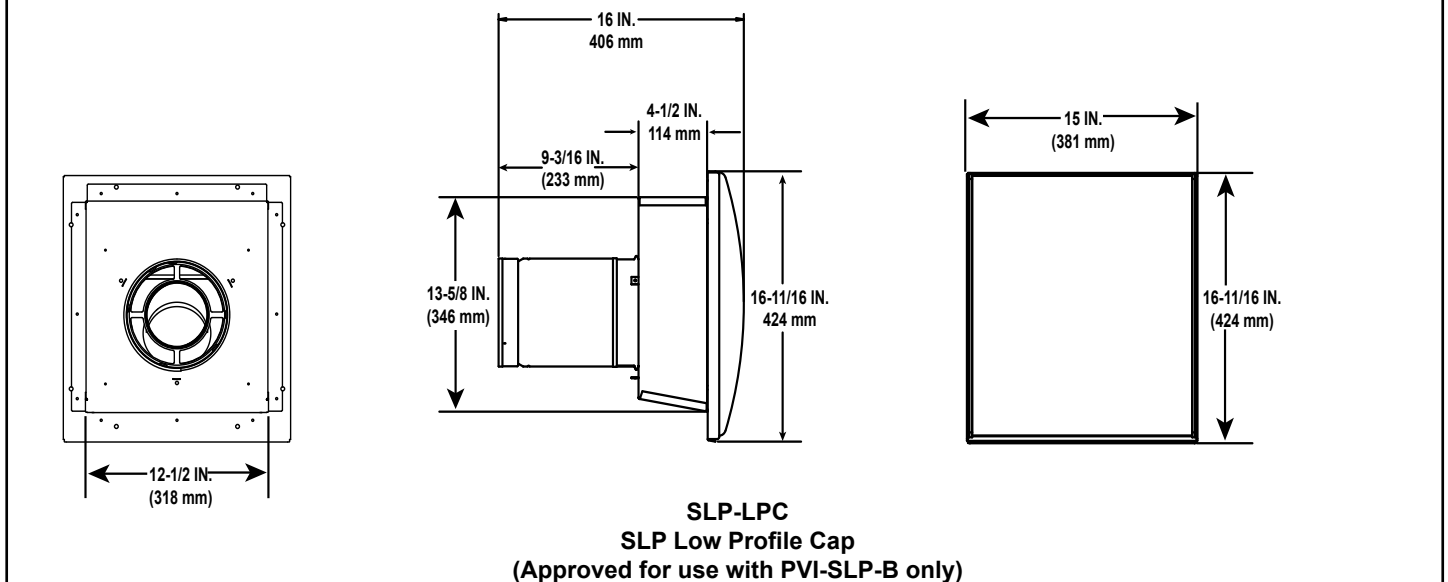
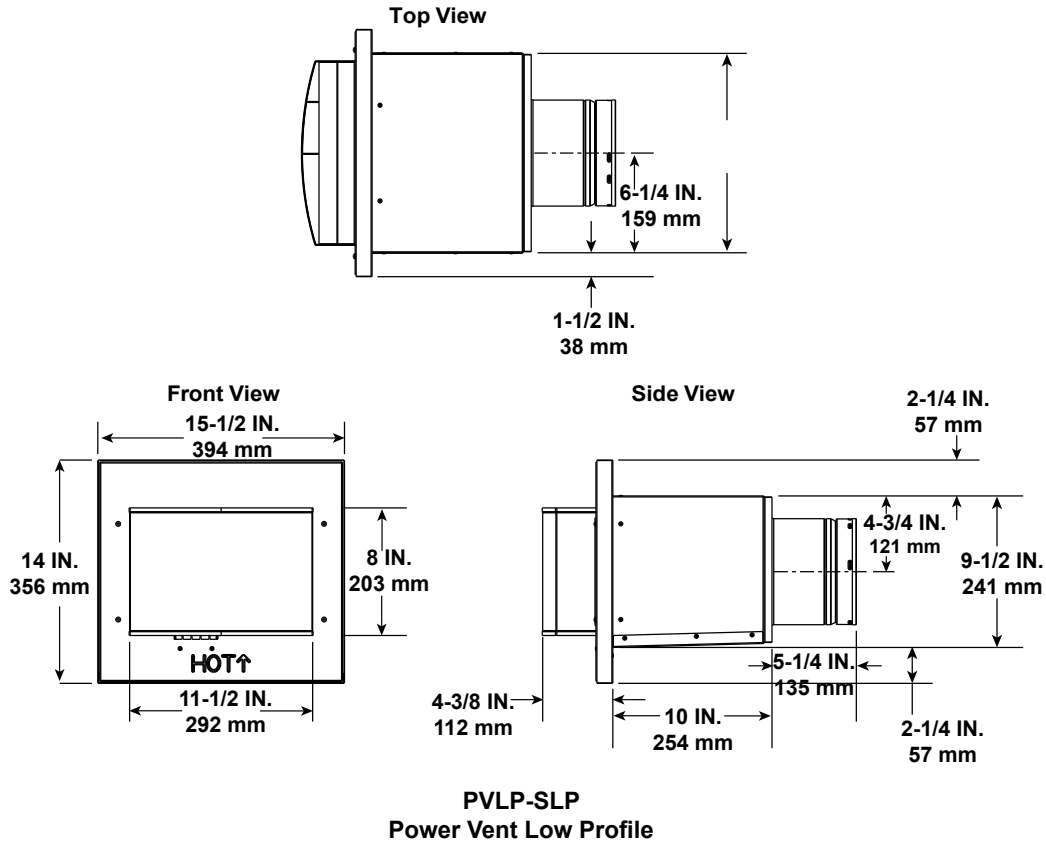

Figure 12.5 PVI-SLP-B Vent Components

A. Vent Components Diagrams (continued)



Note: Wire harnesses required to power the PVLP-SLP connect to the appliance and are ordered separately from PVLP-SLP. Contact your dealer to order.

Note: A PVLP-HS heat shield is available and sold separately. Use if the PVLP-SLP is installed in a high traffic area.

Note: The PVLP-SLP requires a PV-IPI-CK be installed on this appliance. The PV-IPI-CK is ordered separately from the PVLP-SLP. Contact your dealer to order.

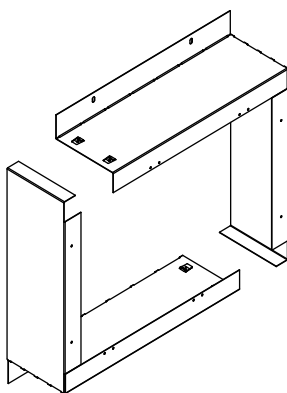

**PVLP-BEK
Brick Kit**

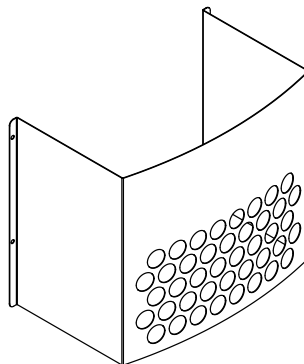

**PVLP-HS
Heat Shield**

Required Wire Harness	
DESCRIPTION	PART NUMBER
10 FT PV Wire Harness	PVI-WH10
20 FT PV Wire Harness	PVI-WH20
40 FT PV Wire Harness	PVI-WH40
60 FT PV Wire Harness	PVI-WH60
80 FT PV Wire Harness	PVI-WH80
100 FT PV Wire Harness	PVI-WH100

Figure 12.6 PVLP-SLP Vent Components

A. Vent Components Diagrams (continued)

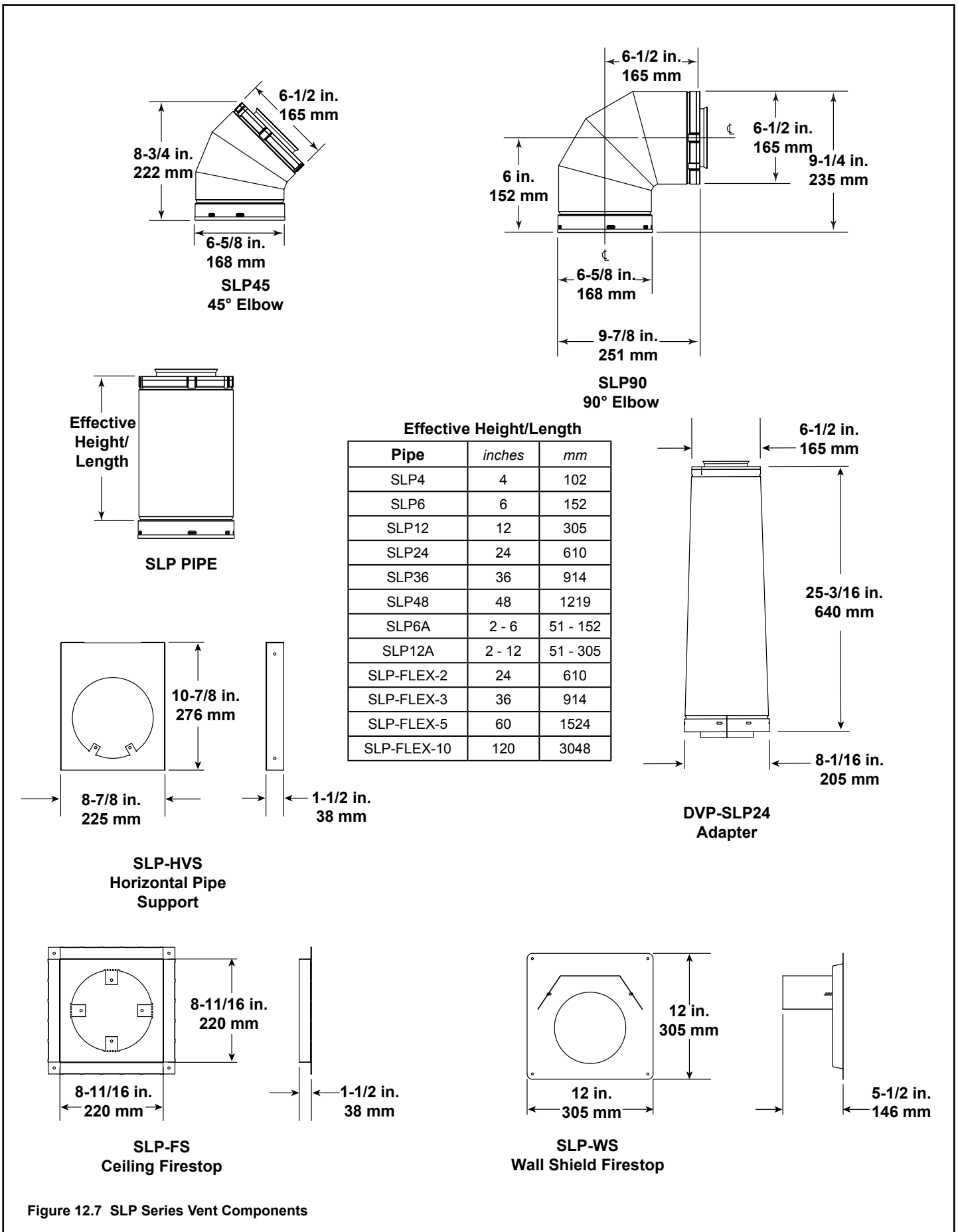
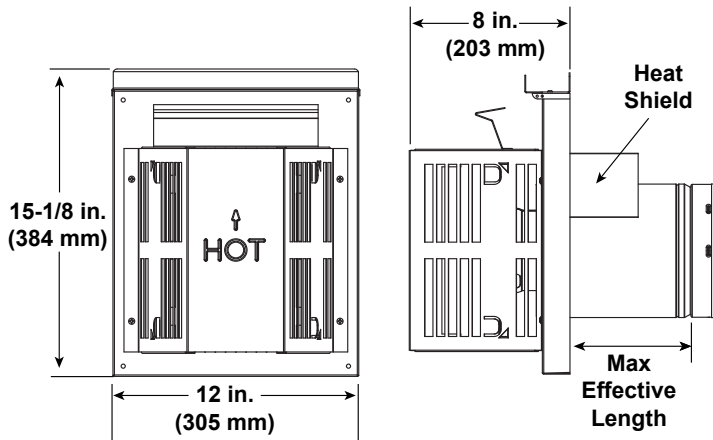

Figure 12.7 SLP Series Vent Components

A. Vent Components Diagrams (continued)

Note: Heat shields MUST overlap by a minimum of 1-1/2 in. (38 mm). The heat shield is designed to be used on a wall 4 in. to 7-1/4 in. (102 mm to 184 mm) thick. If wall thickness is less than 4 in. (102 mm) the existing heat shields must be field trimmed. If wall thickness is greater than 7-1/4 in. (184 mm) a DVP-HSM-B will be required.



SLP-TRAP
Horizontal Termination Cap

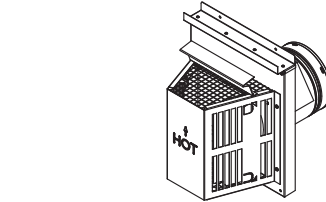

Term Cap	Minimum Effective Length	Maximum Effective Length
Trap1	3-1/8 in.	4-3/4 in.
	79 mm	121 mm
Trap2	5-1/4 in.	9-1/4 in.
	133 mm	235 mm

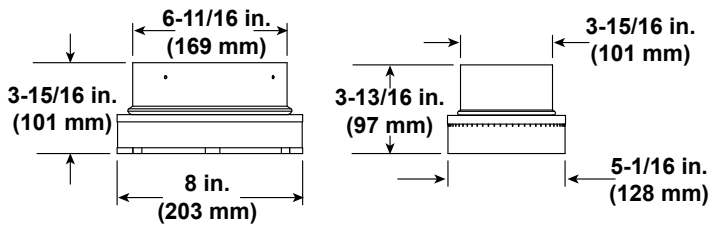

SL-2DVP
Adapter

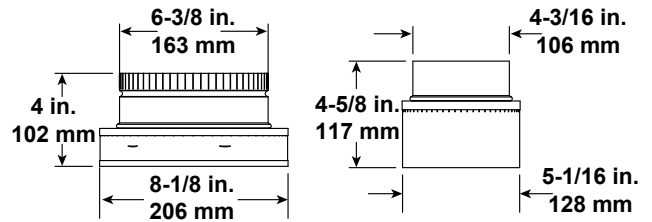

DVP-2SL
Adapter

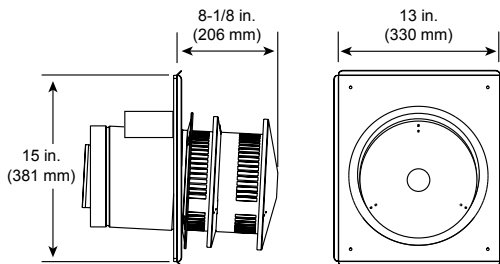

SLP-HRC-SS
Horizontal Termination Cap

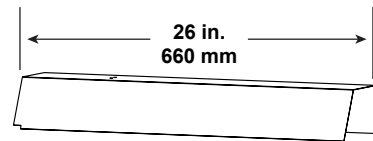

DVP-HSM-B
Extended Heat Shield

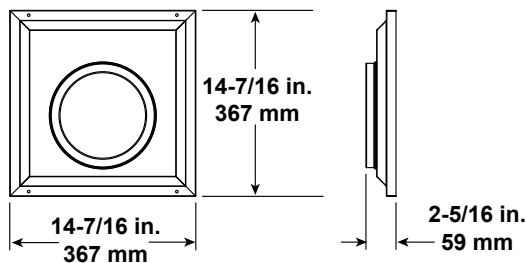

SLP-WT-BK
Wall Thimble-Black

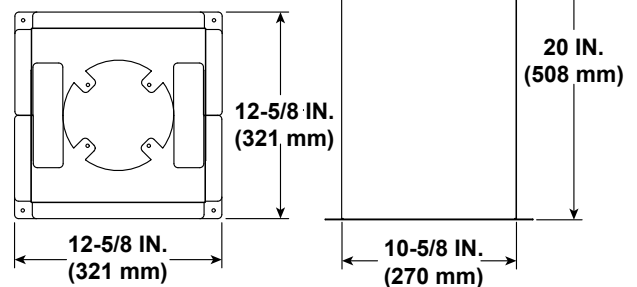

SLP-RDS
ROOF DECK INSULATION SHIELD

Figure 12.8 SLP Series Vent Components

A. Vent Components Diagrams (continued)

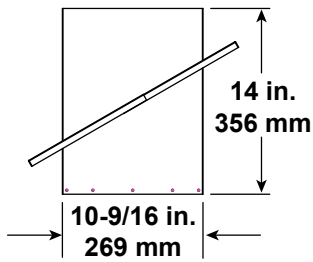

SLP-CCS-BK
Cathedral Ceiling
Support Box-Black

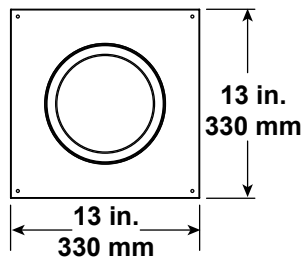

SLP-DCF-BK
Ceiling Firestop
Black

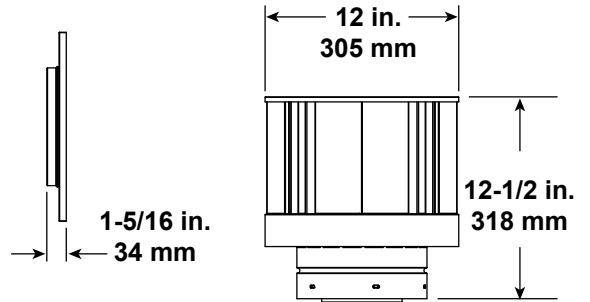

SLP-TVHW
Vertical
Termination Cap

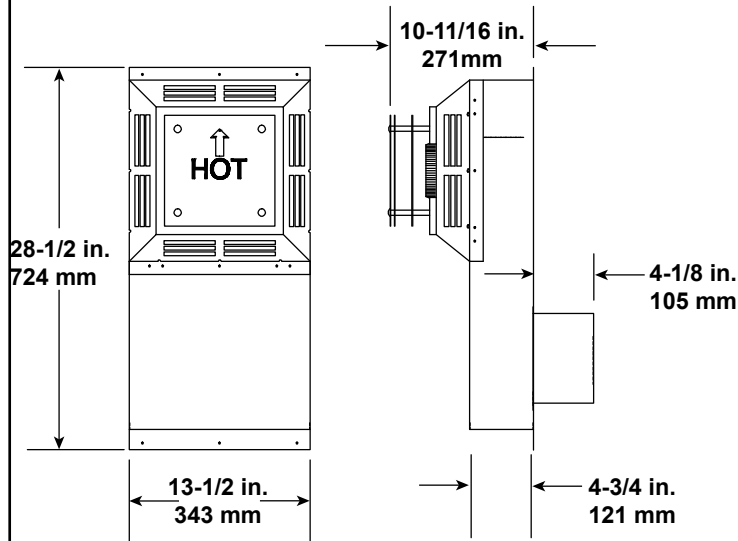

SLK-SNKD
Snorkel
Termination Cap

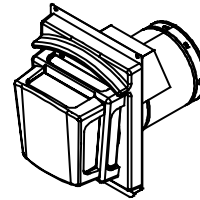
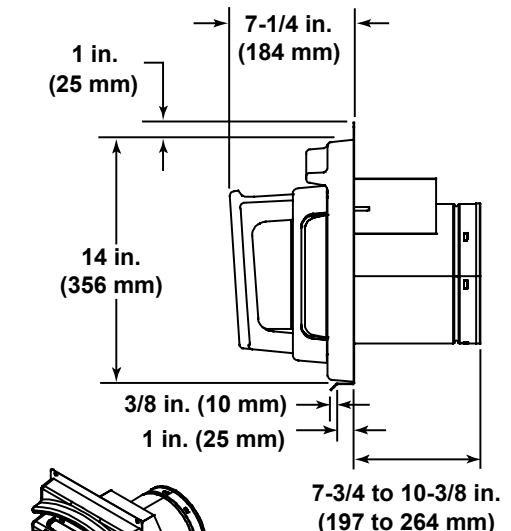

DVP-FBHT
Horizontal
Termination Cap

Figure 12.9 SLP Series Vent Components

B. Optional Components

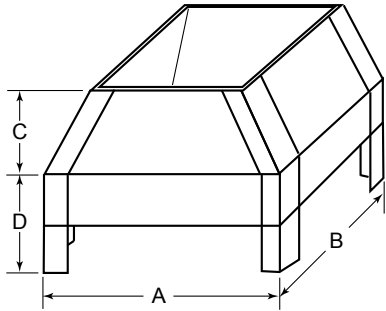

LDS33/LDS46 Decorative Shroud

Catalog #	A		B		C		D	
	in.	mm	in.	mm	in.	mm	in.	mm
LDS33	36	914	36	914	8.5	216	11	279
LDS46	48	1219	72	1829	8.5	216	11	279

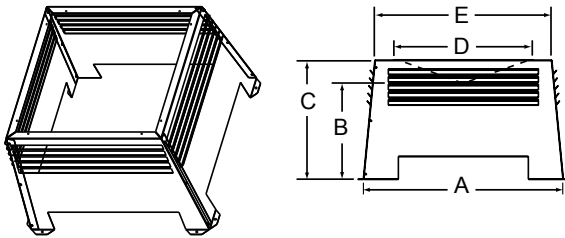

LDS-BV Decorative Shroud

Catalog #		A	B	C	E	E
LDS-BV	in.	26	12.5	15.5	22	23
	mm	660	318	394	533	584

LDSCP-M Shroud Leg Multipack
(not shown)

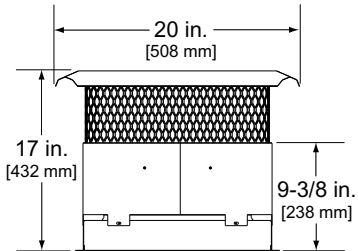

TCG375 Terra Cotta Cap

See your Heatilator dealer for a complete listing of optional components.

C. Accessories

Install approved accessories per instructions included with accessories. Contact your dealer for a list of approved accessories.

WARNING! Risk of Fire and Electric Shock! Use ONLY Hearth & Home Technologies-approved optional accessories with this appliance. Using non-listed accessories could result in a safety hazard and will void the warranty.

Remote Controls, Wall Controls and Wall

Switches

Follow the instructions supplied with the control installed to operate your fireplace:

For safety:

- Install a switch lock or a wall/remote control with child protection lockout feature.
- Keep remote controls out of reach of children.

See your dealer if you have questions.

Optional Fan

Follow the instructions supplied with the fan kit to operate your fan. See your dealer if you have questions.

Heatilator, a brand of Hearth & Home Technologies
7571 215th Street West, Lakeville, MN 55044
www.heatilator.com

Please contact your Heatilator dealer with any questions or concerns.
For the location of your nearest Heatilator dealer,
please visit www.heatilator.com.

Printed in U.S.A. - Copyright 2019